

Master's Thesis
석사 학위논문

Energy-Aware Access Point Management for Green WLAN

Rojeena Bajracharya (로지나 버저라찰여)

Department of Information and Communication Engineering
정보통신융합공학 전공

DGIST

2013

Master's Thesis
석사 학위논문

Energy-Aware Access Point Management for Green WLAN

Rojeena Bajracharya (로지나 버저라짚여)

Department of Information and Communication Engineering
정보통신융합공학 전공

DGIST

2013

Energy-Aware Access Point Management for Green WLAN

Advisor : Professor Kyung Joon Park
Co-advisor : Professor Hangsoo Choi

by

Rojeena Bajracharya
Department of Information and Communication
DGIST

A thesis submitted to the faculty of DGIST in partial fulfillment of the requirements for the degree of Master of Science in the Department of Information and Communication Engineering. The study was conducted in accordance with Code of Research Ethics¹

12.04.2013

Approved by

Professor Kyung Joon Park (Signature)
(Advisor)

Professor Hangsoo Choi (Signature)
(Co-Advisor)

¹ Declaration of Ethical Conduct in Research: I, as a graduate student of DGIST, hereby declare that I have not committed any acts that may damage the credibility of my research. These include, but are not limited to: falsification, thesis written by someone else, and distortion of research findings or plagiarism. I affirm that my thesis contains honest conclusions based on my own careful research under the guidance of my thesis advisor.

Energy-Aware Access Point Management for Green WLAN

Rojeena Bajracharya

Accepted in partial fulfillment of the requirements for the
degree of Master of Science.

12. 04. 2013

Head of Committee _____(인)
Prof. Kyung Joon Park
Committee Member _____(인)
Prof. Hangsoo Choi
Committee Member _____(인)
Prof. Jihwan Choi

MS/IC 로지나 버저라팔여. Rojeena Bajracharya. Energy-Aware Access Point
201222003 Management for Green WLAN. Department of Information and Communication
Engineering. 2013. 39P.
Advisors Prof. Kyung Joon Park, Co-Advisors Prof. Hangsoo Choi.

ABSTRACT

Over the past few decades, wireless communication has experienced phenomenal growth and has now become fundamental to daily activities. However, this unprecedented growth comes at a price: due to the always-on usage model, these standards are responsible for a large amount of energy consumption. Optimizing the energy consumption of access points (APs) has become a new challenge for the research community, governments and industries in order to reduce CO₂ emissions and operational energy costs. In this context, wireless local area networks (WLANs) that consist of a high-density of hundreds to thousands of APs are being deployed rapidly in corporate offices and universities to satisfy user demands for high bandwidth, mobility, and reliability. Moreover, these networked APs are provisioned for busy or rush hour loads, which typically exceed their average utilization by a wide margin. In addition, these margins are rarely reached and when reached, last only for a short period of time. Thousands of WLANs worldwide compound this problem, as they remain idle for long periods of time, raising serious concerns about energy losses. In response to this compelling problem, this thesis presents a set of contributions that address the challenge of increasing energy efficiency in Wi-Fi networks. In particular, we introduce novel energy efficient algorithms for dynamically powering off certain APs by exploiting the knowledge of the distance between the User Equipment's (UEs) and servicing APs while retaining the best user experiences. The network design was mainly evaluated based on the benefits of a centralized structure and the resulting turn off WLAN APs upshot in a network that provides adequate radio signal coverage and the required data rate capacity to serve user traffic demand in the service region. Our proposed algorithms are thoroughly evaluated by means of ns-2 simulations. The proposed solution achieves significant power reduction of the network up to 30 to 40 % compare with always on case without significant reduction of overall network throughput.

Keywords: Wireless Local Area Network (WLANS), Access Points (APs), Energy efficiency, Received signal strength indication (RSSI).

Contents

Abstract.....	i
List of contents.....	iii
List of tables.....	v
List of figures.....	vi
I. INTRODUCTION	1
II. RELATED WORK	3
III. BACKGROUND	6
3.1 WLAN Overview	6
3.1.1 Network Capacities and User Density	
3.1.2 Coverage	
3.1.3 Frequency Channel Assignment	
3.1.4 Structure of Service Areas	
3.1.5 Redundancy	
3.2 Principle of RSSI.....	11
3.2.1 Relationships between RSSI and distance	
IV. PROBLEM STATEMENT	14
4.1 High-density WLANs.....	14
4.2 Traffic Intensity.....	14
4.3 Case Studies.....	15
V. PROPOSED ALGORITHM	17
5.1 Network Architecture.....	17
5.2 Power Saving Scheme.	18
5.2.1 Power saving algorithm	
5.2.2 Implementation of switch-off scheme	
VI. SIMULATION	23
6.1 Simulation scenario.....	23
6.2 Performance Metric Used.....	24
6.3 Result and Analysis.....	24
VII. CONCLUSION	31

REFERENCES	32
ACKNOWLEDGMENT	36

List of tables

Table I: Simulation Parameters.....	23
Table II: Received RSSI power.....	25
Table III: Received RSSI power.....	28

List of figures

Figure 3.1: Infrastructure Mode.....	7
Figure 3.2: Non-Infrastructure Mode.....	7
Figure 3.3: Frequency spectrum allocations for IEEE 802.11b and 802.11g	11
Figure 3.4: Standard graph showing relationship between RSSI and [-log (distance)].....	13
Figure 4.1: Analysis of number of AP in range and traffic generation pattern.....	15
Figure 4.2: Analysis of daily and weekly traffic generation rate.....	16
Figure 5.1: Proposed Network Architecture	17
Figure 5.2: A flowchart of Switch OFF scheme.....	20
Figure 6.1: Aps deployment structure.....	24
Figure 6.2: Analysis of power consumption vs. data rates.....	26
Figure 6.3: Analysis of throughput vs. data rates.....	27
Figure 6.4: AP deployment structure.....	27
Figure 6.5: Analysis of power consumption vs. data rates.....	29
Figure 6.6: Analysis of throughput vs. data rates.....	30

I. INTRODUCTION

WLANs have become indispensable for flexible Internet connectivity in corporate offices, university, campuses, and municipal downtowns. A number of devices such as access points (APs), switches, and routers for providing and establishing Internet connections have also increased to accommodate the tremendous increase in internet users.

With increasing budgets, enterprises have now shifted their deployment objective from providing just basic complete coverage to designing dense WLANs with redundant layers of APs. These redundant APs are dimensioned to provide very high bandwidth in situations where hundreds of enterprise clients simultaneously run bandwidth-intensive and delay-sensitive applications. Although redundant capacity benefits enterprise users during times of peak demands, our recent studies show that peak demand rarely occurs [4]. In fact, only a small fraction of APs are utilized during the day, and even fewer during nights and weekends. The majority of the APs frequently remain idle, which means they serve no users in the network. Additionally, the existing design approaches lack several key elements. First of all, traffic demand and user density are not considered. The coverage-based optimization approaches may appear insufficient for networks where user density and traffic load is high. However, we argue that they will be insufficient in the future WLAN environments with higher user concentration and applications demanding increased data rates.

The goal of this dissertation is to develop a formal network design model and an efficient solution technique to the WLAN design problem to manage WLAN resources to save energy while ensuring scenario-specific end-user performance guarantees. We focus on access networks, since access devices are the main energy consumers in 802.11 WLANs. So, we propose a novel approach for the energy-aware management of access networks, consisting in a dynamic network planning, that, based on the instantaneous traffic intensity, reduces the

number of active access devices when they are underutilized (typically at night e.g. APs, switches and routers). Here the turning on/off decision parameter is dynamically set according to the distance value of client with respect to the access point and the distance value can be calculated by using a parameter of the Receiving Signal Strength Indicator (RSSI). As a result, WLAN coverage is still maintained; only redundant coverage is reduced. When user demand increases, WLAN resources are powered on to scale resource and coverage redundancy proportionately. In high-density WLANs, our proposed model strategies will thus reduce energy wastage without adversely impacting coverage and end-user performance.

Therefore, in this dissertation, a novel demand based WLAN design model has been developed and formulated which ensure coverage and maintain client performance. The presented network design for WLANs identifies a sufficient number of APs and determines an efficient combination of the network parameters. The framework of the developed demand-based WLAN design methodology is flexible and applicable to various network service environments, ranging from those with small, single floor service areas to those that are complex with multiple-floor service areas and those with a combination of indoor and outdoor service areas.

II. RELATED WORK

Previous work in the field of WLANs relative to reducing power consumption efficiently has been done at various levels, to core [7], edge [8], mobile [10] and data-center networks [9] including construction of the algorithm, design of the infrastructure, etc. Reducing power consumption can be achieved on a larger scale by introducing intelligence into the network infrastructure at various levels by employing different kinds of algorithms. In this paper we have proposed an energy-efficient research and development policy for corporate WLANs, in which the dense distribution of APs is exploited to power off unused devices. Several recent works [11, 12] proposed approaches to reduce the energy consumption in WLANs, but they mainly focused on the user side, in order to preserve battery lifetime. These approaches can be easily integrated with energy-aware policies that efficiently control the AP power consumption.

Looking at the internal architecture of the APs normally deployed in WLANs, researchers have observed that the largest amount of power consumption is due to base components, rather than transmission circuits, so that an AP consumes approximately the same amount of power, independently from the traffic that is flowing through it [13]. This confirms that powering off unused APs can be a viable solution to save energy.

Jardosh et al. [4] [18] suggest the adoption of resource on-demand strategies for centrally managed WLANs without adversely impacting the performance of clients in the network. The most important message of this paper is that the energy wasted in large-scale and high-density WLANs is a new and serious concern, which can be reduced through on-demand powering off APs, named SEAR algorithm. An analytical model for assessment of the effectiveness of (Research and Development) RoD strategy introduced in [4] has been proposed by authors in [18]. The proposed model is used for studying two simple on-demand policies (volume and location of user demand), which is based on instantaneous WLAN

parameters, selecting the appropriate number of APs to activate, thus trying to avoid to energy waste on underutilized APs. The obtained results showed that SEAR can reduce power consumption up to 46%.

L. Chiaraviglio & Ajmone Marsan et al. [19] [20] investigated energy-aware dynamic planning in the context of Universal Mobile Telecommunication System (UMTS) access networks; the main idea is to switch off some access devices during low traffic periods (such as nights), the devices that remain on being in charge of the whole traffic [10]. The assumption is that some cells in the access network can be switched off when traffic is low. This implies radio coverage and service provisioning can be taken care of by the cells that remain active, which requires small increase in the emitted power that increases the cell size and some adjustments in other network parameters, such as antenna tilting. Still, some switch-off patterns may not be feasible, due to specific site positions that require some cells to be always on, to provide full coverage.

The research in thesis [22] proposed simple design algorithm for maximum efficiency in terms of power and cost while retaining the best user experience. Designs were mainly evaluated based on the benefits of a centralized structure and a non-centralized structure. A new algorithm was designed with a convex hull approach and was also implemented in the emulator kind of network test bed generating 60% savings in power consumption and costs. The another thesis [23], proposed a demand-based WLAN design model, formulated as a constraint satisfaction problem (CSP), results in a network that provides adequate radio signal coverage and the required data rate capacity to serve expected user traffic demand in the service region. An efficient heuristic solution technique was used to solve the CSP network design problem in reasonable computational time. The solution provides the number of access points required and the parameters of each access point, including location, frequency channel, and power level.

A mixed mode, which is the combined result of the infrastructure mode and the ad-hoc mode [21], was introduced to maximize efficiency and minimize burden on the network. Under a common access point, users would be capable of switching between the ad-hoc mode and the infrastructure mode, depending on the traffic conditions in a cell. This switching of modes [21] would be transparent to users, beneficial in terms of network resources, and have the following strengths: better utilization of the network bandwidth depending on the type of communication, i.e., whether an intra-cell communication or exclusive Internet traffic; and greatly improved throughput of the network, since traffic would be divided evenly according to the requirements.

As reported in [14], introducing power-off mechanisms in APs could save millions of dollars worldwide, or, equivalently, many tons of CO₂. Finally, renewable sources can be easily adopted to supply energy for APs. This idea has been investigated by researchers [15, 16], and commercial solutions using photovoltaic systems already existed [17]. Our approach can be of benefit also in this case, by limiting the amount of power needed during low traffic periods, especially at night, when the energy of the sun cannot be exploited.

III. BACKGROUND

3.1 WLAN Overview

In the history of communication, the development of radio-based LAN components was made possible in 1985 when the Federal Communications Commission (FCC) authorized the public use of the Industrial, Scientific and Medical (ISM) bands between 902 MHz and 5.85 GHz. People began developing radios and APs without a standard [1]. And in the late 1980s, the IEEE 802 working group developed the Wireless LAN (Local Area Network) Medium Access Control and Physical Layer specifications. The standard was published in 1997 and has been recognized as an important role in the access networks at the border of the Internet, designed originally for cable replacement in corporate environments. WLANs have become very popular in providing IP connectivity in residential, small office and campus environments. Innovations in this area are adapted at tremendous speed and worldwide use of Wi-Fi has soared in recent years. WLANs network configuration constitutes an AP and several wireless stations (WSTAs). APs, normally routers, are base stations that provide connectivity with the wired part of a network, thus allowing Internet services to be extended to wireless enabled devices. The basic service set (BSS) is a set of all stations (AP and WSTAs) that can communicate with each other. Every BSS has an identification (ID) called the BSSID, which is the MAC address of the access point servicing the BSS. A set of connected BSS constitute an Extended Service Set (ESS) where the access points are connected by a distribution system where stations within an ESS may communicate and mobile stations may move from one BSS to another (within the same ESS). Each ESS has an ID called the SSID, which is a 32-byte (maximum) character string. The 802.11 standard define two operating modes in a wireless network: Ad-Hoc mode and infrastructure mode. While the infra structure mode sets up devices to communicate through an access point, the Ad-Hoc mode works with a direct communication between them.

Infrastructure mode: In "infrastructure" mode, wireless devices communicate to a wired LAN via base stations known as "access points." Each base station connects a mobile device to a wired network. A process called "handoff" switches mobile devices between base stations providing connection to a wired network.

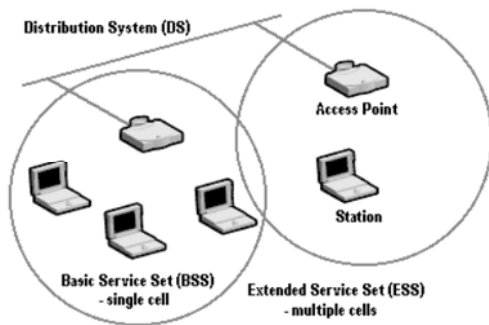

Figure 3.1: Infrastructure Mode

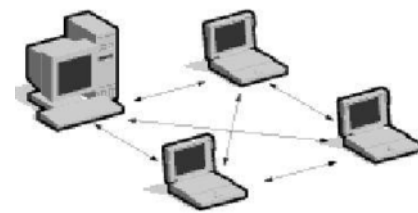

Figure 3.2: Non-Infrastructure Mode

Non-infrastructure mode: In "ad hoc" mode, also known as "peer-to-peer" mode, a base station is absent and nodes can only transmit to other nodes within link coverage. Here, nodes organize themselves into a network: route among themselves. [1]

An additional mode was added in 2009 that enables two devices to communicate with each other directly by Wi-Fi Direct.

The popularity and rapid widespread use of wireless networks is undeniable and observable.

The following play an important role in the popularity of wireless networks:

- Flexibility: Internet users are able to connect almost anywhere in the network with complete ease and comfort. Users are able to access all resources, such as servers, printers, and other systems, regardless of their location within wireless reach.
- Management: Much effort is required in managing wired networks, but managing wireless networks is easy.
- Minimal hardware: Wired networks must use many interim devices for connecting all users to the network. With wireless networks, hardware installations and costs have been minimized to a great extent.

While designing a wireless local area network, it is important to ensure that its users and performance are not impacted. In order to avoid such an impact and to maintain the critical requirement of energy savings, a list of design requirements to be implemented when designing and deploying wireless networks follows:

3.1.1 Network Capacities and User Density

Wireless terminals in a BSS rely on a common (broadcast) transmission medium. Only one terminal can occupy the medium at a time. If multiple terminals simultaneously transmit, a collision may occur and the signal could be corrupted. The IEEE 802.11 standard specifies a medium access control (MAC) protocol, called carrier sense multiple access/ collision avoidance (CSMA/CA), to coordinate wireless terminal transmission in the BSS. This coordination is achieved by means of control information. This information is carried explicitly by control messages traveling in the medium (i.e. ACK messages) and can be provided implicitly by the medium itself through the use of a carrier-sensing mechanism before each transmission to check if the channel is either active or idle. Control messages and message retransmission due to collisions consumes medium bandwidth. The overhead required by a MAC protocol coordinates wireless terminal transmissions. Although the 802.11b standard specifies that the AP can support channel data rates of 11 Mbps, BSS's actual capacity, defined as the fraction of channel bandwidth used by successfully transmitted messages, is less than 11 Mbps [5]. The practical throughput capacity decreases as the number of users (wireless terminals) associating with a particular AP increases [5].

Providing sufficient data rate capacity is the first step towards any type of quality of service (QoS) support. Many data services (e.g. IP telephony, video conferencing, and multimedia applications) require that networks provide a specified average data rate. In addition to adequate signal strength, these applications require a guarantee of access channel capacity. Since each AP can provide only a limited data rate capacity and its throughput reduces as the

number of users associated to it increases, a sufficient number of APs must be provided to support all traffic demand. However, one cannot over-deploy APs due to the limitation of frequency channels and interference problems among co-channel APs.

3.1.2 Coverage

A Basic Service Area (BSA) is the service coverage area of an AP. It is an area within which the received signal strength and the signal to interference ratio (SIR) level are sufficient to allow data communication between an AP and wireless terminals to take place. The size of a BSA varies with the AP's power level and the radio propagation environment [6] but wireless network performance depends on signal power. But in reality, the critical factor in measuring the overall performance of any communication system is signal-to-noise ratio (SNR)—the ratio of the signal power (S) to the noise power (N). The received signal strength at a particular location can be predicted using path loss models. In these models, the received signal level is estimated as a function of the distance and the radio propagation environment between an AP and a receiver [6].

3.1.3 Frequency Channel Assignment

Currently, two unlicensed frequency spectrum bands are available for use in IEEE 802.11 WLANs: 1) 2.4 GHz Industrial, Scientific, and Medical (ISM) band, and 2) 5 GHz Unlicensed National Information Infrastructure (UNII) band. While the legacy IEEE 802.11 and enhanced IEEE 802.11b/g WLANs operate on the 2.4-GHz band, the IEEE 802.11a WLANs employ the 5-GHz band. Both bands are available internationally. The number of allowable channels however varies from country to country due to each country's regulations on radio spectrum allocation. The 802.11 standard divides the 2.4 GHz band into eleven channels with center frequencies located 5 MHz apart as shown in Figure 1.2. Each channel has a frequency bandwidth of 22 MHz. Among these eleven channels are three channels whose bandwidths do not overlap each other. Those channels are 1, 6 and 11, as there is a frequency space of 3

MHz between channels 1 and 6 as well as between channels 6 and 11. These three channels are called the non-overlapping channels, and they can be assigned to adjacent APs without interfering with each other. The remaining channels overlap with one of the three non-overlapping channels and are called the overlapping channels.

Since a limited number of channels exist in the available frequency spectrum for an 802.11 WLAN, a large network deployment requires that all channels are used and some channels are reused. Reuse of frequency channels in neighboring BSAs can cause interferences in the service area. Thus, frequency channels of APs must be carefully assigned in large WLANs.

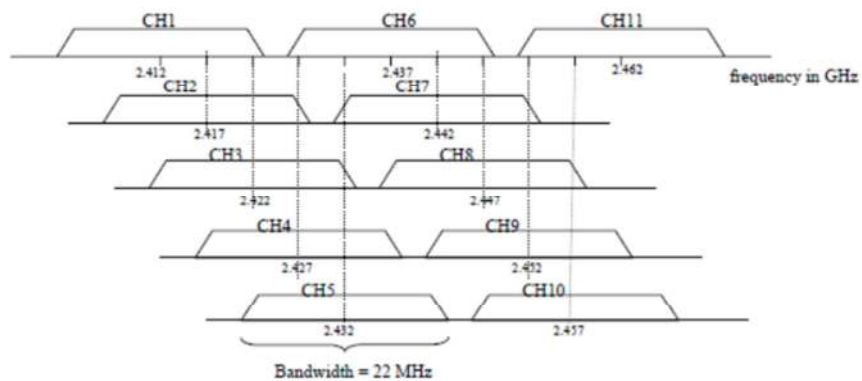

Figure 3.3: Frequency spectrum allocations for IEEE 802.11b and 802.11g

3.1.4 Structure of Service Areas

Different service area environments pose particular problems for WLAN planning due to differences in building material and architecture [6]. In offices and classrooms, radio coverage can be difficult to achieve due to the high density of walls. In library study areas, large auditoriums and lecture halls, the service areas are rather open and there are fewer walls. In a multi-floor building, signals from adjacent floors complicate the WLAN design problem. When designing all types of networks, AP placement and frequency assignment must be properly designed considering differences in the physical structures of the service areas.

3.1.5 Redundancy

In the design of a network, designers recommend the availability of redundant access points for extra coverage. Reasons for this can be anything related to heavy traffic loads or when a device suddenly stops functioning. Redundancy depends on the specific type of organization and other requirements related to it. A centralized structure ensures creativity and maintains all the functionality of APs, while providing redundancy and efficiency simultaneously to all users in the network. A centralized structure will also help in calculating the number of access points to be deployed as redundant.

3.2 Principal of RSSI

Received signal strength indicator (RSSI) is a measurement of the power present in a received radio signal [26]. RSSI is a generic radio receiver technology metric, which is usually invisible to the user of the device containing the receiver, but is directly known to users of wireless networking of the IEEE 802.11 protocol family. The principal of RSSI describes the relationship between transmitted power and received power of a wireless signal and the distance among nodes. This relationship is shown by equation (1) [24].

$$Pr = Pt * (1/d)^n \dots\dots\dots (1)$$

where, Pr is receiving power, Pt is the transmitted power; d is the distance between sender and receiver node and n is the transmission factor whose value depends on the propagation environment. Take 10 times the logarithm of both sides of (1), and then Equation (1) is transformed to Equation (2).

$$10 * \log Pr = 10 * \log Pt - 10n * \log d \dots\dots\dots (2)$$

where, Pt the transmitted power of nodes, is given. $10 \log P$ is the expression of the power converted to dBm. Equation (2) can be directly written as Equation (3).

$$Pr(dBm) = A - 10 * \log d \dots\dots\dots (3)$$

A , is received power from references distance which is 1 meter. By Equation (3), we can see

that the values of parameter A and parameter n determine the relationship between the strength of received signals and the distance of signal transmission.

Thus, network planning of WLANs must determine the appropriate power levels of APs in order to provide specified signal strength while maintaining sufficiently low levels of interference in the service area.

3.2.1 Relationships between RSSI and distance

As we have discussed about the principle of RSSI previously. RSSI is defined as ten times the logarithm of the ratio of power of the received signal and a reference power [25].

$$\text{i.e. } \text{RSSI} \propto 10 \log Pr/Pref$$

This would mean that $\text{RSSI} \propto \log Pr$. It is known that power dissipates from a point source as it moves further out and the relationship between power and distance is that power is inversely proportional to the square of the distance travelled. In other words,

$$\text{RSSI} \propto \log (1/\text{distance}^2)$$

Simplifying this relationship further we can conclude that $\text{RSSI} \propto (-\log \text{distance})$.

Thus, if we were to plot the RSSI measured and plot it against a log of distance we should be able to obtain an inverse linear relationship and a graph thus generated would serve as a standard curve that can then be employed by a receiving node to estimate the distance at which a sending node would be located. To put this mathematically, consider the standard graph given in Figure 3.4.

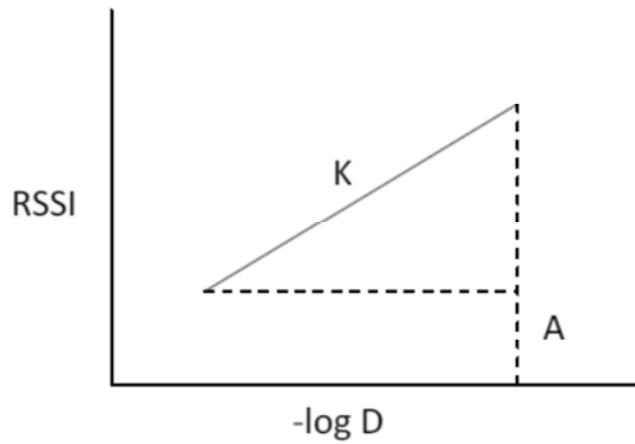

Figure 3.4: Standard graph showing expected relationship between RSSI and [-log(distance)]

K is the slope of the standard plot. K can be obtained by performing a linear regression analysis on the data points used to generate the standard curve. This analysis could also provide the estimate of the constant parameter 'A' in the equation that fits the data the best. Further this linear regression fit plot can be used to estimate the distance between two nodes for a given RSSI value based on the formula as shown below

$$RSSI = -K \log D + A$$

IV. PROBLEM STATEMENT

During the last decade, the energy consumption of the information and communication technologies (ICTs) sector has become a key issue, from both economic and environmental perspectives. ICT alone is responsible for a percentage, which varies between 2% and 10% of the world's power consumption [1]. The Global e-Sustainability Initiative (GeSI) [2] estimates an overall network energy requirement of about 21.4 TWh in 2010 for European Telcos, and foresees a figure of 35.8 TWh in 2020 without Green Network Technologies (GNTs). Furthermore, the number of enterprise deployments and the average number of APs in each enterprise WLAN is increasing exponentially every year. Although the energy consumption of the Base Station (BS) is much higher compared to the AP, the vast number of WLAN network devices installed worldwide contributes to the enlargement of the energy consumption in wireless access networks.

4.1 High-density WLANs

With increasing budgets, enterprises have now shifted their deployment objective from providing just basic complete coverage to designing dense WLANs with redundant layers of APs. These redundant APs are dimensioned to provide very high bandwidth in situations where hundreds of enterprise clients simultaneously run bandwidth-intensive and delay-sensitive applications. The number of redundant layers of APs varies based on the usage characteristics, design policies, and budget restrictions of the enterprise. One example of such an enterprise WLAN is installed at Intel Corporation's buildings in Portland, Oregon, where 125 APs have been deployed at distances of about five meters from each other within a single four-floor building. Another example is the Microsoft campus at Redmond, WA, which will soon have a 5000-AP centralized WLAN [4].

4.2 Traffic Intensity

If we look at usage patterns of APs and consider the number of users and the number of

traffic bytes sent and received between each user and the AP in each WLAN, this shows that traffic loads follow a periodic day/night traffic pattern as shown in Figure 4.1. This reduction of the traffic in cellular network is due to the combination of two effects: i) the typical day and night behavior of the users; ii) the daily swarming of the users carrying their mobile terminals from residential areas to office districts and back, resulting in the need for large capacity in both areas at peak usage times, but reduced requirements during the period in which the area is lightly populated (day for residential areas and night for office areas). Moreover, when an analysis of available network capacity utilization was done, it was discovered that most Wi-Fi networks are significantly underutilized [27] [28]. The medium utilization is less than 40% in all settings, even during the busiest times, and much lower during other times. This means that peak usage times are rare and sometimes even isolated to a specific portion of the WLAN. As a result, the energy cost of maintaining the hundreds to thousands of always-on idle APs and wired backhaul switches is significant.

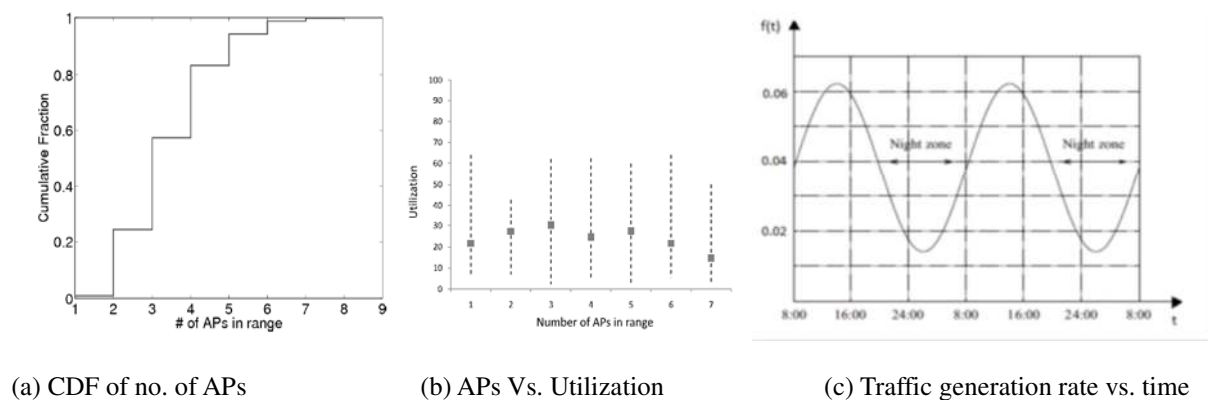

Figure 4.1: Analysis of number of AP in range and traffic generation pattern.

4.3 Case Studies

Figure 4.2 shows the traffic generation of an enterprise network United Nation Regional Office of South Asia (UN ROSA) on a daily and weekly basis where 30 APs deployed to support approximately 100 clients. The figure clearly shows that a large fraction of APs are idle for many hour per day and over an entire week, the fraction is much larger as we can see

negligible traffic during nights and weekends. We believe that these results are representative of several other WLAN deployments as well. These results show that WLAN capacity is frequently underutilized. Idle APs in WLANs across the globe directly equate to an enormous waste of energy that is used to keep the idle APs powered on. Based on these observations, we conclude that WLANs must be redesigned with energy-efficiency as a critical design constraint. Such an energy-efficient WLAN infrastructure should appropriately power on and off WLAN equipment so that they stand to save both critical energy, as well as monetary resources.

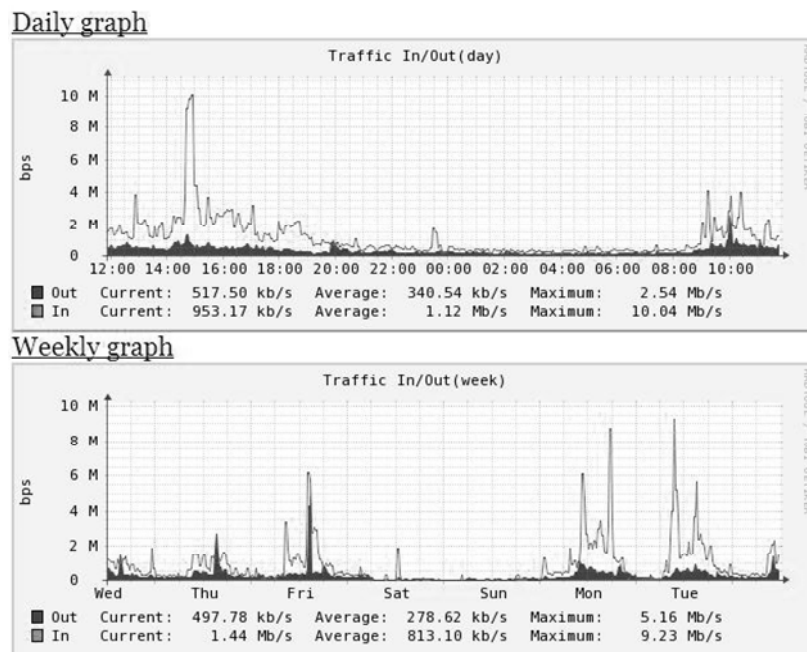

Figure 4.2: Analysis of daily and weekly traffic generation rate.

V. PROPOSED ALGORITHM

This section explains a proposed algorithm that could be run in a centralized structure and that adheres to the design requirements. The objective of this algorithm is to simply explore the magnitude of energy savings that can be achieved in its adoption and how it works in a centralization structure. This algorithm does accomplish the objective, and later on, details of how the algorithm is implemented in the prototype are explained.

5.1 Network Architecture

We consider a dense deployed network, where the coverage areas of neighboring cells overlap each other. Our network consists of a set of X cells that have the same coverage radius R and traffic load that has the periodic day/night pattern Figure 4.3(c).

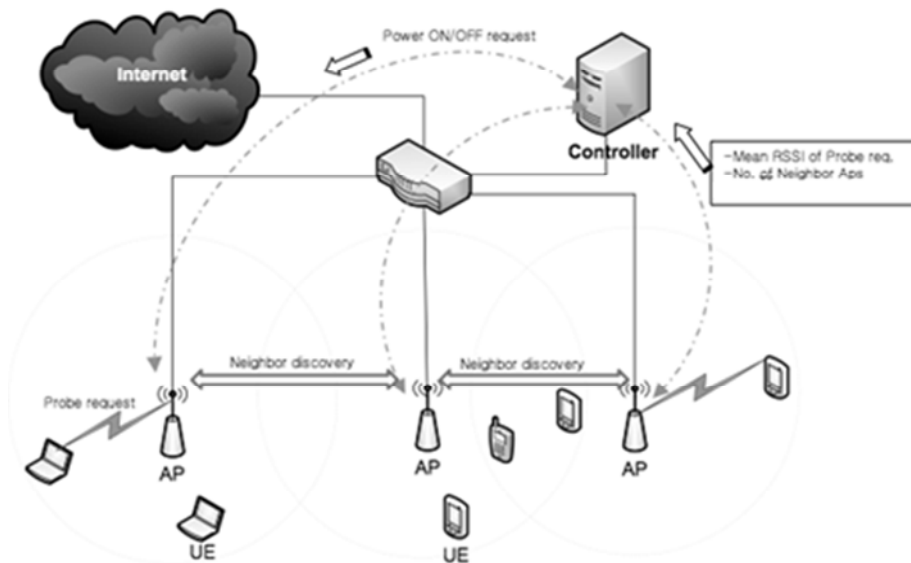

Figure 5.1: Proposed Network Architecture

Figure 5.1 shows the architecture of the wireless access network on which the proposed scheme is employed. The network administrator places a controller on the network. The controller receives information from each AP such as mean received signal strength indicator (RSSI) of probe request from User Equipment's (UE), list of neighbor APs, and the number of connected UEs. By using the information, the controller determines whether each AP

should be power-on or power-off. The power-on APs and the power-off APs are defined as active APs and sleeping APs respectively. Finally the controller transmits power-on or power-off requests to each AP.

5.2 Power Saving Schemes

We present power saving schemes, which turn off the redundant APs during low traffic load. The proposed idea is to switch off APs not according to traffic load, but according to the average distance of its users. Therefore, each AP should estimate the distance of its UEs as well as UEs of neighboring APs up to the coverage region. Each AP calculates the average of the above distances. Greater average distance leads to greater average transmission power. Our algorithm proposes to switch off the APs with the maximum average distance value because these APs would increase their APs transmission power to a greater value if, they were switched on.

5.2.1 Power saving algorithm

The proposed APs switch off algorithm works as follows:

Step 1: The first step is Neighborhood discovery where we determine whether two APs that belong to the same WLAN can be neighbor of each other. Two APs in a WLAN can be neighbor if they are in close physical proximity of each other. In this technique, every AP will transmit beacon message in regular interval of time and neighboring APs use to hear and update its Neighbor table after receiving n beacons and remove from the table after m missed beacons.

Step 2: At the second step, UEs sends a Probe Request to all channels in order to localize the AP. Each AP estimates the RSSI value of the probe request from UEs from its own clients as well from neighboring APs and this information is stored in the AP for statistical purpose.

Step 3: The APs calculate the average distance of the traffic load based on the results of the

second step. The APs are ranked based on the estimated average and they are examined from the top one with the maximum average distance value which is less average RSSI probe power.

Step 4: The first AP is switched off if it exceeds threshold number (depends on network size) of the neighboring APs in its neighboring table and the number of connected user.

Step 5: The algorithm continues with the next APs in the list, until less than equals to the half of APs is switched off. As the APs are switched off, we should guarantee that there is no QoS degradation.

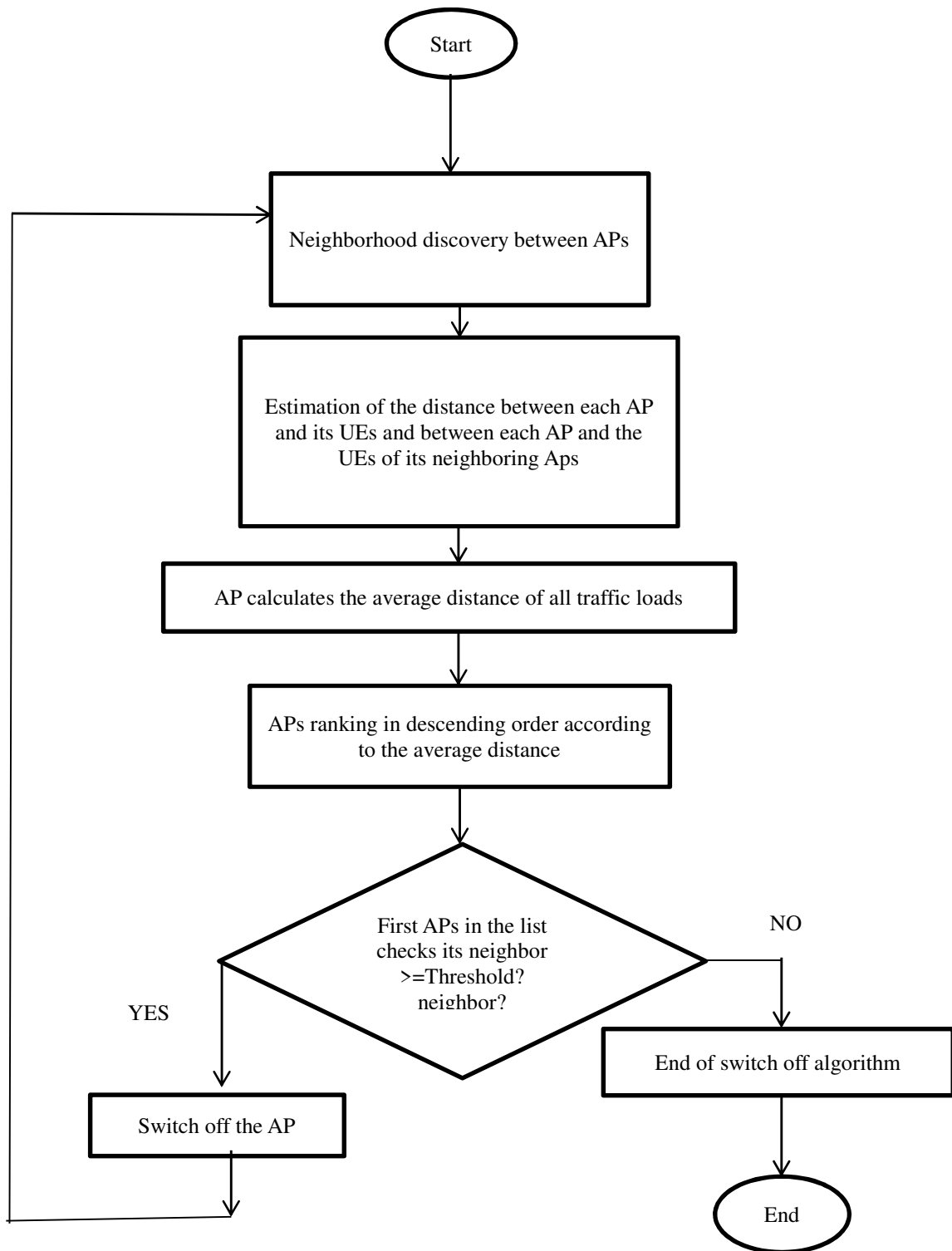

Figure 5.2: A flowchart of Switch OFF scheme

5.2.2 Implementation of switch-off scheme

Once the APs to be switched off have been identified, the question arises about how to implement switch-off. Of course, it is not possible to just switch off the APs, since, even if the traffic is low, a number of users may be accessing the candidate AP with their terminals for voice, video or data services.

In [20], the authors consider three different possibilities.

1. After the switch-off decision is taken, the network waits until no user is accessing the candidate AP, which is thus switched off only when idle. This is the least invasive approach for users, but an obvious drawback is that the time between the switch-off decision and the AP idling may be long, thus limiting the effectiveness of the energy saving approach.

2. As soon as the switch-off decision is taken, no new service requests are accepted by the candidate AP, which can be switched off as soon as all services in progress at the time of the switch-off decision terminate i.e. that some service requests will be blocked. The delay between the switch-off decision and the actual switch-off is less than in the previous case, but still significant, coinciding with the longest residual time of the services in progress at the time of the decision.

3. Immediately after the switch-off decision is taken, users are forced to implement a handover from the AP that is going to be switched off to one of the APs that remain active. This is the most invasive approach for users, but forced handovers are foreseen by WLAN standards, and thus the algorithm is well within the possibilities of present WLANs equipment. Actually, forced handovers are already used by many operators, called as Blacklisting, where access control black lists to enforce a client handoff between APs. One of the examples of this technology used is the MadWifi Atheros chipset wireless driver, which allows an AP to use such black lists of MAC addresses of clients [4]. If the MAC address of a client is present in that list, the AP will not allow the client to associate with it. The advantage

of using black-lists on APs is that the clients are forced to associate with only those APs on which they are not black-listed. As a client is moved from a one AP to another AP, the client is added to the first AP's black-list. This forces the client to disconnect from the first AP and associate with the new AP. The important advantage of this approach lies in the fact that the time between the switch-off decision and the actual switch-off can be controlled by the operator, and kept very low, so as to maximize the energy reduction effect.

VI. SIMULATION

6.1. Simulation scenario

In this work, we use Ns2.35 as a network simulator. Here we will be testing our algorithm for different scenarios with varying numbers of access points. In each iteration of the simulation, UEs are placed in the system area based on a uniform distribution and the APs generate traffic according to a Poisson distribution. The packet size we use for the simulation is 100kb and a rate varies from 5kbps

Table I
Simulation Parameters

<i>Traffic Model</i>	
<i>Model</i>	<i>Poisson</i>
<i>Packet Size</i>	<i>100 bytes</i>
<i>Rate</i>	<i>5-1000kbps</i>
<i>Radio Network Model</i>	
<i>Propagation Model</i>	<i>TwoRayGround</i>
<i>Coverage</i>	<i>250m</i>
<i>Area</i>	<i>1000X500m 1000X1000m</i>
<i>Energy Model</i>	
<i>Rx Power(watts)</i>	<i>0.5</i>
<i>Tx Power(watts)</i>	<i>0.75</i>
<i>Sleep power(watts)</i>	<i>0.002</i>
<i>Node Model</i>	
<i>Time (sec)</i>	<i>30</i>

to 1000kbps. The simulation was observed for 30 sec. In this case, we use Tworayground propagation model as a propagation radio model and we vary Pt and RxThresh to adjust the coverage area of the network. For the calculation of the power consumption, we consider the power that is consumed in the APs for the downlink transmission. Models and simulation assumptions are selected according to the 802.11 evaluation criteria (summarized in Table D). For neighborhood discovery, we deployed APs to transmit a beacon signal every 0.02 sec so that neighborhood APs can detect the signal and add it to the neighborhood APs table for further processing. Here, we apply the active scanning process where the entire client starts scanning the channel which is done through sending multiple probe requests and recording the probe responses (containing BSSID and WLAN SSID). Dump agent has been used as a routing protocol to direct all the packets through the AP. Three different network conditions have been tested for exactly same traffic pattern and node positions. The first experiment was tested with all APs On with full power. In the second case, we randomly turn off the APs. In the third case, APs radio is turned off on the basis of the purposed algorithm and power

consumption and throughput was measured for different traffic generation rates.

6.2 Performance Metric Used:

The following two metrics have been chosen for performance analysis of the networks:

6.2.1 Power Consumption: The total power consumption required to transmit, receive and process of the signal by the node.

6.2.2 Throughput: The number of packets successfully transmitted to their final destination per unit time. The ratios between the numbers of send packets vs. receive packets.

6.3 Result and Analysis:

6.3.1 Scenario 1: The first scenario checks the infrastructure mode operation in a simple topology composed of 3 APs and 4 UEs in 1000X500m area. While node 0, 1 and 2 are Aps, nodes 3, 4, 5 and 6 represent 4 UEs as shown in Figure 6.1.

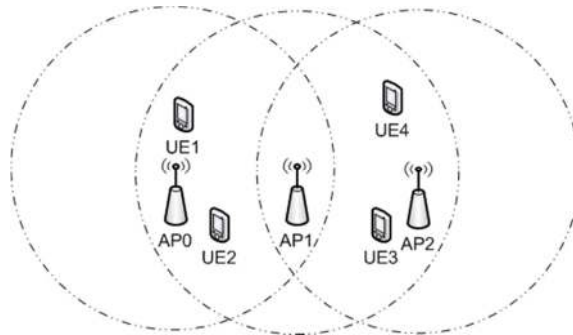

Figure 6.1: APs deployment structure.

When we apply the random switch on/off scheme, we assume that AP0 is switched off based on a random decision. However, according to our proposed algorithm, we choose to switch off AP1, since the UEs are gathered near the cell edge far from AP1 according to the result from the RSSI power calculation as shown Table II.

Figure 6.2 (a) shows the average power consumption of our proposed scheme compared to the random algorithm and the case that all APs remain active. Figure 6.3 (b) represents the maximized view of random and proposed algorithms.

From an analysis of the data, we can say that by using a distance aware switch off mechanism, we can reduce the energy consumption of the whole network for the same amount of traffic generation. We assume that all APs can be switched off for about 12 hours, saving 31% of power consumption during the night: compared to the random switch on/off algorithm, our proposed scheme achieves up to 1.44 % more efficiency.

Table II
Received RSSI power

APs	Power(db)
0	7691.13
1	89.18
2	3845.57

Figure 6.3 shows the average UDP throughput achieved by the network for various data rates with three different experiment scenarios. We observed that when our proposed method is used, the average throughput received by clients was 3.1% less than the throughput received in the always-on case. This small drop in average throughput occurs because some of the APs are powered off and the clients associate with an AP that does not provide them with the highest throughput. Fortunately, the drop in throughput is not too high. We believe that WLANs with a higher density of APs and/or stricter neighborhood AP conditions are likely to have an even smaller impact on client performance. It clearly illustrates that although 40% of APs have been switching off the whole network throughput sees only an unremarkable change.

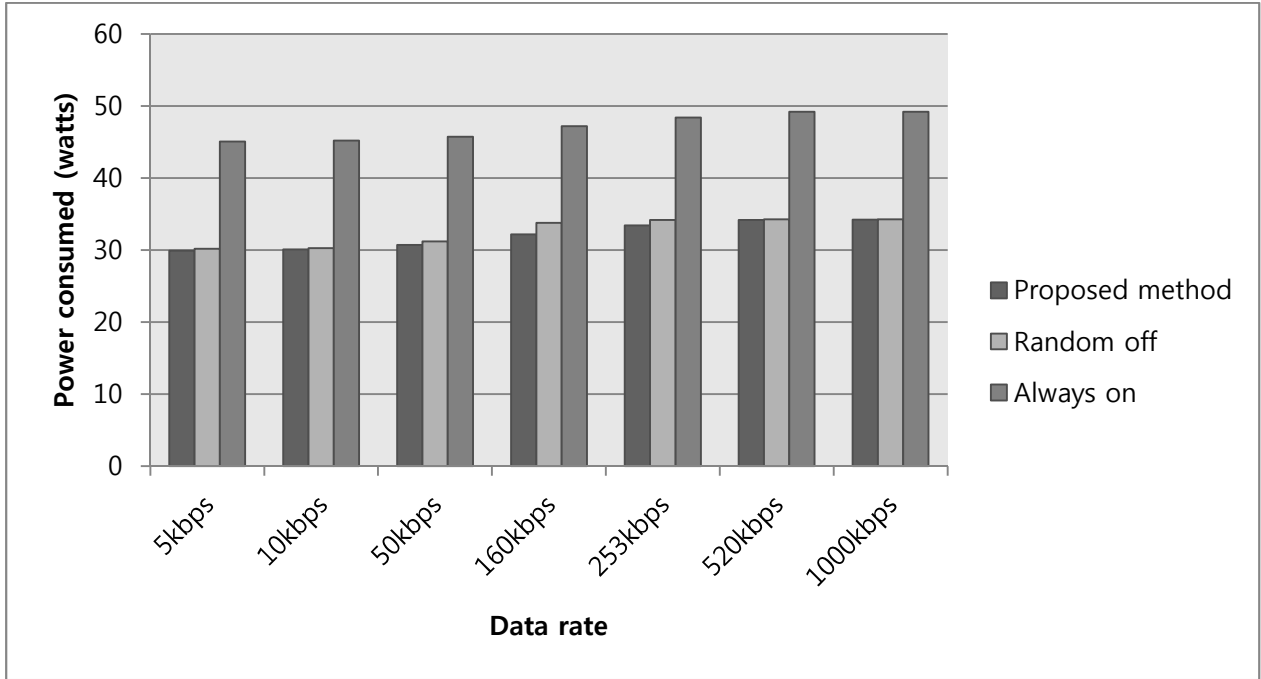

(a) Average power consumption

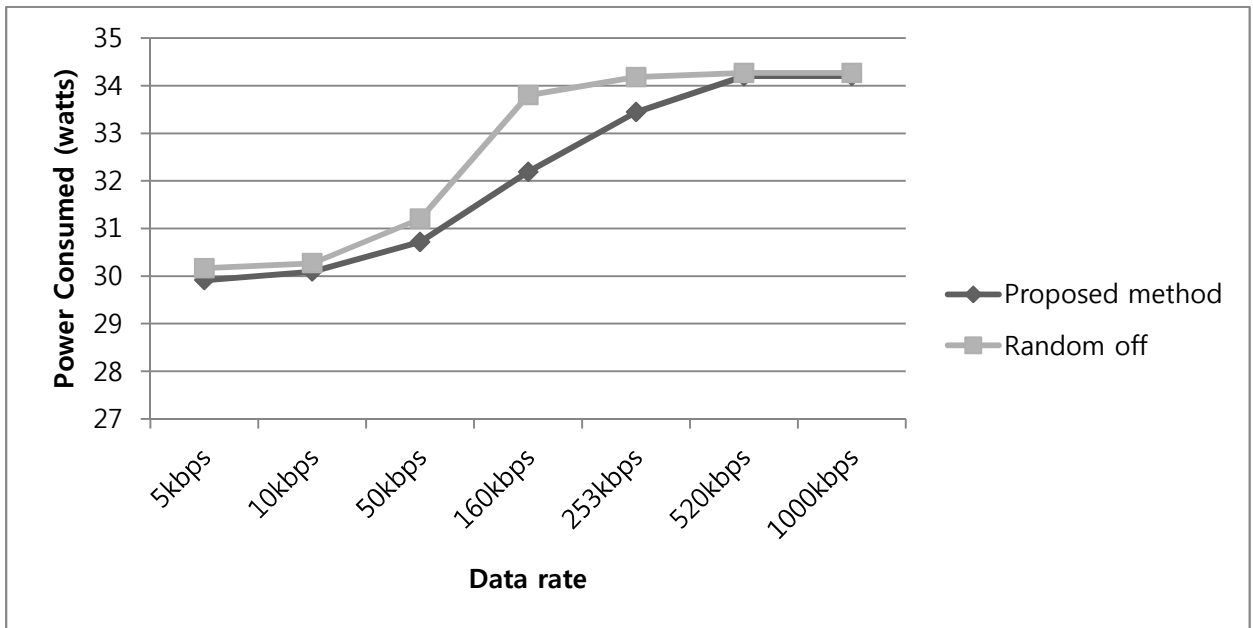

(b) Maximize view of random and proposed method

Figure 6.2: Analysis of power consumption vs. data rates.

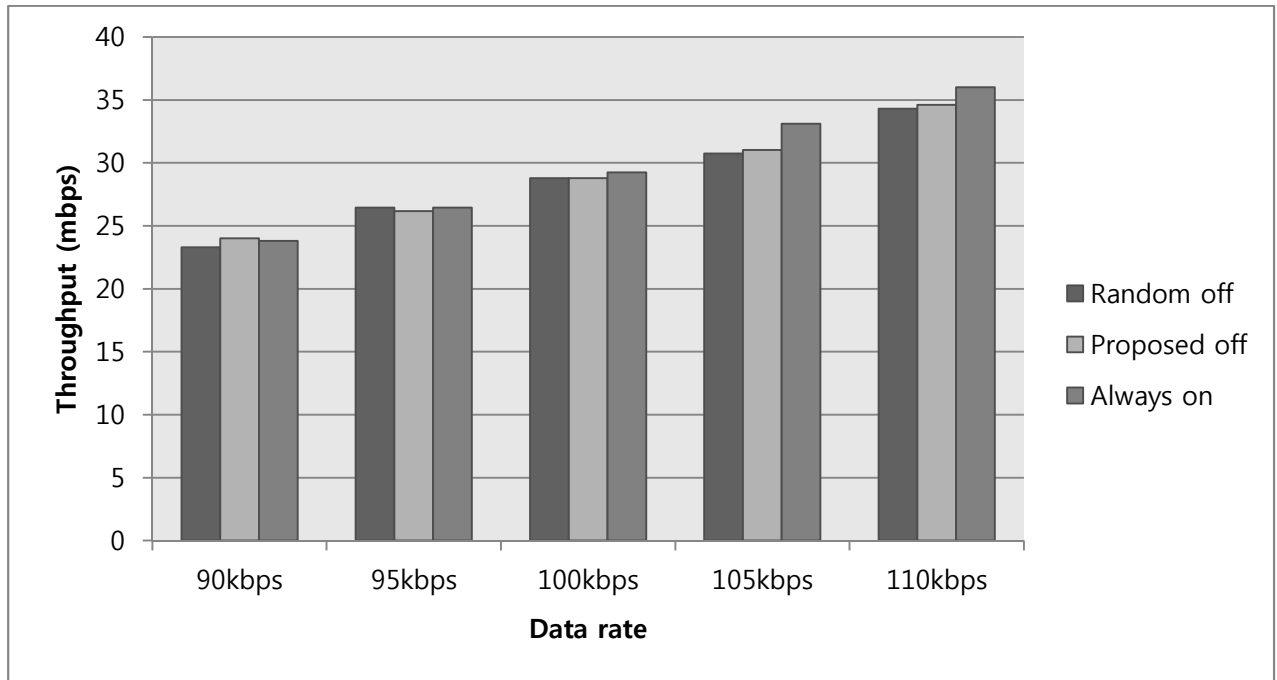

Figure 6.3: Analysis of throughput vs. data rates.

6.3.2 Scenario 2: The second scenario was checked with a grid topology composed of 9 APs with 10 UEs in 1000X1000m area. While nodes 0 to 8 represent APs, nodes 9 to 18 represent 10 UEs in the random position (see Figure 6.4).

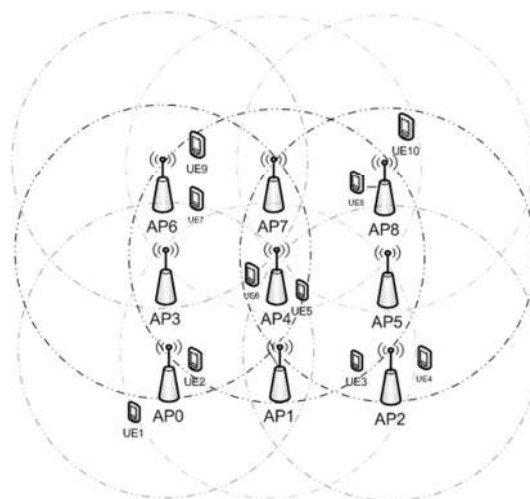

Figure 6.4: AP deployment structure

Similarly, when we apply the random switch on/off scheme, we assume that AP0, AP3, AP4, and AP8 are switched off based on a random decision. However, according to our proposed algorithm, we select to switch off AP1, AP3, AP5, and AP7 according to the result of the

RSSI power calculation as shown in Table III.

From an analysis of the data, we can say that by using a distance aware switch off mechanism, we can reduce the energy consumption of the whole network by 40 % (see Figure 6.5) of energy saving by turning off less than half of the network; and over a random switch-off, our proposed scheme has a higher percentage of energy savings. In addition, we achieved a very small drop in average throughput, even in

networks smaller than 3AP. The drop in throughput was just 2%, (see Figure 6.6) which is very good for client performance. For comparison, with the random random-off case scheme, we can see that the saw network throughput degrade by 12.47%.

Table III

Received RSSI power

APs	Power(db)
0	7691.13
1	89.17
2	6356.3
3	89.16
4	7691.13
5	89.17
6	8593.17
7	89.18
8	6356.3

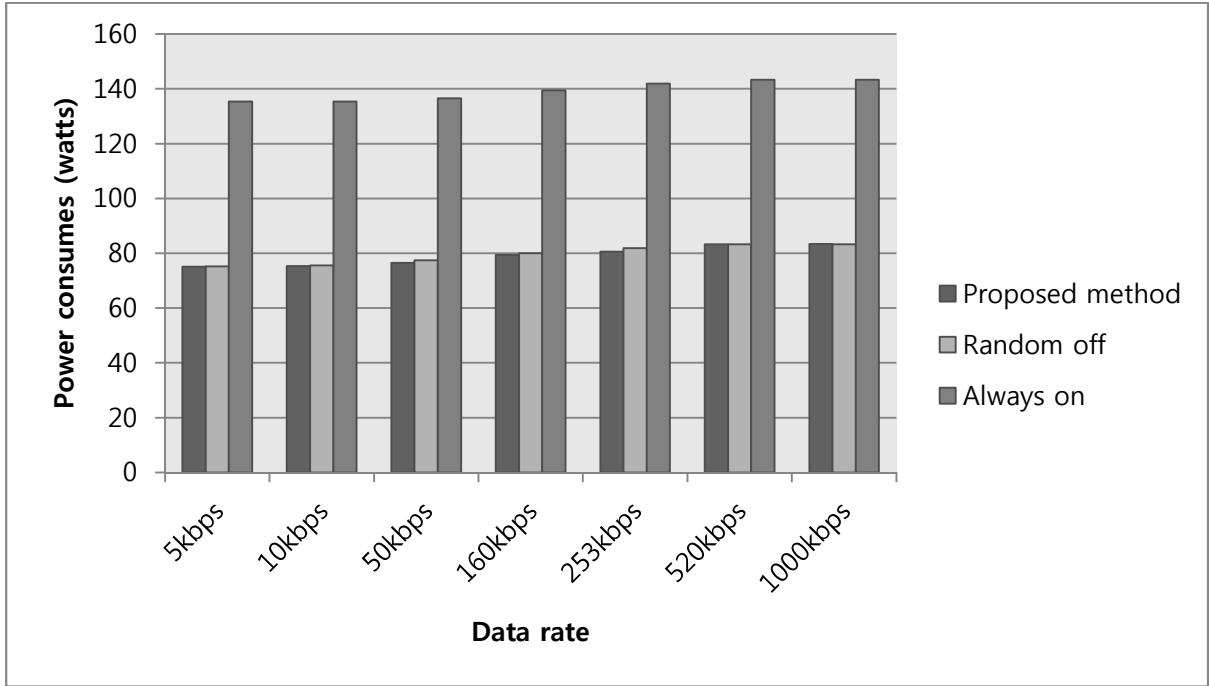

(a) Average power consumption

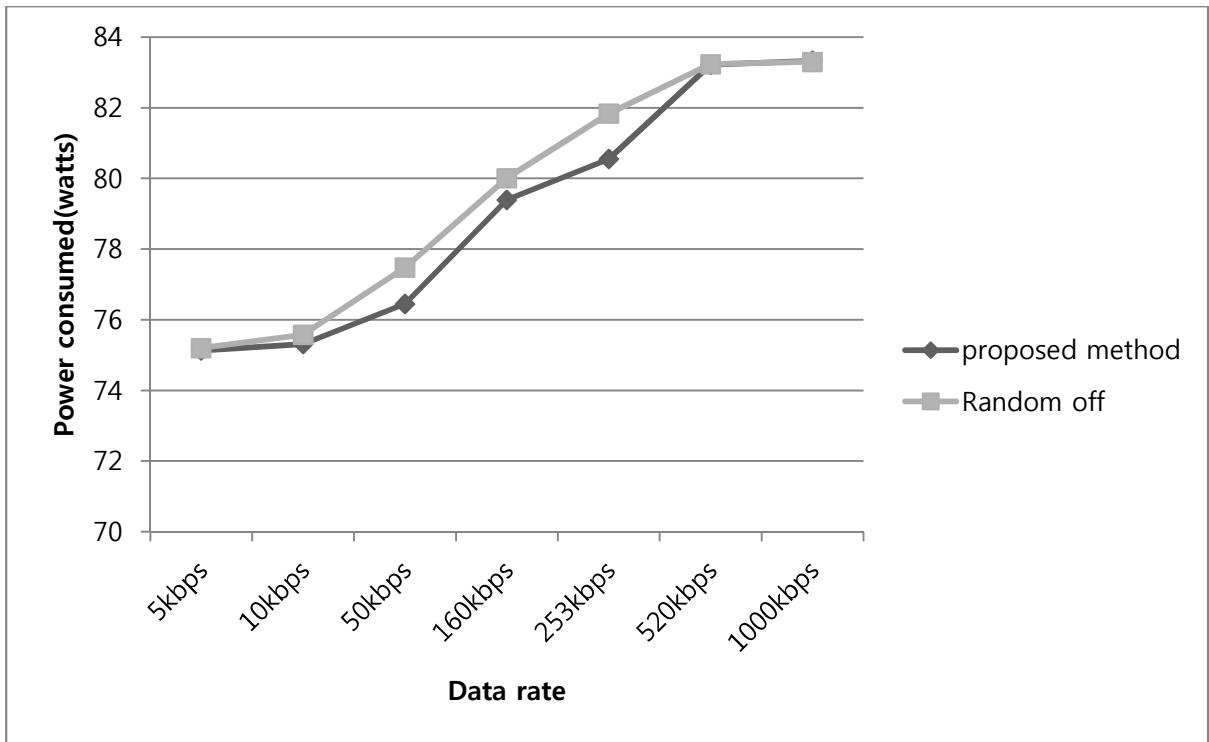

(b) Maximized view of random and proposed method

Figure 6.5: Analysis of power consumption vs. data rates.

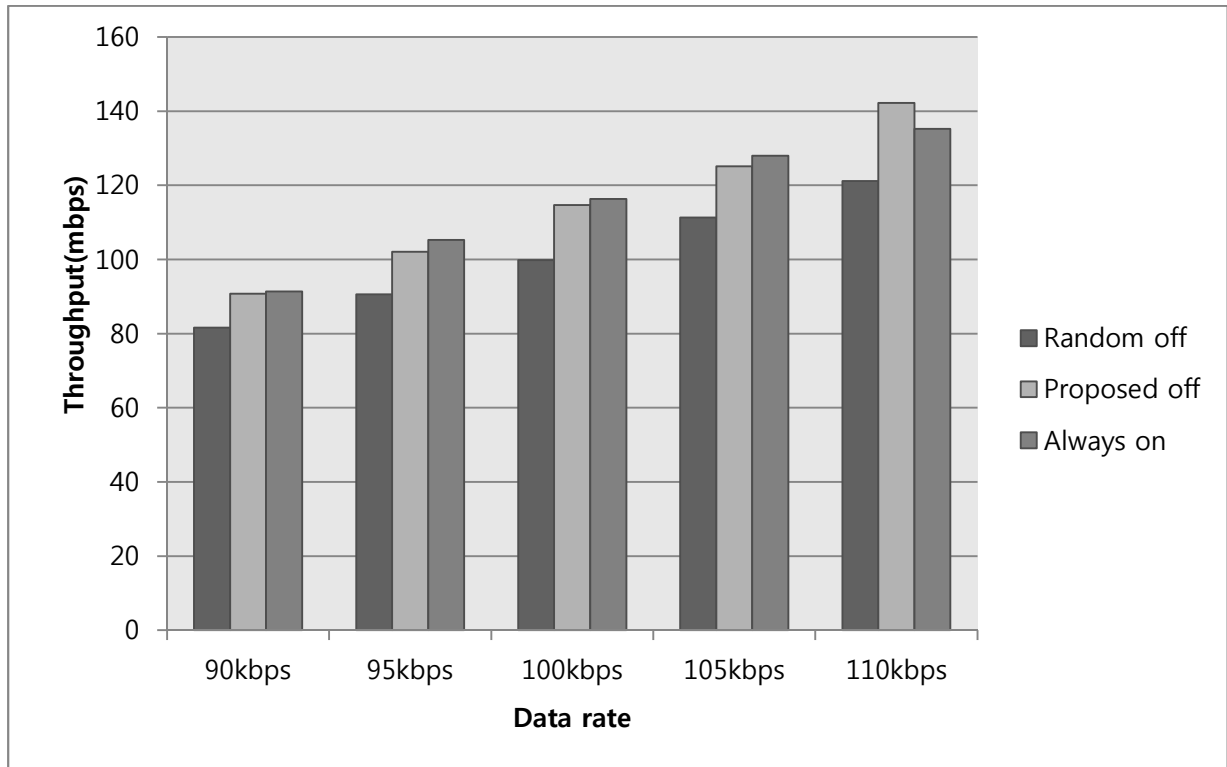

Figure 6.6: Analysis of throughput vs. data rates.

VII. CONCLUSION

This paper proposed the power saving scheme by turning off unnecessary APs for wireless access networks where many APs, each providing full coverage and service during peak traffic time, but offering redundant resources when traffic load is low. We introduced a distance-aware algorithm that achieves a significant reduction in power consumption, without compromising the offered QoS. In particular, we proved how important is to efficiently choose the APs to be switched off during low traffic periods, by considering the distance of the UEs from the APs. Our results indicated that we can save up to average of 30% to 40% of the power consumed to operate the network, by decreasing the number of the active APs during low traffic periods.

The most important message of this paper is that the energy wasted in large-scale and high-density WLANs is a new and serious concern. We stress those energy-efficient mechanisms for large-scale and high-density WLANs should be designed and developed today – to save energy in future WLANs and thus avoid the escalation of energy wastage.

REFERENCES

- [1] A. Bianzino, C. Chaudet, D. Rossi, and J. Rougier, "A Survey of Green Networking Research," IEEE Communication Surveys and Tutorials, 2012.
- [2] Global e-Sustainability Initiative (GeSI), "SMART 2020: Enabling the Low Carbon Economy in the Information Age",
<http://www.theclimategroup.org/assets/resources/publications/Smart2020Report.pdf>.
- [3] H. Toure, "ICTs and Climate Change—the ITU perspective", Climate Action 2008, www.climateactionprogramme.org
- [4] A. P. Jardosh, K. Papagiannaki, E. Belding, K. Almeroth, G. Iannaccone, B. Vinnakota, "Green WLANs: On-demand WLAN Infrastructures," Mobile Networks and Applications Journal, Springer Netherlands, Dec.2008.
- [5] Cali, M. Conti, and E. Gregori, "Dynamic tuning of the IEEE 802.11 protocol to achieve a theoretical throughput limit," IEEE/ACM Transactions on networking, vol. 8, pp. 785-799, 2000.
- [6] T. S. Rappaport, "Mobile radio propagation: Large-scale path loss," in Wireless communication: Principles & Practice, 2nd ed, 2002, pp. 105-177.
- [7] P. Barford, J. Chabarek, C. Estan, J. Sommers, D. Tsang, S. Wright, "Power Awareness in Network Design and Routing," IEEE INFOCOM 2008, Phoenix USA, April 2008.
- [8] P. Tsiaflakis, Y. Yi, M. Chiang, and M. Moonen, "Green DSL: Energy-Efficient DSM," IEEE ICC'09, Dresden, Germany, June 2009.
- [9] A. Qureshi, R. Weber, H. Balakrishnan, J. Gutttag and B. Maggs, "Cutting the Electric Bill for Internet-Scale Systems," ACM SIGCOMM 2009, Barcelona, Spain, August 2009.
- [10] L. Chiaraviglio, D. Ciullo, M. Meo, M. Ajmone Marsan, "Energy-Efficient

- Management of UMTS Access Networks*,” 21st International Teletraffic Congress (ITC 2009), Paris, France, September 2009.
- [11] Xinyu Zhang, Kang G. Shin, “*E-MiLi: energy-minimizing idle listening in wireless networks*”, Proceedings of the 17th annual international conference on Mobile computing and networking, September 19-23, 2011, Las Vegas, Nevada, USA.
- [12] W. Ye, J. Heidemann, and D. Estrin, “*Medium Access Control with Coordinated Adaptive Sleeping for Wireless Sensor Networks*”, IEEE/ACM Transactions on Networking (ToN), Vol. 12, n. 3, pp. 493-506, June 2004.
- [13] “*A Comparison of Efficiency, Throughput, and Energy Requirements of Wireless Access Points*”, <http://www.iol.unh.edu/services/testing/wireless>.
- [14] “*Sustainable Mobility: Cisco Strategies for Green Wireless*”, www.cisco.com/web/go/nextgen-wireless.
- [15] AA. Sayegh, T.D. Todd, “*Energy Management in Solar Powered WLAN Mesh Nodes Using Online Meteorological Data*,” IEEE ICC’07, Glasgow, UK, June 2007.
- [16] F. Zhang, T.D. Todd, D. Zhao, V. Kezys, “*Power Saving Access Points for IEEE 802.11 Wireless Network Infrastructure*”, IEEE Transactions on Mobile Computing, Vol. 5, n. 2, pp. 144-156, February 2006.
- [17] <http://meraki.com/news/2007/06/03/meraki-introduces-first-solar-powered-outdoor-wi-fi-access-kit/>.
- [18] A. P. Jardosh, G. Iannaccone, K. Papagiannaki, B. Vinnakota, “*Towards an Energy-Star WLAN Infrastructure*,” Proc. 8th Workshop on Mobile Computing Systems and Applications (HotMobile 2007), pp.85-90, Mar. 2007.
- [19] M. Ajmone Marsan, L. Chiaraviglio, D. Ciullo, M. Meo, “*Optimal Energy Savings in Cellular Access Networks*,” Proc. Green Communications Workshop in conjunction with IEEE ICC’09 (GreenComm09), Dresden, Germany, June 2009.

- [20] M. Ajmone Marsan, L. Chiaraviglio, D. Ciullo, M. Meo, "Energy-Aware UMTS Access Networks," Proc. First International Workshop on Green Wireless (WGREEN 2008) in conjunction with WPMC, Lapland, Finland, Sept. 2008.
- [21] Chen, J., Chan, G. H., He, J., and Liew, S., 2003, "Mixed-mode WLAN: The integration of ad hoc mode with wireless LAN infrastructure", Global Telecommunications Conference, GLOBECOM, Vol. 1, pp. 231-235.
- [22] Minhaj Uddin, "Power Management of Access Points", Osmania University, India, 2008 Thesis.
- [23] Chutima Prommak, "Demand Based Network Planning for Wlans", Khon Kaen University, 1992 M.S. in Interdisciplinary Telecommunications, University of Colorado at Boulder, 1998 Thesis.
- [24] Dinesh Ratan Gautam, "Enhanced Transmission Power Control Mechanism based on RSSI for MANET", International Journal of Computer Applications (0975-8887) Volume 28-No.1, August 2011.
- [25] Parameswaran, Ambili Thottam; Husain, M, I.; Upadhyaya, S. "Is RSSI a Reliable Parameter in Sensor Localization Algorithms – An Experimental Study". September 2009. 28th International Symposium On Reliable Distributed Systems, New York.
- [26] http://en.wikipedia.org/wiki/Received_signal_strength_indication.
- [27] R. Raghavendra, J. Padhye, and R. Mahajan, "Wi-Fi networks are underutilized. Technical report, Microsoft Research", August 2009.
- [28] D. Kotz and K. Essien, "Analysis of a campus-wide wireless network." In Proceedings of the ACM MobiCom, Sept. 2002

요 약 문

GREEN WLAN 을위한 에너지 인식 액세스 포인트 관리

지난 수십 년 동안 무선통신은 엄청난 성장을 해왔으며, 현재 일상생활에 기본이 되고 있다. 하지만 전례 없는 성장과 함께 상시 사용 모델로 인해 표준은 많은 양의 에너지 소비에 책임이 있다. 이산화탄소 배출량 및 운영 에너지 비용 감축을 위한 Access Points (APs)의 에너지 소비 최적화는 많은 연구단체와 정부나 산업에서 새로운 과제가 되고 있다. 이런 맥락에서, 기업이나 대학에서 무선 근거리 통신망은 높은 대역폭과 이동성과 안정성에 대한 사용자의 요구를 충족하기 위해 수백에서 수천 개의 AP 로 구성되어 있다. 또한 이렇게 연결된 네트워크는 러시아워 같은 시간에는 큰 차이로 평균 사용량을 초과하여 공급된다. 또한 이러한 차이는 아주 짧은 시간 동안만 도달하거나 거의 도달하지 못하는 경우가 많다. 전세계의 많은 무선 근거리 통신망이 이 문제를 가지고 있으며, 유휴 상태로 오래 머물러 있을 때 에너지 손실문제를 초래한다. 이 문제를 해결하기 위해, 본 논문에서는 Wi-Fi 네트워크에서 에너지 효율 향상이라는 과제에 기여하고자 한다. 특히 우리는 최상의 사용자 경험을 유지하면서 사용자장비와 서비스중인 AP 의 거리에 대한 정보를 이용하여 동적으로 특정 AP 의 전원을 끄는 에너지 효율을 위한 알고리즘을 제안한다. 네트워크 설계는 주로 중앙 통제 형 구조의 장점과 적절한 무선 신호의 범위와 서비스 영역에서 사용자 트래픽 수요를 제공하기 위해 필요한 데이터 속도 용량을 제공을 바탕으로 평가 되었다. 제안한 알고리즘은 ns-2 를 사용하여 시뮬레이션 하였다. 제안한 문제해결 방법은 전체 네트워크 처리량을 대폭 감소시키지 않으면서도 기존 대비 30%까지의 상당한 전력 절감을 얻을 수 있었다.

핵심어: 무선 근거리 통신망, Access Points (APs), Energy efficiency, Received signal strength indication (RSSI).

ACKNOWLEDGMENT

I would like to take this opportunity to thank all the wonderful people who have played a significant role in my years as a graduate student. Firstly, I would like to thank my graduate advisor, my role model and guru Prof. Kyung Joon Park. I have always been awed, inspired and motivated by his vision, simplicity and timely words of encouragement and I feel honored to have been associated with him.

I would like to thank my co–advisor Prof. Hangsoo Choi and Prof Jihwan Choi for accepting to be the committee members in my thesis defense and for helping to improve my work through their advice and ideas. I thank all the faculty and staff of ICE department at DGIST for their help and support.

I was lucky to have wonderful lab mates in CSI group: Sunghwa Son, Sol Yoon, Wonhong Jeon, Byeong Moon Cho, Dohwan Kim and Kyoung Nam Park who are my family in the Korea and I cannot thank them enough for their show of love and support in all my endeavors. I want to thank my friend Rakesh Shrestha, for his support and comments.

Finally, I owe a great debt of gratitude to my parents for making me a confident person and developing in me the unquenchable thirst of knowledge.