

01 Dec 2001

## Energy Storage Systems for Advanced Power Applications

Aysen Arsoy

Yilu Liu

Paul F. Ribeiro

Brian K. Johnson

*et. al.* For a complete list of authors, see [https://scholarsmine.mst.edu/ele\\_comeng\\_facwork/1013](https://scholarsmine.mst.edu/ele_comeng_facwork/1013)

Follow this and additional works at: [https://scholarsmine.mst.edu/ele\\_comeng\\_facwork](https://scholarsmine.mst.edu/ele_comeng_facwork)

 Part of the [Electrical and Computer Engineering Commons](#)

---

### Recommended Citation

A. Arsoy et al., "Energy Storage Systems for Advanced Power Applications," *Proceedings of the IEEE*, vol. 89, no. 12, pp. 1744-1756, Institute of Electrical and Electronics Engineers (IEEE), Dec 2001.

The definitive version is available at <https://doi.org/10.1109/5.975900>

This Article - Journal is brought to you for free and open access by Scholars' Mine. It has been accepted for inclusion in Electrical and Computer Engineering Faculty Research & Creative Works by an authorized administrator of Scholars' Mine. This work is protected by U. S. Copyright Law. Unauthorized use including reproduction for redistribution requires the permission of the copyright holder. For more information, please contact [scholarsmine@mst.edu](mailto:scholarsmine@mst.edu).

# Energy Storage Systems for Advanced Power Applications

PAULO F. RIBEIRO, SENIOR MEMBER, IEEE, BRIAN K. JOHNSON, MEMBER, IEEE,  
MARIESA L. CROW, SENIOR MEMBER, IEEE, AYSEN ARSOY, AND YILU LIU, SENIOR MEMBER, IEEE

## Invited Paper

*While energy storage technologies do not represent energy sources, they provide valuable added benefits to improve stability, power quality, and reliability of supply. Battery technologies have improved significantly in order to meet the challenges of practical electric vehicles and utility applications. Flywheel technologies are now used in advanced nonpolluting uninterruptible power supplies. Advanced capacitors are being considered as energy storage for power quality applications. Superconducting energy storage systems are still in their prototype stages but receiving attention for utility applications. The latest technology developments, some performance analysis, and cost considerations are addressed. This paper concentrates on the performance benefits of adding energy storage to power electronic compensators for utility applications.*

**Keywords**—Battery energy storage, custom power, energy storage system, flexible ac transmission systems (FACTS), flywheel energy storage, high voltage dc transmission (HVDC), hypercapacitor, power electronics, supercapacitor, superconducting magnetic energy storage, ultracapacitor.

## I. INTRODUCTION

Electric power systems are experiencing dramatic changes in operational requirements as a result of deregulation. Continuing electric load growth and higher regional power transfers in a largely interconnected network lead to complex and less secure power system operation. Power

generation and transmission facilities have not been able to grow to meet these new demands as a result of economic, environmental, technical, and governmental regulation constraints. At the same time, the growth of electronic loads has made the quality of power supply a critical issue. Power system engineers facing these challenges seek solutions to allow them to operate the system in a more flexible, controllable manner.

When power system disturbances occur, synchronous generators are not always able to respond rapidly enough to keep the system stable. If high-speed real or reactive power control is available, load shedding or generator drooping may be avoided during the disturbance. High speed reactive power control is possible through the use of flexible ac transmission systems (FACTS) devices. In a few cases, these devices are also able to provide some measure of high speed real power control through power circulation within the converter, with the real power coming from the same line or in some cases from adjacent lines leaving the same substation. However, a better solution would be to have the ability to rapidly vary real power without impacting the system through power circulation. This is where energy storage technology can play a very important role in maintaining system reliability and power quality. The ideal solution is to have means to rapidly damp oscillations, respond to sudden changes in load, supply load during transmission or distribution interruptions, correct load voltage profiles with rapid reactive power control, and still allow the generators to balance with the system load at their normal speed. Custom power devices use power converters to perform either current interruption or voltage regulation functions for power distribution systems.

Recent developments and advances in energy storage and power electronics technologies are making the application of energy storage technologies a viable solution for modern power applications. Viable storage technologies include batteries, flywheels, ultracapacitors, and superconducting energy storage systems. Although several of these technolo-

Manuscript received February 15, 2001; revised May 23, 2001. This work was supported in part by the National Science Foundation, in part by the Department of Energy under Grant DE-FG36-94GO10011, and in part by BWX Technologies, Inc.—Naval Nuclear Fuel Division.

P. F. Ribeiro is with the Engineering Department, Calvin College, Grand Rapids, MI 49546 USA.

B. K. Johnson is with the Department of Electrical and Computer Engineering, University of Idaho, Moscow, ID 83844-1023 USA.

M. L. Crow is with the Department of Electrical and Computer Engineering, University of Missouri-Rolla, Rolla, MO 65409 USA.

A. Arsoy is with the Department of Electrical Engineering, Kocaeli University, Izmit 41100, Kocaeli, Turkey.

Y. Liu is with the Department of Electrical and Computer Engineering, Virginia Polytechnic Institute and State University, Blacksburg, VA 24061 USA.

Publisher Item Identifier S 0018-9219(01)10838-8.

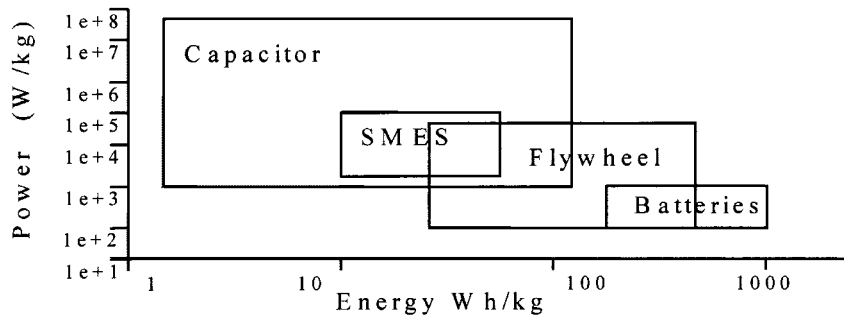

Fig. 1. Specific power versus specific energy ranges for near-to-midterm technology.

gies were initially envisioned for large-scale load-leveling applications, energy storage is now seen more as a tool to enhance system stability, aid power transfer, and improve power quality in power systems.

## II. ENERGY STORAGE SYSTEMS FOR TRANSMISSION AND DISTRIBUTION APPLICATIONS

Electrical energy in an ac system cannot be stored electrically. However, energy can be stored by converting the ac electricity and storing it electromagnetically, electrochemically, kinetically, or as potential energy. Each energy storage technology usually includes a power conversion unit to convert the energy from one form to another. Two factors characterize the application of an energy storage technology. One is the amount of energy that can be stored in the device. This is a characteristic of the storage device itself. Another is the rate at which energy can be transferred into or out of the storage device. This depends mainly on the peak power rating of the power conversion unit, but is also impacted by the response rate of the storage device itself.

The power/energy ranges for near-to-midterm technologies are projected in Fig. 1. Integration of these four possible energy storage technologies with flexible ac transmission systems (FACTS) and custom power devices are among the possible power applications utilizing energy storage. The possible benefits include: transmission enhancement, power oscillation damping, dynamic voltage stability, tie line control, short-term spinning reserve, load leveling, under-frequency load shedding reduction, circuit break reclosing, subsynchronous resonance damping, and power quality improvement.

### A. Superconducting Magnetic Energy Storage (SMES)

Although superconductivity was discovered in 1911, it was not until the 1970s that SMES was first proposed as an energy storage technology for power systems [1]. SMES systems have attracted the attention of both electric utilities and the military due to their fast response and high efficiency (a charge–discharge efficiency over 95%). Possible applications include load leveling, dynamic stability, transient stability, voltage stability, frequency regulation, transmission capability enhancement, and power quality improvement.

When compared with other energy storage technologies, today’s SMES systems are still costly. However, the integration of an SMES coil into existing FACTS devices eliminates the cost for the inverter unit, which is typically the largest portion of the cost for the entire SMES system. Previous studies have shown that micro (<0.1 MWh) and midsize (0.1–100 MWh) SMES systems could potentially be more economical for power transmission and distribution applications. The use of high temperature superconductors should also make SMES cost effective due to reductions in refrigeration needs. There are a number of ongoing SMES projects currently installed or in development throughout the world [2].

An SMES unit is a device that stores energy in the magnetic field generated by the dc current flowing through a superconducting coil. The inductively stored energy ( $E$  in joules) and the rated power ( $P$  in watts) are commonly given specifications for SMES devices, and they can be expressed as follows:

$$E = \frac{1}{2}LI^2 \quad P = \frac{dE}{dt} = LI\frac{dI}{dt} = VI$$

where  $L$  is the inductance of the coil,  $I$  is the dc current flowing through the coil, and  $V$  is the voltage across the coil. Since energy is stored as circulating current, energy can be drawn from an SMES unit with almost instantaneous response with energy stored or delivered over periods ranging from a fraction of a second to several hours.

An SMES unit consists of a large superconducting coil at the cryogenic temperature. This temperature is maintained by a cryostat or dewar that contains helium or nitrogen liquid vessels. A power conversion/conditioning system (PCS) connects the SMES unit to an ac power system, and it is used to charge/discharge the coil. Two types of power conversion systems are commonly used. One option uses a current source converter (CSC) to both interface to the ac system and charge/discharge the coil. The second option uses a voltage source converter (VSC) to interface to the ac system and a dc–dc chopper to charge/discharge the coil. The VSC and dc–dc chopper share a common dc bus. The components of an SMES system are shown in Fig. 2. The modes of charge/discharge/standby are obtained by controlling the voltage across the SMES coil ( $V_{\text{coil}}$ ). The SMES coil is charged or discharged by applying a positive or negative voltage,  $V_{\text{coil}}$ , across the superconducting coil. The SMES system enters a standby mode operation when

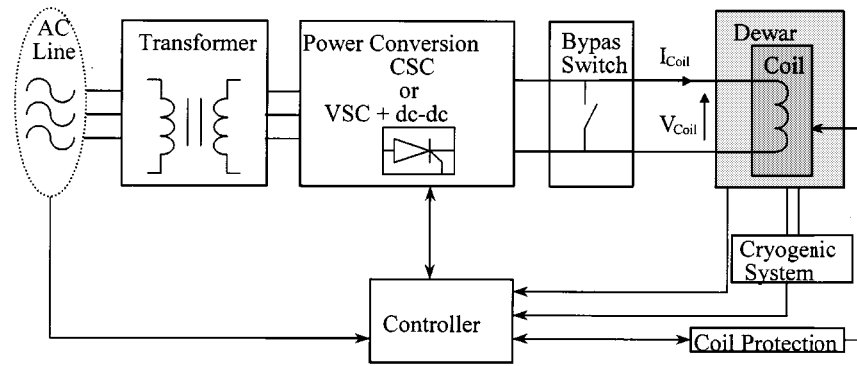

Fig. 2. Components of a typical SMES system.

the average  $V_{\text{coil}}$  is zero, resulting in a constant average coil current,  $I_{\text{coil}}$ .

Several factors are taken into account in the design of the coil to achieve the best possible performance of an SMES system at the least cost [3], [4]. These factors may include coil configuration, energy capability, structure, and operating temperature. A compromise is made between each factor considering the parameters of energy/mass ratio, Lorentz forces, stray magnetic field, and minimizing the losses for a reliable, stable, and economic SMES system. The coil can be configured as a solenoid or a toroid. The solenoid type (as shown in Fig. 3 [5]) has been used widely due to its simplicity and cost effectiveness, though the toroid-coil designs were also incorporated by a number of small-scale SMES projects. Coil inductance ( $L$ ) or PCS maximum voltage ( $V_{\text{max}}$ ) and current ( $I_{\text{max}}$ ) ratings determine the maximum energy/power that can be drawn or injected by an SMES coil. The ratings of these parameters depend on the application type of SMES. The operating temperature used for a superconducting device is a compromise between cost and the operational requirements. Low temperature superconductor devices (LTS) are available now, while high temperature superconductor devices are currently in the development stage.

SMES's efficiency and fast response capability (milliwatts/millisecond) have been, and can be further exploited in applications at all levels of electric power systems. The potential utility applications have been studied since the 1970s [6]. SMES systems have been considered for the following: 1) load leveling; 2) frequency support (spinning reserve) during loss of generation; 3) enhancing transient and dynamic stability; 4) dynamic voltage support (VAR compensation); 5) improving power quality; and 6) increasing transmission line capacity, thus enhancing overall reliability of power systems. Further development continues in power conversion systems and control schemes [7], evaluation of design and cost factors [8], and analyses for various SMES system applications. The energy–power characteristics for potential SMES applications for generation, transmission, and distribution are depicted in Fig. 4. The square area in the figure represents the applications that are currently economical. Therefore, the SMES technology has a unique advantage in two types of application: power

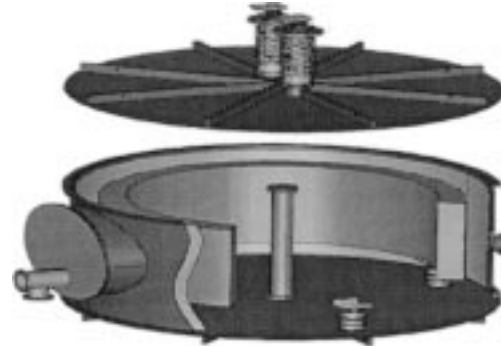

Fig. 3. Solenoid configuration.

system transmission control and stabilization and power quality.

The cost of an SMES system can be separated into two independent components where one is the cost of the energy storage capacity and the other one is the cost of the power handling capability. Storage related cost includes the capital and construction costs of conductor, coil structure components, cryogenic vessel, refrigeration, protection, and control equipment. Power related cost has the capital and construction costs of the power conditioning system. While the power related cost is lower than energy related cost for large-scale applications, it is more dominant for small-scale applications.

### B. Battery Energy Storage Systems (BESS)

Batteries are one of the most cost-effective energy storage technologies available, with energy stored electrochemically. A battery system is made up of a set of low-voltage/power battery modules connected in parallel and series to achieve a desired electrical characteristic. Batteries are “charged” when they undergo an internal chemical reaction under a potential applied to the terminals. They deliver the absorbed energy, or “discharge,” when they reverse the chemical reaction. Key factors of batteries for storage applications include: high energy density, high energy capability, round trip efficiency, cycling capability, life span, and initial cost [9].

There are a number of battery technologies under consideration for large-scale energy storage. Lead-acid batteries represent an established, mature technology. Lead-acid

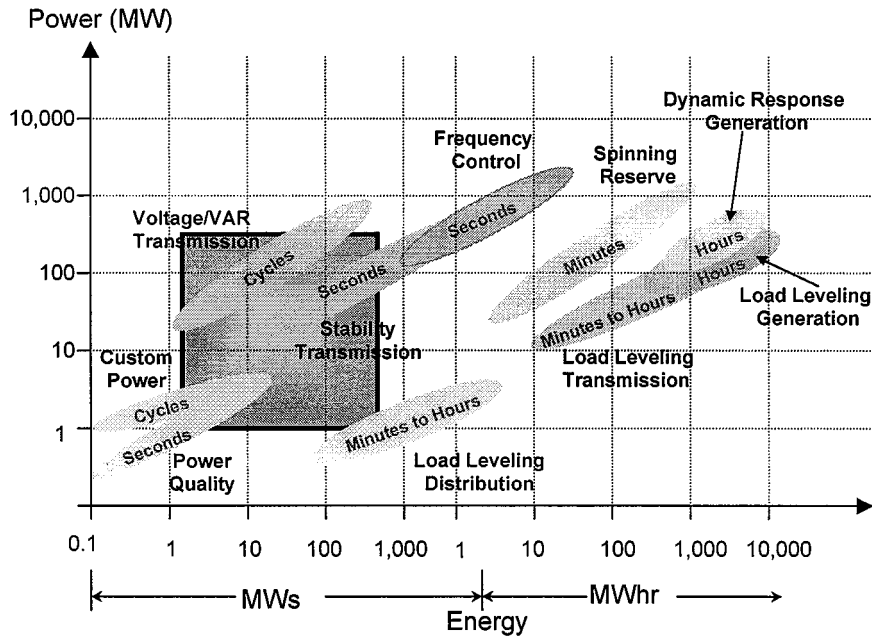

Fig. 4. Energy–power characteristics of potential SMES applications.

batteries can be designed for bulk energy storage or for rapid charge/discharge. Improvements in energy density and charging characteristics are still an active research area, with different additives under consideration. Lead-acid batteries still represent a low-cost option for most applications requiring large storage capabilities, with the low energy density and limited cycle life as the chief disadvantages. Mobile applications are favoring sealed lead-acid battery technologies for safety and ease of maintenance. Valve regulated lead-acid (VRLA) batteries have better cost and performance characteristics for stationary applications.

Several other battery technologies also show promise for stationary energy storage applications. All have higher energy density capabilities than lead-acid batteries, but at present, they are not yet cost effective for higher power applications. Leading technologies include nickel–metal hydride batteries, nickel–cadmium batteries, and lithium-ion batteries. The last two technologies are both being pushed for electric vehicle applications where high energy density can offset higher cost to some degree.

Due to the chemical kinetics involved, batteries cannot operate at high power levels for long time periods. In addition, rapid, deep discharges may lead to early replacement of the battery, since heating resulting in this kind of operation reduces battery lifetime. There are also environmental concerns related to battery storage due to toxic gas generation during battery charge/discharge. The disposal of hazardous materials presents some battery disposal problems. The disposal problem varies with battery technology. For example, the recycling/disposal of lead acid batteries is well established for automotive batteries.

Batteries store dc charge, so power conversion is required to interface a battery with an ac system. Small, modular batteries with power electronic converters can provide four-quadrant operation (bidirectional current flow and bidi-

rectional voltage polarity) with rapid response. Advances in battery technologies offer increased energy storage densities, greater cycling capabilities, higher reliability, and lower cost [10]. Battery energy storage systems (BESS) have recently emerged as one of the more promising near-term storage technologies for power applications, offering a wide range of power system applications such as area regulation, area protection, spinning reserve, and power factor correction [11]. Several BESS units have been designed and installed in existing systems for the purposes of load leveling, stabilizing, and load frequency control [12]. Optimal installation site and capacity of BESS can be determined depending upon its application. This has been done for load leveling applications. Also, the integration of battery energy storage with a FACTS power flow controller can improve the power system operation and control.

### C. Advanced Capacitors

Capacitors store electric energy by accumulating positive and negative charges (often on parallel plates) separated by an insulating dielectric. The capacitance,  $C$ , represents the relationship between the stored charge,  $q$ , and the voltage between the plates,  $V$ , as shown in (1). The capacitance depends on the permittivity of the dielectric,  $\epsilon$ , the area of the plates,  $A$ , and the distance between the plates,  $d$ , as shown in (2). Equation (3) shows that the energy stored on the capacitor depends on the capacitance and on the square of the voltage

$$q = CV \quad (1)$$

$$C = \frac{\epsilon A}{d} \quad (2)$$

$$E = \frac{1}{2} CV^2 \quad (3)$$

$$dV = i * \frac{dt}{C_{tot}} + i * R_{tot}. \quad (4)$$

The amount of energy a capacitor is capable of storing can be increased by either increasing the capacitance or the voltage stored on the capacitor. The stored voltage is limited by the voltage-withstand-strength of the dielectric (which impacts the distance between the plates). Capacitance can be increased by increasing the area of the plates, increasing the permittivity, or decreasing the distance between the plates. As with batteries, the turnaround efficiency when charging/discharging capacitors is also an important consideration, as is response time. The effective series resistance (ESR) of the capacitor has a significant impact on both. The total voltage change when charging or discharging capacitors is shown in (4). Note that  $C_{tot}$  and  $R_{tot}$  are the result from a combined series/parallel configuration of capacitor cells to increase the total capacitance and the voltage level. The product  $R_{tot}C_{tot}$  determines the response time of the capacitor for charging or discharging.

Capacitors are used in many ac and dc applications in power systems. DC storage capacitors can be used for energy storage for power applications. They have long seen use in pulsed power applications for high-energy physics and weapons applications. However, the present generation of dc storage capacitors sees limited use as large-scale energy storage devices for power systems. Capacitors are often used for very short-term storage in power converters. Additional capacitance can be added to the dc bus of motor drives and consumer electronics to provide added ability to ride voltage sags and momentary interruptions. The main transmission or distribution system application where conventional dc capacitors are used as large-scale energy storage is in the distribution dynamic voltage restorer (DVR), a custom power device that compensates for temporary voltage sags on distribution systems [13]. The power converter in the DVR injects sufficient voltage to compensate for the voltage sag, such that loads connected to the system are isolated from the sag. The DVR uses energy stored in dc capacitors to supply a component of the real power needed by the load.

Several varieties of advanced capacitors are in development, with several available commercially for low power applications. These capacitors have significant improvements in one or more of the following characteristics: higher permittivities, higher surface areas, or higher voltage-withstand capabilities.

Ceramic hypercapacitors have both a fairly high voltage-withstand (about 1 kV) and a high dielectric strength, making them good candidates for future storage applications. At present, they are largely used in low power applications. In addition, hypercapacitors have low effective-series-resistance values. Cryogenic operation appears to offer significant performance improvements. The combination of higher voltage-withstand and low effective-series-resistance will make it easier to use hypercapacitors in high power applications with simpler configurations possible [14].

Ultracapacitors (also known as supercapacitors) are double layer capacitors that increase energy storage capability due to a large increase in surface area through use of a porous electrolyte (they still have relatively low permittivity

and voltage-withstand capabilities) [15]. Several different combinations of electrode and electrolyte materials have been used in ultracapacitors, with different combinations resulting in varying capacitance, energy density, cycle-life, and cost characteristics. At present, ultracapacitors are most applicable for high peak-power, low-energy situations. Capable of floating at full charge for ten years, an ultracapacitor can provide extended power availability during voltage sags and momentary interruptions. Ultracapacitors can be stored completely discharged, installed easily, are compact in size, and can operate effectively in diverse (hot, cold, and moist) environments. Ultracapacitors are now available commercially at lower power levels [16].

As with battery energy storage systems, application of capacitors for power applications will be influenced by the ability to charge/discharge the storage device. At present, ultracapacitors and hypercapacitors have seen initial application in low-energy applications with much of the development for higher energy applications geared toward electric vehicles. Near-term applications will most likely use these capacitors in power quality applications. For example, ultracapacitors can be added to the dc bus of motor drives to improve ride-through times during voltage sags [17], [18]. Ultracapacitors can also be added to a DVR or be interfaced to the dc bus of a distribution static compensator (DStatCom) [19], [20].

#### D. Flywheel Energy Storage (FES)

Flywheels can be used to store energy for power systems when the flywheel is coupled to an electric machine. In most cases, a power converter is used to drive the electric machine to provide a wider operating range. Stored energy depends on the moment of inertia of the rotor and the square of the rotational velocity of the flywheel, as shown in (5). The moment of inertia ( $I$ ) depends on the radius, mass, and height (length) of the rotor, as shown in (6). Energy is transferred to the flywheel when the machine operates as a motor (the flywheel accelerates), charging the energy storage device. The flywheel is discharged when the electric machine regenerates through the drive (slowing the flywheel)

$$E = \frac{1}{2}I\omega^2 \quad (5)$$

$$I = \frac{r^2mh}{2}. \quad (6)$$

The energy storage capability of flywheels can be improved either by increasing the moment of inertia of the flywheel or by turning it at higher rotational velocities, or both. Some designs utilize hollow cylinders for the rotor allowing the mass to be concentrated at the outer radius of the flywheel, improving storage capability with a smaller weight increase [21].

Two strategies have been utilized in the development of flywheels for power applications. One option is to increase the inertia by using a steel mass with a large radius, with rotational velocities up to approximately 10 000 rpm. A fairly standard motor and power electronic drive can be used as the power conversion interface for this type of flywheel. Several

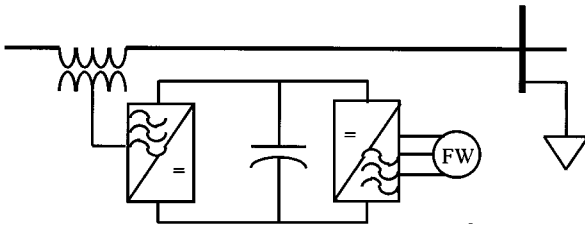

Fig. 5. Flywheel energy storage coupled to a dynamic voltage restorer.

flywheels utilizing this type of design are available commercially as uninterruptible power supplies (UPSs). This design results in relatively large, heavy flywheel systems. Rotational energy losses will also limit the long-term storage ability of this type of flywheel.

The second design strategy is to produce flywheels with a lightweight rotor turning at very high rotational velocities (up to 100 000 rpm) [22]–[24]. This approach results in compact, lightweight energy storage devices. Modular designs are possible, with a large number of small flywheels possible as an alternative to a few large flywheels [25]. However, rotational losses due to drag from air and bearing losses result in significant self-discharge, which poses problems for long-term energy storage. High-velocity flywheels are therefore operated in vacuum vessels to eliminate air resistance. The use of magnetic bearings helps improve the problems with bearing losses. Several projects are developing superconducting magnetic bearings for high-velocity flywheels [26]–[28]. The near elimination of rotational losses will provide flywheels with high charge/discharge efficiency. The peak power transfer ratings depend on the power ratings in the power electronic converter and the electric machine.

Flywheel applications under consideration include automobiles, buses, high-speed rail locomotives, and energy storage for electromagnetic catapults on next generation aircraft carriers. The high rotational velocity also results in the need for some form of containment vessel around the flywheel in case the rotor fails mechanically. The added weight of the containment can be especially important in mobile applications. However, some form of containment is necessary for stationary systems as well. The largest commercially available flywheel system is about 5 MJ/1.6 MVA weighing approximately 10 000 kg.

Flywheel energy storage can be implemented in several power system applications. If an FES system is included with a FACTS or custom power device with a dc bus, an inverter is added to couple the flywheel motor/generator to the dc bus. For example, a flywheel based on an ac machine could have an inverter interface to the dc bus of the custom power device, as shown in Fig. 5. Flywheel energy storage has been considered for several power system applications, including power quality applications [29]–[32] as well as peak shaving and stability enhancement [33].

#### E. Other Technologies

Several other energy storage technologies have been considered and applied for utility applications, including

pumped hydroelectric systems, compressed air energy storage (CAES), and flow batteries (a variation on the fuel cell now in the demonstration stage).

### III. POWER SYSTEMS APPLICATIONS

Currently, each storage technology has advantages and disadvantages when considered for power system applications. SMES systems are environmentally friendly and can respond rapidly to changes in power demand, but battery and flywheel systems are modular and cost effective. Flywheels and capacitor technologies are still being developed and are emerging as promising storage technologies as well. The capabilities of energy storage systems in power system applications are summarized in Table 1.

#### A. Integration of Energy Storage Systems Into FACTS Devices

Second generation FACTS controllers are power electronics based devices that can rapidly influence the transmission system parameters such as impedance, voltage, and phase to provide fast control of transmission or distribution system behavior. The multi-MW FACTS technologies have been introduced to the utility industry to enhance the existing transmission assets as opposed to construction of new transmission assets. Several utilities have installed such controllers in their system [25], [26]. The FACTS controllers that can benefit the most from energy storage are those that utilize a voltage source converter interface to the power system with a capacitor on a dc bus. This class of FACTS controllers can be connected to the transmission system in parallel (static compensator, or StatCom), series (static synchronous series compensator, or SSSC) or combined (unified power flow controller, or UPFC) form, and they can utilize or redirect the available power and energy from the ac system. Without energy storage, FACTS devices are limited in the degree of freedom and sustained action in which they can help the power grid. The integration of an energy storage system (ESS) into FACTS devices can provide independent real and reactive power absorption/injection into/from the grid, leading to a more economical and/or flexible transmission controller. The addition of real power transfer capability does not necessarily result in a large increase in the MVA rating of the converter, since the real power is in quadrature with the reactive power from the converter, as shown in Fig. 6. The addition of real power capability may improve the performance of the converter enough that the total converter MVA rating could even be reduced. If a transmission line experiences significant power transfer variations in a short time notice, a FACTS/ESS combination can be installed to relieve the loaded transmission line. The enhanced performance of combined FACTS/ESS will have greater appeal to transmission service providers (Fig. 7).

To illustrate the significant impact of FACTS/ESS, several simulation and experimental studies were carried out, with the results presented in the following sections. The first integrates a StatCom with an SMES for the damping dynamic

**Table 1**  
Summary of Energy Storage Systems Capabilities

Performance \ ESS	SMES	BESS	FES	Capacitor
Dynamic Stability	✓ [1, 2, 3, 4]	✓ [47]	✓ [5]	Needs to be explored
Transient Stability	✓ [6, 7]	✓ [47, 45]	✓ [8]	
Voltage Support	✓ [ ]	✓ [47, 46]	✓ [9]	
Area Control/ Frequency Regulation	✓ [10]	✓ [10, 11]	-	
Transmission Capability Improvement	✓ [11]	✓ [10, 12]	-	
Power Quality Improvement	✓ [8, 14]	✓ [13, 14, 15]	✓ [16, 17, 18]	✓ [ ]

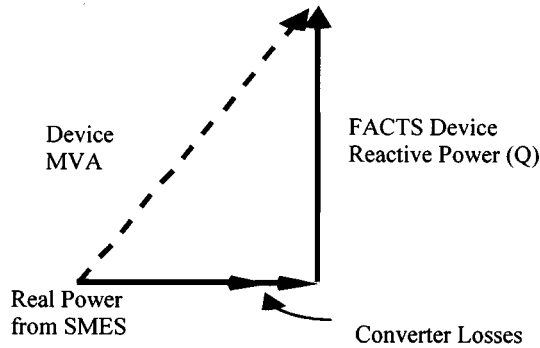

**Fig. 6.** Device MVA rating.

power oscillations. The second integrates various FACTS devices (StatCom, SSSC, and UPFC) with BESS for voltage control, power flow control, and oscillation damping.

*StatCom With SMES:* The dynamics of the integration of a  $\pm 160$  MVAR StatCom, and 100 MJ SMES coil (96 MW peak power and 24 kV dc interface) was modeled and simulated [27], [52]. The StatCom is modeled with two-GTO based six-pulse voltage source inverters. The voltage source inverters are connected to the ac system through two 80 MVA coupling transformers, and linked to a 10 mF dc capacitor in the dc side. The dc link capacitor establishes equilibrium between the instantaneous output and input power of the inverter. The SMES coil is connected to the voltage source inverter through a dc–dc chopper, as shown in Fig. 8. The chopper controls the dc current and voltage levels by converting the inverter dc output voltage to the adjustable voltage required across the SMES coil terminal. The purpose of the interphase inductors is to allow balanced current sharing for each chopper phase.

The StatCom/SMES is applied to a system with two synchronous areas coupled via parallel tielines. Dynamic oscillations of approximately 3 Hz are induced between the two areas by applying a 0.15 second three phase fault at the midpoint of one of the parallel lines. Fig. 9 shows the system dynamic response caused by the short circuit for the system with and without the StatCom/SMES.

Without a controller, the system response shown in Fig. 9(a) exhibits lightly damped oscillations in both frequency and generator rotor speed. Adding a StatCom to the system at the tieline bus stabilizes the voltage excursions,

but has little impact on damping the generator rotor oscillations. The reactive power injection capabilities of the StatCom enables the voltage to be rapidly controlled, but without active power capabilities, the rotor oscillations are relatively impervious to the effect of the StatCom. When an SMES coil is added to the StatCom, both the voltage and rotor oscillations are quickly damped. If the StatCom/SMES is placed close to the generator, the SMES coil acts as an energy booster for the generator and yields better damping performance.

*FACTS With BESS:* The independent control of both active and reactive power of a FACTS/BESS system make it an ideal candidate for many types of power system applications, including voltage control and oscillation damping. To show the effectiveness of the FACTS/BESS compared to a traditional FACTS system, a lightly damped mode at 1.4 Hz is induced between two synchronous areas shown in Fig. 10 by removing one of the interconnecting tielines.

For an even comparison between controllers, the same control approach was applied for both the FACTS and the FACTS/BESS system. The active power flow was controlled using a PI control where the target active power output of the FACTS/BESS is given by  $P^* = P_{\text{line}} - P_{\text{line, scheduled}}$ . The ideal control is to inject the FACTS/BESS active power in opposition to the tieline oscillations to rapidly damp them. The voltage control is accomplished using a linear-quadratic-regulator (LQR) control.

A comparison of the effectiveness of the controls is shown in Figs. 11 and 12. The presence of the lightly damped oscillatory mode can be observed in Fig. 11(a)–(c). Immediately following the loss of one of the parallel lines, the active power flow from area 1 to area 2 drops. This sudden topology change perturbs one of the interarea oscillatory modes, resulting in a lightly damped active power oscillation on the remaining tieline. However, since the total power demand and generation in the system do not change, the power flow from area 1 to area 2 will return to the scheduled value over time. To fully mitigate the resulting oscillations, the low frequency oscillatory mode must be sufficiently damped by the FACTS controllers. Note that in both power and voltage cases, the FACTS/BESS is more effective than any FACTS device alone. This is due to the additional degree of freedom in control and the presence of active power capabilities, especially in the interarea os-



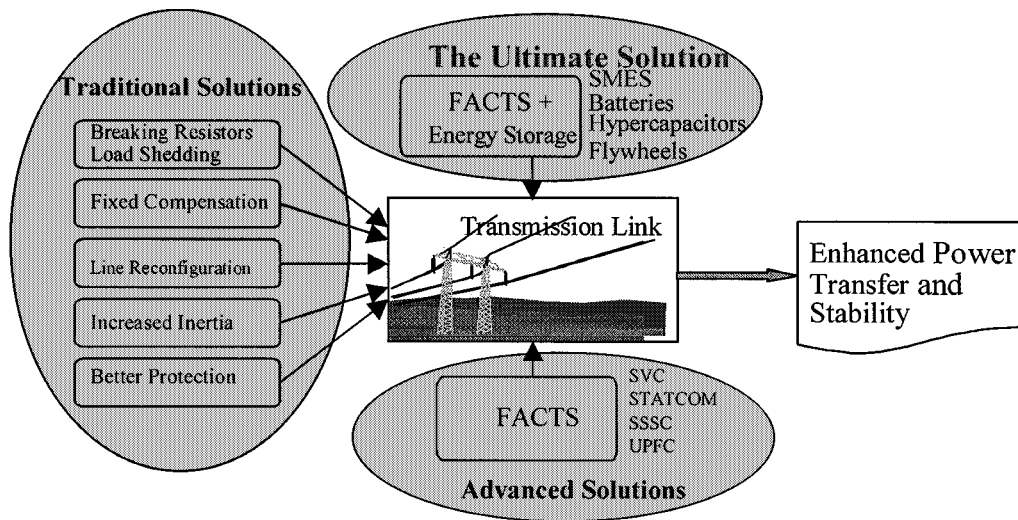

Fig. 7. The ultimate solution: FACTS + ESS.

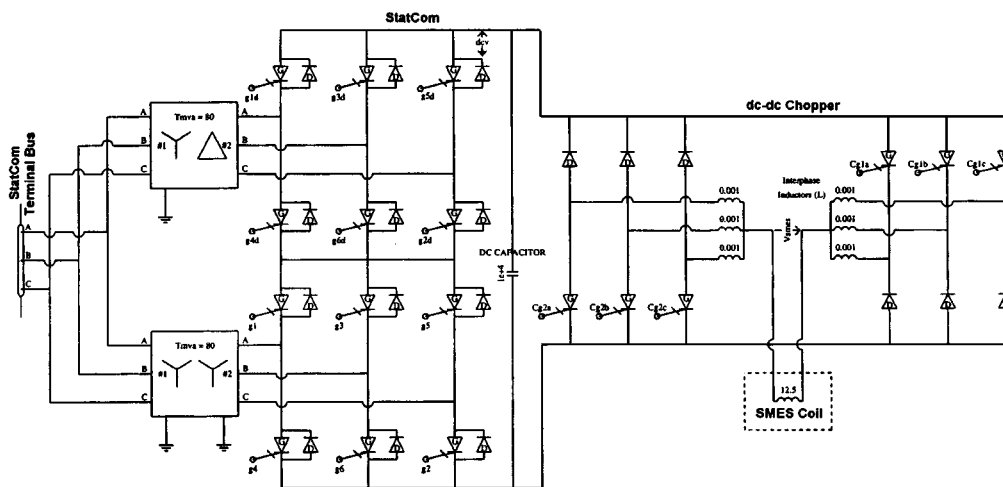

Fig. 8. Detailed representation of the StatCom, dc-dc chopper, and SMES coil.

cillation damping control. Since the FACTS/BESS has two degrees of control freedom, both control objectives can be met independently, whereas the StatCom and SSSC control must be optimized to achieve both the oscillation damping and the voltage control objectives with a single input.

These study results establish the viability of using FACTS/ESS to enhance power system operation [53]. The FACTS/ESS combination exhibits increased flexibility over the traditional FACTS with improved damping capabilities due to the additional degree of control freedom provided by energy storage systems.

### B. HVDC Transmission and Distribution Applications

Improvements in power electronic device technologies have led to significant improvements in the flexibility of dc transmission systems through the ability to use voltage source converters [54]. Traditional direct current systems see limited use as high power, high voltage dc (HVDC) transmission systems. These HVDC systems operate at high voltage levels to reduce resistive losses. The systems use line-commutated, thyristor-based converters and have fairly

simple point-to-point layouts with a single rectifier and a single inverter. More complicated multiterminal systems have been considered, but the complexity of a reliable control scheme allowing operation without communication during a disturbance severely limits the number of converters in the system.

Voltage source converter based dc systems allow for lower voltage dc transmission systems capable of supporting a large number of standard “off the shelf” inverters. Energy storage can be added to the dc system, providing improved response to fast load changes drawn by the inverters (see Fig. 13). The addition of energy storage to superconducting transmission systems is explored in [55], and battery storage to a dc distribution system based on voltage source converters is discussed in [56].

There are several key features that the dc system must possess to be able to provide high quality power to the loads. The system should try to emulate the desirable features of a UPS as far as the loads are concerned. Key features to include are: isolation from ac supply system voltage fluctuations, limiting nonlinear interactions with other loads and sources on

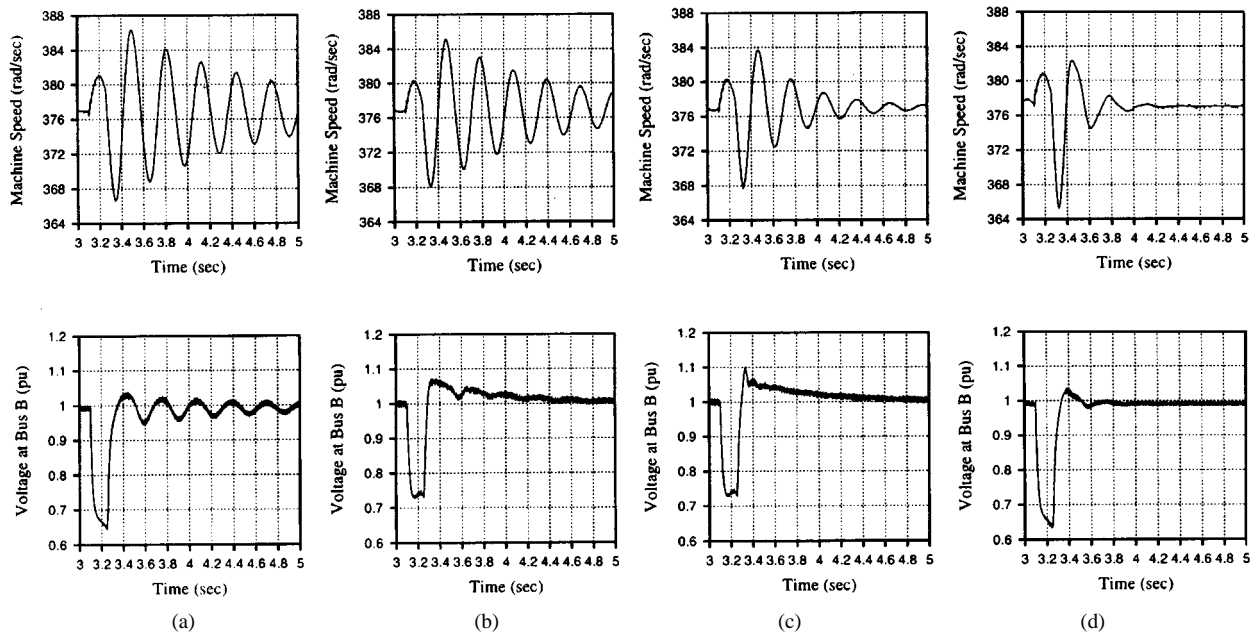

**Fig. 9.** StatCom/SMES dynamic response to ac system oscillations. (a) No compensation. (b) StatCom only at tieline bus. (c) StatCom/SMES at tieline bus. (d) StatCom/SMES at generator terminal.

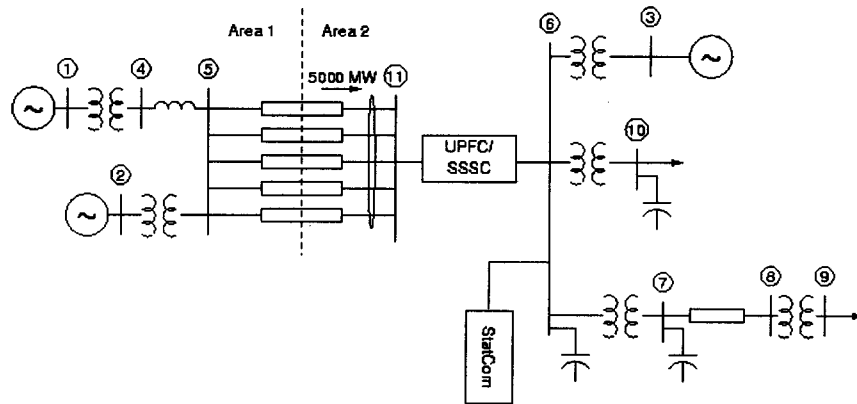

**Fig. 10.** Two area system for FACTS/BESS.

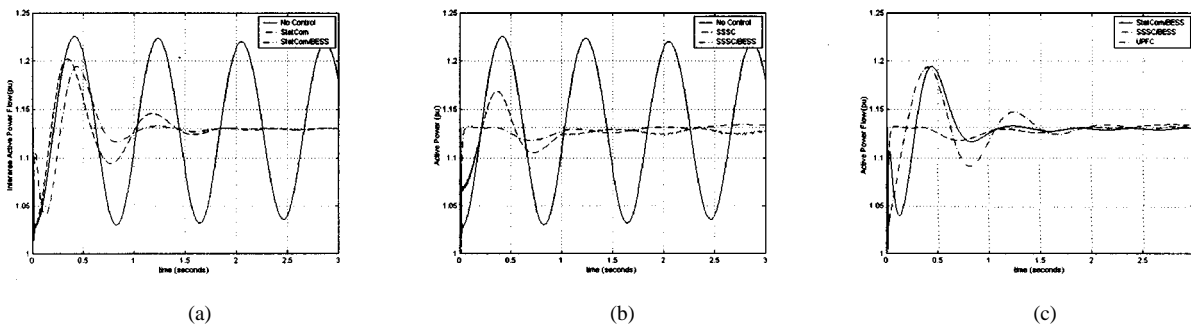
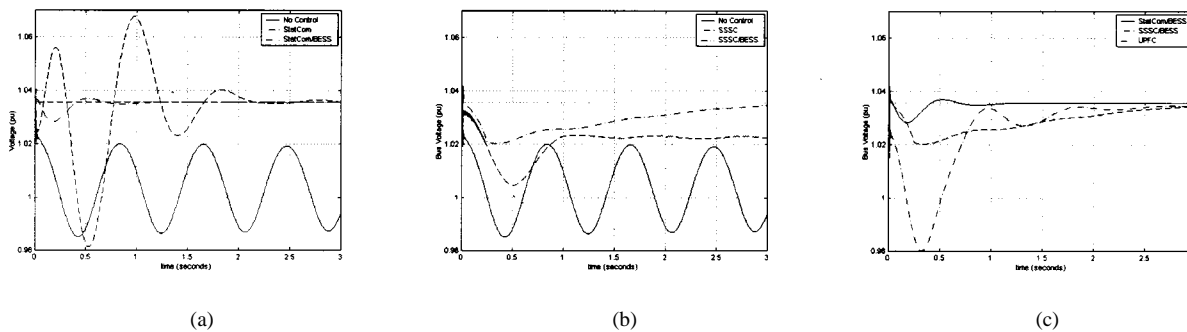

**Fig. 11.** Active power flow between areas. (a) StatCom versus StatCom/BESS. (b) SSSC versus SSSC/BESS. (c) StatCom/BESS versus SSSC/BESS versus UPFC.

the system, and ride-through capabilities for ac faults and interruptions. Disturbances on the dc system itself should also have minimum impact on the voltage waveforms seen by the loads.

The system should also have the ability to ride through voltage sags on the ac system. A small, subcycle sag can

be corrected for by the converter controls and the energy stored in the passive elements in the system. But a longer lasting voltage sag or an outright interruption requires the presence of some form of energy storage on the dc system. The storage element will be interfaced to the dc system through a power converter. The converter will be controlled



**Fig. 12.** Voltage at area 2 bus (6). (a) StatCom versus StatCom/BESS. (b) SSSC versus SSSC/BESS. (c) StatCom/BESS versus SSSC/BESS versus UPFC.

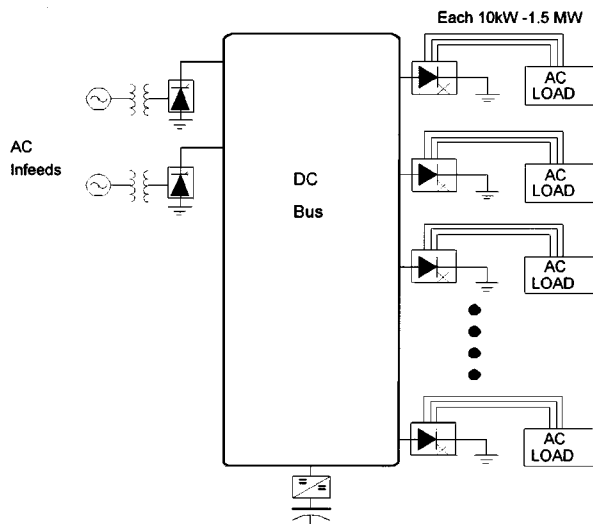
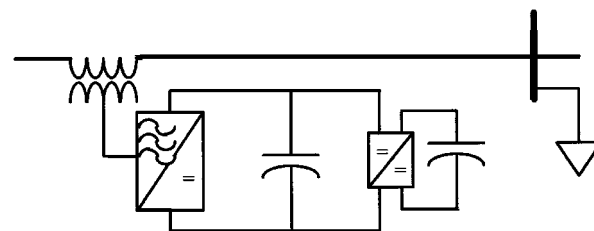

**Fig. 13.** DC system with capacitive energy storage added to the dc system through a dc-to-dc converter.

to keep the storage element charged during normal operation and then support the dc voltage at a minimum level during a disturbance.

### C. Power Quality Enhancement With Energy Storage

Custom power devices address problems found at distribution level such as voltage sags, voltage swells, voltage transients, and momentary interruptions. The most common approaches to mitigate these problems focus on customer side solutions such as UPS systems based on battery energy storage. Alternative UPS systems based on SMES and FESs are also available. On the utility side of the meter, studies have indicated that using power line conditioners and redundant feeder systems operating in conjunction with fast acting circuit breakers and fault isolators can eliminate a majority of the load disruptions. Custom power devices are entering service to act as fast circuit breakers and perform line conditioning. The dynamic voltage restorer (DVR) is a pulswidth-modulated (PWM) converter in series with the lines, having a dc link stabilized by an energy storage element, usually a large capacitance. The DVR is distinguished by having a dc energy source, often dc storage capacitors, supplying the dc link as well, as shown in Fig. 14, although ultracapacitors, FES, and SMES can all be used to allow the DVR to operate over longer/deeper voltage sags. A distribution StatCom



**Fig. 14.** Dynamic voltage restorer (DVR) with capacitor storage.

(DStatCom) is similar to the DVR, except that the voltage source converter is connected in parallel with the line. Energy storage can also be added to the dc bus of the DStatCom.

## IV. COST CONSIDERATIONS

Energy storage system costs for a transmission application are driven by the operational requirements [57]–[63]. The costs of the system can be broken down into three main components: the energy storage system, the supporting systems (refrigeration for SMES is a big item), and the power conversion system. The cost of the energy storage system is primarily determined by the amount of energy to be stored. The configuration and the size of the power conversion system may become a dominant component for the high-power low-energy storage applications. For the utility applications under consideration, estimates are in the range of \$10K–\$100K per MJ for the storage system. The corresponding cost of supporting systems is within the range of \$2K–\$15K per MJ. The power conversion system is estimated to be in the range of \$150 to \$250 per kW. The reason for the wide variation in the cost of the power conversion system is its dependence on the configuration of the system. For example, if an SMES is connected to an ac system, a dc–dc chopper and a voltage source converter or a current source inverter is needed, but if the SMES is connected to an existing FACTS device with a dc bus, only the dc–dc chopper is required. Therefore, the percentage of relative cost of each subsystem with regard to the total system cost is dependent on the application.

In order to establish a realistic cost estimate, the following steps are suggested:

- identify the system issue(s) to be addressed;
- select preliminary system characteristics;
- define basic energy storage, power, voltage and current requirements;

- model system performance in response to system demands to establish effectiveness of the device;
- optimize system specification and determine system cost;
- determine utility financial benefits from operation;
- compare system's cost and utility financial benefits to determine adequacy of utility's return on investment;
- compare different energy storage systems performance and costs.

While each system will be tailored to individual utility needs, target costs for a basic energy storage system on a per kilowatt basis are less than the costs on a per kilowatt basis of the lowest cost generation units. On a per unit active or reactive power basis, energy storage costs will be higher than the costs for FACTS that do not provide the full range of services that a FACTS + Energy Storage device can provide.

Deregulation, together with transmission limitations and generation shortage, have recently changed the power grid condition creating situations where energy storage technology can play a very important role in maintaining system reliability and power quality. The ability to rapidly damp oscillations, respond to sudden changes in load, supply load during transmission or distribution interruptions, correct load voltage profiles with rapid reactive power control, and still allow the generators to balance with the system load at their normal speed, are among the benefits of energy storage devices.

## V. CONCLUSION

Among the potential performance benefits produced by advanced energy storage applications are improved system reliability, dynamic stability, enhanced power quality, transmission capacity enhancement, and area protection. An energy storage device can also have a positive cost and environmental impact by reducing fuel consumption and emissions through reduced line losses and reduced generation availability for frequency stabilization.

FACTS devices which handle both real and reactive power to achieve improved transmission system performance are multi-MW proven electronic devices now being introduced in the utility industry. In this environment, energy storage is a logical addition to the expanding family of FACTS devices.

As deregulation takes place, generation and transmission resources will be utilized at higher efficiency rates leading to tighter and moment-by-moment control of the spare capacities. Energy storage devices can facilitate this process, allowing the utility maximum utilization of utility resources.

The new power electronics controller devices will enable increased utilization of transmission and distribution systems with increased reliability. This increased reliance will result in increased investment in devices that make this asset more productive. Energy storage technology fits very well within the new environment by enhancing the potential application of FACTS, custom power, and power quality devices.

This paper shows that energy storage devices can be integrated to power electronics converters to provide power system stability, enhanced transmission capability, and im-

proved power quality. Adding energy storage to power electronics compensators not only enhances the performance of the device, but can also provide the possibility of reducing the MVA ratings requirements of the front-end power electronics conversion system. This is an important cost/benefit consideration when considering adding energy storage systems.

## REFERENCES

- [1] R. B. Boom and H. A. Peterson, "Superconductive energy storage for power systems," *IEEE Trans. Magn.*, vol. MAG-8, pp. 701–704, Sept. 1972.
- [2] R. F. Giese, "Progress toward high temperature superconducting magnetic energy storage (SMES) systems—A second look," Argonne National Laboratory, 1998.
- [3] —, "Progress toward high temperature superconducting magnetic energy storage (SMES) systems—A second look," Argonne National Laboratory, 1998.
- [4] C. A. Luongo, "Superconducting storage systems," *IEEE Trans. Magn.*, vol. 32, pp. 2214–2223, July 1996.
- [5] V. Karasik, K. Dixon, C. Weber, B. Batchelder, and P. Ribeiro, "SMES for power utility applications: A review of technical and cost considerations," *IEEE Trans. Appl. Superconduct.*, vol. 9, pp. 541–546, June 1999.
- [6] I. D. Hassan, R. M. Bucci, and K. T. Swe, "400 MW SMES power conditioning system development and simulation," *Trans. Power Electron.*, vol. 8, pp. 237–249, July 1993.
- [7] Q. Jiang and M. F. Conlon, "The power regulation of a PWM type superconducting magnetic energy storage unit," *IEEE Trans. Energy Conversion*, vol. 11, pp. 168–174, Mar. 1996.
- [8] D. Lieurance, F. Kimball, C. Rix, and C. Luongo, "Design and cost studies for small scale superconducting magnetic energy storage systems," *IEEE Trans. Appl. Superconduct.*, vol. 5, pp. 350–353, June 1995.
- [9] J. McDowall, "Conventional battery technologies—Present and future," in *Proc. 2000 IEEE Power Engineering Society Summer Meeting*, vol. 3, July 2000, pp. 1538–1540.
- [10] M. A. Casacca, M. R. Capobianco, and Z. M. Salameh, "Lead-acid battery storage configurations for improved available capacity," *IEEE Trans. Energy Conversion*, vol. 11, pp. 139–145, Mar. 1996.
- [11] N. W. Miller, R. S. Zrebiec, R. W. Delmerico, and G. Hunt, "Design and commissioning of a 5 MVA, 2.5 MWh battery energy storage," in *Proc. 1996 IEEE Power Engineering Society Transmission and Distribution Conf.*, 1996, pp. 339–345.
- [12] K.-H. Jung, H. Kim, and D. Rho, "Determination of the installation site and optimal capacity of the battery energy storage system for load leveling," *IEEE Trans. Energy Conversion*, vol. 11, pp. 162–167, Mar. 1996.
- [13] N. Abi-Samra, C. Neft, A. Sundaram, and W. Malcolm, "The distribution system dynamic voltage restorer and its applications at industrial facilities with sensitive loads," in *Proc. 8th Int. Power Quality Solutions '95*, Long Beach, CA, Sept. 9–15, 1995.
- [14] E. Schempp and W. D. Jackson, "Systems considerations in capacitive energy storage," in *Proc. 31st Intersociety Energy Conversion Engineering Conf.*, vol. 2, Aug. 1996, pp. 666–671.
- [15] G. L. Bullard, H. B. Sierra-Alcazar, H. L. Lee, and J. L. Morris, "Operating principles of the ultracapacitor," *IEEE Trans. Magn.*, vol. 25, pp. 102–106, Jan. 1989.
- [16] W. V. Hassenzahl, *Capacitors for Electric Utility Energy Storage*: Electric Power Res. Inst., 1997, vol. WO-8812.
- [17] M. Corley, J. Locker, S. Dutton, and R. Spee, "Ultracapacitor-based ride-through system for adjustable speed drives," in *Proc. 30th Annu. IEEE Power Electronics Specialists Conf. (PESC 99)*, vol. 1, June 1999, pp. 26–31.
- [18] P. Pillay, R. M. Samudio, M. Ahmed, and R. T. Patel, "A chopper-controlled SRM drive for reduced acoustic noise and improved ride through capability using supercapacitors," *IEEE Trans. Ind. Applicat.*, vol. 31, pp. 1029–1038, Sept./Oct. 1995.
- [19] I. Papic, P. Zunko, A. Krajnc, D. Povh, M. Weinhold, and R. Zurovski, "300 kW battery energy storage system using an IGBT converter," in *Proc. 1999 IEEE Power Engineering Society Summer Meeting*, July.
- [20] N. G. Hingorani, "Introducing custom power," *IEEE Spectr.*, pp. 41–48, June 1995.

- [21] P. Taylor, L. Johnson, K. Reichart, P. DiPietro, J. Philip, and P. Butler, "A summary of the state of the art of superconducting magnetic energy storage systems, flywheel energy storage systems, and compressed air energy storage systems," Sandia National Labs, SAND99-1854, 1999.
- [22] J. R. Hull, "Flywheels on a roll," *IEEE Spectr.*, pp. 20–25, July 1997.
- [23] J. G. Bitterly, "Flywheel technology: Past, present and 21st century projections," *IEEE AES Mag.*, pp. 13–16, Aug. 1998.
- [24] R. F. Post, T. K. Fowler, and S. F. Post, "A high-efficiency electro-mechanical battery," *Proc. IEEE*, vol. 81, pp. 462–474, Mar. 1993.
- [25] A. A. Miller, W. Qian, B. K. Johnson, J. D. Law, and R. W. Wall, "High speed locomotives with energy storage," in *Proc. 1997 North American Power Symp. (NAPS)*, Laramie, WY, Oct. 13–14, 1997, pp. 557–562.
- [26] T. M. Mulcahy, J. R. Hull, K. L. Uherka, and R. C. Niemann, "Flywheel energy storage advances using HTS bearings," *IEEE Trans. Appl. Superconduct.*, vol. 9, pp. 297–301, June 1999.
- [27] H. J. Bornemann and M. Sander, "Conceptual system design of a 5 MWh/100 MW superconducting flywheel energy storage plant for power utility applications," *IEEE Trans. Appl. Superconduct.*, vol. 7, pp. 398–401, June 1997.
- [28] J. D. Boyles and N. H. Clark, "Technologies for energy storage: Flywheels and superconducting magnetic energy storage," in *Proc. 2000 IEEE Power Engineering Society Summer Meeting*, vol. 3, July 2000, pp. 1548–1550.
- [29] I. Takahashi and M. Nunokawa, "Prediction control for a cycloconverter of a power distortion compensation system," *IEEE Trans. Ind. Applicat.*, vol. 25, pp. 348–355, Mar./Apr. 1989.
- [30] R. S. Weissbach, G. G. Karady, and R. G. Farmer, "Dynamic voltage compensation on distribution feeders using flywheel energy storage," *IEEE Trans. Power Delivery*, vol. 14, pp. 465–471, Apr. 1999.
- [31] B. Koch, "Flywheels challenge battery storage for ride-through of power interruptions," *Elec. World*, vol. 211, pp. 44–47, Dec. 1997.
- [32] H. Akagi, "Active filters and energy storage systems operated under nonperiodic conditions," in *Proc. 2000 IEEE Power Engineering Society Summer Meeting*, vol. 2, July 2000, pp. 965–970.
- [33] E. Haginomor, "EMTP simulation of transient stability enhancement phenomena by an inverter controlled flywheel generator," *Elec. Eng. Jpn.*, vol. 124, pp. 19–29, Aug. 1999.
- [34] Y. Mitani, K. Tsuji, and Y. Murakami, "Application of superconducting magnet energy storage to improve power system dynamic performance," *IEEE Trans. Power Systems*, vol. 3, pp. 1418–1425, Nov. 1988.
- [35] S. F. Kral, V. Karasik, Y. M. Lvovsky, K. E. Grut, J. P. Kelley, K. D. Dixon, P. F. Ribeiro, and R. Kunz, "Alaska SMES: Form and function for the world's largest magnet," presented at the 1997 Cryogenic Eng. Conf.
- [36] R. H. Lasseter and S. J. Jalali, "Dynamic response of power conditioning systems for superconductive magnetic energy storage," *IEEE Trans. Energy Conversion*, vol. 6, pp. 388–393, Sept. 1991.
- [37] —, "Dynamic response of power conditioning systems for superconductive magnetic energy storage," *IEEE Trans. Energy Conversion*, vol. 6, no. 3, pp. 388–393, Sept. 1991.
- [38] E. Haginomor, "EMTP simulation of transient stability enhancement phenomena by an inverter controlled flywheel generator," *Elec. Eng. Jpn.*, vol. 124, pp. 19–29, Aug. 1999.
- [39] J. D. Rogers, R. I. Schermer, B. L. Miller, and J. F. Hauer, "30-MJ superconducting magnetic energy storage system for electric utility transmission stabilization," *Proc. IEEE*, vol. 71, pp. 1099–1109, Sept. 1983.
- [40] M. Parizh, A. K. Kalafala, and R. Wilcox, "Superconducting magnetic energy storage for substation applications," *IEEE Trans. Appl. Superconduct.*, vol. 7, pp. 849–852, June 1997.
- [41] W. C. Tsai, C. Chyn, and T. P. Tsao, "Damping torsional oscillations due to network faults using the dynamic flywheel damper," in *IEE Proc. Generation, Transmission and Distribution*, vol. 144, Sept. 1997.
- [42] B. Szabodos and U. Schaible, "Peak power bi-directional transfer from high speed flywheel to electrical regulated bus voltage systems," *IEEE Trans. Energy Conversion*, vol. 13, pp. 34–41, Mar. 1998.
- [43] J. D. Rogers, R. I. Schermer, B. L. Miller, and J. F. Hauer, "30-MJ superconducting magnetic energy storage system for electric utility transmission stabilization," *Proc. IEEE*, vol. 71, pp. 1099–1109, Sept. 1983.
- [44] Y. Mitani, K. Tsuji, and Y. Murakami, "Application of superconducting magnet energy storage to improve power system dynamic performance," *IEEE Trans. Power Systems*, vol. 3, pp. 1418–1425, Nov. 1988.
- [45] K. K. Leung and D. Sutanto, "A storage power flow controller (SPFC) using battery storage," in *IEEE 1999 Int. Power Electronics and Drive Systems*, Hong Kong, July 1999.
- [46] W. R. Lachs and D. Sutanto, "Battery storage plant within large load centers," *IEEE Trans. Power Syst.*, vol. 7, pp. 762–769, May 1992.
- [47] L. Walker, "10-MW GTO converter for battery peaking service," *IEEE Trans. Ind. Applicat.*, vol. 26, pp. 63–72, Jan./Feb. 1990.
- [48] S. J. Chiang, C. M. Liaw, W. C. Chang, and W. Y. Chang, "Multi-module parallel small battery energy storage system," *IEEE Trans. Energy Conversion*, vol. 11, pp. 146–154, Mar. 1996.
- [49] C. Tarrant, "Revolutionary flywheel energy storage system for quality power," *Power Eng. J.*, vol. 13, pp. 159–63, June 1999.
- [50] B. Koch, "Flywheels challenge battery storage for ride-through of power interruptions," *Elec. World*, vol. 211, pp. 44–47, Dec. 1997.
- [51] R. S. Weissbach, G. G. Karady, and R. G. Farmer, "Dynamic voltage compensation on distribution feeders using flywheel energy storage," *IEEE Trans. Power Delivery*, vol. 14, pp. 465–71, Apr. 1999.
- [52] A. B. Arsoy, "Electromagnetic transient and dynamic modeling and simulation of a StatCom-SMES compensator in power systems," Ph. D. dissertation, Blacksburg, VA, 2000.
- [53] Z. Yang, M. L. Crow, C. Shen, L. Zhang, and P. Cao, "Steady-state characteristics of a StatCom with energy storage," in *Proc. 1999 North American Power Symp.*, San Luis Obispo, CA, Oct. 1999.
- [54] G. Asplund, K. Eriksson, H. Jiang, J. Lindberg, R. Palsson, and K. Svensson, "DC transmission based on voltage source converters," in *CIGRE Conf.*, Paris, France, 1998.
- [55] B. K. Johnson, R. H. Lasseter, and F. L. Alvarado, "Incorporation of a SMES coil into a superconducting LVDC transmission system," *IEEE Trans. Appl. Superconduct.*, pt. 1, vol. 7, pp. 419–422, June 1997.
- [56] B. K. Johnson and R. H. Lasseter, "An industrial power distribution system featuring UPS properties," in *1993 IEEE Power Electronics Specialists Conf. Rec.*, Seattle, WA, June 1993, pp. 759–765.
- [57] D. Lieurance, F. Kimball, C. Rix, and C. Luongo, "Design and cost studies for small scale superconducting magnetic energy storage systems," *IEEE Trans. Appl. Superconduct.*, vol. 5, pp. 350–353, June 1995.
- [58] S. M. Schoenung, W. R. Meier, R. L. Fagaly, M. Heiberger, R. B. Stephens, J. A. Leuer, and R. A. Guzman, "Design, performance, and cost characteristics of high temperature superconducting magnetic energy storage," *IEEE Trans. Energy Conversion*, vol. 8, pp. 33–38, Mar. 1993.
- [59] J. T. Alt, M. D. Anderson, and R. G. Jungst, "Assessment of utility side cost savings from battery energy storage," *IEEE Trans. Power Syst.*, vol. 12, pp. 1112–1120, Aug. 1997.
- [60] V. Karasik, K. Dixon, C. Weber, B. Batchelder, and P. Ribeiro, "SMES for power utility applications: A review of technical and cost considerations," *IEEE Trans. Appl. Superconduct.*, vol. 9, pp. 541–546, June 1999.
- [61] P. D. Baumann, "Energy conservation and environmental benefits that may be realized from superconducting magnetic energy storage," *IEEE Trans. Energy Conversion*, vol. 7, June 1992.
- [62] S. M. Schoenung, W. R. Meier, R. L. Fagaly, M. Heiberger, R. B. Stephens, J. A. Leuer, and R. A. Guzman, "Design, performance, and cost characteristics of high temperature superconducting magnetic energy storage," *IEEE Trans. Energy Conversion*, vol. 8, pp. 33–38, Mar. 1993.
- [63] S. M. Schoenung and C. Burns, "Utility energy storage applications studies," *IEEE Trans. Energy Conversion*, vol. 11, pp. 658–665, Mar. 1996.
- [64] J. D. Rogers, R. I. Schermer, B. L. Miller, and J. F. Hauer, "30-MJ superconducting magnetic energy storage system for electric utility transmission stabilization," *Proc. IEEE*, vol. 71, pp. 1099–1109, Sept. 1983.
- [65] Y. Mitani, K. Tsuji, and Y. Murakami, "Application of superconducting magnet energy storage to improve power system dynamic performance," *IEEE Trans. Power Syst.*, vol. 3, pp. 1418–1425, Nov. 1988.
- [66] S. Banerjee, J. K. Chatterjee, and S. C. Tripathy, "Application of magnetic energy storage unit as load-frequency stabilizer," *IEEE Trans. Energy Conversion*, vol. 5, pp. 46–51, Mar. 1990.

- [67] A. H. M. A. Rahim, A. M. Mohammad, and M. R. Khan, "Control of sub-synchronous resonant modes in a series compensated system through superconducting magnetic energy storage units," *IEEE Trans. Energy Conversion*, vol. 11, pp. 175–180, Mar. 1996.
- [68] S. F. Kral, V. Karasik, Y. M. Lvovsky, K. E. Grut, J. P. Kelley, K. D. Dixon, P. F. Ribeiro, and R. Kunz, "Alaska SMES: Form and function for the world's largest magnet," presented at the 1997 Cryogenic Engineering Conf..
- [69] M. Parizh, A. K. Kalafala, and R. Wilcox, "Superconducting magnetic energy storage for substation applications," *IEEE Trans. Appl. Superconduct.*, vol. 7, pp. 849–852, June 1997.
- [70] S. D. Feak, "Superconducting magnetic energy storage (SMES) utility application studies," *IEEE Trans. Power Syst.*, vol. 12, pp. 1094–1102, Aug. 1997.
- [71] M. Parizh, A. K. Kalafala, and R. Wilcox, "Superconducting magnetic energy storage for substation applications," *IEEE Trans. Appl. Superconduct.*, vol. 7, pp. 849–852, June 1997.
- [72] C. Rehtanz, "Systemic use of multifunctional SMES in electric power systems," *IEEE Trans. Power Syst.*, vol. 14, pp. 1422–1427, Nov. 1999.
- [73] J. J. Skiles, R. L. Kustom, K.-P. Ko, V. Vong, K.-S. Ko, F. Vong, and K. Klontz, "Performance of a power conversion system for superconducting magnetic energy storage," *IEEE Trans. Power Syst.*, vol. 11, pp. 1718–1723, Nov. 1996.
- [74] H. Shirahama, Y. Sakurai, Y. Matsuda, Y. Ishigaki, and K. Murai, "Instantaneous control method with GTO converter for active and reactive powers in superconducting magnetic energy storage," *IEEE Trans. Power Electron.*, vol. 9, pp. 1–6, Jan. 1994.
- [75] B. M. Han and G. G. Karady, "A new power-conditioning system for superconducting magnetic energy storage," *IEEE Trans. Energy Conversion*, vol. 8, pp. 214–220, June 1993.
- [76] R. H. Lasseter and S. J. Jalali, "Dynamic response of power conditioning system for superconducting magnetic energy storage," *IEEE Trans. Energy Conversion*, vol. 6, pp. 388–393, Sept. 1991.
- [77] R. L. Kustom, J. J. Skiles, J. Wang, K. Klontz, T. Ise, K. Ko, and F. Vong, "Research on power conditioning systems for superconductive magnetic energy storage (SMES)," *IEEE Trans. Magn.*, vol. 27, pp. 2320–2323, Mar. 1991.
- [78] T. Ise, Y. Murakami, and K. Tsuji, "Simultaneous active and reactive power control of superconducting magnet energy storage using GTO converter," *IEEE Trans. Power Delivery*, vol. PWRD-1, pp. 143–150, Jan. 1986.
- [79] S. M. Schoenung, W. R. Meier, R. L. Fagaly, M. Heiberger, R. B. Stephens, J. A. Leuer, and R. A. Guzman, "Design, performance, and cost characteristics of high temperature superconducting magnetic energy storage," *IEEE Trans. Energy Conversion*, vol. 8, pp. 33–38, Mar. 1993.
- [80] N. H. Woodley, L. Morgan, and A. Sundaram, "Experience with and inverter-based dynamic voltage restorer," *IEEE Trans. Power Delivery*, vol. 14, pp. 1181–1186, July 1999.
- [81] L. Weimers, "New markets need new technology," in *Powercon 2000 Conf.*, Dec. 2000.



**Paulo F. Ribeiro** (Senior Member, IEEE) received the B.S. degree in electrical engineering from the Universidade Federal de Pernambuco, Recife, Brazil, completed the Electric Power Systems Engineering Course with Power Technologies, Inc., and received the Ph.D. degree from the University of Manchester—UMIST, U.K.

Presently, he is a Professor of Electrical Engineering at Calvin College, Grand Rapids, MI, and a consultant engineer for BWX Technologies, Inc., Naval Nuclear Fuel Division. His research interests include power quality, power electronics (FACTS) interface with energy storage systems (superconducting energy storage systems).

Dr. Ribeiro is a member of CIGRE and is a Professional Engineer in Iowa.



**Brian K. Johnson** (Member, IEEE) received the Ph.D. degree in electrical engineering from the University of Wisconsin-Madison in 1992.

He is currently an Associate Professor in the Department of Electrical Engineering at the University of Idaho, Moscow, ID. His interests include HVDC transmission, FACTS, custom power technologies, energy storage, utility applications of superconductivity, power system protection, and electromagnetic transients in power systems.

Dr. Johnson is a member of CIGRE and is a Professional Engineer in Wisconsin and Idaho.



**Mariesa L. Crow** (Senior Member, IEEE) received the B.S.E degree in electrical engineering from the University of Michigan in 1985, and the M.S. and Ph.D. degrees in electrical engineering from the University of Illinois in 1986 and 1989, respectively.

She is presently a Professor of Electrical and Computer Engineering at the University of Missouri-Rolla. Her research interests have concentrated on developing computational methods for dynamic security assessment,

voltage stability, and the application of power electronics in bulk power systems.



**Aysen Arsoy** received the B.S. degree from Istanbul Technical University, Turkey, in 1992, the M.S. degree from the University of Missouri-Rolla in 1996, and the Ph.D. degree from Virginia Polytechnic Institute and State University in 2000, all in electrical engineering.

Her research interests include power electronics applications in power systems, computer methods in power system analysis, power system transients and protection, and deregulation.

Dr. Arsoy is a member of the IEEE Power En-

gineering Society.



**Yilu Liu** (Senior Member, IEEE) is an Associate Professor of Electrical Engineering at Virginia Polytechnic Institute and State University, Blacksburg, VA. Her current research interests are power system transients, power quality, power system equipment modeling, and diagnoses.

Dr. Liu is the recipient of the 1993 National Science Foundation Young Investigator Award and the 1994 Presidential Faculty Fellow Award.