

ENHANCING BUILDING SECURITY with RFID and ZIGBEE

Infanta.J^{#1}, Hemalatha.M^{*2}

[#]M.Tech-Embedded Systems, SASTRA University
Thanjavur, Tamil Nadu, India
infantajohn30@gmail.com

^{*}Assistant Professor, SASTRA University
Thanjavur, Tamil Nadu, India
hemalatha@it.sastra.edu

Abstract- ZigBee and RFID based monitoring, protection and security system is proposed in this paper. The smart node used in this system measures parameters like power, current, voltage and temperature. To prevent electrical fires and overloading, a threshold value is set at each outlet. The power and temperature parameters assessed by the smart node are transmitted to the base node through ZigBee. If the temperature exceeds or an overload occurs, a set of remote control instructions are executed in the PC. The base node instructs the smart node to cut off the power to the corresponding branch circuit. The entire operation can be monitored from a remote station. In this proposed system, RFID technique is added to provide a theft control mechanism. To prevent theft of valuables from an unauthorized person, RFID tags are used. RFID reader senses the RFID labels (master/slave tags) continuously and sends the information to a PC through ZigBee protocol. The database is checked in PC with the received information. If there is any mismatch in the RFID tags, it is considered to be an illegal input and a warning message is generated at the PC. The database is checked for the owner of that particular item and a confirming message is send to that owner. To search for that item the owner can login WEB. The valuable will be stopped by the entrance guard.

Keywords: ZigBee, RFID (Radio Frequency Identification), GSM (Global System for Mobile Communication), No Fuse Breakers (NFBs).

I. INTRODUCTION

Nowadays a lot of technologies are emerging in order to provide theft control mechanism. RFID is one of those techniques. RFID is Radio Frequency Identification and its concept is similar to traditional bar coding. RFID system is composed of RFID tags and RFID reader. RFID tags are attached with objects and RFID reader is used to gather information from relevant tags. There are certain advantages of RFID technique when compare to traditional bar coding. They are ability to perform two way communication, information density and non optical communication. RFID technique is used in lots of applications like toll collection, tracking library books, vehicle parking control, theft prevention etc [11].

There are many fire detection systems are available to provide warning regarding the occurrence of fire. This can be done by continuously monitoring the condition of the environment. This fire detection system may be actuated manually or automatically. There are lots of disadvantages in traditional fire detection system. In order to overcome these disadvantages CAN base system for fire detection was proposed. In conventional system actuators, detectors are connected to single analog signal line. In this system the receiver cannot identify the location in which fire occurred. This problem can be overcome by network based system for fire detection [18]. In order to know the power consumption, the outlet is made to be integrated with microcontroller. Switching operation can be done with the execution of instruction in microcontroller. Power management is needed to save energy. To improve the efficiency of this management, the equipments used in home must be made to obey controlling mechanism. Mobile phones with SMS service are used to have messages regarding condition of the home appliances. The user can control the appliances using this GSM technology. By using this system various executions can be done. For example, making the sockets to ON/OFF, to set the threshold value of alarm, set various values like password, user name etc [2].

There are lot of wireless protocols are available to provide communication among various devices. Among these protocols Bluetooth, ZigBee, Ultra wideband and Wi-Fi are used in various applications. Comparison among these protocols have been made based on following features like complexity, power consumption, data coding efficiency and transmission time [17]. Of these protocols ZigBee is used in various wireless sensor network applications. ZigBee network composed of three node types: sink node, routing node and terminal node. Sink nodes provide data and communication. Terminal and routing nodes correspond to actor nodes and sensor nodes. Sink node is made to be initialized first then the particular channel can be selected and

network will be established. Routing node will join or rejoin the wireless sensor network. Terminal node will join or rejoin the wireless sensor network and consider nearest sink or routing node as parent node [12].

II. RELATED WORK

Wireless sensor network contains large sensors which are deployed to form a network. There is no need to predetermine the position of the sensor nodes. It can be random deployed. Multi-hop communication is used to reduce the transmission power so that the lifetime of the battery is increased [1]. Lot of technologies have been emerged which are very much related to RFID technique. They are Identification Friend or Foe which is used in aircraft for long range transponder system in 1948, RFID techniques theoretical exploration in 1950s, prototype system and commercial system like sensormatic and checkpoint emerged in 1960s, in 1970s animal tagging became popular in order to get information regarding number of animals, tracking of animals became widespread in France, Portugal, Spain, Norway, Italy in 1980s, in United States electronic toll collection was adopted in 1990s. Many works have been undertaken to make development in this technology [11]. Improvement in new technology aims at decreasing cost to provide services and to increase the performance. RFID technology is used in various services. Generally there are several reasons to study the working of RFID technology. It includes time potential of it this technology, to use this technology in operation management, evolution of RFID at fast pace and to select particular configuration regarding the need of RFID [6]. RFID generally used in identification of objects. Unique electromagnetic signature is emitted by tag. These tags are attached with each object that can be captured by RFID reader and used for object tracking. Multi case approach is used to study RFID in order to use it in various applications [19]. RFID technology can be used if it satisfies one or more following conditions like reducing number of labors, reducing error in large custom work and to provide additional features. Applications like highway toll collection, cashless payment system in McDonald's, Distributed control in Beer Keg are consider in this study. 21 RFID cases are considered across various applications [6]. To provide security in campus a system is proposed which provide high reliability and flexibility. This system maintain database that contain fire information, building information, traffic information, security data etc [20]. RFID system consists of RFID tags, tag reader that contains transceiver and antenna and host system. RFID tags are divided into two one is tags with power supply and other one is tags without power supply. Tag data consist of unique identifier and also has data storage, operating system and electronic product code. Tags may be active or passive. Communication of active tags is through propagation coupling. Powers for passive tags are drawn from reader's transmission through inductive coupling [16]. The efficiency can be improved by using multiple RFID reader. The processing time can also be reduced [14]. RFID system provides various services like data management, control, device management etc. Base service set (BSS) can be used over the air. BSS is used in many ways eg., by external applications, by detecting tags, by timer [15]. The usage of RFID tags are under four categories. They are network system, portable data capture, positioning system and EAS (Electronic Article Surveillance). RFID technique has following advantages like no need of line of sight, non contact, can be used in various environmental conditions like fog, ice, snow etc. Security and privacy concerns of RFID technique falls under denial of service, technical attack, spoofing, customer information and location privacy [11]. Performance and scalability is affected by architecture of network in an RFID system. The architecture of Electronic Product Code (EPC) network depends on standard RFID system. RFID system composed of three elements. They are tag, RFID reader and Backend application system. The main advantage of RFID over bar coding is that it carries lots of information from tags. Savant is used to handle these data [8]. RFID technique is used in port management in order to withstand security threats. The model designed for this smart system have intelligence on expectation regarding arrival at port, information regarding what has been entered or entering the port, what is present in the port, what has leaving or left the port and illegal or legal transaction. There are some limitations in this system like every container should be tagged, environmental sensors should be attached inside the container for monitoring, and generation of alert is needed to identify violation. To overcome these limitations certain areas are needed to be researched. They are how to identify fake tag ID and need to improve standardization [9].

In wireless sensor network various protocols are used for communication. Bluetooth, ZigBee, Ultra Wideband (UWB) and Wi-Fi are some of the protocols used for communication in sensor network. For the purpose of replacing cables for peripheral devices in computer Bluetooth is used. Bluetooth is used in WPAN (Wireless Personal Area Network). Clock of master is used for synchronization in piconet. The transmission may be point to multipoint or point to point. Power saving modes is used to reduce power consumption. Used mainly in indoor short range communication. UWB has bandwidth of 110Mbps and above. So it satisfies video and audio delivery. It posses direct sequence multiple access (DS-UWB). ZigBee support simple devices which consumes less power. ZigBee supports mesh network. Reduced function device (RFD) and Full function device (FFD) are the two types of device types that participate in network. FFD act as PAN coordinator, device or coordinator. Only one coordinator will act as overall PAN coordinator that needs large computation resource. Wi-Fi meant for Wireless Fidelity used to access Internet through access point. Generally Wi-Fi used in WLAN. LAN includes fixed and mobile station. The spread spectrum of ZigBee, Bluetooth and Wi-Fi is in 2.4 GHz

which is unlicensed. Authentication and encryption mechanism is available in all four protocols. Transmission time of each protocol depends on its data rate. Based on primitive and events the protocol complexity is compared [17]. ZigBee network has four layers. They are physical layer, MAC layer, network layer and application layer. These layers are developed by ZigBee alliance. Physical layer uses hardware drivers to provide channel management and to realize transmission. MAC layer generally provide this following services data transmission service and data management service. Network layer provide data services and management services. Application layer provide programming interfaces to developers in order to develop corresponding function [12].

GSM technology has been widely used in various applications. This technology has been used by public to have SMS applications, roaming, quality of voice etc. Nowadays GPRS (General Purpose Radio Service) has been introduced in existing GSM technology to have efficient usage of internet applications [3], [5]. Reasons for the fires may be overloading, aging, current leakage in power distribution system else due to external fire. To reduce the possibility of fires various systems have been proposed like fire detection system with alarm [4].

Electrical safety is very much needed in large buildings. Traditional fire detection system has several disadvantages. This system cannot produce required data like level of heat, amount of smoke etc. But network based system overcome these disadvantages. Here the detector, bell, actuator are all connected in shared medium. So that information can be exchanged. Relevant data can be received. Identify location where fire occurs. CAN 2.0B has following properties like access of medium in distributed manner, provide error detection using cyclic redundancy check and each packet of message has unique identifier [18]. Home automation network can be implemented using ZigBee protocol. This system used to control power outlet of the system. In order to have remote control function wires are needed which is not a feasible solution. This may destroy interior decoration of house. So this system is proposed by using ZigBee. Power outlet is the main component. It is composed of ZigBee, power transformer, main board and base [7]. By using ZigBee protocol the electricity data is collected to provide relevant details to user. So that the user can control the appliances used in home. As a result energy will be saved [13]. Security mechanism in buildings regarding power consumption is very much important and basis for building a secured system. In ZigBee based security system data transmission is done through ZigBee protocol. Smart node used in this system measure temperature and power parameters. Transfer this information via ZigBee to base node. Depending on threshold value control operation can be executed by remote station results in ON/OFF in each branch circuit. So that electrical fires can be avoided [10].

III. SYSTEM OVERVIEW

The overall structure of this proposed system is shown in figure 1. The smart node measures temperature and power parameters from each outlet of the branch circuit. These measured values are transmitted to the base node through ZigBee protocol. On receiving these values the base node set threshold value to each branch circuit. When the temperature exceeds the threshold value means the smart node is instructed to cut the power in order to avoid electrical fires. And also when the power exceeds the threshold value the power is cut off by the smart node to avoid overloading.

Additionally base node contains RFID reader to provide theft control mechanism. RFID tags can be attached in valuables like laptops, mobiles, iPad, PDA's etc. Each one of the tags has unique ID. The owner of the item will be provided with master tag and many slave tags which will be attached in their valuables. RFID reader continuously senses these tags and sends information to PC. PC then checks the database. If master and slave tag match or only master tag appears, then the input is legal. If master and slave tag mismatch or only slave tag appears, then the input is illegal and generate warning message at PC. PC then checks for owner of that item and send warning message using GSM. Finally after confirmation the valuables will be stopped.

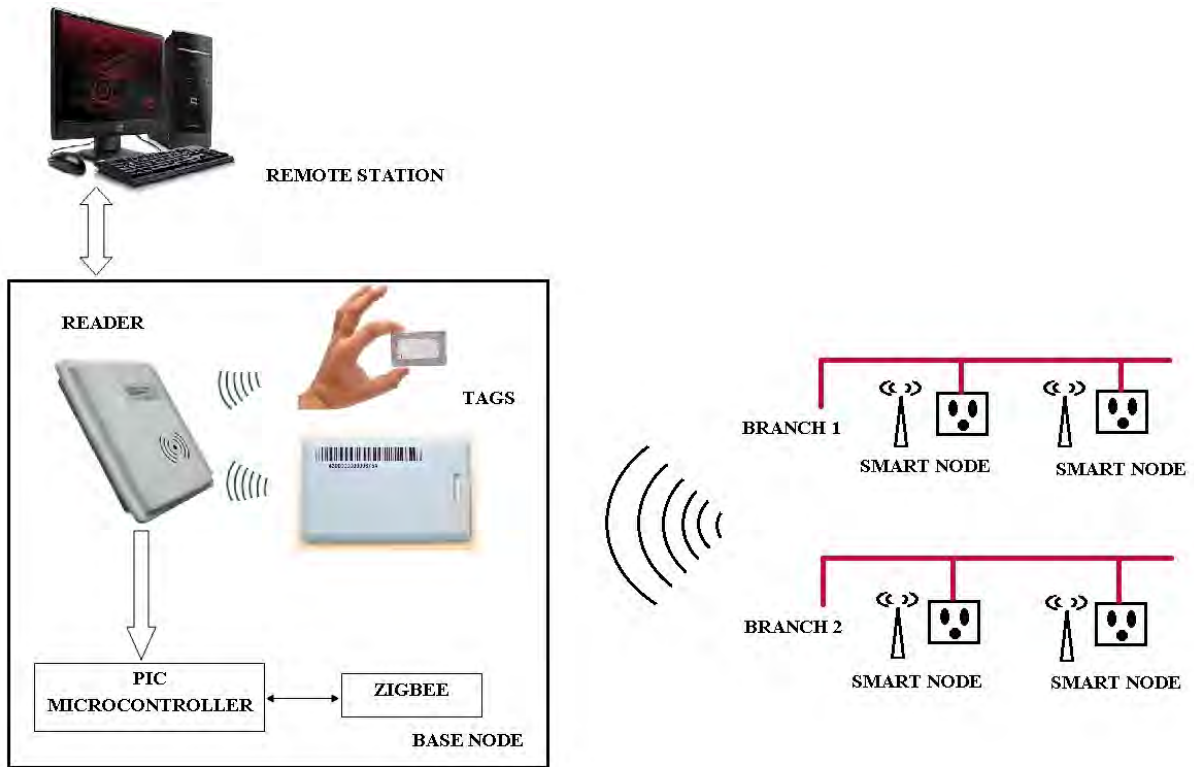

Fig. 1. Overview of the system

IV. SYSTEM IMPLEMENTATION

A. Base node

The base node consists of PIC microcontroller (PIC16F877a), RFID Reader, GSM module, Zigbee module, LCD module and alarm. The schematic diagram of base node is shown in figure 2.

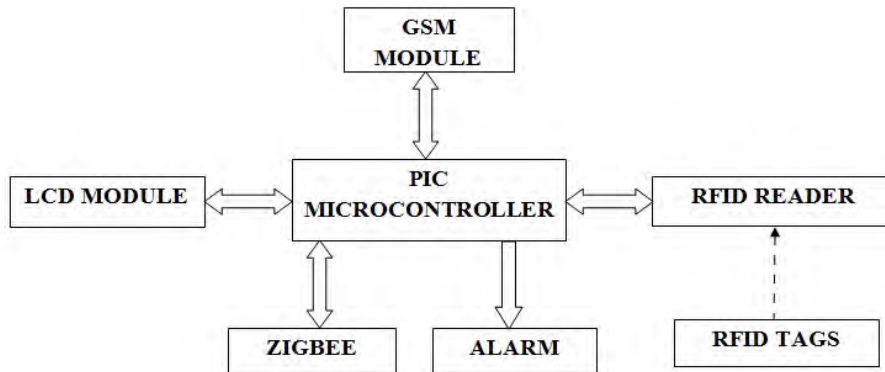

Fig. 2. Schematic diagram of base node

The controlling centre of this proposed system is the base node. All the information collected by the base node is transmitted to PC. The flow chart of base node is shown in figure 3. Controller is responsible for entire control of the system. PIC is generally referred to Peripheral Interface Controller. It has inbuilt ADC. PICs are used in various applications due to following features like wide availability, reprogramming capability, low cost etc. PIC belongs to Harvard architecture.

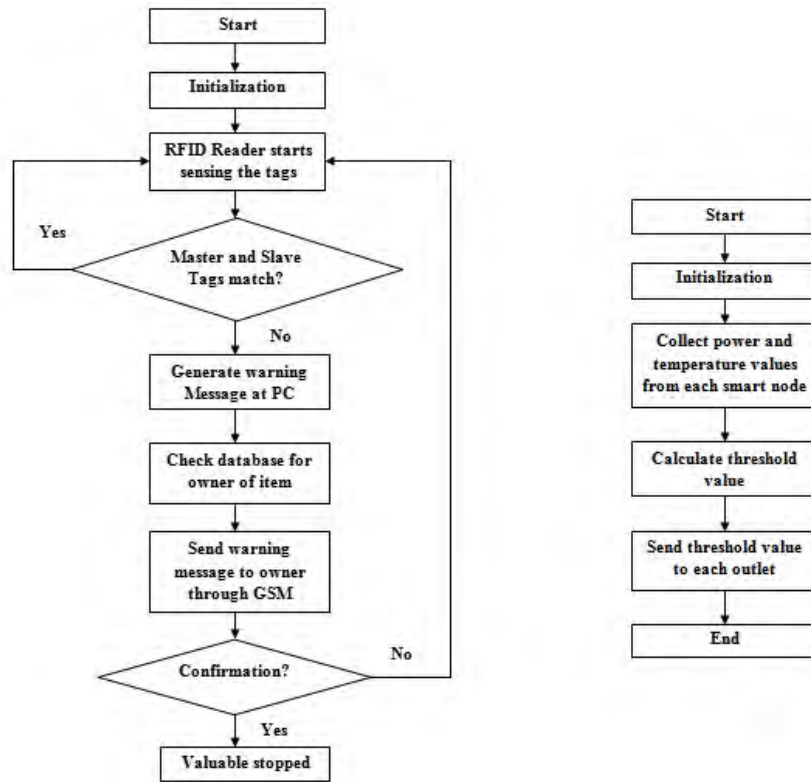

Fig. 3. Flow chart of base node: a) RFID operation
b) Temperature and power measurement

1) *RFID Reader*: RFID interrogate with RFID tag and collect required information. RF wave are used by the RFID reader for communication. It performs both transmission and reception. RFID reader can be in fixed position or mobile. RFID readers are available as module, printers, label applicators etc. RFID reader has error detection and CRC generation internally. It is compatible with transponders, tags and complaint cards. Operates at +5v DC supply. It can accommodate temperature ranging from -40° C to +85°C. RFID reader module is shown in figure 4.



Fig. 4. RFID Reader module

The RFID reader senses the RFID tags. Each tag has unique ID and the reader collects this unique address from each tag. Then the information is transmitted to microcontroller for further processing. Through ZigBee protocol the processed data is transmitted to PC. The schematic diagram of RFID security system is shown in figure 5.

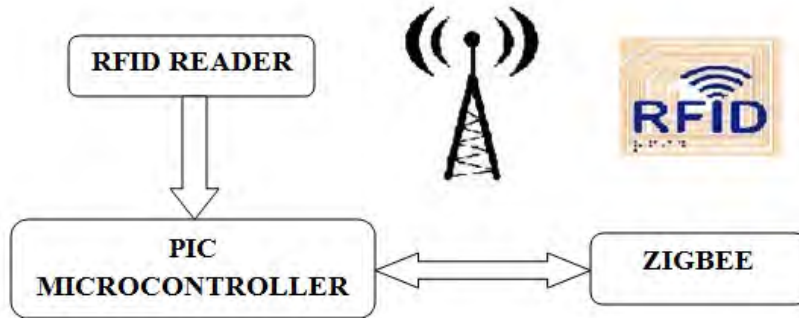

Fig. 5. RFID security system

2) *ZigBee Module*: ZigBee is a communication protocol used in several low power devices. It is based on IEEE 802.15.4 standard. The name ZigBee came from honeybee that follows zigzag movement to communicate with other members. This is the basic ZigBee principle. The data rate of ZigBee protocol is 250 Kb/s. IEEE 802.15.4 support peer to peer or star topology. It can be combined to form mesh networks. ZigBee protocols radio frequency is 2.4 GHz.

3) *GSM Module*: GSM stands for Global System for Mobile Communication. GSM networks have several sections like network and switching subsystem, base station subsystem, GPRS network, operating support system. GSM modem accepts SIM card from GSM network operator and just act like general mobile phone. It can be connected directly to PC or any microcontroller. GSM modem can be used in various applications like data transfer, SMS control, network control etc. In this proposed system GSM modem is used to send warning message to the owner. GSM modem-SIM 300 is shown in figure 6.



Fig. 6. GSM modem-SIM 300

16x2 LCD is used in this proposed system. It is used to display temperature and power parameters. Alarm is set to indicate abnormal condition caused due to overload, high temperature or any mismatch between master and slave tags.

B. Smart node

Smart node consist of PIC microcontroller, power measurement module, temperature module, zigbee module, LED, relay and driver circuit (control module). The schematic diagram of smart node is shown in figure 7.

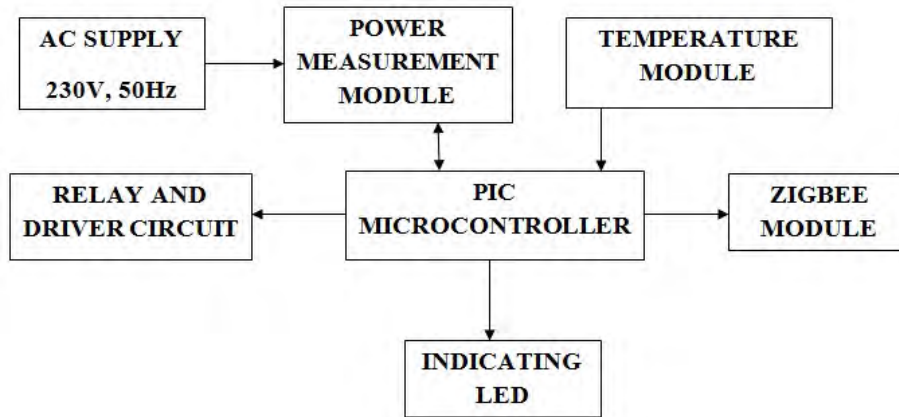

Fig. 7. Schematic diagram of smart node

Smart node collects temperature and power parameters from each outlet of the branch circuit. The flow chart of smart node is shown in figure 8.

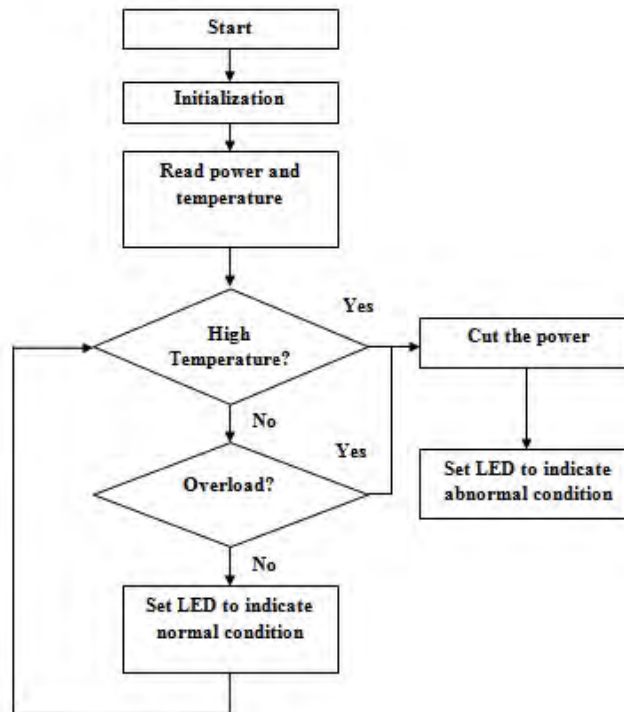

Fig. 8. Flow chart of smart node

LM35 is the temperature sensor used in this system. It measures the temperature from outlet. Temperature module is used to prevent electrical fires. LM35 calibrate the value in °Celsius. Its guaranteed accuracy is 0.5 °C. It is of low cost and used in various remote applications. Structure of LM35 sensor is shown in figure 9.

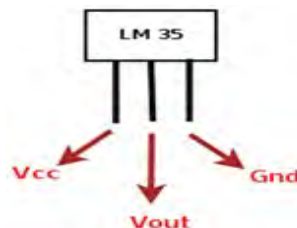

Fig. 9. Structure of LM35 sensor

This relay and driver circuit constitutes to form control module. Relay status depends on control instruction from microcontroller. The switching ON/OFF operation in relay used to control the power at the outlet. LEDs are used to indicate the condition of the system. Green LED used to indicate normal condition and Red LED used to indicate abnormal condition.

V. CONCLUSION AND FUTURE WORK

This proposed system is very cost effective and it overcomes the limitations present in traditional fire detection system. It provides prevention from electrical fires which cause huge disaster. This system also provides theft control mechanism using RFID technique. This system can be used in colleges, schools, offices etc. RFID technique gives solution to theft control and used in tracking of unauthorized valuables. If this system is used in schools/colleges, this RFID tags (master/slave) can be used to take attendance of students, for taking books from libraries, for paying fees the tag information can be used as reference.

ACKNOWLEDGMENT

The authors wish to thank SASTRA University for providing financial support for this research work under the Research and Modernization fund– R&M/0008/SOC – 001/2009-10.

References

- [1] I.F. Akyildiz, W. Su, Y. Sankarasubramaniam and E. Cayirci, “*Wireless sensor networks: a survey*”, Computer Networks, Vol-38, 2002, pg: 393-422.
- [2] Chia-Hung Lien, Ying-Wen Bai, and Ming-Bo Lin, “*Remote-Controllable Power Outlet System for Home Power Management*”, IEEE Transactions on Consumer Electronics, Vol. 53, 2007, No. 4, pg: 1634-1641.
- [3] Chwan-Lu Tseng, Joe-Air Jiang, Ren Guey Lee, Fu-Ming Lu, Cheng-Shiou Ouyang, Yih-Shaing Chen, Chih-Hsiang Chang, “*Feasibility study on application of GSM–SMS technology to field data acquisition*”, Computers and Electronics in Agriculture, August 2006, Vol-53, pg: 45-49.
- [4] DING Hong-jun, LIU Xiao-lu, “*Several Ideas on Fire Detecting Alarm for Power Supply and Distribution System*”, Procedia Engineering, 2011, Vol-11, pg: 75-79.
- [5] M. Ermel, T. Muller, J. Schuler, M. Schweigel, K. Begain, “*RFID Technology and Zigbee Networking in Improving Supply Chain Traceability*”, IEEE, May 2002, Vol-48, pg: 285-310.
- [6] Geraldo Ferrer, Nicholas Dew, Uday Apte, “*When is RFID right for your service?*”, Int. J. Production Economics, Vol-124, April 2010, pg: 414-425.
- [7] Guangming Song, Fei Ding, Weijuan Zhang and Aiguo Song, “*A Wireless Power Outlet System for Smart Homes*”, IEEE Transactions on Consumer Electronics, Vol-54, No. 4, November 2008, pg: 1688-1691.
- [8] Jiann-Liang Chen, Ming-Chiao Chen, Chien-Wu Chen, Yao-Chung Chang, “*Architecture design and performance evaluation of RFID object tracking systems*”, Computer Communications, Vol-30, 30 June 2007, pg: 2070-2086.
- [9] Joseph K. Siror, Sheng Huanye, Wang Dong, “*RFID based model for an intelligent port*”, Computers in Industry, Vol-62, October-December, 2011, pg: 795-810.
- [10] Li-Chien Huang, Hong-Chan Chang, Cheng-Chung Chen, Cheng-Chien Kuo, “*A ZigBee-based monitoring and protection system for building electrical safety*”, Energy and Buildings, Vol-43, June 2011, pg: 1418-1426.
- [11] C.M. Roberts, “*Radio frequency identification (RFID)*”, computers and security, Vol-25, February 2006, pg: 18-26.
- [12] Tao Tao, Tong Zhong-hua, Zhang Hui-yi, “*Depth Analysis of ZigBee Protocol on Wireless Sensor-actuator Network*”, Energy Procedia, Vol-13, December 2011, pg: 2267-2274.
- [13] Woong Hee Kim, Sunyoung Lee, Jongwoon Hwang, “*Real-time Energy Monitoring and Controlling System based on ZigBee Sensor Networks*”, Procedia Computer Science, 2011, Vol-5, pg: 794-797.
- [14] Chen Qian, Hoilun Ngan and Yunhao Liu, “*Cardinality Estimation for Large-scale RFID Systems*”, IEEE, 2011, Vol-22, pg: 1441-1454.
- [15] Christian Floerkemeier and Sanjay Sarma, “*An Overview of RFID System Interfaces and Reader Protocols*”, IEEE, 2008, pg: 232-240.
- [16] A. Elshayeb, Khalid Bin Hasnan and Chua Yik Yen, “*RFID Technology and Zigbee Networking in Improving Supply Chain Traceability*”, IEEE, November 2009, Vol-5, pg: 1-3.
- [17] Jin-Shyan Lee, Yu-Wei Su, and Chung-Chou Shen, “*A Comparative Study of Wireless protocols: Bluetooth, UWB, ZigBee, and Wi-Fi*”, IEEE Industrial Electronics Society (IECON), November 2007, pg: 46-51.
- [18] Kyung Chang Lee, Hong-Hee Lee, “*Network-based Fire-Detection System via Controller Area Network for Smart Home Automation*”, IEEE Transactions on Consumer Electronics, Vol-50, No. 4, November 2004, pg: 1093-1100.
- [19] Ying Chen, Yuntao Wang, Xiaokang Li, Li Gao, “*The Design and Implementation of Intelligent Campus Security Tracking System Based on RFID and ZigBee*”, IEEE, July 2011, pg: 1749-1752.
- [20] Zhu Yuan-jiao, Zhou Ke-qin, “*Design and Realizing of the Digital Campus Security System*”, IEEE, 2008, Vol- 4, pg: 305-309.