

# Enzyme Redundancy and the Importance of 2-Oxoglutarate in Higher Plant Ammonium Assimilation

Muriel Lancien, Pierre Gadal, and Michael Hodges\*

Department of Biology, New York University, New York, New York 10003 (M.L.); and Institut de Biotechnologie des Plantes, Centre National de la Recherche Scientifique, Unité Mixte de Recherche 8618, Bâtiment 630, Université Paris Sud, 91405 Orsay cedex, France (P.G., M.H.)

The assimilation of inorganic N, in the form of ammonia, onto C skeletons for the production of amino acids is one of the most important biochemical processes in plants. In an actively growing plant, N is taken up as nitrate and to a lesser extent as ammonia. Nitrate is reduced in the cytoplasm by nitrate reductase and nitrite enters the chloroplasts where it is further reduced before incorporation into amino acids. In addition to this steady influx of N, there is recycling of N compounds that also produces ammonia that needs to be assimilated. This recycling results from the operation of the photorespiratory cycle with the oxidation of Gly in the mitochondria (Fig. 1), the breakdown of storage proteins in seeds, leaf, and bark tissues, and the breakdown of proteins and nucleic acids associated with cellular senescence and apoptotic phenomena.

Some plants, especially the leguminous plants, are able to convert atmospheric dinitrogen into ammonia in their symbiotic root nodules and this ammonia is rapidly assimilated into nitrogenous compounds for export out of the nodules. Because ammonia is toxic it needs to be rapidly assimilated, and in all of these processes, assimilation is carried out by the concerted action of two enzymes: Gln synthetase (GS) and Glu synthase (GOGAT) (Table I; Ireland and Lea, 1999). For the GS/GOGAT cycle to work, N metabolism must interact with C metabolism, since GS activity requires energy in the form of ATP and the GOGAT uses C skeletons and reductant in the form of 2-oxoglutarate (2OG) and reduced ferredoxin or NADH, respectively. This pathway is of crucial importance, since the Gln and Glu produced are donors for the biosynthesis of major N-containing compounds, including amino acids, nucleotides, chlorophylls, polyamines, and alkaloids (Lea and Ireland, 1999).

Although many biochemical studies have improved our understanding of plant N metabolism, the exact enzymes involved and the factors controlling this process are still often lacking. Many enzymes involved in ammonium assimilation are found as multiple enzyme/isoenzyme forms that are often located in distinct subcellular compartments or within different

organs and tissues. Whether these enzymes play overlapping (redundant) or distinct (non-redundant) roles is an important question. Recent data have begun to shed some light on this problem. This is relevant for different GS/GOGAT cycle enzymes but also when considering the enzymes producing 2OG, the major organic acid located at the interface between C and N metabolisms and essential for Glu synthesis. This key C compound is mainly derived from sugar respiration and amino acid transamination reactions and its production can be brought about by a number of different enzymes such as isocitrate dehydrogenases, aminotransaminases, and Glu dehydrogenases (GDHs; Table I).

This *Update* gives a review of our current knowledge concerning the enzymes involved in plant ammonium assimilation and 2OG production for primary amino acid synthesis. It highlights the fact that the intermingling of C and N metabolisms is complex, involves the presence of several isoenzyme families, and the integrated functioning of both cytosolic and organelle-associated enzymes. Studies involving molecular genetics and plant engineering have produced much of the recent data presented in this *Update* that argue in favor of specific non-redundant roles for different enzymes. Furthermore, over the years, it has become evident that plant C and N metabolism are tightly coordinated and that certain signaling molecules like hormones and key C and N metabolites play an important role. Since 2OG levels can reflect C/N status within the cell, this metabolite could be involved in the monitoring and signaling of C/N balance to the plant regulatory machinery, and emerging evidence for this role will be discussed.

## AMMONIUM ASSIMILATION, THE GS/GOGAT CYCLE, AND GDH

### GS

GS carries out the first step in inorganic N incorporation into amino acids by transferring ammonium to Glu to form Gln (Table I). Plants contain two types of GS, named GS1 and GS2, which have been located to the cytosol and plastids, respectively. In all plants studied, GS2 is encoded by a single gene, whereas GS1 belongs to a small gene family. Distinct roles for

\* Corresponding author; e-mail [hodges@ibp.u-psud.fr](mailto:hodges@ibp.u-psud.fr); fax 33-1-69-33-64-23.

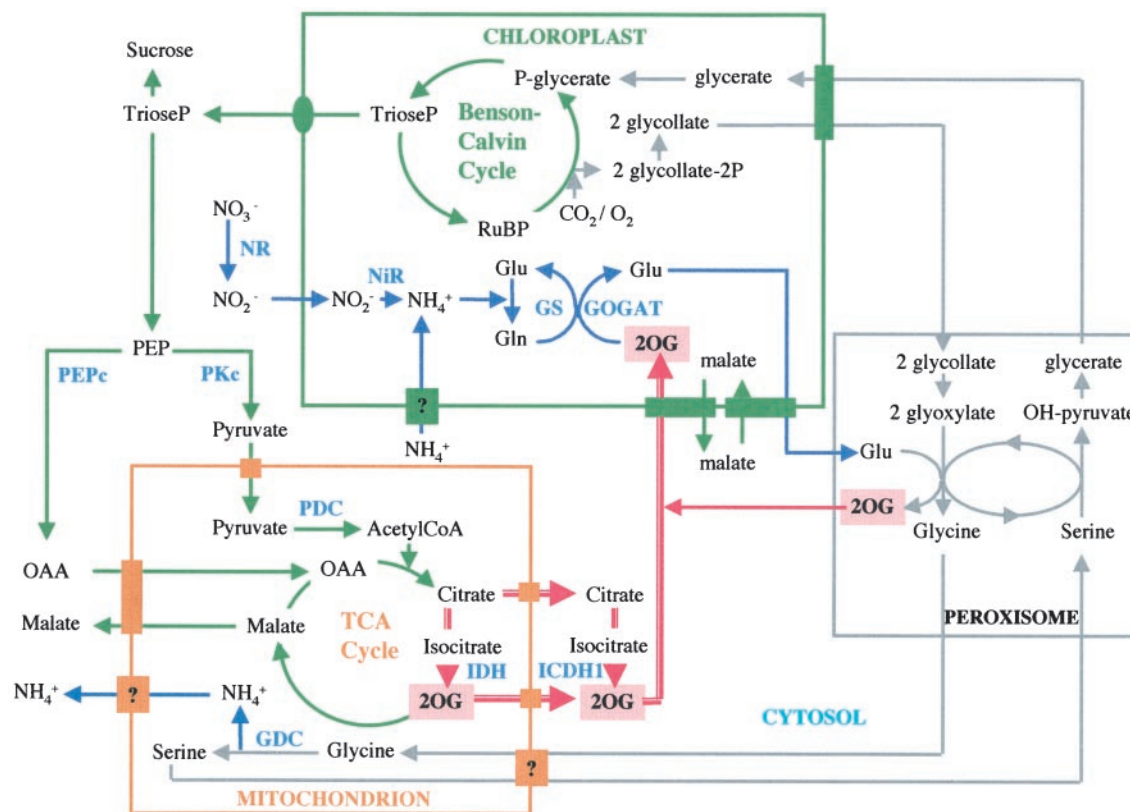

**Figure 1.** A simplified scheme showing C and N flow between organelles and the possible involvement of isocitrate dehydrogenases in 2OG production for ammonium assimilation. In higher plant leaves, ammonium is assimilated in the chloroplasts by the action of the GS/GOGAT pathway. Ammonium is directly formed in the chloroplast from cytosolic nitrate reductase (NR)-derived nitrite by a nitrite reductase (NIR) activity or in the mitochondria during photorespiration via the GDC. For net Glu production, the GOGAT requires C skeletons in the form of 2OG. Two pathways involving isocitrate dehydrogenases have been proposed. In one pathway 2OG, synthesized in the mitochondria by the IDH, is exported to the cytosol via a 2OG transporter. In the second pathway, citrate is exported from the mitochondria to the cytosol and metabolized to 2OG by the sequential action of an aconitase and the cytosolic ICDH (ICDH1). In both cases, 2OG is transported from the cytosol to the chloroplast by a 2OG/malate translocator. Photorespiratory ammonium re-assimilation by the chloroplastic GS/GOGAT cycle is coupled to peroxisome metabolism via the cycling of Glu and 2OG between these two organelles. This metabolite shuttling is controlled by a double translocator system composed of chloroplastic 2OG and Glu translocators. A malate-OAA shuttle is important in the maintenance of low mitochondrial NADH levels and the transfer of reducing equivalents to the peroxisome for glycerate synthesis from hydroxy-pyruvate (OH-pyruvate) during photorespiration. See the text for abbreviations; RuBP, Ribulose 1,5-bisphosphate.

these two enzymes have been suggested from a number of organ, tissue, and developmental studies. In most plant leaves, GS2 is the major GS isoform being located to mesophyll cell chloroplasts. GS1 is present mainly in non-green tissues such as seeds, roots, flowers, and nodules but also in the phloem companion cells of leaves. In *Arabidopsis* leaves, GS2 expression depends upon light in a phytochrome- and sugar-dependent manner (Oliveira and Coruzzi, 1999). The characterization of GS2 mutants has shown that this isoenzyme is indispensable in the reassimilation of the large quantities of ammonium released from the photorespiratory N cycle (Fig. 1; Ireland and Lea, 1999). The inability of GS1 to replace GS2 function under photorespiratory conditions is taken as evidence that the cytosolic form has a distinct role to play in green leaf tissues. GS1 is probably

involved in the remobilization of N compounds, since its expression is induced during senescence (Buchanan-Wollaston and Ainsworth, 1997), whereas transgenic birdsfoot trefoil (*Lotus corniculatus*) over-expressing a soybean GS1 gene exhibit early senescence symptoms due to an accelerated N remobilization (Vincent et al., 1997). However, the reduction of *Gln1-5* (a cytosolic GS) expression in tobacco leaf phloem only led to a reduction in Pro content, whereas other transportable amino acids were unaffected. Interestingly, these plants were more susceptible to salt stress (Brugière et al., 1999). GS1 is also important in legume plant root nodules, where it is involved in the assimilation of ammonium produced from bacterial N fixation (Temple et al., 1998).

Therefore, a clear picture is now emerging for the non-redundant roles of GS isoenzymes in plant func-

**Table I.** Enzymes, sub-cellular localization, and enzymatic activities involved in primary amino acid synthesis in higher plant cells

Enzyme	Localization	Enzymatic Activity
GS	Cytosol (GS1), plastid (GS2)	L-Glu + ATP + NH <sub>4</sub> <sup>+</sup> → L-Gln + ADP + P <sub>i</sub> + H <sub>2</sub> O
GOGAT	Plastid	2OG + L-Gln + NADH or Fd <sub>red</sub> → 2 L-Glu + NAD or Fd <sub>ox</sub>
GDH	Mitochondria (NAD-GDH), plastid (NADP-GDH)	Glu + NAD(P) + H <sub>2</sub> O ↔ 2OG + NH <sub>4</sub> <sup>+</sup> + NAD(P)H
ICDH	Cytosol, mitochondria plastid, peroxisome	L-Isocitrate + NAD $\xrightarrow{\text{Mg}^{2+}/\text{Mn}^{2+}}$ 2OG + NADPH + CO <sub>2</sub>
IDH	Mitochondria	L-Isocitrate + NAD $\xrightarrow{\text{Mg}^{2+}/\text{Mn}^{2+}}$ 2OG + NADH + CO <sub>2</sub>
Asp aminotransferase (AspAT)	Cytosol, mitochondria plastid, peroxisome	L-Glu + OAA ↔ L-Asp + 2OG

tion (Table II). GS2 has an exclusive role in ammonium assimilation from photorespiration and primary leaf nitrate assimilation. GS1 is associated with ammonium assimilation in legume nodules and, perhaps, in the roots of certain plant species as well as N-compound remobilization (germination and senescence) and Pro synthesis.

#### Ferredoxin- and NADPH-Dependent GOGATs

GOGAT carries out the second step in the GS/GOGAT cycle, catalyzing the reductant-dependent conversion of Gln and 2OG to two molecules of Glu (Table I). Two different forms of GOGAT, both located to plastids, exist in higher plants that differ in electron donor specificity: ferredoxin-dependent (Fd-GOGAT) and NADH-dependent (NADH-GOGAT) enzymes (Table I). In leaves and roots, the predominant enzyme is Fd-GOGAT. It is important in leaf photorespiratory ammonium assimilation since Fd-GOGAT (*gls*) mutants containing 5% or less GOGAT activity show severe stress symptoms when grown in air (Ireland and Lea, 1999). Recently, two Fd-GOGAT genes, *GLU1* and *GLU2*, have been isolated from *Arabidopsis* (Coschigano et al., 1998). *GLU1* expression is low in root tissues and most abundant in leaves where it is stimulated by light and by Suc in the dark. Chromosome mapping has revealed that the *gls* mutant allele corresponds to *GLU1* (Coschi-

gano et al., 1998). These observations are consistent with a role for the *GLU1* gene product in leaf primary N assimilation. On the other hand, *GLU2* expression is constitutive, relatively low in leaves, higher in roots, and not susceptible to Suc induction (Coschigano et al., 1998). Such characteristics explain the inability of *GLU2* to replace *GLU1* function in leaves and indicate distinct roles for these Fd-GOGAT isoenzymes (Table II).

NADH-GOGAT activity is 2- to 25-fold lower than that of Fd-GOGAT, being found mainly in non-green tissues like seeds and roots. Since it has a pronounced tissue-specific expression and it is unable to replace *GLU1* in *gls* mutants, NADH-GOGAT is expected to carry out distinct metabolic functions (Table II). A putative role for NADH-GOGAT in Gln export to the phloem in senescing tissues and roots reflects its expression in vascular tissue cells of roots and developing leaves as well as in root epi- and exodermis cells of rice (Hayakawa et al., 1999). Since, in roots, NADH-GOGAT expression is stimulated by low levels of ammonium (Hirose et al., 1997) and by nitrate addition after N starvation (Lancien et al., 1999), a role in primary N assimilation in this organ is possible. Indisputably, an important role for NADH-GOGAT is in ammonium assimilation in legume nodules where its expression is developmentally regulated in response to functional N-fixing nodules (Temple et al., 1998).

**Table II.** Enzymes involved in specific processes associated with ammonium assimilation in plants

*GLU1*, *GLU2*, *ASP2*, and *GDH1* are *Arabidopsis* genes. *AAT2* is an alfalfa gene.

Metabolic Process	Organ/Tissue	Enzymes Involved	
		Known	Proposed
Photorespiratory ammonium assimilation	Leaf mesophyll cells	GS2, Fd-GOGAT ( <i>GLU1</i> )	IDH, ICDH1, AspAT
Nitrate-derived ammonium assimilation	Leaves	GS2, Fd-GOGAT ( <i>GLU1</i> )	ICDH1, IDH, AspAT
	Roots	GS1, Fd-GOGAT ( <i>GLU2</i> ) NADH-GOGAT	ICDH1, IDH, AspAT
Symbiotic ammonium assimilation	Nodules	GS1, NADH-GOGAT, AspAT ( <i>AAT2</i> )	
Remobilization of N compounds	Leaves	GS1, NADH-GOGAT, AspAT ( <i>ASP2</i> )	ICDH1
	Roots	GS1, NADH-GOGAT	ICDH1
Senescence	Leaves	GS1, NADH-GOGAT, NADH-GDH	ICDH1
Germination	Seeds	GS1, NADH-GOGAT, NADH-GDH	ICDH1
Ammonium detoxification		NADH-GDH ( <i>GDH1</i> )	
Pro synthesis/water stress	Leaf phloem cells	GS1	

### The Role of GDHs Could Be Limited to Special Conditions

GDHs catalyze a reversible enzymatic reaction involving the assimilation of ammonium into Glu and the deamination of Glu into 2OG and ammonium. Two types of GDH exist depending on the cofactor used; either NAD(H) or NADP(H) for the mitochondrial and chloroplastic forms, respectively (Table I). Most data concern NADH-GDH, although its precise physiological role remains to be elucidated. Two *Arabidopsis* NADH-GDH genes, *GDH1* and *GDH2*, have been isolated that respond differentially to C/N status (Suc, nitrate, and ammonium) in different organs, suggesting specific roles (Melo-Oliveira et al., 1996). *GDH1* transcripts are not detected in the roots, whereas in leaves, *GDH1* is highly expressed in the dark but light and Suc addition reduce its expression. The addition of ammonium to light-grown leaves increased *GDH1* expression. It has been suggested that in vivo NADH-GDH activity could be limited to special conditions such as dark stress, natural senescence, and fruit ripening (Table II). A role in ammonium detoxification would explain the increase in GDH expression under conditions that provoke high ammonium levels and the retarded seedling growth phenotype and chlorosis of an *Arabidopsis* *gdh1-1* mutant grown on excess inorganic N (Melo-Oliveira et al., 1996).

Although an assimilatory function has been suggested for NAD-GDH under N stress growth conditions, it is probable that it has a catabolic role during seed germination, senescence, and other C-limiting conditions where 2OG would be used to replenish the tricarboxylic acid (TCA) cycle and not for N assimilation. This anapleurotic function is supported by studies using carrot cell cultures under C and energy limiting growth conditions (Robinson et al., 1992). Therefore, the direction of the GDH enzymatic reaction would depend on N and C source; ammonium, Gln, or sugars favoring the biosynthetic amination reaction (production of Glu) and nitrate, Glu, or C limitation favoring the catabolic de-amination reaction (production of 2OG). Interestingly, transgenic tobacco expressing *Escherichia coli* *GDH<sub>a</sub>* showed a 10% to 30% increase in plant yield and N-use efficiency under field conditions (Long and Lightfoot, 1996). The economic importance of this observation is shown by U.S. patent no. 587994 concerning the polypeptides and polynucleotides relating to the  $\alpha$ - and  $\beta$ -subunits of a GDH and methods of use in improving plant yield.

### ISOCITRATE DEHYDROGENASES AND Asp AMINOTRANSFERASES CAN SYNTHESIZE THE 2OG REQUIRED FOR GOGAT ACTIVITY

#### Isocitrate Dehydrogenases Allow for Net Glu Synthesis

Isocitrate dehydrogenases produce 2OG from isocitrate and require a pyridine nucleotide as cofactor.

Plants actually have two types of isocitrate dehydrogenase that use different cofactors; one is dependent upon NAD (IDH) and the other uses NADP (ICDH) (Table I). IDH is a TCA cycle enzyme, located uniquely in the mitochondria of eukaryotic cells. Distinct ICDH isoenzymes are located within the cytosol (ICDH1), mitochondria, plastids, and peroxisomes and their precise physiological function(s) are unknown (Gálvez et al., 1999). The synthesis of 2OG as a substrate for GOGAT activity by an isocitrate dehydrogenase leads to direct net Glu synthesis (Fig. 2). Two hypotheses involving different isocitrate dehydrogenases and subcellular compartments are described for GS/GOGAT functioning.

Although GOGAT is an enzyme uniquely located in the plastids, it has been proposed that mitochondria are the source of the 2OG required for GOGAT activity. In this hypothesis, 2OG produced by the IDH would leave the TCA cycle and the mitochondria to be imported into the plastids (Fig. 1). Surprisingly, little is known about this enzyme as its low in vitro activity and high instability have hampered progress in our understanding of plant IDH function and regulation. Recently an IDH has been purified to homogeneity from *Chlamydomonas reinhardtii*, a unicellular green alga (Martínez-Rivas and Vega, 1998). In plants, only partially purified IDH has been characterized. Etiolated pea plants show two biochemically distinct forms associated with the mitochondrial soluble matrix and membrane fractions (McIntosh, 1997). These IDH forms show similar enzymatic properties and, like all TCA cycle dehydrogenases, are inhibited by NADH. It was suggested that the membrane-bound IDH form could be associated with an integral membrane protein, such as a component of complex I of the respiratory electron transfer chain, a transhydrogenase, or a 2OG transporter (McIntosh, 1997). Three cDNAs encoding different IDH subunits have been isolated from tobacco (Lancien et al., 1998) and five putative IDH genes are present in *Arabidopsis* databases. The complementation of yeast IDH mutants with different tobacco IDH cDNAs indicates that plant IDH is heteromeric (Lancien et al., 1998). Whether IDH is present in several different forms in plants and algae remains to be answered.

To date, a role for IDH in the production of 2OG for ammonium assimilation remains a hypothesis. Recently, the coordinated expression of IDH with other genes of the Krebs cycle, nitrate reduction, and ammonium assimilation in N-starved tobacco plants after nitrate resupply was described (Lancien et al., 1999). Such an observation was taken as indirect evidence for such a role. But, the low measurable IDH activity and the possible build-up of high NADH levels under photorespiratory conditions argue against this function. However, the in vivo IDH activity could be higher than that measured in vitro or tightly regulated. Furthermore, IDH could be associated with other TCA cycle enzymes in a struc-

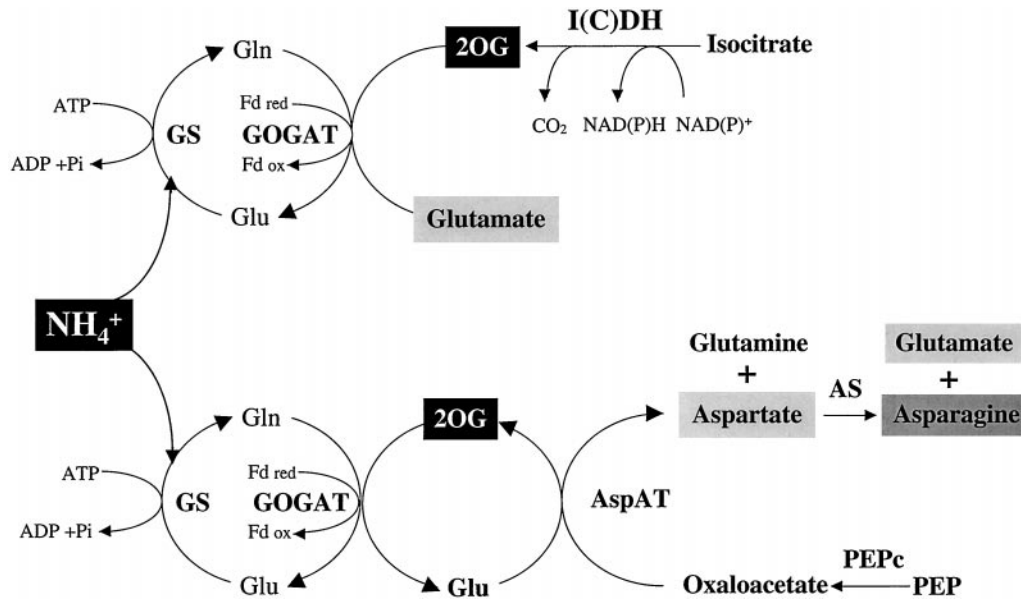

**Figure 2.** Primary amino acid synthesis by the GS/GOGAT cycle in plants. Ammonium is almost exclusively assimilated by the GS/GOGAT pathway. This requires energy, reductant, and C skeletons in the form of 2OG. This organic acid can be synthesized either by an isocitrate dehydrogenase, I(C)DH, or an AspAT. The I(C)DH origin allows for a direct net synthesis of Glu. On the other hand, the AspAT origin produces 2OG at the expense of Glu (no net synthesis) leading to the production of Asp from OAA synthesized via PEPc. The Asp can be used to produce Asn in a reaction carried out by Asn synthase (AS).

tured enzymatic complex termed a metabolon. This might enhance *in vivo* organic acid flux channeling and/or protect IDH (and other TCA cycle dehydrogenases) from inhibition by the predicted high NADH levels generated by the photorespiratory GDC activity. Yet, it is probable that NADH does not accumulate in mitochondria in the light since reducing equivalents are rapidly removed from the mitochondria to the cytosol by the action of a malate/oxaloacetate (OAA) shuttle (Fig. 1).

The second hypothesis is that cytosolic ICDH (ICDH1) could play the role of 2OG production for amino acid synthesis (Fig. 1). In this pathway, citrate transported from the mitochondria to the cytosol is used by a cytosolic aconitase to generate the isocitrate required for 2OG synthesis by ICDH1. This 2OG, of cytosolic origin, is then imported into the plastids. Indirect support for such a hypothesis is abundant in the literature (Gálvez et al., 1999). For instance, nitrate accumulating, nitrate reductase-deficient tobacco plants show a significant increase in ICDH1, GS, GOGAT, phosphoenolpyruvate carboxylase (PEPc), and pyruvate kinase transcript levels (Scheible et al., 1997). These changes were interpreted as evidence for the role of ICDH1 in 2OG production for nitrate-derived ammonium assimilation. However, a study using N-starved tobacco has shown that nitrate does not always lead to an increase in ICDH1 mRNA levels (Lancien et al., 1999). Since ICDH1 is located mainly in leaf and root vascular tissues (Gálvez et al., 1999), this does not favor its role in a major ammonium assimilatory pathway. Since vascular tissues contain GS1

and NADH-GOGAT, ICDH1 could be involved in other metabolic functions related to Gln and Glu production, such as export/import into different tissues (Table II). This would agree with the increase in ICDH transcript and activity levels in senescing potato leaves (Fieuw et al., 1995). A further argument against the role of ICDH1 in photorespiratory ammonium assimilation comes from the analysis of transgenic potato retaining only 8% of normal total ICDH activity (Kruse et al., 1998). These plants did not show any noticeable modification in C or N metabolism and amino acid levels were not significantly altered. Therefore, it appears that ICDH1 is not essential for "normal" GS/GOGAT cycle functioning. However, compensatory pathways might have been induced in such transgenic lines or the residual ICDH1 activity might be sufficient for ammonium assimilation under greenhouse conditions.

#### Transamination Reactions Can Produce 2OG but Do Not Lead Directly to Net Glu Synthesis

AspAT can produce 2OG and Asp via the reversible amino group transfer from Glu to OAA (Table I; Fig. 2). In all higher plants, distinct AspAT isoenzymes are localized within plastids, cytosol, mitochondria, and the peroxisomes (Ireland and Lea, 1999). Five cDNAs have been isolated and characterized from *Arabidopsis* (Schultz and Coruzzi, 1995). The cytosolic and chloroplastic isoforms appear to be most predominant in this plant. Specific, nonoverlapping functions have been proposed for these isoen-

zymes (Table II). AspAT has an important role in the shuttling of redox equivalents between subcellular and cellular compartments as well as in the transfer of nitrogen to Asp that represents an important N donor and transport compound (Fig. 2). Recently, the characterization of an *Arabidopsis Asp2* mutant has shown that this cytosolic isoform is responsible for the synthesis of an Asp pool during the light that is converted to Asn in the dark for N transport within the plant (Schultz et al., 1998). Another important role for AspAT is in the symbiotic N assimilation of legumes. An elevated AspAT activity is found in root nodules, correlated with the induction of AspAT transcript levels during effective nodule development. Although legume roots contain two AspAT forms, the (amylo) plastidial AAT2 is responsible for nodule-located activity (Vance et al., 1994). In this case, Glu is recycled and Asp is synthesized. The crucial organic acid is no longer 2OG but OAA produced by PEPc (Fig. 2).

#### The Mobility of 2OG between Subcellular Compartments Is Required for Ammonium Assimilation

Since 2OG can be synthesized in a number of different subcellular compartments, its mobility could be of major importance in metabolic functioning (Fig. 1). It remains possible that a limiting step in ammonia assimilation is 2OG transport rather than its rate of production. 2OG transport activities have been measured in mitochondria and chloroplasts. Several cDNAs encoding *Panicum miliaceum* mitochondrial 2OGT (mt2OGT) have been isolated but it is not known whether they encode different isoforms with specific functions (Tanigushi and Sugiyama, 1996). The 2OG transporters of chloroplasts (cp2OGT) and mitochondria are not isoforms as they are structurally distinct. In both cases, *in vitro* assays using recombinant transporter proteins show that they are not specific for 2OG and can transport other tri- and dicarboxylates (Weber et al., 1995; Tanigushi and Sugiyama, 1996). Although plastids contain several 2OG-producing enzymes (Table I), their activities are probably too low to sustain the required ammonia assimilatory capacity of this organelle. In plants, cp2OGMT activity is coupled to that of a Glu/malate translocator (Fig. 1; Weber et al., 1995). In this double-translocator system, 2OG entry into the chloroplast is coordinated with Glu export to the cytosol via malate recycling. In the case of mitochondrial 2OG production for ammonia assimilation, a recombinant *P. miliaceum* mt2OGT is capable of carrying out an *in vitro* 2OG/malate exchange (Tanigushi and Sugiyama, 1996). This could reflect the need to attain the obligatory replenishment of TCA cycle intermediates if 2OG is removed from the mitochondria for Glu synthesis.

#### The 2OG Levels Fluctuate in Response to C and N Metabolism, Which May Be Indicative of a Signaling Role of This Intermediate

Plant cell 2OG is present at relatively low levels when compared to other organic acids. It has been shown that 2OG levels depend upon metabolic fluxes related to C and N metabolism, although it is not known whether 2OG fluctuations reflect a change in a given enzymatic activity. Indeed, 2OG levels are dependent on inorganic and organic N content and their related metabolism as well as nitrate and sugar levels (Scheible et al., 1997; Morcuende et al., 1998; Lancien et al., 1999). Taken together, such data indicate that plant cell 2OG levels can reflect C/N status, and therefore this organic acid could play a signaling role in the coordination of C and N metabolism. This is well established for 2OG in bacterial systems.

In bacteria, GS activity is regulated in three ways that include feedback inhibition of GS activity by N metabolites, post-translational modification of GS by reversible covalent adenylation, and transcriptional control of the *GlnA* gene (Ninfa et al., 2000). In *E. coli*, the latter two processes are linked to a signaling process monitoring N and C supply in which the metabolic signals are Gln (indicating N sufficiency) and 2OG (indicating C sufficiency). The antagonistic effects of 2OG and Gln control the regulation of *GlnA* expression via a bicyclic cascade composed of four proteins: NRI, an enhancer-binding transcription factor; NRII, a bifunctional NRI kinase/phosphatase; PII, the signal transduction protein regulating the NRI phosphatase activity of NRII; and UTase/UR, an uridylylating/de-uridylylating enzyme that modifies the binding capacity of PII to NRII. *GlnA* transcriptional activity is controlled by the reversible phosphorylation of NRI, phosphorylated NRI being the active form. Low levels of 2OG lead to the formation of an NRII-PII complex that dephosphorylates and inactivates NRI while high 2OG concentrations inhibit the formation of NRII-PII thus keeping NRI in an active, phosphorylated state. This regulatory mechanism is superimposed with the control brought about by the reversible adenylation of the GS protein that also involves Gln and 2OG. Inactive, adenylated GS is stimulated by PII and Gln, whereas active, deadenylated GS is achieved in the presence of low levels of 2OG and uridylylated PII. Binding studies have shown that PII is the sole receptor for 2OG in this regulatory cascade.

Recently, a gene (*GLB1*) encoding a homolog to the bacterial PII protein has been isolated from *Arabidopsis* (Hsieh et al., 1998). The PII protein identified was chloroplast localized. *GLB1* was expressed in all organs tested and *GLB1* mRNA levels responded to light as well as C and N metabolites. To test whether this regulation was related to PII function in plants, transgenic tobacco that constitutively overexpressed *GLB1* were created and analyzed. These transgenic plants appeared to be altered in C/N sensing, as

judged by an *in vivo* assay; Gln reversal of Suc induced anthocyanin accumulation (Hsieh et al., 1998). It is still not clear whether this PII protein is involved in the regulation of GS transcription or post-transcriptional control in plants. Recently, an external 2OG supply was shown to induce an increase of GS1 transcripts in *Arabidopsis* roots (Oliveira and Coruzzi, 1999). Furthermore, an antagonistic effect of added amino acids, such as Gln, on Suc-induced GS expression was also observed. The authors suggested that the metabolic regulation of GS expression in plants was controlled by the relative abundance of C skeletons versus amino acids. Further biochemical and molecular studies are necessary to confirm if 2OG is really an important signal in a transduction pathway controlling gene expression and involving a PII sensing protein.

However, 2OG is a direct regulator of enzymes such as cytosolic pyruvate kinase, mitochondrial citrate synthase, and alternative oxidase activities; all involved in sugar/organic acid flux and redox control between cytosol and mitochondria. In this way, it is possible that 2OG acts as a regulatory metabolite coordinating mitochondrial, cytosolic, and chloroplastic metabolisms so as to adjust C-skeleton production or cellular redox regulation to amino acid synthesis. Again, plant cell 2OG levels might be involved in the control of plant development due to the important role of 2OG-dependent gibberellin oxidases in the production of active gibberellins.

## PERSPECTIVES

In this review recent arguments for and against the role of different isoenzymes involved in ammonium assimilation and 2OG synthesis are discussed. However, the presence of isoenzyme families and the high degree of compartmentalization still render this problem complex. This situation reflects the plants' need for metabolic flexibility to respond to changing environmental conditions. For instance, in the case of the origin of 2OG for ammonia assimilation, the contradictory observations found in the literature probably reflect the fact that different enzymes contribute depending on tissue and specific physiological condition(s). The identification and characterization of *null* mutants for a specific enzyme will help us to better understand the non-redundant roles of the different 2OG-producing enzymes. This approach has already led to significant advances in this domain, as seen for GS and GOGAT isoforms. However the characterization of N-assimilation mutants remain often partial and further progress to unravel the dynamic, flexible nature of plant metabolism will be made only if an integrated, whole-plant approach is developed.

It has become clear that C and N metabolisms are regulated to bring about the coordination essential for plant growth and development. However, although numerous C and N metabolic compounds have been shown to modify gene expression and

enzymatic activities, a number of interesting and fundamental questions remain to be answered. Which metabolites are important in controlling the coordination of C and N metabolisms? How do the signals lead to the regulation of gene and enzyme activities? The idea that, as in prokaryotic cells, C/N status is monitored by changing 2OG and Gln levels is of great interest. The possible role of 2OG as a signaling molecule remains to be elucidated. The recent discovery of *GLB1* opens up the door to examine such a hypothesis. In the years that follow, significant progress awaits to be made in the intriguing area of metabolic sensing and signaling in plants.

## ACKNOWLEDGMENTS

We would like to thank Dr. A. Weber for sharing unpublished data, Drs. J. Vidal, S. Ferrario, B. Hirel, and S. Gálvez for many animated discussions, and Profs. G. Coruzzi and M.J. Chrispeels for helpful comments. We are also grateful to Drs. A. Ninfa, R. Ireland, and Prof. P.J. Lea for kindly sending us recent publications. Due to space limitations, the authors would like to apologize to all those we have not been able to cite.

Received January 21, 2000; accepted March 6, 2000.

## LITERATURE CITED

- Brugière N, Dubois F, Limami AM, Lelandais M, Roux Y, Sangwan RS, Hirel B (1999) Glutamine synthetase in the phloem plays a major role in controlling proline production. *Plant Cell* **21**: 1995–2011
- Buchanan-Wollaston V, Ainsworth C (1997) Leaf senescence in *Brassica napus*: cloning of senescence related genes by subtractive hybridization. *Plant Mol Biol* **33**: 821–834
- Coschigano KT, Melo-Oliveira R, Lim J, Coruzzi GM (1998) *Arabidopsis gls* mutants and distinct Fd-GOGAT genes: implications for photorespiration and primary nitrogen assimilation. *Plant Cell* **10**: 741–752
- Fieuw S, Müller-Röber B, Gálvez S, Willmitzer L (1995) Cloning and expression analysis of the cytosolic NADP<sup>+</sup>-dependent isocitrate dehydrogenase from potato. *Plant Physiol* **107**: 905–913
- Gálvez S, Lancien M, Hodges M (1999) Are isocitrate dehydrogenases and 2-oxoglutarate involved in the regulation of Glu synthesis? *Trends Plant Sci* **4**: 484–490
- Hayakawa T, Hopkins L, Peat LJ, Yamaya T, Tobin AK (1999) Quantitative intercellular localization of NADH-dependent glutamate synthase protein in different types of root cells in rice plants. *Plant Physiol* **119**: 409–416
- Hirose N, Hayakawa T, Yamaya T (1997) Inducible accumulation of mRNA for NADH-dependent glutamate synthase in rice roots in response to ammonium ions. *Plant Cell Physiol* **38**: 1295–1297
- Hsieh M-H, Lam H-M, van de Loo FJ, Coruzzi G (1998) A

- PII-like protein in *Arabidopsis*: putative role in nitrogen sensing. *Proc Natl Acad Sci USA* **95**: 13965–13970
- Ireland RJ, Lea PJ** (1999) The enzymes of glutamine, glutamate, asparagine and aspartate metabolism. In BK Singh, ed, *Plant Amino Acids: Biochemistry and Biotechnology*. Marcel Dekker, New York, pp 49–109
- Kruse A, Fieuw S, Heineke D, Müller-Röber B** (1998) Antisense inhibition of cytosolic NADP-dependent isocitrate dehydrogenase in transgenic potato plants. *Planta* **205**: 82–91
- Lancien M, Ferrario-Mery S, Roux Y, Bismuth E, Masclaux C, Hirel B, Gadal P, Hodges M** (1999) Simultaneous expression of NAD-dependent isocitrate dehydrogenase and other Krebs cycle genes after nitrate re-supply to short-term nitrogen-starved tobacco. *Plant Physiol* **120**: 717–725
- Lancien M, Gadal P, Hodges M** (1998) Molecular characterization of higher plant NAD-dependent isocitrate dehydrogenase: evidence for a heteromeric structure by the complementation of yeast mutants. *Plant J* **16**: 325–333
- Lea PJ, Ireland RJ** (1999) Nitrogen metabolism in higher plants. In BK Singh, ed, *Plant Amino Acids: Biochemistry and Biotechnology*. Marcel Dekker, New York, pp 1–47
- Long LM, Lightfoot DA** (1996) Field evaluation and nitrogen use efficiency of transgenic tobacco expressing the *E. coli* glutamate dehydrogenase gene. *Plant Physiol* **111**: S–91
- Martínez-Rivas JM, Vega JM** (1998) Purification and characterization of NAD-isocitrate dehydrogenase from *Chlamydomonas reinhardtii*. *Plant Physiol* **118**: 249–255
- McIntosh CA** (1997) Partial purification and characteristics of membrane-associated NAD<sup>+</sup>-dependent isocitrate dehydrogenase activity from etiolated pea mitochondria. *Plant Sci* **129**: 9–20
- Melo-Oliveira R, Oliveira IC, Coruzzi GM** (1996) *Arabidopsis* mutant analysis and gene regulation define a non-redundant role for glutamate dehydrogenase in nitrogen assimilation. *Proc Natl Acad Sci USA* **93**: 4718–4723
- Morcuende R, Krapp A, Hurry V, Stitt M** (1998) Suc feeding leads to increased rates of nitrate assimilation, increased rates of 2-oxoglutarate synthesis, and increased synthesis of a wide spectrum of amino acids in tobacco leaves. *Planta* **206**: 394–409
- Ninfa A, Jiang P, Atkinson MR, Peliska JA** (2000) Integration of antagonistic signals in the regulation of nitrogen assimilation in *Escherichia coli*. *Curr Topics Cell Reg* **36**: 31–75
- Oliveira IC, Coruzzi G** (1999) Carbon and amino acids reciprocally modulate the expression of glutamine synthetase in *Arabidopsis*. *Plant Physiol* **121**: 301–309
- Robinson SA, Stewart GR, Phillips R** (1992) Regulation of glutamate dehydrogenase activity in relation to carbon limitation and protein catabolism in carrot cell suspension cultures. *Plant Physiol* **98**: 1190–1195
- Scheible W-R, González-Fontes A, Lauerer M, Müller-Röber B, Caboche M, Stitt M** (1997) Nitrate acts as a signal to induce organic acid metabolism and repress starch metabolism in tobacco. *Plant Cell* **9**: 783–798
- Schultz CJ, Coruzzi GM** (1995) The aspartate aminotransferase gene family of *Arabidopsis* encodes isoenzymes localized to three distinct subcellular compartments. *Plant J* **7**: 61–75
- Schultz CJ, Hsu M, Miesak B, Coruzzi GM** (1998) *Arabidopsis* mutants define an *in vivo* role for isoenzymes of aspartate aminotransferase in plant nitrogen assimilation. *Genetics* **149**: 491–499
- Tanigushi M, Sugiyama T** (1996) Isolation, characterization and expression of cDNA clones encoding a mitochondrial malate translocator from *Panicum miliaceum* L. *Plant Mol Biol* **30**: 51–64
- Temple SJ, Vance CP, Gantt JS** (1998) Glutamate synthase and nitrogen assimilation. *Trends Plant Sci* **3**: 51–56
- Vance CP, Gregerson RG, Robinson DL, Miller SS, Gantt JS** (1994) Primary assimilation of nitrogen in alfalfa nodules: molecular features of the enzymes involved. *Plant Sci* **101**: 51–64
- Vincent R, Fraisier V, Chaillou S, Limami MA, Deleens E, Phillipson B, Douat C, Boutin JP, Hirel B** (1997) Overexpression of a soybean gene encoding cytosolic glutamine synthetase in shoots of transgenic *Lotus corniculatus* L. plants triggers changes in ammonium assimilation and plant development. *Planta* **201**: 424–433
- Weber A, Menzlaff E, Arbinger B, Gutensohn M, Ecker-skorn C, Flügge UI** (1995) The 2-oxoglutarate/malate translocator of chloroplast envelope membranes: molecular cloning of a transporter containing a 12-helix motif and expression of the functional protein in yeast cells. *Biochemistry* **34**: 2621–2627