

01 Jan 2007

Error Performance of Double Space Time Transmit Diversity Systems

Jingxian Wu

Y. Rosa Zheng

Missouri University of Science and Technology, zhengyr@mst.edu

Ashwin Gumaste

Chengshan Xiao

Missouri University of Science and Technology, xiaoc@mst.edu

Follow this and additional works at: https://scholarsmine.mst.edu/ele_comeng_facwork



Part of the [Electrical and Computer Engineering Commons](#)

Recommended Citation

J. Wu et al., "Error Performance of Double Space Time Transmit Diversity Systems," *IEEE Transactions on Wireless Communications*, Institute of Electrical and Electronics Engineers (IEEE), Jan 2007.

The definitive version is available at <https://doi.org/10.1109/TWC.2007.06030040>

This Article - Journal is brought to you for free and open access by Scholars' Mine. It has been accepted for inclusion in Electrical and Computer Engineering Faculty Research & Creative Works by an authorized administrator of Scholars' Mine. This work is protected by U. S. Copyright Law. Unauthorized use including reproduction for redistribution requires the permission of the copyright holder. For more information, please contact scholarsmine@mst.edu.

Error Performance of Double Space Time Transmit Diversity System

Jingxian Wu, *Member, IEEE*, Yahong Rosa Zheng, *Senior Member, IEEE*, Ashwin Gumaste, *Member, IEEE*, and Chengshan Xiao, *Senior Member, IEEE*

Abstract—The theoretical error performance of double space time transmit diversity (DSTTD) system with optimum combining receiver is analyzed in this paper. By employing both spatial multiplexing and transmit diversity in one system, DSTTD provides practical tradeoff between system spectral efficiency and diversity gain. We derive exact analytical expressions to describe the symbol error rate for DSTTD systems. The effects of both diversity gain and antenna interference introduced by spatial multiplexing are quantified in the results. In addition, the performance of DSTTD system with successive interference cancellation is also investigated. Simulation results are in excellent agreement with the theoretical results obtained in this paper.

Index Terms—Double space time transmit diversity, error performance, successive interference cancellation.

I. INTRODUCTION

THE next generation wireless communication system is required to provide high quality voice service as well as broadband data services. To achieve this goal, multiple-input multiple-output (MIMO) systems with multiple antennas at both transmitter and receiver are adopted to utilize the spatial domain of the wireless communication system.

The spatial dimension of MIMO systems can be explored in two different ways, spatial multiplexing [1] or transmit diversity [2] – [4]. In a system with spatial multiplexing, different data streams are sent out by different transmit antennas simultaneously to improve the overall system throughput. On the contrary, transmit diversity system has one data stream spatially encoded across all transmission antennas to achieve spatial fading diversity. Spatial multiplexing and transmit diversity feature the fundamental tradeoff between spectral efficiency and diversity gain in wireless communication systems [5], [6]. Spatial multiplexing improves system spectral efficiency at the cost of diversity gain, while diversity gain is achieved in transmit diversity system by trading off spectral efficiency.

Manuscript received March 18, 2006; revised July 10, 2006; accepted September 8, 2006. The associate editor coordinating the review of this paper and approving it for publication is D. Huang. The work of Y. R. Zheng was supported in part by the University of Missouri System Research Board. The work of C. Xiao was supported in part by the National Science Foundation under Grant CCF-0514770 and the University of Missouri-Columbia Research Council under Grant URC-05-064. Part of this paper was previously presented at the 2006 IEEE International Conference on Communications (ICC'06), Istanbul, Turkey.

J. Wu is with the Department of Engineering Science, Sonoma State University, Rohnert Park, CA 94928, USA (email: jingxian.wu@sonoma.edu).

Y. R. Zheng is with the Department of Electrical and Computer Engineering, University of Missouri, Rolla, MO 65409 USA (e-mail: zhengyr@umr.edu).

A. Gumaste is with the India Institute of Technology, Bombay, India.

C. Xiao is with the Department of Electrical and Computer Engineering, University of Missouri, Columbia, MO 65211 USA (e-mail: xiaoac@missouri.edu).

Digital Object Identifier 10.1109/TWC.2007.06030040.

The tradeoff relationship between spatial multiplexing and transmit diversity was exploited in the design of various MIMO systems [7] – [10].

Specifically, double space time transmit diversity (DSTTD) [10] provides a simple yet effective solution to achieve spatial multiplexing and transmit diversity in one system. DSTTD system has four transmit antennas divided into two 2-antenna groups, with the two antennas in each group associated with an orthogonal space time transmit diversity (STTD) encoder. Spatial multiplexing are employed across groups, *i.e.*, different data streams are sent out by different groups. DSTTD technique operates on a practical tradeoff point between spatial multiplexing and transmit diversity. The error performance of DSTTD system was studied with simulations in [10] and [11]. The theoretical error performance of DSTTD system with zero-forcing decision feedback receiver was derived in [12], where ideal interference cancellation of all data streams are assumed.

In this paper, we derive exact analytical error probability expressions for linearly modulated DSTTD systems with optimum combining receivers and independent identically distributed (i.i.d.) Rayleigh fading channels. The difficulty in DSTTD system performance analysis mainly arises from the interference among the spatially multiplexed transmission antennas. We tackle this problem by analyzing the eigen-structure of the interference correlation matrix, which leads to closed-form expressions of the moment generating function (MGF) of the post-detection signal to interference plus noise ratio (SINR) at the receiver. The statistical properties of the post-detection SINR are used to facilitate the system error probability analysis. The effects of both spatial diversity and inter-group interference are taken into account during the performance analysis. The statistical properties of the post-detection SINR is analyzed by examining the eigen-structure of the correlation matrix of the interfering channels. Closed-form expressions are derived for the MGF of the post-detection SINR, and the results are employed in the error probability analysis.

Successive interference cancellation (SIC) can be employed at DSTTD receiver to improve the overall system performance at the cost of system complexity [10]. The theoretical performance of DSTTD system with SIC is also investigated in this paper, and the results are compared to DSTTD systems without SIC to demonstrate the impact of SIC on system performance.

The rest of the paper is organized as follows. Section II describes the model and operation of DSTTD system. In Section III, the theoretical error performances of DSTTD system with and without SIC are derived by analyzing the

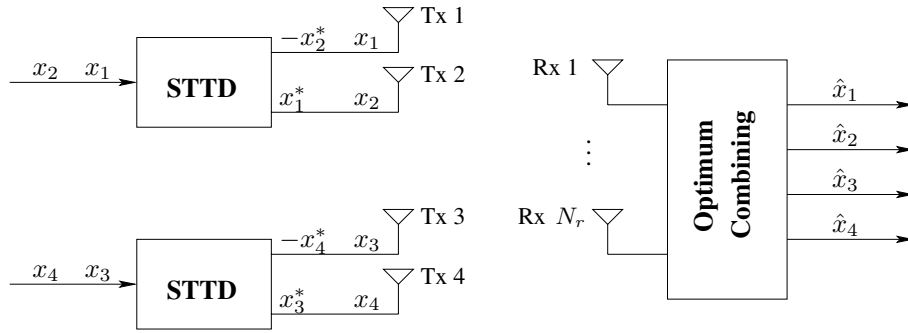

Fig. 1. The block diagram of a DSTTD system.

statistical properties of the post-detection SINR. Numerical examples are given in Section IV to validate the analytical results, and Section V concludes the paper.

II. SYSTEM MODEL

The block diagram of a DSTTD system with $N_t = 4$ transmission antennas and $N_r \geq 2$ receive antennas is shown in Fig. 1. The input information symbols are demultiplexed into two data streams, each stream is encoded by an orthogonal STTD encoder. The output of the two orthogonal STTD encoders at two consecutive symbol periods t_1 and t_2 can be represented by a size 4×2 matrix as

$$\mathbf{C} = \{c_{ij}\}_{4 \times 2} = \begin{bmatrix} x_1 & x_2 & x_3 & x_4 \\ -x_2^* & x_1^* & -x_4^* & x_3^* \end{bmatrix}^T \in \mathcal{C}^{4 \times 2} \quad (1)$$

where $(\cdot)^*$ denotes the operation of complex conjugate, $(\cdot)^T$ represents matrix transpose, and x_i is an M -ary modulated symbol with power E_s . For each element c_{ij} in the matrix \mathbf{C} , the column index j corresponds to the time instant t_j , for $j = 1$ or 2 , whereas the symbol on the i th row of \mathbf{C} is going to be sent out by the i th transmission antenna, with $i \in \{1, 2, 3, 4\}$.

In the channel, the transmitted signal is corrupted by both frequency flat Rayleigh fading and additive noise. To maintain the orthogonality of the STTD encoding scheme, the channel is assumed to be varying slowly enough that the fading remains constant for two consecutive symbol periods [2]. Let h_{nm} denote the fading coefficient between the m th transmission antenna and the n th receive antenna, then the signals collected by the n th receive antenna at time instant t_j can be written as

$$r_{nj} = [h_{n1} \ h_{n2} \ h_{n3} \ h_{n4}] \cdot \mathbf{c}_j + z_{nj}, \text{ for } j = 1, 2. \quad (2)$$

where r_{nj} is the received signal of the n th receive antenna at time instant t_j , z_{nj} is the corresponding additive white Gaussian noise (AWGN) component with variance N_0 , and \mathbf{c}_j is the j th column of the encoded data matrix \mathbf{C} . With simple algebraic manipulation of (1) and (2), we have

$$\begin{bmatrix} r_{n1} \\ r_{n2}^* \end{bmatrix} = \begin{bmatrix} h_{n1} & h_{n2} & h_{n3} & h_{n4} \\ h_{n2}^* & -h_{n1}^* & h_{n4}^* & -h_{n3}^* \end{bmatrix} \begin{bmatrix} x_1 \\ x_2 \\ x_3 \\ x_4 \end{bmatrix} + \begin{bmatrix} z_{n1} \\ z_{n2}^* \end{bmatrix},$$

or in matrix format

$$\mathbf{r}_n = \mathbf{H}_n \cdot \mathbf{x} + \mathbf{z}_n, \quad \text{for } n = 1, 2, \dots, N_r. \quad (3)$$

Stacking up the N_r receive vectors \mathbf{r}_n leads to the input-output relationship of the system as

$$\mathbf{r} = \mathbf{H} \cdot \mathbf{x} + \mathbf{z}, \quad (4)$$

where

$$\mathbf{r} = [\mathbf{r}_1^T \ \mathbf{r}_2^T \ \dots \ \mathbf{r}_{N_r}^T]^T \in \mathcal{C}^{(2N_r) \times 1}, \quad (5a)$$

$$\mathbf{H} = [\mathbf{H}_1^T \ \mathbf{H}_2^T \ \dots \ \mathbf{H}_{N_r}^T]^T \in \mathcal{C}^{(2N_r) \times 4}, \quad (5b)$$

$$\mathbf{z} = [\mathbf{z}_1^T \ \mathbf{z}_2^T \ \dots \ \mathbf{z}_{N_r}^T]^T \in \mathcal{C}^{(2N_r) \times 1}. \quad (5c)$$

with $\mathbf{r}_n \in \mathcal{C}^{2 \times 1}$, $\mathbf{H}_n \in \mathcal{C}^{2 \times 4}$, and $\mathbf{z}_n \in \mathcal{C}^{2 \times 1}$ defined in (3).

From (4), the system is equivalently represented by a spatially multiplexed MIMO system with four transmission antennas and $2N_r$ receive antennas. Four input streams, $\{x_1, x_2, x_3, x_4\}$, are spatially multiplexed across the transmission antennas. Correspondingly, the equivalent channel matrix, \mathbf{H} , has four column fading vectors, $\{\mathbf{h}_1, \mathbf{h}_2, \mathbf{h}_3, \mathbf{h}_4\}$, with each fading vector relevant to one of the four data streams.

The four transmission streams can be further partitioned into two groups based on the two STTD encoders. The first and second data streams $\{x_1, x_2\}$ are in group 1 associated with the first STTD encoder, and the second group contains the third and fourth data streams $\{x_3, x_4\}$ related to STTD encoder 2. Due to the orthogonality of the STTD encoder, the channel vectors belonging to the same transmission group are orthogonal to each other, *i.e.*,

$$\mathbf{h}_1^H \mathbf{h}_2 = \mathbf{h}_2^H \mathbf{h}_1 = 0, \quad (6a)$$

$$\mathbf{h}_3^H \mathbf{h}_4 = \mathbf{h}_4^H \mathbf{h}_3 = 0. \quad (6b)$$

However, there are still interferences between the data streams belonging to different transmission groups, and this interference will seriously affect the performance of the DSTTD system.

III. PERFORMANCE ANALYSIS

A. Optimum Combining

To suppress the interference between the two spatially multiplexed transmission groups, optimum combining (OC) is employed at the receiver. The OC detection vectors for the k th data stream can be written by [13]

$$\mathbf{w}_k = \left(\mathbf{B}_k + \frac{1}{\rho} \mathbf{I}_{2N_r} \right)^{-1} \mathbf{h}_k \quad (7)$$

where $\rho = E_s/N_0$ is the signal to noise ratio (SNR) of one data stream without fading, \mathbf{I}_{2N_r} is a $2N_r \times 2N_r$ identity matrix, and the matrix \mathbf{B}_k is the interference covariance matrix defined below

$$\mathbf{B}_k = \begin{cases} \mathbf{h}_3\mathbf{h}_3^H + \mathbf{h}_4\mathbf{h}_4^H, & \text{for } k = 1, 2, \\ \mathbf{h}_1\mathbf{h}_1^H + \mathbf{h}_2\mathbf{h}_2^H, & \text{for } k = 3, 4. \end{cases} \quad (8)$$

From the OC weight vector given in (7), the detection variable for the k th data stream can be formulated as $\mathbf{w}_k^H \mathbf{r}_k$, and the corresponding SINR of the k th data stream is

$$\gamma_k = \frac{|\mathbf{w}_k^H \mathbf{h}_k|^2}{\mathbf{w}_k^H \left(\mathbf{B}_k + \frac{1}{\rho} \mathbf{I}_{2N_r} \right) \mathbf{w}_k}. \quad (9)$$

To simplify the SINR representation given in (9), we left multiply both sides of (7) with $\mathbf{w}_k^H \left(\mathbf{B}_k + \frac{1}{\rho} \mathbf{I}_{2N_r} \right)$, and the result is

$$\mathbf{w}_k^H \left(\mathbf{B}_k + \frac{1}{\rho} \mathbf{I}_{2N_r} \right) \mathbf{w}_k = \mathbf{w}_k^H \mathbf{h}_k. \quad (10)$$

Substituting (10) into (9) yields

$$\gamma_k = \mathbf{w}_k^H \mathbf{h}_k. \quad (11)$$

Combining (7) with (11) leads to an alternative representation of the SINR as

$$\gamma_k = \mathbf{h}_k^H \left(\mathbf{B}_k + \frac{1}{\rho} \mathbf{I}_{2N_r} \right)^{-1} \mathbf{h}_k, \quad (12)$$

with the matrix \mathbf{B}_k defined in (8). The statistical properties of the SINR given in (12) is analyzed in the next subsection to facilitate the error performance analysis.

B. Statistical Properties of the SINR

For i.i.d. fading channels with variance normalized to unity, the post-detection SINR of the four data streams share the same statistical properties. Without loss of generality, the analysis is performed for the first data stream, x_1 , and the results can be directly applied to other data streams.

From (8) and (12), the SINR γ_1 can be written as

$$\gamma_1 = \mathbf{h}_1^H \left(\mathbf{h}_3\mathbf{h}_3^H + \mathbf{h}_4\mathbf{h}_4^H + \frac{1}{\rho} \mathbf{I}_{2N_r} \right)^{-1} \mathbf{h}_1. \quad (13)$$

Performing eigenvalue decomposition (EVD) for the interference covariance matrix $\mathbf{B}_1 = \mathbf{h}_3\mathbf{h}_3^H + \mathbf{h}_4\mathbf{h}_4^H$ yields $\mathbf{B}_1 = \mathbf{U}\mathbf{\Lambda}\mathbf{U}^H$. The matrices \mathbf{U} and $\mathbf{\Lambda}$ are defined as

$$\mathbf{U} = [\mathbf{u}_1 \quad \mathbf{u}_2 \quad \cdots \quad \mathbf{u}_{N_r}] \in \mathcal{C}^{2N_r \times 2N_r}, \quad (14a)$$

$$\mathbf{\Lambda} = \text{diag} [\lambda_1 \quad \lambda_2 \quad 0 \quad \cdots \quad 0] \in \mathcal{C}^{2N_r \times 2N_r} \quad (14b)$$

where $\mathbf{\Lambda}$ is a diagonal matrix, with the diagonal elements λ_k being the eigenvalues of \mathbf{B}_1 , and \mathbf{u}_k are the corresponding orthonormal eigenvectors defining the eigen-space. Since \mathbf{h}_3 and \mathbf{h}_4 are linearly independent, there are only two non-zero eigenvalues, λ_1 and λ_2 . Due to the orthonormality of the eigenvectors, the matrix \mathbf{U} is unitary, i.e., $\mathbf{U}^H\mathbf{U} = \mathbf{I}_{2N_r}$.

With EVD, The SINR given in (13) can be rewritten as

$$\gamma_1 = \mathbf{h}_1^H \mathbf{U} \left(\mathbf{\Lambda} + \frac{1}{\rho} \mathbf{I}_{2N_r} \right)^{-1} \mathbf{U}^H \mathbf{h}_1. \quad (15)$$

If we define a new vector, $\mathbf{g} = \mathbf{U}^H \mathbf{h}_1$, then the SINR γ_1 can be further simplified to

$$\gamma_1 = \sum_{k=1}^2 \frac{|g_k|^2}{\lambda_k + 1/\rho} + \sum_{k=3}^{2N_r} |g_k|^2 \cdot \rho. \quad (16)$$

where g_k is the k th element of the vector \mathbf{g} . Based on the facts that \mathbf{U} is unitary and it is independent of \mathbf{h}_1 , the vector \mathbf{g} is still zero-mean complex Gaussian distributed with covariance matrix $\mathbb{E}[\mathbf{g}\mathbf{g}^H] = \mathbf{I}_{2N_r}$.

The SINR given in (16) conditioned on the eigenvalues λ_1 and λ_2 is the summation of $2N_r$ independent exponentially distributed random variables (RV). Thus, the MGF $M_{\gamma|\lambda}(s) = \mathbb{E}_{\gamma_1|\lambda}(e^{s\gamma})$ of γ_1 conditioned on λ_1 and λ_2 is [14]

$$M_{\gamma|\lambda}(s) = \frac{1}{(1 - \frac{s}{\lambda_1 + 1/\rho})} \frac{1}{(1 - \frac{s}{\lambda_2 + 1/\rho})} \frac{1}{(1 - \rho s)^{2N_r - 2}}, \quad (17)$$

where $\mathbb{E}(\cdot)$ represents mathematical expectation.

The derivation of the unconditional MGF requires the knowledge of the distribution of λ_k . For a general interference covariance matrix as defined in (8), it is usually very difficult to find the expressions of the eigenvalues. However, for DSTTD system, the vectors \mathbf{h}_3 and \mathbf{h}_4 are mutually orthogonal to each other. The orthogonality between the interfering vectors leads to an explicit representation of the eigenvalues λ_1 and λ_2 as [14, p. 457]

$$\lambda_1 = \lambda_2 = \sum_{k=1}^{2N_r} (|h_{n3}|^2 + |h_{n4}|^2) = \lambda. \quad (18)$$

Since the fading coefficients are zero-mean Complex Gaussian distributed, the eigenvalues given in (18) are χ^2 -distributed with $8N_r$ degrees of freedom. The probability density function (pdf) of λ is given by [14]

$$p(\lambda) = \frac{\lambda^{2N_r - 1}}{\Gamma(2N_r)} \exp(-\lambda). \quad (19)$$

With the pdf of the eigenvalues defined in (19), the unconditional MGF $M_\gamma(s)$ can be obtained by integrating (17) over the distribution of λ as

$$M_\gamma(s) = \int_0^{+\infty} \frac{1}{(1 - \frac{s}{\lambda + 1/\rho})^2} \frac{\lambda^{2N_r - 1}}{\Gamma(2N_r)} \exp(-\lambda) d\lambda \times \frac{1}{(1 - \rho s)^{2N_r - 2}}. \quad (20)$$

With the procedures described in the Appendix, the MGF of (20) can be expressed in closed-form as in (21), which is shown at the top of the next page. In (21), $\Gamma(a, x) = \int_x^{+\infty} t^{a-1} e^{-t} dt$ is the incomplete Gamma function [16, (8.350.2)].

Eqn. (21) gives the unconditional MGF of the SINR γ_1 at the presence of interferences from \mathbf{h}_3x_3 and \mathbf{h}_4x_4 . If no interference cancellation is employed at the receiver, then (21) can be used to describe the MGF of the SINR of all the four spatially multiplexed data streams.

Successive interference cancellation can be used at the receiver to further improve system performance. Without loss of generality, it's assumed here that the streams in the group $\{x_1, x_2\}$ are detected first, and the results are used in interference cancellation for data streams $\{x_3, x_4\}$. For ideal

Table 1. Parameters of (24) for Various Modulation Schemes.

Modulation	ζ	β_1	β_2	ψ_1	ψ_2
MPSK	$\sin^2 \frac{\pi}{M}$	1	0	$\pi - \frac{\pi}{M}$	0
MASK	$\frac{3}{M^2-1}$	$2(1 - \frac{1}{M})$	0	$\frac{\pi}{2}$	0
MQAM	$\frac{3}{2(M-1)}$	$4(1 - \frac{1}{\sqrt{M}})$	$-4(1 - \frac{1}{\sqrt{M}})^2$	$\frac{\pi}{2}$	$\frac{\pi}{4}$

$$\begin{aligned}
M_\gamma(s) &= \frac{1}{(1-\rho s)^{2N_r-2}} \times \left[1 + (2s-s^2) \left(\frac{1}{\rho} - s \right)^{2N_r-1} \right. \\
&\quad \times \exp \left(\frac{1}{\rho} - s \right) \Gamma \left(1 - 2N_r, \frac{1}{\rho} - s \right) + s^2 \left(\frac{1}{\rho} - s \right)^{2N_r-2} \\
&\quad \left. \times \exp \left(\frac{1}{\rho} - s \right) \Gamma \left(2 - 2N_r, \frac{1}{\rho} - s \right) \right], \quad (21)
\end{aligned}$$

interference cancellation, the post-detection SNR, $\hat{\gamma}_3$ and $\hat{\gamma}_4$, can be written as

$$\hat{\gamma}_3 = \hat{\gamma}_4 = \rho \cdot \sum_{n=1}^{N_r} (|h_{n3}|^2 + |h_{n4}|^2) = \rho \cdot \lambda, \quad (22)$$

with λ being defined in (18). The corresponding MGF of the χ^2 -distributed SNR, $\hat{\gamma}_k$, is

$$M_{\hat{\gamma}}(s) = \frac{1}{(1-\rho s)^{2N_r}}. \quad (23)$$

The MGFs of the post-detection SINR or SNR will be used in the error performance analysis.

C. Performance Analysis

In this subsection, we derive the symbol error rate (SER) expression for linearly modulated systems, such as M-ary Amplitude Shift Keying (MASK), M-ary Phase Shift Keying (MPSK), and square M-ary Quadrature Amplitude Modulation (MQAM).

For MASK, MPSK, and MQAM systems, the error probability of each individual data stream can be written in a unified form as [15]

$$P(E) = \sum_{i=1}^2 \frac{\beta_i}{\pi} \int_0^{\psi_i} M_\gamma \left(-\frac{\zeta}{\sin^2 \theta} \right) d\theta, \quad (24)$$

where the values of the parameters β_i , ψ_i and ζ for different modulation schemes are given in Table 1, and $M_\gamma(s)$ is the MGF of the SINR (or SNR) as defined in Section III-B.

For system without interference cancellation, the post-detection SINR, γ_n , for $n = 1, 2, 3, 4$, follow the same statistical distribution. Therefore, the overall symbol error rate (SER) of the entire system, which can be calculated by averaging over the individual SER of the four data streams, is obviously equal to the SER of any of the four data streams. Thus, the exact overall symbol error rate for DSTTD system without interference cancellation can be obtained by replacing $M_\gamma \left(-\frac{\zeta}{\sin^2 \theta} \right)$ of (24) with that defined in (21). The integral in (24) only involves elementary functions and small integration limits, thus it can be easily evaluated with numerical methods.

On the other hand, for system with ideal SIC, there is no interference present at one of the two transmission groups. The

overall system error probability can be obtained by averaging the SER of the two transmission groups as

$$P(E) = \sum_{i=1}^2 \frac{\beta_i}{2\pi} \int_0^{\psi_i} \left[M_\gamma \left(-\frac{\zeta}{\sin^2 \theta} \right) + M_{\hat{\gamma}} \left(-\frac{\zeta}{\sin^2 \theta} \right) \right] d\theta, \quad (25)$$

where $M_\gamma(s)$ is the SINR MGF defined in (21), and $M_{\hat{\gamma}}(s)$ is the MGF for the SNR given by (23). The error probability given in (25) is based on the assumption of ideal interference cancellation. However, for practical systems, residual interference is always present at the receiver, especially at low SNR. Thus the error probability given by (25) can be treated as a lower bound for DSTTD system with practical SIC receiver.

IV. NUMERICAL EXAMPLES

Numerical examples are provided in this section to validate the analytical expressions derived in this paper as well as to compare the performance of DSTTD systems under various system configurations.

During the simulation, the total transmission power from the four transmission antennas are normalized to 1. As a common practice of digital communication systems, E_b/N_0 is used as a metric to measure the SNR of the system. The relationship between E_b/N_0 and the per data stream SNR ρ used in the analytical SER expressions can be described as

$$\rho = \frac{E_b/N_0 \cdot \log_2 M}{N_t} \quad (26)$$

where N_t is the number of transmission antennas, and M is the modulation constellation size.

Fig. 2 plots the SER of 8PSK modulated DSTTD system with different number of receive antennas. In this example, no interference cancellation is employed at the receiver. In Fig. 2, the SER results from the analytical error expressions are compared to those obtain from simulations, and perfect agreement between them are observed. In addition, as expected, the error performance improves with the number of receive antennas thanks to the increase of spatial diversity order contributed by the receive antennas.

The impact of interference cancellation on system performance is illustrated in Fig. 3 for QPSK and 16QAM modulated systems. Four antennas are used at the receiver. It's apparent from Fig. 3 that systems with SIC (labeled as

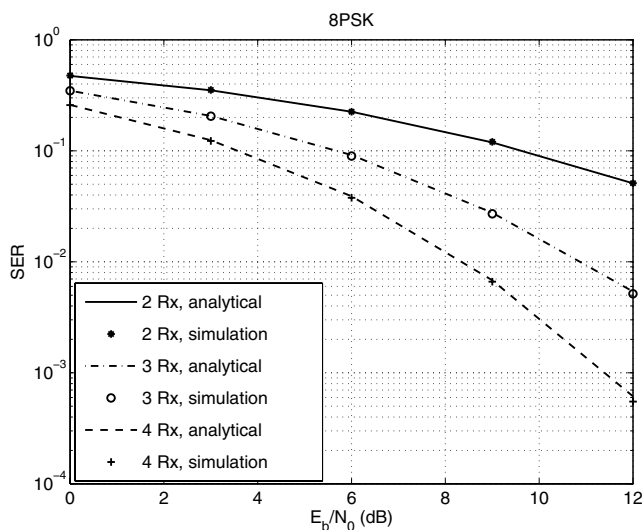

Fig. 2. Error performance of 8PSK modulated DSTTD system with different number of Rx antennas.

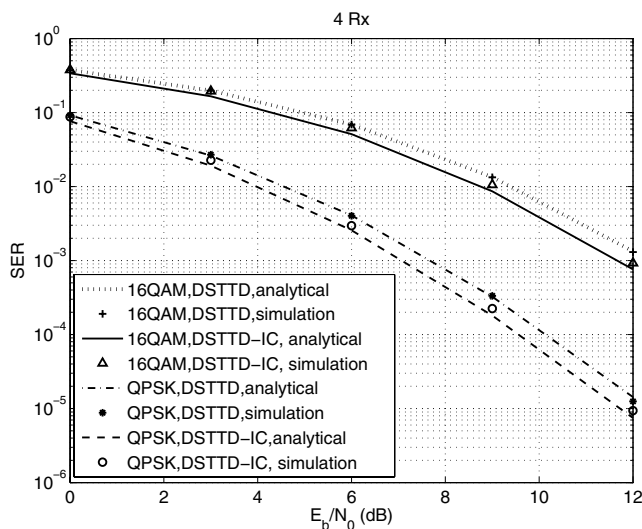

Fig. 3. Comparison of the error performances of DSTTD systems with and without interference cancellation.

DSTTD-IC) always outperform DSTTD systems without SIC. A performance gain of about 0.5 dB is observed for both of the two modulation schemes. In addition, the results presented in this figure show that the analytical expression derived for DSTTD system with SIC is a very tight lower bound compared to the simulation results, and it can accurately predict the error performance of corresponding DSTTD systems.

V. CONCLUSIONS

Theoretical error performance of DSTTD system with optimum combining receiver was investigated in this paper. Spatial multiplexing employed by DSTTD system introduces interferences among transmission antennas. By analyzing the eigenstructure of the interference covariance matrix, we obtained closed-form expressions of the MGF of the post-detection SINR at DSTTD receiver. The results were then used to obtain the exact analytical symbol error rate expressions for linearly modulated DSTTD systems. In addition, a tight lower bound

was derived for DSTTD system with successive interference cancellation. Simulation results show that the analytical results obtained in this paper can accurately predict the performance of DSTTD systems with or without SIC.

APPENDIX: DERIVATION OF (21)

Define $b = \frac{1}{\rho} - s$, then (20) can be written as

$$\begin{aligned} M_\gamma(s) &= \frac{1}{(1-\rho s)^{2N_r-2}} \int_0^{+\infty} \left(1 + \frac{s}{\lambda+b}\right)^2 \frac{\lambda^{2N_r-1}}{\Gamma(2N_r)} e^{-\lambda} d\lambda, \\ &= \frac{1}{(1-\rho s)^{2N_r-2}} \left[1 + 2s \cdot f(2N_r, b) + \right. \\ &\quad \left. s^2 \cdot \int_0^{+\infty} \frac{1}{(\lambda+b)^2} \frac{\lambda^{2N_r-1}}{\Gamma(2N_r)} e^{-\lambda} d\lambda \right], \end{aligned} \quad (27)$$

where the function $f(a, b)$ is defined as

$$f(a, b) = \int_0^{+\infty} \frac{1}{\lambda+b} \frac{\lambda^{a-1}}{\Gamma(a)} e^{-\lambda} d\lambda, \quad (28)$$

and it can be written in closed-form as [16, (3.383.10)]

$$f(a, b) = b^{a-1} e^b \Gamma(1-a, b). \quad (29)$$

The integral in the expression of (27) can be simplified with integration by part, and the result is

$$\begin{aligned} &\int_0^{+\infty} \frac{1}{(\lambda+b)^2} \frac{\lambda^{2N_r-1}}{\Gamma(2N_r)} e^{-\lambda} d\lambda \\ &= -\frac{\lambda^{2N_r-1}}{\Gamma(2N_r)} \frac{e^{-\lambda}}{\lambda+b} \Big|_0^{+\infty} + f(a-1, b) - f(a, b), \\ &= f(a-1, b) - f(a, b). \end{aligned} \quad (30)$$

Replacing (30) into (27) yields

$$M_\gamma(s) = \frac{1}{(1-\rho s)^{2N_r-2}} \left[1 + (2s - s^2) f(2N_r, b) + s^2 f(2N_r - 1, b)\right]. \quad (31)$$

Combining (29) and (31) leads to (21), and this completes the derivation.

REFERENCES

- [1] G. J. Foschini, "Layered space-time architecture for wireless communication in a fading environment when using multiple antennas," *Bell Labs Tech. J.*, vol. 1, pp.41–59, 1996.
- [2] S. M. Alamouti, "A simple transmit diversity technique for wireless communications," *IEEE J. Sel. Area Commun.*, vol. 16, pp. 1451–1458, Oct. 1998.
- [3] V. Tarokh, N. Seshadri, and A. R. Calderbank, "Space-time codes for high data rate wireless communication: performance criterion and code construction," *IEEE Trans. Inf. Theory*, vol. 44, pp. 744–765, Mar. 1998.
- [4] V. Tarokh, H. Jafarkhani, and A. R. Calderbank, "Space-time block codes from orthogonal designs," *IEEE Trans. Inf. Theory*, vol. 45, pp. 1456–1467, July 1999.
- [5] L. Zheng and D. N. C. Tse, "Diversity and multiplexing: a fundamental tradeoff in multiple-antenna channels," *IEEE Trans. Inf. Theory*, vol. 49, pp. 1073–1096, May 2003.
- [6] S. Sfar, L. Dai, and K. B. Letaief, "Optimal diversity-multiplexing tradeoff with group detection for MIMO systems," *IEEE Trans. Commun.*, vol. 53, pp. 1191–1199, July 2005.
- [7] V. Tarokh, A. Naguib, N. Seshadri, and A. R. Calderbank, "Combine array processing and space-time coding," *IEEE Trans. Inf. Theory*, vol. 45, pp. 1121–1128, May 1999.
- [8] N. Prasad and M. K. Varanasi, "Optimum efficiently decodable layered space-time block codes," in *Proc. 35th Asilomar Conference on Signals, Systems and Computers*, vol. 1, pp. 227–231, Nov. 2001.

- [9] L. Dai, S. Sfar, and K. B. Letaief, "Towards a better diversity-multiplexing tradeoff in MIMO systems," in *Proc. IEEE Intern. Conf. Commun. ICC'05*, vol. 4, pp. 2422-2426.
- [10] E. N. Onggosanusi, A. G. Dabak, and T. M. Schmidl, "High rate space-time block coded scheme: performance and improvement in correlated fading channels," in *Proc. Wireless Commun. and Networking Conf. (WCNC'02)*, vol. 1, pp. 194-199.
- [11] S. Shim, K. Kim, and C. Lee, "An efficient antenna shuffling scheme for a DSTTD system," *IEEE Commun. Lett.*, vol. 9, pp. 124-126, Feb. 2005.
- [12] H. Kim, T. Kim, and I. Eo, "Performance analysis of a DSTTD system with decision-feedback detection," in *Proc. IEEE Intern. Conf. Acoustic Speech & Signal Processing ICASSP'06*.
- [13] J. H. Winters, "Optimum combining in digital mobile radio with cochannel interference," *IEEE J. Sel. Areas Commun.*, vol. SAC-2, pp. 528-539, July 1984.
- [14] M. K. Simon and M.-S. Alouini, *Digital Communication over Fading Channels: A Unified Approach to Performance Analysis*. New York: John Wiley & Sons, 2000.
- [15] J. Wu and C. Xiao, "On the error performance of linearly modulated systems with doubly selective Rayleigh fading channels," in *Proc. IEEE Global Telecommun. Conf. GLOBECOM'04*, vol. 1, pp. 308-312.
- [16] I. S. Gradshteyn and I. M. Ryzhik, *Table of Integrals, Series, and Products*, 5th ed. San Diego, CA: Academic, 1994.