

## Estimation of line efficiency by aggregation

***Citation for published version (APA):***

Koster, de, M. B. M. (1987). Estimation of line efficiency by aggregation. *International Journal of Production Research*, 25(4), 615-626.

***Document status and date:***

Published: 01/01/1987

***Document Version:***

Publisher's PDF, also known as Version of Record (includes final page, issue and volume numbers)

***Please check the document version of this publication:***

- A submitted manuscript is the version of the article upon submission and before peer-review. There can be important differences between the submitted version and the official published version of record. People interested in the research are advised to contact the author for the final version of the publication, or visit the DOI to the publisher's website.
- The final author version and the galley proof are versions of the publication after peer review.
- The final published version features the final layout of the paper including the volume, issue and page numbers.

[Link to publication](#)

***General rights***

Copyright and moral rights for the publications made accessible in the public portal are retained by the authors and/or other copyright owners and it is a condition of accessing publications that users recognise and abide by the legal requirements associated with these rights.

- Users may download and print one copy of any publication from the public portal for the purpose of private study or research.
- You may not further distribute the material or use it for any profit-making activity or commercial gain
- You may freely distribute the URL identifying the publication in the public portal.

If the publication is distributed under the terms of Article 25fa of the Dutch Copyright Act, indicated by the "Taverne" license above, please follow below link for the End User Agreement:

[www.tue.nl/taverne](http://www.tue.nl/taverne)

***Take down policy***

If you believe that this document breaches copyright please contact us at:

[openaccess@tue.nl](mailto:openaccess@tue.nl)

providing details and we will investigate your claim.

## Estimation of line efficiency by aggregation†

M. B. M. DE KOSTER‡

In this paper multi-stage flow lines with intermediate buffers are approximated by two-stage lines by using repeated aggregation. The aggregation method uses restricted information of the output pattern of two-stage lines. The method is tested for the case where all production units are unreliable with exponential life- and repair-times. It appears that it performs well for most cases, provided we aggregate in the correct sequence.

### 1. Introduction

An important problem in industrial engineering is the analysis and design of production lines. It is important to balance the subsequent workstations. But even if there is a balance in average, there may be temporary imbalance due to: variations in processing times; unreliability of machines; different products with different capacity requirement profiles over the subsequent stations; and switch-over times.

One way to cope with such uncertainty is by introducing buffers. It is far from easy however to analyse the performance of long lines with several buffers numerically. Therefore, it is necessary to have good approximation methods.

In this paper we consider the problem of approximating the line efficiency of flow lines consisting of several unreliable production units (PUs) separated by buffers. Approximation methods for tandem queues with stochastic service times are well known. See for instance Takahashi *et al.* (1980), Brandwajn and Yow (1985) and Perros and Altiok (1986). A review of such models is given by Perros (1986).

Approximation methods for flow lines with unreliable machines are given by Buzacott (1967), Sheskin (1976) and Ohmi (1981). In all these models the machines index on a common cycle and the operating time has a geometric distribution.

The approximation method we present consists of a repeated aggregation over production units such that the output pattern of the aggregate PU is as close as possible to the pattern of the two buffered PUs. This method is shown in Fig. 1.

Aggregation over production units and an intermediate buffer was used already by Buzacott (1967), who applied it to a fixed cycle three-stage line. Murphy (1978) approximates lines with a continuous goods flow by repeated aggregation over a single buffer and production unit. Repeated aggregation was also used by Suri and Diehl (1986) to approximate the mean sojourn time of a customer in closed queueing networks of finite queues in series, of which the first queue has a capacity larger than the number of customers in the system.

In order to apply an aggregation technique as sketched in Fig. 1, we have to be able to evaluate output parameters for two-stage lines. We assume the PUs to be unreliable with exponentially distributed life- and repair-times. Two-stage lines of

---

Revision received August 1986.

† Research supported by The Netherlands Organization for The Advancement of Pure Research (ZWO).

‡ Eindhoven University of Technology, Department of Industrial Engineering and Management Science, P.O. Box 513, 5600 MB Eindhoven, The Netherlands.

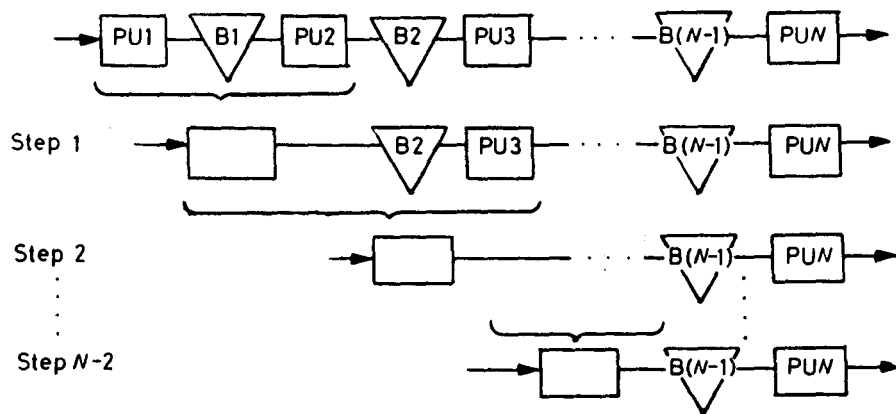

Figure 1. Approximation of a production line by repeated aggregation.

this type can be analysed numerically (see Koenigsberg 1959, Wijngaard 1979, Malathronas *et al.* 1983, De Koster and Wijngaard 1986), indeed, even when the PUs have generally distributed repair-times (Bryant and Murphy 1981). In De Koster (1986) the problem considered is how more general two-stage lines can be approximated by this type of exponential lines.

The aggregate PU is determined to be of the same type as the original PUs.

In §2 we discuss the model and show how variables describing the output behaviour of a two-stage line, such as average downtime, uptime and frequency of downtimes, can be calculated. In §3 we introduce two methods to determine the parameters of the aggregate PUs. In §4 we apply the different aggregation methods on three-stage lines with one or two perfect machines. Such lines have additional advantages since output behaviour of two-stage sublines can be solved analytically. The method which turns out to perform best is applied on more general three-stage lines and on a four-stage line in §5. In §6 some conclusions are drawn.

## 2. The model—description and analysis

The  $N$ -stage line examined in this paper is sketched in Fig. 1. We assume that production is continuous. The production rate of production unit  $i$  ( $PU_i$ ) is  $v_i$  ( $i=1, \dots, N$ ). The PUs are subject to machine failure; the time to the first failure of  $PU_i$  is exponentially distributed with parameter  $\lambda_i$ . Duration of repair is also exponentially distributed, with parameter  $\mu_i$ . We suppose that  $PU_1$  is never starved, that is, it has always items to work on. In a similar way  $PU_N$  is never blocked by lack of storage capacity for finished items.

Now suppose  $PU_i$  is working at rate  $v_i$ , buffer  $(i-1)$  ( $B(i-1)$ ) is empty ( $i=2, \dots, N$ ), then  $PU_i$  has to slow down to the rate at which  $PU(i-1)$  is working, if this rate is smaller than the actual production rate of  $PU_i$ . So if  $PU(i-1)$  is down, then  $PU_i$  is forced down by an empty buffer  $B(i-1)$ . If a buffer is full, the preceding PU may similarly be slowed down or forced down. We assume failures to be time dependent, that is, they occur at the same rate when the station is forced not to run or to run at a lower speed. However it is not difficult to derive similar methods of approximation for operation dependent failures. The capacity of buffer  $B_i$  is  $K_i$ . The throughput of the line is denoted by  $v(\mathbf{K})$ , where

$$\mathbf{K} = (K_1, \dots, K_{N-1})$$

In order to approximate the throughput of such a line we have to be able to characterize the output behaviour of a two-stage line in the same way as an individual PU is characterized. That means that we have to know the average duration of a period with or without output and the frequency of output periods. Therefore an analysis of the two-stage line is needed. This analysis is mainly based on Wijngaard (1979).

The machines of a two-stage line can be in four different machine states, namely:

1. PU1 up, PU2 down
2. PU1 down, PU2 up
3. PU1 down, PU2 down
4. PU1 up, PU2 up

We now distinguish so-called regeneration points, points in time where the process probabilistically restarts itself, for instance an entrance of (2, 0). That is, the machines are in state 2 and the buffer is empty. Note that this regeneration point can be chosen only if  $\lambda_1 \neq 0$ , that is PU1 is not perfect.

The quantities needed in this paper are  $T$ ,  $P$ ,  $S_{v_1}$ ,  $S_{v_2}$ ,  $S_0$  and  $N$  as defined in Table 1; all these quantities may be interpreted as costs per cycle.

Let  $\alpha_i(x)$  be the cost rate in state  $i$  with inventory level  $x \in [0, K]$ , where  $K$  is the buffer capacity, and  $f_i(x)$  the expected cost till the end of the cycle (that is the first entrance of (2, 0)) if we are now in state  $i$ , with inventory level  $x$ . The expected cost per cycle,  $C_T$ , can now be written as

$$C_T = \frac{1}{\lambda_2 + \mu_1} [\alpha_2(0) + \lambda_2 f_3(0) + \mu_1 f_4(0)] \tag{1}$$

and can be obtained by solving the system of first-order linear differential equations for the  $f_i$ 's given by Wijngaard (1979). By substituting the right values for the  $\alpha_i$ 's in this system, all line quantities of Table 1 can be calculated from eqn. (1). The substitutions we have to make in order to obtain these quantities are given in Table 2. In this table  $\delta_{(x)}$ , for some condition  $x$ , stands for

$$\delta_{(x)} = \begin{cases} 1, & \text{if } x \text{ holds} \\ 0, & \text{if } x \text{ does not hold} \end{cases}$$

The calculation of these line quantities is not very time-consuming. Even for relatively large buffer sizes, the CPU time is only about one second on a Burroughs B7900 computer. Note that the throughput of the line with buffer capacity  $K$ ,  $c(K)$ , equals  $P/T$ . Using the same technique it is also possible to obtain second (and higher) moments of the quantities of Table 1 (see Hontelez 1985). Also the probability distribution function of the buffer content can be calculated numerically.

---

$T$	average cycle length
$P$	average production per cycle
$S_v$	average time, per cycle, the line produces at rate $v$
$N$	average number of uptimes (downtimes) per cycle of the line output

---

Table 1. Line quantities.

	$\alpha_1(r)$	$\alpha_2(r)$	$\alpha_3(r)$	$\alpha_4(r)$	$\alpha_1(K)$	$\alpha_2(0)$	$\alpha_3(0)$	$\alpha_3(K)$	$\alpha_4(0)$	$\alpha_4(K)$
$T$	1	1	1	1	1	1	1	1	1	1
$P$	0	$v_2$	0	$v_2$	0	0	0	0	$\min\{v_1, v_2\}$	$v_2$
$S_{v_1}$	0	0	0	0	0	0	0	0	$\delta_{\{v_1 < v_2\}}$	0
$S_{v_2}$	0	1	0	1	0	0	0	0	$\delta_{\{v_2 \leq v_1\}}$	1
$S_0$	1	0	1	0	1	1	1	1	0	0
$N$	$\mu_2$	0	$\mu_2$	0	$\mu_2$	$\mu_1$	0	$\mu_2$	0	0

Table 2. Determination of the line quantities of Table 1.

**3. The approximation method**

In approximating a two-stage line of the type of Fig. 2 we concentrate on two different methods. The parameters of the aggregate PU as implied by the two methods are indicated in Table 3.

For both methods the parameters of the aggregate PU are chosen so that the net production rate of the aggregate PU,  $v\mu/(\lambda + \mu)$  equals  $v(K)$ , the net production rate of the two PUs with intermediate buffer of capacity  $K$ . Furthermore it can easily be checked, using

$$v(K) = \frac{v_1 S_{v_1} + v_2 S_{v_2}}{S_{v_1} + S_{v_2} + S_0}$$

that the machine speeds for methods 1 and 2 are equal. The idea for choosing  $\mu = \mu_2$  in method 1, is that nearly all downtimes of the line are due to a failure of PU2. The choice of  $v$  is evident, whereas the choice of  $\lambda$  is determined by  $\mu$  and  $v$  and the fact that the throughputs have to be equal.

In method 2 the quantity  $1/\lambda$  equals the average lifetime and  $1/\mu$  the average downtime of the line.

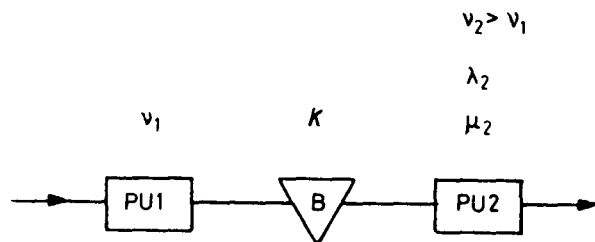

Figure 2. Two-stage line ('type a') with PU1 perfect.

Method	Machine speed	Failure rate	Repair rate
1	$v = \frac{v_1 S_{v_1} + v_2 S_{v_2}}{S_{v_1} + S_{v_2}}$	$\lambda = \frac{\mu(v - v(K))}{v(K)}$	$\mu = \mu_2$
2	$v = \frac{(\lambda + \mu)v(K)}{\mu}$	$\lambda = \frac{N}{S_{v_1} + S_{v_2}}$	$\mu = \frac{N}{S_0}$

Table 3. Two methods for aggregation.

Of course it is possible to approximate the two-stage line by a more complicated PU, with more machine states. We have implemented such a method, but it has appeared that the results do not perform significantly better, whereas the method of approximation is more complicated.

In approximating an  $N$ -stage line we used two different aggregation sequences: from the left and from the right. The approximation from the left is sketched in Fig. 1. Of course we may start the aggregation at any point in the line. In fact there are exactly  $(N - 1)!$  different aggregation sequences.

Note that in the approximation from the right we actually need to know the input-behaviour of a two-stage line instead of the output behaviour. However, since flow lines of the type described in §2 are reversible (that is, reversing the order of the PUs does not change the throughput, see Muth (1979), Wolisz (1984), Yamazaki *et al.* (1985) and De Koster and Wijngaard (1986)), it is not necessary to calculate quantities as in Table 1 for the input of a two-stage line for use in approximations from the right. We may instead aggregate the reversed line from the left.

Relative errors in the approximation are measured in the following way

$$\varepsilon = \frac{v(\mathbf{K}) - v_{\text{ap}}(K)}{v(\infty) - v(\mathbf{K})} \times 100\%$$

where  $v(\infty)$  is the throughput of the line with all buffers of infinite capacity and  $v_{\text{ap}}(K)$  is the throughput of the approximating two-stage line with intermediate buffer of capacity  $K$ . The reason for using this definition of relative error is that we want to take the relative buffer size into account.

In §§ 4 and 5 we will test the methods on several three-stage lines and a four-stage line.

#### 4. Flow lines with perfect machines

In this section we consider three-stage lines with at least one completely reliable PU.

Firstly we suppose PU1 and PU3 are perfect. To avoid trivialities we assume  $v_2 > \max\{v_1, v_3\}$ . It is possible to analyse a line of this type completely in the following three cases:

$$v_1 = v_3 \tag{2 a}$$

$$v_3 < v_1 \quad \text{and} \quad \frac{K_2}{v_2 - v_3} \leq \frac{K_1}{v_2 - v_1} \tag{2 b}$$

$$v_1 < v_3 \quad \text{and} \quad \frac{K_1}{v_2 - v_1} \leq \frac{K_2}{v_2 - v_3} \tag{2 c}$$

In the first case (2a) the line is equivalent with a two-stage line consisting of PU1, B and PU2, only (or PU2, B, PU3) with B a buffer of capacity  $K = \min\{K_1, K_2\}$ . This is proven in De Koster and Wijngaard (1986). In the second case (2b) it can easily be proven that the line is equivalent with a two-stage line consisting of PU2, B2 (with capacity  $K_2$ ) and PU3. The third case (2c) follows from the second one by reversibility. The left sub-line of such a line is called a line of 'type a' and sketched in Fig. 2.

The right sub-line is the reverse of a type a-line as in Fig. 2. For such sub-lines the aggregation methods 1 and 2 appear to coincide. Furthermore the failure rate of the

aggregate PU equals  $\lambda_2$ . Aggregation methods 1 and 2, used from the left, are now tested on the line for which the parameters are given in Table 4.

In Table 5 the throughputs of the line of Table 4 and the approximating line and relative errors are given. These throughputs are obtained analytically as indicated in De Koster and Wijngaard (1986), by using the classification of (2 a-2 c).

From the results in Table 5 we see that the relative errors are quite large (although the approximation as such performs well). We varied the parameters  $\mu_2$ ,  $\lambda_2$ ,  $v_1$ ,  $v_2$ ,  $v_3$  and  $K_1$ ,  $K_2$  and it appears that methods 1 and 2 perform badly if  $v_1 \approx v_3$ ,  $K_1 \leq K_2$  and buffer sizes are large. This is not surprising, since if  $v_1 = v_3$  and  $K_1 \leq K_2$ , we have  $v(K_1, K_2) = v_a(K_1)$ , where  $v_a(K_1)$  is the throughput of line a of Fig. 2. Since in approximating the line, the aggregate PU will sometimes be blocked, we always have  $v_{ap}(K_2) < v(K_1, K_2)$ . If  $v_1 = v_3$  the quantities in buffer B1 and B2 are completely negatively correlated. In case  $K_1 = K_2$ , B1 is empty if and only if B2 is full (see De Koster and Wijngaard 1986). Buffer correlation is not taken into account in any of such aggregation heuristics.

We now compare the methods for a line with only one perfect machine and  $K_1 = K_2$ . The parameters of the line are given in Table 6. This line is approximated by aggregating from the left and from the right. Since the left sub-line is of type a, methods 1 and 2 coincide in aggregation from the left. The parameters of the aggregate PU are given, for  $K_1 = 10, 20, 30$ , in Table 5.

	Machine speed	Failure rate	Repair rate	Net machine speed
PU1	$v_1 = 1.0$	$\lambda_1 = 0$	—	1.0
PU2	$v_2 = 1.05$	$\lambda_2 = 0.01$	$\mu_2 = 0.07$	0.919
PU3	$v_3 = 1.01$	$\lambda_3 = 0$	—	1.01

Table 4. Three-stage line with two perfect PUs.

$K_1$	$K_2$	$v(K_1, K_2)$	$v$	$v_{ap}(K_2)$	$\epsilon$
10	10	0.9102	1.04021	0.9086	18.08
20	20	0.9166	1.04752	0.9161	21.81
30	30	0.9182	1.04934	0.9181	16.85
$\infty$	$\infty$	0.91875	—	—	—

Table 5. Relative errors in approximations from the left.

	Machine speed	Failure rate	Repair rate	Net machine speed
PU1	$v_1 = 1.0$	$\lambda_1 = 0$	—	1.0
PU2	$v_2 = 1.05$	$\lambda_2 = 0.01$	$\mu_2 = 0.07$	0.919
PU3	$v_3 = 1.0$	$\lambda_3 = 0.01$	$\mu_3 = 0.07$	0.875

Table 6. Three-stage line with one perfect PU.

In Tables 7 and 8, line output and relative errors are given in approximations from the left and from the right, respectively. Note that in aggregation from the right, methods 1 and 2 are not identical. The throughput of the line is obtained by simulation. We used 50 runs of 100 000 units of time each. From Table 8 we see that methods 1 and 2 perform equally well for this line and comparing it with Table 7 we see that it does not matter much from which side we start the aggregation.

Although this case suggests that methods 1 and 2 do not differ much, it has appeared that often method 2 performs slightly better. Therefore, in § 5 only method 2 is used.

**5. Lines with unreliable machines only**

In this section we test method 2 for three different lines. The characteristics of all lines are given in Table 9. The first line is a rather balanced line, whereas the second line is unbalanced. PU1 and PU2 are bottlenecks. The third line is a four-stage line. For the first and second line the total buffer size  $C=20$ , for the third line  $C=30$ . All lines were simulated 50 times, 100 000 units of time for each run and then approximated from the left and from the right by method 2. The results for the first line are listed in Table 10.

From the results of Table 10, we see that it is important to start aggregating from the right direction. It seems that it is right to start on the side with the smallest buffer, but a heuristic which often performs better is:

*Heuristic 1.* Calculate  $v_{ap}(K_2)$  and  $v_{ap}(K_1)$ . If  $v_{ap}(K_2) \geq v_{ap}(K_1)$  then aggregation from the left performs best, otherwise aggregation from the right performs best.

This heuristic may be clarified partly by considering the line of Table 4. Buffers preceding and succeeding a PU are often negatively correlated, which implies that the approximated throughput is too small. Therefore we have to take the maximum approximation.

Considering the results it is best to start aggregating on the side of the smallest buffer for a three-stage line consisting of identical PUs. This can be seen in the following way. In the first step then, we slightly over-estimate the line throughput and in the second step a small downward correction is applied, whereas for the other

$K_1$	$K_2$	$v(K_1, K_2)$	Method 1/2	
			$v_{ap}(K_2)$	$\epsilon$
0.01	0.01	0.7656	0.7657	-0.10
5	5	0.7918	0.7897	2.49
10	10	0.8071	0.8060	1.64
20	20	0.8265	0.8266	-0.14
30	30	0.8385	0.8389	-1.20
40	40	0.8466	0.8471	-1.88
50	50	0.8524	0.8529	-2.33
60	60	0.8566	0.8572	-3.31
$\infty$	$\infty$	0.875	—	—

Table 7. Relative errors in approximations of the line of Table 6 from the left.



$K_1$	$K_2$	$r(K_1, K_2)$	1/2		1		2			
			$r$	$\lambda$	$r_{\text{ap}}(K_1)$	$\varepsilon$	$\lambda$	$\mu$	$r_{\text{ap}}(K_1)$	$\varepsilon$
0.01	0.01	0.7656	1.00010	0.0214	0.7657	-0.09	0.0207	0.0677	0.7657	-0.09
5	5	0.7918	1.02139	0.0203	0.7920	-0.24	0.0196	0.0678	0.7920	-0.24
10	10	0.8071	1.02645	0.0190	0.8075	-0.59	0.0184	0.0679	0.8075	-0.59
20	20	0.8265	1.03109	0.0173	0.8270	-1.03	0.0168	0.0682	0.8270	-1.03
30	30	0.8385	1.03368	0.0162	0.8391	-1.64	0.0159	0.0683	0.8391	-1.64
40	40	0.8466	1.03553	0.0156	0.8472	-2.11	0.0152	0.0684	0.8472	-2.11
50	50	0.8524	1.03677	0.0151	0.8529	-2.21	0.0148	0.0685	0.8529	-2.21
60	60	0.8566	1.03768	0.0147	0.8572	-3.26	0.0144	0.0686	0.8572	-3.26
$\infty$	$\infty$	0.875	—	—	—	—	—	—	—	—

Table 8. Relative errors in approximations of the line of Table 6 from the right.

1	Machine speed	Failure rate	Repair rate	Net production speed
PU1	0.9	0.01	0.35	0.875
PU2	1.05	0.01	0.07	0.919
PU3	1.0	0.01	0.07	0.875
2				
PU1	1.0	0.01	0.015	0.6
PU2	1.0	0.01	0.07	0.875
PU3	0.67	0.01	0.09	0.6
3				
PU1	1.0	0.01	0.03	0.750
PU2	1.0	0.01	0.07	0.875
PU3	1.05	0.01	0.07	0.919
PU4	0.9	0.01	0.35	0.875

Table 9. Parameters of three different lines.

$K_1$	$K_2$	$v(K_1, K_2)$	Left		Right	
			$v_{ap}(K_2)$	$\epsilon$	$v_{ap}(K_1)$	$\epsilon$
2	18	0.7488	0.7470	1.43	0.7223	21.00
5	15	0.7607	0.7552	4.81	0.7420	16.36
8	12	0.7671	0.7584	8.06	0.7539	12.23
10	10	0.7691	0.7584	10.10	0.7588	9.73
12	8	0.7696	0.7569	12.05	0.7619	7.31
15	5	0.7678	0.7519	14.83	0.7632	4.29
18	2	0.7620	0.7432	16.64	0.7603	1.50
$\infty$	$\infty$	0.875	—	—	—	—

Table 10. Errors in approximations of the first line of Table 9.

approximation sequence in the first step a 'large' over-estimation is adjusted by a 'large' correction in the second step (even larger because of correlation), therefore  $v_{ap}(K_2) \geq v_{ap}(K_1)$ . Approximation from the left will be better since small corrections are better than large ones. For the particular line here, heuristic 1 states: for  $K_1 \leq 8$  (hence  $K_2 \geq 12$ ) aggregation from the left performs best, which is approximately correct in this case.

In table 11 the results are listed for approximations of the second line by aggregating from the left and from the right, respectively. The approximation from the left performs best for  $K_1 \leq 12$  (hence  $K_2 \geq 8$ ). That means that the heuristic indeed prescribes the best of the two approximations. Notice, however, that relative errors are large in absolute values for extreme buffer allocations.

The last example of this section is the four-stage line described in Table 9. This line was approximated by aggregating in three different ways. Firstly by aggregating from the left to the right, secondly from the right to the left, and thirdly by aggregating PU1, B1, PU2 and PU3, B3, PU4. This last method is made clear in

$K_1$	$K_2$	$c(K_1, K_2)$	Left			Right	
			$v_{ap}(K_2)$	$\epsilon$	$v_{ap}(K_1)$	$\epsilon$	
2	18	0.4134	0.4244	-5.89	0.3631	26.96	
5	15	0.4142	0.4186	-2.37	0.3752	20.99	
8	12	0.4139	0.4103	1.93	0.3846	15.74	
10	10	0.4129	0.4033	5.13	0.3894	12.56	
12	8	0.4111	0.3948	8.63	0.3931	9.53	
15	5	0.4066	0.3787	14.43	0.3961	5.43	
18	2	0.3986	0.3577	20.31	0.3953	1.64	
$\infty$	$\infty$	0.6	—	—	—	—	

Table 11. Errors in approximations of the second line of Table 9.

Fig. 3. Note that here we actually need the input behaviour of PU3, B3 and PU4. Results of the approximations are listed in Table 12.

We may generalize heuristic 1 in a straightforward way and then we see once more that aggregation from the left performs best, according to this new heuristic, for  $K_1 \leq 12$ , compared with approximation from the right. Approximation 3 generally does not perform much better than the heuristic combination of 1 and 2.

## 6. Conclusions

The throughput of three-stage flow lines with continuous goods flow, exponential life- and repair-times for each PU and intermediate buffers can be very well approximated by a simple two-stage line by aggregating over the PUs. The aggregation steps are computationally simple and the total approximation requires,

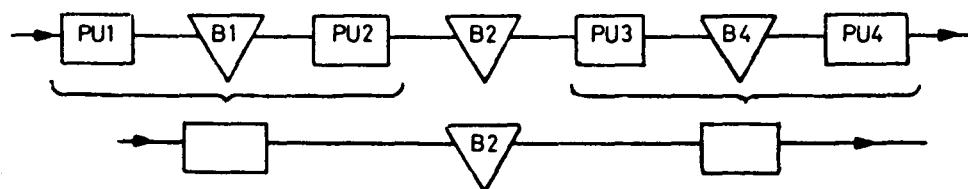

Figure 3. Third way of aggregating as used for Table 12.

$K_1$	$K_2$	$K_3$	$c(K_1, K_2, K_3)$	1		2		3	
				$v_{ap}(K_3)$	$\epsilon$	$v_{ap}(K_1)$	$\epsilon$	$v_{ap}(K_2)$	$\epsilon$
2	10	18	0.6195	0.6140	4.21	0.5898	22.76	0.6066	9.89
5	10	15	0.6284	0.6192	7.57	0.6002	23.19	0.6125	13.08
8	10	12	0.6349	0.6212	14.90	0.6083	26.40	0.6165	19.09
10	10	10	0.6379	0.6204	15.61	0.6123	22.84	0.6180	17.75
12	10	8	0.6397	0.6176	20.04	0.6153	22.12	0.6185	19.22
15	10	5	0.6394	0.6080	28.39	0.6176	19.71	0.6172	20.07
18	10	2	0.6340	0.5879	39.74	0.6164	15.17	0.6123	18.71
$\infty$	$\infty$	$\infty$	0.750	—	—	—	—	—	—

Table 12. Approximation of the third line of Table 9.

for an  $N$ -stage line only about  $N$  seconds of CPU time on the Burroughs B7900 computer. In general we can say that the aggregation method performs better when the PUs are more balanced. The order in which the aggregation is carried out is of crucial importance for the quality of the resulting approximation. We have stated a heuristic to obtain the best approximation.

For four-stage lines the heuristic is applicable as well. However, other sequences of aggregation may also perform well. When more sequences of aggregation are evaluated we suggest the following heuristic.

*Heuristic 2.* Evaluate  $v_{ap}(K)$  for all aggregation sequences taken into account. Then the best aggregation sequence is that sequence for which  $v_{ap}(K)$  is maximum.

This heuristic is supported by the results of Table 12. We have not investigated longer lines, but as we compare Tables 10 and 12 we may conclude that the approximation will not become much worse when more PUs are involved which are not too unbalanced.

### Acknowledgments

The author is grateful to J. Wijngaard and A. Agasi for valuable suggestions in this study.

Dans cet article, des lignes de déroulement en plusieurs étapes à écarts intermédiaires sont approchées par des lignes à deux étapes au moyen d'une agrégation répétée. Le procédé d'agrégation utilise les informations restreintes du schéma de production des lignes à deux étapes. Le procédé est éprouvé en fonction de situations où toutes les unités de production seraient non-fiables avec temps de longévité et de réparation exponentiels. Ce modèle semble être performant dans la plupart des situations à condition que l'agrégation s'effectue dans la séquence correcte.

In dieser Abhandlung werden mehrstufige Fließbänder mit Zwischenwerkstückspeichern durch zweistufige Fließbänder mit Hilfe wiederholter Gruppierungen angenähert. Die Gruppierungsmethode verwendet begrenzte Informationen über das Ausgabe-Produktionsprofil zweistufiger Fließbänder. Die Methode wird für den Fall getestet, wo alle technologischen Einheiten unzuverlässig sind und exponentielle Betriebslebensdauer und Reparaturzeiten haben. Es hat den Anschein, als ob die Methode sich in den meisten Fällen bewährt, vorausgesetzt, die Gruppierung erfolgt in der richtigen Reihenfolge.

### References

- BRANDWAJN, A., and YOW, Y. L., 1985, An approximation method for tandem queues with blocking. Amdahl Corporation Technical Report.
- BRYANT, J. L., and MURPHY, R. A., 1981, Availability characteristics of an unbalanced buffered series production system with repair priority. *A.I.I.E. Transactions*, **13**, 249-257.
- BUZACOTT, J. A., 1967, Automatic transfer lines with buffer stocks. *International Journal of Production Research*, **5**, 183-200.
- DE KOSTER, M. B. M., 1986, Capacity analysis of two-stage production lines with many products. Paper presented at the Fourth International Working Seminar on Production Economics, Igls, Austria.
- DE KOSTER, M. B. M., and WIJNGAARD, J., 1986, A continuous flow model for three production units in series with buffers. *Operations Research Proceedings DGOR* (Berlin: Springer Verlag), pp. 253-264.

- HONTELEZ, J., 1985, Design and modelling of production lines. Master's thesis (in Dutch), Eindhoven University of Technology, The Netherlands.
- KOENIGSBERG, E., 1959, Production lines and internal storage—a review. *Management Science*, **5**, 410–433.
- MALATHRONAS, J. P., PERKINS, J. D., and SMITH, R. L., 1983, The availability of a system of two unreliable machines connected by an intermediate storage tank. *I.I.E. Transactions*, **15**, 195–201.
- MURPHY, R. A., 1978, Estimating the output of a series production system. *A.I.I.E. Transactions*, **10**, 139–148.
- MUTH, E. J., 1979, The reversibility property of production lines. *Management Science*, **25**, 152–158.
- OHMI, T., 1981, An approximation for the production efficiency of automatic transfer lines with in-process storages. *A.I.I.E. Transactions*, **13**, 22–28.
- PERROS, H. G., 1986, A survey of queuing networks with blocking—part I, Computer Science Report, North Carolina State University, U.S.A.
- PERROS, H. G., and ALTIOK, T., 1986, Approximate analysis of open queuing networks with blocking: tandem configurations. *I.E.E.E. Transactions on Software Engineering*, **12**, 450–461.
- SHESKIN, T. J., 1976, Allocation of interstage storage along an automatic production line. *A.I.I.E. Transactions*, **18**, 146–152.
- SURI, R., and DIEHL, G. W., 1986, A variable buffer-size model and its use in analyzing queuing networks with blocking. *Management Science*, **32**, 206–224.
- TAKAHASHI, Y., MIYAHARA, H., and HASEGAWA, T., 1980, An approximate method for open restricted queuing networks. *Operations Research*, **28**, 594–602.
- YAMAZAKI, G., KAWASHIMA, T., and SAKASEGAWA, H., 1985, Reversibility of tandem blocking queuing systems. *Management Science*, **31**, 78–83.
- WIJNGAARD, J., 1979, The effect of interstage buffer storage on the output of two unreliable production units in series, with different production rates. *A.I.I.E. Transactions*, **11**, 42–47.
- WOLISZ, A., 1984, Production rate optimization in a two-stage system with finite intermediate storage. *European Journal of Operational Research*, **18**, 369–376.