

## Estimation of shear force for blind shear ram blowout preventers

Abdulkadir Tekin\*, Changhyok Choi, Taylan Altan, Hamit Adin

Online Publication Date: 17 Feb 2015

URL: <http://www.jresm.org/archive/resm2014.02st1225.html>

DOI: <http://dx.doi.org/10.17515/resm2014.02st1225>

Journal Abbreviation: *Res. Eng. Struct. Mat.*

### To cite this article

Tekin A, Choi C, Altan T, Adin H. Estimation of shear force for blind shear ram blowout preventers. *Res. Eng. Struct. Mat.*, 2015; 1: 39-51.

### Disclaimer

All the opinions and statements expressed in the papers are on the responsibility of author(s) and are not to be regarded as those of the journal of Research on Engineering Structures and Materials (RESM) organization or related parties. The publishers make no warranty, explicit or implied, or make any representation with respect to the contents of any article will be complete or accurate or up to date. The accuracy of any instructions, equations, or other information should be independently verified. The publisher and related parties shall not be liable for any loss, actions, claims, proceedings, demand or costs or damages whatsoever or howsoever caused arising directly or indirectly in connection with use of the information given in the journal or related means.



Research Article

## Estimation of shear force for blind shear ram blowout preventers

Abdulkadir Tekin<sup>\*1</sup>, Changhyok Choi<sup>1</sup>, Taylan Altan<sup>1</sup>, Hamit Adin<sup>2</sup>

<sup>1</sup>Department of Mechanical Engineering, Ohio State University, Engineering Research Center, U.S.A.

<sup>2</sup>Department of Mechanical Engineering, Batman University, Batman, Turkey

### Article Info

#### Article history:

Received 25 Dec 2014

Revised 11 Feb 2015

Accepted 13 Feb 2015

#### Keywords:

Design management,  
Geometric modeling,  
Engineering analysis,  
Finite Element Method

### Abstract

In this study, the estimation of shear force for blind shear ram type blowout preventer was investigated by using Finite Element Method (FEM). So, the effect of the blowout preventer working condition on shear force requirement for shear operation could be accurately approximated by simulating the entire process, and ram geometry could be optimized to reduce force and energy used to shear the tube by plastic deformation. The results of FEM analyzes was compared with blowout preventer manufacturer shear force information. Comparisons show that forces evaluated by using FEM (Deform 3D) simulations provided fairly accurate results for actual shear force. Also, it was found that by using Finite Element simulations the effect of the blowout preventer working condition on shearing operation can be estimated and ram geometries can be optimized. Therefore, FEM analyses could be used to design more reliable and efficient ram type blowout preventers.

© 2015 MIM Research Group. All rights reserved.

## 1. Introduction

During drilling operations, all formations' high pressure fluids and gases of the earth are controlled by borehole pressure, which consists of hydrostatic pressure of drilling mud, pump pressure, and friction pressure loss in the annulus. If, for any reason, the borehole pressure falls below the formation fluid/gas pressure, the formation fluids/gases will enter the hole and a pressure "kick" will occur. If a kick cannot be controlled properly, uncontrolled formation fluids/gases will reach to surface where the drilling rig is located. Such a catastrophic event is known as blowout [1].

To prevent formation fluids/gases to reach the surface of the well, blowout preventers are used as safety valves. When they are activated, they are supposed to close off the wellbore and seal it (in some cases, the sealing pressures are 20,000 Psi which is 1360 bar) in an emergency to control and balanced formation fluids and gases [2].

In a blowout preventer stack, two types of blowout preventers are used; annular and ram. Annular BOPs are used in combination with hydraulic system that can seal off different sizes of annulus whether drill pipe is in use in the wellbore or not. Upon command, high-pressure fluid is directed to the closing hydraulic ports positioned in the lower side of the piston. This causes the operating piston to move upward; therefore, the moving piston compresses the packer [3]. Because of a cap at the top of annular blowout preventer, the

\*Corresponding author: [tekin.3@osu.edu](mailto:tekin.3@osu.edu)

DOI: <http://dx.doi.org/10.17515/resm2014.02st1225>

Res. Eng. Struct. Mat. Vol. 1 Iss.1 (2015) 39-51

packer can only move toward the center of the wellbore to pack off a drill pipe or seal off the wellbore.

Ram BOPs, except for using a pair of opposing steel rams, they are similar to a gate valve in operation. When they are activated, the rams are pulled toward the center of the wellbore to close and seal the hole. Pipe ram BOPs seal around the pipe, blind ram BOPs seal across the open hole when there is not any tubing in the hole, and blind shear ram BOPs, which is the last line of defense against blowout, cuts through the drill string and effectively seals the borehole.

According to a recent report prepared for the U.S. Minerals Management Services (MMS), two of the three blind shear ram BOP manufacturers rely on a very basic equation “the Distortion Energy Theory shear equation” to estimate the shear force requirement for shearing operation [4]. However, with recent advancement in drill pipe materials, it might not be sufficient to estimate the actual shear force to shear a specific drill pipe using yield or tensile stress alone and the Distortion Energy Theory shear equation. Therefore, the shear ram blowout preventers with traditional design might not work properly when they are needed.

Several reports have been published investigating the reliability of both surface and subsea BOP equipment. One of them was done in Norway by the Foundation for Scientific & Industrial Research at the Norwegian Institute of Technology [5]. During his study, Holland observed a total of 117 failures 11 of which were observed from ram type blowout preventers. Also he indicated that two ram type blowout preventers that were relatively new designs, failed far more frequently than older types of ram preventers.

Another important study about reliability of BOP stack was conducted by Childs [6]. Childs had experience with 14 blowout preventers that were manufactured by two major BOP manufacturers. Seven of the 14 blowout preventers were tested to confirm shear ram capabilities. Five of the rig’s blowout preventers passed and two failed to shear the pipe on the surface (without hydrostatic pressures of the borehole considered). When the supplementary effect of hydrostatic pressure of borehole is added to the surface shearing pressure, six of the rig’s blowout preventers were able to be tested and three of the six passed in this case.

Although one single failure of a blowout preventer might cause disaster in terms of injury, the environment and the economy, researchers have found in some cases half of the tested blowout preventers are not able to secure the well in an emergency situation. These studies illustrate the lack of preparedness in the industry for drill pipe shear in the well and seal the borehole as the last line of defense against a blowout.

Using finite element method to analyze the drill pipe materials and dimensions and simulate the entire shearing and sealing operation with blowout preventer working conditions through the finite element simulation can provide good approximation for actual shear force and sealing pressure to secure the well. Also, the finite element method can be used to optimize shear ram geometry so that minimum force and energy can be used to shear the tube by plastic deformation [7].

Three task studies are presented throughout this research. The first two tasks were studied to develop a methodology to evaluate the required shear force for a certain drill pipe shear without considering the effect of blowout preventer working conditions on shearing operation [8]. To justify the methodology, the results of these studies were compared with experimental shear forces obtained from the three major blowout preventer manufacturers, Cameron, Hydril, and Varco [9]. Task 3 was studied to evaluate the effect of the vertical load stemming from the weight of drill string on shear force requirement.

## 2. The Effect of Factors on Shear Force

The Distortion Energy Theory shear equation might not be sufficient with newly-developed drill pipes that have highly advanced material properties. Beside material properties, there will be some other factors for which contributions to the required shear force to shear a specific drill pipe could be significant. Therefore, they should be considered during evaluation of required shear force.

### 2.1. Temperature Gradient

In the offshore drilling operation, subsea blowout preventer is placed on the seabed; and seawater temperature at this depth might be around 3-5°C, while the formation fluid temperature that flows through the wellbore in case of blowout could be higher than 150°C. Therefore, the temperature difference between seawater that enclosed the BOP stuck and formation fluid could be significant when the blind shear ram is activated (Fig 1). This temperature difference will cause the material properties to change and create a thermal stress on the pipe and shear ram as well. As a result, there will be some differences in the shear force requirement for shearing operation which should be taken into account in evaluation of the actual shear force.

### 2.2. Pressure Gradient

If the hydrostatic pressure of the wellbore falls below the formation fluid pressure, formation fluid begins to flow through the wellbore to the surface with a flow rate that is determined by pressure gradient. Because of the high formation fluid pressure (in some cases it might be more than 20,000 Psi [5]), the pressure gradient can be very high to cause a pressure shock on the blind shear ram when it begins to close the wellbore. This pressure shock creates some forces on shearing direction (x) and (y) direction as well depending on the shape of the blind shear ram (Fig 1). The contribution of these forces to the required shear force is significant and thus they should be considered as supplementary forces for the shearing operation.

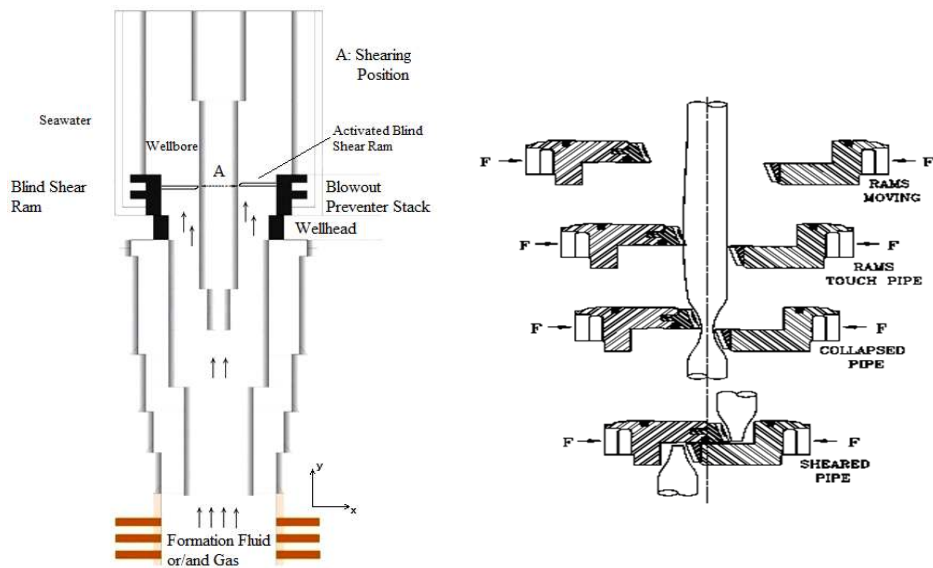

Fig. 1 Activated blind shear ram and shear sequence [5]

The contribution of y direction force to the required shear force is limited relative to the x direction force during the shearing operation. But once the blind shear ram cuts the drill pipe successfully, it needs to seal the wellbore against the formation fluid pressure. This means that the blind shear ram must remain stable under y direction force that is created by formation fluid pressure.

### 2.3 Loads on the Shearing Position

During drilling operation, the weight of the drill string is supported by the hoisting equipment (traveling block – hook) and bit weight is adjusted by the weight gauge that shows the load on the bit with other complementary equipment. Except some part of drill string above the drill bit, drill string is under tension load during the drilling operation. Once formation fluid begins to enter the wellbore, it creates some forces in y direction, which pushes the drill string upward. Therefore, axial tension load decreases gradually while compression force is increasing (Fig 1). As a result, when blowout preventer is activated higher shear force will require the drill pipe to shear if there is compression load on the shearing position. This phenomenon is studied in Task 3.

### 2.4 Shear Ram Velocity

The shearing operation occurs in a very short time because of high velocity of the shear rams. Thus, the real time properties of drill pipe changes during the shearing operation depending on the ram velocity. Changing drill pipe properties might cause the required shear force to increase. Therefore, the effect of the shear ram velocity on the shearing operation should be considered in evaluation of required shear force.

### 2.5 Tool Joints Area

The ends of drill pipe joints are called tool joints. One end of a length of drill pipe is screwed on the male section and the other end is screwed on the female section, so diameter and thickness of the tool joints area are greater than that of drill pipe body. To provide numerous cycles of tightening and loosening, tool joints have also been manufactured separately from the pipe body and welded onto the pipe that are made of steel; and have been treated by heat to a higher strength than the steel pipe body.

Therefore, if the shear rams attempt to cut the tool joints area, process might not be successful unless shear ram has been designed according to tool joint material properties since required shear force to cut the tool joint area is much higher than the drill pipe body.

Generally, shear ram types BOPs are designed to shear drill pipe in the second attempt by changing drill pipe position (moving drill string upward or down) in the blowout preventer if the first attempt is on the tool joint area and unsuccessful. However, the first unsuccessful attempt might result in some damage to the shear ram that will cause the require shear force for the second attempt to become higher. Thus, the effect of the first unsuccessful attempt should be considered as a supplementary force for the shearing operation.

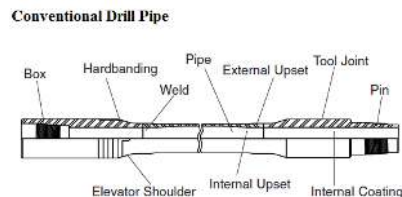

Fig. 2. Drill pipe tool joint

### 3. Modelling Procedure

Throughout this study, FEM (Deform 3D) is used as a tool to determine required shear force to shear a specific drill pipe and evaluate the effect of weight of drill string on the shearing operation.

#### 3.1 Shear Ram and Drill Pipe Geometries

Shear ram and drill pipe geometries are presented in Fig 3 and drill pipe dimensions are presented in Table. 1.

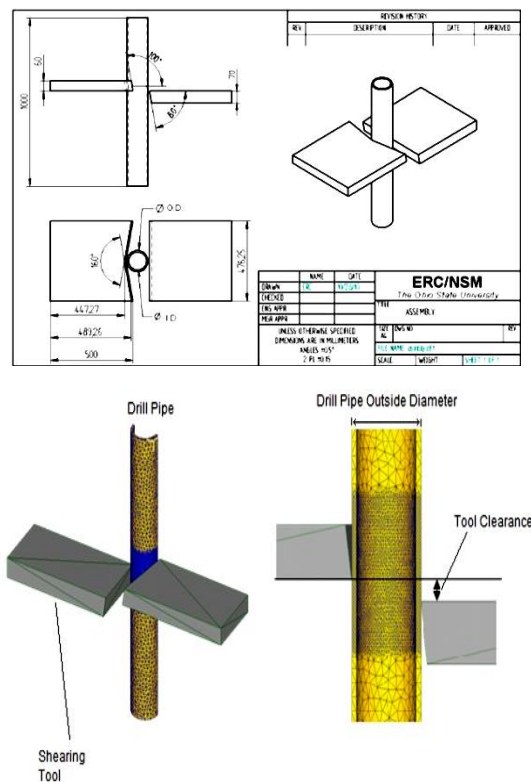

Fig. 3. The geometries of shear ram and drill pipe

Table 1 Drill pipe dimensions and properties [4]

#	Material	Dimensions		Thickness (mm)	Area (cm <sup>2</sup> )	Weight/length ratio (kg/m)	Yield strength (MPa)	Ultimate tensile strength (MPa)	Elong %
		O.D. (mm)	I.D. (mm)						
110	S-135	5" (127)	108.61	9.195	34.03	29.02	1014.22	1099.71	23.1
135	S-135	5.5" (139.7)	121.30	9.169	37.60	32.59	1052.83	1101.78	20.0

### 3.2 Drill Pipe Properties

Two kinds of drill pipe were used to develop a methodology for a simple shearing operation, in which the effect of the environment on shearing operations was not considered. The drill pipe properties are presented in the Table 1.

Since the original flow stress curve of materials was not available, it was approximated by using the equation:

$$Y_f = K\varepsilon^n \quad (1)$$

where,  $Y_f$ : Flow stress,  $\varepsilon$ : True strain,  $K$ : Strength coefficient,  $n$ : Strain hardening exponent [10].

Estimated flow stress curves are presented in Fig 4. As can be seen in Fig 4, true stress of material changes significantly within 0 - 0.2 mm/mm of plastic strain then there appear very small changes in true stress; therefore, any flow stress error after 0.2 mm/mm of plastic strain does not significantly change the results.

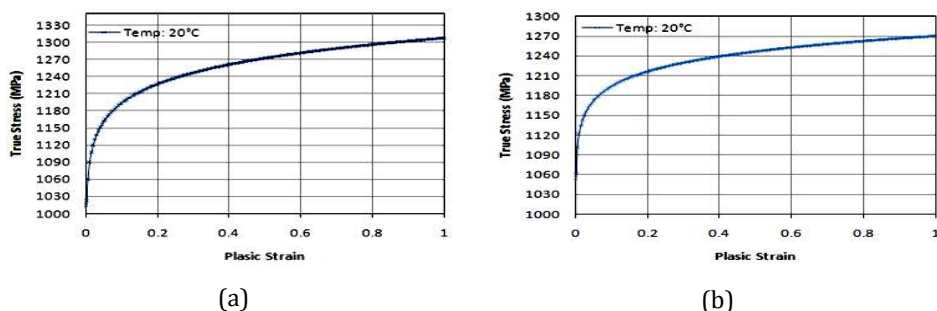

Fig. 4. Estimated flow stress curves of drill pipes (a) 5'' o.d. drill pipe flow stress curve, (b) 5.5'' o.d. drill pipe flow stress curve

### 3.3 Friction Factor and Mesh Condition

Constant shear friction is used as a friction theory. The friction factor was taken as 0.12 since it is the average friction factor for stainless steel.

- Two types of mesh conditions were used;
- On the shearing position
  - Tetrahedral mesh
  - 3.5 mm element size
- Other position
  - Tetrahedral mesh
  - 10 mm element size

As can be seen in Fig. 5, to get more accurate result, element size on effective shearing position was used as 3.5 mm, but to reduce simulation running time, 10 mm element size was used on the other positions.

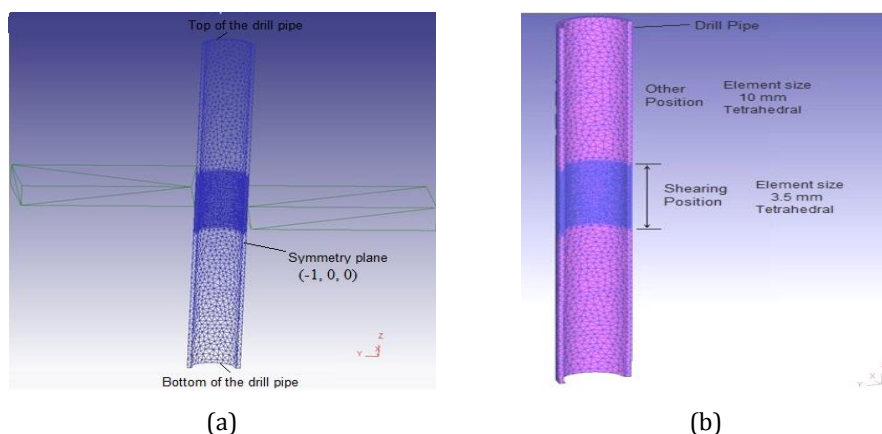

Fig. 5. Mesh of drill pipe; (a) boundary conditions, (b) mesh details

## 4. Results and Discussions

### 4.1 Task 1 and Task 2

The simulation parameters of Task 1 and Task 2 are shown in Table 2.

Table 2 Simulation parameters for Task 1 and Task 2

	Task 1	Task 2
Drill pipe outside diameter	5" (127 mm)	5.5" (139.7 mm)
Drill pipe thickness	0.362 in. (9.19 mm)	0.361 in. (9.17 mm)
Area	5.27 in. <sup>2</sup> (34.03 cm <sup>2</sup> )	5.83 in. <sup>2</sup> (37.60 cm <sup>2</sup> )
Yield strength (MPa)	1014.219	1052.829
UTS (MPa)	1099.714	1101.782
Elongation (%)	23.1	20
Load on shearing position	0 (ton)	

Boundary conditions:

As their applied position is showed in Fig 5, two kinds of boundary conditions were applied in two categories to get accurate results.

1. Step 1 to 50
  - Top of the drill pipe: X, Y fixed
  - Bottom of the drill pipe: X, Y, Z fixed
  - Symmetry plane (-1,0,0)
2. Step 51 to 1062
  - Top of the drill pipe: X, Y fixed
  - Bottom of the drill pipe: X, Y fixed
  - Symmetry plane (-1,0,0)

The simulation results showed that for Task 1 the maximum shear force (1193 kN) occurred at a stroke of 54 mm for both rams, which meant 108 mm total stroke and for Task 2 the maximum shear force (1197 kN) occurred at 120 mm total stroke (Fig 9).



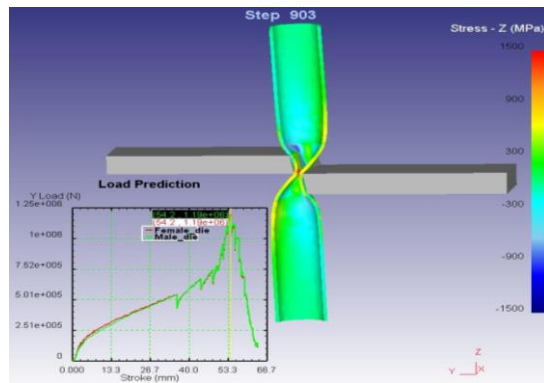

(a)

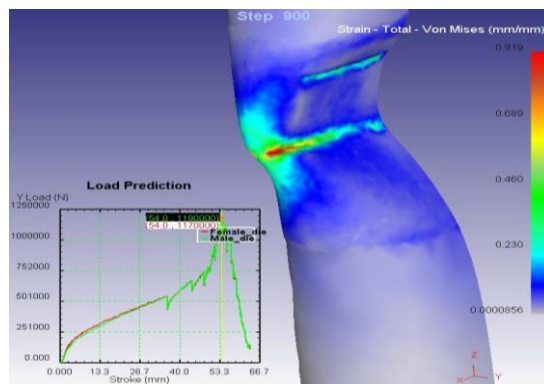

(b)

Fig. 6. Obtained maximum (a) shear force and (b) strain

To determine maximum true strain when the maximum shear force occurred, it is necessary to evaluate the effective range of true strain because the maximum true strain might change significantly depending on one single element and this can cause misestimating. However, the effective range does not change significantly. Therefore, throughout this study the effective range for true strain is evaluated as 99% of element number and maximum strain is obtained from this range. For instance, as can be seen in Fig7 for Task 1, only one single element has strain range of 0.91894-2.45037. According to this estimation the maximum true strain is 2.45037, but the effective strain range is from 0 to 0.45951 since 99% of total elements are 14510 (13090 + 1028 + 257 + 135 = 14510) within this range. Therefore, for Task 1, the maximum true strain is 0.45951 mm/mm. In Task 2, evaluated maximum true strain is 0.47 mm/mm.

As it was mentioned before, the first two tasks were studied to determine a methodology that could provide good approximation for the actual shear force. Thus, the evaluated shear forces by using Finite Element analyses, the calculated shear forces by using Distortion Energy Theory shear equation and the actual shear forces obtained from the BOP manufacturers are compared in Table 3 and presented graphically in Fig 8.

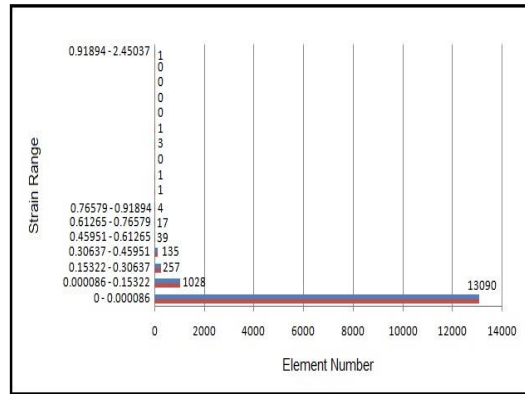

Fig. 7. Evaluation of maximum strain

Table 3 Shear force comparison

#	O.D. (mm)	Pipe area (cm <sup>2</sup> )	Actual shear force [4] (kN)	Calculated shear force using distortion theory equation (kN)		Obtained shear force from F.E.M. (Deform 3D) (kN)
				Using yield strength (MPa)	Using ultimate tensile strength (MPa)	
110	5" (127)	34.03	1177	1991	2159	1193
135	5.5" (139.7)	37.60	1472	2284	2390	1197

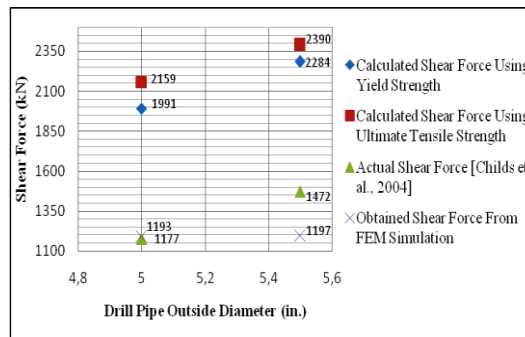

Fig. 8. Shear force comparisons

### 4.2. Task 3

This task was studied to evaluate the possible effect of vertical load, which comes from the weight of drill string, on shear force requirement to shear 5.5 inch diameter drill pipe.

It should be noted that the drill pipe, which is on shearing position, is the same as the drill pipe used in Task 2. Thus, the maximum shear force for simple shearing for this drill pipe has already been studied. Simulation parameters for Task 3 are presented in Table 4. To determine the possible effect of the drill string weight on required shear force, a well

configuration that is shown in Fig 9 was taken as a sample; and the drill pipe properties that are used in well are presented in Table 5.

Table 4 Simulation parameters for Task 3

Drill pipe outside diameter	5.5" (139.7 mm)
Drill Pipe Thickness	0.361 in. (9.17 mm)
Area	5.82 in. <sup>2</sup> (37.60 cm <sup>2</sup> )
Drill pipe material properties	#135 (see Table 4)
Load on shearing position	47.74 ton compression load

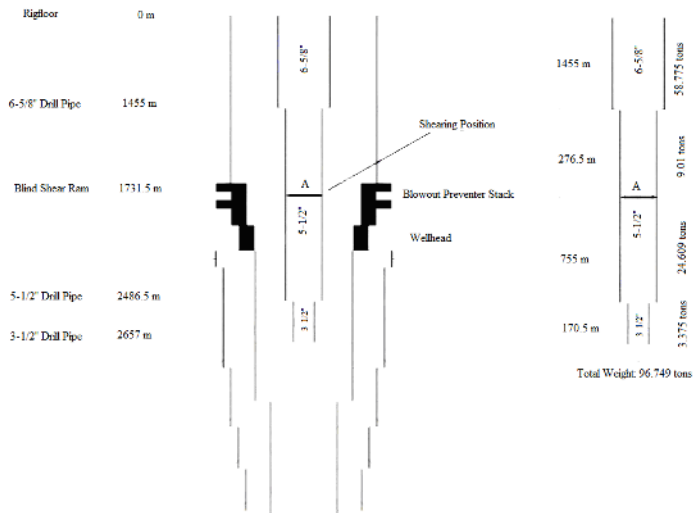

Fig. 9. Examined well configuration

Table 5 Pipe properties used in the well configuration

#	Pipe dimensions						
	O.D.		Wall thickness		Weight length ratio		Material
	(inch)	(mm)	(inch)	(mm)	(ppf)	(kg/m)	
209	6 5/8	168.3	0.362	9.195	27.6	41.073	S-135
135	5 1/2	139.7	0.361	9.169	21.9	32.591	S-135
83	3 1/2	88.9	0.368	9.347	13.3	19.793	S-135

Since there was fluid (mud and/or formation fluid) inside the well, drill string lost some of its weight. Lost weight could be calculated by determining the buoyancy factor. Fluid density was assumed to be 14 ppf (1677.2 kg/cm<sup>3</sup>) and drill pipe density was taken as the average drill pipe density 8030 kg/cm<sup>3</sup>.

$$\text{Buoyancy Factor: } 1 - \frac{\rho_{fluid}}{\rho_{pipe}} = 0.79 \quad (2)$$

The total weight of the drill string in the well with buoyancy factor is represented graphically in Fig 10 (a). The calculated vertical load on shearing position (A) depending on weight gauge (once formation fluid pressure increases through the wellbore, measured weight will decrease) is shown in Fig 10 (b).

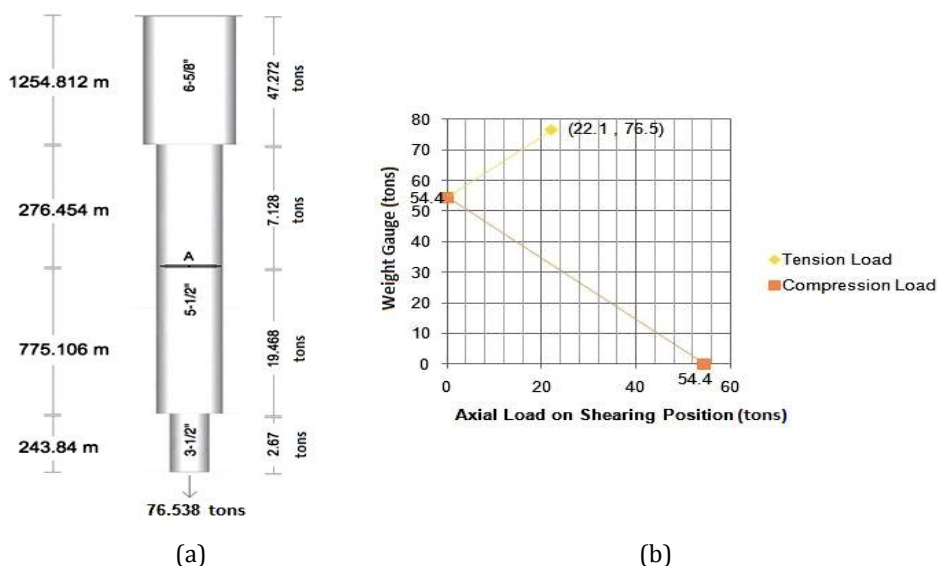

Fig. 10. (a) Calculated weight of the drill string in the well, (b) evaluated axial load on shearing position

As can be seen in Fig 10 (b), the load on shearing position is 22.1tons (tension) when weight gauge shows 76.5 tons, which means all the weight of the drill string is carried by the hoisting equipment. Then measured weight decreases gradually to the 0 ton depending on the formation fluid pressure and flow rate. At this point, load on the shearing position is compression which ends up with maximum 54.4 tons.

Four different vertical loads (5.7 tons and 22.1 tons tension load, 9 tons and 47.7 tons compression load) are applied to the shearing position to determine their effect on the shearing operation. The axial stresses are calculated by using the area of the drill pipe on shearing position and the result is presented in Table 6.

Table 6 Calculated axial stresses on shearing position

#	Weight Gauge (ton)	Vertical Load on Shearing Position		Pipe Area (cm <sup>2</sup> )	Axial Stress on Shearing Position (MPa)
		(ton)	(kN)		
135	19.13	-47.74	-468.33	37.601	-124.55
	38.27	-9.01	-88.39	37.601	-23.51
	53.58	5.67	55.62	37.601	14.79
	76.54	22.1	216.80	37.601	57.66

Boundary conditions are;

Step 1 to 50

- Top of the drill pipe: X, Y fixed and applied stress in -Z direction
- Bottom of the drill pipe: X, Y, Z fixed
- Symmetry plane (-1,0,0)

Step 51 to 1170

- Top of the drill pipe: X, Y fixed and applied stress in -Z direction
- Bottom of the drill pipe: X,Y fixed and applied stress in Z direction
- Symmetry plane (-1,0,0)

The applied vertical loads and the corresponding simulation results are presented in Table 7 and Fig 11. As can be seen in Table 7 and Fig 11, shear force requirement for shearing operation increases significantly with compression load applied on shearing position and decreases with tension load. Also, Fig 11 shows that there is a non-linear relation between applied vertical load and shear force requirement. The shear forces increase with compression load and decrease with tension load dramatically until some point, but then they do not change considerably.

Table 7 Shear forces for different axial load on shearing position

#	Axial load on shearing position	Pipe area (cm <sup>2</sup> )	Axial stress on shearing position (MPa)	Obtained shear force from FEM simulation (Deform 3D) (kN)
135	0 ton (simple sharing)	37.601	0	1197
	47.74 ton compression	37.601	-124.55	1297
	9.01 ton compression	37.601	-23.50	1259
	5.67 ton tension	37.601	14.79	1163
	22.1 ton tension	37.601	57.66	1140

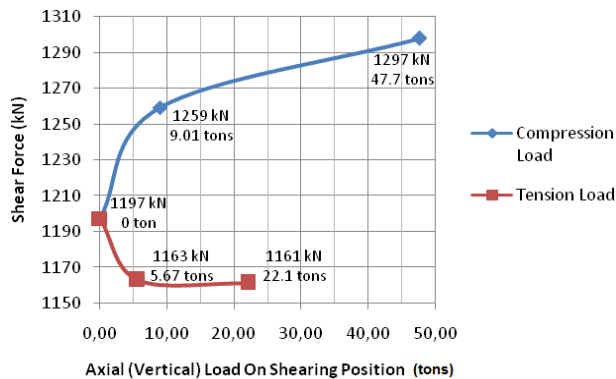

Fig. 11. Shear forces for different vertical loads

In conclusion, the effect of drill string weight on shearing operation can be very important depending on the drill pipe properties used for drilling operation and formation pressure. Therefore, its contribution to the required shear force should be considered as supplementary forces for the shearing operation.

## 5. Conclusions

The drill pipe manufacturers are not willing to give the original flow stress curves of drill pipe materials so the approximated flow stress curves have been used throughout the studies. Although the original flow stress curves shouldn't be very different from the approximated one, due to yield strength, ultimate tensile strength and thru strain will not change, once the original flow stress curves are available, simulations should be repeated to get definite results.

Since the required shear force for the shearing operation increases with compression load on shearing position, blowout preventer stack's accumulator should be designed accordingly.

It is determined that the impact of the vertical compression load on shear force requirement is non-linear. Increase in the required shear force might not be significant after some point of compression load. Thus, the effective range of compression load that has significant impact on the required shear force should be determined. Furthermore, the effective range of compression load might be expressed in terms of drill string weight, so the effect of the possible axial compression load on shear force requirement can be estimated by only using drill string weight for any given well design.

The possible pressure gradient on the blind shear ram can be evaluated for a given formation fluid pressure and well design. Therefore, the effect of pressure gradient on the shear force requirement should be studied depending on given blind shear ram geometries. To decrease shear force requirement for shearing operation, new shear ram geometries should be studied and all tool parameters and edge angles should be optimized.

## References

- [1] Lyons W.C. *Standard handbook of petroleum and natural gas engineering Vol.:1*, Houston, Texas, U.S.; 1996
- [2] Abernethy, R. *Shear ram blowout preventer forces required*. Case Study, Barringer & Associates Inc Florida, U.S.; 2010.
- [3] Vujasinovic, A.N., Shaffer N.L. *How blowout preventers work, journal of petroleum technology, Vol.: 38*, Texas, U.S.; 1986
- [4] Childs, G., Sattler, J., and Williamson, R., 2004. Evaluation of Shear Ram capabilities for the U.S. Minerals and Management Service, Requisition No: 3-4025-1001, West Engineering Service Inc., pp. 4-7, Texas, U.S.
- [5] Holand, P., *Reliability of subsea BOP systems for deepwater application, Phase II DW, SINTEF Industrial Management, Report No STF38 A99426*, Trondheim, Norway; 1999.
- [6] Childs, G., Sattler, J., and Williamson, R. *Review of shear ram capabilities for the U.S. minerals and management service, requisition No: 2*, West Engineering Service Inc, Texas, U.S.; 2002
- [7] Lien R. *Hydraulic analyses of BOP control system, BP deepwater horizon accident investigation Report Appendix Z*, Ultra Deep LLC, Kongsberg, Norway; 2010
- [8] Tekin A., Choi C., Altan T., *Blind shear ram blowout preventers: estimation of shear force and optimization of ram geometry*, MSc Dissertation, The Ohio State University, Columbus, OH, U.S.; 2010
- [9] Williams, R. *BOP manufacturers shear force information, bureau of ocean energy management Regulation and Enforcement, Project Number: 463, Report AB*, Texas, U.S., 2004
- [10] Groover, M.P. *Fundamentals of modern manufacturing; materials, Processes, and Systems*, Third Edition, John Wiley & Sons Inc, New York, U.S.; 2007