

01 Mar 2004

Estimative Current Mode Control Technique for DC-DC Converters Operating in Discontinuous Conduction Mode

Mehdi Ferdowsi

Missouri University of Science and Technology, ferdowsi@mst.edu

Ali Emadi

Follow this and additional works at: https://scholarsmine.mst.edu/ele_comeng_facwork



Part of the [Electrical and Computer Engineering Commons](#)

Recommended Citation

M. Ferdowsi and A. Emadi, "Estimative Current Mode Control Technique for DC-DC Converters Operating in Discontinuous Conduction Mode," *IEEE Power Electronics Letters*, vol. 2, no. 1, pp. 20-23, Institute of Electrical and Electronics Engineers (IEEE), Mar 2004.

The definitive version is available at <https://doi.org/10.1109/LPEL.2004.830245>

This Article - Journal is brought to you for free and open access by Scholars' Mine. It has been accepted for inclusion in Electrical and Computer Engineering Faculty Research & Creative Works by an authorized administrator of Scholars' Mine. This work is protected by U. S. Copyright Law. Unauthorized use including reproduction for redistribution requires the permission of the copyright holder. For more information, please contact scholarsmine@mst.edu.

Estimative Current Mode Control Technique for DC–DC Converters Operating in Discontinuous Conduction Mode

M. Ferdowsi, *Student Member, IEEE*, and A. Emadi, *Senior Member, IEEE*

Abstract—A new control technique for dc–dc converters is introduced and applied to a boost converter operating in discontinuous conduction mode (DCM). In contrast to conventional control methods, the principal idea of the proposed control scheme is to obtain samples of the required signals and estimate the required switch-on time. The proposed technique is applicable to any converter operating in DCM, including power factor correctors (PFC), however, this letter mainly focuses on boost topology. In this letter, the main mathematical concept of a new control algorithm is introduced, as well as the robustness investigation of the proposed method with simulation and experimental results.

Index Terms—Boost converter, dc–dc power converters, discontinuous conduction mode, power factor correction, switched-mode power supplies.

I. INTRODUCTION

SWITCHED-MODE power converters have been employed to correct poor power factor and reduce high harmonic current contents [1], [2]. Boost topology operating in either continuous, or discontinuous conduction mode (CCM or DCM), is one of the most popular topologies for active power-factor correction [3], [4]. In low-power applications, DCM control is a better choice since it reduces the circuit complexity. The boost converter for improving power quality is used as a preregulator and is mostly controlled using a voltage-follower approach while operating in DCM. The ontime duty ratio of the switch is controlled by the output voltage error signal. Because of the automatic current-shaping characteristic of the boost topology, this control method improves the power quality. However, the dynamic response of the converter is very slow.

This letter proposes a new current mode control algorithm for converters operating in DCM. This method is applicable in power factor correctors (PFC), where more precision in power factor correction and faster dynamic response are required, compared to automatic current shapers. The basic idea of this control scheme is to estimate the required value of the duty ratio based on the measured samples of the voltage signals in order to make the average value of the inductor current track the input control signal. This control scheme operates in a fixed frequency.

Manuscript received October 16, 2003; revised April 20, 2004. Recommended by Associate Editor J. Cobos.

The authors are with the Power Electronics and Motor Drives Laboratory, Electric Power and Power Electronics Center, Illinois Institute of Technology, Chicago, IL 60616-3793 USA (e-mail: ferdmeh@iit.edu; emadi@iit.edu).

Digital Object Identifier 10.1109/LPEL.2004.830245

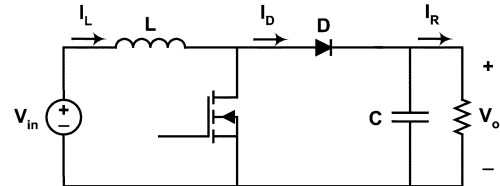

Fig. 1. Boost converter.

The proposed control technique is robust against variations of the circuit parameters and enjoys a very fast dynamic response. Furthermore, it can easily be programmed in a digital signal processor with other required functions, such as a voltage compensator or PFC controller.

II. ESTIMATIVE CURRENT MODE CONTROL

Fig. 1 depicts the circuit diagram of a step-up boost converter. The typical waveforms of the current passing through the inductor and the diode during a single switching period while operating in DCM are shown in Fig. 2.

Assuming that the frequency of the ac ripple of input voltage V_{in} is much less than the switching frequency and the output voltage is fairly constant, we can write

$$I_{max} = d_1 T m_1 \quad (1)$$

$$d_2 T = I_{max} / m_2 \quad (2)$$

where $m_1 = (V_{in})/L$, $m_2 = (V_o - V_{in})/L$, and T is the switching period. Current passing through the diode, $i_D(t)$, is being filtered and delivered to the load, thus, the average value of the diode current is indeed load current i_R . By combining (1) and (2), using the definition of m_1 and m_2 , the average value of the diode current in one switching interval can be obtained

$$i_R = i_{D(av)} = \frac{T}{2L} \left(\frac{V_{in}^2}{V_o - V_{in}} \right) d_1^2. \quad (3)$$

The solution for d_1 yields

$$d_1 = \sqrt{\frac{2L}{T}} * \frac{1}{V_{in}} * \sqrt{i_{D(av)}(V_o - V_{in})}. \quad (4)$$

This formula is used as a new method to estimate the required switch-on time duration in a way that the average current of the diode follows the desired current command signal (CCS). The CCS could be

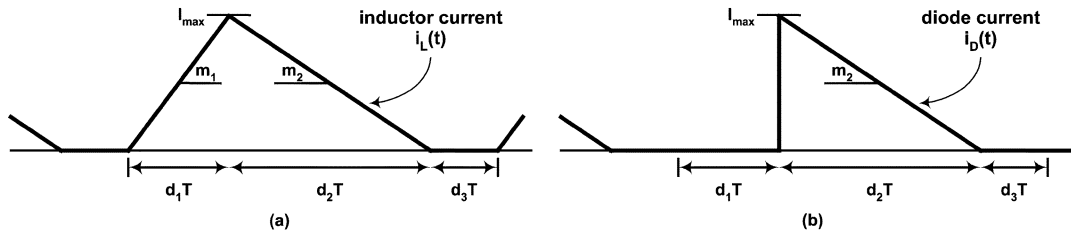

Fig. 2. Typical current waveforms of (a) inductor and (b) diode operating in DCM.

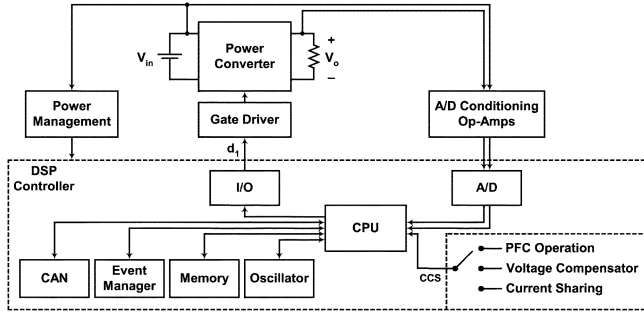

Fig. 3. Block diagram of the digital current controller.

- 1) output of the voltage compensator circuit, which conducts the output voltage regulation;
- 2) output of the load-sharing controller, which tries to balance the output current of the converters operating in parallel;
- 3) output of the power factor corrector, which tempts to generate sinusoidal input current.

Thus, at the beginning of each switching interval, input and output voltages as well as the current command signal, if it is not already a digital signal, are being sampled. Then knowing the dynamic of the converter (4), the controller computes the desired value of duty cycle d_1 . Applying this value of the duty cycle to the converter makes the average value of the diode current follow the current command signal. The required mathematical computations can easily be programmed in a digital signal processor (DSP). Fig. 3 shows the block diagram of the controller. Based on the specific application, the current command signal can be obtained using the same DSP, another DSP with a higher level, or an analog circuit.

Fig. 4(a) and (b) show the simulation results of the transient response of the converter to the step-down and up-change of the current command signal. The inductor current is sketched in the figures, however the estimation is made based on the average value of the diode current. As can be observed, the inductor current pattern immediately follows the current command changes in a way that provides the required average current in the diode. This delay-free tracking characteristic provides a fast dynamic response.

III. ERROR IN INDUCTANCE ESTIMATION

As we can observe from (4), the controller employs the numeric value of inductor L to calculate the desired value of duty cycle d_1 . The rest of the variables in (4) are being sampled

in each period. Therefore, the accuracy of the calculations depends on the accuracy of the inductor value. As a result, an error in the estimation of L degrades the tracking accuracy of the steady-state response of the converter. If ΔL represents the error in the numeric value of L , applying $L + \Delta L$ in (4) yields

$$d_1 = \sqrt{\frac{2(L + \Delta L)}{T}} * \frac{1}{V_{in}} * \sqrt{i_{D(av)}(V_o - V_{in})}. \quad (5)$$

Rearranging the terms in (5) leads us to

$$d_1 = \sqrt{\frac{2L}{T}} * \frac{1}{V_{in}} * \sqrt{\left(1 + \frac{\Delta L}{L}\right) i_{D(av)}(V_o - V_{in})}. \quad (6)$$

The third term in (6) can be interpreted as an error in the current command signal. So the generated current will be slightly different from the real value of the current command signal. Since the variation of L is slow and basically temperature or age dependent, even a very low-bandwidth voltage-control loop can easily damp this error to zero. Fig. 5 depicts the simulation results of the response of the boost converter, with its voltage loop open, if a 25% step error occurs in the assumed value of the inductor (L). As we can observe from (6) and the simulation results, even applying a 25% instant error has only a slight effect on the operating point of the converter. Therefore, the control algorithm is not sensitive to the numeric value of the inductor, which is the only presumed parameter in (4).

IV. POWER FACTOR CORRECTION

Using this technique we can achieve any current tracking property that we are interested in, for instance, PFC. In a DCM PFC application we try to shape the average value of the input current in a way that it follows the sinusoidal input voltage pattern. Considering the boost converter and its inductor current waveform (input current) in Fig. 2, we can write

$$i_{L(av)} = \frac{T}{2L} \left(\frac{V_o V_{in}}{V_o - V_{in}} \right) d_1^2 \quad (7)$$

which is slightly different from the average value of the diode current obtained in (3). The solution for d_1 yields

$$d_1 = \sqrt{\frac{2L}{T}} * \sqrt{i_{L(av)} \frac{V_o - V_{in}}{V_o V_{in}}}. \quad (8)$$

In the PFC application, $i_{L(av)}$ needs to be proportional to the rectified input voltage waveform. Thus, we can write

$$i_{L(av)} = A * |V_{in}| \quad (9)$$

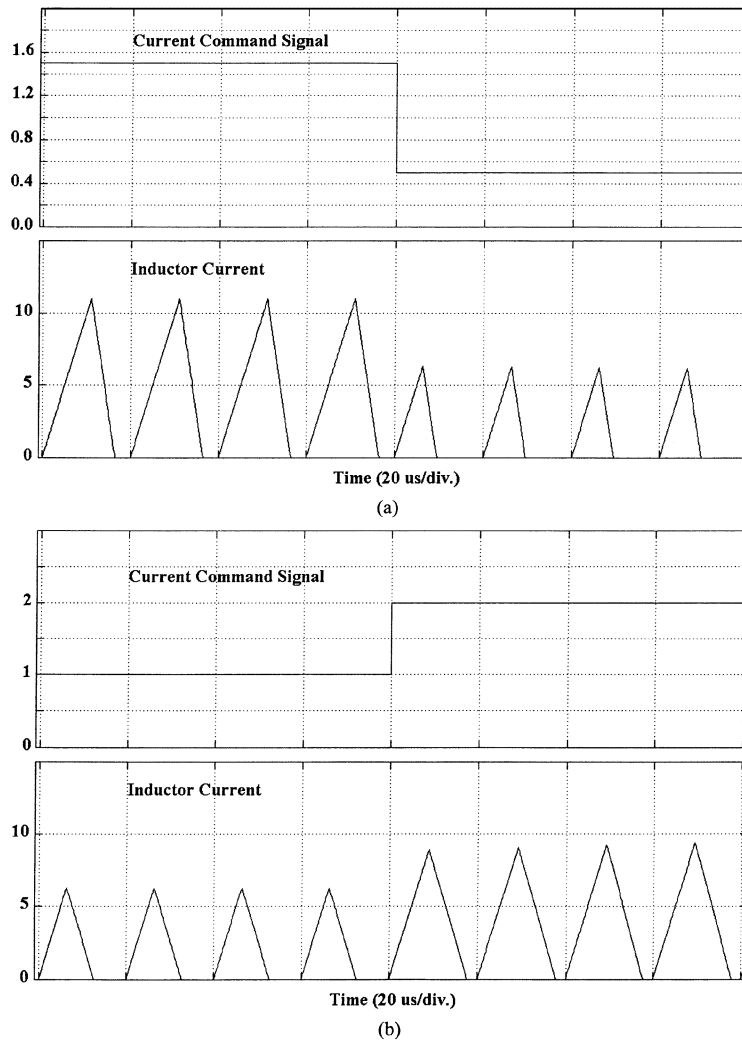

Fig. 4. Simulation results of the converter transient response to a step change in the current command signal: (a) step down and (b) step up.

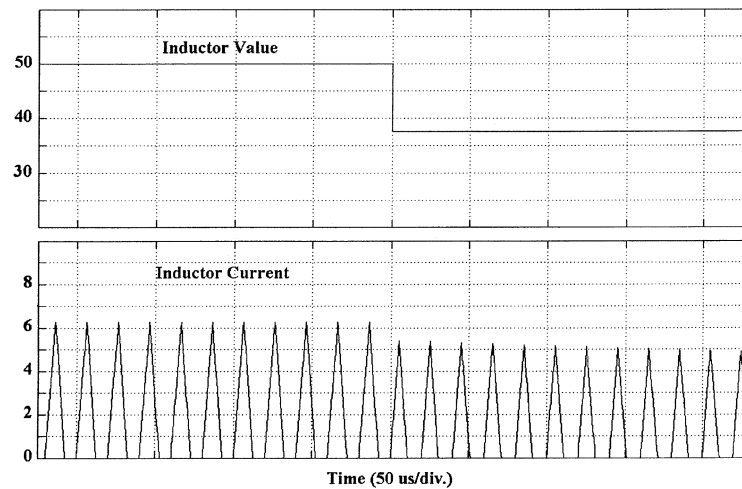

Fig. 5. Simulation results of the open loop response to a 25% step change of the inductor value.

where gain A is determined by the voltage compensator based on the required output power. In the above equation the full-rectified sinusoidal input voltage is used as the reference of the inductor current in such a way that the input current tracks the input

voltage. Fig. 6 depicts the block diagram of the PFC converter. Fig. 7 shows the simulation results of the input current of the PFC converter. As can be observed, the average value of the input current follows the sinusoidal wave shape of the input voltage.

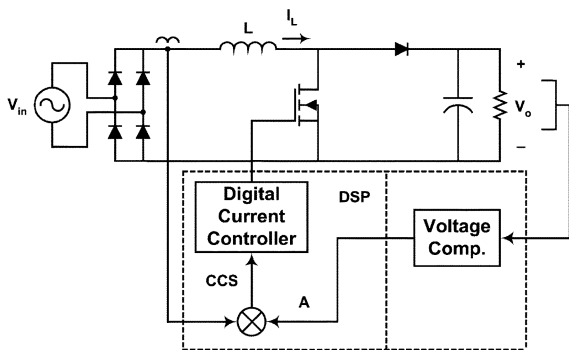

Fig. 6. Block diagram of the PFC converter.

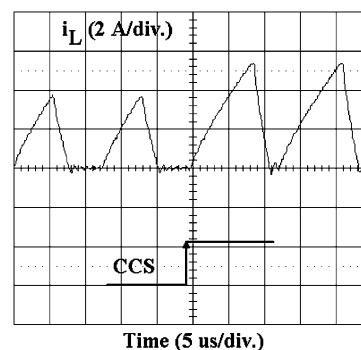

Fig. 9. Inductor current transient response to a step up change in CCS.

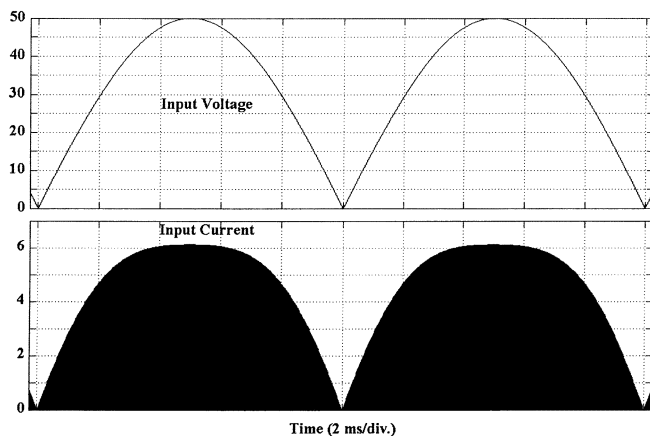

Fig. 7. Input voltage and current in PFC application.

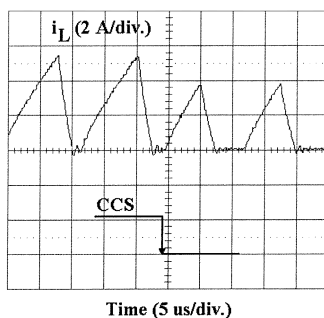

Fig. 8. Inductor current transient response to a step down change in CCS.

V. EXPERIMENTAL RESULTS

A TMS320LF2407A digital signal processor has been employed for the experimental implementation of an 80-W boost converter with a switching frequency of 80 KHz using the new estimative current mode control. The duty cycle was presented by an 8-bit binary digit and a look-up table was used to implement the square-root function. In order to cancel limit cycling, the resolution of the ADCs was chosen to be 7-bit, one bit less than the resolution of the duty cycle. The ADC and computational time delay were measured to be less than one microsecond, or less than 7% of the switching period. Figs. 8 and 9 show the experimental results of the boost converter being controlled with the estimative digital current control. These figures

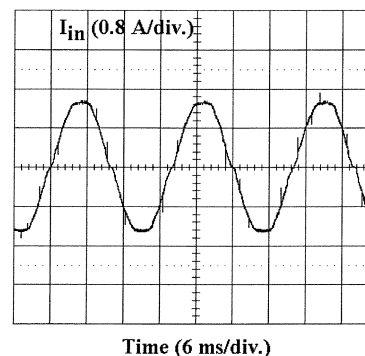

Fig. 10. Input current of the PFC converter after being filtered by the EMI filter.

depict the transient response of the inductor current after a step change was applied to the current command signal. Fig. 10 depicts the sinusoidal input current of the PFC converter being filtered by the EMI filter. The experimental results highly agree with the simulation results and the system has a very fast dynamic response.

VI. CONCLUSION

Both simulation and experimental results showed that the estimative current mode control technique that has been introduced in this report enjoys the following benefits:

- 1) it has a very fast transient response;
- 2) it is stable for any value of the duty cycle;
- 3) it is easy to be implemented by a digital processor;
- 4) it is not sensitive to the circuit parameter variations.

REFERENCES

- [1] S. B. Dewan, "Optimum input and output filters for a single-phase rectifier power supply," *IEEE Trans. Ind. Applicat.*, vol. 17, pp. 282-288, May/June 1981.
- [2] M. Kocher and R. Steigerwald, "An ac to dc converter with high quality input waveform," in *Proc. IEEE Power Electronics Specialists Conf.*, June 1982, pp. 63-75.
- [3] K. H. Liu and Y. L. Lin, "Current waveform distortion in power factor correction circuits employing discontinuous-mode boost converters," in *Proc. IEEE 20th Annu. Power Electronics Specialists Conf.*, vol. 2, Milwaukee, IL, June 1989, pp. 825-829.
- [4] J. Lazar and S. Cuk, "Open loop control of a unity power factor, discontinuous conduction mode boost rectifier," in *Proc. 17th Int. Telecommunications Energy Conf.*, Oct.-Nov. 1995, pp. 671-677.