

Evaluation Of 1d And 2d Texturing Of Monocrystalline Solar Cell

F. Jahanshah, K. Sopian, I. Ahmad, M. Y. Othman, Azami Zaharim, S. H. Zaidi

Abstract- The performance of solar cell with periodic surface texture pattern was reported. One and two dimensions texturing with the nitride antireflection coating were compared. An *I-V* tester calibrated by Sandia National Laboratories was used. A 2 cm² bare monocrystalline silicon solar cell was chosen for comparison. 2D surface texturing showed the best output with maximum short current 0.050 mA. A meteoritic 3D microscope was used to check the textured surface as a non distractive test (NDT).

Keywords- solar cell, texturing, one and two dimensions grating, efficiency, current variation

I. INTRODUCTION

It was shown texturing can be considered as a good candidate to solve the cost price and efficiency problem of thin solar cell [1]. By texturing the light are traveled more inside the cell and the absorption of it was increased as the length of traveling increased. The shape and the size of the patterns could affects on the efficiency.

The interaction of KOH with silicon was making very fine pyramids as a texturing in the solar cell. In micro-electronics area the photolithography method, made some investigation on texturing and good efficiency such as inverted pyramids that used in PERL cell or PESC cell structure. In both of these two kinds, diffusion and surface passivation, by oxide or nitride, are effected early in the cell fabrication sequence, after surface etching and texturing [2]. One and two diminutions grating (1-D & 2-D) are other candidates of texturing that recently are investigated (Fig.1) [3, 4 and 5].

Manuscript received May 23, 2007; Revised received November 2 2007.

F. Jahanshah, K. Sopian, I. Ahmad, M. Y. Othman, Azami Zaharim, Solar Energy Research Institute, Universiti Kebangsaan Malaysia, 43600 Bangi Selangor, MALAYSIA

S. H. ZAIDI, Gratings, Incorporated, 2700 B Broadbent Pkwy., NE, Albuquerque, NM 87107, UNITED STATES OF AMERICA
jahan@eng.ukm.my

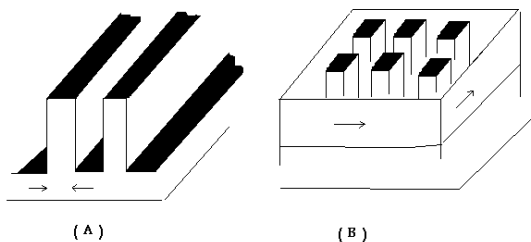

Fig.1: surface of solar cell with grating textured. (A) One dimension texturing and (B) two dimension texturing

This paper presents the performance of the solar cell with 1-D and 2-D texturing with antireflection coating. Both of texturing were fabricated in a same unit cell in order to eliminate the effects of materials deflect and electrical and physical measurement conditions [5]. For comparison the periods were chosen the same i.e. about 3.5 μ m.

II. I-V CURVE TESTER

The *I-V* curve testers was designed and fabricated by Grating, Inc company and was calibrated by Sandia National Laboratories. A halogen lamp in 1 meter height was used as the optical source. Two probes and a copper base were used to collecting the current from the surface of solar cell and induce the reverse voltage. With an electronic circuit the applies voltage change in specific equal intervals. With an interpolator as software we find out the real *I-V* curve and monitoring by a computer. Fig.2 shows internal circuit of the tester. The output curve is shown in Fig. 3. Usually for comparison we use SigmaPlot to change output data to graphical data.

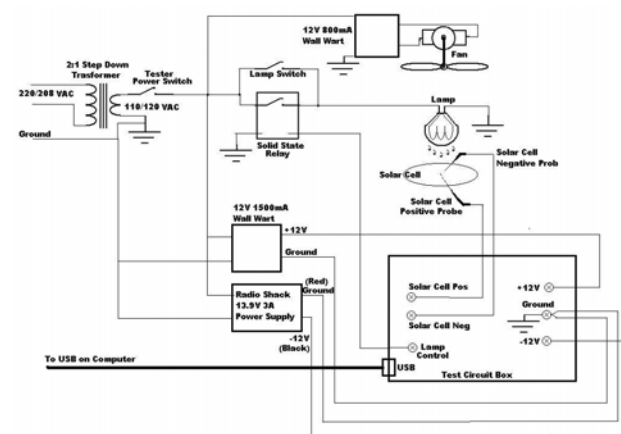

Fig. 2: a schematic circuit of *I-V* tester that was used in measurement.

III. OPTICAL SURFACE MEASUREMENTS

Different surface structures were measured by IfiniteFocus as an optical 3D measurement microscope which work in micro- and nano range. Its operating principle combines the

small depth of focus of an optical system with vertical scanning to provide topographical and color information from the variation of focus. The method of operation by 3D microscope is based on focusing in and out of real focus. Interpreter software makes the 3D image and by using new method it's possible to increase the digital magnification to 10X. These measurements not affected the solar cell during the test as non destructive test (NDT). For future work we may have to use SEM microscope for more details picture. 1-D and 2-D texturing zone picture is shown in Fig.3 and 4 respectively.



Figure 3: solar cell with 1D texturing without nitride antireflection.

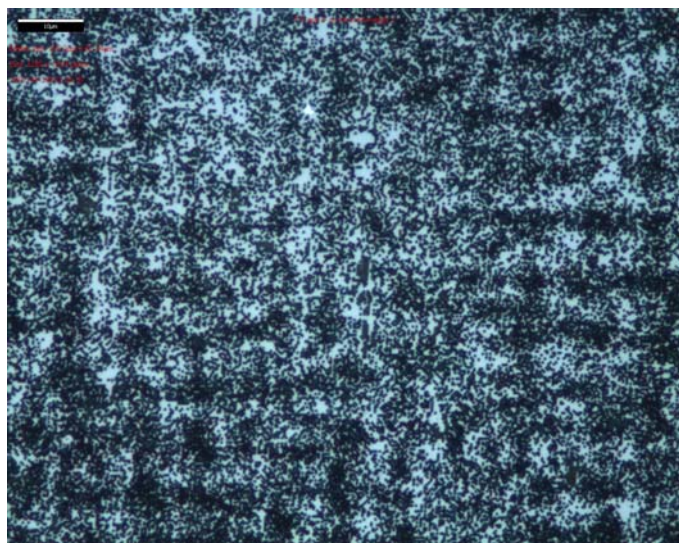

Figure 4: solar cell with 2D texturing without nitride antireflection.

IV. SOLAR CELL CHARACTERISTICS

Three solar cells in our propose measurements. One with three different textures in some identifies zones

and two others for comparison the effect of coating on planer solar cell were considered. A 2 cm² mask to cover it in order to protect the other part in light exposes. The first zone is planer solar cell without any texture (bare). Table 1 shows the open circuit voltage and the short circuit current of the zones. The measurements were conducted at 1 sun illumination.

Fig.5 shows the I-V curve of two planer cells with and with out the anti-reflection coating. As expected the performance of cell with nitride antireflection is much better than another. The open circuit and short current for planer bare solar cell 7% and 34% are bossed respectively by coating. The third cell was consisted of three zone samples. All are coated with antireflected nitride material. Fig.6 shows I-V plot of the 1-D and 2-D textured solar cell in comparison with the planer surface. As we found the performance of cell with 2-D texturing are much better than 1D and planer silicon solar cell due to light diffraction All of these measurements were done in 1 sun illumination.

Table 1: open circuit voltage and short circuit current for different solar cell texturing samples in 1 sun illumination

sample	Size (mm)	Voc (Volts)	Isc (mA)
711-planer-no nitride	20×20	0.4810	0.0383
711-planer-with nitride	20×20	0.522	0.0581
711-grat 2(zone 3) 1D	20×20	0.4812	0.0451
711-grat 2(zone 4) 2D	20×20	0.4862	0.0507
711-grat 2(zone 5) bare	20×20	0.422	0.0422

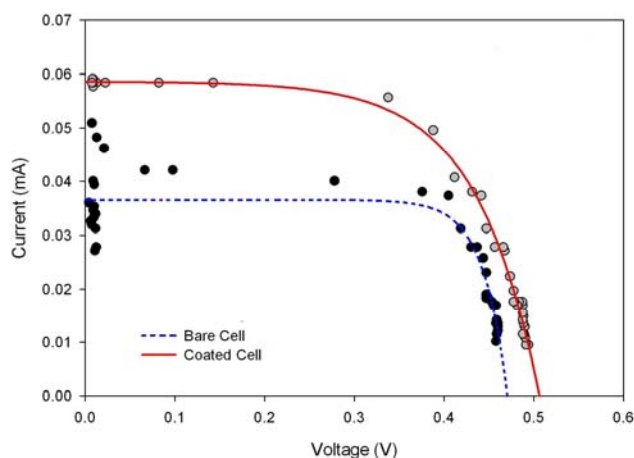

Fig.5: I - V plot of planer solar cell with and without antireflection nitride layer in 1 sun measurement.

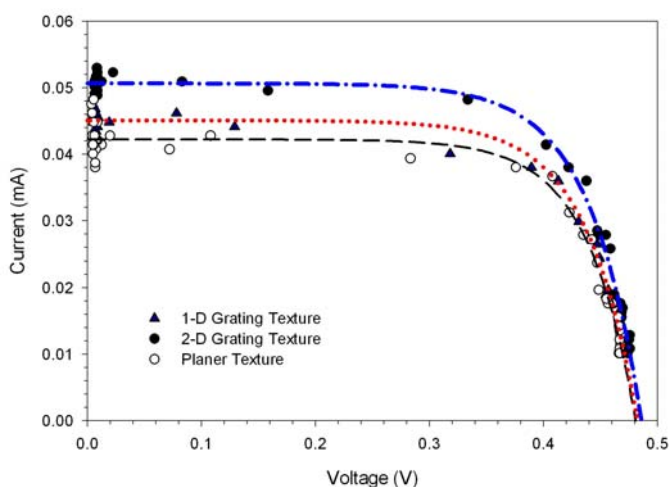

Fig.6: I - V plot of 2D textured solar cell with and without antireflection nitride layer in 2cm^2 in 1 sun measurement.

V. CONCLUSIONS

The performance of solar cells changed as the texturing changed. It is found that 1D and 2D texturing has good output and performance in compare to planer samples. In our measurement we have not good details of surface texturing because of poor magnification of optical microscope. It is suggested to using SEM image microscope to find more dilates.

REFERENCES

- [1] S. H. Zaidi, "Diffraction Grating Structures In Solar Cells," *IEEE*, 2000.
- [2] M. A. Green, "Progress and outlook for high-efficiency crystalline silicon solar cells," *Solar Energy Materials & Solar Cells* vol. 65, pp. 9-16, 2001.
- [3] S. Michael, "Silvaco Atlas as a solar cell modeling tool," *IEEE*, pp. 719, 2005.
- [4] M. G. Moharam, "Rigorous Coupled-wave Analysis of Planar-Grating Diffraction," *Optical Society of America*, vol. 71, pp. 811, 1981.
- [5] S. H. Zaidi, "Deeply Etched Grating Structures for Enhanced Absorption in Thin C-Si Solar Cells," *IEEE*, pp. 1290, 2002.