

Evaluation of Commercial Off-the-Shelf Sorbents and Catalysts for Control of Ammonia and Carbon Monoxide

Bernadette Luna, Ph.D.* George Somi† J. Parker Winchester‡, Jeffrey Grose§, Lila Mulloth**
NASA Ames Research Center, Bioengineering Branch, Moffett Field, CA 94035-1000

and

Jay L. Perry††
NASA Marshall Space Flight Center, ECLS System Development Branch, MSFC, Alabama 35812

Designers of future space vehicles envision simplifying the Atmosphere Revitalization (AR) system by combining the functions of trace contaminant (TC) control and carbon dioxide removal into one swing-bed system. Flow rates and bed sizes of the TC and CO₂ systems have historically been very different. There is uncertainty about the ability of trace contaminant sorbents to adsorb adequately in high-flow or short bed length configurations, and to desorb adequately during short vacuum exposures. There is also concern about ambient ammonia levels in the absence of a condensing heat exchanger. In addition, new materials and formulations have become commercially available, formulations never evaluated by NASA for purposes of trace contaminant control. The optimal air revitalization system for future missions may incorporate a swing-bed system for carbon dioxide (CO₂) and partial trace contaminant control, with a reduced-size, low-power, targeted trace contaminant system supplying the remaining contaminant removal capability. This paper describes the results of a comparative experimental investigation into materials for trace contaminant control that might be part of such a system. Ammonia sorbents and low temperature carbon monoxide (CO) oxidation catalysts are the foci. The data will be useful to designers of AR systems for future flexible path missions. This is a continuation of work presented in a prior year, with extended test results.

I. Introduction

Future long duration space exploration missions require advancements in Atmosphere Revitalization (AR) technologies in order to reduce power consumption and mass, and to increase reliability. Current AR systems include separate processors and air loops for removal of metabolic carbon dioxide and lower-level trace contaminants (TCs). Some Environmental Control and Life Support (ECLS) systems engineers envision simplifying the AR subsystem by combining the functions of TC control and carbon dioxide (CO₂) removal into a single regenerable bed system. There are four general concerns associated with this vision of an integrated AR system: a) performing a TC control function under the flow rates typical in the CO₂ removal swing-bed, b) the stability of carbon impregnants under extended vacuum exposure c) potential for higher ammonia levels coupled with a need

* Research Physical Scientist, Bioengineering Branch, Biosciences Division, Building N239 Room 107, Moffett Field, CA 94035-0001, Senior Member.

† Exploration Systems Mission Directorate Intern, Arizona Space Grant Consortium, Embry-Riddle Aeronautical University, 3700 Willow Creek Rd. #8206, Prescott, AZ 86301, Student Member.

‡ Education Associates, University Space Research Association, Mail Stop 226-8, NASA ARC, Moffett Field, CA 94035-1000, non-member.

§ Test Engineer, Bay Area Environmental Research Institute, 560 3rd St West, Sonoma, CA 95476, non-member.

** Senior Engineer, SAIC Technology Services Company, 2450 NASA Parkway, Houston, TX 77058, Member.

†† Senior Engineer, Environmental Control Systems, Engineering Directorate, Space Systems Department, ECLS System Development Branch, NASA MSFC/ES62, MSFC, Alabama, 35812, non-member.

for a new flight-qualified ammonia sorbent, and d) the desire to reduce power in the oxidizer through the use of new lower temperature catalysts. The latter two concerns are addressed in this paper^{††}.

A. Design Challenges and Considerations

Trace contaminant control equipment designers must balance a variety of spacecraft design and ECLS equipment performance goals. Among these challenges TC control equipment designers must consider how target compounds drive TC control equipment process conditions, vacuum stability of adsorbent and catalyst media, the incidental removal of TCs by other AR process equipment, and spacecraft resource conservation.

1. Factors Influencing TC Control Process Conditions

The first concern stems from differences in target contaminant control levels and global reaction rates in the two systems, which define optimal bed configurations and flow rates. On board the International Space Station (ISS) U.S. On-orbit Segment (USOS), TCs are removed using two packed beds—a granular activated carbon (GAC) for high molecular weight contaminants and ammonia (NH₃) followed by a heated catalytic oxidizer for low molecular weight hydrocarbons such as carbon monoxide (CO) and formaldehyde (CH₂O). The carbon bed is expendable and is periodically refurbished. In a parallel air purification process, CO₂ removal is accomplished via a swing-bed system that periodically vents CO₂ to space.

Flow rates and bed sizes of the current TC and CO₂ removal systems are very different. These differences are typically driven by cabin air quality requirements such as maximum allowable concentration and contaminant generation rates. For instance, ammonia (NH₃) removal drives the GAC bed size and flow rate while methane (CH₄) and carbon monoxide (CO) drive the catalytic oxidizer size and flow rate for the ISS TC control system (TCCS). The ISS TCCS GAC bed has a contact time of ~12 s and the thermal catalytic oxidation bed has a contact time of 0.67 s reflecting the varying process flow rate and bed volumes. The TCCS GAC bed contains 0.033 m³ activated carbon (~23 kg), with process air flow of ~15 m³/h. The thermal catalytic oxidation bed contains ~0.5 kg palladium (Pd) catalyst on alumina (Al₂O₃) pellets, with a flow rate of 4.6 m³/h.^{1, 2} By comparison, the ISS carbon dioxide removal assembly (CDRA) consists of 4 packed beds—2 containing silica gel and zeolite 13X desiccant media and 2 containing zeolite 5A CO₂ sorbent media. The CO₂ sorbent beds contain 16,000 cm³ of material. Process air flow through the CO₂ sorbent beds has ranged from 15.2 m³/h to 35.6 m³/h, resulting in a 1.6 s to 4 s contact time.³ In contrast, an amine-based CO₂ removal process under development employs ~3.5 kg of media in 6,200-cm³ beds yielding a 0.25 s contact time. The amine system is designed for short duration missions and vents water and CO₂; it is therefore smaller than the ISS 4BMS system, which recovers water and can provide CO₂ for reduction processing. Process air flow through a 4-crew amine system is 88.4 m³/h.⁴ For simplicity, all contact times mentioned are superficial, that is, calculated using an empty tube or void volume equal to 1; actual contact times would be lower by 60-65%.

In all, there is a range of flow requirements needed to meet the cabin air quality specifications. Some overlapping middle ground does exist such that a regenerable AR system could incorporate both TC and CO₂ sorbent materials in a new configuration, potentially incorporating high flow rates, shorter bed lengths, shorter residence times, and short desorption cycles. This new vision necessitates a re-evaluation of the current TC sorbent as well as comparable evaluation of newer sorbent materials, now commercially available, which have never been evaluated for this purpose. The current effort contributes to this re-evaluation.

2. Bed Packing Vacuum Stability

There is also concern about sorbent vacuum stability. The Crew Exploration Vehicle was envisioned to have no airlock; some flexible path vehicles could be similar. Therefore an emergency extravehicular activity (EVA) would require a depressurization of the cabin. It is unknown whether vacuum exposure removes the activating ions on Barnebey-Sutcliffe (B-S) Type 3032 granular activated carbon, or ions on any of the potential replacement materials, thus reducing that material's capacity for NH₃ adsorption. This concern was addressed with work described in Reference 5.

3. Ammonia Removal Mechanisms

Third is a growing concern about NH₃ as a contaminant and its key role in defining TCCS equipment design. Testing conducted for the ISS Program found that the condensing heat exchanger and CDRA provide an assist to the TCCS.⁶ This testing found the condensing heat exchanger can remove approximately 55% of the NH₃ cabin load while the CDRA removes approximately 22%. Although the TCCS was designed to handle 100% of the NH₃ cabin load the testing indicated that it would likely have to remove only about 23%. This finding leads to TCCS GAC bed utilization economy. The broader implication is the design challenge presented by AR subsystem design attempts to

^{††} The mention or use of any commercial product is not an endorsement of the product by NASA.

merge the TC, CO₂, and humidity control functions with the goal of eliminating the condensing heat exchanger commonly used today.

More recently, for health and wellness reasons, NASA toxicology experts have lowered the space maximum allowable concentration (SMAC) for ammonia to 7 ppm.⁷ Ammonia's high vapor pressure and low molecular weight make it difficult to remove. On board ISS, NH₃ is removed with B-S Type 3032 4×6 mesh GAC. Type 3032 activated carbon is treated with phosphoric acid (H₃PO₄) and is no longer commercially available. These factors amplify the concern about NH₃ as a contaminant and emphasize the need to characterize the efficiency and capacity of commercially available NH₃ sorbents.

4. *Opportunities for Spacecraft Resource Conservation*

Beyond these challenges and considerations, there are opportunities for power savings in the TC control process design. The ISS TCCS high temperature catalytic oxidizer (HTCO) provides control not only for CH₄ and CO but also for small molecular weight compounds such as formaldehyde (CH₂O) and light alcohols. However, the HTCO reactor operates at 400°C and, therefore, requires significant power to provide high single pass oxidation efficiency for CH₄. Most other hydrocarbons of interest can be oxidized at lower temperatures. As well, since the ISS TCCS design was established, new lower temperature oxidation catalysts have been developed which may be more poisoning resistant and therefore longer lived than previous products available. These materials offer promise for lowering power for the catalytic oxidation unit operation for future spacecraft TCCS equipment. Advances in catalyst substrates also allow for more efficient heating.⁸

B. The Investigative Focus

The focus of this work is evaluation of commercially available materials for removal of ammonia and catalysts for room temperature oxidation of carbon monoxide. Specific questions to be answered include the following:

- 1) Does the manufacturer's replacement product for B-S Type 3032 carbon offer equivalent NH₃ removal capacity and performance?
- 2) Are there additional materials available for gaseous NH₃ removal and how do their NH₃ capacities compare with the NH₃ capacity of B-S Type 3032?
- 3) How does the presence of water vapor affect NH₃ capacity?
- 4) What materials are commercially available for ambient temperature CO oxidation?
- 5) Can recommendations be made for (or against) using any tested materials, or for larger scale testing or for modified production of any tested materials?

II. Experimental Methods and Results

A. Materials Studied

Fourteen NH₃ sorbents and six CO oxidation catalysts were evaluated. Three of the sorbents were not commercially available; they were custom-made based on data in the literature that suggested a high capacity for ammonia removal. Salient details are summarized for each.

1. *Ammonia Sorbents*

Seven commercially available carbon-based NH₃ sorbent materials, seven zeolites (3 commercially available and 4 custom), and one commercial catalyst were procured for comparative NH₃ removal performance — B-S Type 3032, Calgon Carbon Ammonasorb II, Nucon International Ammosorb I-3, Tigg HP carbon, carbon removed from a 3M 6004 NH₃/methylamine (CH₃NH₂) respirator mask cartridge, Molecular Products Chemsorb 1425, carbon removed from the Dräger AM/MA NH₃/methylamine (CH₃NH₂) X-plore respirator mask cartridge, Tigg KLS zeolite, St. Cloud natural zeolite (clinoptilolite), UOP's HISIV 3000 zeolite and Mine Safety Technologies LTCAT are all purported to have capacity for gaseous ammonia removal. In addition, the literature suggests the Y-zeolite, ion-exchanged with cobalt or copper has improved capacity for gaseous ammonia removal. Fig. 1 shows each sorbent material and Table 1 provides information on bulk density and particle size range for each. Particle size ranges are indicated by the U.S. Series screens that bound > 97% of the material by mass. For example, 8x14 indicates that most particles fall through a No. 8 U.S. Series screen (8 wires per inch with a 2.38 mm opening) and are captured on a No. 12 U.S. Series screen (12 wires per inch with a 1.68 mm opening). When particles were smaller than the highest No. screen available, this is indicated by a negative sign with the screen series number (e.g., -20 indicates that all particles fell through a No. 20 screen).

Each of the carbons is impregnated with an activating ion to facilitate reaction with NH₃ gas. Untreated carbons typically do not remove NH₃ because of its low molecular weight and high vapor pressure. B-S Type 3032 carbon is treated with H₃PO₄ to a total acid content of approximately 10% by weight. B-S Type 3032 carbon has flown on ISS since the U.S. Laboratory activation in February 2001. Particles are irregularly shaped granules.

While the ISS program (and this lab) maintains some B-S Type 3032 in storage inventory, it is no longer commercially produced. B-S's (now Calgon Carbon's) replacement product for Type 3032 is Ammonasorb II, a coconut shell carbon also treated with H₃PO₄. Ammonasorb II has a quoted NH₃ capacity of 7 to 16% by weight, comparable to Type 3032. Particles are irregularly shaped granules.

Nucon International offers a competitive product, Ammosorb I-3, which is a coal-based carbon treated with nitrate activating ion. It has a manufacturer's quoted NH₃ capacity of 5% by weight. Ammosorb is formed as pellets, not irregularly shaped granules, with average pellet size 3 mm diameter (6×8 mesh).

The Tigg carbon, Tigg HP, is treated with about 10% phosphoric acid and particles are irregularly shaped granules.

A carbon used by 3M in its product number 6004 NH₃/CH₃NH₂ respirator cartridges was also evaluated. The impregnant was determined via ion chromatography to be ZnCl₂. Particles are irregularly shaped granules.

Molecular Products Chemsorb 1425 is another coconut-shell carbon containing about 10% phosphoric acid to target ammonia and amine compounds. As with most of the carbons tested, particles are irregularly shaped granules.

Carbon was removed from the Dräger X-plore AM/MA filter; it was found to contain about 4% chloride ion by weight. Dräger procures this carbon from an outside source. Granules are irregularly shaped.

The catalyst product, LT-CAT from Modern Safety Techniques, reportedly has capacity to remove NH₃⁹⁻¹⁴ so it was evaluated for that capability. It is comprised of a proprietary formula that includes primarily copper chloride (CuCl₂) with some palladium chloride (PdCl₂) on Al₂O₃ support beads. The material also contains some nickel (Ni). As shown in Figure 1 the material is blue to blue-green in color and particles are near-spherical.

Tigg KLS is a natural zeolite, comprised of irregularly shaped beige granules. The St. Cloud natural clinoptilolite zeolite consists of 12×16 mesh, beige granules. It is used in animal feed, as an additive to animal stalls to reduce ammonia emissions and as a soil amendment. UOP HiSIV zeolite particles are 0.16 cm diameter (1/16th inch) beige, cylindrical pellets, about 0.3-0.4 cm long.

Custom Cu- and Co-ion-exchanged X- and Y-type zeolites were prepared by the University of Puerto Rico, Mayaguez campus, according to the methods of Liu and Aika¹⁵, using synthetic Na-X and Na-Y zeolite powders from Sigma-Aldrich. After the ion-exchange process the materials were pelletized using a punch and die, then crushed via mortar and screened to produce 20×40 mesh granules of each variation. Co-Y and Cu-Y zeolites were noted to adsorb 0.15 and 0.16 g/g (8.64 and 9.34 mmol/g) at 323K by Liu and Aika, a 50% increase over Na-Y-zeolite and a factor of 5 higher than the 3% loading found earlier using carbon from the 3M 6004 ammonia/methylamine mask cartridge. Although the work of Joshi et al¹⁶ notes reduced ammonia adsorption on cation-exchanged K-, Rb-, and Cs-X-zeolites, Co-X and Cu-X were prepared along with the Y-zeolites for a more thorough understanding of the interaction NH₃ with these cations. Data for NH₃ loading on Cu-Y, Co-Y, and Cu-X are included here.

Table 1. Properties of NH₃ sorbents evaluated.

MATERIAL	(g/cc)	(US Series)
Barnabe & Sutcliffe 3032	0.73	6x12
Calgon Carbon Ammonasorb II	0.66	6x12
Ammosorb I-3	0.69	6x8
3M 6004 AM/MA mask cartridge carbon	0.68	14x20
Tigg HP	0.76	4x12
Molecular Products Chemsorb 1425	0.75	14x20
Dräger Drägercarb	0.63	14x20
Tigg KLS	0.90	6x8
St. Cloud Zeolite	0.90	12x16
UOP HISIV 3000	0.71	8x14
Modern Safety Technologies LTCAT	0.47	6x8
Co-X zeolite	0.63	20x40
Cu-X zeolite	0.72	20x40
Co-Y zeolite	0.57	20x40
Cu-Y zeolite	0.56	20x40



Figure 1. Materials evaluated to date for NH₃ removal capacity. a) B-S Type 3032 carbon, b) Calgon Carbon Ammonasorb II, the vendor's 'replacement' carbon, c) Nucon International Ammosorb I-3, d) Tigg HP, e) 3M 6004 amine/methylamine mask cartridge, f) Molecular Products Chemsorb 1425, g) Dräger Dragercarb, h) Modern Safety Techniques LTCAT, i) Tigg KLS zeolite, j) St. Cloud natural zeolite, k) UOP HISIV 3000. l) Co-X zeolite m) Cu-X zeolite n) Co-Y zeolite o) Cu-Y zeolite. Scale markers in inches.

2. Ambient Temperature Oxidation Catalysts

Seven ambient temperature oxidation catalysts, six of which are shown in Fig. 2, were compared for CO oxidation. Table 2 summarizes information on bulk density and particle size for each material. The Carulite 300 catalyst from Carus Chemical, also offered from breathing air compressor original equipment manufacturers, is a manganese dioxide (MnO₂)/copper oxide (CuO) based catalyst, on an Al₂O₃ support pellet. It is a hopcalite-family catalyst, brown/black in color.

Ozone Solutions is a provider of 'all things ozone', offering ozone destruct units for removal of ozone from air. The vendor's web site notes that their catalyst is known as a hopcalite-type of catalyst whose primary constituents

are manganese dioxide and copper oxide. Not surprisingly the material appears very similar to Carus Chemical Carulite 300 in color (black/brown) but particles are pellet-shaped.

A Dräger Parat C smoke hood was obtained; the smoke hood holds a cartridge in which catalyst is contained beneath a filter and perforated plate. The cartridge was opened (irreversibly) to remove catalyst for these evaluations. The material is black/brown, and the particles have irregular shape.

Details of the TDA catalyst formulation are unknown, although it is a gold formulation. It consists of irregularly shaped, black/brown particles, with 14x30 mesh particle size distribution. In practice 99.7% conversion was demonstrated by the manufacturer at 100000 hr⁻¹ gas hourly space velocity (GHSV).^{17, 18} GHSV is the volumetric flow rate divided by the catalyst volume. For the TDA catalyst, this is the equivalent of an ‘empty tube’ contact time of 36 milliseconds, 0.036 seconds, much lower than NASA’s ISS HTCO. However, it was noted that production of quantities on the order of 600 grams was difficult. Under room conditions, the material is somewhat sticky like moist soil, and does not pour as easily as the other materials evaluated here.

The third material, from STC Catalysts, is a Pt-SnO₂ formulation shown to oxidize carbon monoxide at 1% by volume with initial 90% efficiency.¹⁹⁻²⁵ The catalyst was originally developed by the NASA’s Langley Research Center to regenerate CO₂ in closed cycle lasers, and then licensed by STC Catalysts for use in laboratory and commercial CO₂ lasers. The formulation was termed ‘platinized tin oxide’ (Pt-SnO_x), comprised of platinum (Pt) dispersed on a reducible metal oxide substrate (SnO₂), where both the Pt and the SnO₂ play key roles in the mechanism of oxidation. The catalyst can be produced on a cordierite substrate brick, but for this study, it was applied to a 10×20 mesh silica gel granular support. It is black in color and particles are irregularly shaped. The catalyst, shown in Fig. 2, reportedly has capacity to oxidize small molecular weight hydrocarbons such as methane (CH₄), propane (C₃H₈), and CH₂O in addition to CO. In the future the investigation may incorporate these contaminants.

The Modern Safety Techniques material (photo in Figure 1) is a CuCl₂ catalyst with small amounts of PdCl₂ and nickel on alumina beads. A second copper salt serves to stabilize the active metal complex. The material exhibits some characteristics of both heterogeneous and homogeneous catalysis. CO bonds to the active metal complex in solution; some amount of water is necessary for reasonable reaction. The particles are round-shaped and light blue or blue-green in color. The mechanism for CO oxidation is said to proceed as follows:

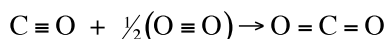
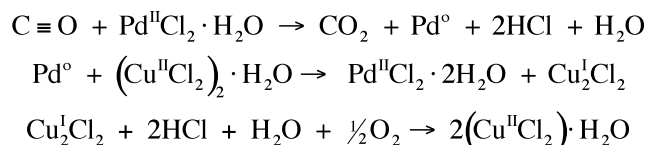

The NOVAX nano-gold catalyst was obtained with little information on its composition or manufacture. The producer is located in China. Most particles fall through a 20 mesh screen (manufacturer labeled 20×30), and the particles are irregularly shaped and pour freely. Granules are generally brown, but have orange tones.

Table 2. Properties of CO oxidation media evaluated.

MATERIAL	BULK DENSITY (g/cm ³)	PARTICLE SIZE (US Series)
Carulite 300	0.84	8x14
Dräger CAT	0.82	12x20
Modern Safety Technologies LT CAT	0.50	6x8
Novax Nanogold	1.31	-20
Ozone Solutions	1.01	6x8
STC Pt-SnO ₂	0.75	12x20
TDA catalyst	0.83	14x30

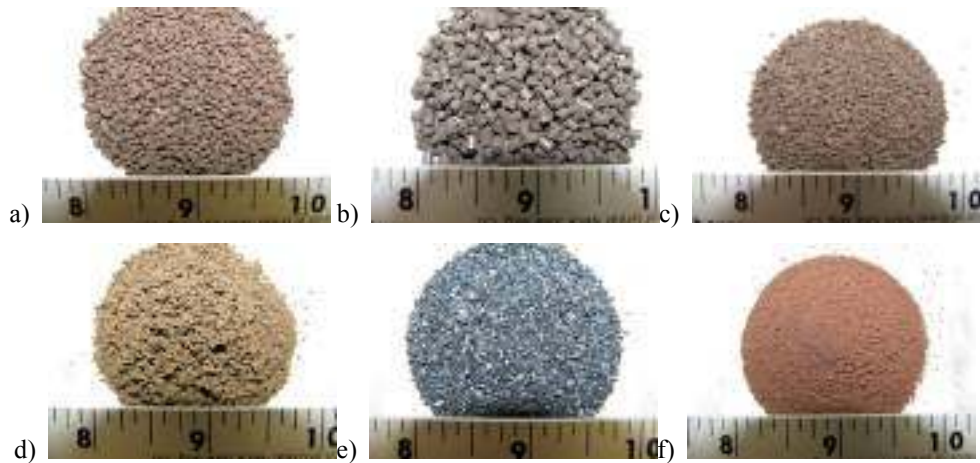

Figure 2. Materials evaluated to date for CO removal oxidation efficiency. *a) Carus Chemical Carulite 300, b) Ozone Solutions catalyst, c) Dräger X-plore mask cartridge AM/MA, d) TDA proprietary catalyst, e) STC Pt-SnO₂ catalyst f) NOVAX nano-gold catalyst. The catalyst from Modern Safety Techniques is shown in Figure 1 h). Scale markers are inches. The flash illuminated the particles, lightening the color.*

B. Evaluation of NH₃ Sorbents

1. Methods

The test set up incorporates a Picarro Cavity Ring Down Spectroscopy (CRDS) EnviroSense NH₃/CO₂/H₂O analyzer for NH₃ detection, and is depicted schematically and in photos by Figs. 3 through 5. A 500 ppm NH₃/N₂ calibration gas is mixed with high purity nitrogen to create mixtures containing 25 or 50 ppm NH₃. A mid-level humidity was desired to reflect a cabin condition, and was achieved by humidifying a portion of the nitrogen stream. The system was demonstrated to hold 40% relative humidity (RH) reliably for 7 days, so this was selected as the test RH. Some tests were run without the addition of water vapor.

The final mixture is routed through four parallel flow controllers that feed four catalyst/sorbent tubes. Tubes were 0.64 cm inner diameter, and the filled tubes were manually tapped for 3-5 minutes while held vertical, to settle the particles. A fine mesh screen contained the material at one end; quartz wool was used at the other end. In the test stand, tubes were installed horizontally. A back pressure regulator upstream of the four flow controllers enables the upstream controllers to control the contaminant mixture.

Typically one of the four tubes was empty; each of the others contained a different sorbent. This provided a periodic span reading (no removal of NH₃). The effluent from one tube at a time was routed to the detector for 20 minutes; the other three were simultaneously vented to exhaust. A macro was written to unravel the data to create data series for plotting.

2. Experimental Data

Fresh 1-gm samples, ‘as is’ from the package, were challenged with 25 and 50 ppm NH₃/N₂ mixtures, with and without 40% relative humidity. Plots of NH₃ loading versus time for all materials are shown below in Figs. 6 through 9. Final loading results calculated from the CRDS instrument are summarized in Table 3.

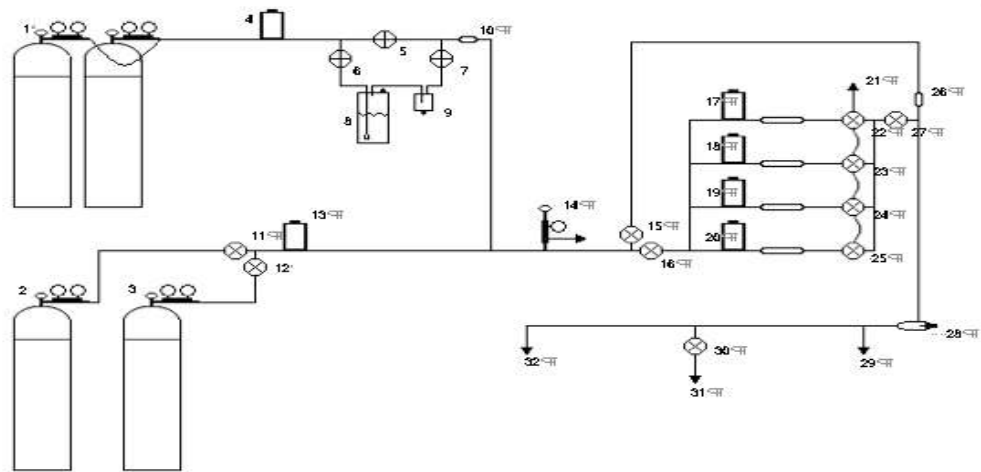

1	UHP Nitrogen (x2)	9	Water Trap	17	1000 sccm MFC (sample A)	25	Solenoid Valve, 3 way NC (open for Sample D effluent)
2	Ammonia in Nitrogen (500 ppm NH ₃)	10	Check Valve	18	1000 sccm MFC (sample B)	26	Check Valve
3	UHP Nitrogen	11	Solenoid Valve, 2 way NO (NH ₃)	19	1000 sccm MFC (sample C)	27	Solenoid Valve, 2 way NO
4	5000 sccm Mass Flow Controller (MFC)	12	Solenoid Valve, 2 way NC (N ₂)	20	1000 sccm MFC (sample D)	28	RH/Temperature Sensor
5	Needle Valve (for fine control of RH)	13	500 sccm Mass Flow Controller	21	Exhaust line	29	To CRDS for NH ₃ detection
6	Manual Valve (open for RH)	14	Relief Valve with gauge	22	Solenoid Valve, 3 way NC (open for Sample A effluent)	30	Rotary Valve to GC
7	Manual Valve (open for RH)	15	Solenoid Valve, 2 way NC	23	Solenoid Valve, 3 way NC (open for Sample B effluent)	31	To GC/NCD for NH ₃ detection
8	Stainless Steel Bubbler	16	Solenoid Valve, 2 way NO	24	Solenoid Valve, 3 way NC (open for Sample C effluent)	32	Tubing leads to atmospheric exhaust

Figure 3. Schematic of NH₃ sorbent evaluation test stand and components list.



a)

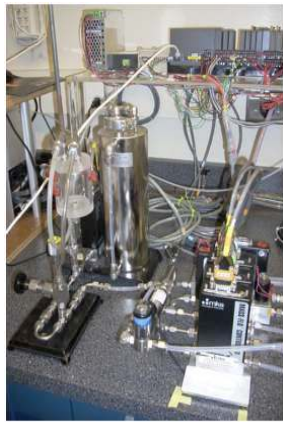

b)

Figure 4. Instrumentation. a) Picarro CRDS EnviroSense NH₃ analyzer; b) SS bubbler and parallel flow controllers for testing of 4 tubes simultaneously.

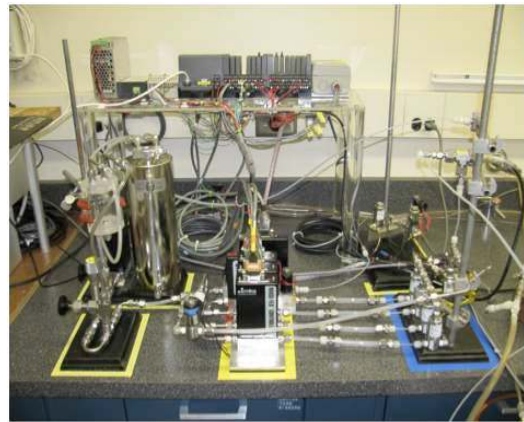

Figure 5. Another view of the test setup for NH₃ sorbent tests. A stainless bubbler, left, humidifies all or part of a nitrogen stream. Data acquisition modules at top; parallel flow controllers front/center (in yellow box). Valves lower right control which effluent is routed to the Picarro; others are vented.

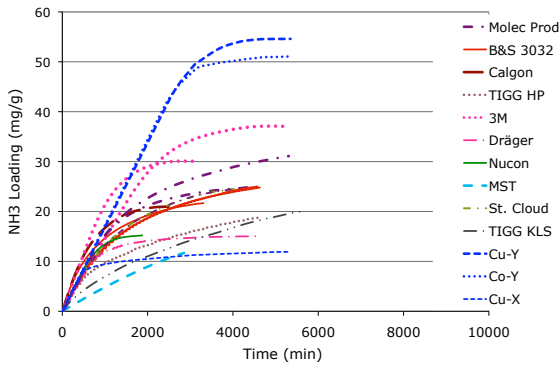

Figure 6. Loading of NH₃ on carbons and sorbents. 50 ppm dry

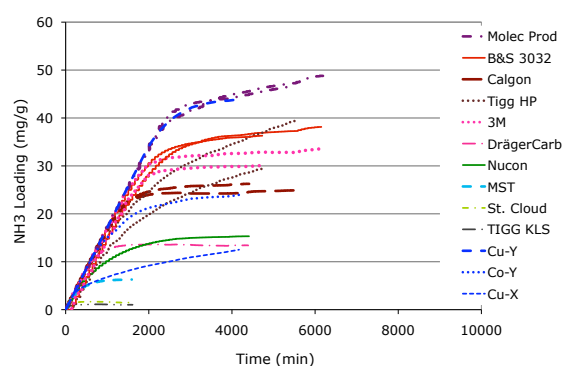

Figure 7. Loading of NH₃ on carbons and sorbents. 50 ppm wet

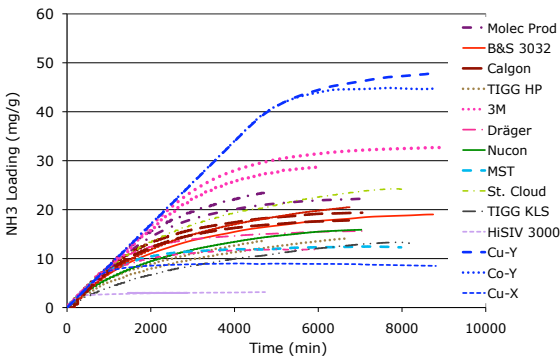

Figure 8. Loading of NH₃ on carbons and sorbents. 25 ppm dry

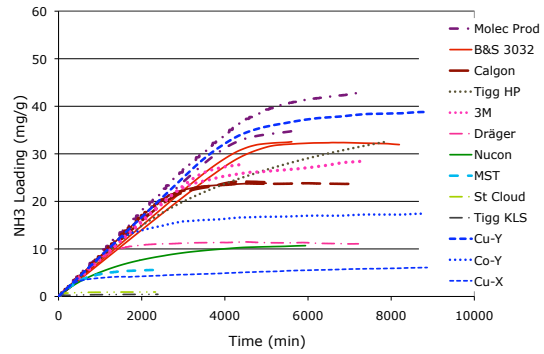

Figure 9. Loading of NH₃ on carbons and sorbents. 25 ppm wet

Table 3. Loading of NH₃ sorbents under 50 and 25 ppm NH₃ in N₂. Blue shaded boxes contain data from tests with 40% RH.

50 ppm NH ₃						25 ppm NH ₃							
Category	Material Name	Bulk Density (g/cc)	Particle Mesh Size	Sample Size (g)	CRDS Final Loading (mg/g)	Category	Material Name	Bulk Density (g/cc)	Particle Mesh Size	Sample Size (g)	CRDS Final Loading (mg/g)		
Phosphoric Acid-treated	Barnabey and Sutcliffe 3032	0.63	6x12	0.9905	21.9	Phosphoric Acid-treated	Barnabey and Sutcliffe 3032	0.63	6x12	0.9998	19.0		
				0.6600	21.7					1.0210	20.5		
				1.0188	24.8					1.0320	32.5		
				1.0005	37.8					1.0020	31.9		
				1.0020	36.3					0.9981	19.4		
	Calgon Carbon Ammonosorb II	0.67	6x12	0.9405	21.0		1.0090	17.8	Calgon Carbon Ammonosorb II	0.67	6x12	1.0030	24.0
				1.0430	19.3		1.0094	23.8					
				1.0172	24.9		1.0001	23.8					
				0.9907	26.8		1.0030	22.2					
				1.0008	24.9		1.0300	23.5					
	Molecular Chemsorb 1425	0.75	14x20	1.0160	29.9		1.0020	34.8	Molecular Chemsorb 1425	0.75	14x20	1.0020	34.8
				1.0025	46.7		1.0163	29.3					
				1.0028	48.6		1.0042	13.7					
				1.0128	18.9		1.0370	14.2					
				1.0160	19.6		1.0340	32.6					
TIGG HP	0.76	6x12	1.0044	39.5	1.0010	32.7	TIGG HP	0.76	6x12	1.0480	28.7		
			1.0890	29.5	1.0005	27.7							
			1.1067	37.0	1.0054	28.5							
			0.7177	30.1	0.9848	15.6							
			1.0031	36.2	1.0040	11.9							
Chloride-treated	3M 6004 Ammonia/Methylamine Cartridge	0.69	14x20	1.0170	30.1	Chloride-treated	3M 6004 Ammonia/Methylamine Cartridge	0.69	14x20	1.0186	11.1		
				1.0144	15.0					1.0010	10.0		
				1.0075	14.1					1.0386	15.9		
Nitrate-treated	Nucon Ammosorb I-3	0.70	6x8	0.9847	15.2	Nitrate-treated	Nucon Ammosorb I-3	0.70	6x8	1.0220	13.8		
				1.0302	15.9					0.9814	10.7		
Zeolites	St. Cloud Zeolite	0.90	12x16	0.9912	24.5	Zeolites	St. Cloud Zeolite	0.90	12x16	1.0110	24.4		
				0.9922	24.4					1.0360	0.9		
				0.9978	1.5					1.0101	12.9		
Catalyst	987 LTC Catalyst	0.47	6x8	3.7375	11.7	Catalyst	987 LTC Catalyst	0.47	6x8	0.9940	5.6		
				1.0583	6.3					1.0173	3.2		
Custom	Cu-Y	0.56	20x40	1.000	54.6	Custom	Cu-Y	0.56	20x40	1.000	47.9		
				1.010	43.9					1.010	38.8		
	1.000	51.1	1.003	44.7									
	1.008	24.0	1.025	17.4									
Custom	Co-Y	0.57	20x40	1.025	11.9	Custom	Co-Y	0.57	20x40	1.025	8.5		
				1.011	12.5					1.011	6.1		

3. Results

Under humid conditions, there is a more uniform, initial linear rise in loading for most of the sorbents; this is indicative of complete ammonia removal when the sorbents are fresh. This is not the case for the zeolites, whose ammonia removal is hampered by water vapor. Under dry conditions for most of the materials, the loading curve bends more diffusely and earlier than in the humid case, indicating ammonia in the effluent stream prior to reaching full capacity.

Conclusions concerning relative performance for NH₃ removal that can be drawn from the plots and tables are the following:

- 1) The custom, ion-exchanged Y-zeolite materials have a far higher capacity for ammonia removal than any of the commercial materials.

The following conclusions are drawn for the commercial materials, exclusive of the custom materials:

- 2) The Calgon material, the vendor's replacement for B-S Type 3032, demonstrated similar NH₃ capacity to Type 3032 under dry conditions, but lower overall capacity than B-S Type 3032 when the feed gas contained 40% relative humidity. At the 50 ppm NH₃ feed level with 40% RH, the final capacity of Ammonasorb II was ~30% lower than that of B-S Type 3032. At the 25 ppm NH₃ feed level with 40% RH, the final capacity of Ammonasorb II was ~25% lower than B-S Type 3032.
- 3) In dry nitrogen, the 3M carbon demonstrated the highest capacity for ammonia, reaching 37 mg/g in one test.
- 4) In nitrogen with 40% relative humidity, Molecular Products Chemsorb 1425 demonstrated the highest capacity for ammonia, ~48 mg/g in one instance.
- 5) Ammonia removal with the phosphoric acid impregnated carbons materials is higher when water vapor is present in the feed (40% RH).
- 6) The zeolites – St. Cloud, Tigg KLS and UOP HISIV – are relatively poor materials for ammonia removal under the conditions tested. Ammonia removal using zeolites is reduced in the presence of 40% relative humidity at room temperature.
- 7) Modern Safety Techniques 987 Low Temperature catalyst (LTCAT) is a comparatively poor NH₃ sorbent and its adsorptive capacity for NH₃ is lower in the presence of water vapor at 40% RH.
- 8) The carbons treated with chloride ion exhibit very different performance from each other. Dräger's material achieves about 1.5% NH₃ capacity by weight while 3M achieves loading on par with the H₃PO₄ impregnated carbons – about 3% by weight. The two carbons were tested in the same particle size distribution. There is no clear effect of water vapor on ammonia removal using the chloride-treated materials.
- 9) There is more complete removal of NH₃ initially under humid conditions, for the H₃PO₄ impregnated carbons and Modern Safety Techniques' 987 LT catalyst. These materials reach their loading capacity earlier under humid conditions.

C. Evaluation of CO catalysts at high CO concentration

1. Methods

The same test stand shown by Figs. 3 through 5 was used to evaluate CO oxidation catalysts. In this case the Picarro Cavity Ring Down Spectroscopy EnviroSense NH₃/CO₂/H₂O analyzer was used to detect CO₂, the product of CO oxidation. A 1000 ppm CO in air calibration gas was mixed with ultrapure nitrogen to create mixtures from 125 ppm to 1000 ppm.

Typically one of the four tubes was empty. This provided a zero reading (zero CO₂, or no oxidation). The effluent from one tube at a time was routed to the detector for 6 minutes; the other three are simultaneously vented to exhaust. For CO oxidation, the EnviroSense measures CO₂ in the stream post-catalyst, indicating the extent to which the inlet carbon monoxide has been oxidized.

The error in reading of the two flow controllers contributes to uncertainty in the final CO content of the mixture. Uncertainty is a percent of full scale, and necessarily higher when the CO calibration gas is a smaller fraction of the total mixture, at the lowest CO level. The three test tubes were filled with different masses of the same catalyst to evaluate the effect of contact time on CO oxidation.

2. Experimental Data

Results for room temperature CO oxidation are shown by Figs. 10 through 15. The CO content of the mixture was varied from 125 ppm to 1000 ppm in 125 ppm steps. There is higher uncertainty in the measurement concentration of the mixture at the lower concentrations; uncertainty stems from uncertainty in flow measurement and in calibration gas composition. Consequently, there is higher uncertainty in the calculated percent removed (CO₂ out/CO in) at the lowest concentration. Values over 100% for percent removed reflect this uncertainty.

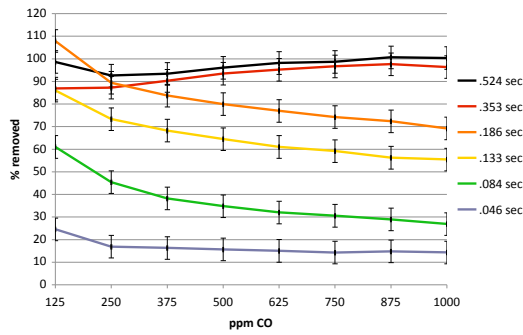

Figure 10. Oxidation efficiency of Carulite 300 catalyst. In dry air, at residence times from 0.05 to 0.5 second.

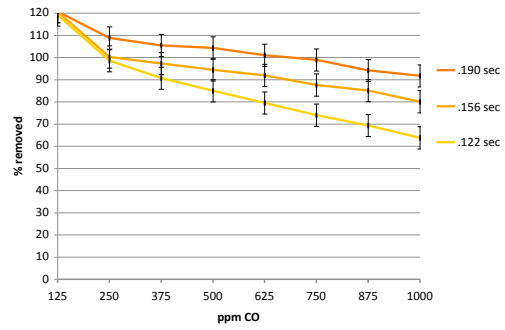

Figure 11. Oxidation efficiency of Dräger smoke hood catalyst. In dry air, at residence times from 0.12 to 0.19 second.

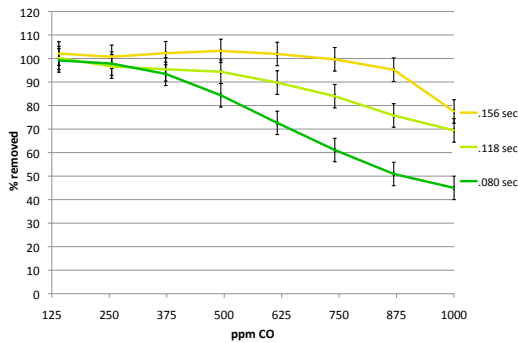

Figure 12. Oxidation efficiency of STC Pt-SnO₂ catalyst. In dry air, at residence times from 0.08 to 0.16 second.

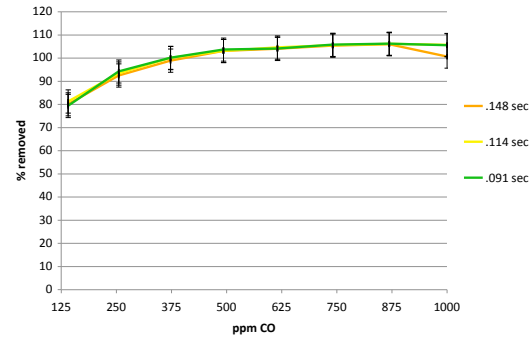

Figure 13. Oxidation efficiency of TDA Research proprietary catalyst. In dry air, at residence times from 0.1 to 0.15 second.

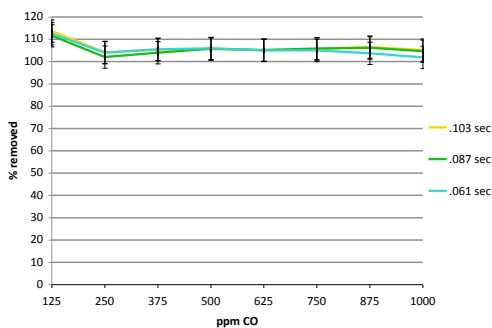

Figure 14. Oxidation efficiency of the NOVAX proprietary catalyst. In dry air, at residence times from 0.06 to 0.1 second.

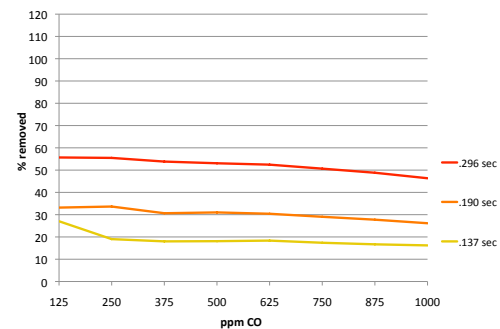

Figure 15. Oxidation efficiency of the Ozone hopcalite catalyst. In dry air, at residence times from 0.14 to 0.3 second.

3. Discussion of Results

The TDA Research and Novax products (Figures 13 and 14) offer the most efficient removal at the highest CO concentration tested, with 100% removal of 1000 ppm CO at contact times as low as 80-90 msec. These are the gold formulation catalysts procured in small particle sizes, and therefore would offer higher surface area and present greater pressure drop. STC and Dräger performances are next best, and comparable to one another (Figures 11 and 12). STC offers 100% removal at contact times as low as ~150 msec and CO levels to 875 ppm. At ~150 msec, the Dräger material offers full oxidation only to 250 ppm CO. Carulite 300, a hopcalite catalyst readily available, oxidizes CO fully at concentrations to 1000 ppm at superficial contact times over about 0.35 seconds as shown in Figure 10. The Ozone Solutions material is a poor CO oxidation catalyst under these test conditions, oxidizing only about half the CO at a contact time of 0.3 seconds (Figure 15).

D. Evaluation of CO Catalysts at low CO concentration

1. Methods

Gas from a clean air generator or from a NIST-certified calibration mixture (10 ppm CO in ultra pure air) was driven through a catalyst bed as shown below in Fig. 16. Gas could be humidified if desired, and sent directly to the detector or through the catalyst. A slipstream from the flow was pulled through a reduction gas detector at 50 sccm using a pump to satisfy the operating range of the detector (25-60 cc/min) while allowing both the bed and detector to operate at near ambient conditions. Before collecting data, a zero gas stream of the test humidity (dry or 50%RH) was pulled through the bed until the effluent was stabilized, that is, a stable zero measurement was obtained and the catalyst was no longer adsorbing or giving off water as measured by the humidity transmitters before and after the bed. This typically took over 4 hours and was more often accomplished overnight before a test.

The effluent level of CO was measured with a Trace Analytical reduction gas detector (RGD) with a voltage output signal. The RGD detector uses a heated mercuric oxide (HgO) reaction tube and a mercury (Hg) lamp in a heated ultraviolet (UV) detector cell. The UV detector cell is equipped with a UV photodiode. When a reducing gas such as CO enters the reaction tube, it reacts with the HgO to form gaseous Hg vapor, which is then swept into the UV cell. The gaseous Hg absorbs the UV light from the Hg lamp as it flows through the cell. The change in transmittance is converted by the data system into a voltage signal which is linearly proportional to the amount of reducing gas. Flow rate through the catalyst was varied from 50 sccm to 5000 sccm to quantify any effect of contact time on oxidation efficiency at this feed level. The flow rate was controlled by a program written in LabVIEW which allowed the user to step through the flow range in user defined increments and duration. The program also allowed the user to calibrate the system response at set intervals. For 4 of the catalysts, the experiment was repeated with double the quantity of catalyst.

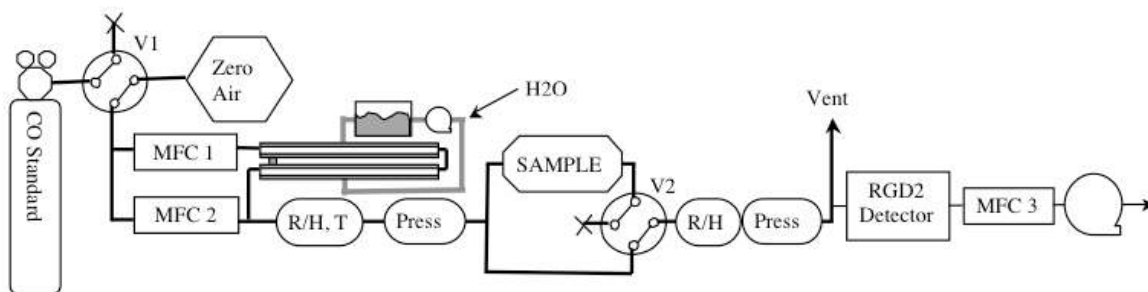

Figure 16. Test schematic for testing of ambient temperature catalysts at 10 ppm CO feed.

2. Experimental Data

Voltage signals from the RGD were converted to effluent CO levels; data are plotted below in Figures 17 and 18.

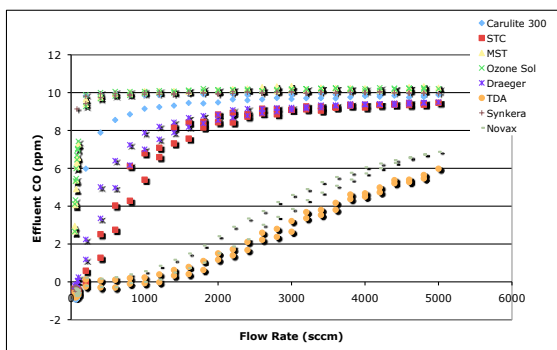

Figure 17. Oxidation efficiency of catalysts in dry air at 10 ppm CO as a function of flow rate.

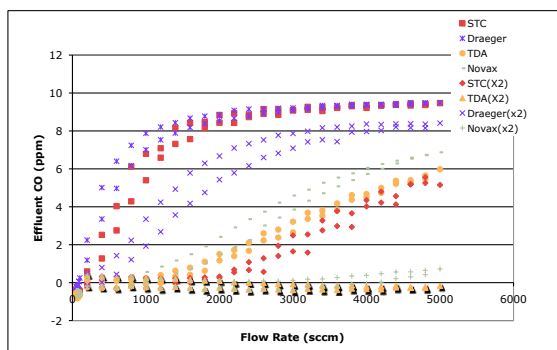

Figure 18. Oxidation efficiency of catalysts in dry air at 10 ppm CO as a function of flow rate. Catalyst mass doubled (x2)

3. Results

Consistent with the testing at high CO levels, at the 10 ppm level, TDA and Novax appear to be the superior catalysts for oxidation of CO in dry air (See Figure 17). This may be due to the smaller particle size and greater surface area of these materials, or due to the reaction mechanism on the gold catalyst surface. Modern Safety Techniques and Ozone Solutions offer almost no CO oxidation under the dry conditions tested.

It would be desirable to compare performance based on catalyst surface area. However, total surface area was not measured. An estimate can be made for the external surface area only, based on particle diameter. In order of decreasing average particle size and increasing external surface area, the materials are: Modern Safety Techniques, Ozone Solutions, Carulite, Draeger, TDA, STC and Novax. This is their general order of appearance from left to right on Figure 17, except that the last three are STC, Novax, and TDA. TDA performance is better than a simple external surface area calculation would suggest.

Relative comparisons can be made. For example, the average particle diameter of the STC particles can be approximated as ~ 0.9 mm, and the Novax average particle diameter can be approximated as ~ 0.42 mm, about half that of STC. External surface area can be considered inversely proportional to particle diameter, so the Novax material sample from Figure 17 offers double the external surface area of the STC sample. As shown in Figure 18, doubling the STC quantity, thereby doubling its surface area, provided oxidation equivalent to Novax. Nothing more precise can be done without quantitative surface area analysis. This will be pursued in the future.

All catalysts proved ineffective under the limited humid conditions tested to date; data are not shown.

III. Conclusion

Ammonasorb II carbon offers NH_3 capacity to the ISS carbon, B-S Type 3032, in dry gas. In the presence of water vapor at 40% RH, its capacity is lower by $\sim 30\%$. Molecular Products Chemsorb 1425 and carbon from 3M's ammonia mask cartridge remove ammonia as well as or better than B-S Type 3032 under all conditions tested. However, the materials were tested as manufactured, and these two materials are sold in a smaller particle size distribution, which would contribute to higher pressure drop. Presumably the pressure drop increase would be offset somewhat by a smaller bed. The commercial zeolites offer the poorest ammonia removal capacity, removing very little or none in the presence of water vapor. However, the selection of an appropriate sorbent for ammonia removal depends on its placement in the Atmosphere Revitalization System and on its ability to desorb. Downstream of a desiccant and for short adsorb cycles, a zeolite may provide adequate NH_3 removal. In a swing bed system, reversible adsorption is desirable. Multiple adsorb/desorb cycles will be pursued in the future to evaluate promising materials for use in a swing bed system. Although the primary goal of this effort was to evaluate commercial products for ammonia capacity, the Cu- and Co- ion-exchanged Y-zeolites, developmental sorbents, demonstrated the highest capacity for ammonia under the conditions tested. They warrant additional study since zeolites may provide reversible ammonia removal and could be used in a swing bed configuration.

The NOVAX gold catalyst and TDA's proprietary catalyst showed best CO oxidation performance at 1000 ppm level in dry air and at 10 ppm CO in dry air. Both of these catalysts are gold catalysts, but they were also tested in small particle size distributions. Total surface area for the promising catalysts should be quantified.

More thorough study of the most promising materials – ion exchanged zeolites for ammonia removal and the gold catalysts for oxidation – is warranted. In addition, testing with more constituents in the gas stream, multiple adsorb/desorb cycles for ammonia sorbents, and oxidation of other hydrocarbons by the catalysts will be pursued.

Acknowledgments

The authors thank Professor Arturo Hernandez-Maldonado for providing the ion-exchanged zeolites and for pelletization. G.S. and P.W. authors thank Exploration Systems Mission Directorate for internship support.

References

- ¹Perry, J. L., Cole, H. E., and H. N. El-Lessy. "An Assessment of the International Space Station's Trace Contaminant Control Subassembly Process Economics," NASA/TM-2005-214008, 2005, pp. 1-4.
- ²Wieland, P. O. "Living Together in Space: The Design and Operation of the Life Support Systems on the International Space Station., Vol. 1.," NASA/TM-1998-206956, 1998, pp. 147-152.
- ³*Ibid.*, p. 133.
- ⁴Lin, A., Smith, F., Sweterlitsch, J., nalette, T.A., and Papale, W. "Further Testing of an Amine-Based Pressure-Swing system for Carbon Dioxide and Humidity Control," SAE Paper 2008-01-2101, presented at the 38th International Conference on Environmental Systems, San Francisco, CA, June 29 – July 2, 2008.
- ⁵Luna, B., Ehresmann, D.J., Howard, D.J., Salas, L.J., Podolske, J.R., Mulloth, L., Perry, J.L., "Evaluation of Commercial Off-The-Shelf Ammonia Sorbents and Carbon Monoxide Catalysts," presented at the 38th International Conference on Environmental Systems, San Francisco, CA, June 29 – July 2, 2008, published in conference proceedings as SAE Paper No. 2008-01-2097.
- ⁶Tatara, J., Perry, J., and Franks, G. "International Space Station System-Level Trace Contaminant Injection Test," NASA/TM-1999-209010, 1999, pp. 24-28.
- ⁷James, J. T. "Spacecraft Maximum Allowable Concentrations for Airborne Contaminants," JSC-20584, 2008.
- ⁸Perry, J. L., Tomes, K. M., and Tatara, J. D. "Thermal Catalytic Oxidation of Airborne Contaminants by a Reactor Using Ultra-Short Channel Length, Monolithic Catalyst Substrates," NASA/TM-2005-214061, 2005.
- ⁹McKoy, K.M. Preparation and Characterization of a Low Temperature Oxidation Catalyst, Masters Thesis, University of Delaware, June 1984.
- ¹⁰Desai, M.N., Catalytic Oxidation of CO by Modified Wacker Catalyst, PhD Thesis, Northwestern University, June 1980.
- ¹¹Desai, M., Butt, J., and Dranoff, J. *Catalysis*, 79:95-103 (1983)
- ¹²Kawas, J., Oxidation Activity of Catalyst 3-7A, Toward Formaldehyde, Hydrogen Cyanide, Some Alkane Gases, Masters Thesis, Western Kentucky University, December 1982.
- ¹³Collins, M.F. (1986) Characterization of the LTC Catalyst: Performance Against Common Air Pollutants, Air Pollution Control Association Paper No. 86-43.3 presented at the 79th Annual Meeting of the APCA, Minneapolis, Minnesota, June 22-27, 1986.
- ¹⁴Collins, M.F. (1986) Room Temperature Catalyst for Improved Indoor Air Quality. *Ventilation '85*, Elsevier, 859-870.?
- ¹⁵Liu, C.Y., and Aika, K. Ammonia Adsorption on Ion-Exchanged Y-zeolites as Ammonia Storage Material. *Journal of the Japan Petroleum Institute*, 46(5): 301-307, 2003.
- ¹⁶Joshi, U.D., et al., Energetics of Ammonia Sorption in Alkali Metal Exchanged Analogues of Linde Type X Zeolites. *J. Phys. Chem. B.*, 105(443):10637-10647, 2001.
- ¹⁷Alptekin, G.O., Cates, M.C., Dubovik, M., and M.F. Cesario, "The Smoke Eater, A Sorbent/Catalyst for Recovery from Fires," SAE paper No. 2008-01-2098, presented at the 38th International Conference on Environmental Systems, San Francisco, CA, June 29 – July 2, 2008.
- ¹⁸Chen, B., C. Bai, R. L. Cook, J. Wright and C. Wang, "Gold/Cobalt-oxide Catalysts for Oxidative Destruction of Dichloromethane", *Catalysis Today*, 30, 15-20.
- ¹⁹Schryer, D. R., Schryer, J., Upchurch, B. T., and Kielin, E. J., (1991) "Catalytic Behavior of Noble Metal/Reducible Oxide Materials for Low-Temperature CO Oxidation. 1. Comparison of Catalyst Performance," *Langmuir*, 7:2135-2139.
- ²⁰Drawdy, J. E., Hoflund, G. B., Gardner, S. D., Yngvadottir, E., and Schryer, D. (1990) "Effect of Pretreatment on a Platinized Tin Oxide Catalyst Used for Low-Temperature CO Oxidation," *Surface and Interface Analysis*, 16:369-374.
- ²¹Gardner, S. D., Hoflund, G. B., Schryer, D. R., and Upchurch, B. T., (1991) "Characterization Study of Silica-Supported Platinized Tin Oxide Catalysts Used for Low-Temperature CO Oxidation Effect of Pretreatment Temperature," *J. Phys. Chem.* 95:835-838.
- ²²Drawdy, J. E., Hoflund, G. B., Davidson, M. R., Upchurch, B. T., and Schryer, D. R., (1992) "Characterization Study of Polycrystalline Tin Oxide Surfaces Before and After Reduction in CO," *Surface and Interface Analysis*, 169:559-564.
- ²³Herz, R. K., Badlani, A., Schryer, D. R., and Upchurch, B. T., (1993) "2 component Catalysts for Low-Temperature CO Oxidation, a Monte Carlo Study," *J. Catalysis* 141:219-238.
- ²⁴Schryer, D. R., Schryer, J., Upchurch, B. T. and Kielin, E., (1991) "Catalytic Behavior of Noble Metal/Reducible Oxide Materials for Low-Temperature CO Oxidation, 1. Comparison of Catalyst Performance," *Langmuir*, 7:2135-2139.

²⁵Gardner, S. D., Hoflund, G. B., Davison, M. R., Laitinen, H. A., Schryer, D. R., and Upchurch, B. T., (1991) "Behavior of Nobel Metal/Reducible Oxide materials for Low-Temperature CO Oxidation. 2. Surface Characterization of Au/MnO_x," *Langmuir*, 7:2140-2145(1991).