

Evolution of Flying Qualities Analysis: Problems for a New Generation of Aircraft

by

M. Christopher Cotting

Dissertation submitted to the Faculty of the
Virginia Polytechnic Institute and State University
in partial fulfillment of the requirements for the degree of

Doctor of Philosophy
in
Aerospace Engineering

Craig A. Woolsey, Chair
Wayne C. Durham, Co-Chair
Kenneth A. Bordignon
William H. Mason
Leigh S. McCue-Weil

March 29, 2010
Blacksburg, Virginia

Keywords: UAV, Flying Qualities, Flight Mechanics, Education

Copyright 2010, M. Christopher Cotting

Report Documentation Page

Form Approved
OMB No. 0704-0188

Public reporting burden for the collection of information is estimated to average 1 hour per response, including the time for reviewing instructions, searching existing data sources, gathering and maintaining the data needed, and completing and reviewing the collection of information. Send comments regarding this burden estimate or any other aspect of this collection of information, including suggestions for reducing this burden, to Washington Headquarters Services, Directorate for Information Operations and Reports, 1215 Jefferson Davis Highway, Suite 1204, Arlington VA 22202-4302. Respondents should be aware that notwithstanding any other provision of law, no person shall be subject to a penalty for failing to comply with a collection of information if it does not display a currently valid OMB control number.

1. REPORT DATE 29 MAR 2010	2. REPORT TYPE	3. DATES COVERED 00-00-2010 to 00-00-2010	
4. TITLE AND SUBTITLE Evolution of Flying Qualities Analysis: Problems for a New Generation of Aircraft		5a. CONTRACT NUMBER	
		5b. GRANT NUMBER	
		5c. PROGRAM ELEMENT NUMBER	
6. AUTHOR(S)		5d. PROJECT NUMBER	
		5e. TASK NUMBER	
		5f. WORK UNIT NUMBER	
7. PERFORMING ORGANIZATION NAME(S) AND ADDRESS(ES) Virginia Polytechnic Institute and State University, Doctor of Philosophy in Aerospace Engineering, Blacksburg, VA		8. PERFORMING ORGANIZATION REPORT NUMBER	
9. SPONSORING/MONITORING AGENCY NAME(S) AND ADDRESS(ES)		10. SPONSOR/MONITOR'S ACRONYM(S)	
		11. SPONSOR/MONITOR'S REPORT NUMBER(S)	
12. DISTRIBUTION/AVAILABILITY STATEMENT Approved for public release; distribution unlimited			
13. SUPPLEMENTARY NOTES			
14. ABSTRACT A number of challenges in the development and application of flying qualities criteria for modern aircraft are addressed in this dissertation. The history of flying qualities is traced from its origins to modern day techniques as applied to piloted aircraft. Included in this historical review is the case that was made for the development of flying qualities criteria in the 1940's and 1950's when piloted aircraft became prevalent in the United States military. It is then argued that UAVs today are in the same context historically as piloted aircraft when flying qualities criteria were first developed. To aid in development of a flying qualities criterion for UAVs, a relevant classification system for UAVs. Two longitudinal flying qualities criteria are developed for application to autonomous UAVs. These criteria center on mission performance of the integrated aircraft and sensor system. The first criterion is based on a sensor platform's ability to reject aircraft disturbances in pitch attitude. The second criterion makes use of energy methods to create a metric to quantify the transmission of turbulence to the sensor platform. These criteria are evaluated with airframe models of different classes of air vehicles using the CASTLE 6 DOF simulation. Another topic in flying qualities is the evaluation of nonlinear control systems in piloted aircraft. A L1 adaptive controller was implemented and tested in a motion based, piloted flight simulator. This is the first time that the L1 controller has been evaluated for piloted handling qualities. Results showed that the adaptive controller was able to recover good flying qualities from a degraded aircraft.			
15. SUBJECT TERMS			
16. SECURITY CLASSIFICATION OF:			17. LIMITATION OF ABSTRACT
a. REPORT unclassified	b. ABSTRACT unclassified	c. THIS PAGE unclassified	Same as Report (SAR)
			18. NUMBER OF PAGES 248
			19a. NAME OF RESPONSIBLE PERSON

Evolution of Flying Qualities Analysis: Problems for a New Generation of Aircraft

M. Christopher Cotting

Abstract

A number of challenges in the development and application of flying qualities criteria for modern aircraft are addressed in this dissertation. The history of flying qualities is traced from its origins to modern day techniques as applied to piloted aircraft. Included in this historical review is the case that was made for the development of flying qualities criteria in the 1940's and 1950's when piloted aircraft became prevalent in the United States military. It is then argued that UAVs today are in the same context historically as piloted aircraft when flying qualities criteria were first developed.

To aid in development of a flying qualities criterion for UAVs, a relevant classification system for UAVs. Two longitudinal flying qualities criteria are developed for application to autonomous UAVs. These criteria center on mission performance of the integrated aircraft and sensor system. The first criterion is based on a sensor platform's ability to reject aircraft disturbances in pitch attitude. The second criterion makes use of energy methods to create a metric to quantify the transmission of turbulence to the sensor platform. These criteria are evaluated with airframe models of different classes of air vehicles using the CASTLE 6 DOF simulation.

Another topic in flying qualities is the evaluation of nonlinear control systems in piloted aircraft. A \mathcal{L}_1 adaptive controller was implemented and tested in a motion based, piloted flight simulator. This is the first time that the \mathcal{L}_1 controller has been evaluated for piloted handling qualities. Results showed that the adaptive controller was able to recover good flying qualities from a degraded aircraft.

The final topic addresses a less direct, but extremely important challenge for flying qualities research and education: a capstone course in flight mechanics teaching flight test techniques and

featuring a motion based flight simulator was implemented and evaluated. The course used a mixture of problem based learning and role based learning to create an environment where students could explore key flight mechanics concepts. Evaluation of the course's effectiveness to promote the understanding of key flight mechanics concepts is presented.

*To my beautiful wife Lisa,
thank you for all your sacrifice
in making this possible.
I can't wait for our next adventure together!*

Acknowledgments

No work of significance can be accomplished by one person alone, and there have been many that have accompanied me on this journey of growth academically, personally, and professionally. First I would like to thank my God for fulfilling his promise to provide in all things; even when the bank account was low, the time was scarce, or my sanity was far from view. I would also like to express my love and gratitude for my wife, Lisa, who has selflessly sacrificed in supporting me while I pursued this degree. This degree is as much yours as it is mine. I also wish to thank my parents, Mac and Jeanne Cotting, who have always encouraged me to dream, and then supported me in chasing those dreams over many horizons.

I would like to express my gratitude to Dr. Wayne “Bull” Durham for giving me the opportunity to come to Virginia Tech. Teaching and developing the flight test course with you was the most fun I had while I was on campus, and I am grateful to have a chance to collaborate with you impacting the lives of students. I also appreciate your willingness to advise and assist me during your “retirement.” I am also very grateful to Dr. Craig Woolsey for taking me on as his student, and being willing to let me run in a direction that pushed both our limits. Your patience, candor, support, and enthusiasm has been a great help as I have worked towards this degree. Many thanks are in order to Dr. Bill Mason for giving me a place of T/A refuge in his design class. It has been a privilege to be able to tap into your wealth of knowledge of aircraft. I would like to thank Dr. Leigh McCue-Weil for encouraging me to pursue my education interests academically, and offering your support in fulfilling me degree. Thank you also to Dr. Ken Bordignon, who started this process by introducing

me to his old advisor, and then being supportive with long phone calls and flexible with time zone challenges.

I am very appreciative to John Hodgkinson for his willingness to review my work, his candid remarks, and giving me a voice in the flying qualities community. I would also like to thank NAVAIR PMA-262 and PMA-263 for their continued support of this and many other specification and standard development and update efforts within NAVAIR. In particular, Dr. Steve Cook, with the NAVAIR Airworthiness Team, and Jessica Holmberg in the Flight Dynamics Branch of Naval Air Systems Command, Patuxent River. Special thanks is due to Jessica Holmberg from NavAir for sponsoring my research on UAV flying qualities, and providing valuable direction, and to her branch head Steve Hynes for offering his input to the research. I would also like to thank the AOE department for its support in my piloted flying qualities research, and in providing my funding while conducting the flight test course. Thanks are also in order to Dr. Naira Hovakimyan for allowing me to use her \mathcal{L}_1 controller in my research, and to Dr. Chengyu Cao for his help in my implementation of the controller. I would also like to say a special thank you to Wanda Foushee and the ladies in the AOE office that have helped me navigate the required trail of paperwork in order to complete my degree.

Thanks are also due to Lt. Col. Bob Kraus for sharing an office, helping with the flight simulator, and providing his flight test pilot's experience to an engineer's questions. I would also like to thank all the students that have passed through the Nonlinear Systems Lab during my time at Virginia Tech. Especially thanks to Mark Monda for his help with the aircraft camera systems, Laszlo Techy for his help with the airdata boom, Justin Murtha for designing and building the SPAARO, Artur Wolek for his help in reducing flight test data, and Craig Sossi and Tyler Aarons for their help in keeping the SPAARO flying. Thanks also to Nina Mahmoudian and Amanda Dippold for their help and advice during my visits to the NSL.

I would like to offer a special thank you to Dr. David G. I. Kingston, and his wife Beverly for providing valuable mentorship to both my wife and me during our stay in Blacksburg. Finally, I would like to thank all the Navigators at Virginia Tech for allowing me a chance to share in your journey. It has been an honor to share this time with you.

“I don’t believe in mathematics.”

- Albert Einstein

Table of Contents

Acknowledgments	v
List of Figures	xiii
List of Tables	xviii
List of Symbols	xx
1 Introduction	1
2 Literature Review	5
2.1 History of Piloted Flying Qualities	5
2.2 Unmanned Air Vehicle Flying Qualities	10
2.2.1 The Case for Unmanned Air Vehicle Flying Qualities	10
2.2.2 Flying Qualities for UAVs	12
2.2.3 Current Work in UAV Flying Qualities	16
2.3 Nonlinear Control Flying Qualities	17
2.4 Teaching Flight Mechanics	19
3 Aircraft Equations of Motion	22

4	Review of Linear Systems	37
4.1	Transfer Functions	37
4.2	Definition of Bandwidth	41
5	Classification	44
5.1	Creating a Framework	45
5.1.1	Manned Aircraft Requirements Framework	45
5.1.2	Aerodynamic Effects on Aircraft Dynamics	47
5.2	Study of Available Aircraft	49
5.2.1	Sources of Data Considered	49
5.2.2	Results of Available Aircraft Study	49
5.3	Payload/Sensor Study	57
5.4	Conclusion	58
6	Review of Manned Flying Qualities	61
6.1	AFFDL-TR-T25, RPV Flying Qualities Design Criteria	62
6.2	MIL-F-8785C	63
6.3	MIL-HDBK-1797	68
6.3.1	LOES	68
6.3.2	Neal-Smith	72
6.3.3	Bandwidth	72
6.3.4	Time Domain Methods	79
6.4	SAE94900	80
6.5	NASA TN D-5153	83
6.6	ADS-33E-PRF	83
6.7	Conclusion	85
7	UAV Flying Qualities	87
7.1	UAV Criteria Guidance	87

7.1.1	Classification of Aircraft	88
7.1.2	Categorization of Flight Phases and Aircraft Maneuvers	88
7.1.3	Evaluation of UAV Task Performance	94
7.1.4	Applicable Manned Flying Qualities Criteria	94
7.2	Forming a New Criterion	98
7.2.1	Frameworks	98
7.2.2	Classical Bandwidth Compared to Flying Qualities Bandwidth	99
7.2.3	Accommodating MIMO Analysis	102
7.3	Proposed Criteria	102
7.3.1	A Simplified Pitch Criterion	103
7.3.1.1	Modeling	103
7.3.1.2	Algebraic Reduction	104
7.3.1.3	SISO Analysis Case	106
7.3.1.4	MIMO Analysis Case	110
7.3.2	A Criterion with Winds	113
7.3.2.1	Wind Effects	114
7.3.2.2	Energy Methods	115
7.3.2.3	Metrics	116
7.4	Simulation Trials	118
7.4.1	Simulation Testing	118
7.4.2	Aircraft Models	119
7.4.3	Sensor Model	120
7.4.4	Testing the Simplified Pitch Criterion	120
7.4.5	Testing the Wind Criterion	123
7.5	Conclusion	131
8	Nonlinear Flying Qualities	134
8.1	Introduction	135

8.2	Background	135
8.2.1	\mathcal{L}_1 Adaptive Control Architectures and Their Verification and Validation . .	135
8.2.2	Aircraft Model and SAS	138
8.2.3	Facility	138
8.2.3.1	Simulator	140
8.2.3.2	IADS	140
8.3	\mathcal{L}_1 Controller Implementation	142
8.4	Results	146
8.4.1	Predicted HQR of Plant Models	146
8.4.2	Simulation Traces (Linear and Nonlinear)	147
8.5	Piloted Simulation Trial	147
8.5.1	Piloted Task Definition	147
8.5.2	Simulation Trial Results	152
8.5.2.1	Task 1	152
8.5.2.2	Task 2	152
8.6	Open Issues in Prediction of Nonlinear Control Flying Qualities	155
9	Flight Mechanics and Flying Qualities in Engineering Education	157
9.1	Introduction	158
9.2	Combining Pedagogues	161
9.3	Technology Utilization	165
9.3.1	Student Immersion	165
9.3.2	Facility	166
9.4	Classroom Implementation	167
9.4.1	Course Goals and Objectives	167
9.4.2	Course Organization	170
9.4.3	Flight Testing Positions	172
9.4.3.1	Test Pilot	172

9.4.3.2	Flight Test Engineer (FTE)	174
9.4.3.3	Test Conductor	174
9.4.3.4	Discipline Engineer	174
9.4.4	Teaching and Student Participation	174
9.4.5	Using the Proper Vocabulary	176
9.4.6	Using Reference Books Instead of Textbooks	176
9.4.7	Team Building	177
9.4.8	Evaluation of Students; More Than Just Grades	178
9.5	Evaluation of Objectives	179
9.6	Conclusions	189
10 Conclusions and Recommendations		190
Bibliography		194
A Appendix: Self Assessment Surveys for AOE4984 Flight Test Techniques		211
A.1	Student survey	211
A.2	Post graduation	214
A.3	Employer	219

List of Figures

2.1	Timeline for flying/handling qualities development.	8
3.1	Body axis fixed coordinate system.	24
3.2	Aircraft symmetry in the X-Z plane.	26
3.3	Gravity vector in relation to aircraft body coordinates.	29
3.4	Angle of attack and angle of sideslip in relation to aircraft body coordinates.	31
3.5	Typical sign conventions for aircraft control surface deflections.	33
4.1	Basic block diagram example	38
4.2	Plot of the complex plane.	40
4.3	Example Bode diagram where $U(s) = \frac{\omega_n^2}{s^2 + 2\zeta\omega_n s + \omega_n^2}$	40
4.4	Example feedback block diagram reduction to single transfer function.	41
4.5	Example system diagram.	42
4.6	Example system diagram.	42
5.1	Operational aircraft comparison in user guide for MIL-F-8785B.	47
5.2	Aircraft operational comparison by Reynold's and Mach numbers.	51
5.3	Aircraft operational comparison by Reynold's and Mach numbers with manned aircraft classes overlaid.	51

5.4	Aircraft operational comparison by Reynold's number and weight.	52
5.5	Aircraft operational comparison by Reynold's number and weight with manned aircraft classes overlaid.	52
5.6	Aircraft operational comparison by Reynold's number and weight, with UA 2007 Roadmap Levels overlaid.	53
5.7	Aircraft operational comparison by Reynold's number and weight, with proposed UAV classes overlaid.	53
5.8	Aircraft operational comparison by Reynold's number and weight, with proposed UAV classes and trend lines overlaid.	54
5.9	JUAS COE classification boundaries as described in the 2009 Unmanned Systems Integrated Roadmap.	56
6.1	Natural frequency specification for Category B flight phases, MIL-F-8785C.	66
6.2	Example transfer functions to illustrate LOES.	69
6.3	Example transfer function time histories to illustrate LOES.	69
6.4	LOES boundaries for matching high order to low order transfer functions.	70
6.5	Pilot model used with Neal-Smith criterion.	73
6.6	Neal-Smith criterion for use in piloted aircraft with sample data.	73
6.7	Bandwidth longitudinal control block diagram.	76
6.8	Root locus longitudinal control diagram with bandwidth frequency.	76
6.9	Definition of bandwidth frequency, ω_{BW}	77
6.10	Bandwidth requirements from MIL Handbook.	77
6.11	Revised bandwidth requirements to aid in PIO prediction.	78
6.12	Definition of dropback by Gibson.	80
6.13	Relation of flight path angle and pitch attitude as shown by Gibson.	81
6.14	Definition of acceleration weighting function $w(f)$	82
6.15	Cooper Harper rating scale.	84

7.1 Proposed categories.	91
7.2 Flying qualities cycle	92
7.3 Mission task elements	93
7.4 A modified form of the Cooper Harper scale for use in sensor/UAV evaluation.	95
7.5 Definition of bandwidth frequency, ω_{BW} compared to the classical bandwidth definition.	100
7.6 Model used to approximate sensor and aircraft system.	105
7.7 Transfer function definitions used to define aircraft and sensor system	105
7.8 Reduced block diagram of sensor and aircraft system.	105
7.9 Angle descriptions for sensor and aircraft system.	106
7.10 Example of analysis of Equation (7.3).	108
7.11 Time history of SPAARO short period model and sensor using TARGET SISO model.	108
7.12 Bode plot of individual systems of the SPAARO short period and sensor model.	109
7.13 Time history of Cessna 172 short period model and sensor using TARGET SISO model.	110
7.14 Frequency analysis of SISO system for aircraft and sensor dynamics.	111
7.15 Time history of Cessna 172 short period model and sensor using TARGET SISO model with 1/6 system gain.	111
7.16 Frequency analysis of SISO system for aircraft and sensor dynamics.	112
7.17 Time history of Cessna 172 short period model and sensor using TARGET SISO model with 1/3 system gain.	112
7.18 Frequency analysis of SISO system for aircraft and sensor dynamics.	113
7.19 Interaction between sensor and aircraft	114
7.20 The influence of wind turbulence on aircraft motion and sensor errors.	115
7.21 An example of boundaries placed on χ for a pitch doublet MTE.	118
7.22 Bode comparison of sensor models with SPAARO aircraft dynamics.	121

7.23	Linear simulation comparison of sensor models with SPAARO aircraft dynamics, input at 1 rad/sec.	122
7.24	Linear simulation comparison of sensor models with SPAARO aircraft dynamics, input at π rad/sec.	122
7.25	CASTLE 6-DOF simulation of SPAARO with sensor model gain $K = 1$	124
7.26	CASTLE 6-DOF simulation of Cessna 172 with sensor model gain $K = 1$	124
7.27	CASTLE 6-DOF simulation of F-16 with sensor model gain $K = 1$	125
7.28	CASTLE 6-DOF simulation of all aircraft sensor pointing error.	125
7.29	Bode comparison of all aircraft with sensor model gain $K = 1$	126
7.30	Linear simulation comparison of all aircraft with sensor model gain $K = 1$, input excitation of π rad/sec.	126
7.31	χ calculation using CASTLE 6-DOF simulation of SPAARO with no turbulence.	128
7.32	χ calculation using CASTLE 6-DOF simulation of SPAARO with moderate turbulence.	128
7.33	χ calculation using CASTLE 6-DOF simulation of Cessna 172 with no turbulence.	129
7.34	χ calculation using CASTLE 6-DOF simulation of Cessna 172 with moderate turbulence.	129
7.35	χ calculation using CASTLE 6-DOF simulation of F-16 with no turbulence.	130
7.36	χ calculation using CASTLE 6-DOF simulation of F-16 with moderate turbulence.	130
8.1	\mathcal{L}_1 adaptive control architecture.	136
8.2	Augmented F-16 Plant.	139
8.3	Diagram of Virginia Tech Flight Simulation System.	141
8.4	Sample IADS [®] data screens used for the study.	143
8.5	Block diagram of \mathcal{L}_1 controller.	144
8.6	MIL-F-8785C Short Period Criteria.	148
8.7	Doublet command used to test \mathcal{L}_1 controller response.	149
8.8	Doublet short period response with \mathcal{L}_1 controller.	150

8.9	Pilot's view for pitch capture task.	151
8.10	Piloted Cooper Harper Ratings Results.	153
9.1	First page of Laboratory 1 flight test cards.	171
9.2	Illustration of flight test tasks/stations.	173

List of Tables

3.1	Variable definitions for transfer functions found in Equation (3.69) - Equation (3.73).	36
5.1	Manned aircraft classifications as defined in MIL-F-8785C.	46
5.2	Manned aircraft Flight Phase Categories as defined in MIL-F-8785C.	46
5.3	Definition of classification separation lines.	55
5.4	Aircraft (manned and unmanned) used in comparison	57
5.5	Sample payloads found in research for this report	59
5.6	Payloads from Table 5.5 reduced to general classes.	60
6.1	Gain and phase margin requirements as defined in AS94900.	81
6.2	Probability of exceedance of ride discomfort indices (vertical and lateral) in AS94900.	82
7.1	Flight Phases as defined in MIL-F-8785C.	90
7.2	Example maneuvers for proposed categories.	91
7.3	Aircraft operational points used for testing in simulation.	119
8.1	Reference of vehicle states.	139
8.2	Test Flight Cases	139
8.3	Reference of \mathcal{L}_1 parameters.	146

8.4 Cooper Harper Ratings from Flying Qualities Test of \mathcal{L}_1 controller augmenting Short Period.	153
--	-----

List of Symbols

α	angle of attack
\bar{c}	mean aerodynamic chord
\bar{q}	dynamic pressure
β	aircraft sideslip
χ	energy based flying qualities metric
$\ddot{\theta}$	pitch acceleration
$\Delta\delta$	change in horizontal control surface deflection
$\Delta\delta_e$	change in aircraft elevator position
Δn_{ss}	change in steady state n_z
δ_e	elevator position
$\frac{d\mathbf{H}}{dt}$	change in angular momentum with respect to time
$\frac{d\mathbf{p}}{dt}$	change in linear momentum with respect to time
\dot{h}	aircraft sink rate

γ	flight path angle
$\omega_{\text{bw_gain}}$	Definition of gain frequency for flying qualities bandwidth
$\omega_{\text{bw_phase}}$	Definition of phase frequency for flying qualities bandwidth
ω_{bw}	Classical definition of bandwidth frequency
ω_{sp}	short period natural frequency
ϕ	aircraft roll attitude
$\phi_u(f)$	Von Karmen gust power spectral density of intensity specified in MIL-STD-1797
ψ	aircraft yaw attitude
ρ	air density
τ	pilot delay
τ_e	equivalent time delay
τ_{p1}	pilot lead compensation
τ_{p2}	pilot lag compensation
τ_p	phase delay approximation for equivalent time delay τ_e
θ	pitch attitude
θ_{Target}	pitch angle from aircraft to the target
$\theta_{a/cc}$	aircraft pitch attitude command
θ_{ac}	aircraft pitch attitude from inertial to body axis
θ_{cs}	sensor pitch attitude command
θ_c	pitch attitude command

θ_{err}	pitch angle pointing error used in χ metric
θ_e	pitch attitude error
θ_{sensor}	sensor pitch attitude from inertial to body axis
$\mathbf{F} = \langle F_x, F_y, F_z \rangle$	inertial space coordinate vector
$\mathbf{V}_i = \langle \mathcal{U}, \mathcal{V}, \mathcal{W} \rangle$	inertial frame velocity vector
ζ_{sp}	short period damping ratio
a_z	aircraft vertical acceleration
C_{L_sens}	closed loop sensor transfer function
C_{L_SP}	closed loop short period transfer function
$C_{L\alpha}$	lift curve slope, $\frac{\partial C_L}{\partial \alpha}$
C_L	coefficient of lift
$C_{m\delta}$	longitudinal control power, $\frac{\partial C_m}{\partial \delta}$
$C_{m\dot{\theta}}$	damping derivative, $\frac{\partial C_m}{\partial \frac{\dot{\theta}}{2V}}$
C_{mC_L}	static margin
C_m	pitching moment coefficient
D_i	ride discomfort index
E	aircraft energy
E_h	energy height
f	frequency Hz
f_m	mode frequency in Hz(FCS engaged)

f_t	truncation frequency
g	acceleration due to gravity
g	acceleration due to gravity
G_{sens}	open loop sensor transfer function
G_{SP}	open loop short period transfer function
h	aircraft altitude
I_{yy}	pitch moment of inertia
K	variable used for a gain
K_p	pilot model gain
K_p	pilot pitch gain
L	aircraft rolling moment
L_α	dimensional form of C_{L_α}
l_t	tail moment arm
M	aircraft pitching moment
m	vehicle mass
m	vehicle mass
M_{δ_e}	change in pitching moment with respect to elevator deflection.
$M_{\dot{w}}$	change in pitching moment with respect to vertical acceleration.
M_w	change in pitching moment with respect to vertical speed.
N	aircraft yawing moment

n_α	aircraft load factor per angle of attack
n_z	vertical acceleration or aircraft loading
P_s	specific excess power
$range_{err}$	virtual distance error used in χ metric
S	aircraft wingspan
s	$s = \sigma + i\omega$, Laplace integration variable
T_{θ_2}	pitch numerator time constant for short period approximation
$T_{cs}(f)$	transmissibility, at crew station, $\frac{g}{ft/sec}$
u	aircraft body axis forward velocity
V	magnitude of aircraft velocity
v	aircraft body axis size velocity
V_{0max}	maximum operational airspeed (MIL-STD-1797)
V_{0min}	minimum operational airspeed (MIL-STD-1797)
V_1	limit airspeed (MIL-A-8860)
V_t	aircraft true velocity
W	aircraft weight
w	aircraft body axis vertical velocity
$w(f)$	acceleration weighting function per g
Z_{δ_e}	change in height with respect to elevator deflection
Z_w	change in height with respect to vertical speed.

6 DOF Six Degree of Freedom

V_{ex} vehicle exhaust velocity

APC aircraft pilot coupling

CAP control anticipation parameter

FCS flight control system

GM gain margin, the minimum change in loop gain, at nominal phase, which results in an instability.

JUAS COE Joint Unmanned Aircraft Systems Center of Excellence

LOES low order equivalent system

Mode A characteristic aeroelastic response of the aircraft as described by an aeroelastic characteristic root of the coupled aircraft/FCS dynamic equation of motion.

MTE mission task element

MUAD maximum unnoticeable added dynamics

NACA National Advisory Committee on Aeronautics

NAS national air space

PBL Problem Based Learning

PIO pilot induced oscillation

PM phase margin, the minimum change in phase, at nominal loop gain, which results in an instability.

RPV remotely piloted aircraft

STEMS standard test evaluation maneuver set

UAV uninhabited (unmanned) aerial vehicle

Chapter 1

Introduction

ATMOSPHERIC flight mechanics is an applied discipline that draws together many of the theoretical and fundamental sciences often associated with pure research.¹ Unlike classical mechanics, fluid dynamics, or basic control system theory which all have foundations where fundamental research can be a rich topic, atmospheric flight mechanics seeks to find work done in fundamental research and apply that work to air vehicles. The research in atmospheric flight mechanics therefore involves finding work done in other more fundamental disciplines, and then applying it to the special case of air vehicles. The research in atmospheric flight mechanics has often been driven by problems found in the application of fundamental research to the air vehicles. Examples of this are numerous, but can be traced to the formation of the discipline of aircraft stability and control that was formed by Lancaster² and Bryan.^{3,4} They have been credited with the foundation of aircraft stability and control which made possible the application of control techniques to aircraft, and ultimately the discipline of aircraft flying qualities. Aircraft flying qualities can be defined as the measuring of the aircraft's dynamic response to a command. Their specification is "intended to assure flying qualities that provide adequate mission performance and flight safety regardless of design implementation or flight control system mechanization."⁵

For this reason the study of flying qualities has often lagged behind fundamental research in other

fields as well as aircraft design innovation. Flying qualities research exists to ensure the application of new technology to an air vehicle will either enhance or not impede the operation of the aircraft to accomplish a desired mission. The new innovations that increase an aircraft's operational ability must still fall within either a pilot's or an operator's ability to control an aircraft. Therefore, the role of flying qualities is to quantify an aircraft's performance so that its suitability to a task can be judged. Believing that no further study of flying qualities was warranted in the application of current technology to aircraft, the USAF declared flying qualities a sunset science in the 1980s, and ceased significant research into flying qualities of aircraft. The occurrence of the YF-22 PIO soon after this declaration proved that there was still plenty to be learned about human / aircraft interface when new technology is applied to aircraft. Continued work in PIO prediction and performance has continued, but no emphasis on revision of flying qualities standards to keep pace with modern advances in aircraft has been made. This work defines two current areas where flying qualities standards must be changed to keep pace with the application of modern technology to aircraft. Specifically the areas are in dealing with nonlinear control theory, and a revolutionary change in the aircraft paradigm, unmanned aerial vehicles (UAVs).

This dissertation first provides a historical overview of flying qualities development. It then illuminates the current need for a flying qualities criterion for UAVs. A review of currently used manned flying qualities standards is given, with the motivation of finding modifications to them to be used for UAVs. A flying qualities standard for use in specifying longitudinal performance in airplanes like UAVs is then presented. Flying qualities as applied to manned vehicles using nonlinear control is also addressed. Many open problems in this area still exist, and this dissertation gives an example of one controller that is applied and tested in a flight simulation. Finally current issues in flight mechanics education are addressed. Modern teaching techniques are explored in augmenting a curriculum with relevant flight mechanics problems to encourage students to study flight mechanics and the field of flying qualities.

The contributions of this work to the state of the art in flight mechanics and flying qualities touch

on several areas in this field. They are as follows:

- A classification standard for UAVs is proposed. This standard would be used in a similar way as the standard first used in MIL-F-8785B.⁶ This classification standard allows for weight and the aircraft's operational flight envelope to be used in classifying UAVs for flying qualities testing, whereas current military classifications only rely on gross takeoff weight to classify aircraft.
- Two longitudinal flying qualities criteria are proposed for autonomous UAV operation. While previous criteria have been proposed in literature for RPVs, only the modification of previous piloted criteria boundaries have been proposed. These two proposed criteria in this work use the heritage of piloted flying qualities criteria as a starting point, but then derive new criteria specifically for autonomous UAVs. The new criteria focus on the interaction of the aircraft and payload sensor package to judge overall mission performance. Specifically one criterion focuses on the short period interaction with sensor performance, and the other is a metric to account for both short period and phugoid interaction with sensor performance in the presence of turbulence.
- A nonlinear adaptive controller was implemented in the Virginia Tech manned flight simulator, and then evaluated. This was the first time that the \mathcal{L}_1 controller was flown by a pilot and evaluated for flying qualities. The study was done to investigate the ability of current piloted evaluation techniques for use in evaluation of a nonlinear adaptive controller. The study showed the the recovery of good longitudinal flying qualities by the \mathcal{L}_1 controller when a degraded aircraft model was being controlled.
- A new approach to teaching flight mechanics was successfully implemented by Dr. Wayne Durham and the author. By using a full motion flight simulator, flight testing techniques were

taught to aerospace engineering seniors as a capstone course in flight mechanics. The course was able to foster deep learning by reinforcing previously covered concepts, and introducing new, relevant concepts to the students while employing nonconventional methods of student engagement. The course received overwhelmingly successful reviews by the students both after the course and after they had entered the workplace. Their employers further endorsed the course as a means for accelerating the students integration into the workforce.

Literature Review

IN 1908 the United States Army issued a sole source procurement specification to Orville and Wilbur Wright for the first purchase of an airplane for military use. That specification stated that “It should be sufficiently simple in its construction and operation to permit an intelligent man [sic] to become proficient in its use in a reasonable length of time.”⁷ While that statement still holds true for modern day aircraft, the criteria defining the words “sufficiently simple,” “proficient,” and “reasonable length of time” must be precisely defined. These definitions have evolved over time to reflect the complexities that have arisen from advancing aircraft designs. A new round of evolutionary changes has occurred in aircraft design. This evolutionary change has removed the pilot from the aircraft creating a new paradigm known as unmanned air vehicles (UAVs), or unmanned aerial systems (UAS). This literature review traces the development of flying qualities for piloted aircraft, and then makes an argument for the need of flying qualities criteria for unmanned aircraft.

2.1 History of Piloted Flying Qualities

Aircraft flying qualities design specifications are “intended to assure flying qualities that provide adequate mission performance and flight safety regardless of design implementation or flight control

system mechanization.”⁵ These specifications are intended to address problems that were originally identified before the first airplane took flight.⁸ Chanute compiled a list of ten problems that he identified as needing to be overcome before an aircraft could be successfully operated. Three of his listed ten problems were directly related to what we now classify as flying qualities: (1) the maintenance of equilibrium (or trimmed flight), (2) the guidance in any desired direction (controlled flight), (3) the alighting safely anywhere (landing). The Wright brothers heeded this advice, and spent considerable time flying gliders to understand the nuances of aircraft controllability before flying their first powered aircraft.⁹ While addressing the Western Society of Engineers in 1901, Wilbur Wright stated:

“Men already know how to construct wings or aeroplanes which when driven through the air at sufficient speed, will not only sustain the weight of the wings themselves, but also that of the engine, and the engineer as well. Men also know how to build engines and screws of sufficient lightness and power to drive these planes at sustaining speed...Inability to balance and steer still confronts students of the flying problem ... When this one feature has been worked out, the age of flying machines will have arrived, for all other difficulties are of minor importance.”¹⁰

The Wright’s ability to confront and solve this problem led them to be the first successful aircraft manufacturer. The importance of controllability was not lost on their first customers as well. When the U. S. Army contracted the Wright brothers to manufacture the first aircraft for military use, requirement 10 in their specification addressed the need for operational simplicity so that an intelligent man could be quickly trained.⁷ Widely regarded as the first flying qualities requirement for aircraft, it is still relevant to today’s aircraft.¹¹

The first formal work in flying qualities analysis was performed by the National Advisory Committee on Aeronautics (NACA) . The initial work was done by Soulé to determine the instrumentation and techniques required to measure aircraft flying qualities.¹² Gilruth¹³ continued this work, and wrote what is acknowledged as the first technical flying qualities specification for the

NACA in 1943. This specification was mirrored by similar documents by the U. S. Army and Navy.^{14,15} These early documents reflected a need to be specific in aircraft requirements, as the number of aircraft being procured by the military increased due to the war effort. A desire to have uniformly flying aircraft was predicated by the desire to have a uniform pilot training program. With the large quantity and variety of aircraft being procured for the war effort, the armed forces recognized that pilot training efforts could be streamlined if all aircraft were operated in a similar manner, and all aircraft responded to pilot control within given guidelines. Shortly after the conclusion of World War II, the first multi-service flying qualities document was issued.¹⁶ MIL-F-8785 was the beginning of modern flying qualities documents in that for the first time desired aircraft dynamic responses were specified, and all military services agreed upon a unifying standard. The aircraft dynamic responses were quantified with natural frequencies and damping ratio targets for the short period, phugoid, dutch roll, and spiral modes. A detailed timeline of the evolving flying qualities specifications can be found in Figure 2.1.

In 1948 flying qualities research transitioned from its infancy into the modern era of analytical work. During this time frame technology expanded in many fields directly affecting aircraft including propulsion, materials, control systems, and analytical techniques. The speed and altitude capabilities of aircraft saw a significant increase and aircraft configurations began to move in very different directions. During this time Cornell Aeronautical Laboratory began experimenting with variable stability aircraft. Work was also done in the area of control anticipation parameter (CAP), which specifies the aircraft's pitch acceleration to change in steady state load factor. These advances coupled with the onset of the Korean War led the U. S. Air Force and Navy to collaborate on the MIL-F-8785 in 1954^{11,17}.

As advances to aircraft technology allowed for varied uses, distinguishing characteristics of broad categories of aircraft became apparent. These broad categories of aircraft dictated different requirements for each category, and led to revisions of MIL-F-8785¹⁸ with a final version of MIL-F-8785C⁵

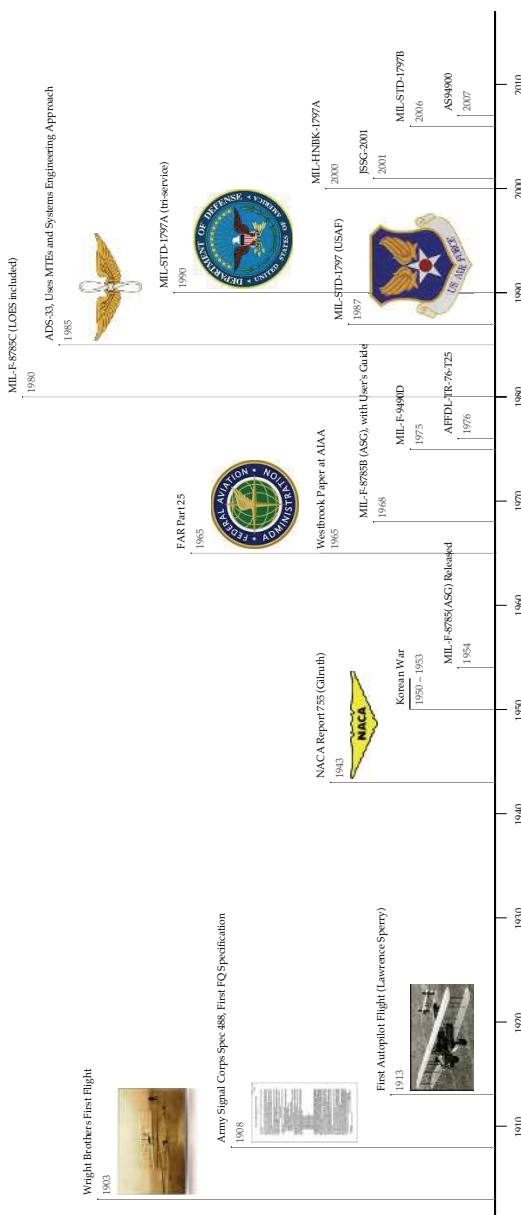

Figure 2.1: Timeline for flying/handling qualities development.

(Wright Flyer), http://en.wikipedia.org/wiki/File:First_flight2.jpg, 2010, public domain.

(Army Signal Corps Specification No 486), <http://www.ascho.wpafb.af.mil/birthplacePG14-1.HTM>, 2010, fair use.

(Sperry Autopilot Aircraft), <http://www.historynet.com/lawrence-sperry-autopilot-inventor-and-aviation-innovator.htm>, 2010, public domain.

(NACA), http://www.dfrc.nasa.gov/Gallery/graphics/Logos/HTML/NACA_logo.html, 2010, fair use.

(FAA), <http://www.faa.gov>, 2010, fair use.

(U. S. Army Aviation), <http://www.army.mil/info/organization/rucker>, 2010, fair use.

(U. S. A. F.), <http://upload.wikimedia.org/wikipedia/commons/002/Usaf.png>, 2010, public domain.

(U. S. Department of Defense), <http://www.af.mil/artmediagallery.asp?galleryID=4979>, 2010, fair use.

in 1980. This final version of MIL-F-8785 was considered controversial because it did not contain guidance for the emerging class of digitally controlled aircraft.¹¹ The MIL-F-8785C specification was notable, however, for first containing the low order equivalent system (LOES) approach to evaluating complex aircraft control systems. The LOES approach gives guidelines for pilot input to aircraft response in the form of transfer functions that are simplified models of the total aircraft response. By matching an aircraft's response to a known, good LOES response an aircraft is predicted to have favorable flying qualities. Good LOES response aids in predicting favorable margins for dynamic stability.¹⁹ Aircraft dynamic stability prevents unintentional excursions into dangerous flight regimes. The stable aircraft, which is predicted by meeting flying qualities specifications is also resistant to external forces such as wind that may require added pilot compensation. "These characteristics not only improve flight safety, but allow the pilot to perform maneuvering tasks with smoothness, precision, and minimum effort."²⁰ By following piloted flying qualities criteria an aircraft designer can aid the pilot in maximizing aircraft mission effectiveness while minimizing safety concerns to the pilot during flight.

While advances in technical specifications progressed, the final test of flying qualities remained the subjective judgement of the aircraft operator. Unlike performance requirements for aircraft, flying qualities specifications are a design guideline used as a means to achieve an end, and are not an end unto themselves. As stated by Vincenti: "Thus, *for the designer*, the quantities set down in performance specifications are themselves *objective ends*; the quantities prescribed in specifications of flying qualities are *objective means* to an associated *subjective end*."²¹ In the 1980s government procurement underwent a change in philosophy from specifying "hard and fast" requirements to providing guidance to designers, and allowing aircraft designers to make final decisions on criteria that were applicable to their specific aircraft.¹¹ In an effort to reflect new trends in military acquisition, a new standard MIL-STD-1797²² was released. This new standard incorporated standards in MIL-F-8785C, but also included flight test methodologies, and a pilot opinion rating scale that had been widely used but not officially adopted. Known as the Cooper-Harper Rating Scale,^{23,24} it

allowed for a less stringent “pass/fail” criterion in judging aircraft. MIL-STD-1797 also reflected a change from specific requirement to design guidance allowing requirements to be customized for each aircraft. MIL-STD-1797 included guidance from research conducted in the 1970’s and 1980’s regarding digital control for aircraft, although at the time no one criterion was found that could be applicable to all aircraft. LOES specifications that were first presented in MIL-8785C were considered controversial and suggested revisions were made to begin to account for time delay effects of digital control systems.²⁵ Specifically the Neal-Smith database²⁶ had brought to light these issues with flight testing of various aircraft. This database was later augmented by further research by Smith into time delay and its effect on flying qualities.^{27,28} MIL-STD-1797 brought revisions to the LOES specifications as well as other suggested criteria to deal with the previously mentioned time delay issues. As well as including references to the Neal-Smith database and work by Smith and Geddes, it also suggested criteria based on pitch bandwidth,²⁹ and a mixed frequency and time based criterion.³⁰ MIL-STD-1797 was reissued in 2000 as MIL-HNBK-1797 further underscoring the change in criteria from a requirements document to a design guidance document. The specifications were again amended, primarily to reflect further acquisition strategy changes in 2002.³¹ These changes reflected a desire by procurement agencies to keep up with the ever changing and more complex aircraft that were being designed for manned operation. Their intent, however, was still the same: “to assure flying qualities that provide adequate mission performance and flight safety regardless of design implementation or flight control system mechanization.”²²

2.2 Unmanned Air Vehicle Flying Qualities

2.2.1 The Case for Unmanned Air Vehicle Flying Qualities

The use of unmanned aircraft has risen sharply since the end of the Cold War.³² The future use of both military and civilian unmanned aircraft is projected to increase sharply. Technological limits that previously required aircraft to be controlled by pilots no longer exist, and barriers to unmanned

aircraft are ones of logistics and ensuring mission capability.^{33,34} The Department of Defense (DoD) expects to have over 400 UAVs operating in the field, investing over \$10 billion in their use. The DoD expects to be operating full scale aircraft as UAVs by 2012. Advantages of UAVs to manned systems include the “dull, dirty, and dangerous” jobs where exposure of human life is either considered too costly or unsafe. The DoD has identified the goal of “Decreasing the annual mishap rate of larger model UAVs to less than 20 per 100,000 flight hours by FY09 and less than 15 per 100,000 flight hours by FY15.”³³

Procurement costs are considered a major influence in choosing UAVs over traditional manned aircraft. The aviation industry recognizes an informal rule that the production cost of an aircraft is directly proportional to its empty weight. That figure is currently \$1500 per pound (FY94 dollars). Ten to fifteen percent of a manned aircraft’s empty weight is allotted to pilot systems (cockpit, ejection seat, etc.). Unmanned aircraft do not need these systems and pose a savings based on reduced weight alone. Although these systems may still be present in the form of ground control stations, they are usable for more than one UAV and are not considered lost in the event of an aircraft incident. Additional savings can be found in that most manned aircraft systems spend a majority of their “combat life” in training scenarios keeping pilots proficient. Modern strike aircraft spend 95% of their 8000 hour in-flight life in conducting training scenarios, and only 400 hours in-flight supporting combat operations. Current UAV designs for strike aircraft are focused on a 4000 hour in-flight life where little to no in-flight training time is required. UAV ground control stations can be used with modern flight simulators to provide high fidelity training without flying the UAV itself. Seventy-five percent of non-combat aircraft losses are attributed to human error. While pilots augment their training with simulation, no substitute is currently available for a pilot flying an aircraft in training scenarios. With UAVs, however, since the pilot is not present in the aircraft, simulation becomes a much more viable alternative for training, and reduces the exposure of airframes to loss during training scenarios.³³ Pervasive use of UAVs is compelling, and the need to ensure that they will perform their designed missions is paramount with large investments being made. Current

flying qualities specifications focus only on ensuring good flying qualities in relation to a human pilot. An example of this is the CAP criterion, whose boundaries are drawn based on the human vestibular system's ability to sense pitch acceleration. This is just one of many examples where the applicability of current flying qualities specifications is suspect, since a pilot is no longer flying the aircraft. Proper flying qualities requirements tailored for UAVs are needed to ensure that UAVs will be able to adequately perform their missions.

2.2.2 Flying Qualities for UAVs

Early attempts at flying qualities specifications provided guidance for basic aircraft of the day.¹³ In 1948 flying qualities research transitioned from its infancy into the modern era of analytical work. During this time frame technology expanded in many fields directly affecting aircraft including propulsion, materials, control systems, and analytical techniques. The speed and altitude capabilities of aircraft saw a significant increase and aircraft configurations began to move in very different directions. These advances coupled with the onset of the Korean War led the U. S. Air Force and Navy to collaborate on the MIL-F-8785 in 1954^{11,17}.

In 1965 Westbrook¹⁷ made a strong case for revisions to flying qualities requirements for aircraft that eventually led to MIL-F-8785C and MIL-STD-1797. Referring to the modern piloted aircraft of the day he stated:

“It becomes very clear that every effort possible in defining the basic criteria, performing complete analyses, and checking the characteristics of the vehicle in the design stage must be made.”

“Very few new aircraft are being procured... When a new vehicle is procured it is expected to be a significant advance over previous aircraft.”

“The contractor is under extreme pressure to meet his schedule and to meet the definitive guarantee of the contract.”

“It is an obvious trend that aircraft have become much more complex. There has been a proliferation of configurations and a spreading of the regimes of flight that the aircraft traverse. There has been a great advance in flight control technology... These trends have several effects on handling qualities criteria. One of the most important is that criteria based only on the dynamics of the vehicle become less and less meaningful from a total system point of view. Another is the widening spread of characteristics, missions, conditions and regimes of flight, automatic and emergency modes of flight, etc. that must be considered and provided for a given vehicle by the criteria.”

“Safety, reliability, and maintainability, have always been of importance to the Air Force. With the immense cost and importance of a single vehicle and the possible loss of life and property of a crash, what would have been considered acceptable attrition in the past can no longer be tolerated. With the great increase in complexity, maintenance costs have zoomed and reliability has dropped. The trend toward a stronger and stronger need for a close tie between these factors and handling qualities criteria will continue.”

Modern UAVs are experiencing growth and evolution similar to manned aircraft during the 1950's. These statements made by Westbrook regarding piloted aircraft are now directly applicable to UAVs. With large investments in UAV technology by the DoD, and expectations of significant reduction in mishap rate, managed advances in UAV technology are expected by the DoD. Government agencies must have a way to judge the performance of new vehicles against a common standard to ensure their effectiveness. With new operational scenarios emerging for UAV use in Iraq and Afghanistan, the pressures on contractors to deliver new capability is increasing. Flying

qualities specifications were created for manned aircraft to aid in their design and assessment. The time has now come to revisit those specifications to create similar standards for UAVs.

One central theme in all the previously mentioned flying qualities documents is that the aircraft's performance and response is tailored to optimize the pilot-aircraft interaction. No guidance is given in these documents for aircraft that are un-piloted. An effort to address unmanned aircraft flying qualities was begun in the 1970's in response to the growing number of remotely piloted vehicles (RPVs).³⁵ While RPV's differ from UAV's in that they are not autonomous, they are similar in that the pilot is removed from the aircraft. This study was a tailoring to remotely piloted vehicles of the eventually accepted MIL-STD-1797 for manned aircraft. While it did not address fully autonomous aircraft, it was a first step toward addressing aircraft performance when a pilot is no longer present in the aircraft. Further work to highlight problems associated with flying qualities and remotely piloted vehicles was presented by Breneman,³⁶ although his work served more to highlight current problems than offer solutions. Small unmanned aircraft present challenges not present in full scale aircraft flight test.^{37,38} For example, current flight testing techniques rely on pilot technique to overcome handling deficiencies in early flight control implementation. Also, small aircraft are not subject to the same aerodynamic effects as large aircraft, since effects that are largely ignored for full scale aircraft become significant for small aircraft. Fundamentally these smaller aircraft respond to disturbances differently than their larger counterparts due to the low Reynolds Number effects that amplify turbulent flow effects and that would be considered insignificant in high Reynolds Number airflow.³⁹ Williams later highlights the need to specify flying qualities criteria.⁴⁰ Current flight testing techniques do not attempt to quantify low Reynolds Number effects. A later attempt to define flying qualities focused on using a dynamic scaling approach to current manned flying qualities criteria, specifically those found in MIL-F-8785C.⁴¹ The criteria neglects, however time delay effects and also only focuses on one type of UAV.

Of all current attempts to define flying qualities for UAVs several issues remain open. One pri-

mary issue is the question of what are flying qualities of an unmanned system?⁴⁰ Second, current attempts have focused purely on mirroring manned specifications to unmanned aircraft, assuming that a UAV must fly like a manned aircraft. Returning to the original purpose of flying qualities specifications, they are “intended to assure flying qualities that provide adequate mission performance and flight safety regardless of design implementation or flight control system mechanization.”⁵ While the word pilot is not directly used, the safety of the pilot is implicit in the definition of flight safety. The safety of the pilot is no longer a required constraint, and the computer controlling the aircraft is not necessarily limited by the same influences that a pilot may be limited. Since the fully augmented UAV no longer has to directly interface with the pilot to achieve its mission objective, the desired mission performance should no longer be linked to criteria that are designed to maximize the pilot’s ability to perform a task. UAV flying qualities should remain focused on achieving the mission performance goals, but without the constraint of human intervention.³⁶ For UAVs the accommodation should be changed from the manned perspective of enabling a pilot to perform a task to enabling a sensor mounted on the aircraft to perform its desired mission. This study aims to leverage current manned criteria in creating new UAV criteria by changing the focus of current manned criteria away from pilot accommodation to sensor/payload accommodation.

Criteria referenced in MIL-STD-1797 may still be applicable for UAVs, with a focus changed from the pilot to the sensor. The LOES approach as well as the pitch bandwidth and Gibson criterion all rely on a simplified dynamic system to model aircraft response to a disturbance.^{27,29,42} Keeping the new requirements in the familiar context of existing flying qualities requirements will also allow easier adoption of the new requirements by those in the aviation community.

Further evidence of the need to define flying qualities for unmanned systems can be found outside of military applications for UAVs. The National Research Council conducted an assessment of NASA’s aeronautics technology programs in 2004. In this review the council found that NASA should increase efforts in research in the area of aircraft flight controls and handling (flying) quali-

ties. Specifically the report states:

“NASA’s past work in flight controls and handling qualities provided the reference standard for today’s system designs. However, as we move toward unmanned systems, the existing standards, which are for manned systems, may be too restrictive. Further evolution of the base work done by NASA to include unmanned systems is essential to creating a competitive advantage for US products as this market becomes more price-driven.”⁴³

NASA’s aeronautics research interest has traditionally complemented the US military’s interests. While NASA has done research in areas that have direct military application (such as its long history in X-plane research,⁴⁴ as well as such programs as the High Alpha Research Vehicle (HARV)⁴⁵), it has also done research for civilian benefit as well.³⁴

2.2.3 Current Work in UAV Flying Qualities

Flying qualities and airworthiness criteria in use today measure an aircraft’s flying qualities based on the prediction of an average pilot’s ability to perform a given task with an aircraft. Since there is no pilot on board to fly the UAV, a central theme in flying qualities determination for airworthiness is no longer present. The pilot’s role has been replaced by a flight control system performing a prescribed maneuver. While the mission of the UAV may be similar to that of a manned aircraft, the critical link to a successful mission is no longer the pilot’s ability to fly the aircraft. The critical link is now the payload’s ability to perform its task while integrated with the UAV. UAVs therefore require a new set of criteria to describe their performance in relation to their payload and designed mission.

To date work done to tailor flying qualities for UAVs has been focused on remotely piloted vehicles (RPVs). In 1976 Rockwell International compiled applicable sections of MIL-8785B, MIL-F-83300, MIL-F-9490D, and MIL-C-18244A into a new design guidance document for use with RPVs.³⁵ Specific tailoring of requirements to UAVs was not done in this study; the work was done

specifically for RPVs without mention of autonomously operating UAVs. The Naval Air Warfare Center published results from applying and then testing modified manned flying qualities criteria to small scale RPVs.³⁶ Work has also been done to show that short period natural frequency requirements should be different for small UAVs compared to traditional aircraft.^{41,46} Using dynamic scaling, both reports suggested different natural frequency boundaries for small UAVs versus full scale piloted aircraft.

Dynamic scaling^{47,48} defines a relationship between a full scale vehicle and a small scale model. Scaling can be performed on a wide variety of parameters⁴⁹ affecting dynamic response including natural frequency (ω_n), time constant (τ) and moments of inertia (I) based on a scale factor $N \geq 1$.

$$\omega_{n_{\text{model}}} = \sqrt{N} \omega_{n_{\text{fullscale}}}$$

$$\tau_{\text{model}} = \sqrt{N} \tau_{\text{fullscale}}$$

$$I_{\text{model}} = \frac{1}{N^5} I_{\text{fullscale}}$$

This method has shown success when comparing a sub-scale model to a full-scale vehicle using remotely piloted control.⁴⁸ These RPV frequency techniques on dynamic scaling require a full scale vehicle to determine an appropriate scaling factor. Representative large scale vehicles for different UAV classes must be identified if these techniques are to be applicable to all RPVs.

2.3 Nonlinear Control Flying Qualities

Aircraft cannot be modeled throughout their entire flight envelope as linear differential equations due to nonlinear affects. Linear control theory has been used, however, as the defacto-standard of aircraft control systems. Linear models of aircraft are created to at discrete flight conditions throughout an aircraft's flight envelope. These flight conditions are then patched together to create a piece-

wise continuous linear aircraft model used for analysis as well as control design. Linear methods give insight to control synthesis that can be difficult to obtain with nonlinear control systems.^{10,50} As sophistication of aircraft increased, and the demands on basic linear control theory advanced, the application of modern control theory began to become more preeminent in aircraft,^{51,52} but it still can not account for uncertainties such as control surface failure or reconfiguration. To account for aircraft control system failures, a piecewise control system approach has been applied to full scale aircraft,⁵³ but can be time intensive, and can not guarantee full flight envelope coverage. With the relatively recent application of nonlinear control theory to aircraft, new possibilities for control robustness can be explored. Full control surface failure or outer mold line morphing / change can be accounted for within the control system, so long as the physical system can generate the required moments to overcome disturbances.⁵⁴ The exciting increase of capability has brought with it a new set of problems associated with human interface with vehicles with nonlinear, adaptive control. Early testing of adaptive control has occurred to date with piloted vehicles.⁵⁵⁻⁵⁸ While these adaptive methods can account for large uncertainties, their validation for use in piloted aircraft is still untested. Significant issues relating to the human interface to these control systems still remain.⁵⁹

Adaptive control algorithms have given hope to a new level of flight vehicle robustness previously unachievable with traditional control methods. Recent Air Force programs RESTORE (X-36) and JDAM have demonstrated the potential of adaptive controllers for compensation of modeling uncertainties and component failures. However, the major lesson learned during those programs was that the conventional model reference adaptive control scheme is very sensitive to time-delay, especially if the controller attempts to adapt quickly.⁶⁰ This has consequently led to a new paradigm for design of adaptive controllers, specifically The Theory of Fast and Robust Adaptation.⁶¹⁻⁶⁸ The Theory of Fast and Robust Adaptation provides an ability for a priori prediction of the uniform performance bounds –for transient and steady-state – for a system’s input and output signals, and also analytical quantification of the gain and time-delay margin, similar to linear systems’ gain and phase margin concepts. Various architectures of this theory, known as \mathcal{L}_1 adaptive controllers, have been flight

tested and validated against the theoretical claims.^{69–77} While it may be proven that an aircraft can be stabilized when in a degraded or unknown state, the flying qualities of the flight vehicle must be favorable if a piloted system is to be controlled, especially during critical phases such as landing or formation flight, e.g. air to air refueling.

2.4 Teaching Flight Mechanics

Teaching students in an Aerospace Engineering curriculum presents challenges that are not usually present in traditional engineering programs. Because of the size, cost, and liability associated with operating full scale aircraft, most aerospace engineering students only encounter pictures of aircraft in a classroom. While scientific knowledge and theoretical concepts can be clearly communicated in a traditional classroom, practical experience with aircraft is generally infeasible. This is especially problematic in the teaching of atmospheric flight mechanics and flying qualities, since these disciplines study the integration of the entire aircraft and how it responds to pilot or operator commands. Modern use of remote control aircraft in the aerospace curriculum aids students by giving them some practical experience, but it only gives students an experience by proxy, and not the immersive experience that flight in an aircraft brings. This creates a barrier to learning for students eager to fully understand aerospace engineering concepts with no way to practice the concepts they have learned outside of traditional homework problems and tests. The result is that an aerospace engineering curriculum attracts students with great mathematical prowess and often excludes students with more practically based engineering skills. Education in engineering requires a balance of scientific knowledge and practical experience to cultivate well rounded engineers.

The National Academy of Engineering (NAE) challenges educators in *Educating the Engineer of 2020* to pursue student oriented education. They encourage :

1. better alignment of engineering curricula and the nature of academic experiences with the challenges and opportunities graduates will face in the workplace and

2. better alignment of faculty skill sets with those needed to deliver the desired curriculum in light of the different learning styles of students.⁷⁸

The NAE also highlights a growing separation between practicing engineers and engineering faculty. The NAE states

“The great majority of engineering faculty, for example have no industry experience. Industry representatives point to this disconnect as the reason that engineering students are not adequately prepared, in their view, to enter today’s workforce.”⁷⁸

The National Research Council proposes in *How People Learn* that technology can be used to support learning by “bringing exciting curricula based on real-world problems into the classroom” and “building local and global communities that include teachers, administrators, students, parents, practicing scientists, . . .”⁷⁹ By using a Learner-Centered approach,⁸⁰ and Problem Based Learning (PBL)^{81,82} as a baseline pedagogy, the authors have been able to use available technology to create a curriculum that directly answers the challenge offered by the NAE.

Aerospace engineering education needs to attract creative students that are more than just math whizzes. Students are attracted to engineering because of other reasons besides liking math. Employers need students that understand airplanes conceptually as well as theoretically. Students that just understand basic equations are not effective in advancing a complex system such as an aircraft where the integration of disciplines is key to a successful design. Engineering education has swung from being overly practical to in some cases overly theoretical where students are not engaged in the hands on practice of engineering. The balance needs to be realigned. This can be done by using problem based learning and connecting students and teachers with industry experts in order to assure classroom assignments and example problems are relevant and “real.”

Traditional design classes taught at the senior level serve as capstone courses to most curriculums. These design classes offer a chance for students to see the different courses they have taken

integrated together, but they rarely allow students a chance at experiential knowledge. Often these classes turn into another analysis course that is nothing more than a revisiting of the courses they have taken before. The medical communities have found significant reductions in student errors after participating in simulations.^{83,84} Students using this method get a chance to practice their skills before being exposed to real patients where serious harm can be done by making mistakes that could be avoided with simple experience with their newly learned skills. Just as the engineering educational community has been influenced through medical education with Problem Based Learning^{81,82} learning through simulated immersion is another tool that engineering educators can take and apply from the medical educational field. Before entering the workforce students must have first hand exposure to more than just analytical skills. Students must apply their knowledge to learn by doing. This type of simulated immersion extends beyond the goals of a typical design class where the goal is to submit an analytical paper. Students need to have a means to work on something that gives them an output for their input. The output should not be easily gamed or manipulated by the students to produce an inaccurate response to the inputs. These immersive, simulated learning environments lend motivation and credence to the theoretical material they learn in analytical classroom settings.⁸⁵

Aircraft Equations of Motion

THE analytical work done for this research has at its foundation the assumption that the aircraft analyzed are rigid bodies. In the most general case a rigid body moving freely through space can be defined by six coordinates, three in translation, and three in rotation.⁸⁶ Using this assumption six degrees of freedom (6 DOF) nonlinear differential equations have traditionally been used to model aircraft rigid body motion for analysis. Derivations of the exact equations used can take many different forms of varying complexity depending on the assumptions used in their derivation. They have been derived in different forms in various texts, and can be readily found in Perkins and Hague,⁸⁷ McGruer et al.,⁸⁸ Stevens and Lewis,⁸⁹ and Etkin¹ as well as many others. For a historical overview of the development of the aircraft equations of motion McGruer gives detail to not only the equation development, but the sources where the original concepts were derived. These equations have been developed in many forms for various uses, and they will be derived here for use in near Earth flight. There will be four assumptions made in deriving the nonlinear equations of motion for aircraft flight.

Assumption 3.1: The airframe is a rigid body.

Assumption 3.2: The Earth is flat, and fixed in space.

Assumption 3.3: The mass and its distribution in the vehicle are constant.

Assumption 3.4: The X-Z plane in the vehicle is symmetric.

Using assumption 3.1 the degrees of freedom of the body can be limited to six degrees of freedom, whose position in space can be described in translation and rotation about its center of mass. From assumption 3.2 an inertial coordinate frame relative to the Earth can be established for relatively short flight times and distances. Once an inertial reference frame is established, Newton's second law can be applied. Linear momentum is defined as $\mathbf{p} = m\mathbf{V}_i$, and the time rate of change of linear momentum is equal to the sum of all externally applied forces.

$$\frac{d\mathbf{p}}{dt} = \sum \mathbf{F} \quad (3.1)$$

The rate of change of angular momentum is equal to the sum of all externally applied torques.

$$\frac{d\mathbf{H}}{dt} = \sum \mathbf{M} \quad (3.2)$$

The time rate of change of momentum can be described as

$$\frac{d\mathbf{p}}{dt} = m \frac{d\mathbf{V}_i}{dt} - \mathbf{V}_{ex} \frac{dm}{dt} = \mathbf{F} \quad (3.3)$$

or rearranged as

$$m \frac{d\mathbf{V}_i}{dt} = \mathbf{F} + \mathbf{V}_{ex} \frac{dm}{dt} = \mathbf{F} + \mathbf{T}. \quad (3.4)$$

\mathbf{T} is defined as $\mathbf{V}_{ex} \frac{dm}{dt}$ and is the thrust component due to expulsion of vehicle mass. Equation (3.1) can be used for vehicles that do not use vehicle mass for momentum exchange, and Equation (3.4) can be used for vehicles where vehicle mass is used for momentum exchange, such as rockets. For conventional aircraft, the thrust term \mathbf{T} can be contained within the external forces \mathbf{F} . Inertial space can be represented as a right hand Cartesian coordinate frame $\langle \mathcal{X}, \mathcal{Y}, \mathcal{Z} \rangle$ and the velocity vector $\mathbf{V}_i = \langle \mathcal{U}, \mathcal{V}, \mathcal{W} \rangle$, and a total force $\mathbf{F} = \langle F_{\mathcal{X}}, F_{\mathcal{Y}}, F_{\mathcal{Z}} \rangle$. Equation (3.4) can

be rewritten as

$$m \frac{d\mathcal{U}}{dt} = F_x \quad (3.5)$$

$$m \frac{d\mathcal{V}}{dt} = F_y \quad (3.6)$$

$$m \frac{d\mathcal{W}}{dt} = F_z \quad (3.7)$$

The rotary equations can be further defined by the definition of angular momentum

$$\mathbf{H} = [\mathbf{I}] \cdot \boldsymbol{\Omega} \quad (3.8)$$

where $[\mathbf{I}]$ is the inertia matrix and $\boldsymbol{\Omega}$ is the angular velocity. The time derivative can then be defined as

$$\frac{d\mathbf{H}}{dt} = [\mathbf{I}] \cdot \frac{d\boldsymbol{\Omega}}{dt} + \frac{d[\mathbf{I}]}{dt} \cdot \boldsymbol{\Omega} = \mathbf{M}. \quad (3.9)$$

In order to simplify Equation (3.9) a body fixed coordinate frame can be established as can be seen in Figure 3.1.

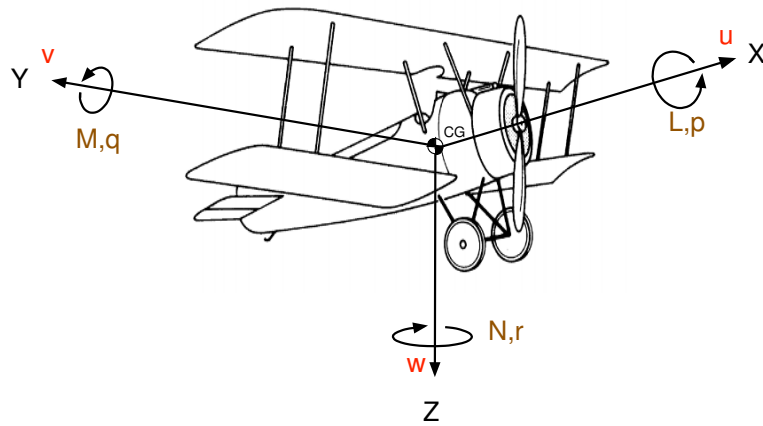

Figure 3.1: Body axis fixed coordinate system.

Using a body fixed coordinate frame where the vehicle's mass is assumed constant allows the time rate of change of inertia to be defined as $\frac{d[\mathbf{I}]}{dt} = 0$, simplifying the analysis of the vehicle equations of motion. In order to determine the rectilinear acceleration of the vehicle in body coordinates, both linear and rotational velocities must be considered. Using the theorem of Coriolis:

$$\mathbf{a} = \frac{d\mathbf{V}_b}{dt} = \dot{\mathbf{V}}_b + \boldsymbol{\Omega}_b \times \mathbf{V}_b. \quad (3.10)$$

the linear and rotational velocities in the body frame can be used to find the acceleration of the vehicle with respect to an inertially fixed frame. Taking

$$\mathbf{V}_b = u\hat{\mathbf{i}} + v\hat{\mathbf{j}} + w\hat{\mathbf{k}} \quad (3.11)$$

$$\boldsymbol{\Omega} = p\hat{\mathbf{i}} + q\hat{\mathbf{j}} + r\hat{\mathbf{k}} \quad (3.12)$$

$$(3.13)$$

the rectilinear acceleration terms can be defined as:

$$a_x = \dot{u} + qw - rv \quad (3.14)$$

$$a_y = \dot{v} + ru - pw \quad (3.15)$$

$$a_z = \dot{w} + pv - qu \quad (3.16)$$

In a similar manner to Equation (3.4), the time rate of change in angular momentum can be defined as

$$\frac{d\mathbf{H}}{dt} = \dot{\mathbf{H}} + \boldsymbol{\Omega} \times \mathbf{H} \quad (3.17)$$

where

$$\mathbf{H} = [\mathbf{I}] \cdot \boldsymbol{\Omega}. \quad (3.18)$$

Expanding \mathbf{H} yields

$$\mathbf{H} = [pI_{xx} - qI_{xy} - rI_{xz}] \hat{\mathbf{i}} + [-pI_{xy} + qI_{yy} - rI_{yz}] \hat{\mathbf{j}} + [-pI_{xz} - qI_{yz} + rI_{zz}] \hat{\mathbf{k}}. \quad (3.19)$$

Using assumption 3.4 that there is a plane of symmetry in the X-Z plane as seen in Figure 3.2

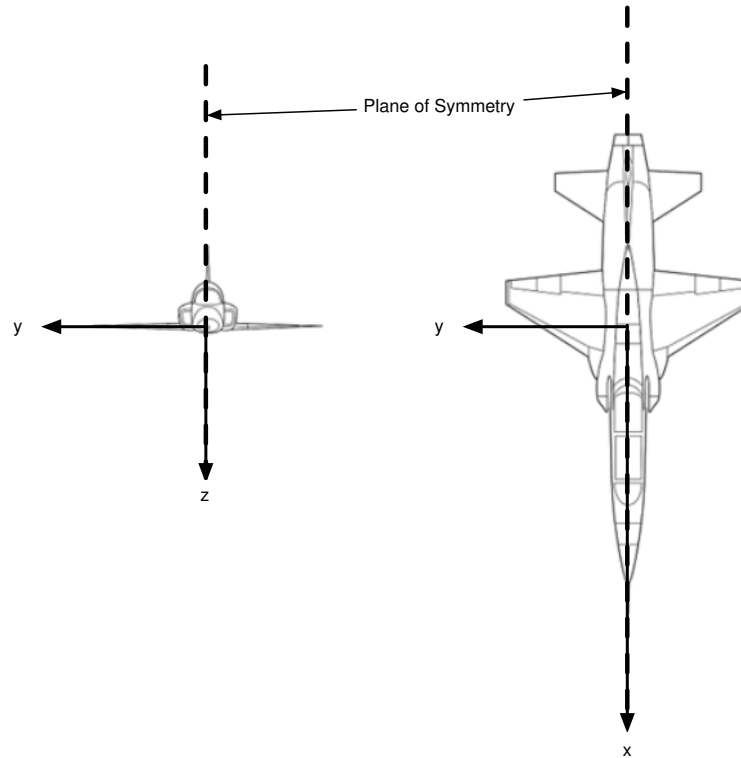

Figure 3.2: Aircraft symmetry in the X-Z plane.

further simplification can be achieved. This assumption allows the right and left hand sides of the aircraft to be considered mirror images of each other. Taking advantage of this assumption gives $I_{yz} = I_{xy} = 0$. The full set of expanded equations of motion for an aircraft referenced to a body-

fixed axis can then be written as:

$$\sum F_X = m(\dot{u} + qw - rv) \quad (3.20)$$

$$\sum F_Y = m(\dot{v} + ru - pw) \quad (3.21)$$

$$\sum F_Z = m(\dot{w} + pv - qu) \quad (3.22)$$

$$\sum L = \dot{p}I_{xx} - \dot{r}I_{xz} + qr(I_{zz} - I_{yy}) - pqI_{xz} \quad (3.23)$$

$$\sum M = \dot{q}I_{yy} + pr(I_{xx} - I_{zz}) - r^2I_{xz} + p^2I_{xz} \quad (3.24)$$

$$\sum N = \dot{r}I_{zz} - \dot{p}I_{xz} + pq(I_{yy} - I_{xx}) + qrI_{xz} \quad (3.25)$$

Relating the rotation of the body fixed frame to the inertially fixed earth frame requires the use of rotation matrices to create a direction cosines matrix. Standard convention for aircraft uses a 3-2-1 rotation system defined as:

1. A right-handed rotation about the inertial Z -axis (positive ψ)
2. A right-handed rotation about the new y -axis (positive θ)
3. A right-handed rotation about the new x -axis (positive ϕ), which is also the body roll axis.

This creates a transformation between body axis and earth fixed inertial defined as:

$$\begin{bmatrix} x \\ y \\ z \end{bmatrix}_{body} = \begin{bmatrix} 1 & 0 & 0 \\ 0 & \cos \phi & \sin \phi \\ 0 & -\sin \phi & \cos \phi \end{bmatrix} \begin{bmatrix} \cos \theta & 0 & -\sin \theta \\ 0 & 1 & 0 \\ \sin \theta & 0 & \cos \theta \end{bmatrix} \begin{bmatrix} \cos \psi & \sin \psi & 0 \\ -\sin \psi & \cos \psi & 0 \\ 0 & 0 & 1 \end{bmatrix} \begin{bmatrix} x \\ y \\ z \end{bmatrix}_{earth} \quad (3.26)$$

This rotation defines the relationship between the orientation of the earth fixed coordinate frame and the body fixed coordinate frame with the three Euler angles (θ, ϕ, ψ) . Using this relationship a

further relationship between body angle rates and the Euler angles rates can be defined as

$$\begin{bmatrix} p \\ q \\ r \end{bmatrix} = \begin{bmatrix} 1 & 0 & -\sin \theta \\ 0 & \cos \phi & \cos \theta \sin \phi \\ 0 & -\sin \phi & \cos \theta \cos \phi \end{bmatrix} \begin{bmatrix} \dot{\phi} \\ \dot{\theta} \\ \dot{\psi} \end{bmatrix} \quad (3.27)$$

Remembering assumptions 3.1 - 3.3, and assuming flight close to the Earth the force of gravity can be considered constant as applied to the aircraft. Gravity is considered to act normal to the local horizontal plane in the Earth fixed coordinate frame. The gravity vector can therefore be projected into the aircraft body axis coordinate frame using the predefined Euler angles (θ, ϕ, ψ) as seen in Figure 3.3. The Earth relative gravity vector has a non-zero component in the \hat{z} direction. Using Equation (3.26) to transform earth fixed coordinates to body fixed coordinates,

$$(F_x)_{\text{gravity}} = -mg \sin \theta \quad (3.28)$$

$$(F_y)_{\text{gravity}} = -mg \cos \theta \sin \phi \quad (3.29)$$

$$(F_z)_{\text{gravity}} = -mg \cos \theta \cos \phi. \quad (3.30)$$

The force of gravity can therefore be added to the equations of motion to yield:

$$\sum F_X = m(\dot{u} + qw - rv + g \sin \theta) = ma_x \quad (3.31)$$

$$\sum F_Y = m(\dot{v} + ru - pw - g \cos \theta \sin \phi) = ma_y \quad (3.32)$$

$$\sum F_Z = m(\dot{w} + pv - qu - g \cos \theta \cos \phi) = ma_z \quad (3.33)$$

$$\sum L = \dot{p}I_{xx} - \dot{r}I_{xz} + qr(I_z - I_y) - pqI_{xz} \quad (3.34)$$

$$\sum M = \dot{q}I_{yy} + pr(I_{xx} - I_{zz}) - r^2I_{xz} + p^2I_{xz} \quad (3.35)$$

$$\sum N = \dot{r}I_{zz} - \dot{p}I_{xz} + pq(I_{yy} - I_{xx}) + qrI_{xz} \quad (3.36)$$

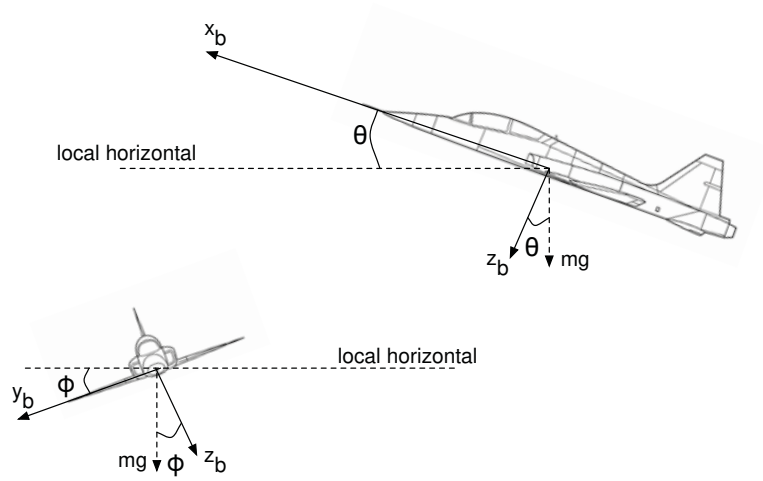

Figure 3.3: Gravity vector in relation to aircraft body coordinates.

These equations can be rearranged and solved in terms of their state derivatives.⁸⁹ Using the form found in Stevens and Lewis,⁸⁹ they form four sets of equations commonly referred to as :

Force Equations

$$\dot{u} = rv - qw - g \sin \theta + \frac{F_x}{m} \quad (3.37)$$

$$\dot{v} = ru - pw + g \sin \phi \cos \theta + \frac{F_y}{m} \quad (3.38)$$

$$\dot{w} = qu - pv + g \cos \phi \cos \theta + \frac{F_z}{m} \quad (3.39)$$

Kinematic Equations

$$\dot{\phi} = p + \tan \theta (q \sin \phi + r \cos \phi) \quad (3.40)$$

$$\dot{\theta} = q \cos \phi - r \sin \phi \quad (3.41)$$

$$\dot{\psi} = \frac{q \sin \phi + r \cos \phi}{\cos \theta} \quad (3.42)$$

Moment Equations

$$\dot{p} = (c_1 r + c_2) q + c_3 L + c_4 N \quad (3.43)$$

$$\dot{q} = c_5 p r - c_6 (p^2 - r^2) + c_7 M \quad (3.44)$$

$$\dot{r} = (c_8 p - c_2 r) Q + c_4 L + c_9 N \quad (3.45)$$

Navigation Equations

$$\begin{aligned} \dot{p}_N &= u \cos \theta \cos \psi + v(-\cos \phi \sin \psi + \sin \phi \sin \theta \cos \phi) \\ &\quad + w(\sin \phi \sin \psi + \cos \phi \sin \theta \cos \phi) \end{aligned} \quad (3.46)$$

$$\begin{aligned} \dot{p}_E &= u \cos \theta \sin \psi + v(\cos \phi \cos \psi + \sin \phi \sin \theta \sin \psi) \\ &\quad + w(-\sin \phi \cos \psi + \cos \phi \sin \theta \sin \psi) \end{aligned} \quad (3.47)$$

$$\dot{h} = u \sin \theta - v \sin \phi \cos \theta - w \cos \phi \cos \theta \quad (3.48)$$

where $c_1 - c_9$ are defined^{89,90} as

$$c_1 = \frac{(I_{yy} - I_{zz})I_{zz} - I_{xz}^2}{\Gamma} \quad (3.49)$$

$$c_2 = \frac{(I_{xx} - I_{yy} + I_{zz})I_{xz}}{\Gamma} \quad (3.50)$$

$$c_3 = \frac{I_{zz}}{\Gamma} \quad (3.51)$$

$$c_4 = \frac{I_{xz}}{\Gamma} \quad (3.52)$$

$$c_5 = \frac{I_{zz} - I_{xx}}{I_{yy}} \quad (3.53)$$

$$c_6 = \frac{I_{xz}}{I_{yy}} \quad (3.54)$$

$$c_7 = \frac{1}{I_{yy}} \quad (3.55)$$

$$c_8 = \frac{I_{xx}(I_{xx} - I_{yy}) + I_{xz}^2}{\Gamma} \quad (3.56)$$

$$c_9 = \frac{I_{xx}}{\Gamma} \quad (3.57)$$

$$\Gamma = I_{xx}I_{zz} - I_{xz}^2 \quad (3.58)$$

Often the states u, v, w are replaced with total velocity V_t , and angle of attack α and angle of sideslip β as defined in Figure 3.4. When u, v, w are replaced, they can be calculated using

$$\begin{bmatrix} u \\ v \\ w \end{bmatrix} = \begin{bmatrix} V_t \cos \alpha \cos \beta \\ V_t \sin \beta \\ V_t \sin \alpha \cos \beta \end{bmatrix} \quad (3.59)$$

and the new states are defined as

$$\dot{V}_t = \frac{u\dot{u} + v\dot{v} + w\dot{w}}{V_t} \quad (3.60)$$

$$\dot{\alpha} = \frac{u\dot{w} - w\dot{u}}{u^2 + w^2} \quad (3.61)$$

$$\dot{\beta} = \frac{v\dot{V}_t - V_t\dot{v}}{V_t^2 \cos \beta} \quad (3.62)$$

The solution to Equation (3.37) - Equation (3.48) or their wind derived equations in Equation (3.60) - Equation (3.62) is done numerically using a numerical integrator.

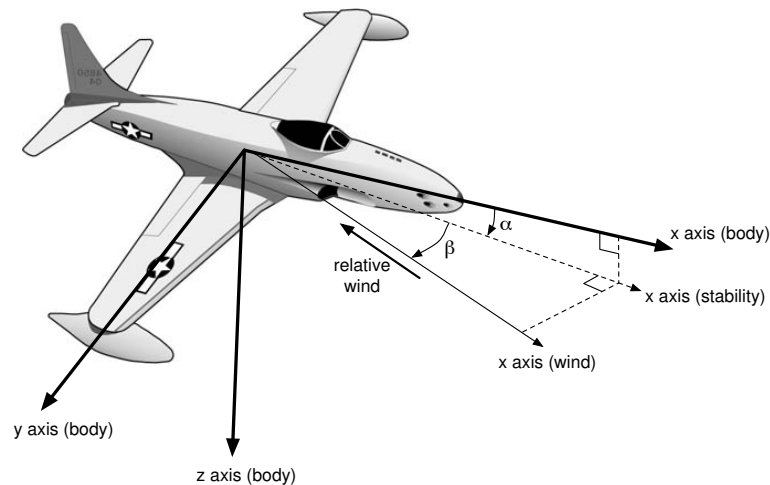

Figure 3.4: Angle of attack and angle of sideslip in relation to aircraft body coordinates.

The primary forces acting on an aircraft beside gravity are lift and drag, and when nondimensionalized their variation can be considered linear in small regions used for vehicle study. The lift and drag force, which do not always act at the center of gravity, act to impart forces and moments in all axes of the aircraft. Control surface movements (such as elevators, ailerons, and rudders) also impart forces and moments as well as the engine(s), and any stabilizing surfaces, such as the horizontal or vertical tail, wings and fuselage. Their effects are quantified in an aircraft's stability derivatives. The standard convention used in control surface deflection is shown in Figure 3.5.

Using the linear variation of the forces and moments over small regions of flight, another approach in analyzing the equations of motion is often used instead of solving them directly. This approach requires the equations to be simplified into a linear form. Traditionally the linearized equations have been used in order to gain insight into the different aircraft modes of motion. The linearization process for aircraft equations of motion has been well documented in many sources,^{1,88,89} and a more generalized process for linearizing nonlinear equation of motion can be found in many texts as well.^{86,91} By first picking a trim point where all the vehicle states are constant (not necessarily zero), a set of linearized equations can be formed by either analytical or numerical techniques. For the work presented in this document analytical techniques were used to create the linear equations of motion. A Taylor's series expansion⁹² about a steady state (trim) condition for each state can be accomplished where only the first order terms of the Taylor's series expansion are kept. This expansion forms the linear equations of motion for an aircraft.

If an assumption is made that steady horizontal flight is present ($\gamma_0 = 0$) then the linearized, longitudinal aircraft equations of motion referenced to the stability axis in frequency domain can be

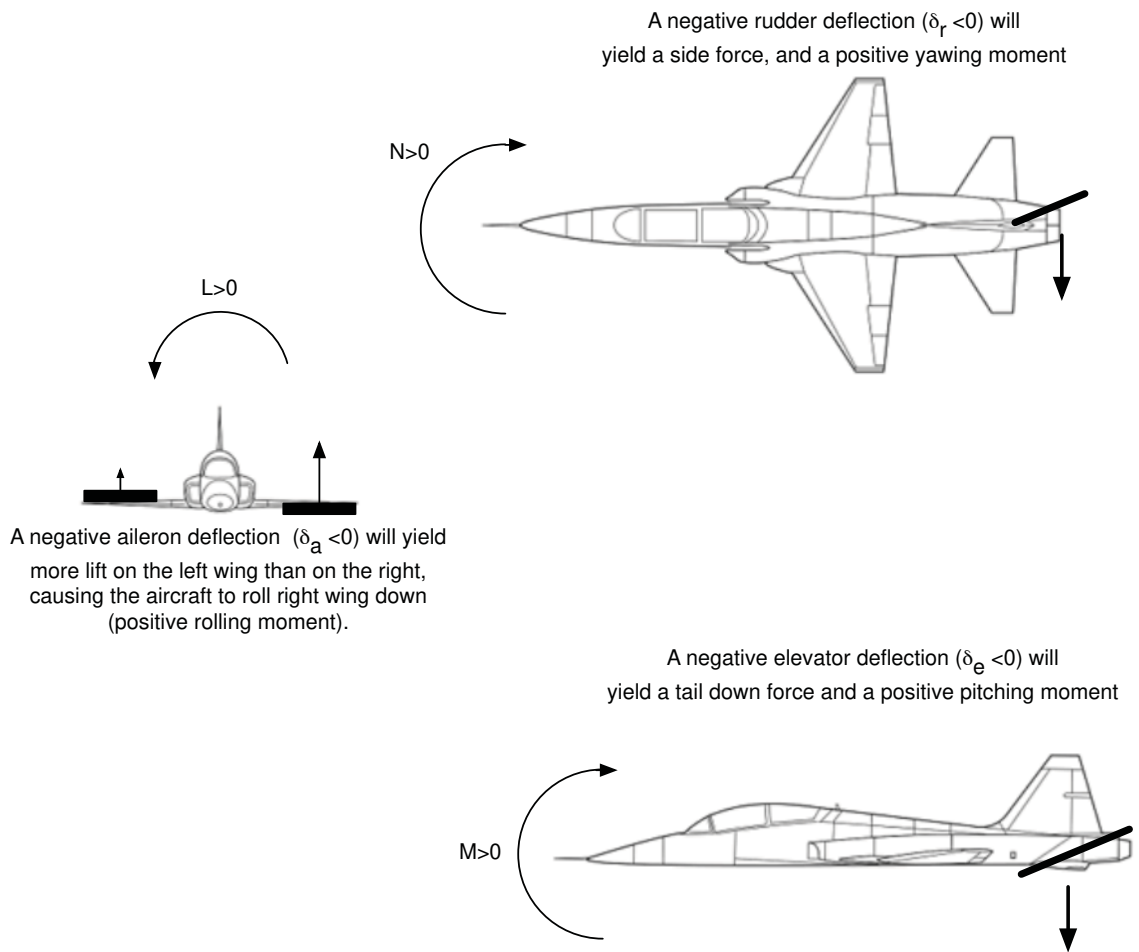

Figure 3.5: Typical sign conventions for aircraft control surface deflections.

simplified to:⁸⁸

$$(s - x_u)u - x_w w + g\theta = x_\delta \delta - x_u u_g - x_w w_g \quad (3.63)$$

$$-z_u u + (s - z_w)w - u_0 s \theta = z_\delta \delta - z_u u_g - z_w w_g \quad (3.64)$$

$$\begin{aligned} -m_u u - (m_{\dot{w}} s + m_w)w + s(s - m_q)\theta &= m_\delta \delta - m_u u_g \\ &\quad - [(m_{\dot{w}} - m_q/u_0)s + m_w]w_g \end{aligned} \quad (3.65)$$

$$s\theta = q \quad (3.66)$$

$$a_z = \dot{w} - u_0 s \theta = -h \quad (3.67)$$

Transfer functions can be generated from the linear longitudinal equations by solving the equations for the desired variable, with all the input variables except for the desired input set to zero. As an example Kramer's rule can be used to determine transfer functions.

$$\frac{w(s)}{\delta(s)} = \frac{\begin{vmatrix} s - X_u & X_\delta & g \\ -Z_u & Z_\delta & U_0 s \\ -M_u & M_\delta & s(s - M_q) \end{vmatrix}}{\begin{vmatrix} S - X_u & -X_w & g \\ -Z_u & s - Z_w & U_0 s \\ -M_u & -(M_{\dot{w}} s + M_w) & s(s - M_q) \end{vmatrix}} \quad (3.68)$$

These transfer functions as derived in McRuer et al.⁸⁸ can then be defined as:

$$\frac{\theta(s)}{\delta(s)} = \frac{A_\theta s^2 + B_\theta s + C_\theta}{\Delta_{long}} = \frac{A_\theta(s + 1/T_{\theta_1})(s + 1/T_{\theta_2})}{\Delta_{long}} \quad (3.69)$$

$$\frac{w(s)}{\delta(s)} = \frac{A_w s^3 + B_w s^2 + C_w s + D_w}{\Delta_{long}} = \frac{A_w(s + 1/T_{w_1})(s + 1/T_{w_2})(s + 1/T_{w_3})}{\Delta_{long}} \quad (3.70)$$

$$\frac{u(s)}{\delta(s)} = \frac{A_u s^3 + B_u s^2 + C_u s + D_u}{\Delta_{long}} = \frac{A_u(s + 1/T_{u_1})(s + 1/T_{u_2})(s + 1/T_{u_3})}{\Delta_{long}} \quad (3.71)$$

$$\frac{h(s)}{\delta(s)} = \frac{A_h s^3 + B_h s^2 + C_h s + D_h}{\Delta_{long}} = \frac{A_h(s + 1/T_{h_1})(s + 1/T_{h_2})(s + 1/T_{h_3})}{\Delta_{long}} \quad (3.72)$$

$$\frac{a_z(s)}{\delta(s)} = -s^2 \frac{h(s)}{\delta(s)} \quad (3.73)$$

$$\Delta_{long} = As^4 + Bs^3 + Cs^2 + Ds + E = (s^2 + 2\zeta_p\omega_p s + \omega_p^2)(s^2 + 2\zeta_{sp}\omega_{sp} s + \omega_{sp}^2) \quad (3.74)$$

Equation (3.74) is the characteristic polynomial for the aircraft longitudinal motion. The equation is fourth order, and represents two second order modes of motion. These modes are defined as the short period and phugoid modes. The natural frequency and damping ratio for the short period can be shown⁸⁹ to be :

$$\omega_{n_{sp}} = \left(\frac{M_q}{Z_\alpha} V_T - M_\alpha \right)^{\frac{1}{2}} \quad (3.75)$$

$$\zeta_{sp} = \frac{-(M_q + M_{\dot{\alpha}} + Z_\alpha/V_T)}{2\omega_{n_{sp}}} \quad (3.76)$$

Only the longitudinal equations of motion are used for the work in this dissertation. The corresponding lateral-directional linearized equations can be found in McRuer et al.⁸⁸

	A	B	C	D
θ	$M_\delta + Z_\delta M_{\dot{w}}$	$X_\delta(Z_u M_{\dot{w}} + M_u)$ $+ Z_\delta(M_w X_w - M_{\dot{w}})$ $- M_\delta(X_u + Z_w)$	$X_\delta(Z_u M_w - Z_w M_u)$ $+ Z_\delta(M_u X_w - M_w X_u)$ $+ M_\delta Z_w X_u - X_w Z_u$	
w	Z_δ	$X_\delta Z_u - Z_\delta(X_u + M_q)$ $+ M_\delta U_0$	$X_\delta(U_0 M_u - Z_u M_q)$ $+ Z_\delta X_u M_q - U_0 M_\delta X_u$	$g(Z_\delta M_u - M_\delta Z_u)$
u	X_δ	$-X_\delta(Z_w + M_q + M_{\dot{\alpha}})$ $+ Z_\delta X_w$	$X_\delta(Z_w M_q - M_\alpha)$ $- Z_\delta(X_w M_q + g M_{\dot{w}})$ $+ M_\delta(X_\alpha - g)$	$g(M_\delta Z_w - Z_\delta M_w)$
h	$-Z_\delta$	$-X_\delta Z_u$ $+ Z_\delta(M_q + M_{\dot{\alpha}} + X_u)$	$M_\delta Z_u(M_q + M_{\dot{\alpha}})$ $- Z_\delta[X_u(M_q + M_{\dot{\alpha}} - M_\alpha)]$ $- M_\delta Z_\alpha$	$-X_\delta(Z_\alpha M_u - M_\alpha Z_u)$ $+ Z_\delta[M_u(X_\alpha - g) - M_\alpha X_u]$ $+ M_\delta[Z_\alpha X_u - Z_u(X_\alpha - g)]$
Δ	1	$-M_q - M_{\dot{\alpha}} - Z_w - X_u$	$Z_w M_q - M_\alpha - X_w Z_u$ $+ X_u(M_q + M_{\dot{\alpha}} + Z_w)$	$-X_u(Z_w M_q - M_\alpha)$ $+ Z_u(X_w M_q + g M_{\dot{w}})$ $- M_u(X_\alpha - g)$
			$E = g(Z_u M_w - M_u Z_w)$	

Table 3.1: Variable definitions for transfer functions found in Equation (3.69) - Equation (3.73).

Review of Linear Systems

LINEAR systems are often used to model more complex dynamical systems. While their application is limited typically to a small range of the full system's domain, linear systems can be used to approximate a dynamical system and greatly reduce the complexity of the analysis of the system. This analysis employs the use of a homogeneous linear system of differential equations, where the principle of superposition applies. The most general form of these systems can be taken to be:

$$\dot{x}_j = \sum_{i=1}^n A_{ji}(t)x_i \quad j = 1, 2, \dots, n$$

4.1 Transfer Functions

A transfer function is a method used to map a system's inputs to its outputs. Transfer functions can be represented both in mathematical and graphical forms. An example of a graphical form of a transfer function can be seen in Figure 4.1.

Mathematically, assume a system can be described as a linear differential equation



Figure 4.1: Basic block diagram example

$$\begin{aligned} & \left(\frac{d^m}{dt^m} + b_1 \frac{d^{m-1}}{dt^{m-1}} + \cdots + b_{m-1} \frac{d}{dt} + b_m \right) y(t) \\ &= \kappa \left(\frac{d^n}{dt^n} + a_1 \frac{d^{n-1}}{dt^{n-1}} + \cdots + a_{n-1} \frac{d}{dt} + a_n \right) x(t) \end{aligned} \quad (4.1)$$

where $m > n$. To analyze a function of this kind, the Laplace transform can be applied in order to analyze the system in a frequency domain. The Laplace transform can be defined as

$$\mathcal{L}[f(t)] = F(s) = \int_0^{\infty} f(t)e^{st} dt \quad (4.2)$$

where s is a complex variable defined by $s = \sigma + j\omega$. Applying the Laplace transform as defined in Equation (4.2) to the system defined in Equation (4.1) the differential equation can be transformed to the algebraic equation

$$\begin{aligned} & (s^m + b_1 s^{m-1} + \cdots + b_{m-1} s + b_m) Y(s) \\ &= \kappa (s^n + a_1 s^{n-1} + \cdots + a_{n-1} s + a_n) X(s). \end{aligned} \quad (4.3)$$

Rearranging Equation (4.3) a transfer function can be found where

$$U(s) = \kappa \frac{(s^n + a_1 s^{n-1} + \cdots + a_{n-1} s + a_n)}{(s^m b_1 s^{m-1} + \cdots + b_{m-1} s + b_m)} \quad (4.4)$$

and $Y(s)$ is described as

$$Y(s) = U(s)X(s) \quad (4.5)$$

and the time domain solution can be found by taking

$$y(t) = \mathcal{L}^{-1}[Y(s)]. \quad (4.6)$$

For a simple, second order system setting $x(t) = \delta(t)$ so that $X(s) = 1$, and setting the initial conditions to zero, and defining an undamped natural frequency $\omega_n = \sqrt{K/J}$ and a damping ratio of $\zeta = B/(2\sqrt{KJ})$ the transfer function can be defined as

$$Y(s) = \frac{K}{Js^2 + Bs + K} \quad (4.7)$$

and a time domain solution can be derived as

$$y(t) = \frac{\omega_n}{\sqrt{1 - \zeta^2}} e^{-\zeta\omega_n t} \sin \omega_n \sqrt{1 - \zeta^2} t, \quad \zeta < 1. \quad (4.8)$$

Various techniques have been developed to analyze transfer functions. One technique in particular that has gained wide use in flying qualities analysis is the Bode diagram. The traditional Bode diagram, also known as the $j\omega$ -Bode diagram is constructed by varying s along the imaginary axis, holding σ constant, and varying the frequency ω as seen in the plot of the complex plane in Figure 4.2. By varying the frequency ω , the complex solution to $Y(s)$ can be plotted on a diagram. Since the complex solution is comprised of both magnitude and phase components, a three dimensional plot can be constructed, or two two dimensional plots can be made. The Bode diagram is the plotting of the magnitude and phase portions of the complex solution to $Y(s)$ by varying the frequency ω . Traditionally these plots are done on a semi-log axis. The Bode plot using Equation (4.4) can be seen in Figure 4.3.

Using transfer functions and block diagrams allows for a simple, graphical form where systems can be created and represented graphically as well as mathematically. Blocks can be combined and simplified to support mathematical analysis. An example of a feedback loop that is reduced can be seen in Figure 4.4.

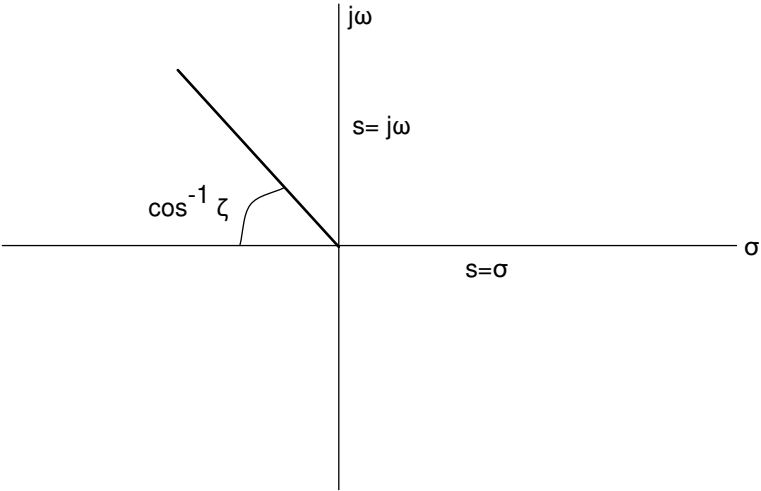

Figure 4.2: Plot of the complex plane.

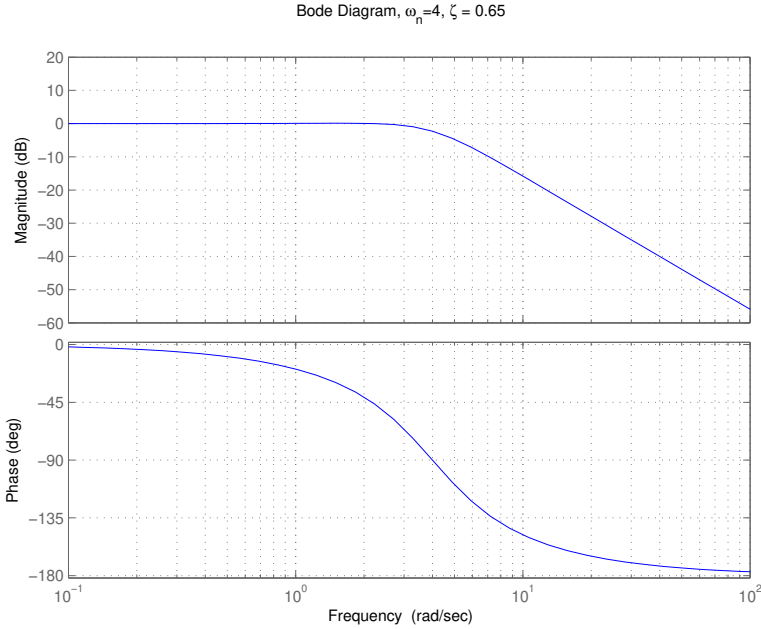

Figure 4.3: Example Bode diagram where $U(s) = \frac{\omega_n^2}{s^2 + 2\zeta\omega_n s + \omega_n^2}$

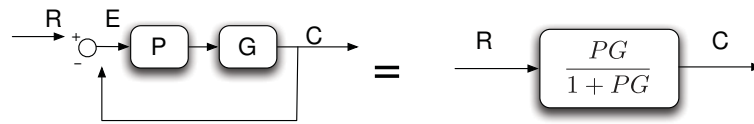

Figure 4.4: Example feedback block diagram reduction to single transfer function.

The 6 - DOF equations of motion of an aircraft as found in Equation (3.37) through Equation (3.48) lend themselves to linear systems analysis, and to further be reduced by splitting between longitudinal and lateral-directional motion. The longitudinal motion can be described by three degrees of freedom with the linear systems found in Equation (3.63) through Equation (3.67). The longitudinal motion linear equations can further be decomposed into two modes of motion that occur at separate frequencies, specifically the phugoid and short period modes. Since these modes can be considered separate, often analysis of each mode is done in a separate sense. The response of the two rigid body modes of an aircraft in longitudinal motion are the primary focus of aircraft flying qualities, since they dictate the response of the aircraft to pilot input.

4.2 Definition of Bandwidth

Two different definitions for bandwidth are used in analysis of aircraft. One definition is the classical definition of bandwidth as specified by electrical engineering applications. This definition of the bandwidth of a system is classically defined as the region of frequency where the gain of the closed loop system does not drop below -3 dB.⁹¹ The system found in Figure 4.5 is given as an example to illustrate the definition of bandwidth. A Bode plot of the closed loop system can be found in Figure 4.6, showing that the system gain response drops to -3 dB at 2 rad/sec, defining the system bandwidth as 2 rad/sec. The bandwidth therefore defines the range of frequency where the input signal can be tracked by the system, and the bandwidth frequency defines the frequency where the gain falls off from its low frequency value.

The flying qualities community has a second definition for system bandwidth as it is applied

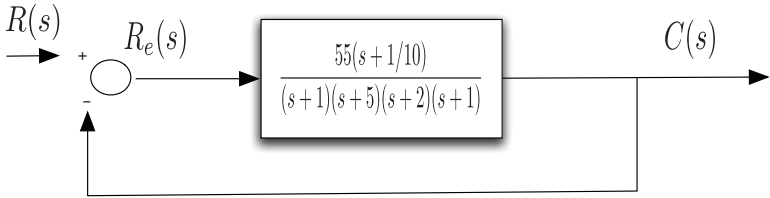

Figure 4.5: Example system diagram.

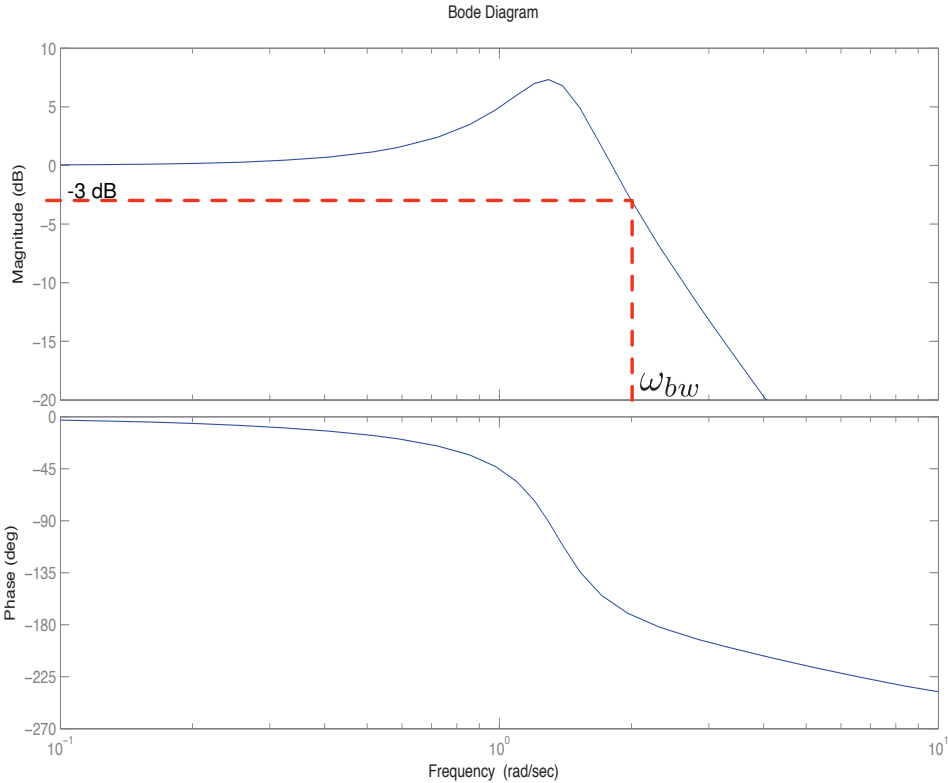

Figure 4.6: Example system diagram.

to flying qualities analysis. This definition of bandwidth was first offered by Hoh et al.⁹³ The flying qualities definition of bandwidth is “defined for handling quality criterion purposes [as] the frequency at which the phase margin is 45 deg or the gain margin is 6 dB, whichever frequency is lower.”⁹³ Using the aircraft short period with a pilot closing the total system loop as seen in the example system in Figure 6.7, a Bode plot can be constructed as in Figure 7.5. In this example, the $\omega_{bw \text{ gain}}$ would be the flying qualities bandwidth frequency, and the system would be seen as being gain limited. Using the gain and phase margin as parameters, the pilot can then have margin to double his gain or adjust time delay without causing an instability in aircraft control. It can be thought of as a measure of the limits of the closed loop system’s robustness. For a pilot, it is the highest frequency at which he can excite the aircraft while still feeling confident that the aircraft will have the inherent robustness to reject outside disturbances. The flying qualities bandwidth is shown as $\omega_{bw \text{ gain}}$ in Figure 7.5 and the traditional bandwidth value is found in as ω_{bw} in Figure 7.5.

These two definitions for bandwidth were created by two communities for different purposes. They will be compared and contrasted in their application to UAVs in Section 7.2.2.

Classification

FOLLOWING guidance from Chalk¹⁸ in suggesting changes to MIL-F-8785(ASG), the first step in defining a new flying qualities criterion is to determine classifications for the aircraft that will be evaluated by the new flying qualities criterion. While classifications exist for piloted aircraft, no flight mechanics based classification is currently available for UAVs. The DoD has issued four roadmaps for UAVs, in 2002,³³ another in 2005,⁹⁴ another in 2007,⁹⁵ and the most recent in 2009.⁹⁶ While each roadmap offers classes for UAVs, each one presents markedly different classes with each revision.

The 2002 roadmap simply lists UAVs as either Operational, Developmental, or Other. The 2005 roadmap expands this view and also moves away from the UAV acronym and uses the acronym UAS (Unmanned Aerial System) to encompass the entire air and ground system required to operate the air vehicle. It defines categories as : Major UAS , Concept Exploration UAS, Special Operations UAS, and Small UAS. In the Small UAS category, vehicle types are further broken down into Mini UA, Micro Air Vehicles (MAV), and Organic Air Vehicles (OAV). This view of UAVs (or UASs) is a systems engineering perspective of dividing UAVs. While this distinction creates a division based on mission and size of UAVs, it does not create a clear distinction between UAVs for delineating the dynamic response of aircraft. The 2007 roadmap changes focus from just UAVs (or UASs) to

unmanned systems (USs) of all kinds. It creates another set of categories from Level 0 to Level 5 based primarily on weight. This class description begins to follow more closely the classification used in MIL-F-8785(ASG). The 2009 roadmap classifies the air vehicle portion of USs by weight and FAA airspace integration boundaries.

By classifying UAVs they can be grouped together with other aircraft of similar characteristics. Due to the relatively small sample size of relevant data for UAVs, both RPVs and autonomous vehicles are analyzed together to find similarity in basic airframe dynamic response, focusing on airframe classes more than control classes. This study investigates “airplane like,” fixed-wing vehicles, excluding hovering vehicles, or launch (rocket powered) vehicles.

5.1 Creating a Framework

Using the manned aircraft requirements framework as a guide, a new framework was constructed for unmanned aircraft. The work done for manned aircraft has been widely accepted, and provides a good foundation for unmanned aircraft. Understanding the justification for the manned aircraft requirements framework gives insight that is required to create a new framework for unmanned aircraft. While unmanned aircraft show large differences from manned aircraft, similarities to manned aircraft should be exploited in creating a new set of requirements for unmanned aircraft.

5.1.1 Manned Aircraft Requirements Framework

In MIL-F-8785C⁵ piloted flying qualities are broken down by aircraft class, flight phase, and levels of performance. The manned aircraft classifications have traditionally been categorized into four different classes found in Table 5.1.

The classes are primarily delineated by gross weight and limiting load factor. This is “because they are considered to be gages of the maneuvering capability of an airplane and they reflect the mission for which it will be used.”¹⁸ The Flight Phase Categories are defined in Table 5.2.

These categories allow aircraft operation to be divided into different operational categories based

Class I	small, light-weight, medium maneuverability airplanes
Class II	medium-weight, low to medium maneuverability airplanes
Class III	large, heavy-weight, low maneuverability airplanes
Class IV	high-maneuverability airplanes

Table 5.1: Manned aircraft classifications as defined in MIL-F-8785C.

Category A:	Nonterminal flight phases that require rapid maneuvering, precise tracking, or precise flight path control.
Category B:	Nonterminal flight phases that are accomplished with gradual maneuvers (climb, cruise, descent)
Category C:	Terminal flight phases such as takeoff or landing

Table 5.2: Manned aircraft Flight Phase Categories as defined in MIL-F-8785C.

on tasks to be performed in the aircraft. The Levels then allow rating for flight safety and mission capability (1 - 3). Boundaries for a given flying qualities specification are then listed by class and category. These boundaries then specify a flying qualities level of one, two, or three for a given vehicle class and maneuver category.

As explained in the user guide for MIL-F-8785B(ASG)⁶ aircraft classifications were created using Figure 5.1. The chart uses a log axis for aircraft maximum gross weight, and a linear axis for load factor. It is important to note that there is overlap between the different aircraft classes. While today's aircraft designers primarily use intuition to state whether an aircraft is Class I, II, III, or IV it is important to note that there is a quantitative foundation for that intuition.

Significant interest has been placed on creating UAV classes based on mission.^{33,94,95} MIL-F-8785ASG¹⁶ originally did this with Class I: Primary trainer or observation, Class II: Bomber or cargo, and Class III: Fighter or interceptor. Aircraft grouped by these missions were later reclassified according to weight and load factor. The 2007 DOD US Roadmap lists 21 separate current and future missions for UAVs. All of these missions can be combined into the broad classes of strike

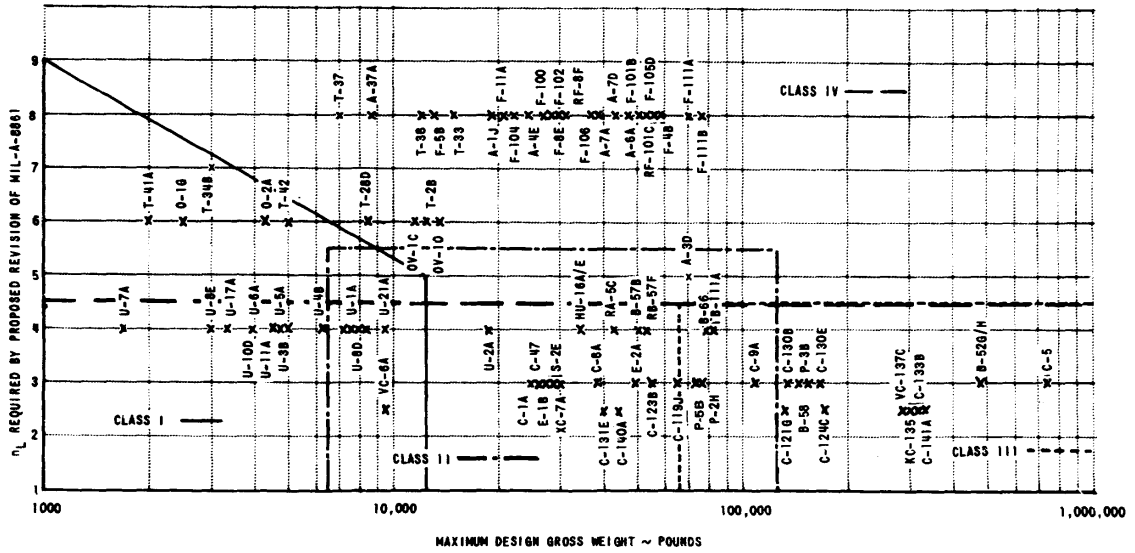

Figure 5.1: Operational aircraft comparison in user guide for MIL-F-8785B.⁶

and support, ISR and communication relay, and cargo / refueling tanker. Unlike manned aircraft systems, size and weight of the UAVs that support these missions are not specific to the mission. For example the Global Hawk and Hunter could both be considered ISR UAVs.

5.1.2 Aerodynamic Effects on Aircraft Dynamics

Aircraft motion is directly related to aerodynamic forces and moments. While this may seem a simplistic statement, it is worth reviewing the prevailing contributors to the forces and moments that affect aircraft motion. Anderson⁹⁷ describes lift, drag, and pitching moment as

$$L = f_L(V_\infty, \rho_\infty, S, \mu_\infty, a_\infty) \tag{5.1}$$

$$D = f_D(V_\infty, \rho_\infty, S, \mu_\infty, a_\infty) \tag{5.2}$$

$$M = f_M(V_\infty, \rho_\infty, S, \mu_\infty, a_\infty) \tag{5.3}$$

for a given angle of attack (α). In order to perform dimensional analysis on drag (D), assume force depends polonomially on the parameters:

$$D = ZV_{\infty}^b \rho_{\infty}^d S^e a_{\infty}^f \mu_{\infty}^g \quad (5.4)$$

where Z, b, d, e, f, g are dimensionless constants. Dimensional analysis can then be used to rewrite drag as

$$D = ZV_{\infty}^2 \rho_{\infty} S \left(\frac{a_{\infty}}{V_{\infty}} \right)^f \left(\frac{\mu_{\infty}}{\rho_{\infty} V_{\infty} S^{0.5}} \right)^g. \quad (5.5)$$

Recognizing that

$$M = \frac{V_{\infty}}{a_{\infty}} \quad Re = \left(\frac{\mu_{\infty}}{\rho_{\infty} V_{\infty} S^{0.5}} \right)^{-1} \quad (5.6)$$

drag can then be rewritten as

$$D = 2Z\bar{q}S \left(\frac{1}{M} \right)^f \left(\frac{1}{Re} \right)^g. \quad (5.7)$$

Using standard definitions of

$$\bar{q} = \frac{1}{2}\rho_{\infty}V_{\infty}^2 \quad C_D = \frac{D}{\frac{1}{2}\rho_{\infty}V_{\infty}^2 S} \quad (5.8)$$

the drag relationship can be rewritten as

$$C_D = Z \left(\frac{1}{M} \right)^f \left(\frac{1}{Re} \right)^g. \quad (5.9)$$

The same analysis can be performed on lift (L) and pitching moment (M) to yield

$$C_L = f_1(M_{\infty}, Re, \alpha) \quad C_D = f_2(M_{\infty}, Re, \alpha) \quad C_M = f_3(M_{\infty}, Re, \alpha). \quad (5.10)$$

A similar result can be shown for lateral and directional forces and moments. While this is well known, it is worthwhile to emphasize these relationships and that Mach number, Reynold's number, and angle of attack (or sideslip) have direct functional relationships to the forces and moments that

effect aircraft motion.

5.2 Study of Available Aircraft

5.2.1 Sources of Data Considered

Data for forty-two different aircraft were recorded from various sources.⁹⁸⁻¹⁰² These aircraft ranged from small UAVs to all four classes of piloted aircraft. Calculations were made to create plots of an operational Reynold's number vs. Mach number for each aircraft as well as Reynold's number vs maximum takeoff/launch weight for each aircraft. The data are shown in Figures 5.2 - 5.7. For the piloted aircraft, the calculations were done for a cruise configuration. The UAV calculations were done in a loiter configuration. Both cruise and loiter are considered Category B maneuvers in the piloted MIL-F-8785C specification. Cruise and loiter configurations were chosen since most of the aircraft's operational flight time would be spent in one or the other configuration. The data sets were plotted in this manner to determine possible groupings of aircraft that would confirm 8785C classes and possibly lend guidance towards classes of UAVs. Mach and Reynold's numbers were chosen because of their relationship to lift, drag, and pitching moment coefficients that in turn have a large impact on short period and phugoid mode natural frequency and damping ratio. Weight was also considered because of its effect on range and mission performance. Another motivating factor in choosing weight was that the aviation industry recognizes an informal rule: the production cost of an aircraft is directly proportional to its empty weight. That relationship is generally considered to be \$1500 per pound (FY94 dollars).³³ Adjusted for inflation, the FY10 rate is \$2200 per pound.¹⁰³

5.2.2 Results of Available Aircraft Study

A plot of operational Reynold's Number vs Mach Number was made for all forty-two aircraft, and can be seen in Figure 5.2. From this plot of data, a separation can be found between UAVs and manned aircraft. Distinguishing characteristics between different manned aircraft classes can also be determined. For example, transport category aircraft (Class III) are scattered, but well above other

aircraft. Fighter aircraft (Class IV) are grouped closely together at Mach 0.85 and at a Reynold's number of approximately 40 million. Medium weight aircraft (Class II) can be found lower and to the left of fighter aircraft. Small aircraft (Class I) can be found near the lower left of the chart. This chart also lends another perspective and some further insight into MIL-F-8785C Classes II, III, and IV beyond that found in Figure 5.1. In the far lower left corner, well below Mach 0.3 a large concentration of UAVs group together. Figure 5.3 shows a possible breakout of different manned aircraft classes and UAVs using the data from Figure 5.2. One observation from Figure 5.2 is that the different piloted aircraft begin to form groupings that reflect their Classes as found in MIL-F-8785C. Another observation is that UAVs collect in their own grouping, distinctly outside of the other class groupings. This would seem to suggest that UAVs would merit their own flying qualities specifications just as each class of aircraft does. The UAVs do not however seem to form distinct groups in the Figure 5.3.

Using the weight data gathered, another plot was created for all the aircraft in this study. This time Reynold's number vs. Gross Takeoff Weight was used to compare the aircraft as seen in Figure 5.4. Again, Class I, II, II, and IV aircraft group together, and an overlay of the different groupings can be seen in Figure 5.5. In this plot there is considerable overlap between Class IV and Class II manned aircraft. This is intuitive, since they cruise (operate) at similar conditions and are primarily distinguished by maneuverability. As in Figure 5.1 the primary discriminator for these aircraft is design load factor. With the exception of Global Hawk, the UAVs again are found at the lower left of the chart. Figure 5.5 highlights a separation between UAVs and manned aircraft. Another interesting observation is that all the aircraft tend to form a linear trend when viewed on a log-log scale, with the UAVs dominating the bottom end of the scale. Figure 5.6 adds boundaries denoting Domestic Use UAS levels as specified in Figure A.4 in the Unmanned Systems Roadmap 2007-2032.⁹⁵ These levels only make use of system weight as the discriminator between aircraft levels. Reexamining these boundaries, a new trend can be found to discriminate UAV classes. A new trend can be identified in Figure 5.7, where aircraft of similar operation, mission, and size are

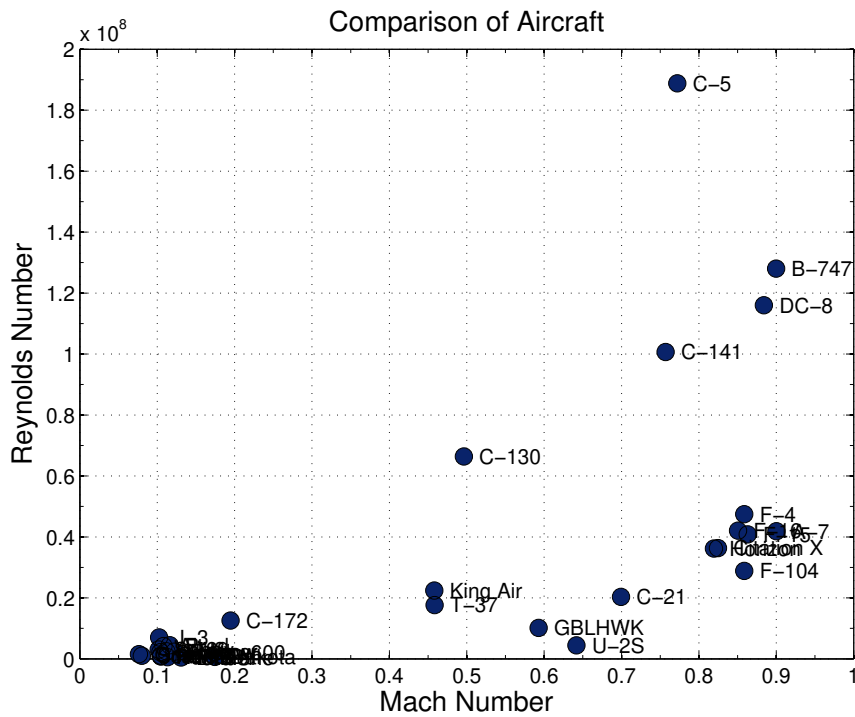

Figure 5.2: Aircraft operational comparison by Reynold's and Mach numbers.⁹⁸⁻¹⁰²

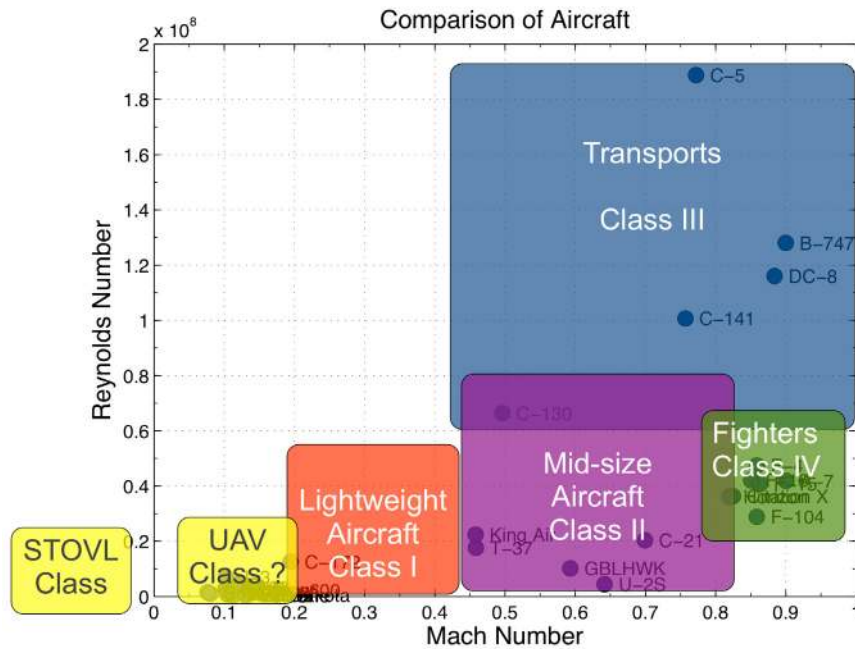

Figure 5.3: Aircraft operational comparison by Reynold's and Mach numbers with manned aircraft classes overlaid.^{5,98-102}

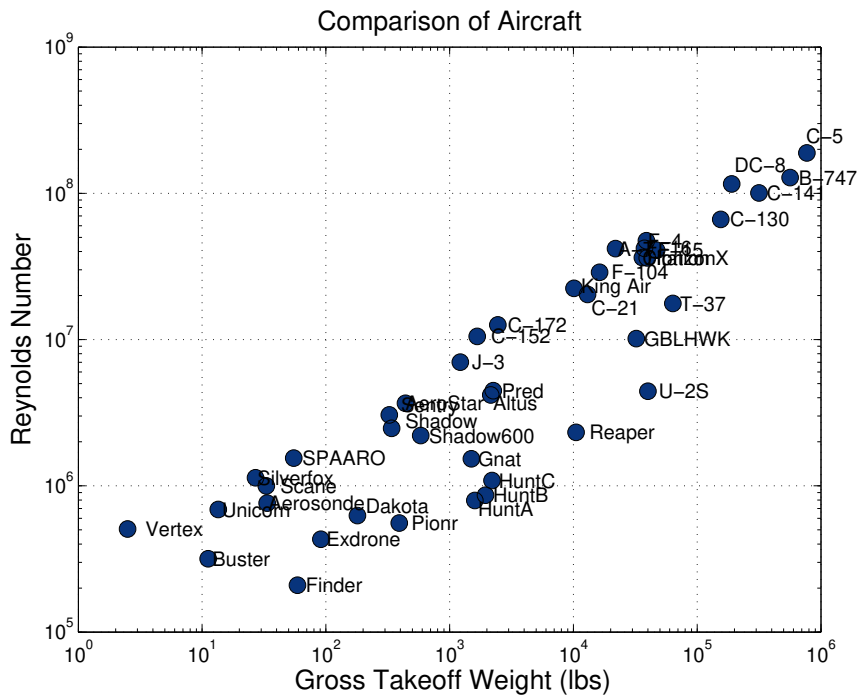

Figure 5.4: Aircraft operational comparison by Reynold’s number and weight.⁹⁸⁻¹⁰²

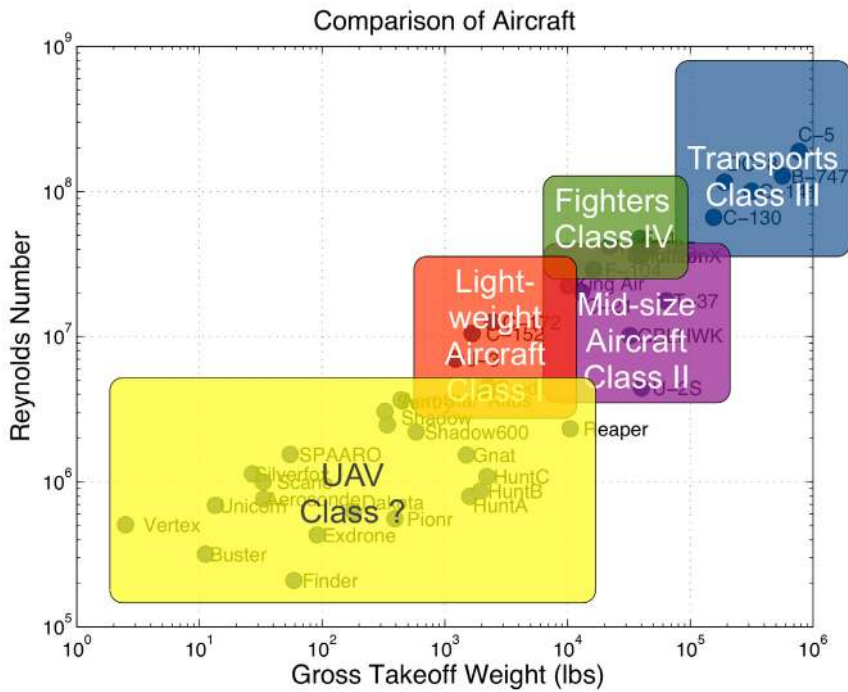

Figure 5.5: Aircraft operational comparison by Reynold’s number and weight with manned aircraft classes overlaid.^{95,98-102}

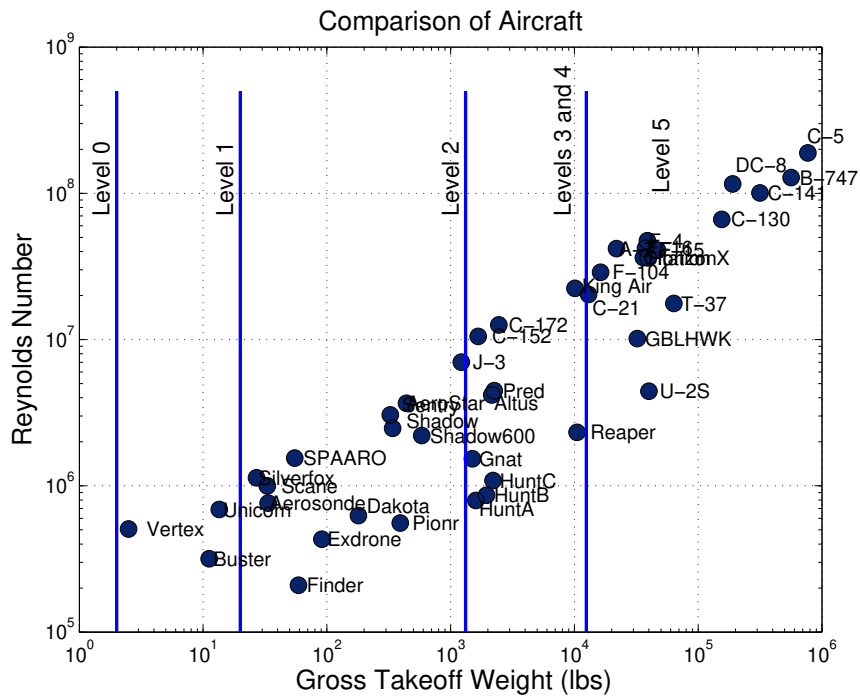

Figure 5.6: Aircraft operational comparison by Reynold’s number and weight, with UA 2007 Roadmap Levels overlaid.^{95,98–102}

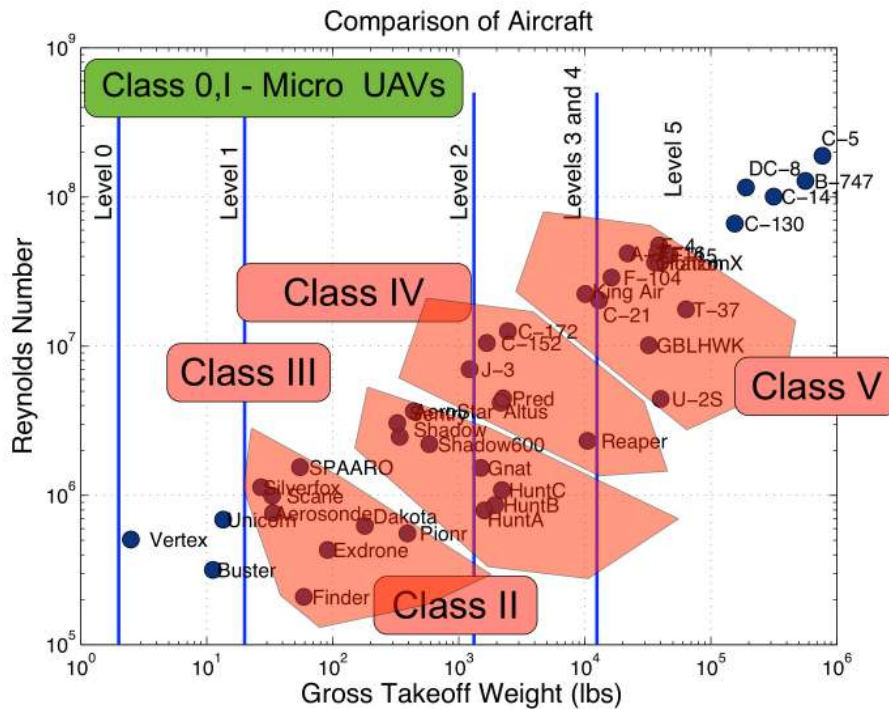

Figure 5.7: Aircraft operational comparison by Reynold’s number and weight, with proposed UAV classes overlaid.^{98–102}

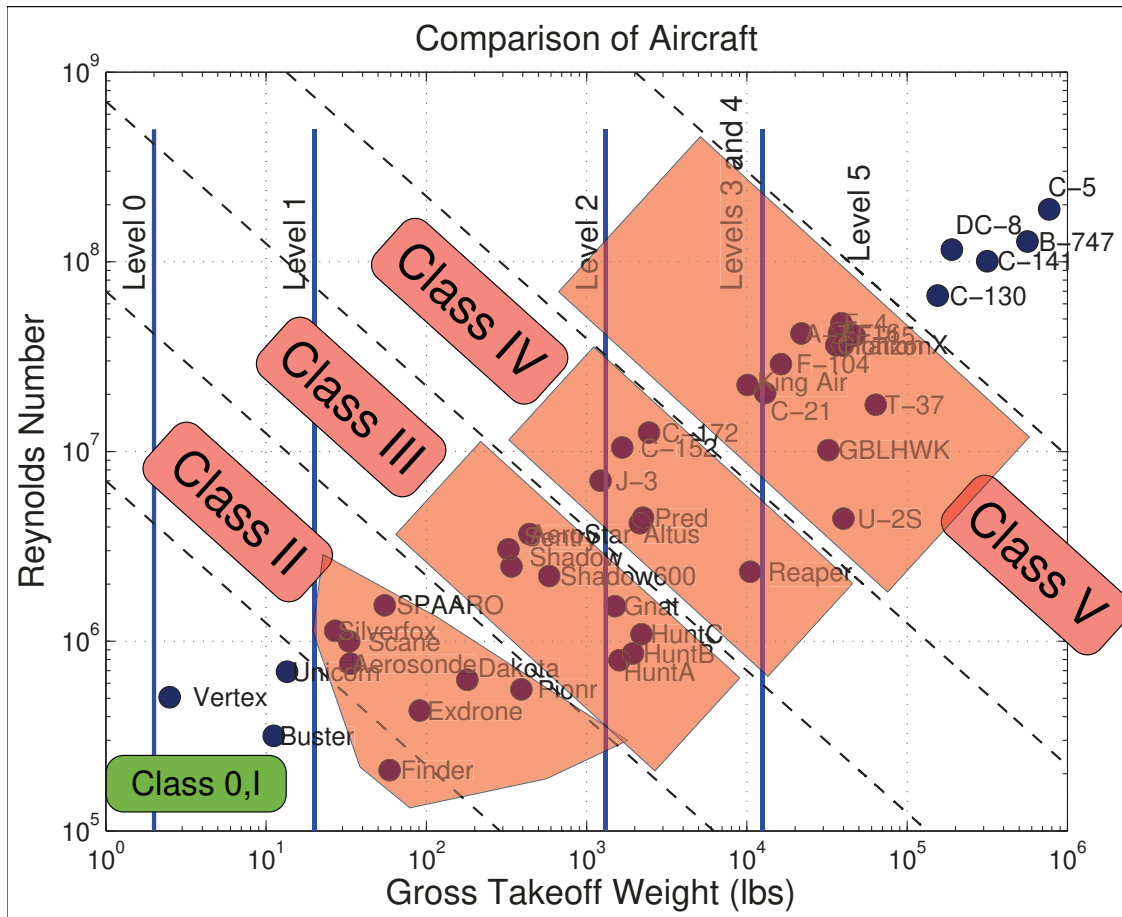

Figure 5.8: Aircraft operational comparison by Reynold’s number and weight, with proposed UAV classes and trend lines overlaid.^{98–102}

b (y-intercept)	a (slope)
7E6	-0.75
7E7	-0.75
7E8	-0.75
7E9	-0.75
3E11	-0.75

Table 5.3: Definition of classification separation lines.

grouped together. These classes can be further refined in Figure 5.8. Here the aircraft are separated by lines of the form

$$y = bx^a \quad (5.11)$$

where b and a are defined in Table 5.3. Using the coefficients as defined in Table 5.3, Equation (5.11) takes the form of Equation (5.10) showing an inversely proportional relationship between Reynold's number and weight, similar the relationship between Reynold's number and coefficient of lift. The Reynold's number is nondimensionalized with a unit of length, usually the wing chord. The aircraft weight in trimmed flight is the aircraft's lift, which is nondimensionalized with a unit of area, usually the wing planform area. These two parameters combined can therefore take into account the wing geometry of the vehicle. By taking into account Reynold's number and weight; derivative aircraft can now be grouped together. This also allows such similar aircraft as the Sentry, Shadow, and Hunter series to all be grouped together. The inclusion of Reynold's number provides for the consideration of operational altitude and operational speed when classifying aircraft, which is currently lacking in a weight-only distinction as seen in Figure 5.6. Another advantage is that Predator derivative aircraft can be compared directly to small aircraft such as the Piper J-3 Cub and Cessna 172. The Global Hawk aircraft can also be placed into a similar classification with the U-2 and other mid-sized aircraft. Further, the possibility now exists for of a much lighter UCAV to be placed into a classification with current manned strike aircraft. The Class II vehicles shown in Figure 5.8 include smaller and slower UAVs such as the Scan Eagle, Dakota, Pioneer, Exdrone, and Finder. Class I vehicles would include the Vertex, Unicorn, and Buster. The Class 0 vehicles,

or very light weight UAVs (such as micro air vehicles) were not included, due to a lack of available data. Intuitively, these would merit a separate class.

Figure 5.9 shows the same data used in Figure 5.8 within the boundaries defined in the JUAS COE classification. Currently no UAVs fall into class 4 of the figure. Table 5.4 then compares the proposed classification method against the JUAS COE method. The 8785C Class column gives the piloted aircraft classification, while the JUAS COE (Joint Unmanned Aircraft Systems Center of Excellence) column gives the classification as defined in the 2009 Unmanned Systems Integrated Roadmap.⁹⁶ The proposed changes to UAV classifications can be found in the Proposed Class column of this table. This new classification would allow specifications to be tied to aircraft weight and ultimately cost, as well as an operational Reynold's number to aid in determining aerodynamic effects.

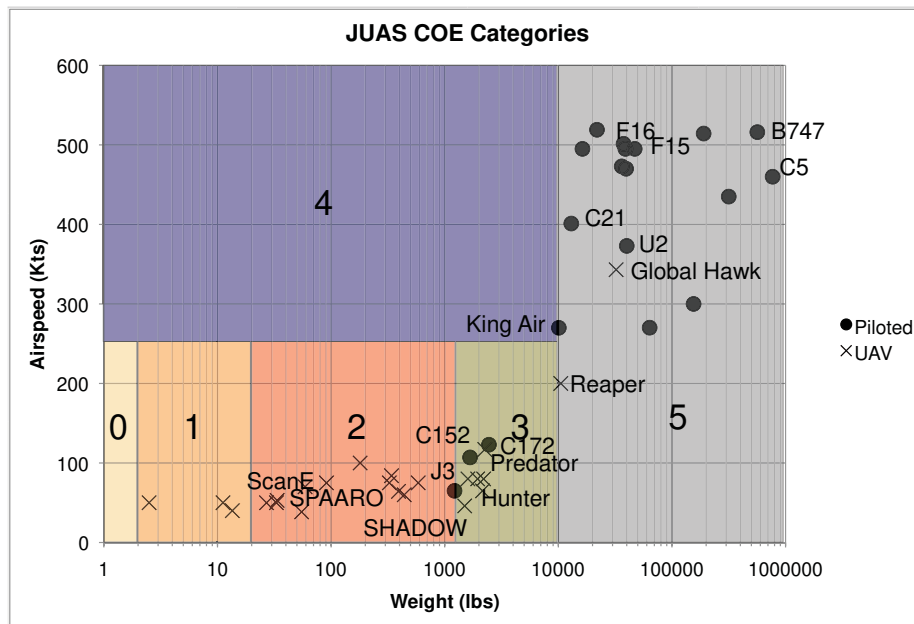

Figure 5.9: JUAS COE classification boundaries as described in the 2009 Unmanned Systems Integrated Roadmap.⁹⁶

Piloted Aircraft	8785C Class	Unmanned Aircraft	JUAS COE Levels	Proposed Class
F-16	IV	Shadow	2	III
F-15	IV	Shadow600	2	III
C-130	III	Sentry	2	III
C-141	III	Altus	3	IV
C-5	III	Gnat	3	III
B-747	III	Global Hawk	5	V
DC-8	III	Predator	3	IV
C-21	II	Reaper	3	IV
F-104	IV	Scan Eagle	2	II
F-4	IV	Pioneer	2	II
A-7	IV	Hunter A	3	III
T-37	II	Hunter B	3	III
Cessna 172	I	Hunter C	3	III
Piper J-3 Cub	I	Dakota	2	II
King Air	II	Exdrone	2	II
Citation X	II	Finder	2	II
Horizon	II	Aerosonde	2	II
Cessna 152	I	AeroStar	2	III
U2-S	II	Buster	1	I
		Unicorn	1	I
		Silverfox	2	II
		Vertex	1	I
		SPAARO	2	II

Table 5.4: Aircraft (manned and unmanned) used in comparison

5.3 Payload/Sensor Study

Part of the original intent of this study was to not only classify UAVs but to also classify the payload/sensor packages they carry. By classifying payload/sensor packages, ultimately a compatible set of classifications of UAVs and payloads could be defined. Unfortunately very little information describing payload/sensor packages for military applications is publicly available. Thirty-two payloads were found in *Jane's Unmanned Aerial Vehicles and Targets*⁹⁸ and collected in Table 5.5. From the available data the payloads were then collected into similar types in Table 5.6. Since sensor dynamic information was not available for this study, an alternate method was employed to

account for sensor dynamics in the creation of the flying qualities criterion. For the purpose of this study, simple first order system will represent the CloudCap[®] TASE gimbaled camera.

5.4 Conclusion

UAVs are at a similar point of development as conventional aircraft during the 1950's where flying qualities requirements were developed to aid in procurement of future systems. While early work has been done to define RPV flying qualities by dynamic scaling, further work is needed to define full scale aircraft that are analogous to different UAVs. Work is also required to determine flying qualities criteria for autonomous UAVs, which may not have full scale analogues. The first step toward focusing UAV flying qualities development is to define classes of UAVs, an example of which is presented in this paper.

From inspection of Reynold's Number and Mach number it is apparent that piloted aircraft do collect into groupings that fall along the lines of traditional classes used for flying qualities analysis. UAVs have been shown to fall outside of these traditional classes. Using Reynold's number and weight it has been shown that UAVs begin to form groups or classes that can be divided similar to piloted vehicles. This work has been done to define a method for UAV classification for flying qualities analysis. One vehicle from each UAV class will be chosen as representative of its class to aid in development of a UAV flying qualities criterion.

Results that would aid in the further refinement of UAV class definition boundaries would be design limit normal acceleration, as well as bare airframe short period and phugoid modal responses. While this data was not available for this study, collecting this information on future UAVs could aid in future refinement of UAV classification.

Sensor	Manufacturer	Type
D-500	BAE	Infra-red linescanner
Series 52	BAI	laser range finder PTZ camera
Series 66	BAI	daylight TV and IR
Apache	FLIR Systems	Camera IR
BRITE Star	FLIR Systems	IR, TV, laser designator & rangefinder
MK II	FLIR Systems	Sensor Turret
Photon	FLIR Systems	IR Camera core
StarSAFIRE III	FLIR Systems	IR, TV, laser illuminator, rangefinder
Ultra 7000/MicroSTAR	FLIR Systems	IR , TV
Ultra 8500	FLIR Systems	IR, TV, laser designator & rangefinder
AN/APY-8 Lynx	General Atomics	SAR
Lynx II	General Atomics	SAR
microSAR	IMI	IR Camera
miniSAR	IMI	SAR
CAM-NOIR	Irvine	SAR
RM-3000	L3	Solid state recorder
RM-8000	L3	Solid state recorder
AD-G/EXJAM	Lockheed Martin	Comm Jammer
IR-G600	Mitsubishi	Thermal Imager
IR-M700	Mitsubishi	Thermal Imager
AN/ZPQ-1 TESAR	Northrop Grumman	SAR
LR-100	Northrop Grumman	ESM/ silent sensor
Raven Eye I	Northrop Grumman	electro-optic
Raven Eye II	Northrop Grumman	electro-optic
TUAVR	Northrop Grumman	SAR
AN/AAS-44V	Raytheon	Thermal Imager
AN/AAS-52 MTS	Raytheon	Multisensor targeting
UltraLite	Raytheon	silent payload
SU320MVis-1.7RT	SUI	visible light and SWIR camera
SU320MX-1.7RT	SUI	NIR camera
SU320US-1.7RT	SUI	SWIR camera
SU640SDV-1.7RT	SUI	SWIR camera

Table 5.5: Sample payloads found in research for this report

Payload Type	Total Found
IR Camera	8
TV Camera	9
Turret	1
SAR	6
Recorder	2
Jammer	1
Imager	3
Passive	2
SWIR	3
Rangefinder	4
Designator	3

Table 5.6: Payloads from Table 5.5 reduced to general classes.

Review of Manned Flying Qualities

TO develop flying qualities standards for unmanned aircraft, the first step taken was to categorize UAVs according to parameters that influence their dynamic response. This categorization method is documented in Chapter 5. The next step in creating a new flying qualities standard is to review prominently used piloted flying qualities standards to determine if any are applicable to unmanned aircraft. Modifying existing standards will allow for a faster development of a criterion as well as general familiarity and acceptance within the aerospace community. This report provides a review of current manned flying qualities criteria that are in use today with a focus on their applicability to unmanned aircraft. Documents reviewed include the following as well as their original, source works where applicable.

1. AFFDL-TR-T25, RPV Flying Qualities Design Criteria³⁵
2. MIL-F-8785C, Military Specification, Flying Qualities of Piloted Aircraft.⁵
3. MIL-HDBK-1797, Flying Qualities of Piloted Aircraft¹⁰⁴
4. SAE94900 Aerospace - Flight Control Systems - General Specification for Design, Installation and Test of Piloted Military Aircraft¹⁰⁵
5. NASA TN D-5153, The Use of Pilot Rating in the Evaluation of Aircraft Handling Qualities²³

6. ADS-33E-PRF, Aeronautical Design Standard Performance Specification Handling Qualities Requirements for Military Rotorcraft¹⁰⁶

The review of these documents focused on longitudinal flying qualities criteria, especially in the frequency domain. The findings of that review are presented in this chapter.

6.1 AFFDL-TR-T25, RPV Flying Qualities Design Criteria

This document was the product of phase II of a four phase AFFDL/FGC program plan to develop a RPV Flying Qualities Specification. Its primary purpose was “to develop a preliminary framework for RPV flying qualities criteria which could be expanded, refined, and validated by simulation and analysis...”³⁵ The document contains a compilation of MIL-8785B, MIL-F-83300, MIL-F-9490D, and MIL-C-18244A into a new design guidance document for use by RPVs.³⁵ Specific tailoring of requirements to autonomous UAVs was not done in this study, since the work was done specifically for RPVs without mention of autonomously operating UAVs. The Naval Air Warfare Center has also published results from applying and then testing modified manned flying qualities criteria to small scale RPVs³⁶ using similar techniques to those used in AFFDL-TR-T25. Work has also been done to show that short period natural frequency requirements should be different for small UAVs compared to traditional aircraft.^{41,46} Using dynamic scaling, both reports suggested modifying the CAP criterion found in Section 6.2 using different natural frequency boundaries for small UAVs versus full scale piloted aircraft. While they identified the need for added time delay, and cited specifications for remote human operation, the CAP criterion is only applicable to bare airframe dynamics or stability augmented control. It does not address autonomous aircraft control in enough detail to be applicable to autonomous UAVs. The criteria in AFFDL-TR-T25 is therefore not reviewed in this section, but is reviewed later in the discussion of MIL-HDBK-1797 and MIL-F-8785C.

6.2 MIL-F-8785C

The primary focus of longitudinal flying qualities requirements in MIL-F-8785C is unaugmented, piloted aircraft. Specifically the short period and phugoid modes are specified using criteria based on a human operator's ability to act as the aircraft's augmentation and control system. The phugoid mode specifications listed in MIL-F-8785C are not changed from MIL-F-8785B.¹⁰⁷ Requirements for phugoid stability in MIL-F-8785B are based primarily on pilot comments, specifically during landing tasks.⁶ The flight path stability requirements in MIL-8785C also trace heritage to MIL-F-8785B, and specifically to landing tasks. All of these requirements were empirically derived from pilot comment. The phugoid requirements are directly linked to gust rejection ability of the pilot/aircraft system. While these values may be used as a guide for determining gust rejection characteristics for aircraft with a control system base on human response times and perceptions, there is no quantitative correlation between these values and unmanned aircraft. Since the primary guide to determine these values was pilot input on unaugmented aircraft, their applicability to autonomous UAVs is limited to those that are designed to match piloted aircraft dynamics for landing purposes or gust rejection, irrespective of the UAV's control system.

Original flying qualities criteria for short period dynamics were based on a "thumbprint" plot of short period undamped natural frequency vs. short period damping ratio.¹⁹ This criterion did not account for the zero in the numerator of the short period transfer function, specifically $1/T_{\theta_2}$. Bihrlle¹⁰⁸ introduced the control anticipation parameter (CAP) to account for the short period transfer function numerator. It is considered one of the earliest and most used piloted flying qualities criteria, especially for unaugmented aircraft. While CAP was first introduced in 1965, it continues to be used in modern standards, including MIL-HDBK-1797. Modern updates to pitch stability requirements can still trace heritage to CAP, including a dynamic margin constraint proposed by Phillips and Niewoehner.¹⁰⁹

The CAP is ratio of the aircraft's pitch acceleration to change in steady state load factor. This ratio

correlates the sensitivity of the human vestibular organ to pitch acceleration to a sensed g-loading of an aircraft. The human vestibular system is very sensitive to pitch acceleration and is the first feedback to the pilot that the aircraft is changing motion. The desired aircraft pitch change results in an angle of attack (α), and ultimately a change in g-loading on the aircraft as the flight path changes. This g-loading (n_z) of the aircraft is sensed by the pilot and is used to command aircraft flight path. Closing this loop by the human requires that the dynamic relationship between pitch attitude acceleration and aircraft loading be within human sensing capabilities. To derive CAP, first observe that the aircraft pitch acceleration can be represented as

$$\ddot{\theta} = \frac{\bar{q}S\bar{c}C_{m_\delta}\delta}{I_{yy}} \quad (6.1)$$

and take the change in aircraft loading as

$$\Delta n_{ss} = \frac{-\left[1 + \frac{C_{m_{C_L}}}{l_t/\bar{c}}\right] C_{m_\delta} \Delta\delta}{C_{m_{C_L}} C_L + \frac{\bar{c}g}{2V^2} C_{m_{\dot{\theta}}}} \quad (6.2)$$

By dividing Equation (6.1) by Equation (6.2) CAP can be defined as

$$CAP = \frac{\ddot{\theta}}{\Delta n_{ss}} = \frac{W\bar{c}C_{m_{C_L}} + 0.25S\bar{c}^2\rho gC_{m_{\dot{\theta}}}}{-I_{yy}\left[1 + \frac{C_{m_{C_L}}}{l_t/\bar{c}}\right]} \quad (6.3)$$

The natural frequency of the short period mode can be derived¹⁰⁸ to be

$$\omega_n = \sqrt{\frac{L_\alpha}{W} \frac{W\bar{c}C_{m_{C_L}} + 0.25S\bar{c}^2\rho gC_{m_{\dot{\theta}}}}{-I_{yy}}} \quad (6.4)$$

where

$$L_\alpha = qSC_{L_\alpha} \quad (6.5)$$

Combining Equation (6.3) and Equation (6.4) yields

$$CAP = \frac{W}{L_\alpha} \omega_n^2 \left[\frac{1}{1 + \frac{C_{mCL}}{l_t/\bar{c}}} \right] \quad (6.6)$$

The fractional term is approximately 1, leaving

$$CAP = \frac{W}{L_\alpha} \omega_n^2 \quad (6.7)$$

The aircraft load factor per unit angle of attack can be taken to be

$$n_\alpha = \frac{L_\alpha}{W}. \quad (6.8)$$

CAP can therefore be reduced to

$$CAP \approx \frac{\omega_n^2}{n_\alpha} \quad (6.9)$$

This expression gave rise to the short period frequency requirements found in MIL-F-8785C,⁵ specifically charts such as the one found in Figure 6.1.

Chalk et al.⁶ offer another derivation of CAP. Using Equation (3.69) and Equation (3.73) as a starting point, they assume constant-speed in order to focus on the short period mode. They then apply the initial value theorem to the $\ddot{\theta}/\delta_e = s^2\theta/\delta_e$ transfer function and the final value theorem to $n/\delta_e = n/(g\delta_e)$ transfer function. After algebraic reduction, the following expression can be obtained

$$CAP = \frac{\ddot{\theta}}{\Delta n_{ss}} = \frac{\omega_n^2}{g \frac{1}{T_{\theta_2}}}. \quad (6.10)$$

$(1/T_{\theta_2})$ is the numerator lead factor in the constant speed θ/δ_e transfer function.

$$\frac{1}{T_{\theta_2}} = \frac{Z_{\delta_e} M_w - M_{\delta_e} Z_w}{M_{\delta_e} + Z_{\delta_e} M_{\dot{w}}} \quad (6.11)$$

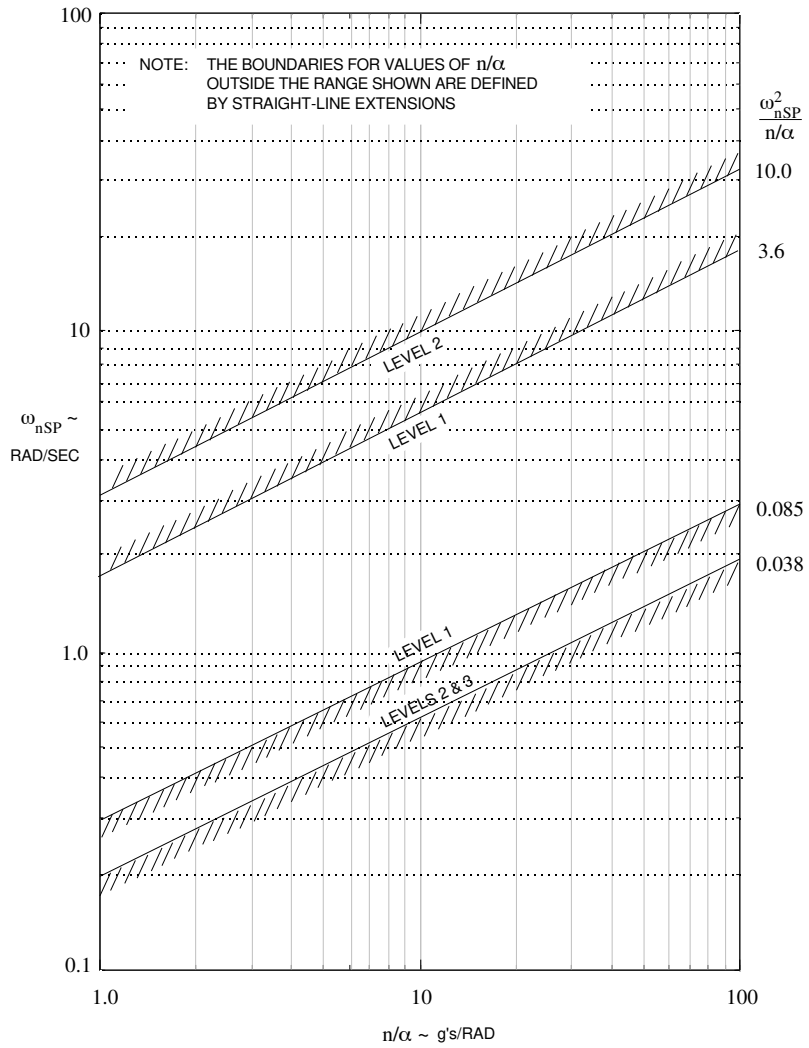

Figure 6.1: Natural frequency specification for Category B flight phases, MIL-F-8785C.⁵

It is valid in this case to assume $\|M_{\delta_e}\| \gg \|Z_{\delta_e} M_{\dot{w}}\|$ and that $\|M_{\delta_e}\| \gg \|Z_{\delta_e} M_q\|$, reducing

$$\frac{1}{T_{\theta_2}} \approx \frac{Z_{\delta_e} M_w - M_{\delta_e} Z_w}{M_{\delta_e}} \approx \frac{g}{V} \frac{n}{\alpha} \quad (6.12)$$

Substituting Equation (6.12) into Equation (6.10) then yields Equation (6.9).

Bihrlé recommends that CAP be maintained above $25 \frac{\text{degrees}}{\text{second}^2 g}$, and that the lower critical value is 15.¹⁰⁸ These recommendations lead to the boundaries as seen in Figure 6.1.

The relation between flight path and attitude is reported by Mitchell²⁵ as

$$\frac{\gamma}{\theta} = \frac{1}{T_{\theta_2} s + 1} \quad (6.13)$$

The values recommended by Bihrlé reflect the human pilot's perception of motion of the aircraft, and the pilot's ability to react and then control the aircraft's short period mode. While the mathematical concepts of CAP would be applicable to an unpowered aircraft, the numerical relationships would not be applicable, unless the vehicle's sensors and control system are designed to mimic human function. One major drawback to using a purely CAP criterion is that almost all autonomous UAVs possess a stability augmentation system, which would modify the bare airframe dynamics. The higher order systems that arise from vehicle augmentation can not be specified using CAP. The need to apply a Low Order Equivalent Systems (LOES) approach to account for higher order modes is discussed by Moorhouse,¹⁰⁷ although no explicit requirements criterion is called out in MIL-F-8785C. LOES as well as other higher order criteria are mentioned in MIL-F-8785C, although they appear in a more mature form in MIL-STD-1797 (later revised to MIL-HDBK-1797), and are covered in that section of this report. It is important to note that ignoring the effects of high order systems can have disastrous results. One example of ignoring the effects of the higher order modes can be seen in Harris and Black¹¹⁰ where they discuss the YF-22 PIO that resulted in the loss of an aircraft.

6.3 MIL-HDBK-1797

As aircraft with stability augmentation systems became more prevalent, the need to specify their flying qualities with criteria that expanded beyond CAP increased. The primary consideration beyond that specified with CAP was the time delay associated with the higher order modes introduced with stability augmentation systems. This added time delay adversely affected aircraft handling, requiring the new criteria to be introduced. The reference that documents these new flying qualities criteria is MIL-HDBK-1797.

6.3.1 LOES

Early work by DiFranco,¹¹¹ as well as Neal and Smith¹¹² and Hodgkinson¹¹³ determined that classical systems for aircraft specifications were not adequate for digital control systems where high order modes are introduced. High frequency phase lags associated with higher order systems can not be accounted, and required a methodology to map higher order systems into lower order systems. This gave rise to the low order equivalent systems (LOES) approach.¹¹⁴ Hodgkinson¹¹⁴ cites an example using transfer functions to explain the basic principles of LOES. Figure 6.2 and Figure 6.3 are Bode plots of :

$$\text{transfer function 1} \quad K \frac{s + 0.7}{(s^2 + 4s + 4)(s^2 + 16.8 * s + 144)} \quad (6.14)$$

$$\text{transfer function 2} \quad K \frac{s + 0.7}{(s^2 + 4s + 4)} e^{-0.12s} \quad (6.15)$$

$$\text{transfer function 3} \quad K \frac{s + 0.7}{(s^2 + 4s + 4)} \quad (6.16)$$

The traces in Figure 6.2 clearly show the difference in phase when part of the denominator from Equation (6.14) is omitted. By approximating this loss with a time delay as in Equation (6.15) the time delay incurred from the high order transfer function can be recovered. Boundaries have been

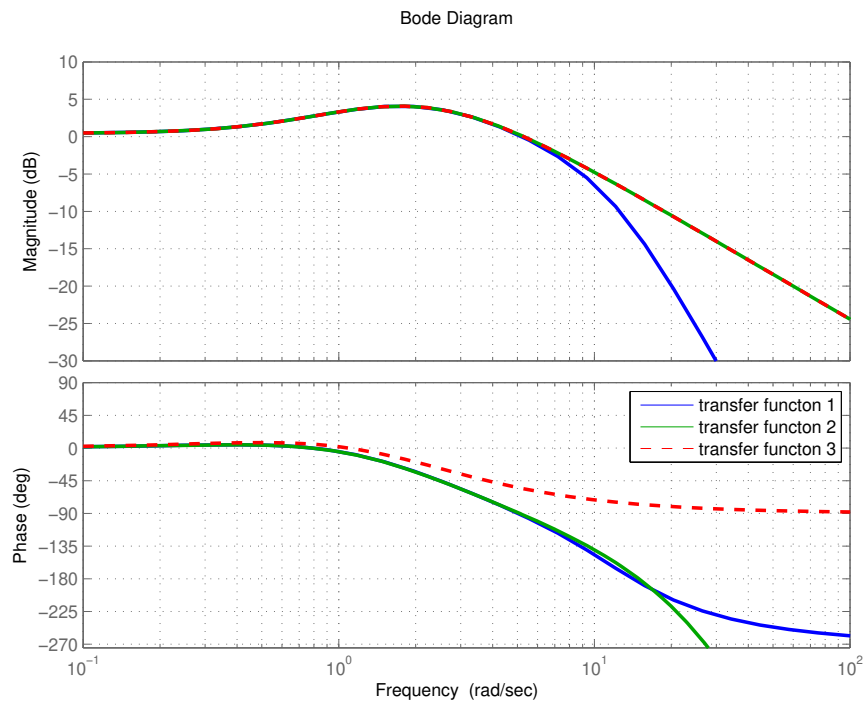

Figure 6.2: Example transfer functions to illustrate LOES.¹¹⁴

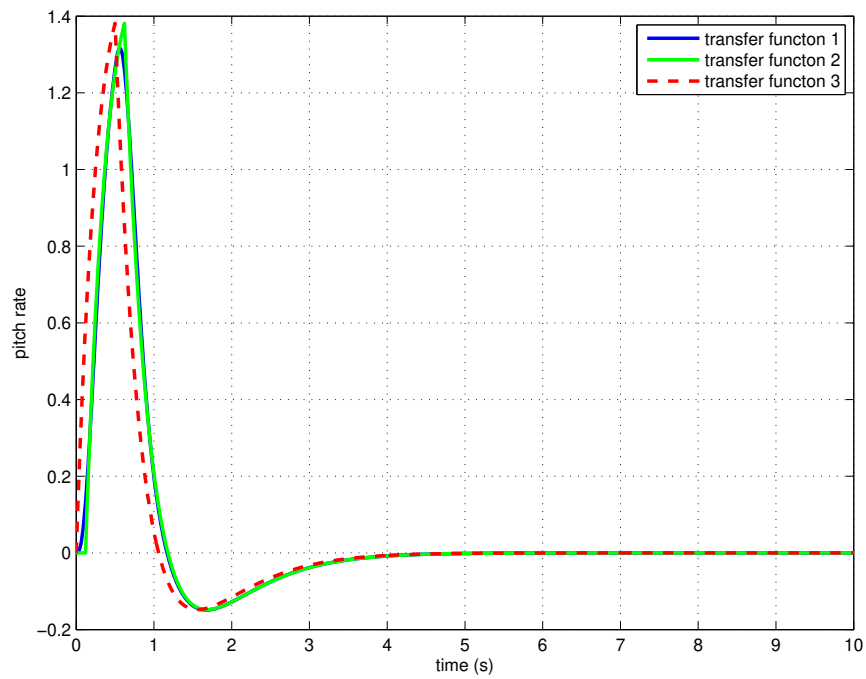

Figure 6.3: Example transfer function time histories to illustrate LOES.¹¹⁴

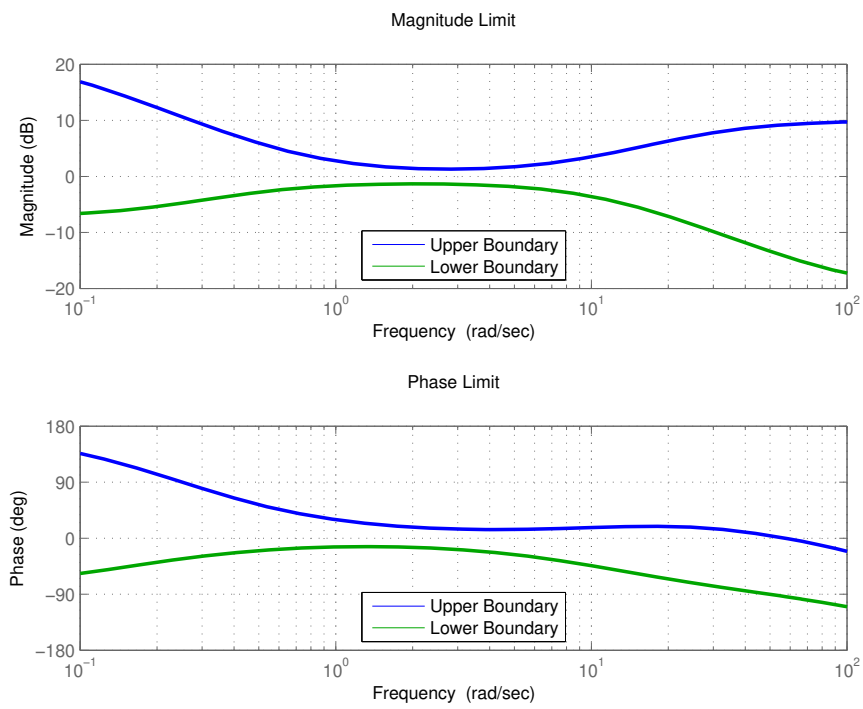

Figure 6.4: LOES boundaries for matching high order to low order transfer functions.¹¹⁵

set for LOES matching by Wood and Hodgkinson.¹¹⁵ An example of these boundaries can be seen in Figure 6.4. These boundaries were primarily set using the NT-33 in-flight simulation aircraft with work done by Neal and Smith.¹¹² The boundaries are set to allow the maximum unnoticeable added dynamics (MUAD) as perceived by a human pilot. If a response goes beyond the MUAD boundary, the aircraft response will no longer be “close enough to a typical airplane” so that an average pilot would be able to comfortably control the vehicle. These boundaries shrink around the region where the cross over frequency for a given mode should occur. This weights the matching of the low and high order systems at the frequency region that is the most important, while relaxing the matching criteria at low and high frequencies. The boundaries specified in Figure 6.4 can be described mathematically as:

$$\text{Upper Magnitude Boundary} \quad \frac{3.16s^2 + 31.61s + 22.79}{(s^2 + 27.14s + 1.84)} \quad (6.17)$$

$$\text{Lower Magnitude Boundary} \quad \frac{9.55E - 2s^2 + 9.92s + 2.15}{(s^2 + 11.60s + 4.95)} \quad (6.18)$$

$$\text{Upper Magnitude Phase} \quad \frac{68.89s^2 + 1100.12s + 275.22}{(s^2 + 39.94s + 9.99)} e^{-0.0059s} \quad (6.19)$$

$$\text{Lower Magnitude Phase} \quad \frac{475.32s^2 + 184100s + 29456.1}{(s^2 + 11.66s + 3.89E - 2)} e^{-0.0072s} \quad (6.20)$$

The boundaries defined focus on the crossover frequency range where piloted modes typically are found. These boundaries, drawn to minimize MUAD, may not be applicable to an unpiloted vehicle whose modes can be defined as desired. For unmanned aircraft the boundaries would have to be redefined to allow focus to remain on the crossover frequency region, no matter where it may lay in the frequency spectrum. Further Mitchell and Hoh²⁵ do cite concerns where lead-lag augmentation occurs near a vehicle’s short period frequency. Hodgkinson¹¹⁴ however does point out that all flying qualities criteria must use some level of higher order to lower order matching, and that LOES provides the least level of mismatch. Another concern in using LOES relates to the boundaries as seen in Figure 6.4. These boundaries are drawn under the assumption that a conventional response

is expected from the aircraft. In the case that a rate command attitude hold, or an attitude command attitude hold response is required, the boundaries for LOES would have to be redefined. The use of nonconventional response types to best meet different mission task elements (MTEs) may be required, and in the case of UAVs the possibility exists for other permutations of response types beyond those typically used with a human pilot.

6.3.2 Neal-Smith

The Neal-Smith criterion^{26,112} is widely known for its large database of piloted data that was used in its creation. The criterion uses frequency based analysis to specify requirements for a pitch tracking task. This criterion was one of the first to use a simplified pilot model to create a closed-loop analysis method for piloted aircraft. The model used by this criterion can be found in Figure 6.5. The criterion assumes that the pilot closes a visual-tactile loop around the controlled aircraft. The assumption is made that the pilot will adjust his gain and phase compensation to permit the pitch tracking task. The pilot's gain and phase compensation then determines the pilot's perception of the aircraft's flying qualities. The criterion uses pitch rate command response to measure a closed loop resonance, which can vary depending on the pilot's ability to add lead or lag compensation. By fixing the a minimum bandwidth frequency of 3.5 rad/sec , and knowing the open loop frequency response, the pilot's compensation required to complete the task can be measured. This criterion is geared specifically to the human pilot's ability to adapt to a given system, and does not show a direct correlation to a system that is unmanned. Further, later work with this criterion led to the Bandwidth criterion¹¹⁴ where the bandwidth frequency is not specified, but allowed to vary with system performance. An example of the Neal-Smith criterion plot can be see in Figure 6.6.

6.3.3 Bandwidth

The bandwidth criterion is an evolution of the Neal-Smith criterion.¹¹⁶ In the bandwidth criterion, the minimum closed loop pitch attitude tracking bandwidth is not specified, unlike Neal-Smith where it is specified at 3.5 rad/sec . Allowing bandwidth to vary gives broader application of the

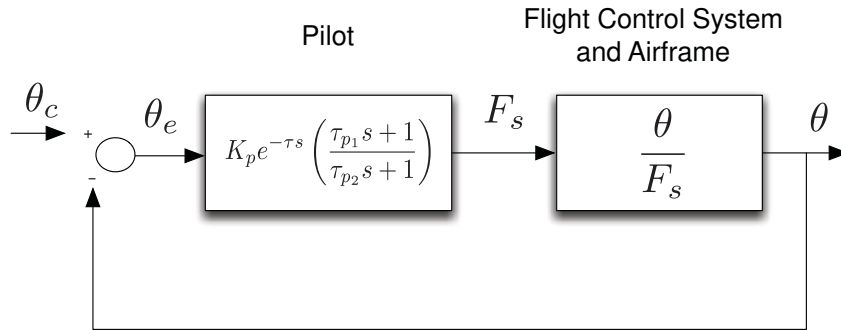

Figure 6.5: Pilot model used with Neal-Smith criterion.^{26, 104, 112}

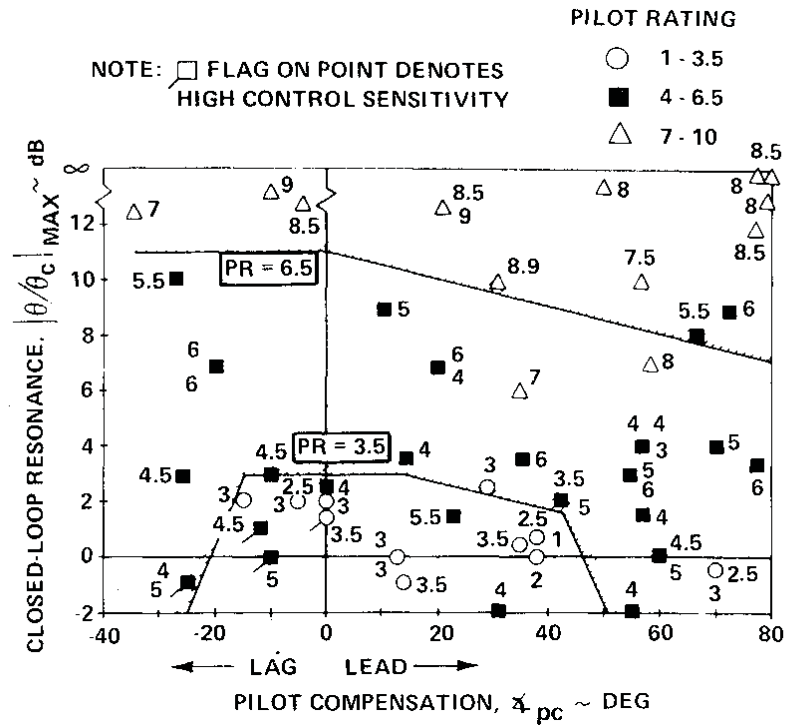

Figure 6.6: Neal-Smith criterion for use in piloted aircraft with sample data.^{26, 104, 112}

criterion to aircraft of different sizes, so that a nimble fighter may have a higher bandwidth, or lumbering cargo aircraft may have a smaller bandwidth. The criterion is frequency based, and defines the bandwidth as the maximum frequency at which the phase margin is at least 45° and the gain margin is at least 6 dB. Using these parameters as a metric allows the pilot to double his gain or adjust time delay without causing an instability in aircraft control. While the criterion was developed specifically for the pitch attitude control loop, it can be applied to any system control loop. A summary of the criterion is given by Hoh, et al. :⁹³

“It follows that airplanes capable of operating at large values of bandwidth will have superior performance when regulating against disturbances. When flying an aircraft with low bandwidth, the pilot finds that attempts to rapidly minimize tracking errors result in unwanted oscillations. He is, therefore, forced to ‘back off’ and accept somewhat less performance (larger and more sustained tracking errors). It is not difficult to imagine a clear cut preference on the part of pilots for aircraft with increased bandwidth capabilities.”

Hoh et al. further claim that “Most, if not all, familiar handling quality metrics are, in fact, a measure of bandwidth.”⁹³ This criterion, along with most others first rely on the low order equivalent system reduction of a higher order system to a short period approximation^{88,93} represented as

$$\frac{\theta}{\delta_e} = \frac{M_{\delta_e} \left(s + \frac{1}{T_{\theta_2}} \right)}{s \left(s^2 + 2\zeta_{sp}\omega_{sp}s + \omega_{sp}^2 \right)} \quad (6.21)$$

The pilot is then modeled as an idealized system

$$\frac{\delta}{\theta_e} = K_p e^{-\tau_e s} \quad (6.22)$$

capturing a simple time delay for pilot response, and a gain from pilot input. The full closed loop system including pilot compensation can then be modeled as Figure 6.7. By increasing pilot gain,

the system poles can be moved until reaching the bandwidth frequency (ω_{BW}) as seen in Figure 6.8. Using a Bode plot, the value of the bandwidth frequency can be found. The methodology for finding the bandwidth frequency is as follows, and references Figure 7.5. The phase bandwidth frequency ($\omega_{bw_{phase}}$) is the frequency at which the phase is 45° above the 180° crossing on the phase plot. The gain bandwidth frequency ($\omega_{bw_{gain}}$) is the frequency at which the gain is 6 dB above the value found at the 180° crossing frequency (ω_{180}). The bandwidth frequency ω_{bw} is then the lesser of either $\omega_{bw_{gain}}$ or $\omega_{bw_{phase}}$. If $\omega_{bw} = \omega_{bw_{gain}}$ the system is said to be gain margin limited, and if $\omega_{bw} = \omega_{bw_{phase}}$ the system is said to be phase margin limited.

The shape of the phase curve above ω_{bw} is also used in this criterion. It is used to measure time delay, since rapid roll offs in time delay can be represented as pure time delay. The change in phase due to time delay is linear in frequency, and can be approximated as

$$\tau_e \approx \tau_p = -\frac{\phi_1 + 180^\circ}{57.3\omega_1} \quad (6.23)$$

where ω_1 is a frequency above the neutral stability frequency and τ_p is the approximation to τ_e . The criterion was originally expressed as Figure 6.10. In later application, this criterion has been used to predict PIO (Pilot Induced Oscillation, also referred to as APC, Aircraft Pilot Coupling). In further study by Mitchell and Klyde¹¹⁷ “the pitch attitude bandwidth limits in MIL-STD-1797 have been found to be too stringent and have been significantly adjusted.” The new boundaries are presented in Figure 6.11

Shortcomings to this approach have been highlighted by Hodgkinson et al.²⁹ where a shelf like frequency response can cause small pilot gain changes to cause large changes in bandwidth frequency. Hodgkinson et al. suggest using a Nichols chart to represent the short period transfer function. This method, while applicable is not as widely used as the original Bode plot form. This criterion has been primarily applied to the short period mode of aircraft, but has also seen application to flight path angle control as well as roll axis control. While the PIO boundaries to the bandwidth criterion do not apply to UAV applications, the concept of finding the system’s maximum “bandwidth

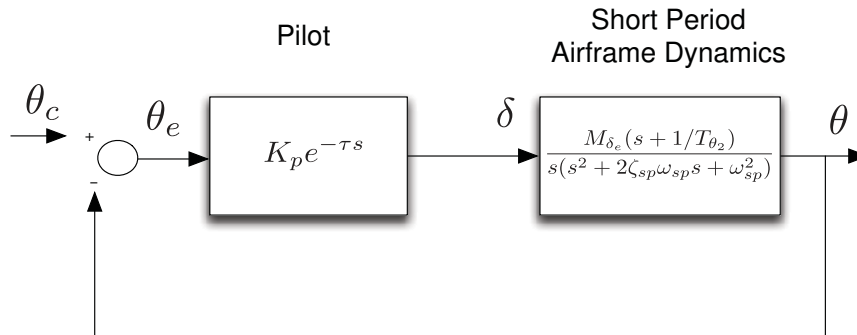

Figure 6.7: Bandwidth longitudinal control block diagram.⁹³

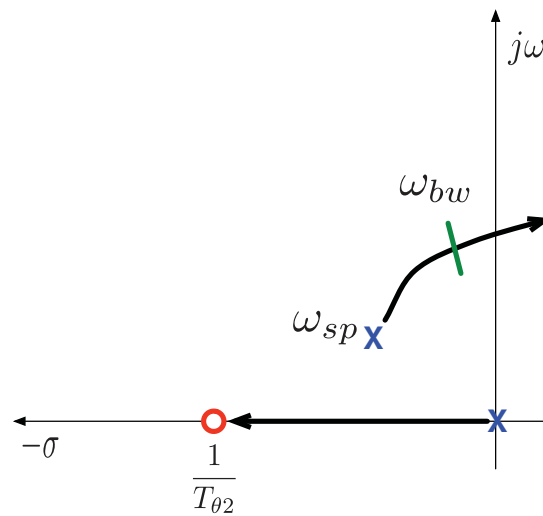

Figure 6.8: Root locus longitudinal control diagram with bandwidth frequency.⁹³

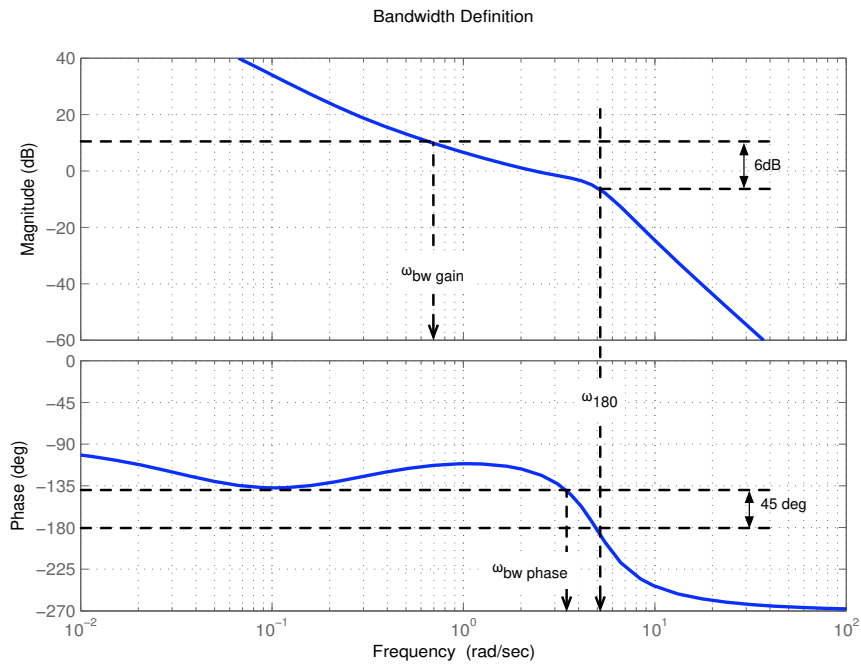

Figure 6.9: Definition of bandwidth frequency, ω_{BW} .⁹³

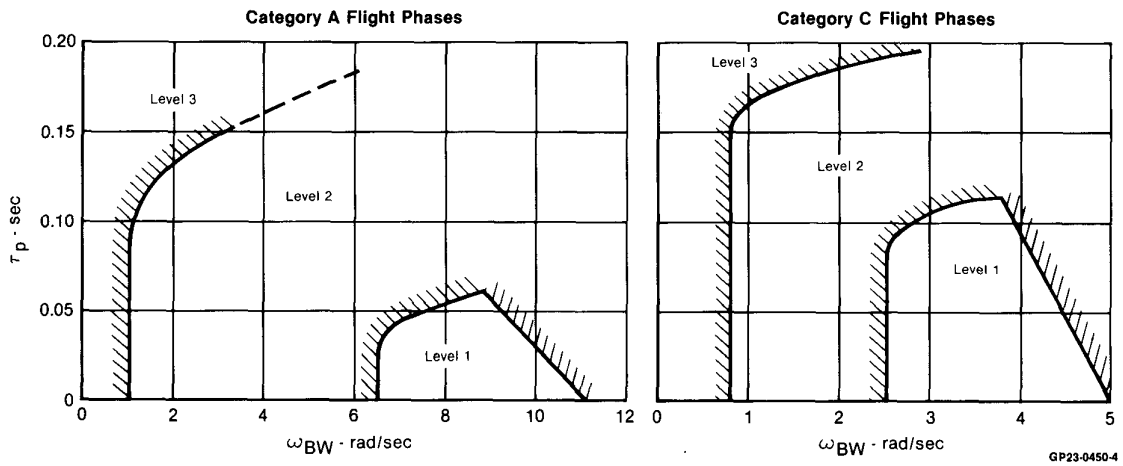

Figure 6.10: Bandwidth requirements from MIL Handbook,²²

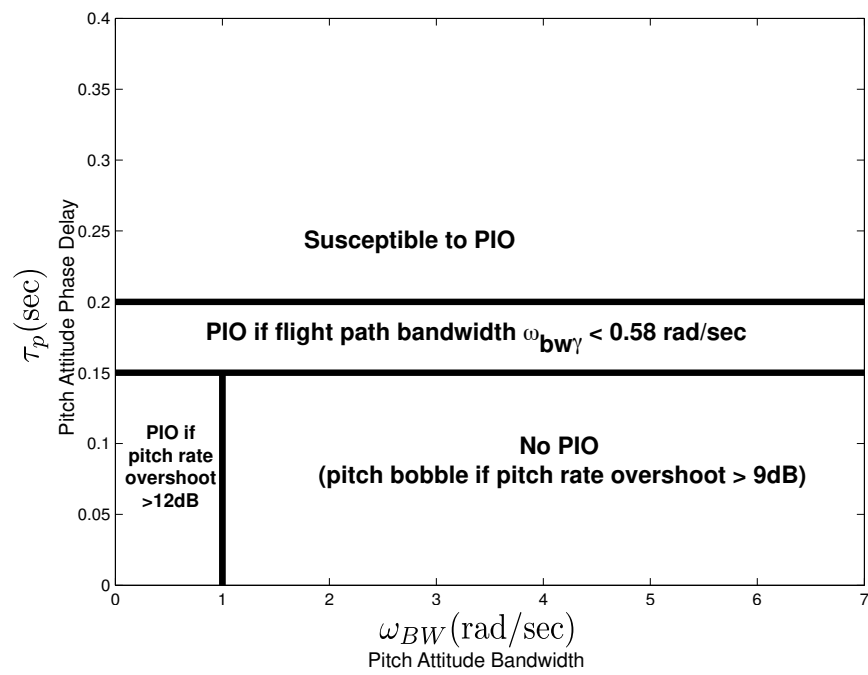

Figure 6.11: Revised bandwidth requirements to aid in PIO prediction.^{117,118}

frequency” to gauge system performance does hold some merit for UAV applications, specifically when the system is judged in relation to the bandwidth of a sensor and fulfilling mission requirements where both systems must work in concert. By specifying a minimum total aircraft/sensor system bandwidth this criterion could be used to ensure proper performance for a desired mission. The applicability of this criterion to other modes beside the short period, and to any response type makes this criterion particularly attractive.

6.3.4 Time Domain Methods

The time domain criterion discussed in MIL-STD-1797 by Gibson¹¹⁹ was originally defined in AGARD-CP-333 and ICAS-86-5.3.4. This criterion uses dropback as a means to quantify acceptable pitch response in the time domain. The time domain criterion does not necessarily break categories into level one, two, or three, but does provide guidance for short period time response. The criterion gives guidance to classical response of a short period, but does not give correlation to higher order systems where control systems may be involved to control the aircraft. MIL-STD-1797 states:

“A conclusion to be drawn is that for low-order aircraft with elementary pitch damper augmentation, a low maneuver margin should be aimed for, with its inherently high natural damping, if precision pitch handling is required.”²²

Interestingly Hoh et al. have found that “This criterion has been proven to appear in the bandwidth criterion as well. The upper limit on bandwidth as stated in MIL-STD-1797A has been found to be characterized by the pitch attitude dropback.”¹²⁰ The dropback criterion has traditionally been used to judge pitch attitude and its relationship to flight path angle during the landing task. Dropback is defined as seen in Figure 6.12, and the relationship between pitch attitude and flight path angle can be seen in Figure 6.13. When $A = B$ in Figure 6.12 then an ideal integral response in pitch attitude is achieved. When $A > B$ overshoot may occur, and the pitch response is deemed sluggish. When $A < B$ the vehicle is overly responsive in pitch and dropback at the end of the maneuver will occur.

According to Gibson $A = B$ is ideal, but dropback is preferred to overshoot. The ratio of q_m to steady state pitch rate during the maneuver must be $1.0 \leq q_m/q_{ss} \leq 3.0$.

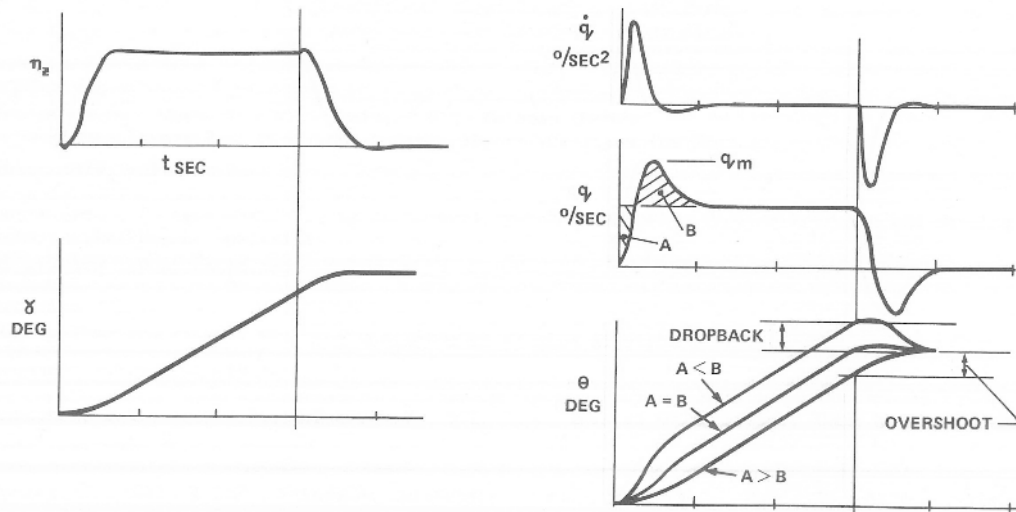

Figure 6.12: Definition of dropback by Gibson.²²

Gibson also investigated criteria to predict PIO, and offered the phase rate criterion as a possible solution. It is similar to the Neal-Smith criterion in that it attempts to measure required phase compensation by a pilot during a maneuver. While others have shown applicability of this criterion to remotely piloted vehicles (RPVs),¹¹⁶ its applicability to UAVs is limited, since its boundaries and metrics relate specifically to a human's ability to compensate for a deficient control system.

6.4 SAE94900

The primary scope of SAE94900 (formerly MIL-F-9490D) is to “establish general performance, design, test, development and quality assurance requirements for the Flight Control Systems of military piloted aircraft.”¹⁰⁵ This document does not necessarily give criteria that may be useful in specifying the dynamic response of aircraft, but it does lend guidance to the specification of the control systems that determine the dynamic response of modern, augmented aircraft. Significant

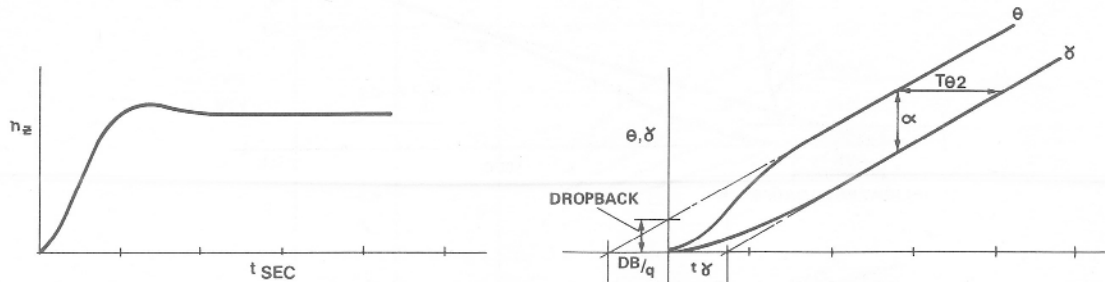

Figure 6.13: Relation of flight path angle and pitch attitude as shown by Gibson.²²

Mode Frequency (Hz)	Airspeed			
	Below V_{0min}	V_{0min} to V_{0max}	At Limit Airspeed (V_i)	At $1.15 (V_i)$
$f_m < 0.06$	GM = 6 dB, no phase requirement	GM = ± 4.5 dB PM = $\pm 30^\circ$	GM = ± 4.5 dB PM = $\pm 20^\circ$	GM = 0 PM = 0°
$0.06 \leq f_m$ First Elastic Mode	GM = 6 dB, no phase requirement	GM = ± 6.0 dB PM = $\pm 45^\circ$	GM = ± 4.5 dB PM = $\pm 30^\circ$	GM = 0 PM = 0°
$f_m > \text{First}$ Elastic Mode	GM = 6 dB, no phase requirement	GM = ± 8.0 dB PM = $\pm 60^\circ$	GM = ± 6.0 dB PM = $\pm 45^\circ$	GM = 0 PM = 0°

Table 6.1: Gain and phase margin requirements as defined in AS94900.¹⁰⁵

portions of this document specify the safety and reliability of components of a flight control system, which are out of scope for this study. The document does, however list robustness requirements for flight control systems stating gain and phase margin requirements for piloted aircraft during aerodynamic closed loop operation. The gain and phase margin requirements are listed in Table 6.1.

AS94900 also describes intensity exceedance probability, for gusts and turbulence, referencing MIL-STD-1797 for specific turbulence requirements. These turbulence values place basic robustness requirements on a flight vehicle. Another criterion that is listed in AS94900 that ties directly to turbulence relates to ride smoothing. Specifically Section 3.2.4.2.8.1 describes the ride discomfort index as

$$D_i = \left[\int_{0.1}^{f_t} |w(f)|^2 |T_{CS}(f)|^2 \phi_u(f) df \right]^{1/2} \quad (6.24)$$

Ride Discomfort Index	Probability of Exceedance	
0.7	0.20	vertical
0.28	0.01	lateral

Table 6.2: Probability of exceedance of ride discomfort indices (vertical and lateral) in AS94900.¹⁰⁵

where a lower index D_i denotes a more comfortable ride. The acceleration weighting function $w(f)$ is shown as Figure 6.14. T_{cs} is the transmissibility of the disturbance at the crew station, and $\phi_u(f)$ is the Von Karmen gust power spectral density of intensity specified in MIL-STD-1797.

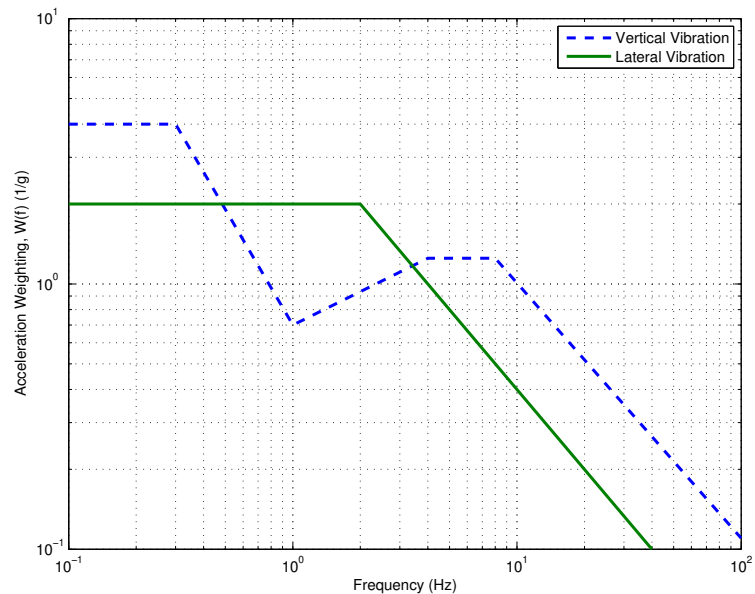

Figure 6.14: Definition of acceleration weighting function $w(f)$.¹⁰⁵

To ensure adequate ride smoothing AS94900 requires a probability of exceedance as seen in Table 6.2. This criterion was originally created to reduce crew fatigue, especially during long missions in large aircraft, such as bombers, where crew would be stationed at various points in the aircraft's fuselage.^{121–123} While UAVs will not have human crew aboard the vehicle, the sensors that the UAV carries will require ride conditioning to ensure proper operation. The ride quality index can be

modified to give a measure of frequency vibration imparted to a sensor onboard an aircraft based on a predicted gust load. While this may not be directly seen as “flying qualities,” modification to this criterion may give design guidance to gust rejection requirements for a vehicle that will become a part of the vehicle’s flying qualities.

6.5 NASA TN D-5153

This document is the primary reference for the “Cooper-Harper” pilot rating scale.²³ Later revisited in a Wright Brother’s Lectureship in Aeronautics by Harper and Cooper,²⁴ it creates a rating scale that can be used by a pilot to judge an aircraft’s ability to perform a given task. As important as providing an accurate rating, the task itself is key in judging the pilot/aircraft system. Along with the numerical rating, pilot comments are required to give justification to the rating. Often pilot comments are just as, if not more informative than the rating number given. Beyond giving a standard scale to judge aircraft handling qualities, it serves as an aid to probe for deficiencies in aircraft handling qualities. An example of the Cooper Harper rating scale can be seen in Figure 6.15. While this document was written specifically to give human aircraft operators a way to quantify data that was purely qualitative, it can still remain applicable to UAVs so long as the tasks are appropriately defined. The Cooper Harper scale could be used to judge a vehicle’s mission effectiveness in relation to an operator’s ability to perform a given task with a sensor package, or an operator’s ability to launch or recover a vehicle.

6.6 ADS-33E-PRF

The scope of ADS-33-PRF states that “This specification contains the requirements for the flying and ground handling qualities of rotorcraft.”¹⁰⁶ While the targeted aircraft of this document is rotorcraft, there are lessons to be learned from this document from the process used in defining flying qualities requirements. These lessons can be used in creating a UAV flying qualities criteria. Unlike MIL-STD-1797 that contains multiple criteria for short period flying qualities with no guidance

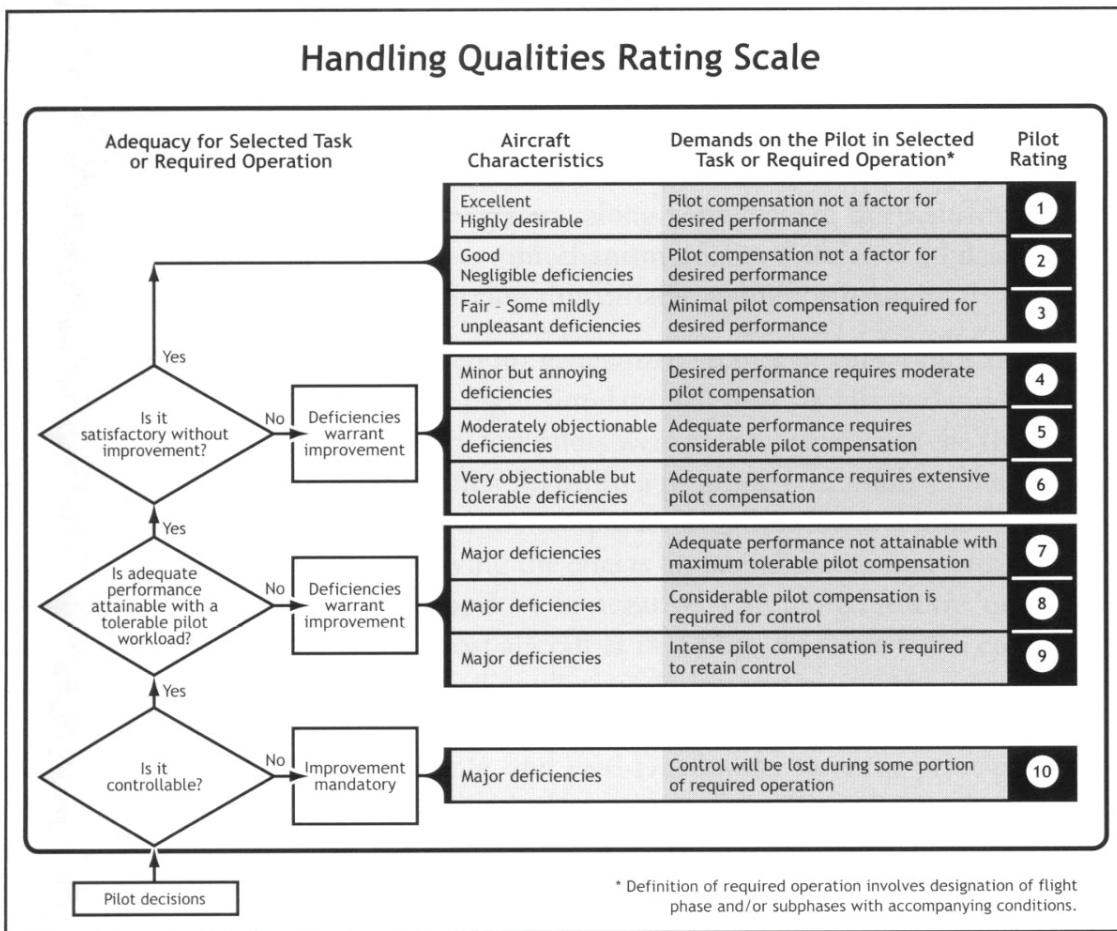

Figure 6.15: Cooper Harper rating scale.²³
(NASA, TN D-5153, fair use.)

as to when one may be more appropriate in a given situation, ADS-33E-PRF specifies only one criterion. The philosophy used in ADS-33E-PRF owes its heritage to technical report written by Mitchell et al.¹²⁴ suggesting revisions to MIL-STD-1797a. The document specifies mission task elements that are to be used in aircraft design and evaluation. The mission task elements then rate different tasks in terms of task aggressiveness and precision. The task elements are broken down “to allow for different standards of precision and aggressiveness” following recommendations from WL-TR-94-3162.¹²⁴ Specifically, Table 1 in ADS-33-E-PRF lists specific mission task elements that must be satisfied for compliance. The performance standards for each task can then be tailored based on different levels of desired precision and aggressiveness. Unlike other documents reviewed for this study, ADS-33-PRF uses a system engineering approach to defining requirements for the aircraft’s performance. This is accomplished by first defining mission tasks that are to be preformed by the aircraft, and then specifying performance requirements to verify that requirements are met for those mission tasks, and then finally giving flight test maneuvers that can be used to validate the vehicle’s ability to perform the desired mission tasks.

6.7 Conclusion

Piloted flying qualities criteria were first created to categorize and then standardize aircraft. Later flying qualities criteria were created to respond to the growing changes in aircraft flight control technology. As more complex aircraft emerged, different techniques were employed to analyze and predict vehicle-pilot interaction and performance. As newer technologies such as nonlinear control and unmanned aircraft continue the evolution of aircraft flying qualities criteria must also evolve to address these new technologies. By basing new criteria on techniques historically accepted, a sense of comfort and intuition that has been fostered in the aviation community can be leveraged to introduce newer standards. The concepts underpinning criteria such as bandwidth, the Cooper-Harper rating scale, mission task elements, and metrics similar to the ride discomfort index can be transitioned forward in the creation of new criteria. The systems approach taken in ADS-33E-PRF is

especially attractive in creating a mission based criterion for UAV use. Taking the knowledge from this chapter, the next two chapters look to apply some of the concepts outlined in this chapter to nonlinear control systems and to UAVs. Chapter 7 proposes new flying qualities criteria for UAVs, and Chapter 8 details a study to use the Cooper-Harper rating scale to rate a pitch tracking task with an adaptive controller.

UAV Flying Qualities

THE application of flying qualities analysis to UAVs presents a unique problem. Since flying qualities analysis traditionally focuses on pilot opinion, a major component of flying qualities analysis must be rethought. There is however, a large body of work of piloted criteria that does provide guidance for the application of flying qualities analysis to UAVs. Any application of a criterion to UAVs must follow some of the basic tenants used in piloted analysis. It must be simple enough to use, effective enough to make worth using, and familiar enough to users so that there is a feeling of intuitive comfort in using it. Taking this guidance a methodology is described in this chapter that can be used to specify UAV flying qualities requirements.

7.1 UAV Criteria Guidance

Based on documents reviewed in chapter 5 and chapter 6, guidance is offered in the effort to creating a flying qualities criterion for UAVs. Realizing the extensive work that has been done in the aviation community to create flying qualities specifications for piloted aircraft, this section provides an outline to be used to create a new UAV flying qualities criterion.

7.1.1 Classification of Aircraft

Traditional flying qualities methods break their specifications into different aircraft classifications and flight phase categories. The manned aircraft classification as specified in MIL-F-8785C can be found in Table 5.1 of in Section 5.1.1.

The classes are primarily delineated by gross weight and limiting load factor. This is “because they are considered to be gages of the maneuvering capability of an airplane and they reflect the mission for which it will be used.”¹⁸ In an effort to create aircraft classes that mimic the utility of manned aircraft categories a proposed classification for UAVs is proposed in Figure 5.8 of Section 5.2.2. Chapter 5 highlights the need for UAV classification, as well as the methodologies chosen for the classes created.

7.1.2 Categorization of Flight Phases and Aircraft Maneuvers

Just as manned aircraft have been traditionally categorized by standards used in MIL-F-8785C, the flight phase categories as defined by MIL-F-8785C are still used as today’s standards. These categories were introduced in Table 5.2 of Section 5.1.1, and are not fully expanded as defined in MIL-F-8785C in Table 7.1. These categories are based on manned aircraft that were developed in the 1950’s. Mitchell et al. proposed changes to these categories as well as how flying qualities standards are included in the design process by incorporating mission-oriented tasks.¹²⁴ Mitchell et al. give the following reasoning for breaking the traditional three flight phase categories into four categories:

“Category A is too broad, ranging from air-to-air combat to reconnaissance.”

“Category B is too lenient and should apply only to flight in Visual Meteorological Conditions (VMC).”

“Category C is not sufficiently stringent for the precision landing typically preformed in flight research, and Category A is too stringent for that MTE (Mission Task Element).”

Instead Mitchell et al.¹²⁴ suggest dividing flight phase categories into four categories, based on precision of the task and aggressiveness required to accomplish the task. An example of how these new categories relate to the previous categories defined in MIL-F-8785C can be found in Figure 7.1. Mission tasks that a given aircraft would be required to perform would then be divided into one of the four new categories. These mission tasks were called mission task elements (MTEs), and they would be chosen from a catalogue of predetermined tasks. A proposed breakdown for these MTEs is given as in Table 7.2. Specific flight test maneuvers for standard test evaluation maneuver sets (STEMS) are also given¹²⁵ as a method for validating the flying qualities requirements. The STEMS would be chosen to verify that the MTE requirements had been implemented correctly. Following this structured systems engineering approach, ADS-33-PRF implemented this methodology.¹²⁰

In order to establish a UAV flying qualities criterion, UAVs should follow the same four categories presented by Mitchell et al.,¹²⁴ and implemented in ADS-33-PRF. Each of these new categories would have MTEs prescribed to them, an example of which would be Table 7.2. Using Figure 7.3 as an example, aircraft with different roles would be assigned MTEs that would only be relevant to that role. As roles in the UAV force change and evolve, a basic pool of MTEs would remain relatively static, allowing different combinations of MTEs for any new or changing aircraft role. These MTEs would then be assigned a MTE category of A, B, C, or D, determined by the MTE's required combination of precision and aggression, following those previously shown in Figure 7.1. The MTE categories would then contain requirements for the UAV flying qualities criterion. Using this method ensures that only four sets of requirements would be created for the flying qualities criterion, and would be relevant across UAV classifications. The MTEs would also be linked to flight test elements as shown in Figure 7.2. This would allow vehicle requirements to flow down to vehicle design and analysis as well as verification of the vehicle requirements based on MTEs. Unlike criteria based on flight phase categories in Table 7.1, the criteria could specify compliance to a desired set of maneuvers linked to a MTE category as opposed to a general maneuver category.

Category A	Nonterminal flight phases that require rapid maneuvering, precise tracking, or precise flight path control.
	Air to air combat (CO) Ground Attack (GA) Weapon delivery/launch (WD) Aerial recovery (AR) Reconnaissance (RC) In-flight refueling (receiver) (RR) Terrain following (TF) Antisubmarine search (AS) Close formation flying (FF)
Category B	Nonterminal flight phases that are accomplished with gradual maneuvers and without precision tracking, although accurate flight path control may be required.
	Climb (CL) Cruise (CR) Loiter (LO) In-flight refueling (tanker) (RT) Descent (D) Emergency descent (ED) Emergency deceleration (DE) Aerial delivery (AD)
Category C	Terminal flight phases are normally accomplished using gradual maneuvers and usually require accurate flight-path control.
	Takeoff (TO) Catapult takeoff (CT) Approach (PA) Wave-off/go-around (WO) Landing (L)

Table 7.1: Flight Phases as defined in MIL-F-8785C.

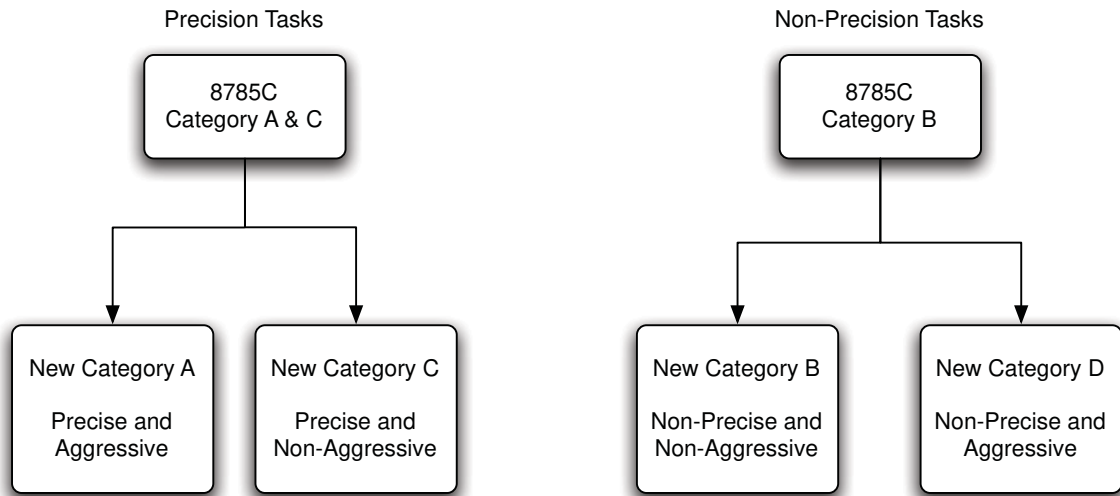

Figure 7.1: Proposed categories.¹²⁴

Non-Precision Tasks		Precision Tasks	
Non-Aggressive Category B	Aggressive Category D	Non-Aggressive Category C	Aggressive Category A
Reconnaissance	Gross Acquisition	Aerial Recovery	Tracking a Moving Target
In-flight Refueling (tanker)	Max g turn	In-flight Refueling (receiver)	Ground Attack
Takeoff	Anti-Submarine	Precision Landing	Terrain Following
Non-precision Landing	Split-S, Loop, etc.	Formation Flight	Precision Aerobatics

Table 7.2: Example maneuvers for proposed categories.¹²⁴

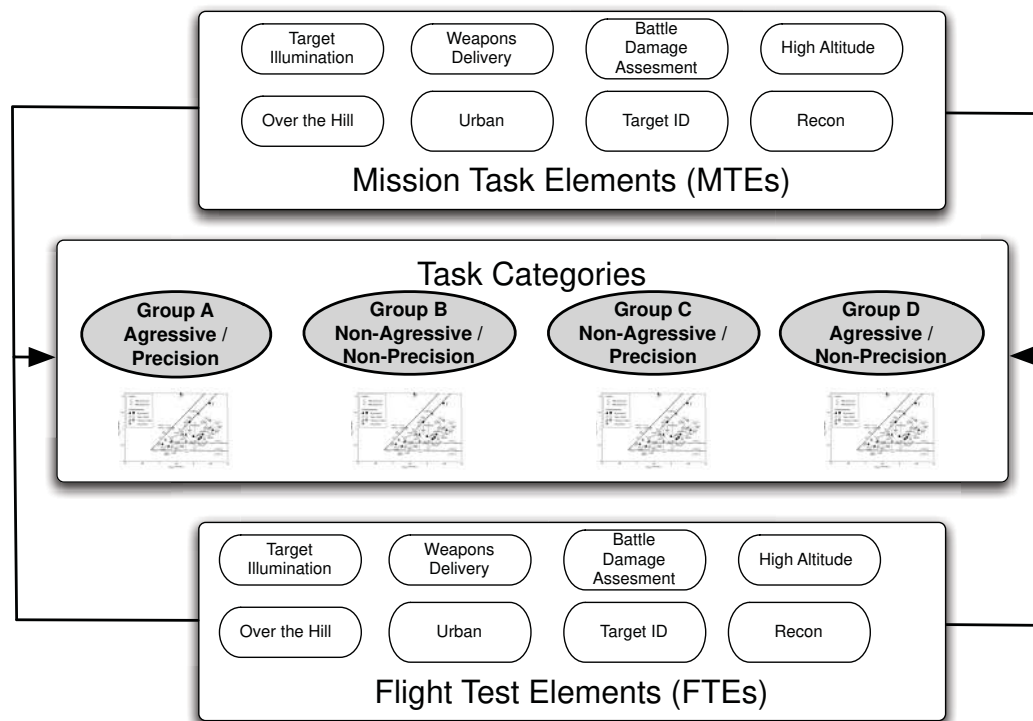

Figure 7.2: Flying qualities cycle

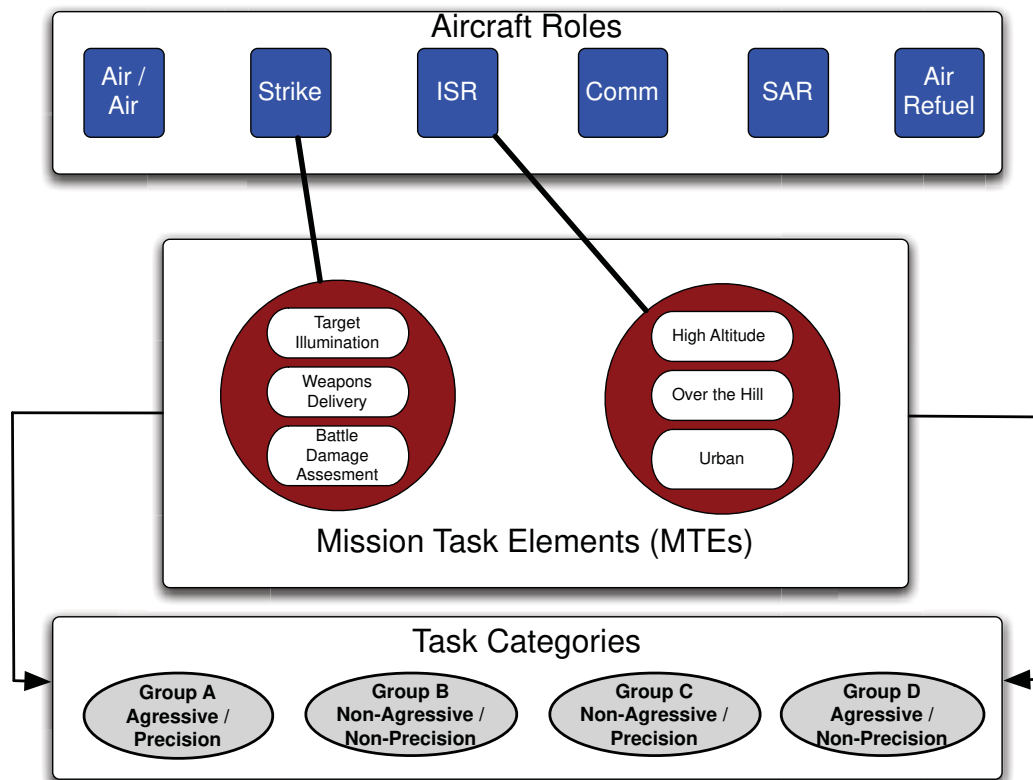

Figure 7.3: Mission task elements

7.1.3 Evaluation of UAV Task Performance

The evaluation of the sensor/aircraft system performance of a task must be done on a scale that can be applicable across tasks. While predicted performance analysis can be used to measure compliance with design requirements and specifications listed in the flying qualities criteria, a scale used to measure flight test performance to aid in validation testing is also required. The Cooper Harper scale as seen in Figure 6.15 has traditionally been used in piloted aircraft to perform this function. The Cooper Harper scale can be modified as seen in Figure 7.4 to become a task generic scale for UAVs. Just as in piloted evaluation, the task description and comments by the UAV operator will be key in using the scale to properly evaluate the sensor/aircraft system. Using this new rating scale the UAV and the sensor system can be evaluated as an integrated system against mission performance. This rating scale also includes the ability to check an autonomous UAV against disturbances so that the system can be evaluated in a relevant operating environment. The ratings of 7, 8, and 9 are dependent only on the UAV without the sensor, and could be used to aid in establishing airworthiness independent of the integrated sensor system. Just as in piloted evaluations adequate and desired criteria would be established, and would be key to the evaluation of the task with the rating scale. Disturbance levels would also have to be included with the adequate and desired criteria for a given task in order evaluate mission effectiveness. The “Results of a System to a Given Task” column replace the “Demands on a Pilot in Selected Task or Required Operation” in the Figure 6.15. By starting at the bottom left of the chart, and then systematically working through the decision tree a UAV operator can provide feedback from a task evaluation in structured manner.

7.1.4 Applicable Manned Flying Qualities Criteria

The flying qualities criteria reviewed in this report make an import assumption in their analysis. They all assume that a pilot is operating the aircraft. While that is a valid assumption for their intended purpose, it is not for the application of flying qualities criteria to autonomous UAVs. The question then remains if any of the criteria are still applicable if this assumption is violated. The answer is a qualified yes.

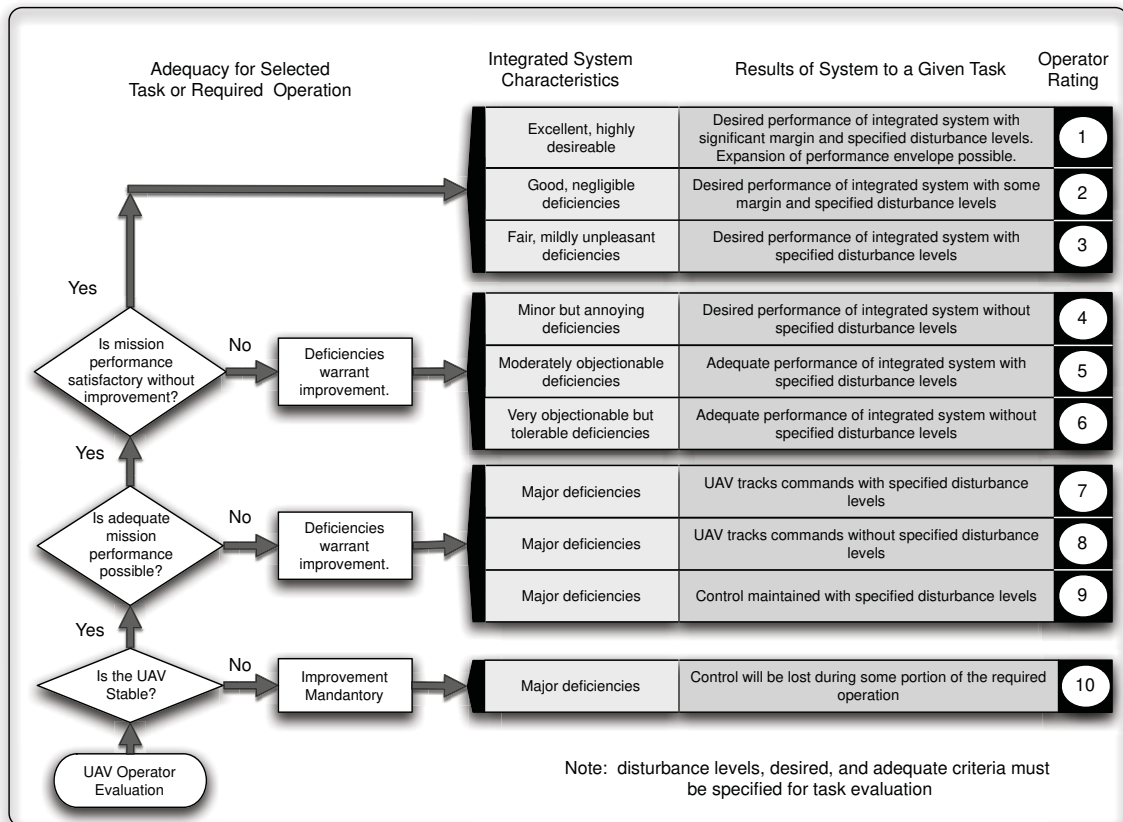

Figure 7.4: A modified form of the Cooper Harper scale for use in sensor/UAV evaluation.

The CAP criterion from MIL-F-8785C also assumes that a control system with significant time lags is not present. While some UAVs may rely on bare airframe dynamics instead of a control system to augment stability, it is not realistic to assume that this will be the normal case with a fully autonomous UAV. For fully autonomous UAVs, one of the criteria that take into account higher order systems is a more obvious choice. The structure of MIL-STD-1797, and later MIL-HDBK-1797 present several options for flying qualities criteria with narratives explaining each method without giving clear guidance as to when to apply a given criterion. This has led to confusion in their application, and contracting issues between government oversight and contractor analysts. Alternatively the methodology chosen by ADS-33-PRF, where one criterion that can be broadly applied, limits confusion and ensures a lack of ambiguity in application.

All the criteria reviewed in MIL-HDBK-1979 model the human pilot as a transfer function that augments the flight of the vehicle. These criteria then place bounds on the aircraft's response based on the human operator's limitations. The question then remains; if all of these criteria were chosen to define the human aircraft interface, are any of them suitable for use in an autonomous UAV? Several of these criteria also attempt to predict a PIO. Can a PIO occur without a pilot?

In the case of large scale UAVs that would require integration into the NAS (National Air Space) following manned requirements for unmanned aircraft does make some intuitive sense, since the UAV would be required to interface with standards currently set for piloted aircraft. The same argument can be made for UAVs that are required to take off and land from ships in a similar manner to piloted aircraft, or make use of standard runways. The target of developing a UAV flying qualities criterion should then be for aircraft that are not intended to interface directly with NAS operational requirements. Aircraft that are capable of operating in the NAS could still fall under UAV flying qualities criteria if they are required to operate in a manner that would exceed manned flying qualities boundaries.

As chosen in ADS-33-PRF, the bandwidth criterion is recommended to serve as the basis for the UAV flying qualities criterion. Choosing one criterion would aid in reducing the current confusion of knowing when to apply a given criterion as is currently the case in MIL-HDBK-1797. The bandwidth criterion does incorporate several of the flying qualities criteria found in MIL-HDBK-1797, and has the added benefit of predicting PIO,¹²⁰ or in the case of an UAV a limit cycle oscillation driven by a control system. Another advantage to the bandwidth criterion is its independence from vehicle response type, whether it be conventional, rate command attitude hold, or attitude command attitude hold. In the case of an UAV the response types may become even more varied, and this criterion would allow for those variations. The criteria also lends itself to application outside of the short period mode, giving it further reason to be used in application to UAVs where modal frequencies may not necessarily be easily separated.

The pilot model of the bandwidth criterion is no longer applicable to UAVs. The boundaries set by that criterion are based on a human operator's ability to control the aircraft. The pilot model would need to be replaced by a sensor model, where the ultimate goal is no longer to fly the aircraft to a given task, but to keep a sensor pointed at a given position. The sensor's dynamics now become a major part of the overall system's ability to perform a MTE, and the sensor/airframe integration becomes the key piece to ensure a MTE is successfully accomplished. In the event that the sensor dynamics can be modeled as a simple gain and time delay a model similar to the one used in Figure 6.7 could be potentially used. The criterion would then require that the total system bandwidth be greater than a bandwidth specified to complete a given task. This would allow the total system bandwidth to be large enough to achieve the goal of keeping the sensor pointed at the desired location.

The ride quality index found in SAE94900 also holds promise for use in integrating the UAV and sensor package into a complete system. The ride quality index as currently constituted is used

to measure the fatigue of a human subject in an aircraft when exposed to long term vibration. By calculating the transferred inputs from the turbulence to the place of the aircraft where the sensor is located, vibration input to the sensor can be estimated. These vibration inputs can be used to determine if sensor stabilization is required for a given airframe, or if current sensor vibration requirements are adequate. Incorporating this criterion into UAV development would aid in the sensor/UAV system integration to ensure proper operation during encountered turbulence.

7.2 Forming a New Criterion

A new criterion must be simple enough to use, effective enough to make worth using, and familiar enough to users so that there is a feeling of intuitive comfort in using it. When piloted flying qualities criteria were reviewed for possible use in UAVs it became apparent that no one criteria was going to be able to be used without modification. Linear systems theory was chosen as an analysis means in creating a UAV criterion in order to align with currently accepted piloted flying qualities criteria. The bandwidth criterion was chosen as a starting point while also paying attention to suggested modifications to current standards in order to provide an updated and relevant method for evaluating UAVs.

7.2.1 Frameworks

The approach taken to application of the criteria is similar to that used in ADS-33-PRF.¹⁰⁶ While this standard was written for rotorcraft, the systems engineering approach it takes to requirements specification is more attractive than MIL-STD-1797B.¹²⁶ The basic precept used in ADS-33-PRF is the definition of a mission task element (MTE), and then the application of analysis to the MTE. By breaking down a vehicle's overall mission into specific elements, a basic list of tasks can be defined independent of the total mission of the vehicle. This allows vehicles with varying missions, but overlapping mission task elements to be directly compared. The MTE approach also allows a total mission to be built from a set of standard MTEs. Each MTE would then be given a rating on aggressiveness and precision, ultimately allowing a chart such as the one in Figure 7.3 to be used.

This approach as seen in Figure 7.2 also allows flight test to replace modeling analysis tests where modeling data for a UAV may not be obtainable. Further, flight test can be used to verify analytical results where a combination of modeling and flight test is practical.

The use of linear systems theory has traditionally been very attractive in creating a flying qualities criterion. It is the primary form of analysis used in modern flying qualities analysis, and provides a familiar platform for continued analysis of vehicles. Linear systems theory also allows abstraction of more complex systems and forms a basic, simple framework for complex systems to be modeled. While the simplification process of taking more complex systems and representing them in a linear fashion may introduce modeling inaccuracies, careful application of this technique using LOES has been used for piloted aircraft. Linear systems presents analytical tools that can be readily used that are not available if a nonlinear approach is taken. The goal of creating a new criterion is to make a system that is as simple as possible, but still representative of most implementations of sensors and aircraft, much in the same way that the bandwidth criterion did this for piloted aircraft with feedback control systems. By using linear systems, a block diagram approach can be taken to visually represent the more complex systems that are being analyzed.

7.2.2 Classical Bandwidth Compared to Flying Qualities Bandwidth

The flying qualities criterion for bandwidth uses a definition for bandwidth that is nonstandard outside of the world of flying qualities. The methodology for finding the flying qualities bandwidth frequency is as follows, and references Figure 7.5. The phase bandwidth frequency ($\omega_{bw_{phase}}$) is the frequency at which the phase is 45° above the 180° crossing on the phase plot. The gain bandwidth frequency ($\omega_{bw_{gain}}$) is the frequency at which the gain is 6 dB above the value found at the 180° crossing frequency (ω_{180}). The bandwidth frequency ω_{bw} is then the lesser of either $\omega_{bw_{gain}}$ or $\omega_{bw_{phase}}$. If $\omega_{bw} = \omega_{bw_{gain}}$ the system is said to be gain margin limited, and if $\omega_{bw} = \omega_{bw_{phase}}$ the system is said to be phase margin limited. The classical definition for bandwidth is “the first

frequency where the gain drops below 70.79 percent (-3 dB) of its DC value.”⁹¹ Both definitions for bandwidth are shown in Figure 7.5, and it is apparent that the values for bandwidths can be quite different.

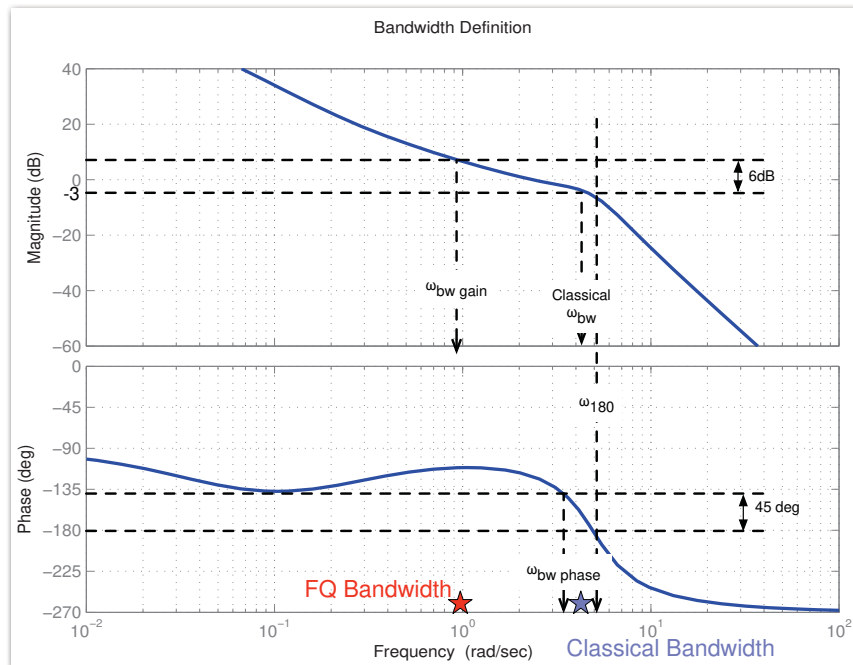

Figure 7.5: Definition of bandwidth frequency, ω_{BW} ⁹³ compared to the classical bandwidth definition.

The question then arises as to which bandwidth definition to use for defining UAV flying qualities definition. Sensor manufacturers will use a classical definition of bandwidth when specifying their capabilities, whereas aircraft have traditionally been specified using the flying qualities bandwidth definition. Both definitions have their advantages and disadvantages for use in specifying a criterion for an integrated aircraft sensor system. Using flying qualities bandwidth UAVs could be compared not only against other UAVs, but also with piloted aircraft. The flying qualities bandwidth is also a more familiar quantity among engineers used to analyzing vehicle flying qualities. The flying qualities bandwidth also has a level of robustness built into its definition, since it requires 6 dB of

gain margin and 45 degrees of phase margin. The use of the classical definition for bandwidth also has its own merits. It yields the most optimistic measure of performance, which would be popular among vendors of systems. It also is the definition that sensor manufacturers will most likely use to describe their sensors, making a comparison between aircraft and sensor bandwidths much easier and intuitive. The flying qualities bandwidth was also defined with the preferences of the human pilot in mind for safely controlling a vehicle. With a human no longer part of the system in an autonomous UAV, this driving factor is less important.

Another factor in using flying qualities bandwidth for piloted systems is that most piloted systems have rapid phase roll offs which can include abrupt loss in stability margin. The rapid phase roll off is often quantified as phase delay, which is similar to equivalent system time delay.¹²⁷ Choosing a flying qualities bandwidth ensures that stability margin is maintained, and that abrupt phase roll off is avoided. In UAV application, the shape of the Bode phase plot may or may not be the same as a piloted aircraft. Only in the case that the phase plot is similar between UAV and piloted aircraft would flying qualities bandwidth would provide insurance from encountering the phase cliff generally found in piloted systems.

The lack of phase and gain margin accounting in the classical bandwidth definition would create an uneven playing field for all UAVs to be measured against piloted aircraft. The issue of comparison between different UAVs is a bit more subtle. Robustness to different wind requirements are specified when a new vehicle is contracted. These requirements are often not similar between different platforms. The use of traditional bandwidth to compare UAVs would only allow a comparison of maximum performance of the platform without a measure of its robustness. Ultimately the question must be answered: is this criterion going to be used to compare UAVs against piloted aircraft, or just UAVs to their sensor payloads to judge integrated system mission performance?

7.2.3 Accommodating MIMO Analysis

The use of linear systems analysis for piloted aircraft has always assumed a SISO (single input, single output) system. This key assumption allows basic transfer function analysis to occur, and gives easy to interpret results when using Bode, Nyquist, and root locus analysis. MIMO (multiple input multiple output) analysis complex has fewer established tools and analysis methods. An integrated UAV and sensor package is a MIMO system. The commands to the aircraft and the sensor create multiple inputs, even if there is a single output for the system. A single output case might be a non-zoom camera whose gimbal can only move in one direction. A camera with a zoom, or a multi axis gimballed camera would then be a multi-output system. A technique to simplify this MIMO system to a SISO system can simplify analysis and cast the criterion in a form that is familiar to the aviation community. Where it is not possible to do SISO analysis, a relevant yet simple metric for MIMO analysis can provide an option for a criterion.

7.3 Proposed Criteria

This section proposes two methods in forming a criterion for UAV longitudinal flying qualities analysis. In both criteria, mission performance is used to determine the flying qualities of the aircraft. By using the MTE concept the flight safety segment of flying qualities must be covered by the airworthiness certification external to these criteria. The use of MTEs in piloted aircraft has received some criticism in prior application because they do not account for the operation of the aircraft between mission tasks. While this is a shortcoming to the MTE method, a holistic approach would be much more complex. UAVs of different sizes and roles often overlap mission tasks, but they rarely overlap operationally outside of their direct use to accomplish a mission objective. An example of this is the MQ-9 Reaper and the ScanEagle which are both used for surveillance, but have very different flight envelopes and takeoff/recovery systems.

The goal of accomplishing a mission objective was kept firmly in view during the derivation of

these criteria. The integrated aircraft and sensor system must perform together to achieve a desired goal to achieve mission success. With this vision the aircraft now becomes a platform for sensor operation. The entire system must be measured first for the sensor's capabilities, and then second for the platform stability the sensor requires to perform its mission. In this light, the aircraft becomes a stabilizing platform for the sensor, and the driving question for the aircraft's design is: how stable must the aircraft be to allow the integrated system to perform its mission?

Two different candidate criteria are proposed below. The first is a simplified system that only considers the short period of the aircraft, and the sensor dynamics. The goal of this simplified pitch criterion is to reduce a MIMO system into a SISO system where traditional analysis tools can be applied. The second candidate criterion embraces the MIMO concept and accounts for turbulence and the coupling between phugoid and short period modes that occur during flight. It departs from traditional criteria by taking an energy methods approach to define a metric to predict mission success.

7.3.1 A Simplified Pitch Criterion

This criterion was patterned after the approach taken with the bandwidth criterion where a pilot was used to close a control loop around the short period mode of the aircraft. In this case a control system is used instead of a pilot to stabilize and control the short period. This system includes an added piece not normally seen in a flying qualities criterion, namely the sensor system model. Using a block diagram modeling approach the goal is to reduce a MIMO system to a SISO system for analysis. The reduced block diagram can then be used to compare relative bandwidths between the aircraft's short period response and the sensor's pitch command and response.

7.3.1.1 Modeling

The model created to approximate the sensor and aircraft system can be found in Figure 7.6, where $\theta_{a/cc}$ is the aircraft pitch attitude command, θ_{cs} is the pitch command to the sensor, and the output

is the system's total target output (pitch attitude towards the desired target, θ_{Target}). A diagram of sign conventions used to define the different angles in this system can be found in Figure 7.9. The transfer function G_{SP} is the aircraft short period and the transfer function G_{sens} is the sensor transfer function, both defined in Figure 7.7(a). The G_{SP} and G_{sens} definitions are made here as nominal definitions, although they could be changed to represent a more complex sensor model. Using a well known identity, closed loop systems can be represented as a transfer function as defined in Figure 7.7(b). Using the closed loop definition in Figure 7.7(b) to reduce Figure 7.6a block diagram can be formed as seen in Figure 7.8, where C_{L_SP} is the closed loop short period and C_{L_sens} is the closed loop sensor model.

7.3.1.2 Algebraic Reduction

The block diagram in Figure 7.8 can be represented algebraically as:

$$\theta_{\text{Target}} = (\theta_{cs} - \theta_{a/cc} C_{L_SP}) C_{L_sens} + \theta_{a/cc} C_{L_SP} \quad (7.1)$$

which can be rearranged as:

$$\theta_{\text{Target}} = \theta_{cs} C_{L_sens} - \theta_{a/cc} C_{L_SP} (C_{L_sens} - 1) \quad (7.2)$$

Using this form of the equation several observations can be made. First, as $C_{L_sens} \rightarrow 1$, $\theta_{\text{Target}} \rightarrow \theta_{cs}$. As the closed loop sensor system approaches an ideal system the aircraft dynamics will be overcome, and the sensor will always track the desired target, no matter the aircraft dynamics. Second, as $C_{L_sens} \rightarrow 0$, or the sensor becomes stationary, the $\theta_{\text{Target}} \rightarrow \theta_{a/cc} C_{L_SP}$, or the dynamic response of the aircraft. If $\theta_{a/cc} = 0$, then θ_{Target} will be only defined by the sensor dynamics since the aircraft dynamics will be commanded to be zero. Finally, two special cases that can be used for analysis can be considered. The first case is when $\theta_{cs} = 0$, the system reduces to the SISO system:

$$\theta_{\text{Target}} = -\theta_{a/cc} C_{L_SP} (C_{L_sens} - 1) \quad (7.3)$$

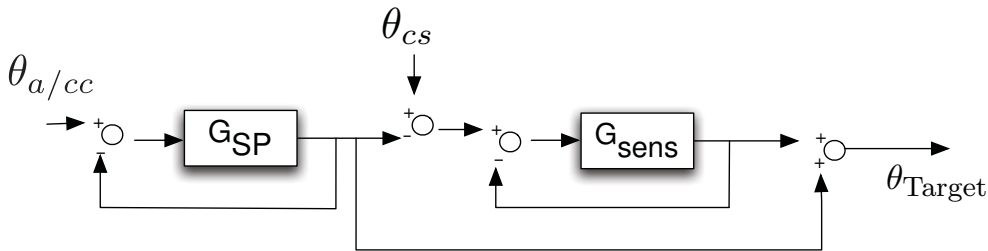

Figure 7.6: Model used to approximate sensor and aircraft system.

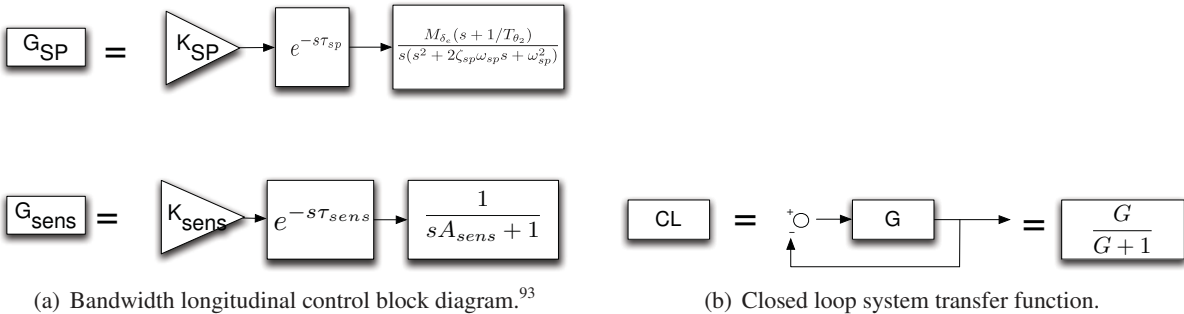

Figure 7.7: Transfer function definitions used to define aircraft and sensor system

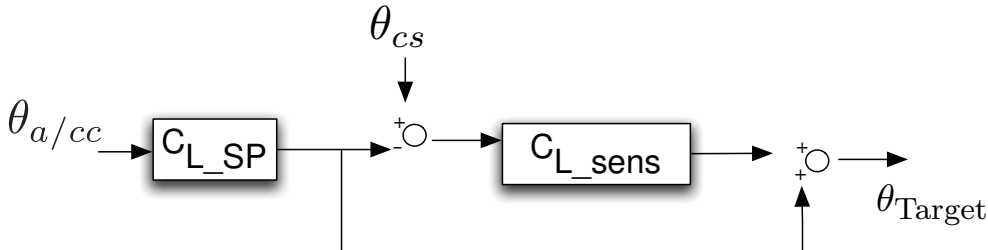

Figure 7.8: Reduced block diagram of sensor and aircraft system.

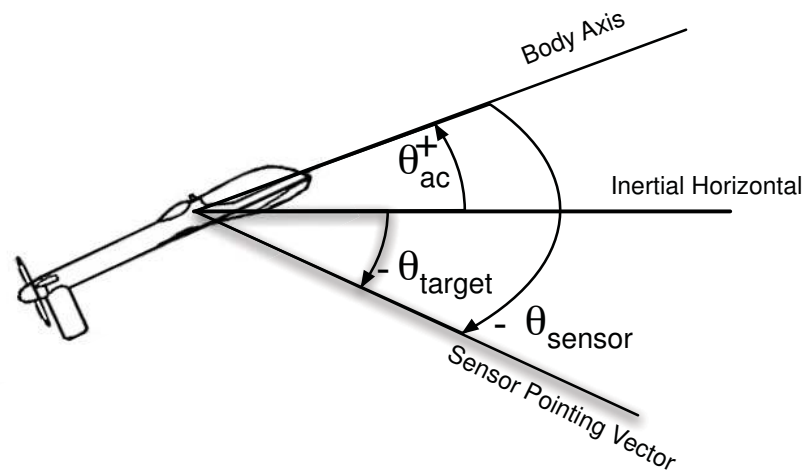

Figure 7.9: Angle descriptions for sensor and aircraft system.

which still involves both the aircraft and sensor dynamic responses. This allows the MIMO system to be analyzed using SISO techniques for a region where θ_{cs} is zero, or near zero. It is important to remember that this analysis is being done in a linear fashion, and the target command is a command away from a steady state condition, and not necessarily from a true zero angle position. The second case that can be used for analysis is where both θ_{cs} and $\theta_{a/cc}$ are nonzero. While this is not a SISO case there are several useful relationships from SISO analysis that can still be used.

7.3.1.3 SISO Analysis Case

With the sensor commanded value set to zero in Equation (7.2) to form the SISO case in Equation (7.3), θ_{Target} should approach zero as well. To overcome the aircraft dynamics C_{L_SP} the sensor dynamics C_{L_sens} must serve to minimize the output. Specifically, as $C_{L_sens} \rightarrow 1$ the output approaches zero. The relationship between C_{L_SP} and C_{L_sens} can be used to pick the proper sensor for a given aircraft by inspecting the Bode plot generated from the system in Equation (7.3).

By finding the peak gain value, and using the relationship for a decibel

$$\text{dB} = 20 \log_{10} \left(\frac{\text{output}}{\text{input}} \right) \quad (7.4)$$

the sensor's ability to reject the aircraft's motion can be analyzed. This becomes a task of specifying the ratio of output to input, where the output is the sensor's pointing error and the input is the disturbance imparted to the aircraft.

As an example of using the SISO case to design a sensor and aircraft system, models for the Virginia Tech SPAARO UAV^{128,129} and a CloudCap[®] TASE gimbaled camera are used to populate Equation (7.3). A Bode plot can be created for this system as seen in Figure 7.10. Using Equation (7.4) the region of the magnitude peak where the magnitude exceeds the desired dynamic response can be defined. This peak region is defined as the "Peak of Disappointment." The region to the right of the peak is the frequency region where the aircraft can not track the desired aircraft command. The boundary line can be chosen based on the aircraft short period response. The area to the left of the peak of disappointment is where the sensor can null the aircraft dynamics. The right boundary of this region is defined by the sensor dynamics. By choosing the right sensor and aircraft system the "Peak of Disappointment" can be shaped such that it does not impact the total system's mission performance. As an example, a time history of the total system can be found in Figure 7.11, and it shows a two degree oscillation of the sensor pointing on the target. Based on mission performance requirements, a decision could be made if this is within acceptable operational limits. As an additional note, Bode plots of the aircraft short period and the sensor can be found in Figure 7.12. The aircraft in this case has a similar phase relationship to the sensor, and the primary influence of the integrated system performance is the gain relationship.

Using data for a Cessna 172¹³⁰ and the same CloudCap[®] TASE gimbaled camera a time history of the output of Equation (7.3) can be generated as found in Figure 7.13. The Bode representation of this system can be found in Figure 7.14. The input to the time history was chosen to be at the

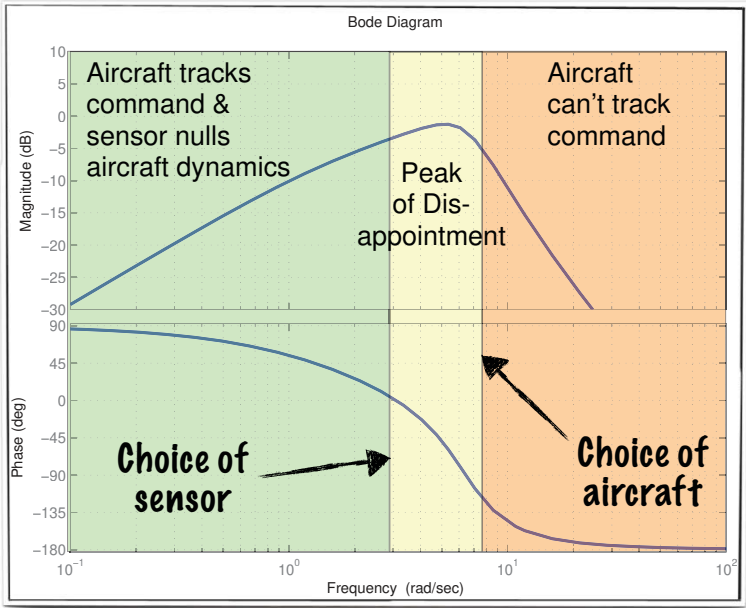

Figure 7.10: Example of analysis of Equation (7.3).

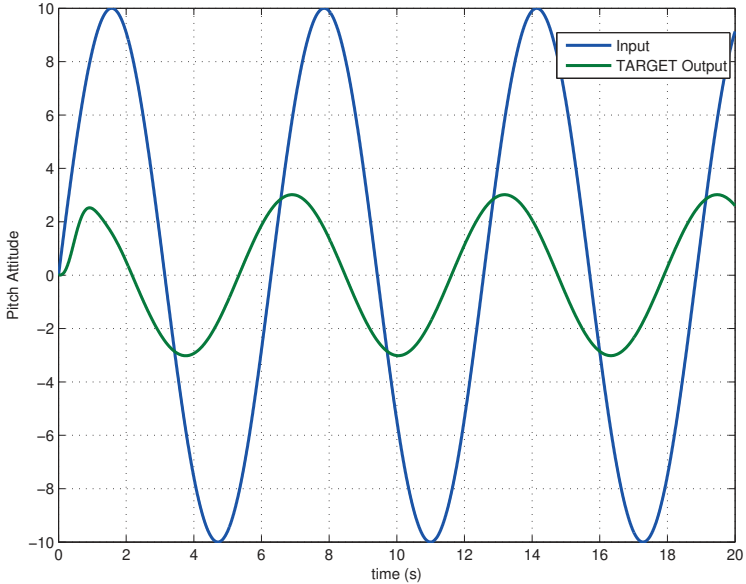

Figure 7.11: Time history of SPAARO short period model and sensor using TARGET SISO model.

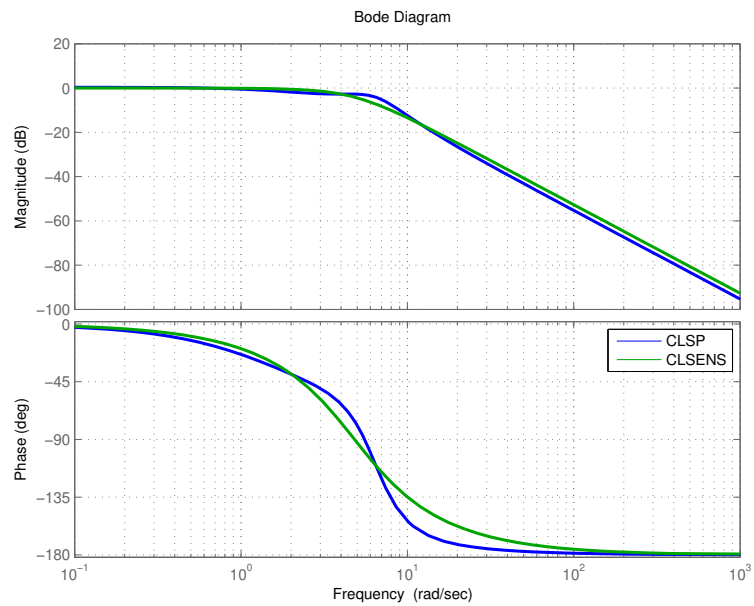

Figure 7.12: Bode plot of individual systems of the SPAARO short period and sensor model.

gain peak frequency found in Figure 7.14(a), the limiting case of this system. A Bode plot of the closed loop transfer functions of both the sensor and the aircraft can be found in Figure 7.14(b). Comparing the two systems in Figure 7.14 can be used as an aid in choosing the proper sensor and aircraft combination to achieve the desired performance in Figure 7.14(a) and Figure 7.13. In the case of piloted aircraft, and especially larger aircraft, the short period Bode plot will reveal that in most cases the vehicle is phase limited, just as in the Cessna 172 case. This is due to the vehicle's high moment of inertia in comparison to smaller UAVs. Phase as well as the gain must be accounted when inspecting the individual systems of the sensor and the aircraft short period.

One way the sensor bandwidth can be changed is by changing the system gain on the sensor. Reducing the sensor bandwidth will reduce overall system performance. Figure 7.15 shows a sensor gain reduction of 1/6 on the sensor model with the Cessna 172 aircraft model. The corresponding Bode plots can be found in Figure 7.16. A sensor gain reduction of 1/3 using the same Cessna 172

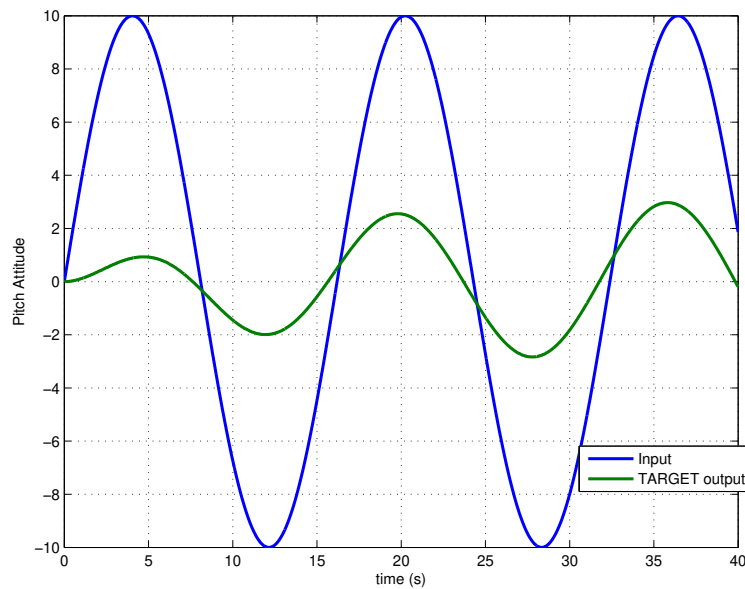
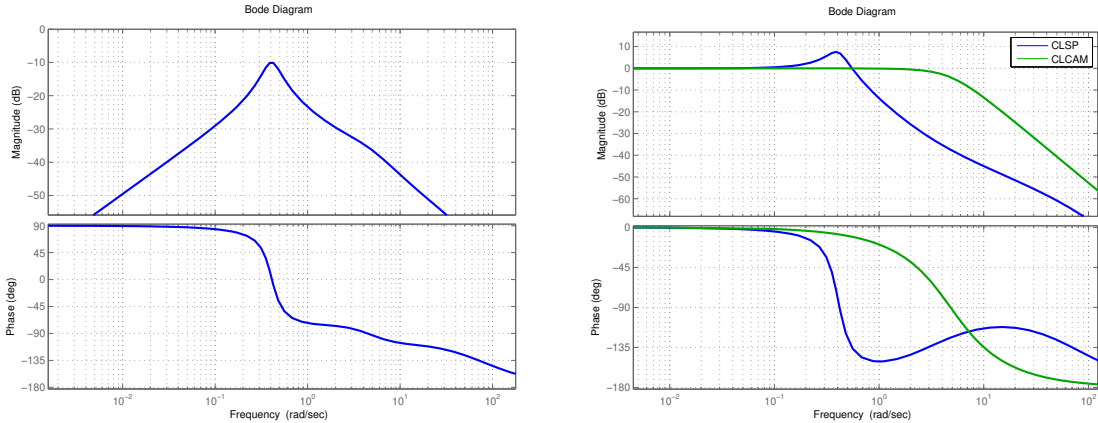

Figure 7.13: Time history of Cessna 172 short period model and sensor using TARGET SISO model.

model can be found in Figure 7.17 with corresponding Bode plots in Figure 7.18. By changing the sensor's bandwidth alone, the ability of the sensor to reject the aircraft's dynamics is dramatically effected. From these plots it can be inferred that the bandwidth of the sensor should extend beyond the peak gain frequency of the aircraft's short period in order to assure the sensor will be able to stabilize the vehicle dynamics.

7.3.1.4 MIMO Analysis Case

The MIMO case must also be analyzed, specifically for the case where the sensor is commanded to move to a new target location while still rejecting aircraft motion. The output of the MIMO case in Equation (7.2) is the commanded Target pitch attitude, while the inputs are the commanded sensor pitch angle and the commanded aircraft pitch attitude. The MIMO case can be considered to be the superposition of two SISO cases, first the term used in the previous SISO analysis, $-\theta_{a/cc}C_{L-SP}(C_{L-sens} - 1)$, and second $\theta_{cs}C_{L-sens}$. The first case serves as a penalty on the sensor



(a) Bode plot of SISO analysis using Cessna 172 short period and sensor model.

(b) Bode plot of individual systems of the Cessna 172 short period and sensor model.

Figure 7.14: Frequency analysis of SISO system for aircraft and sensor dynamics.

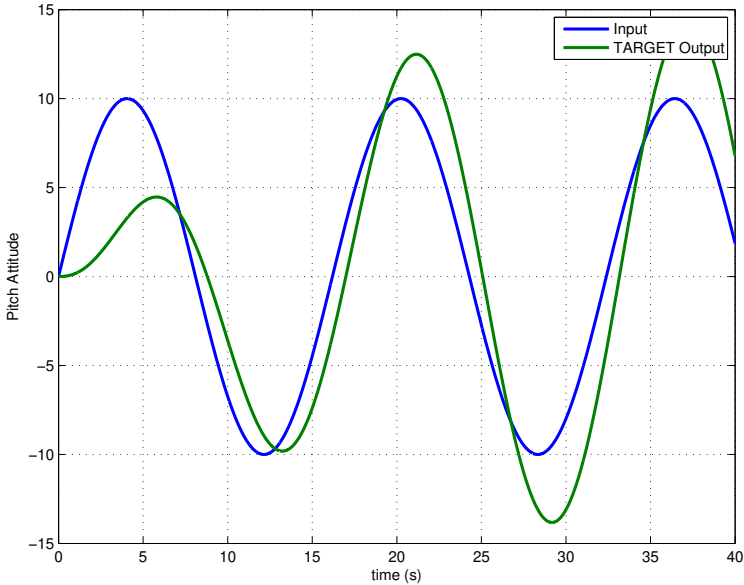
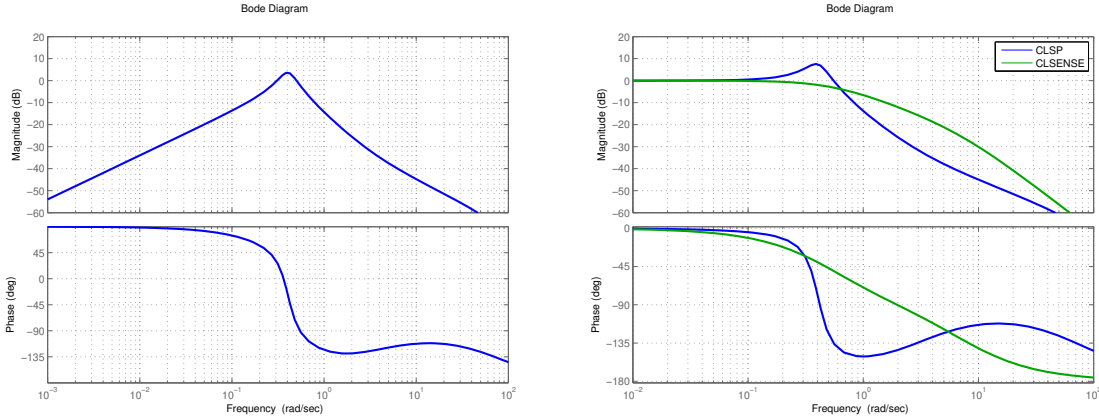

Figure 7.15: Time history of Cessna 172 short period model and sensor using TARGET SISO model with 1/6 system gain.



(a) Bode plot of SISO analysis using Cessna 172 short period and sensor model with 1/6 system gain.

(b) Bode plot of individual systems of the Cessna 172 short period and sensor model with 1/6 system gain.

Figure 7.16: Frequency analysis of SISO system for aircraft and sensor dynamics.

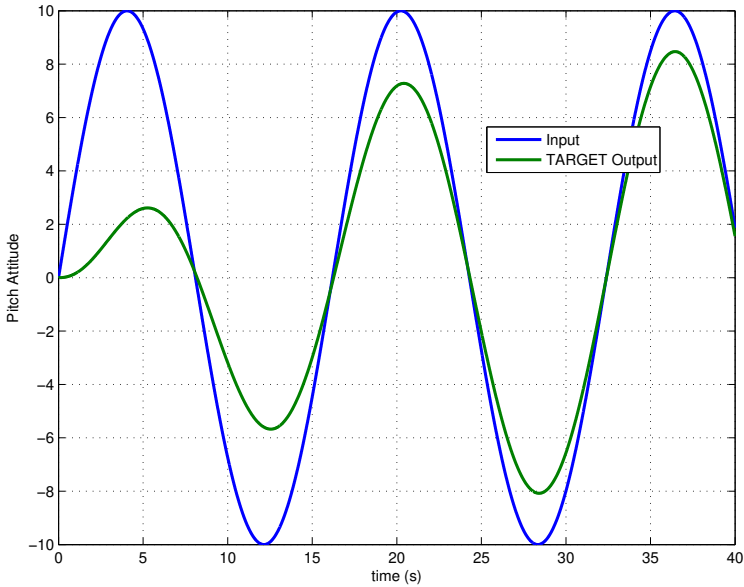
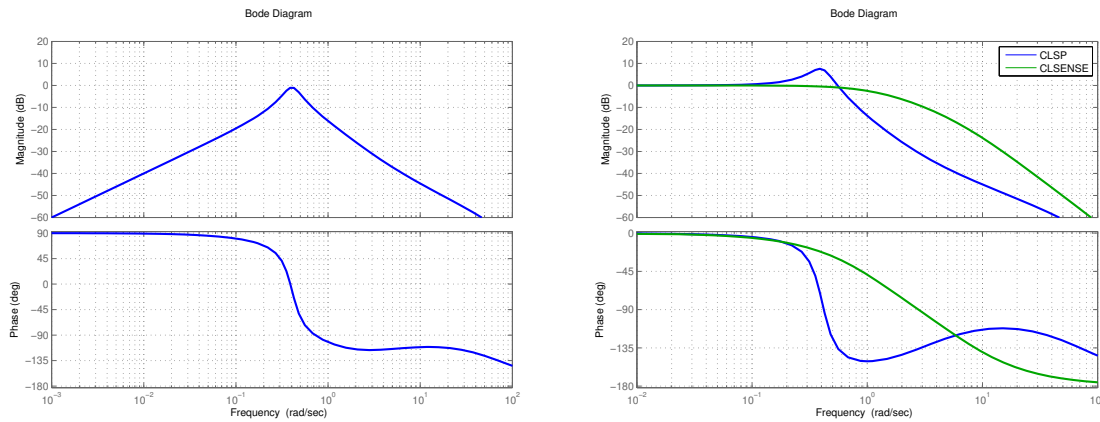

Figure 7.17: Time history of Cessna 172 short period model and sensor using TARGET SISO model with 1/3 system gain.



(a) Bode plot of SISO analysis using Cessna 172 short period and sensor model with 1/3 system gain.

(b) Bode plot of individual systems of the Cessna 172 short period and sensor model with 1/3 system gain.

Figure 7.18: Frequency analysis of SISO system for aircraft and sensor dynamics.

dynamics in achieving the desired outcome. This penalty can be analyzed as in the SISO case to find the reduction in ability to track the desired sensor command due to the aircraft's dynamic response. Just as before, the sensor's bandwidth must be larger than the aircraft's peak gain frequency in order to counter the dynamics of the aircraft. The second case $\theta_{cs}C_{L_{sens}}$ determines the sensor's ability to track a given target without aircraft dynamics. The superposition of these two will then give the integrated vehicle's performance. Figure 7.19(a) is an example of the aircraft moving and the sensor being commanded to remain stationary. Figure 7.19(b) is an example of the aircraft moving while the sensor is being commanded to move as well.

7.3.2 A Criterion with Winds

While the simplified system shown above may prove to be useful in a large subset of UAV maneuvers, it is not all inclusive. The destabilizing effect that wind has on a vehicle must include both phugoid and short period modes. In order to account for both modes and the wind inputs, as well as vehicle and sensor commands, a SISO system is no longer practical for consideration. An approach must now be used to characterize the integrated aircraft and sensor system. It is tempting to include all inputs and outputs, and to in effect overly complicate the system. The key to finding a criterion

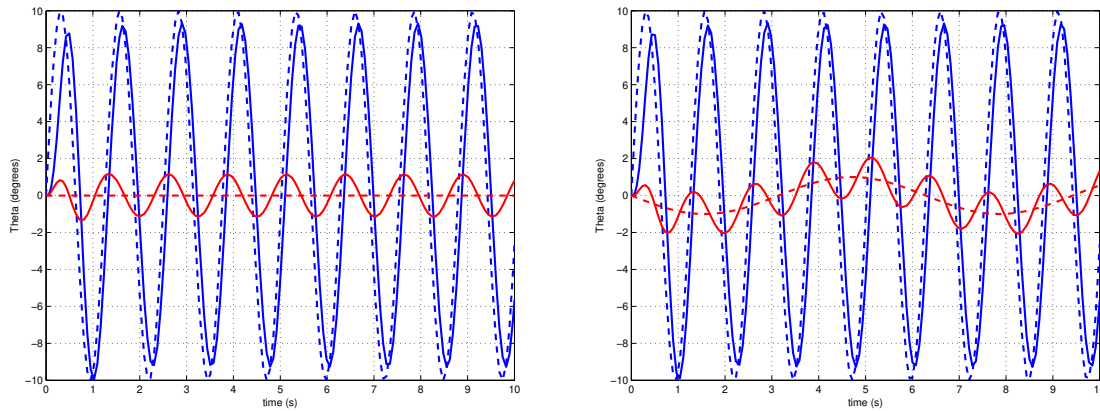

(a) Frequency interaction between aircraft and sensor with zero command to sensor. The solid lines are responses, dashed lines are commands, and the large amplitude response is the aircraft, and the small amplitude response is the sensor.

(b) Frequency interaction between aircraft and sensor with frequency command to sensor. The solid lines are responses, dashed lines are commands, and the large amplitude response is the aircraft, and the small amplitude response is the sensor.

Figure 7.19: Interaction between sensor and aircraft

of this sort is to create a minimal set of inputs and outputs that can be used to create a meaningful metric for analysis. Special attention must be paid to determine the correct input and output planes for analysis as well as their content.

7.3.2.1 Wind Effects

Wind turbulence models treat an aircraft as a point mass, and provide linear velocity perturbations to the vehicle's trajectory. Whether choosing the Dryden¹³¹ or Von Karman¹³² turbulence models, their basic effect on an aircraft is the same.¹³³ The linear displacement of the aircraft will cause a pointing angle error for the sensor, and changes in angle of attack of the aircraft will cause changes in the rotation (short period mode) of the aircraft as well. A graphical illustration of this system can be found in Figure 7.20.

While turbulence effects the linear motion of the aircraft disturbing it as a point mass, the coupling may occur between short period and longitudinal modes, causes a pitch response. Taking the knowledge that turbulence imparts a point mass acceleration, turbulence can be treated mathemati-

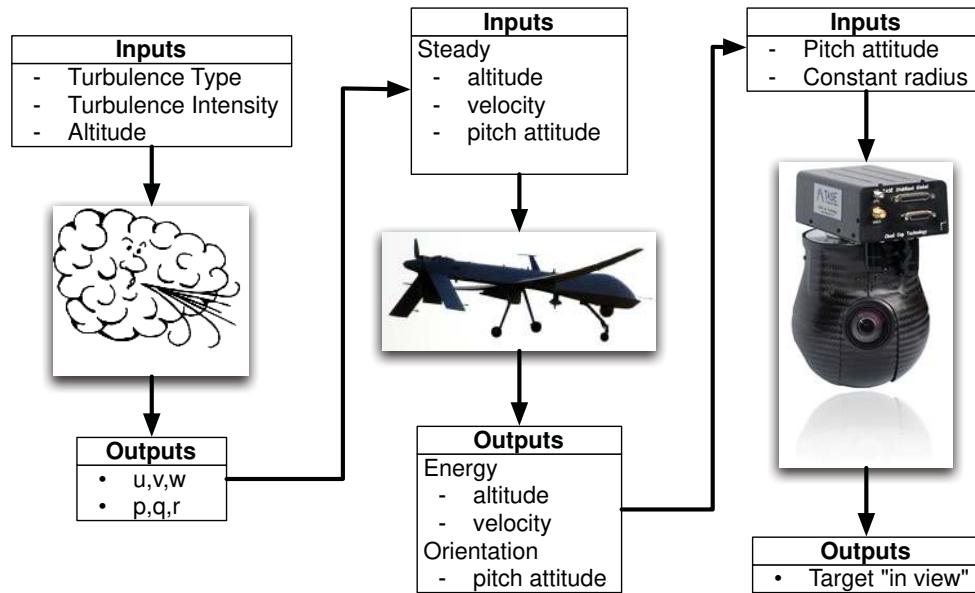

Figure 7.20: The influence of wind turbulence on aircraft motion and sensor errors.

cally as quickly adding and taking away power from the vehicle. Using this knowledge a metric can be constructed from the vehicle energy equations.

7.3.2.2 Energy Methods

The wind effects on the aircraft are taken as changes in aircraft energy state. As changes in energy they can be defined as aircraft power, and will impact the aircraft's trajectory just as an aircraft engine's thrust change would impact a trajectory. The equations of focus for this metric then become not the typical state equations, but the aircraft energy equations. The kinetic and potential energy for an aircraft can be described as

$$E = mgh + \frac{1}{2}mV^2 \quad (7.5)$$

where V is the total inertial velocity of the aircraft. Energy height E_h or specific energy is energy per unit weight, and can be described as :

$$E_h = h + \frac{1}{2g}V^2 \quad (7.6)$$

Specific power can then be represented as :

$$P_s = \dot{h} + \frac{1}{g}V\dot{V} \quad (7.7)$$

The wind turbulence models directly effect the altitude rate \dot{h} and inertial velocity V of the vehicle. Only by adding rotational energy can the short period be added into the power equation. The total specific energy with rotation can then be described as:

$$E_h = h + \frac{1}{2g}V^2 + \frac{I_{yy}}{2mg}\omega^2 \quad (7.8)$$

and the total specific power can now be described as:

$$P_s = \dot{h} + \frac{1}{g}V\dot{V} + \frac{I_{yy}}{mg}\omega\dot{\omega} \quad (7.9)$$

7.3.2.3 Metrics

Past work¹³⁴ has shown that finding detailed data on UAVs can be very difficult. Often, mass properties data such as pitch moment of inertia are not publicly available, or even known by the manufacturer. This creates a large challenge in using P_s in a criterion form. The solution is to use when possible what is available, and modify P_s to create a metric that can be used with available data for UAVs. While rigorously using an energy or power equation for a criterion is not practical due to a lack of information available for UAVs, the question then arises, can a metric be defined to include rotational, potential, and kinetic energy or power without all the information present? The first step to answering this question is to define the relevant, minimum set of information required

to quantify performance in winds. Using the MTE methodology a given task would have a level of wind turbulence. Specifically if the Dryden or Von Karman models were used the MTE would include an altitude above the ground and a probability of occurrence. Given a wind turbulence level, a change in allowable “power” must then be specified for a given objective. The MIMO outputs used in this metric would then be a vector whose individual components consist of the effects of kinetic, potential, and rotational energy. A factor can be placed in front of each vector component in order to weight the relative importance of each component to the full vector. These factors would replace the mass properties data that is lacking in UAV databases. The vector’s magnitude would then be a scalar quantity that can be used to determine the magnitude of the vector space. The MIMO input for this metric would also be a vector whose components are defined by allowable error for the sensor to track a given target, both in pitch attitude and range to target. The comparison of the MIMO input to outputs can then be done through relative magnitudes of the MIMO input and output vectors. This would give rise to the following equation:

$$\chi = \frac{\| \langle K_{i1} \theta_{err}, K_{i2} range_{err} \rangle \|}{\| \langle K_{o1} \dot{h}, K_{o2} V\dot{V}, K_{o3} \omega\dot{\omega} \rangle \|} = \frac{\sqrt{(K_{i1} \cdot \theta_{err})^2 + (K_{i2} \cdot range_{err})^2}}{\sqrt{(K_{o1} \cdot \dot{h})^2 + (K_{o2} \cdot V\dot{V})^2 + (K_{o3} \cdot \omega\dot{\omega})^2}} \quad (7.10)$$

where the values of K are chosen to change the emphasis of the various components of the metric. It should be noted that the values of K should be influenced such that χ is a non-dimensional number, so that comparison between aircraft can still be made. A bound is then a set of χ such as :

$$\chi_{min} \leq \chi \leq \chi_{max} \quad (7.11)$$

The values for χ_{min} and χ_{max} are determined by finding the maximum allowable magnitudes for the input and output vectors for a given task and placing bounds on their ratio. χ is the relative magnitude of sensor error to aircraft dynamic motion, where an ideal value of $\chi \rightarrow 0$, meaning the sensor could track its target no matter the aircraft motion. If the sensor error remains constant while the aircraft motion increases, the value of χ reduces, noting the more difficult task of maintaining

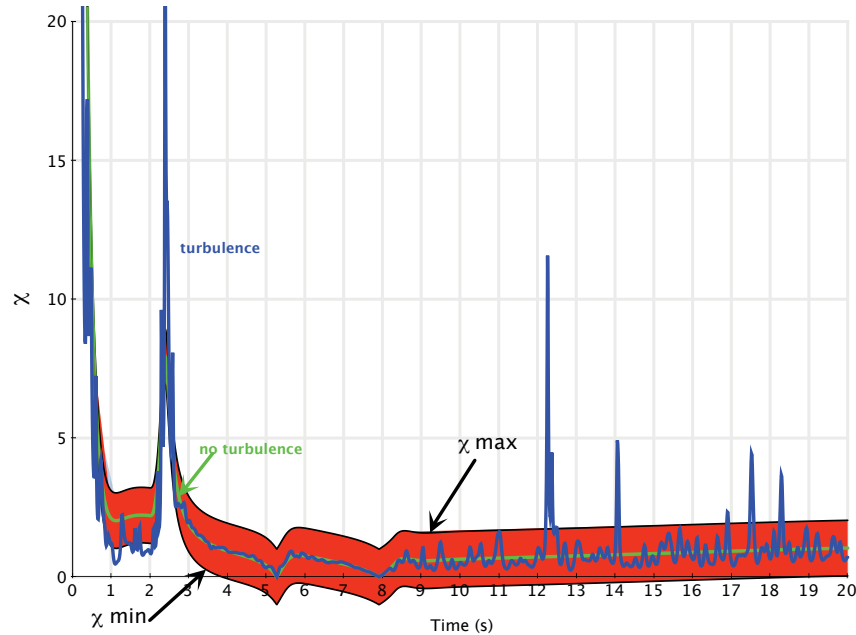

Figure 7.21: An example of boundaries placed on χ for a pitch doublet MTE.

a constant error in larger aircraft excursions. If the sensor error increases while the aircraft motion becomes constant, the value of χ would increase, showing poorer performance. The value of χ can be monitored during a specific task defined in a MTE, and the boundaries on χ would then be required to be met during the task performance. An example of the application of χ boundaries can be seen in Figure 7.21, where the red region is the allowable χ value above zero for the MTE of a pitch doublet. The green line is the MTE performed without turbulence, and resides in the center of the allowable region, and the blue line is the MTE performed with turbulence.

7.4 Simulation Trials

7.4.1 Simulation Testing

In order to test the new criteria two simulation environments were chosen. A linear, longitudinal aircraft simulation was created in Matlab[®] to primarily test and evaluate transfer functions. A full

nonlinear six degree of freedom simulation was also used based on NavAir's CASTLE simulation environment.

7.4.2 Aircraft Models

Three aircraft were chosen as the basis for airframe models in CASTLE. The choice of aircraft represents a broad range of UAVs taken from different classifications based on Classes II, IV, and V in Figure 5.8. The aircraft models used are based on the F-16 model found in Stevens and Lewis^{89,135} as well as a Cessna 172 model from Roskam,¹³⁰ and the Virginia Tech SPAARO.^{128,129} In order to match the representative Reynold's numbers in Figure 5.8, each aircraft was trimmed at a different operational point. These points can be found in Table 7.3. Longitudinal only models were constructed for linear analysis in Matlab[®], and full six degree of freedom airframe models were created for each airframe in CASTLE.

Aircraft	Altitude (ft, MSL)	True Airspeed (Kts)
SPAARO	1000 ft	53 Kts
Cessna 172	10,000 ft	120 Kts
F-16	30,000 ft	500 Kts

Table 7.3: Aircraft operational points used for testing in simulation.

For the CASLTE simulation, each aircraft starts off trimmed, and then is commanded to perform a pitch doublet at 2 seconds. The pitch doublet has a period of two seconds, and has a peak amplitude of 10 degrees. The aircraft begins the simulation at inertial coordinates $(\mathcal{X}, \mathcal{Y}) = (0, 0)$, with units of ft. During the simulation, the target is kept at a constant position of $(\mathcal{X}, \mathcal{Y}) = (1000, 1000)$ at MSL. The sensor on the aircraft is commanded to track the target on the ground while the aircraft flies over the target.

7.4.3 Sensor Model

The sensor model used for all four airframes was taken from experimental data gathered from a CloudCap[®] TASE gimbaled camera. The TASE is modeled to only move in pitch and was characterized on a hardware bench with the following transfer function:

$$\frac{\theta}{\theta_{cmd}} = \frac{G_{sens}}{G_{sens} + 1} \quad (7.12)$$

where G_{sens} is defined as:

$$G_{sens} = \frac{1}{s} \frac{1}{K} \cdot \frac{3}{0.1293s + 1} \quad (7.13)$$

where K can be varied to reduce the system bandwidth as required to adjust sensor dynamics for testing.

7.4.4 Testing the Simplified Pitch Criterion

The simplified pitch criterion can be tested by assuming that a MTE requires a commanded pitch attitude doublet at π rad/sec, or a period of 2 seconds while holding the sensor at a constant target. The aircraft mentioned in Section 7.4.2 are used to evaluate this task along with the sensor model in Section 7.4.3, with the gain $K = 1, 2, 3,$ and 6 . In Figure 7.22 the SPAARO airframe is used along with the different sensor gains in order to create a Bode plot of Equation (7.3). This system is excited at a frequency of 1 rad/sec and shown in Figure 7.23. This figure shows the variation of responses when there is separation in the different gain plots. Figure 7.24 is the linear response of the same system when excited at π rad/sec, showing small changes in the gain response of the different systems. This is a confirmation of the Bode plot gain in Figure 7.22. If the only task of interest is at π rad/sec, the best answer might be to find a different sensor for the SPAARO, but if this amount of sensor oscillation is acceptable, any gain set for the sensor would be acceptable. If a wider range of frequency operation is desired, the choice then becomes the $K = 1$ sensor, at the 1 rad/sec excitation case.

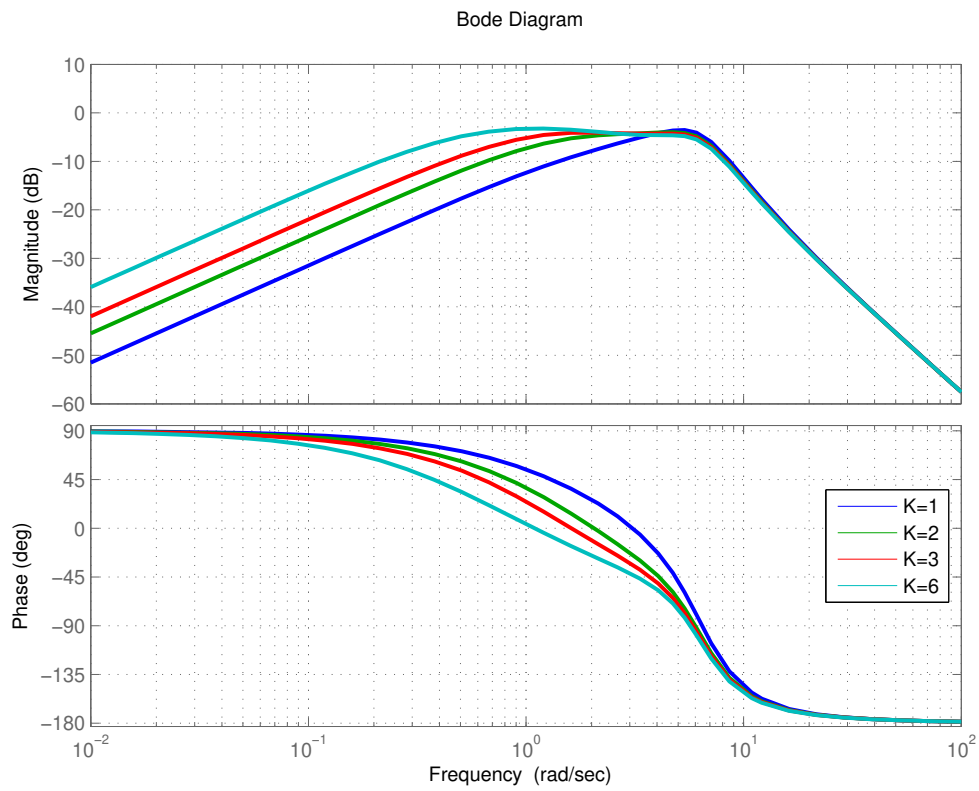

Figure 7.22: Bode comparison of sensor models with SPAARO aircraft dynamics.

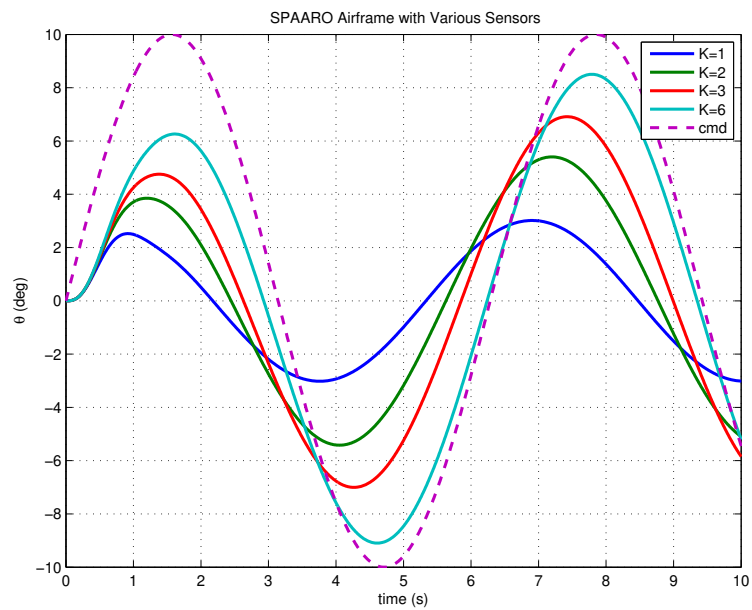

Figure 7.23: Linear simulation comparison of sensor models with SPAARO aircraft dynamics, input at 1 rad/sec.

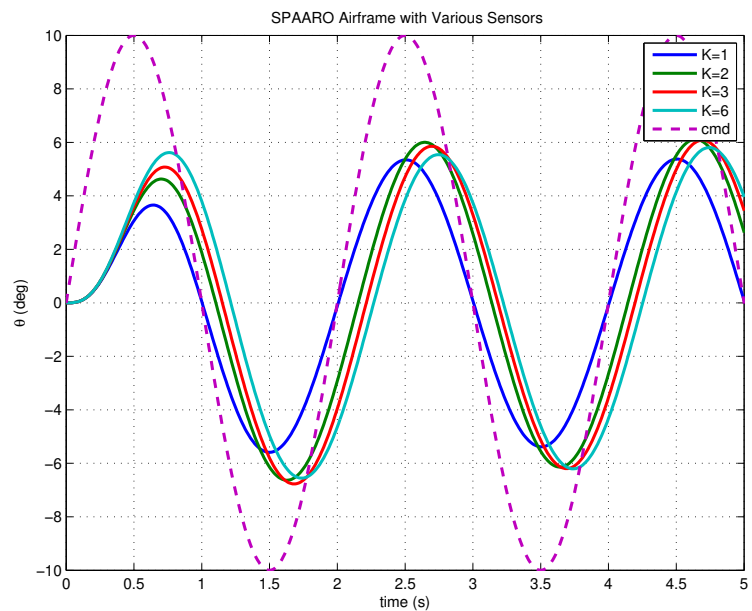

Figure 7.24: Linear simulation comparison of sensor models with SPAARO aircraft dynamics, input at π rad/sec.

Continuing this example, the next step is to explore the use of other aircraft with the $K = 1$ sensor. Figure 7.29 is a Bode plot of Equation (7.3) with all the aircraft in this example using the $K = 1$ sensor. The three aircraft show similar results, with the SPAARO model showing a smaller magnitude at π rad/sec, the Cessna 172 next larger, and the F-16 with the most gain. Figure 7.30 shows the linear simulation of the MTE with excitation at π rad/sec, confirming that the SPAARO has the least sensor movement.

Using the CASTLE simulation a pitch doublet was commanded to each vehicle. Each aircraft was initially configured as described in Section 7.4.2. The simulation was run twice with each aircraft, once with no pitch doublet to establish a baseline, and again with the pitch doublet. The SPAARO results can be found in Figure 7.25, while the Cessna 172 results can be found in Figure 7.26, and the F-16 results can be found in Figure 7.27. Taking the difference of the two traces in these plots yields the sensor tracking error during the maneuver, and the error for each aircraft is plotted in Figure 7.28. The SPAARO is shown to have the smallest tracking error, as also predicted in the linear analysis case.

7.4.5 Testing the Wind Criterion

The simplified pitch criterion does predict sensor pitch attitude errors based on aircraft pitch attitude displacement, but it can not account for the added sensor pitch motion associated with changes in aircraft energy. It is primarily a concern when airspeed or altitude changes, especially if these result from abrupt changes caused by turbulence that are too quick for the sensor to compensate. This can become a significant issue, especially if a camera sensor is being used, and the sensor is limited to a certain desired level of vibration. The same simulation tests as before were repeated in CASTLE with the Dryden turbulence model turned on, and with various levels of turbulence selected. Figure 7.31 shows the χ calculation for the SPAARO case with no turbulence, and the Figure 7.32 is the χ case for moderate turbulence. The spikes at two and four seconds represent the tracking errors previously shown in the simplified pitch criterion test. The area of interest, however, is the

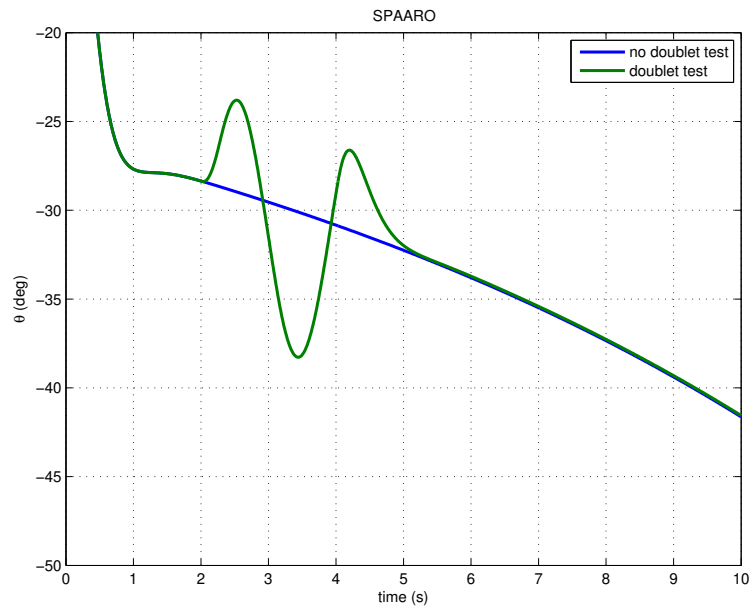

Figure 7.25: CASTLE 6-DOF simulation of SPAARO with sensor model gain $K = 1$.

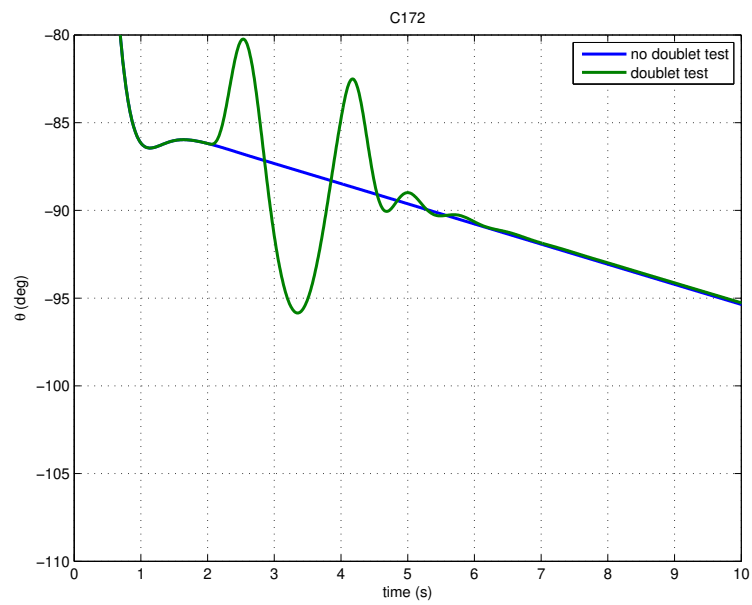

Figure 7.26: CASTLE 6-DOF simulation of Cessna 172 with sensor model gain $K = 1$.

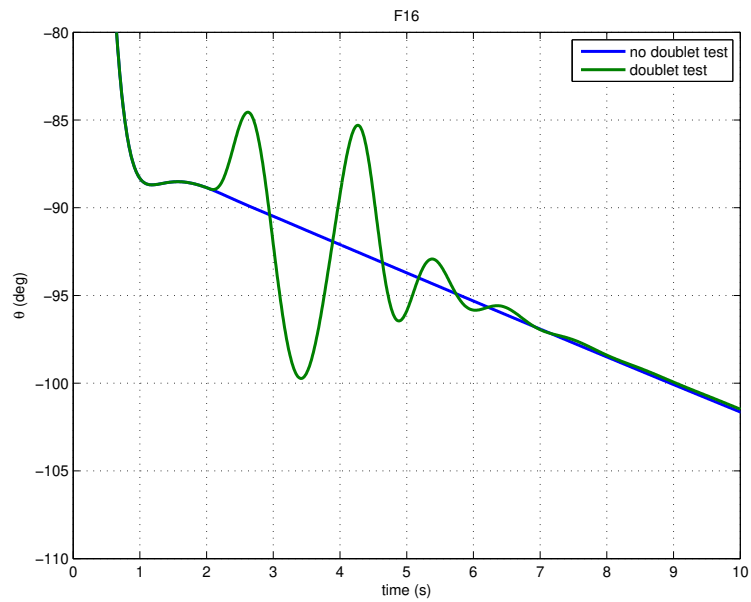

Figure 7.27: CASTLE 6-DOF simulation of F-16 with sensor model gain $K = 1$.

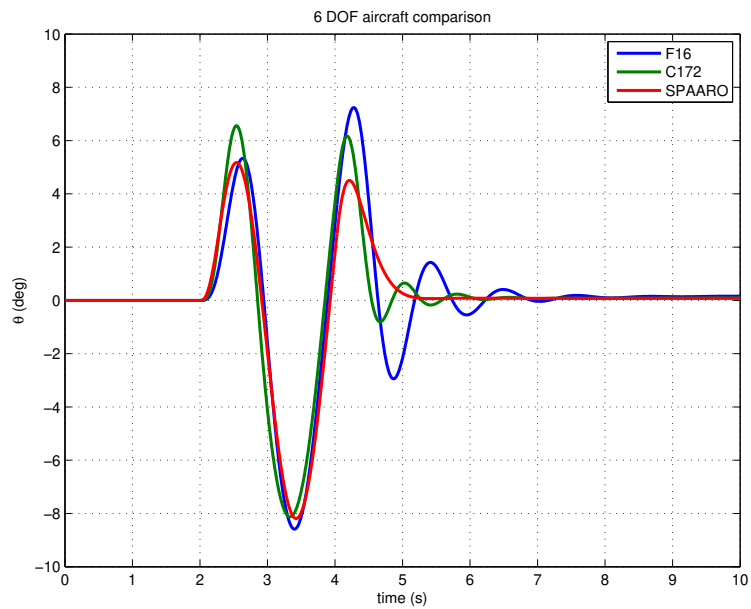

Figure 7.28: CASTLE 6-DOF simulation of all aircraft sensor pointing error.

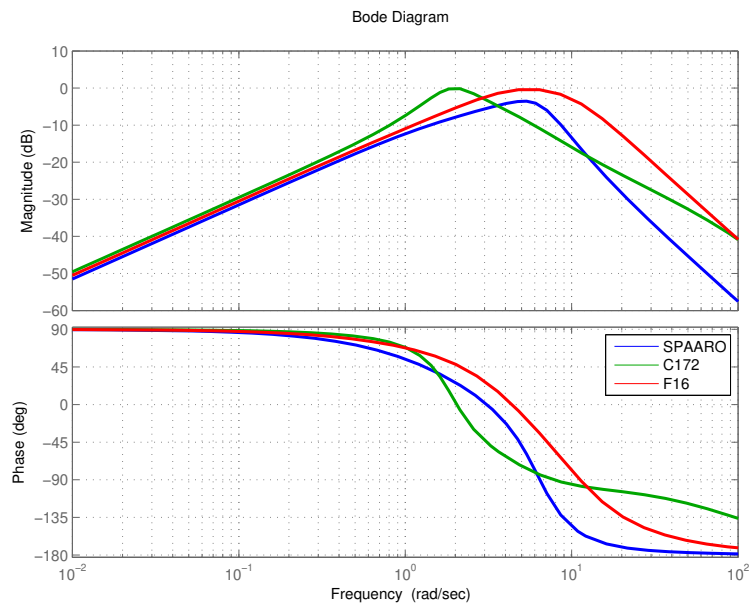

Figure 7.29: Bode comparison of all aircraft with sensor model gain $K = 1$.

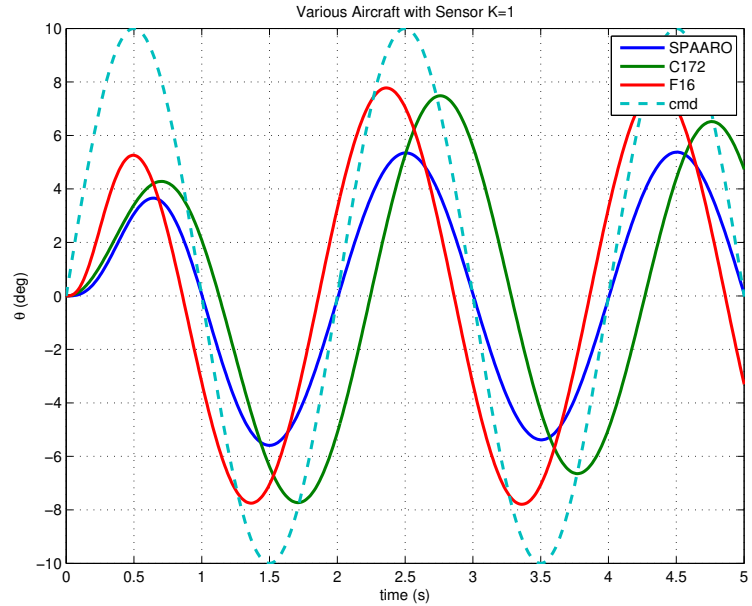

Figure 7.30: Linear simulation comparison of all aircraft with sensor model gain $K = 1$, input excitation of π rad/sec.

straight and level flight after the doublet, where the turbulent case shows frequency content in the χ calculation. Figure 7.33 and Figure 7.34 reflect the same no turbulence and moderate turbulence cases as those performed for the Cessna 172. This time the vehicle is moving faster and at a higher altitude, and the increased turbulence from being at altitude manifests in larger spikes and higher frequency of the spikes. This trend continues in the F-16 cases and can be seen in Figure 7.35 and Figure 7.36.

The increase in turbulence results in higher frequency content in χ as well as higher trending spikes. These values represent added vibration to the payload platform, which is the aircraft. The sensor would possibly have to overcome these vibrations to operate effectively. The boundaries on the χ levels, and possibly the frequency of oscillation would need to be established for a given mission or sensor tolerance. These vibrations are not quantified in the simplified pitch criterion because it does not take into account energy changes in the aircraft. Using this criterion with the simple pitch criterion, a full picture of the operational effectiveness of the sensor and aircraft platform can be achieved.

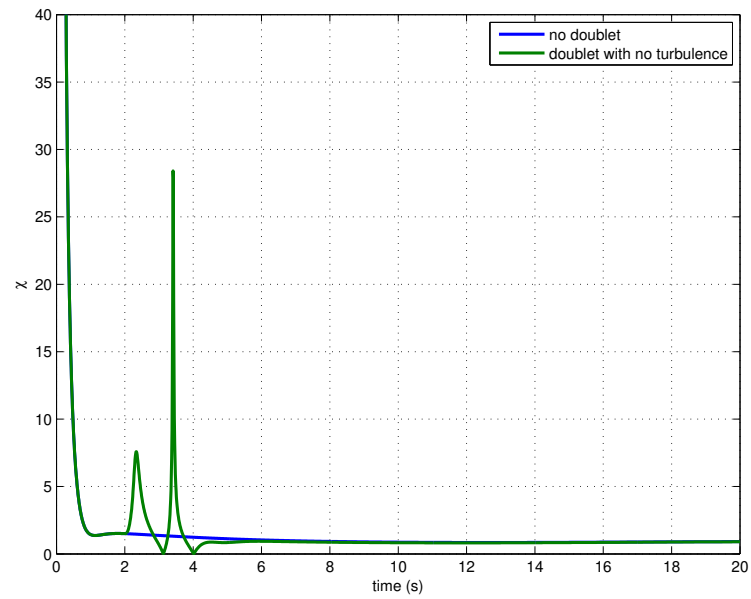

Figure 7.31: χ calculation using CASTLE 6-DOF simulation of SPAARO with no turbulence.

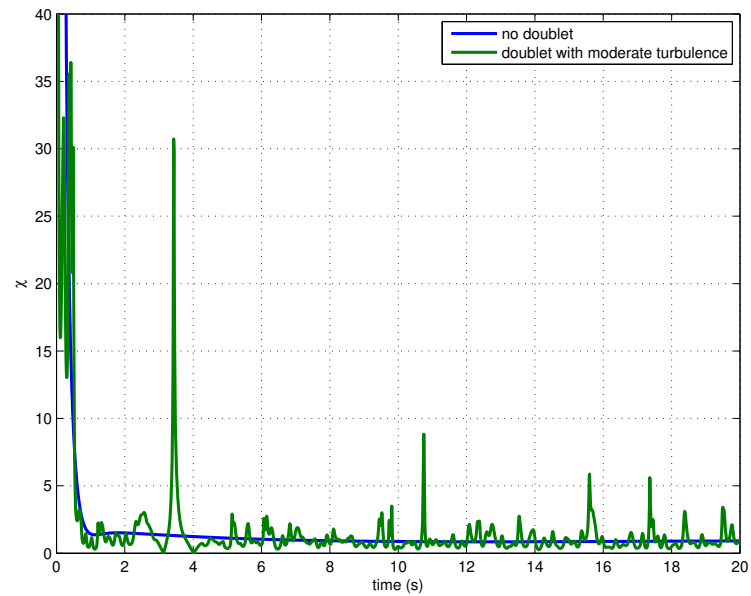

Figure 7.32: χ calculation using CASTLE 6-DOF simulation of SPAARO with moderate turbulence.

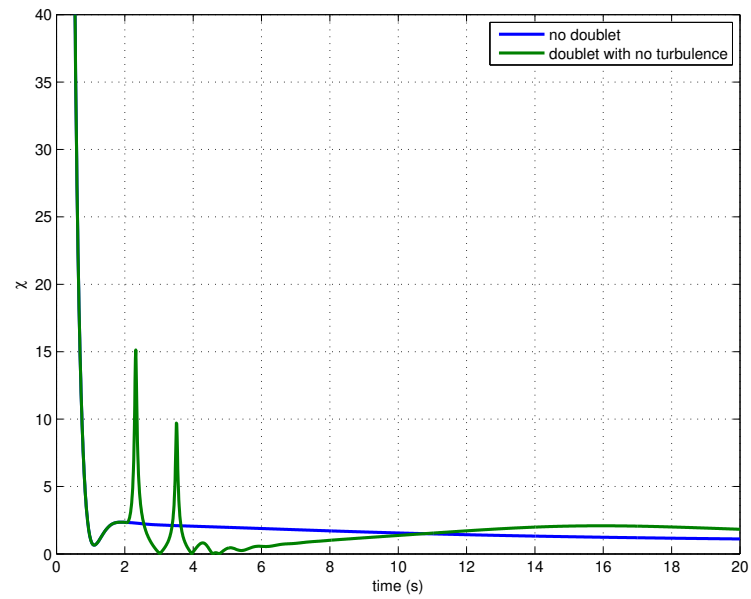

Figure 7.33: χ calculation using CASTLE 6-DOF simulation of Cessna 172 with no turbulence.

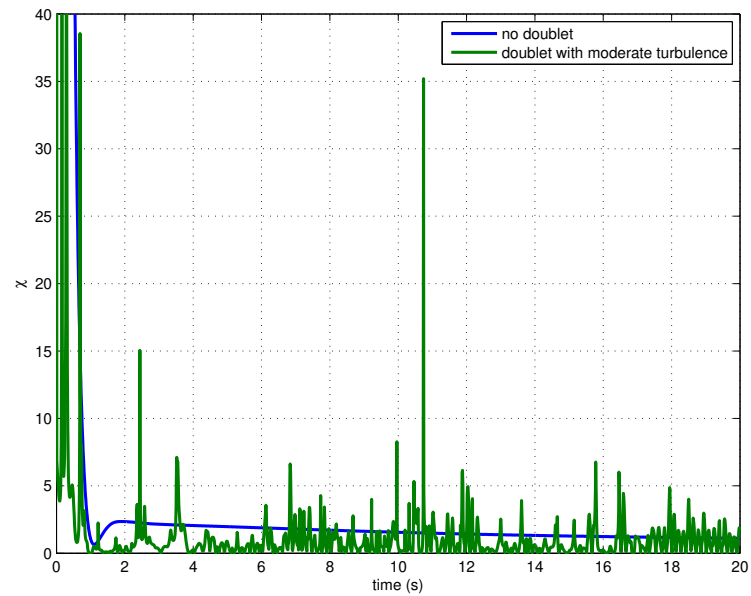

Figure 7.34: χ calculation using CASTLE 6-DOF simulation of Cessna 172 with moderate turbulence.

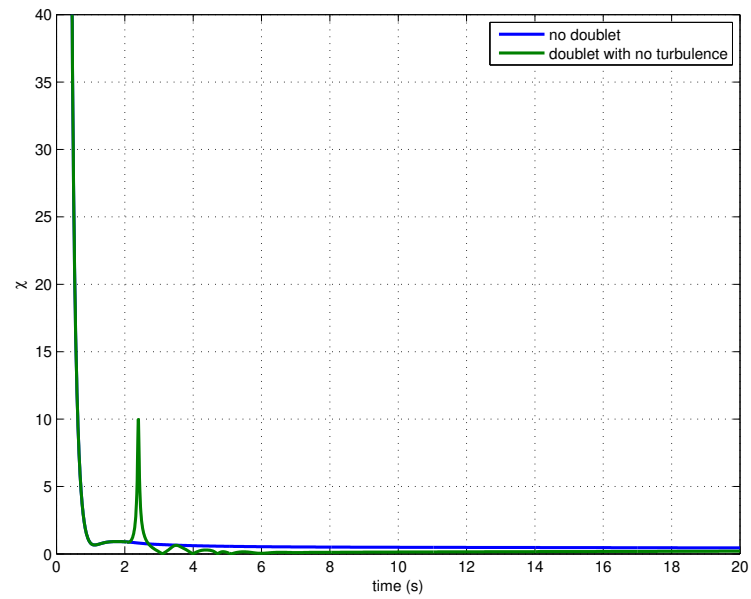

Figure 7.35: χ calculation using CASTLE 6-DOF simulation of F-16 with no turbulence.

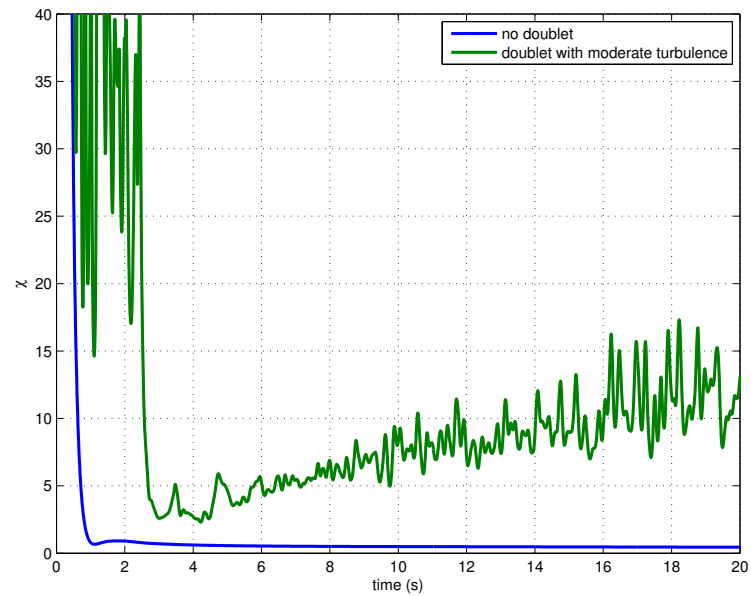

Figure 7.36: χ calculation using CASTLE 6-DOF simulation of F-16 with moderate turbulence.

7.5 Conclusion

The framework proposed in this chapter is inspired by piloted flying qualities criteria that were developed to predict the capabilities of human/aircraft interaction to perform a given task. In the case of a UAV where the pilot no longer present, a new criterion must be formed. While the new criterion can be inspired by previous piloted criteria, the new criterion must place as its first objective the ability to predict mission performance. The simplified pitch criterion and criterion with winds proposed in this chapter pay homage to piloted criteria, but are not limited by them. The overall framework proposed is a departure from those listed in MIL-STD-1797 and MIL-F-8785C, and proposes following the systems approach outlined in ADS-33-PRF, providing a more targeted and systematic approach to the use of the new criteria.

Open questions relating to this research still remain. The first open issue is the need to define a set of MTEs that can be used to establish boundaries for the proposed criterion. These mission tasks should be defined by operational considerations with the goal of creating a database of maneuvers that are representative of UAV mission segments. From these MTEs a guideline for allowable error in sensor pitch tracking could be established for each task. The MTEs would also define operational environments and give guidance to wind and turbulence conditions for a given task. This information could then be used to define χ parameter boundaries for the criterion with winds.

Flight and simulation testing of a larger set of UAVs would also be helpful in further evaluation of the proposed criterion. Testing should be conducted after a sample set of MTEs is defined to ensure relevance to future UAV mission operation. With a larger set of aircraft tested, a database such as the Neal-Smith database can be developed for UAVs aiding in further criterion development and evaluation.

The proposed simplified pitch criterion takes a complex system and abstracts it to a level where simple analysis can be performed to estimate mission performance of an aircraft and sensor system.

By using a linear systems approach the system can be analyzed using standard techniques familiar to those currently in the flying qualities community. Equation (7.3) gives the designer of the integrated system the ability to estimate the interaction between a sensor and the aircraft, and then choose the right combination of the two systems that will be operating at a know excitation frequency. As long as both the sensor dynamics and the aircraft dynamics can be modeled as a transfer function the system can be analyzed in this manner.

The proposed criterion with winds is a departure from standard flying qualities criteria in that it uses a metric based on energy methods to quantify the aircraft's motion in both the short period and phugoid modes. This allows for disturbances such as wind or turbulence to be factored into the criterion. With a sensor pointing at a target at a distance, the vehicle's center of gravity location as well as its pitch attitude are significant in determining the pointing vector for the sensor. With disturbances such as turbulence, sharp disturbances are imparted to the aircraft creating a vibrational environment that may have too high a frequency for the sensor to compensate. This criterion exposes that frequency content and allows for the prediction of high frequency disturbances to be considered.

Evaluation of UAVs and sensor systems during flight test will require a rating scale that can function in a similar manner to the Cooper Harper rating scale. While the questions filling the decision tree may need to be changed, the basic decision tree should be left in tact. The Cooper Harper rating scale was developed during the flight testing of aircraft for flying qualities evaluation. A new rating scale for UAVs should be developed in a similar manner. During flight testing unknown issues often occur, and the creation of this new scale could be done during early MTE development flight testing.

Ultimately the adoption of new flying qualities standards for UAVs will require both the United States government as well as industry approval. There will most likely be several different criteria proposed before one is adopted for wide use. By using the MTE approach, the criteria proposed here presents a targeted approach to UAV flying qualities. While this does not present a holistic approach

to UAV longitudinal flying qualities, and it does provide a starting point for future development. It is hoped that this work will spurn on further conversation in the flying qualities community and provide a starting point for others in the future development of UAV flying qualities criteria.

Nonlinear Flying Qualities

ADAPTIVE control has been considered as an attractive control architecture for future UAVs and piloted aircraft.⁵⁹ The use of nonlinear controllers that can adapt offers an alternative to classical controls to aircraft designers. Nonlinear controllers can be adapted to multiple airframes with minimal changes, allowing a generic control architecture to be developed and then reused for different vehicles. An example of this concept is the Honeywell MACH controller that was successfully flight tested on the X-35 and X-38 vehicles.^{59,136,137} Multiple applications from this concept have stemmed from research originally sponsored by the Air Force Research Laboratory.¹³⁸ The flying qualities evaluation of nonlinear controllers has offered large challenges to the flying qualities community, for both piloted and unpiloted aircraft.⁵⁹ This chapter describes a study to determine if an adaptive controller can recover level 1 handling qualities on a piloted, simulated aircraft in a degraded state. Using a piloted, motion-based flight simulator an evaluation of flying qualities was conducted to collect pilot's opinions and ratings using the Cooper Harper²³ rating scale. A simplified F-16 model⁸⁹ was used as the plant model to evaluate the controller. Four different aircraft models of varying handling qualities levels were used as a test data-set to determine if all four could be augmented via the adaptive controller to level 1 handling qualities. Two experienced test pilots were used to judge the aircraft flying qualities using the Cooper Harper Rating Scale, and then an attempt to correlate those results to a handling qualities rating was made. While simulator evalua-

tions are limited in comparison to full flight test, it is a safe and cost effective way to conduct initial research in a realistic environment. At the end of this chapter, open issues associated with nonlinear control and prediction of their handling qualities are discussed.

8.1 Introduction

A longitudinal study to evaluate the flying qualities of an adaptive controller was performed. The adaptive controller was used to compensate for a poorly performing aircraft's handling characteristics. Using a piloted, motion-based flight simulator an evaluation of flying qualities was conducted to collect pilot's opinions and ratings using the Cooper Harper²³ rating scale. A simplified F-16 model was used as the plant model to evaluate the controller. While simulator evaluations are limited in comparison to full flight test, it is a safe and cost effective way to conduct initial research in a realistic environment.

8.2 Background

8.2.1 \mathcal{L}_1 Adaptive Control Architectures and Their Verification and Validation

Adaptive controllers have been successfully flight tested for recovering nominal performance in the presence of modeling and environmental uncertainties.^{60,139} While the stability of these schemes follows from Lyapunov's direct method, the robustness analysis (stability margins) are being determined from Monte-Carlo simulations. It has been observed that increasing the adaptation gain for better performance leads to high frequency oscillations in the control signal and reduces the system's tolerance to the time-delay in the control and the sensor channels. The Theory of Fast and Robust Adaptation with its \mathcal{L}_1 adaptive control architectures has addressed these limitations for a wide class of systems,^{63,64,66-68,140-146} It allows for fast adaptation with guaranteed, bounded away from zero time-delay margin. The speed of adaptation is limited by the hardware, specifically the

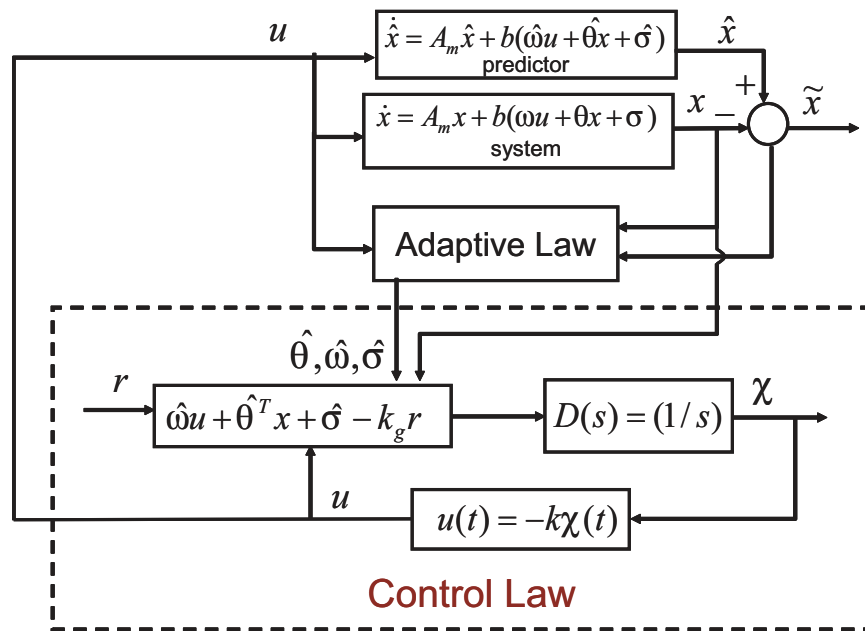

Figure 8.1: \mathcal{L}_1 adaptive control architecture.

computer processor.

Originally introduced by Cao and Hovakimyan^{141,142} for the class of systems with known high-frequency gain and constant unknown parameters, the underlying design paradigm of \mathcal{L}_1 adaptive control was later extended to systems with unknown high-frequency gain, time-varying unknown parameters and disturbances without restricting the rate of variation.^{64,140} Cao et al.^{64,140} predict the uniform performance bounds a priori for the system's input and output signals simultaneously, and also quantifies the stability margins, including the time-delay margin.

The underlying design paradigm of this new theory is the use of a low-pass filter in the feedback path that appropriately attenuates high-frequencies in the control signal typical for fast adaptation rates. Selection of the filter's bandwidth follows from a small-gain type argument, which then leads to guaranteed, bounded away from zero time-delay margin in the presence of fast adaptation. While

the adaptation law is still derived from conventional gradient minimization, the error signal $\tilde{x}(t)$ used in that process is the one between the system state and its predictor, Fig. 8.1. As in conventional Model Reference Adaptive Control (MRAC), the adaptive law retains its structure and the upper bound on the norm of $\tilde{x}(t)$ remains proportional to the rate of variation of uncertainties and inversely proportional to the adaptation gain. However, with the low-pass filter in the feedback path the \mathcal{L}_1 adaptive controller readily avails the opportunity to increase the adaptation rate without leading the system into high-frequency oscillations, while the small-gain theorem invoked for the stability proof leads to uniform performance bounds – inversely proportional to the adaptive gain, and guaranteed, bounded away from zero time-delay margin in the presence of fast adaptation.^{64,66,140}

The \mathcal{L}_1 adaptive control architecture and its variants have been verified and validated for various systems: flight test of augmentation of an off-the-shelf autopilot for path following,^{69,147} autopilot design and flight test for Micro Air Vehicles (MAV),⁷³ Tailless Unstable Military Aircraft,^{76,77} Aerial Refueling Autopilot design,^{71,72} flexible aircraft (Sensorcraft),⁷⁵ control of wing rock in the presence of faults⁷⁰ and air-breathing hypersonic vehicles.⁷⁴

It is important to note that the \mathcal{L}_1 adaptive control system is only intended to be active during a mismatch with desired aircraft performance. This mismatch may occur first as a transient and then as an error from the desired state that may or may not be constant. The adaptive control system's ability to drive this mismatch to zero will be key in determining the aircraft flying qualities while the adaptive controller is active. It is important, however, to not only look at an initial transient, but also at the long term response of the controller while active. For example if the adaptive controller is requiring 90% of pitch effectors to keep the aircraft trimmed and stable, a high rate pitch task may not be possible, and aircraft handling qualities would be affected purely by lack of control authority or possibly actuator rate limiting, and not just the dynamic controller response. While total system interaction by structural mode coupling and aeroservoelastic effects would be a major concern in

aircraft implementation, it was not investigated in this study due to simulation complexity.

8.2.2 Aircraft Model and SAS

The aircraft model used for this study was a simplified F-16 model¹⁴⁸ that supports six degree of freedom motion. The aircraft model is a clean F-16 (no external loads), and does not contain math modelling for high lift devices (flaps or slats), landing gear, or ground effects. The model does contain an after-burning turbofan jet engine with appropriate throttle lags modeled. The control inputs are δ_{PLA} , δ_e , δ_a , and δ_r . δ_{PLA} command is the power lever angle command (or throttle position), and its inputs range from 0 (flight idle) to 0.5 (full military thrust) to 1.0 (max afterburner), and is referenced as idle, MIL or MAX thrust, respectively. The three aerodynamic effectors are elevators (δ_e), ailerons (δ_a), and rudders (δ_r) all with a range of $\pm 25^\circ$. The elevators are primarily used for pitch control, the ailerons for roll control, and the rudders for yaw control, with PLA being used as engine control. The aircraft model does not include a sensor model, but relies on use of the actual aircraft states. A simplified atmospheric model was used as well. The aircraft model places the center of gravity location at 35% of the mean aerodynamic chord, resulting in an open loop unstable short period. The aircraft motion is described by the states found in Table 8.1.

A simple control system was implemented to modify the short period characteristics of the F-16 model. A block diagram of the system is shown in Figure 8.2. By feeding back the pitch rate and angle of attack the damping ratio and natural frequency of the short period was modified. This modification occurs by manipulating gains $K1$ and $K2$. The result is an augmented plant that can be easily changed to match Handling Qualities Ratings that are well documented.^{5,22} Four specific cases that can be found in Table 8.2 were created at a trim condition of steady, level flight, 10,000 ft MSL, 360 KEAS (709 ft/sec or 0.65 Mach), and an angle of attack of 1 degree.

8.2.3 Facility

State Index	Name	Description	Units
$x(1)$	V	body axis total velocity	ft/sec
$x(2)$	α	angle of attack	rads
$x(3)$	β	sideslip	rads
$x(4)$	ϕ	roll angle	rads
$x(5)$	θ	pitch angle	rads
$x(6)$	ψ	yaw angle	rads
$x(7)$	p	roll rate	rads/sec
$x(8)$	q	pitch rate	rads/sec
$x(9)$	r	yaw rate	rads/sec
$x(10)$	N	horizontal travel, North	ft
$x(11)$	E	horizontal travel, East	ft
$x(12)$	h	altitude (MSL)	ft
$x(13)$	pow	power, state used to find thrust	0 - 100 %

Table 8.1: Reference of vehicle states.

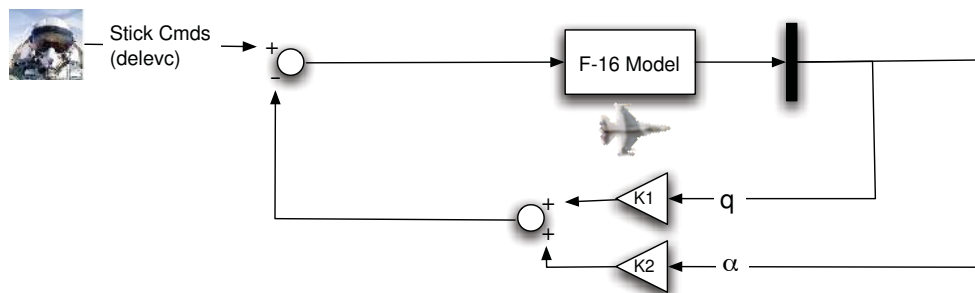

Figure 8.2: Augmented F-16 Plant.

Case	Natural Frequency ω_n	Damping ratio ζ	K_1	K_2
1	4.63 rad/sec	0.704	0.29	1.25
2	2.47 rad/sec	0.448	0.0	0.444
3	4.0 rad/sec	0.2	0.05	1.25
4	unstable	unstable	0.0	0.0

Table 8.2: Test Flight Cases

8.2.3.1 Simulator

The simulator used for this study was delivered to the Aerospace and Ocean Engineering Department of Virginia Tech on March 5th of 1996 from NAS Oceana in Virginia Beach. Originally an A-6E Intruder Operational Flight Trainer (OFT), the simulator was declared “in excess” when the Navy retired its A-6E’s and replaced them with F/A-18’s. The transfer was made possible with the help and support of research sponsors at Naval Air Systems Command Headquarters and at the Manned Flight Simulator branch of the Naval Air Warfare Center, Patuxent River, Maryland. A diagram of the simulation system can be found in Figure 8.3. The left (pilot’s) seat of the trainer cockpit represents the cockpit of a A-6E Intruder. The right seat has been modified to accommodate either an instructor or a flight test engineer with a computer driven CRT which can be custom configured with instrumentation as desired. The simulation computer has been converted to a SGI Origin 2000 computer. This allows the simulation of many different aircraft models, from a F-16 to a Cessna 152 to a Boeing 737 to a F/A-18. The A-6E Intruder aircraft flight controls, instruments, and systems, as well as its visual, aural, environmental, and motion sensations are combined with the desired aircraft software model to create a realistic flight experience. The three window visual display shows the surrounding terrain throughout take-off, maneuvers, and landing approach as a function of the aircraft attitude, altitude, and speed. Motion cues are provided by a three-degree of freedom cantilevered motion system. The simulator was originally procured by the Navy to provide pilot and air crew training for carrier based takeoffs and landings. While heavily upgraded, it retains its original capability.¹⁴⁹

8.2.3.2 IADS

Symvionics Inc. of Arcadia, CA has donated its flight test instrumentation software package called IADS[®] to Virginia Tech for use in their flight simulation laboratory. IADS[®] is a real-time data viewing tool that allows its user to view parameters from the aircraft simulation while the test is occurring. IADS[®] is an industry standard tool that is used in flight test by NASA, the US Air Force, and US Navy. IADS[®] also archives the data it displays for analysis purposes after the test.

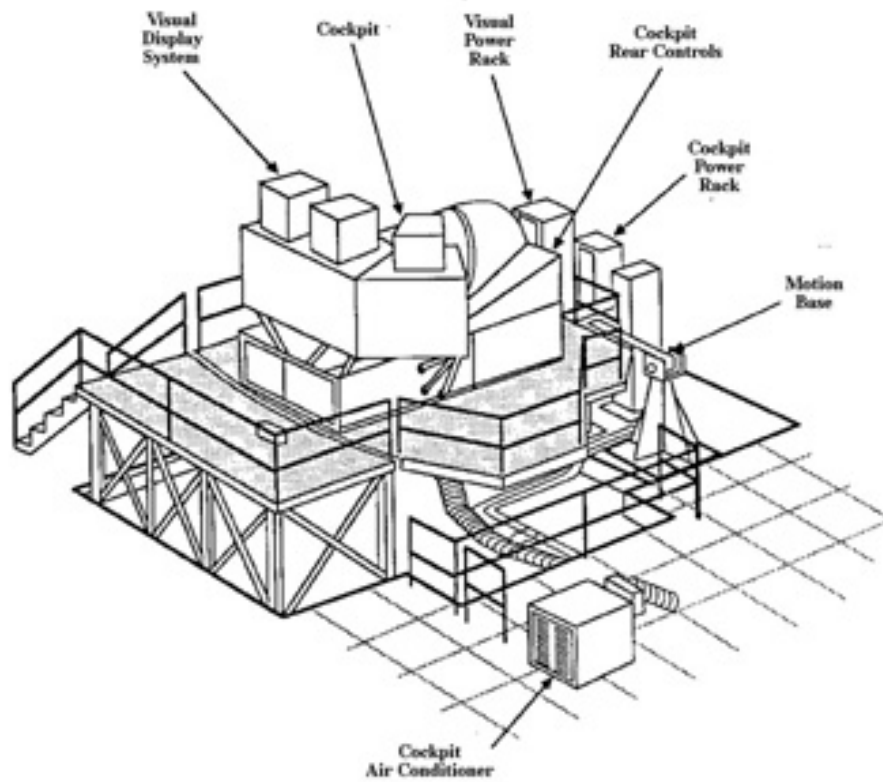

Figure 8.3: Diagram of Virginia Tech Flight Simulation System.

IADS[®] allows the user to customize the data displayed on the computer screen allowing the user to create data screens that are tailored to each test's requirements. IADS[®] has served as an important evaluation tool allowing realtime data visualization during and post flight test. Examples of IADS[®] displays used in this study can be found in Figure 8.4.

8.3 \mathcal{L}_1 Controller Implementation

A high level diagram of the \mathcal{L}_1 architecture implemented for this study can be found in Figure 8.5. For design and analysis purposes the controller was first implemented with a linear system aircraft model in Matlab Simulink[®]. The controller was then ported to the nonlinear 6-DOF CASTLE simulation. For both the linear and nonlinear aircraft model cases the same \mathcal{L}_1 controller was used. The augmentation scheme referenced in Table 8.2 was also used for both linear and nonlinear plants. The combination of augmentation schemes in Table 8.2 and the open loop aircraft model were used to create the Stabilized Plant block in Figure 8.5.

The primary interest of this study was the short period mode of the longitudinal motion. The phugoid was left out of the \mathcal{L}_1 design because it had no impact on the short period aircraft response. Lateral-directional control was implemented in the \mathcal{L}_1 controller for future use, but since no uncertainty in the lateral or directional motion is incorporated in this study, the \mathcal{L}_1 controller does not add any lateral-directional augmentation to the aircraft.

For this study the \mathcal{L}_1 controller was first designed with a linear system approximation of the aircraft equations of motion. The linear approximation was then replaced with the full nonlinear 6-DOF equations of motion. The general equations for aircraft dynamics can be presented in state space form as:

$$\dot{x}(t) = A_m x(t) + b (\omega u(t) + \theta^T(t)x(t) + \sigma(t)) \quad (8.1)$$

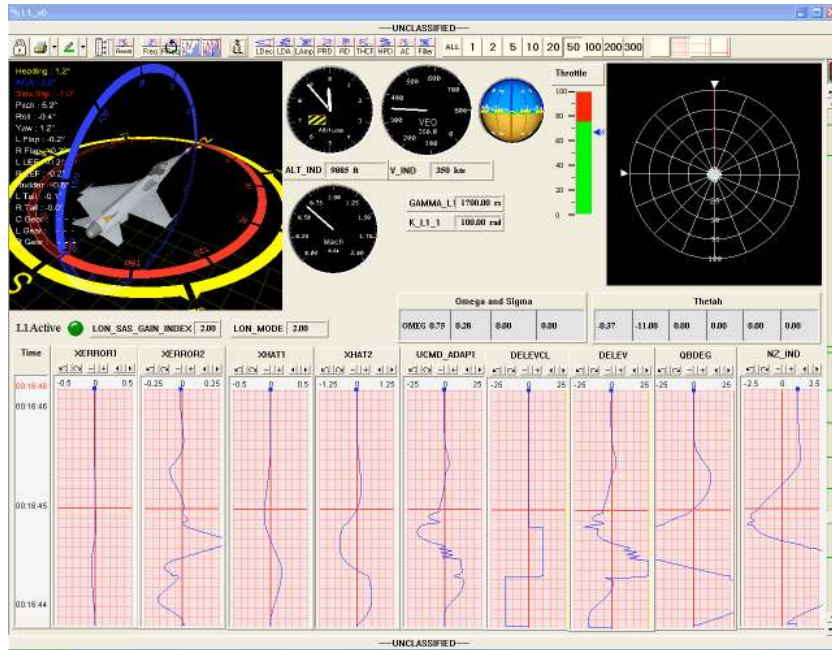

(a)

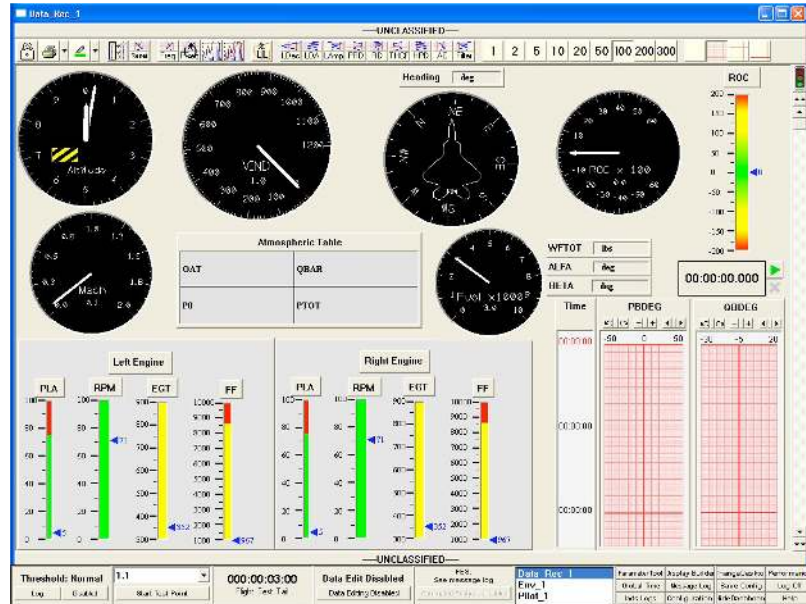

(b)

Figure 8.4: Sample IADS[®] data screens used for the study.

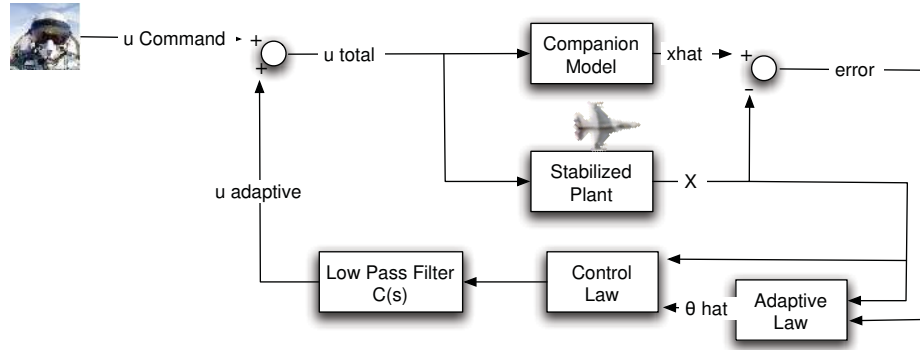

Figure 8.5: Block diagram of \mathcal{L}_1 controller.

where A_m corresponds to case 1 in Table 8.2, and the uncertainties are ω , $\theta(t)$, and $\sigma(t)$. The predictor is defined as

$$\dot{\hat{x}}(t) = A_m \hat{x}(t) + b \left(\hat{\omega} u(t) + \hat{\theta}^T(t) x(t) + \hat{\sigma}(t) \right) \quad (8.2)$$

where the adaptive estimates $\hat{\omega}(t)$, $\hat{\theta}(t)$, and $\hat{\sigma}(t)$ are updated according to the following adaptation laws:

$$\dot{\hat{\theta}}(t) = \Gamma_{\theta} \text{Proj} \left(-x(t) \tilde{x}^T(t) P b, \hat{\theta}(t) \right) \quad (8.3)$$

$$\dot{\hat{\sigma}}(t) = \Gamma_{\sigma} \text{Proj} \left(-\tilde{x}^T(t) P b, \hat{\sigma}(t) \right) \quad (8.4)$$

$$\dot{\hat{\omega}}(t) = \Gamma_{\omega} \text{Proj} \left(-\tilde{x}^T(t) P b u(t), \hat{\omega}(t) \right) \quad (8.5)$$

$$\Gamma = \Gamma_{\theta} = \Gamma_{\sigma} = \Gamma_{\omega} \quad (8.6)$$

with Γ being the adaptation rate, while

$$P = P^T > 0 \quad A_m^T P + P A_m = -Q \quad Q > 0$$

The projection operator¹⁵⁰ is defined as:

$$\Omega_c \triangleq \{\theta \in \mathbb{R}^n | f(\theta) \leq c\}, \quad 0 \leq c \leq 1$$

$$f : \mathbb{R}^n \rightarrow \mathbb{R}$$

$$f(\theta) = \frac{\theta^T \theta - \theta_{max}^2}{\epsilon \theta_{max}^2}$$

$$\theta^* \in \Omega_0$$

$$\text{Proj}(\theta, y) \triangleq \left\{ \begin{array}{ll} y & \text{if } f(\theta) < 0 \\ y & \text{if } f(\theta) \geq 0 \text{ and } \nabla f^T y \leq 0 \\ y - \frac{\nabla f}{\|\nabla f\|} \left\langle \frac{\nabla f^T}{\|\nabla f\|}, y \right\rangle f(\theta) & \text{if } f(\theta) \geq 0 \text{ and } \nabla f^T y > 0 \end{array} \right\}$$

A control law was then defined to provide command inputs to the augmented aircraft control system:

$$u(s) = -kD(s)r_u(s) \quad (8.7)$$

$r_u(s)$ is the Laplace transform of $r_u(t) = \hat{\omega}(t)u(t) + \hat{\theta}^T x(t) + \hat{\sigma}(t)$, and $D(s)$ is any transfer function such that it leads to a strictly proper stable filter transfer function

$$C(s) = \frac{\omega k D(s)}{1 + \omega k D(s)} \quad (8.8)$$

The choice of $D(s)$ and the gain k is subject to the following requirements:

$$\|G(s)\|_{\mathcal{L}_1} L < 1, \quad G(s) = (sI - A_m)^{-1} b(1 - C(s)) \quad (8.9)$$

$$L = \max_{\theta(t) \in \Theta} \sum_{i=1}^n |\theta_i(t)|$$

$$\omega \in \Omega_0 = [\omega_{lo}, \omega_{hi}], \quad \theta(t) \in \Theta, \quad |\sigma(t)| \leq \Delta_0, \quad t \geq 0$$

Letting $D(s) = 1/s$ Equation (8.8) becomes

Controller Parameter	Value
$k(1)$	100
$k(2)$	100
$k(3)$	100
Γ	17000
$D(s)$	$1/s$
θ_{lim}	± 100
σ_{lim}	± 100
ω_{lim}	$[0.5, 2]$

Table 8.3: Reference of \mathcal{L}_1 parameters.

$$C(s) = \frac{\omega k}{s + \omega k} \quad (8.10)$$

For digital implementation, the $1/s$ is approximated by the Tustin approximation where

$$s = \frac{2(z-1)}{T(z+1)}$$

For this particular implementation of the \mathcal{L}_1 controller the values used in Table 8.3 were used to configure the controller.

8.4 Results

8.4.1 Predicted HQR of Plant Models

Predicted longitudinal handling qualities were based on eigenvalue analysis of the short period found in MIL-F-8785C.^{5,22} Cases 1, 2, and 3 in Table 8.2 were investigated using these criteria to ensure a broad range of airframe characteristics during flying qualities testing. The load factor (n/α) and short period frequency ($\omega_{n_{SP}}$) comparison can be seen in Figure 8.6(a). Using this criterion alone Cases 1 and 3 appear in the Level 1 category while Case 2 appears in the Level 2/3 category. Investigating Control Anticipation Parameter (CAP) vs. damping ratio ζ_{SP} , the second part of the criterion yields further separation between the cases, as seen in Figure 8.6(b). From these

figures it can be seen that the cases are set to be correlated so that Case 1 has a predicted HQR of level 1, Case 2 has a predicted HQR of level 2, and Case 3 has a predicted HQR of level 3, with Case 4 being not classifiable because the short period is unstable.

8.4.2 Simulation Traces (Linear and Nonlinear)

Simulation test cases were run on each plant test case before \mathcal{L}_1 adaptive control was applied and then afterwards to contrast performance with and without \mathcal{L}_1 controller augmentation. For brevity only the responses with \mathcal{L}_1 are shown here. A double command (Figure 8.7) was given to both linear and nonlinear models to assure that the \mathcal{L}_1 controller and underlying models were behaving similarly. Figure 8.8 shows responses for all four cases in Table 8.2. For reference, Case 1 is the desired case for all responses. While Cases 2 - 4 do not identically match Case 1, the response in all cases showed similarities, even for the open-loop unstable case. Further the CASTLE (nonlinear model) and the Simulink (linear model) are not identical but very similar as well, showing that the system is responding as desired for both linear and nonlinear models.

8.5 Piloted Simulation Trial

For this study a piloted simulation trial was conducted with two experienced test pilots, referred to as Pilots A and B. One pilot is a retired U. S. Navy Test Pilot with over 3300 flight hours, and a graduate of the Empire Test Pilot School. The other pilot is currently a U. S. Air Force Test Pilot with 3000 flight hours and a graduate of the U. S. Air Force Test Pilot School.

8.5.1 Piloted Task Definition

The simulation trial was broken into two parts, the first (referred to as task 1) being a fully disclosed trial where a stick rap impulse was used to excite the different aircraft plant cases, both with and without \mathcal{L}_1 augmentation to familiarize the pilot with the different responses from each case. The instruction to the pilot can be found below.

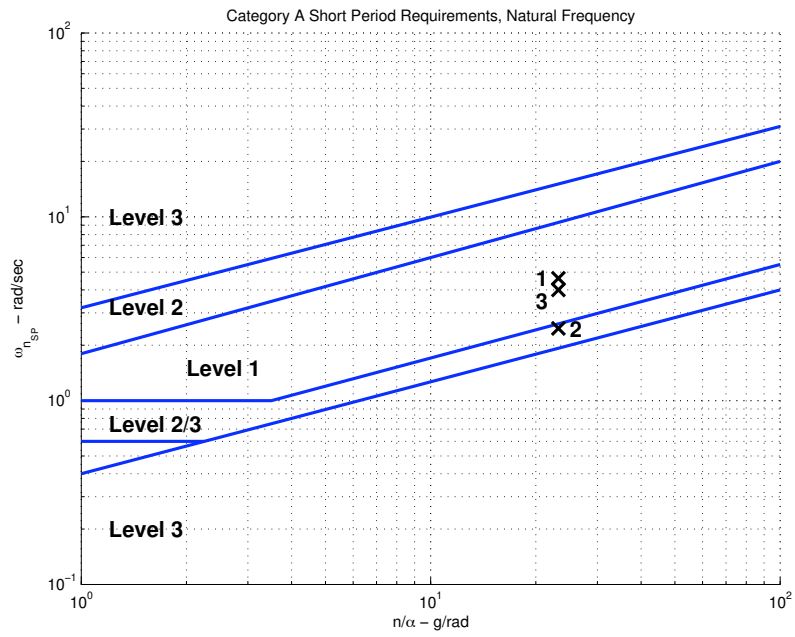

(a) Natural Frequency Criterion (ω_n).

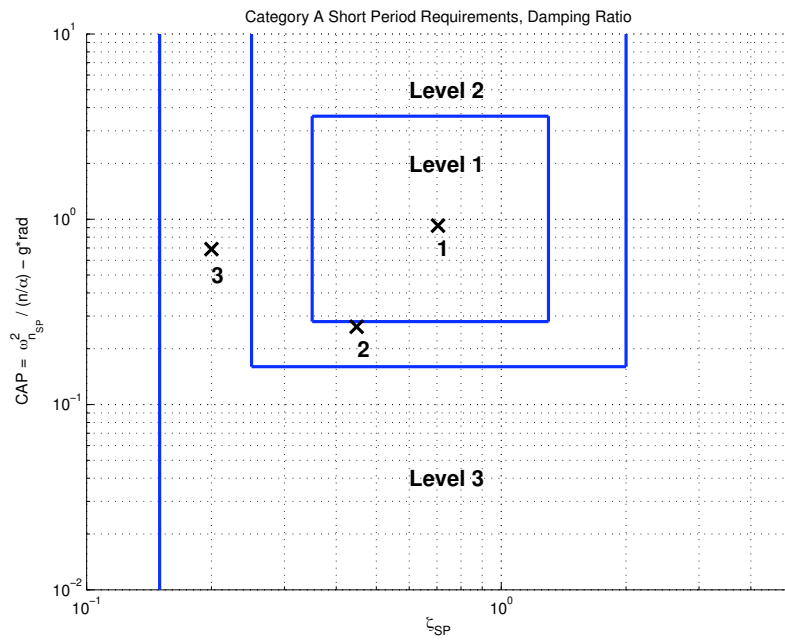

(b) Damping Ratio Criterion (ζ_{SP}).

Figure 8.6: MIL-F-8785C Short Period Criteria.

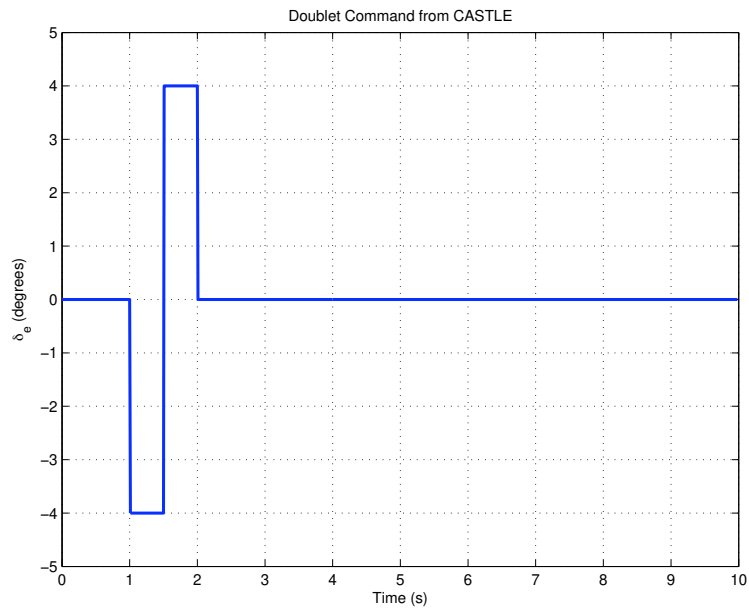
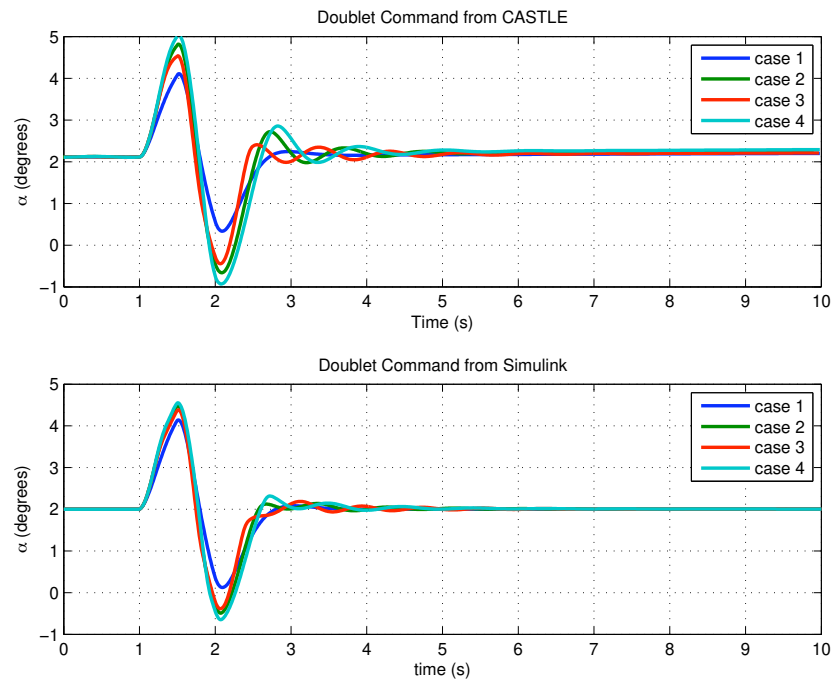
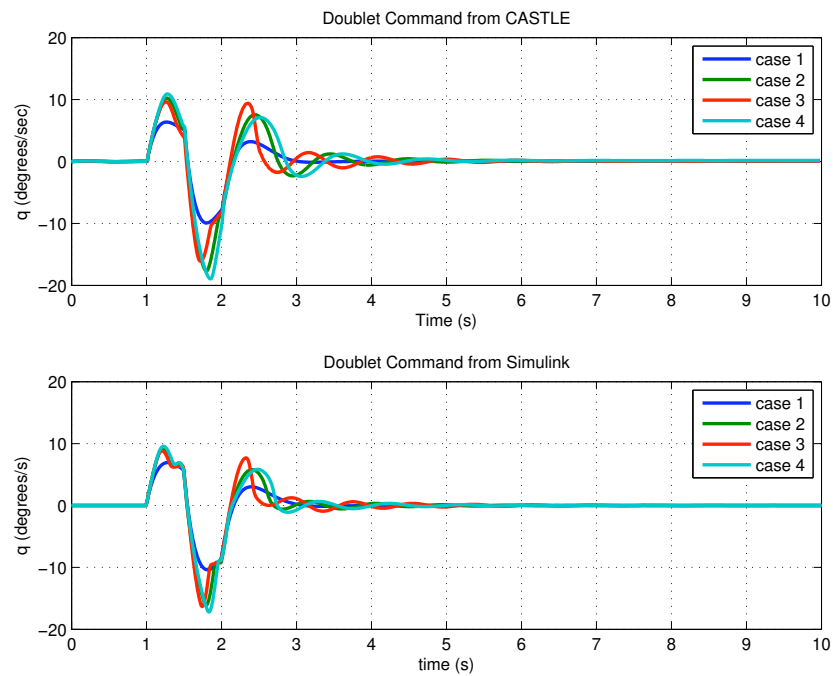

Figure 8.7: Doublet command used to test \mathcal{L}_1 controller response.

Objective: Observe and qualitatively comment on the short period natural frequency and damping for each airframe. This is not a blind test.

Task: Obtain level flight, 360 KEAS at 10000 ft. Trim aircraft, and verify with hands off stick. Quickly pull aft on the control stick and release to excite the short period mode of the aircraft with an impulse force. Observe and comment on the rise time and overshoot of the response to estimate flying qualities of the aircraft.

After the pilot was introduced to all eight cases (four with \mathcal{L}_1 augmentation, and four without \mathcal{L}_1 augmentation), a new set of tasks were performed (referred to as task 2). A target aircraft that is another F-16 using the Stevens and Lewis model¹⁴⁸ with a maneuver autopilot¹⁵¹ was flown ahead of the piloted aircraft at a constant altitude of 10,000 ft and 360 KEAS (709 ft/sec). The piloted aircraft was positioned 1000 ft behind and 200 ft below the target aircraft. The pilot was to aggressively capture the target aircraft within a bulls-eye found on the cockpit windshield. An example of the

(a) Angle of attack (α) response from linear and nonlinear models with \mathcal{L}_1 controller.(b) Pitch rate (q) response from linear and nonlinear models with \mathcal{L}_1 controller.**Figure 8.8: Doublet short period response with \mathcal{L}_1 controller.**

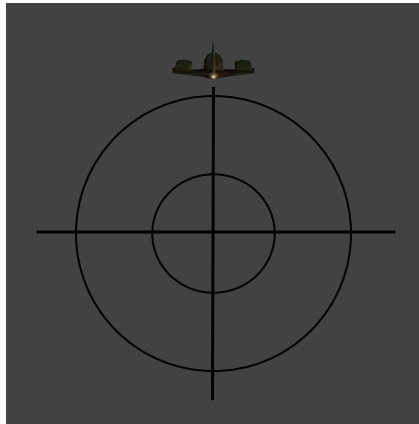

Figure 8.9: Pilot's view for pitch capture task.

pilot's view can be found in Figure 8.9. The pilot was to rate the difficulty of the task using the Cooper Harper Rating Scale.²³ The pilot was not told which aircraft model he was flying during the testing. The instruction to the pilot can be seen below.

Objective: Evaluate longitudinal flying qualities in a dynamic tracking task using Cooper-Harper rating scale. Note this is a blind test.

Task: Place tail light of lead aircraft just outside of the top ring in the bulls-eye, while maintaining 9800 ft altitude and near level flight, and approximate co-speed with the lead aircraft. When ready pull back on the control stick abruptly to move the target aircraft into the lower ring of the bulls-eye within 1 second. Then move the aircraft into the center of the bulls-eye within 1 second. The entire task should take approximately 2 seconds.

Adequate: Outer Ring

Desired: Inner Ring

8.5.2 Simulation Trial Results

8.5.2.1 Task 1

When asked to characterize the four aircraft models without \mathcal{L}_1 augmentation both pilots gave responses that correlated with predicted model behavior. Pilots A and B both described model 1 as “deadbeat.” Both pilots noticed the lower damping and slower frequency in model 2 as well. Pilot A responded that model 3 had “a lot of overshoot” and “poor damping” and that “the aircraft felt like it was going to diverge but did not.” Pilot B concurred that model 3 had poor damping as well. Pilot A referred to model 4 as having an “aperiodic divergence.” When the \mathcal{L}_1 controller was engaged Pilot B could not tell any difference in all four model responses, although he did state that the controls felt “heavier.” He further noted that all four models felt deadbeat, and “right on.” Both pilots noted that the aircraft had to be re-trimmed with \mathcal{L}_1 engaged. With \mathcal{L}_1 engaged Pilot A noticed small differences between models 3 and 4 but felt that models 1 and 2 behaved the same when \mathcal{L}_1 was engaged.

8.5.2.2 Task 2

The Cooper Harper ratings given by each pilot are presented in two forms in Table 8.4 and in Figure 8.10. Pilot ratings as presented in Figure 8.10 show that a significant improvement in aircraft handling does occur with “ \mathcal{L}_1 on” versus “ \mathcal{L}_1 off”. Further, agreement between aircraft model 1 with “ \mathcal{L}_1 off” is found with all “ \mathcal{L}_1 on” aircraft model cases. Both pilots judged all \mathcal{L}_1 controller cases as well as case 1 “ \mathcal{L}_1 off” (baseline reference case) as being either a 3 or 4 on the Cooper Harper scale. Pilot B correctly identified cases where the \mathcal{L}_1 controller was “on” versus “off” with the exception of the “ \mathcal{L}_1 off” aircraft model 1 case. As Pilot A was given more exposure to the different airframes with \mathcal{L}_1 controllers he noted that he was “learning the airplane” and that the task became easier. With airframe case 2 and “ \mathcal{L}_1 on”, Pilot A remarked “nothing to it,” and with airframe case 4 and “ \mathcal{L}_1 on” he remarked “very easy,” although some pilot compensation was required. Pilot A felt that the task as described for the case 2 and case 4 airframes with no \mathcal{L}_1 compensation was not achievable.

Aircraft Model	Pilot A		Pilot B	
	\mathcal{L}_1 Off	\mathcal{L}_1 On	\mathcal{L}_1 Off	\mathcal{L}_1 On
1	3	4	3	4
2	10	2	8	3
3	6	3	9	4
4	10	3	9	3

Table 8.4: Cooper Harper Ratings from Flying Qualities Test of \mathcal{L}_1 controller augmenting Short Period.

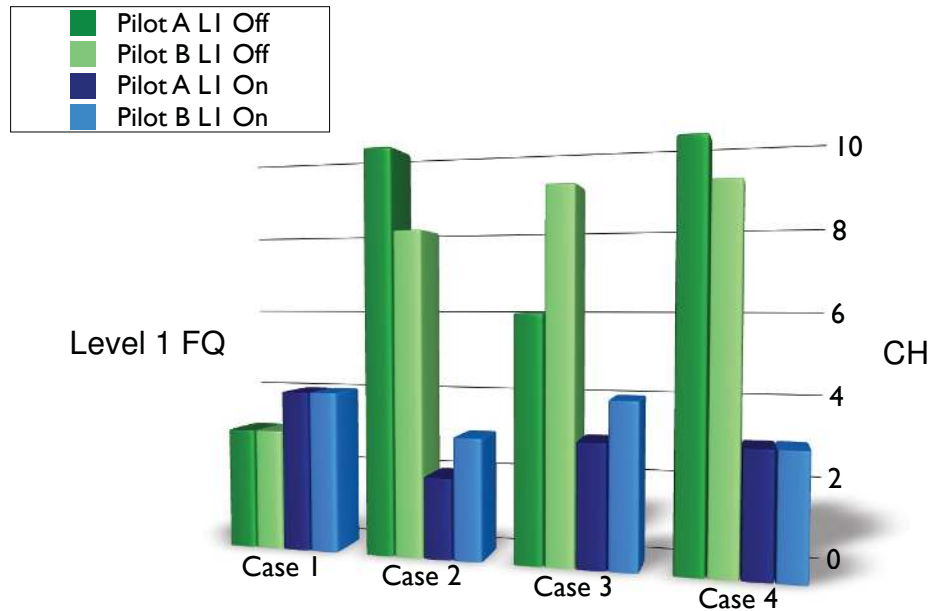

Figure 8.10: Piloted Cooper Harper Ratings Results.

From the eight different aircraft models presented, overall both pilots noted a considerable amount of re-trimming required for each aircraft model presented. Also, a lack of control harmony between the pitch and roll axes caused both pilots to pay more attention to the lateral aircraft response than expected. In general, a considerable separation between ratings was found with the \mathcal{L}_1 controller

“on” vs “off” for all but the case 1 airframe.

According to MIL-F-8785C, Level 1 flying qualities are “clearly adequate for the mission Flight Phase,” Level 2 flying qualities are “adequate to accomplish the mission Flight Phase, but some increase in pilot workload or degradation in mission effectiveness or both,” and Level 3 flying qualities are “such that the airplane can be controlled safely, but pilot workload is excessive or mission effectiveness is inadequate, or both.” Taking this as guidance, and to simplify data correlation, this study takes achievement of desired criteria (Cooper Harper rating of 1 - 4) as a level 1 flying quality, achievement of adequate criteria (Cooper Harper ratings of 5 and 6) as level 2 flying quality, and Cooper Harper rating of 7 -9 as Level 3 flying quality. Using this as a correlation between Cooper Harper rating and flying quality rating, all \mathcal{L}_1 cases were level 1, although several were on the lower edge of level 1. Most \mathcal{L}_1 off cases, however were level 3.

While aircraft simulation and flying real aircraft are similar, deficiencies in a simulation will make drawing direct conclusions from flying qualities data imprecise. This principle may explain why aircraft model case 1 was a marginal level 1 flying quality aircraft, although preliminary analysis shows it lying directly in the heart of the MIL-F-8785 level 1 envelope. Further complicating the analysis of the pilot rating is that only one pilot rated one airframe as a Level 2 flying quality aircraft although by prediction using MIL-F-8785C both pilots should have rated aircraft model case 2 as level 2 and case 3 as level 3. Noting that the majority of “ \mathcal{L}_1 off” cases were rated as level 3 by the pilots also raises the possibility that the task assigned may have been too difficult and over-exposed the weaknesses of the predicted level 2 and level 3 aircraft.

8.6 Open Issues in Prediction of Nonlinear Control Flying Qualities

While the simulator used in this study may introduce deficiencies in the testing for proper flying qualities, the pilot comments that the adaptive controller felt heavy or at times sluggish indicate that there are characteristics of the nonlinear controller that are not being captured in the flying qualities criteria prediction. Current flying qualities criteria use linear systems analysis techniques to predict piloted flying qualities. These linear systems analysis techniques first rely on the system being analyzed to be stable. From Lyapunov's indirect method a linear analysis of a stable system can also be inferred to be exponentially convergent.¹⁵² While this fact is taken for granted in linear systems analysis, often only stability and not a rate of convergence can be guaranteed in nonlinear systems. Nonlinear controllers such as the adaptive controller in this study therefore can produce characteristics that are not captured by linear analysis techniques. The equivalent time delay sensed by the pilots and described as heaviness in the control is an example of this problem. Specifically in adaptive controls the adaptation rate, or rate of convergence of the companion model can introduce either lag or unwanted dynamics in the vehicle response. The question then rises as to how fast must the convergence be in order for the vehicle to have desired flying qualities? If the convergence can be bounded, what are the bounds so that adequate performance can be guaranteed for pilot control?

Another issue associated with nonlinear controls relates to the zero dynamics,¹⁵³ especially in controllers that use forms of model following that are not adaptive. Zero dynamics can be considered to be the error between Equation (8.1) and Equation (8.2). The zero dynamics are therefore the dynamics that are left unaccounted by the nonlinear controller and experienced by the aircraft while the control law generates zero error. Adaptive controllers modify $\hat{\omega}(t)$, $\hat{\theta}(t)$, and $\hat{\sigma}(t)$ based on adaptive laws to minimize the zero dynamics. Control methodologies such as dynamic inversion do not modify these parameters, and as a result of modeling error zero dynamics will exist. The error and the dynamic shape of this error can then impact the aircraft's response to disturbances. The aircraft's response will then directly impact the vehicle's piloted flying qualities. Enns et al.¹⁵⁴

addresses the zero dynamics problem by careful selection of control variables in the dynamic inversion controller, however even in this case the zero dynamics may still exist. By defining a bound on the zero dynamics as well as their required characteristics a relaxing of the requirements for a vehicle's on board model may be possible.

Flight Mechanics and Flying Qualities in Engineering Education

ENGINEERING education requires a careful balance of theoretical understanding and practical application in order to foster an understanding of the complex principles covered in a typical curriculum. It can often be difficult to introduce practical applications into an engineering classroom that are complex enough to make an impact, yet simple enough to facilitate. This chapter documents the combination of concepts from several student centered pedagogues along with a unique asset to create a learning environment that could facilitate the reinforcing of theoretical concepts with practical applications to deepen the student's understanding of basic engineering principles. This particular combination was unique to Virginia Tech because of its possession of a unique asset, but the same application of pedagogues could be made elsewhere with other assets other disciplines of engineering.

9.1 Introduction

Teaching students topics in flight mechanics in an Aerospace Engineering curriculum presents challenges that are not usually present in traditional engineering programs. Because of the size, cost, and liability associated with operating full scale aircraft most aerospace engineering students only encounter pictures of an aircraft in a classroom. While scientific knowledge and theoretical concepts can be clearly communicated in a traditional classroom, practical experience with aircraft is not possible. Modern use of remote control aircraft in the aerospace curriculum aids students by giving them some practical experience, but it only gives students an experience by proxy, and not the immersive experience that flight in an aircraft brings. This creates a barrier to learning for students eager to fully understand aerospace engineering concepts in flight mechanics with no way to practice the concepts they have learned outside of traditional homework problems and tests. The result is that an aerospace engineering curriculum attracts students with great mathematical prowess and often excludes students with more practically based engineering skills. Education in engineering requires a balance of scientific knowledge and practical experience to cultivate well rounded engineers.

Due to safety issues, the cost of ownership of aircraft, liability concerns, and the cost of operating an aircraft, application of aerospace concepts learned in a classroom is often delayed until students arrive in industry. While a limited number of academic programs, particular those with aviation technology degrees, service academies, and Universities with facilities such as Mississippi State's Raspet Flight Research Laboratory can sustain actual flying coursework,¹⁵⁵ for the vast majority of aeronautical programs, the liability concern alone precludes putting students in an airplane. For example, in the late 90's, Penn State University was forced by insurance constraints to sell the Piper Arrow they used for aerospace education purposes.¹⁵⁶ As another example the University of Michigan offers a "Flight Test Engineering and Design" course that has been radically changed in recent years due to cost of operation of their Cessna R182.¹⁵⁷ While their students can still plan flight tests and analyze the limited data-set recorded from a production general aviation aircraft, the students

are not allowed access to the aircraft during flight. Access to modern military craft is exceedingly limited outside the service academies. In industry employees are expected to perform their tasks without time to revisit concepts learned in school. A means to allow students to apply lessons learned in a conventional classroom is needed in the aerospace curriculum so that when students arrive in the workplace they already have the requisite experience in applying their academic skills to real-world problems.

The National Academy of Engineering (NAE) challenges educators in *Educating the Engineer of 2020*⁷⁸ to pursue student oriented education. They encourage :

1. better alignment of engineering curricula and the nature of academic experiences with the challenges and opportunities graduates will face in the workplace and
2. better alignment of faculty skill sets with those needed to deliver the desired curriculum in light of the different learning styles of students.

The NAE also highlights a growing separation between practicing engineers and engineering faculty. The NAE states

“The great majority of engineering faculty, for example have no industry experience. Industry representatives point to this disconnect as the reason that engineering students are not adequately prepared, in their view, to enter today’s workforce.”⁷⁸

The National Research Council proposes in *How People Learn* that technology can be used to support learning by “bringing exciting curricula based on real-world problems into the classroom” and “building local and global communities that include teachers, administrators, students, parents, practicing scientists, . . .”⁷⁹ By using a Learner-Centered approach,⁸⁰ and Problem Based Learning (PBL)^{81,82} as a baseline pedagogy, available technology can be used to create a curriculum that directly answers the challenge offered by the NAE.

In the Spring semesters of 2006 and 2007, Virginia Tech's Department of Aerospace and Ocean Engineering offered an experimental course titled Flight Test Techniques, AOE 4984.^{158, 159} The course was designed to expose senior level undergraduates to industry and government accepted methods used in aircraft flight testing. Offering this course allowed real world problems to be introduced into the department's curriculum in a controlled environment. Building on the concept that hands-on application of concepts learned in an academic setting builds conceptual understanding, and is therefore a key to deep understanding,¹⁶⁰ this course serves as a capstone where concepts previously taught in several classes are integrated to give students an overarching view of aircraft flight mechanics, putting the theory students are taught in previous courses into practice. In order to facilitate a learning environment and mitigate safety issues associated with using real aircraft, two modern high performance aircraft models in the Virginia Tech Flight Simulation Laboratory are used instead of test aircraft. This aids completion of targeted learning objectives, while alleviating operational costs, weather concerns, and liability and safety concerns. Using the simulator also gives students the ability and opportunity to serve in all of the various roles required to flight test an aircraft, from test pilot, to test conductor, to discipline engineer.

The flight test techniques course aims to do more than instruct students in flight testing concepts. The flight test techniques class is designed to provide hands on experience with aircraft to foster application of the theoretical concepts taught in the aerospace curriculum. The course's curriculum is designed to create an environment where problem based learning facilitates social and role based learning under the guidance of teachers that are also industry experts. By guiding students as they convert their theoretical (procedural) understanding of aerospace engineering into a conceptual understanding of aerospace engineering they are no longer just dealing with abstract formulas, but are gaining fluency in the language of aerospace engineering and "learning to speak airplane."

While the Flight Simulation Laboratory at Virginia Tech is a facility that would be difficult to reproduce at most universities, the pedagogical concepts used in this course can be used to aid all

engineering curricular development. By using industry experts to frame real-world problems for students to solve we have been able to refocus the student's learning experience through immersion. This immersive experience is a carefully constructed environment that simulates how a practicing engineer would be required to perform the basic skills that they have been taught in their undergraduate curriculum.

9.2 Combining Pedagogues

According to Weimer,⁸⁰ in order to be considered Learner-Centered, teaching must include five elements. First the balance of power in the classroom must be shifted from the instructor to the students. By empowering students to become responsible for their own learning, the instructor becomes more of a facilitator and less of an authoritarian. Second, content is used as an aid to construct knowledge, instead of presenting a series of facts and figures. Concepts are taught to students, and they are encouraged to seek specific details to accomplish their assigned tasks from sources outside of the classroom. Third, the teacher must become more interactive with students, engaging the class in other forms besides just a lecture. Forth, the responsibility for learning must be shifted from the teacher to the students. Lifelong learning habits can be fostered by having students take ownership of the learning process. Finally, targeted assessment must be made to encourage students to not just learn material for a one time test, but to foster deep learning of concepts for long term retention. Problem Based Learning fits nicely into a Learner-Centered scheme, and was used to create the foundational pedagogy for the course.

Using problem based learning as a baseline pedagogy, cooperative learning, and role base learning can be used to enhance the learning experience. By using a multidimensional approach to designing a curriculum the impact to student learning can be maximized over a short period of time. This study uses an integrated approach to course design. Utilizing the interconnections and strengths between these three teaching approaches a realistic, yet safe environment for posing open-

ended problems can be formed.

Problem based learning can trace its formal roots to a desire to reform teaching in the medical field. Using a problem based learning approach, the McMaster University Faculty of Health Science graduated its first class in 1972. The College of Human Medicine at Michigan State University soon followed by implementing an alternative track using problem based learning. The success of these schools created a wave of medical schools adopting problem based learning tracts in their curriculum.⁸² Spaulding states the motivation for problem based learning as “Current dissatisfaction with medical education imposes on a new medical school a responsibility of experimenting with novel approaches.”¹⁶¹ Problem-based learning was documented in the United States by the Report of the Panel on the General Professional Education of the Physician and College Preparation for Medicine, known as the “GPEP report”¹⁶² sponsored by the Association of American Medical Colleges. This report gave credence to problem based learning to medical school deans and faculty. Curriculum changes were implemented to reduce lecture hours, increase independent learning and problem solving.

Engineering educators have long recognized the need for design in the curriculum. The Educational Development Program of UCLA considered design the “essence of engineering and have defined it as an *iterative decision making process* that we now recognize as the common discipline of all professions.”¹⁶³ Problem based learning lends itself well to incorporating design into a curriculum. Giving students open ended problems allows them to weight multiple options for a solution and is the essence of design. Traditional educational techniques use *convergent thinking* to focus on a solution with a specific set of answers that are verifiable and contain a *truth value*. In a design based instruction “the questioner is not necessarily concerned with the truthfulness or verifiability of potential answers.”¹⁶⁴ Whereas *convergent thinking* operates on the *knowledge domain*, *divergent thinking* operates on the *conceptual domain*, which may not be directly verifiable.¹⁶⁴

Barrows⁸² identifies six core features of PBL:

1. Learning is student-centered.
2. Learning occurs in small student groups.
3. Teachers act as facilitators or guides.
4. Problems are the organizing focus and stimulus for learning.
5. Problems are vehicle for the development of clinical problem-solving skills.
6. New information is acquired through self-directed learning.

Student excitement over solving real-world problems can be easily lost if the instructor is not considered an expert in the field.⁷⁹ It is not enough to be an academic expert in the field; real-world problems can only be accurately posed by those who have real-world experience. The real-world experience allows the instructor to pose the problem correctly and ensure that proper emphasis is placed.¹⁶⁵ The real-world experience is what separates the text book homework problem from the real-world problem. Without experience in real-world implementation, the posed problems of the instructor are no better than those found a text book.

An added benefit to problem based learning is that it lends itself well to group learning. Smith et. al.⁸¹ draw a distinction between structured cooperative learning and placing students into study groups. Formally structured cooperative learning groups must contain:

1. Positive interdependence
2. Face-to-face promotive interaction
3. Individual accountability/personal responsibility
4. Teamwork skills
5. Group processing

Students in a cooperative learning environment are encouraged to discuss the concepts presented to them by their instructor. By having an open discourse on the subjects they are learning, deep learning is encouraged. The students no longer just accept information presented to them, they explore the topic and adopt principles only after they have been vetted within their peer group.¹⁶⁶ Cooperative learning groups are very similar to highly productive teams outside of a learning environment. Katzenbach and Smith describe high-performance teams as:

“A team is a small number of people with complementary skills who are committed to a common purpose, performance goals, and approach for which they hold themselves mutually accountable.”¹⁶⁷

The instructor’s role is no longer that of a teacher, but more a facilitator. Guidance for methods of facilitation can be found outside of traditional academia in programs that are designed to build high performance teams. Rohnke and Bulter state that “the leader/facilitator doesn’t provide all the answers to the group; primarily the participants learn from each other.”¹⁶⁸ The authors go on to contrast leading versus facilitating by stating “*leading* the group – helping them to learn – or *facilitating* – helping them to learn from each other.”¹⁶⁸

Role-based learning also lends itself well into integration with problem based learning. By introducing students to an environment that is modeled on what will be found when they enter the professional workforce the problems given to the students take on an added sense of realism. By giving students specific roles within a team environment to solve broadly defined problems the students are challenged to act like professional engineering problem solvers. Using role-based learning allows the student to fully participate in the practices of a given discipline.^{169,170} The risk associated with a student or group of students not achieving a desired goal is minimized while their perceived risk of not accomplishing a given task is still kept at a high level. The students are therefore allowed to work as an engineering team while still in an academic environment. By being immersed in a professional environment while still being in an academic setting students learn to speak the language of their profession in a safe environment.

9.3 Technology Utilization

Taking advantage of appropriate technology, instructors can introduce real-world problems into the curriculum. When used appropriately multimedia can become a tool to aid in teaching engineering principles. According to Mayer, “multimedia is a sense-making activity in which the learner seeks to build a coherent mental representation from the presented material.”¹⁷¹ It then becomes the instructor’s job to aid the student in the sense-making. By using a motion based flight simulator maintained by Virginia Tech’s Department of Aerospace and Ocean Engineering a complex multimedia presentation of material is presented to the students. The flight simulator has already been used to augment the traditional curriculum in the department on both the undergraduate and graduate level.¹⁷² An expansion of the department’s curriculum to include the “Flight Test Techniques” course created a chance to create a non-traditional learning environment for teaching aerospace engineering concepts. Using a student teaming approach to create an artificial flight test environment similar to that found at a government flight testing facility, the instructors were able to move beyond basic course instruction and classic textbook problems. Key to creating this environment was the use of a realistic flight simulator that is much more capable of approximating flight than a commercially available desktop flight simulation.

9.3.1 Student Immersion

Often examples of problem based and role based learning are engineering design classes where students are asked to use concepts from other courses to solve a specific problem. One failing in trying to transform a classroom environment into a design environment is that the students still perceive that they are in the classroom. The reason is because the proper environment is not set by the instructor. The reasons can range from an inability to make assignments beyond analysis, to not having the proper resources to go beyond analysis, to instructor ignorance. Many senior student design competitions result in only a paper study without students have the opportunity to do hands on work. This leads to an inability to reach all four learning styles as well as the students thinking of the class as just another setting to generate a lab report. By using assignments where students

are required to do more than just analysis, but to actually perform a task set in a properly estimated “real world” environment student perceived risk to the students goes beyond missing a question on the next test and elevates the urgency to learn a skill taught in the course.

9.3.2 Facility

The facility used to teach this course is the same piloted flight simulator laboratory that was used to conduct the nonlinear flying qualities research found in Chapter 8. A detailed description of the simulator and instrumentation can be found in Section 8.2.3. One issue that must be addressed in the use of a simulator is its ability to approximate reality well enough to frame problems posed to students. Approximations and simulations can not encompass an entire experience as well as the real thing. An aircraft simulation is nothing more than an approximation of a real aircraft. This approximation provides both positive and negative impacts that must be weighed to ensure that the use of a simulator is relevant. As computers have increased in complexity and capability aircraft simulators have been able to model the flight of a real aircraft with increasing accuracy. The use of simulators in approximating an aircraft flight should be targeted to areas of their strength, while avoiding areas where simulators do not give accurate representation of aircraft flight. Simulators do not provide the full acceleration cues that are experienced in aircraft flight. Simulators provide only a limited visual perspective as compared to flying in the “real world.” On the other hand, aircraft require extensive maintenance and would not always be available for student use during the course of a semester. A significant detractor in allowing student access to real aircraft is the purchase of liability insurance. Only licensed pilots are legally allowed to pilot aircraft, whereas in a simulator students can be quickly trained to fulfill the position of test pilot. Like an aircraft, a simulator requires large initial investment to acquire the facility, but unlike an aircraft the maintenance and operational costs are much less. Another advantage to using the simulator is that the environment for the simulated aircraft fly can be tightly controlled. Flights are not cancelled by bad weather, and uncertainty in measurements can be tightly controlled so that uncertainties can be introduced or

removed depending on the concepts to be emphasized. While simulators may not be able to fully reproduce an aircraft flight experience, they do pose an ideal setting for basic instruction of aircraft flight.

9.4 Classroom Implementation

The Flight Test Techniques class is designed to present real-world flight testing problems to teams of students performing in roles that can be found on a flight test team working on real aircraft. Instead of using a formal text book, the class uses reference documents that are used in real aircraft flight test. The role of the instructors change as the course progresses. At the beginning of the course the instructors give very specific problems to the flight test teams of students. As the course progresses and the teams mature the instructors transition to a role of facilitators presenting the teams with more open-ended problems culminating with the test teams designing and performing their own flight tests.

9.4.1 Course Goals and Objectives

The course goals can be divided into learning goals specific to aerospace engineering and goals specific to growth in general engineering practice. The high level goals of the course related to aerospace engineering are threefold: namely to reinforce concepts taught in aircraft performance and stability and control classes, expose students to flight testing by reproducing the flight test environment in a classroom setting, and teach students flight test techniques based on currently used manuals in government evaluation of aircraft to prepare them for careers on flight test teams. By the end of the course, each student should be able to:¹⁵⁸

1. Apply concepts taught in aircraft performance and stability and control classes.
2. Explain why different aircraft feature different handling characteristics.
3. Describe, based upon hands-on experience, the connection between aircraft flight theory and aircraft flight.

4. List key factors used to define aircraft performance and stability and control.
5. Apply theory from classrooms into a 'big picture' aircraft perspective, or from a systems perspective.
6. Describe standard flight test processes and procedures for safety.
7. Outline a procedure for gathering results from stated requirements.
8. Identify challenges unique to the roll of test pilot based upon personal experience in the simulator cockpit.
9. Identify challenges unique to the position of test conductor, running a flight test as an engineer.
10. Interpret gathered flight test data, and present that data in a standard, technical form.
11. Explain flight test techniques based on currently used manuals in government evaluation of aircraft.
12. Classify both qualitative and quantitative aircraft characteristics in terms of MIL-F-8785C
13. Calculate level performance data based on student-collected 'flight' data as described in the US Navy Performance Manual.¹⁷³
14. Calculate excess power performance data based on student-collected 'flight' data as described in the US Navy Performance Manual.¹⁷³
15. Calculate sawtooth climb performance data based on student-collected 'flight' data as described in the US Navy Performance Manual.¹⁷³
16. Calculate climb schedules based on student-collected 'flight' data as described in the US Navy Performance Manual.¹⁷³
17. Evaluate longitudinal flying qualities based on student-collected 'flight' data as described in the US Navy Stability and Control Manual.¹⁷⁴

18. Evaluate lateral-directional flying qualities based on student-collected ‘flight’ data as described in the US Navy Stability and Control Manual.¹⁷⁴
19. Design a flight test synthesizing results from prior flight tests.
20. Identify potential safety hazards for a flight test.
21. Classify the risk inherent to a flight test.
22. Evaluate options/opportunities to mitigate risks.
23. Justify choice of acceptability of risk.

The goals of the course related to growth in general engineering practice are threefold as well: foster a deep conceptual understanding of aerospace engineering principles, foster student competence and confidence in their knowledge of aerospace engineering so that their knowledge is readily maintained “after taking the test,” and give students a hands-on apprenticeship in engineering prior to leaving school.

These objectives were developed to address the six levels of Bloom’s taxonomy in the cognitive domain; knowledge, comprehension, application, analysis, synthesis, and evaluation.^{175,176} An emphasis is placed upon the higher level objectives of analysis, synthesis, and evaluation as they are oft neglected in undergraduate education yet are an important component in developing students and future engineers.^{177,178} Due to the laboratory nature of the course, performance objectives consider both procedural (*e.g.* describe standard flight test processes and procedures for safety) and product outcomes (*e.g.* design a flight test synthesizing results from prior flight tests).¹⁷⁹ Through tasks such as developing procedural knowledge, laboratory skills (including, but in no way limited to, the act of piloting the simulator), and writing laboratory reports, students are able to develop their skill set in the cognitive, psychomotor, and affective domains.¹⁷⁹

9.4.2 Course Organization

The Flight Test Techniques class met twice weekly for 75 minute sessions. This time was split into a two week rotation, where the first week was spent in classroom instruction and the second week was spent in simulation testing. Two optional laboratory times of one hour and fifteen minutes each were established for each test team to work with the simulator as they desired. The twenty student class was divided into four test teams of five students each. The students grades were based solely on flight test reports that were due one week after a test was performed. With the exception of the first report, used to gauge each individual students report writing capabilities, each report was submitted as a group effort thus requiring the students to work together as a flight test team. Students were given a basic reporting format to follow, and were required to provide percentage of work by each team member on the report.

Each section of the course begins with a specific, complicated, real-world problem to solve. The in-class portions serve to supplement the student's knowledge by addressing procedures and overarching principles required for the flight test.¹⁸⁰ At the start of each laboratory, students are presented with a final task which must be accomplished, such as quantifying aircraft climb performance. They must then use knowledge from prior classes to determine the data required for the flight test.

Lectures are presented to address student questions and to assist with the general formulation of the presented problem. Specifically, the classroom portion of this course was used to revisit students' prior coursework on aircraft performance, equations of motion, basic stability and trim analysis, and energy management. Additionally, flight testing procedures were introduced. After discussing the theory behind the test, a pre-flight briefing for each test was done in class. This pre-flight briefing included the test cards to be used (sample page of test cards given in Figure 9.1, reporting objectives, safety requirements, and any special procedures required for the test. The exception to this pattern is during flight tests 4 and 5, where students must develop their own test cards and present a flight safety board (FSB) briefing.

After classroom instruction, students proceed to the simulator to conduct the flight test, and reduce the data for their team-generated topical report. The students' time spent in the Flight Simula-

 <p>VPISU Flight Simulation Lab</p>	<p>AOE 4984 Flight Test Techniques Lab 1: Facility Fam</p>																																
<p>Pilot:</p>	<p>FTE: _____ Test Conductor: _____ Date: _____</p>																																
<p>Aircraft: HOKIE 1</p>	<p>G/W: 37150 lbs</p> <p>Data Location</p>																																
<p>Conditions -- various, see below</p>																																	
<p>VIAS</p>	<table border="1" style="width: 100%; border-collapse: collapse;"> <tr> <td style="width: 25%;">Altitude</td> <td style="width: 25%;">OAT</td> <td style="width: 25%;">aoa</td> <td style="width: 25%;"></td> </tr> </table>	Altitude	OAT	aoa																													
Altitude	OAT	aoa																															
<p>Restrictions</p>																																	
<table border="1" style="width: 100%; border-collapse: collapse;"> <tr> <td style="width: 25%;">Accel: g's</td> <td style="width: 25%;">VIAS</td> <td style="width: 25%;">Ceiling</td> <td style="width: 25%;">Deck</td> </tr> <tr> <td>6 g's</td> <td>1000 KTS</td> <td>30000 FT</td> <td>4000 FT</td> </tr> </table>	Accel: g's	VIAS	Ceiling	Deck	6 g's	1000 KTS	30000 FT	4000 FT																									
Accel: g's	VIAS	Ceiling	Deck																														
6 g's	1000 KTS	30000 FT	4000 FT																														
<p>Test Summary</p>																																	
<table border="1" style="width: 100%; border-collapse: collapse;"> <tr> <th style="width: 10%;">#</th> <th style="width: 40%;">Event</th> <th style="width: 20%;">Condition</th> <th style="width: 30%;">Notes</th> </tr> <tr> <td>1.0</td> <td>Preflight Check</td> <td>On ground</td> <td></td> </tr> <tr> <td>2.0</td> <td>T/O and Climb Out</td> <td>DNE 250 KIAS</td> <td></td> </tr> <tr> <td>3.0</td> <td>Capture H / HDG</td> <td>H 20000 300 KIAS</td> <td></td> </tr> <tr> <td>4.0</td> <td>Aircraft Response</td> <td>H 20000 300 KIAS</td> <td></td> </tr> <tr> <td>5.0</td> <td>Capture H / HDG</td> <td>H 10000 300 KIAS</td> <td></td> </tr> <tr> <td>6.0</td> <td>Drag Devices</td> <td>H 10000 200 KIAS</td> <td></td> </tr> <tr> <td>7.0</td> <td>RTB</td> <td></td> <td>Optional</td> </tr> </table>	#	Event	Condition	Notes	1.0	Preflight Check	On ground		2.0	T/O and Climb Out	DNE 250 KIAS		3.0	Capture H / HDG	H 20000 300 KIAS		4.0	Aircraft Response	H 20000 300 KIAS		5.0	Capture H / HDG	H 10000 300 KIAS		6.0	Drag Devices	H 10000 200 KIAS		7.0	RTB		Optional	
#	Event	Condition	Notes																														
1.0	Preflight Check	On ground																															
2.0	T/O and Climb Out	DNE 250 KIAS																															
3.0	Capture H / HDG	H 20000 300 KIAS																															
4.0	Aircraft Response	H 20000 300 KIAS																															
5.0	Capture H / HDG	H 10000 300 KIAS																															
6.0	Drag Devices	H 10000 200 KIAS																															
7.0	RTB		Optional																														

<p>Low Risk</p>	<p>Test Point 1.0 Preflight Check</p>
<p>Set Parking Break</p>	<p>1.1 Com Check and Team Readiness</p> <ul style="list-style-type: none"> • Poll Data Room Go/No Go for Test • Poll FTE Go/No Go for Test • Poll Pilot Go/No Go for Test
	<p>1.2 Control Surface Check</p> <ul style="list-style-type: none"> • Left Stick FULL • Right Stick FULL • Aft Stick FULL • Forward Stick FULL • Left Rudder FULL • Right Rudder FULL
	<p>1.3 THROTTLE TEST</p> <ul style="list-style-type: none"> • Throttle – MIL • Throttle – FULL AB • Throttle – IDLE
	<p>POLL Go / No Go</p>
	<p>1.4 Aircraft Prep for Flight</p> <ul style="list-style-type: none"> • Set flaps to takeoff position • Gear check • Obtain Clearance for Takeoff Roll
	<p>Unset parking break when ready for takeoff</p>
<p>Low Risk</p>	<p>Low Risk</p>

CCotting 01/25/06 Rev B

CCotting 01/25/06 Rev B

Figure 9.1: First page of Laboratory 1 flight test cards.

tion Laboratory was split into two defined periods. The first period was listed as a practice session for each flight test group. Each group was given a total of 3 hours a week simulator time that could be used for anything they wished, from basic aircraft familiarization, to night carrier landings, to rehearsing the next flight test. This time was not required for class participation, but was made available to the students so that they could get the most exposure possible to the flight simulator. The second period was during the official course time, and was when their actual flight test was performed. During this time each team reported to the flight simulation lab for their assigned test. This time was highly structured, and student participation was required. While roll was not taken during this time, each test was designed to require a full test team. In order for the data to be taken for a given test report a full team was required, and students learned quickly to work together to ensure all were present and engaged during testing.

9.4.3 Flight Testing Positions

Specific responsibilities were assigned to different stations during the flight test. The flight test tasks were broken down by position as described in Figure 9.2. While not required to do so, students were encouraged to rotate positions so that they could experience all aspects of flight testing during the semester.

9.4.3.1 Test Pilot

This position requires great skill in piloting the aircraft. The test pilot must be capable of doing much more than just fly the aircraft. He must be capable of flying the precise maneuvers required by the flight test cards to generate the necessary data for the test. At the beginning of the semester, the instructor would demonstrate the first half of the test, and then help the student pilot through the maneuvers during the second half of the test. As the semester progressed and student proficiency improved, the students assumed the full role of test pilot enabling them to fly entire test missions. It should be noted that several students in the course had experience as private pilots, and quickly learned this position. Interestingly enough however, other students in the class had considerable

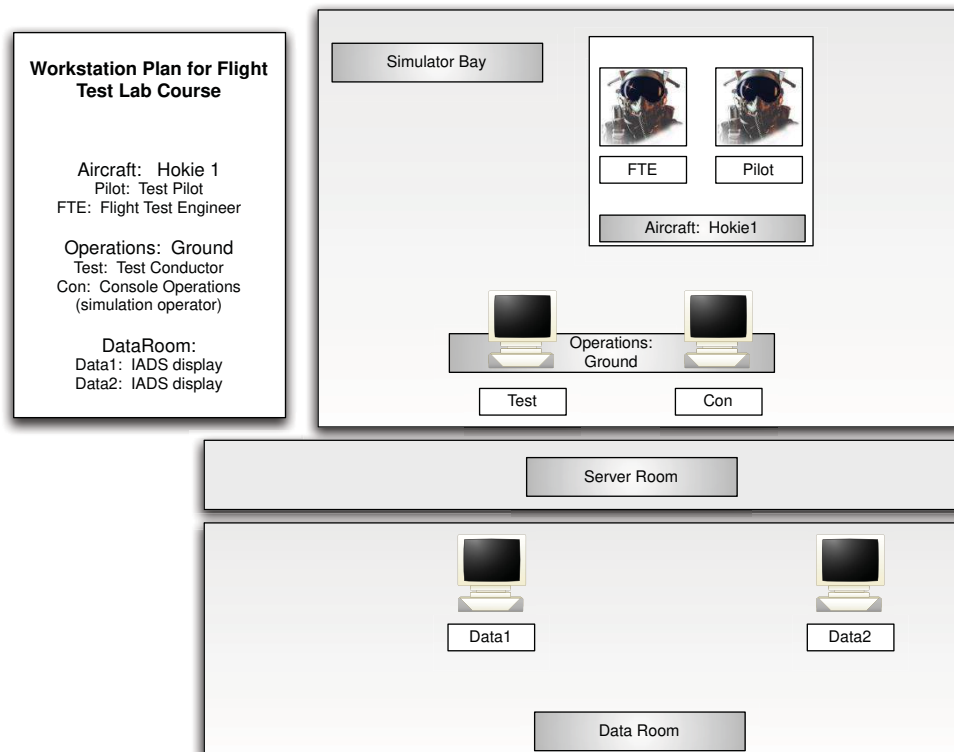

Figure 9.2: Illustration of flight test tasks/stations.

video game flight simulator experience, and also quickly learned this position.

9.4.3.2 Flight Test Engineer (FTE)

For this course the position of Flight Test Engineer was defined as the person in the right seat of the cockpit. While sitting in this position, the FTE would have access to data displays that could not be shown to the pilot. The FTE would work with the pilot to ensure the test criteria were being met by reading off instrumentation and augmenting the pilot's information during the test. The FTE also served as a second set of eyes and ears in the cockpit during the test, and would comment on pilot workload and any anomalies during the test.

9.4.3.3 Test Conductor

The test conductor was positioned at the operation console for the simulation. The test conductor was responsible for the overall test, and would direct the test from the test cards. He would also mark the time the events occurred during the test, so that during data playback in post-test analysis the proper timeline for data analysis could be identified.

9.4.3.4 Discipline Engineer

While for this course specific discipline engineers are not identified, students monitoring the test data were referred to as discipline engineers. They took data to fill out test cards, monitored parameters during the test, and commented on the test margins to ensure the aircraft remained within desired parameters.

9.4.4 Teaching and Student Participation

Flight testing relies on multiple individuals with various talents working together as a team to be successful. Understanding each role and how it relates to the team is crucial to effective team performance. The Flight Test Techniques course reinforces this concept by grouping students into flight test teams of five students. Each test team must prepare, execute, and report on the test as a

team. Further, each student is given an opportunity to fill various roles on the team. By rotating team positions the student can find areas of strength and areas of needed improvement in their skill set. Allowing students to experience each team position also gives a sense of appreciation for each team positions' responsibilities. When students complete this course, they have a basic understanding of the nature of each position in a flight test team and a good idea of where they would best fit into a flight test team when they enter the workforce.

A unique aspect of the Flight Test Techniques course is that it accommodates a variety of learning styles. According to Fleming and Mills¹⁸¹ students address the learning of information in one of four ways; Visual, Aural, Read/Write, and Kinesthetic. The Flight Test Techniques course presents its topics to the students in all four ways, maximizing the chance that a student has to learn the material. Each topic is presented in a classroom lecture and pre-flight briefing where the theory and technical background for the test is presented, representing the aural learning style. Students are given text and reference information regarding the topic, aiding in their preparation for the flight test, and addressing the read/write learning style. During the test data is displayed in a visual format that the students must watch, and judge as to its quality, allowing the exercising of the visual learning style. The test also allows the students to see first hand how their actions to the aircraft impact the results of the test, giving them an experiential learning environment, accommodating a kinesthetic learning style. Finally, a report is written at the end of the test allowing the students to demonstrate their understanding of the material presented, further reinforcing the read/write learning style.

To appeal to and retain students from diverse backgrounds, this course aims to serve all psychological and learning types. Typical engineering curricula teach toward intuitive students with the majority of faculty falling into the Myers-Briggs category of intuitors.¹⁸² However, most engineering students are sensors.¹⁷⁶ Thus Wankat and Oreovicz¹⁷⁶ suggest designing courses to appeal to sensors and serial learners with global summaries presented at the end of each class thus serving both learning styles. By designing the course to serve both learning types, requiring both recall of prior information and open hypothesis, stressing both how to evaluate data and the possibilities that arise from the data, and requiring team-work in the completion of flight tests and reports, diversity

in the attraction of students with varied learning approaches and backgrounds is fostered.

9.4.5 Using the Proper Vocabulary

The vocabulary of aerospace engineering includes contributions from academia, technicians, and pilots, as well as working engineers to create a mixture of terms that can often be confusing or intimidating to an engineer directly out of school. For example, academia typically only uses SI units, whereas the US aircraft industry as well as international flight regulations only use English units. While students become familiar with velocity in meters per second, they will be asked to relate to others in industry that are familiar with nautical miles per hour (knots). Aircraft also report velocities in equivalent airspeed, calibrated airspeed, true airspeed, ground reference speed, measured mach number, true mach number to name a few examples. In typical undergraduate curriculums only one velocity is used to reference an aircraft, and the distinction between the different values is not always made clear. It is also important that students begin to recognize synonyms in the vocabulary such as angle of attack, and its typically referenced variable name " α ." Pilots will often communicate in short bursts of very technical jargon in order to convey a qualitative analysis of their situation, and it is the job of the aerospace engineer to translate that jargon into a form that can be used for quantitative analysis. By immersing the students into a world where these terms are used on a regular basis, and then expecting them to communicate using those terms, the students quickly become conversant in a vocabulary that they would not have been exposed to during their undergraduate education.

9.4.6 Using Reference Books Instead of Textbooks

This class uses industry reference documents and asks students to reuse textbooks from their previous classes. Taking this approach exposes students to documents used in industry. This approach also teaches students how to search their personal libraries for information. Government references used in the course include *U.S. Naval Test Pilot School Flight Test Manual, Fixed Wing Stability and Control: Theory and Flight Test Techniques*,¹⁷⁴ *U.S. Naval Test Pilot School Flight Test Manual*,

Fixed Wing Performance,¹⁷³ MIL-SPEC-8785C,¹⁸³ and NASA TN D-5153.²³ Students are asked to review texts and course notes from their courses in aircraft performance, and aircraft dynamics and control. The course structure is centered on the fulfilling eight laboratory assignments or “flight tests” with each assignment building on material presented from previous tests. Instead of following a topical survey similarly to how most engineering texts are organized, the students follow a simulated aircraft through a series of flight tests as if the aircraft was a new aircraft going through an evaluation / test program. Instead of using classroom time to teach concepts learned from previous classes, the classroom lectures are spent doing a quick review of concepts to be used for each flight test followed by testing techniques that are used to test for different aircraft characteristics. Students are required to review on their own basic aircraft concepts found in their text books.

9.4.7 Team Building

Course progression is designed to allow teams to build up to a point of solving problems presented by the instructors with minimal intervention. Since students require basic instruction into flight testing at the beginning of the semester the first assigned lab is labeled as a familiarization with the aircraft and basic testing techniques. Test teams are formed, but kept under tight supervision with an instructor taking the lead as a test conductor. Students must rely on each other to perform and analyze data for the first test, but must write individual reports. The next lab assignment the team of students is given formal instruction as to the testing techniques but is given full autonomy in conducting the test. This lab is also the first group lab report where the entire group must rely on each member to contribute to the final report. Each member collects part of the data-set during the flight test, and the team as a whole must assemble the pieces of data taken in order to form a full report. A third lab is then conducted under the same rules, where instructors give specific instruction on how to conduct the lab, but students are given full autonomy to conduct the test and analyze the data. During this time the students begin to understand the strengths and weaknesses of each team member, and begin to get comfortable conducting the flight tests. The fourth lab in the series builds directly from the third lab data and its concepts. Students are given a tutorial in

how to analyze the data for aircraft climb performance, and then given the task of predicting the aircraft's climb performance and then testing their predictions. The students are required to create their own flight test plan and then brief the plan before it is executed to a Flight Safety Board (FSB) which consists of the instructors. Included in the plans are hazard analysis and mitigation as well as a detailed flight test plan. The flight test teams must create this briefing, and are quizzed on each portion to ensure all students were equal participants in creating the plans. Upon FSB approval the team conducts the flight test. They must then must analyze their data and create a group flight test report. The fifth lab is designed to take data from the second and fourth labs to create a minimum fuel flight profile for an aircraft to follow to achieve a landing on dry land after an aborted air craft carrier landing. The students must design the flight profile based on the data from their previous flight tests. They are then required to present their plan at another FSB briefing. After FSB approval the teams conduct their flight test and analyze their data to create another group flight test report. The final two labs transition to a subject known as flying qualities analysis. The students are once again given instruction as to proper test techniques, but this in these labs multiple students from the test team must fly the mission and results are based off of the pilot's opinion of the aircraft's flying qualities. Students must assemble possible conflicting results and come to a consensus on a collection of qualitative and quantitative data. By the end of the semester the students have not only applied lessons taught in the classroom, but they have used that information to create solutions to open ended problems presented to them by their instructors.

9.4.8 Evaluation of Students; More Than Just Grades

The formal grading for the semester is based on the grades given for each lab report. While the grading may seem very simplistic, the work required to generate the lab report requires complex interactions between the students. The students must work together to compile the data that each student records into a full data-set. The simulator allows the instructors to create a lab so that there is a predetermined "right answer," but the right answer is not required for students to perform well on a lab report. Instead of stressing a right answer the grading of the lab reports stresses the student's

ability to justify the results provided. A wrong answer that is well justified with shortcomings to the methods used and a possible solution for correcting the data receives just as much credit as a right answer that describes how the data was correctly taken. A right answer that does not detail the methods used in the flight test and explain the methods can be given as poor a grade as an incorrect answer that is poorly justified. Students are informed at the beginning of the semester that the data they take will build upon itself over the course of the semester, and that incorrect data will skew results not just for one lab, but for the entire semester. This adds extra motivation to ensuring that the team members perform their duties and that all work is understood fully by each team member. In the event that erroneous data is generated and the team can describe the error, and how to correct the procedure the team can be allowed to rerun the test and generate better quality data, but only after the team has come to a conclusion as to how to correct their work.

9.5 Evaluation of Objectives

The evaluation of the course goals and objectives as stated in Section 9.4.1 was done with grading of student reports, and the use of anonymous surveys. The surveys were given to the students at the end of the course, to the students after they had entered the workplace, and to the student's employers. The results of these surveys are collected in Appendix A.

The first high level goal of reinforcing concepts taught in the aircraft performance and stability and control classes was targeted first by assuring the topics found in first eighteen specific course goals were adequately addressed in the lesson planning. This included readdressing issues during class time when a student report showed deficiencies in a particular area. The surveys then showed that the concepts were reinforced. Questions 6 and 7 in Section A.1 listed below

This class has improved my overall understanding of aerospace engineering.

Strongly Agree ¹ ² ³ ⁴ ⁵ Strongly Disagree

Average Response: 1.415

I better understand the theories and concepts taught in my other classes based on the topics taught in this course.

Strongly Agree Strongly Disagree

Average Response: 1.735

show that the students felt strongly that their knowledge of concepts taught in other classes was enhanced by this course. Further comments 2, 4, 5, and 7 in Section A.1 shown below

- “Actually applying knowledge learned in other classes”
- “It provided a new conduit through which to demonstrate the material taught through the AE curriculum”
- “Helps you see how everything from previous courses comes together.”
- “It reinforced topics learned in other courses and gave those concepts real-world meaning.”

reinforce the perception that students were able to enhance their understanding of topics from previous courses. The post graduation survey further enforced the accomplishment of the goal. In Section A.2 questions 3 and 8 below

My understanding of basic aerospace engineering principals was enhanced by taking AOE4984 Flight Test Techniques.

Strongly Agree Strongly Disagree

Average Response: 1.35

The use of a flight simulator enhanced my understanding of aerospace engineering concepts.

Strongly Agree Strongly Disagree

Average Response: 1.35

show that aerospace principles were reinforced with the course, as well as comments 2, 9, 10, 13, and 15 shown below.

- “The flight simulator provided a great hands-on experience to reinforce concepts learned in lecture. An hour flying the simulator experiencing the different modes of stability was comparable in value to weeks of lecture. Being able to calculate a max range climb/cruise/descent profile in an effort to make it to an airstrip, and then successfully fly the profile with a limited amount of fuel was much better than any scenario that could be presented in a Performance class.”
- “I think it was the most important class that I took at Virginia Tech. It exposed me to the type of job I wanted as well as enabling me to get a better grasp on the concepts that I had spent the last 3 years of study learning about.”
- “The flight test class made for an excellent capstone to my engineering degree and allowed me to put everything I had learned into practice and apply to practical applications. It was the first class that made me honestly feel like I was in the right major, which is a shame considering it was taken in my last semester. ”
- “Flight test techniques was without a doubt my favorite class I took in the aerospace curriculum. It helped reinforce the principles learned in other classes and gave me the connection to the real world that I needed. Too much of the aerospace curriculum is abstract, flight test was much more realistic. ”
- “I think flight simulator assignments should be incorporated into intro to aerospace engineering and in aircraft flight dynamic courses... I can honestly say I didn’t understand several aerospace principals until I was exposed to an actual aircraft. I feel that it is highly unlikely that the department can expose students to real aircraft, but I think a simulator could help fill the gap.”

The second high level goal was to expose students to flight testing by reproducing the flight test

environment in the classroom. This was done by first making sure the instructors could speak in an authoritative fashion about flight testing. The labs were arranged so that students would be using industry standard software for analysis (IADS[®]) as well as flight test cards that are representative of what would be used in industry. The labs were all initiated with pre-flight briefings formatted after typical flight test briefings, and they were completed with flight test reports that were similar to those that would be found in industry. The self assessment surveys attest to the realism of the class. Specifically comments 1, 2, and 9 in Section A.1 below

- “This class actually covered material and procedures required in the Real World, not just the theory behind it.”
- “Actually applying knowledge learned in other classes”
- “I liked that the course required us to come up with our own flight test cards. It really made us think about what we were doing.”

show the students understanding the relevance of the class. In Section A.2 the result from survey question 1 states that 6 of the respondents were currently employed in flight testing. Comments 3 and 16 in Section A.2 and shown below

- “Looking back on the class, everything in the real life flight test field is exactly like the class.”
- “I’ve been to a few performance flight tests and they are exactly how I remember them from the flight test course. It wasn’t until I went to the flight tests that I truly appreciated how close the flight test class was to the real world. ”

further illustrate from students that have gone to flight testing that the proper flight test environment was created in the class.

The third high level goal was to teach students flight test techniques based on manuals used in government evaluation of aircraft. The two primary texts of the course were *U.S. Naval Test Pilot School Flight Test Manual, Fixed Wing Performance*¹⁷³ and *U.S. Naval Test Pilot School Flight Test*

*Manual, Fixed Wing Stability and Control: Theory and Flight Test Techniques.*¹⁷⁴ These two manuals were used in conjunction with the student’s texts from previous courses to show how their course texts could be used as a reference when applying techniques specified in a professional manual. Evidence of a student understanding the importance of this can be found in Section A.1 comment 4 also seen below.

“It provided a new conduit through which to demonstrate the material taught through the AE curriculum”

Questions 4 and 5 in Section A.2 and questions 3, 4, and 5 in Section A.3 all collected below

My PROCEDURAL understanding of aerospace engineering principals was enhanced by taking AOE4984 Flight Test Techniques.

Strongly Agree ¹ ² ³ ⁴ ⁵ Strongly Disagree

Average Response: 1.94

My CONCEPTUAL understanding of aerospace engineering principals was enhanced by taking AOE4984 Flight Test Techniques.

Strongly Agree ¹ ² ³ ⁴ ⁵ Strongly Disagree

Average Response: 1.47

The AOE4984 graduate has a higher PROCEDURAL understanding of aerospace engineering principals than a typical employee of his tenure.

Strongly Agree ¹ ² ³ ⁴ ⁵ Strongly Disagree

Average Response: 1.67

The AOE4984 graduate has a higher CONCEPTUAL understanding of aerospace engineering principals than a typical employee of his tenure.

Strongly Agree ¹ ² ³ ⁴ ⁵ Strongly Disagree

Average Response: 1.67

New hires working for me are required to have a stronger than average PROCEDURAL understanding of aerospace engineering principals.

Strongly Agree ¹ ² ³ ⁴ ⁵ Strongly Disagree

Average Response: 2.33

show that both procedural as well as conceptual understanding of engineering material was accomplished during the class. The concept of aiding design thinking with divergent thought was evident in the comments 7,8, and 9 made by the students in Section A.1 as seen below.

- “It reinforced topics learned in other courses and gave those concepts real-world meaning.”
- “I feel that this course should be required at the junior or senior level because it brings hands-on, real meaning to all of the theory and number crunching we do in other classes. This was one of the few classes where I actually got to ”do engineering” .”
- “I liked that the course required us to come up with our own flight test cards. It really made us think about what we were doing.”

Addressing the general engineering practice goals, they were primarily targeted with the specific course goals 19 - 23. Deep conceptual understanding of aerospace concepts was evaluated by the response found in Section A.1 comments 5 and 6 listed below

- “Extensive teamwork was required to complete the work required for the mission on the simulator, as well as complete the report. The same type of teamwork is required of me in my current job.”
- “I came to work with a good understanding of the team mentality that is critical to perform my job effectively, and also gave me real life examples of problems that could occur.”

as well as Section A.3 comment 1

“I can’t stress the importance of relevant flight test experience. I go out of my way to find students that have had the VT or [another] flight test class because of the knowledge and experience gained by the students. From the basics of how to develop a test to the specifics of what actually occurs during a flight, the flight test course exposes students to the skill set necessary to excel at [ORG-X]. [ORG-X] has spoken with several universities in the past and encouraged their engineering departments to incorporate a class similar to the VT flight test class. It would be a shame to lose that competitive edge that VT grads have with [ORG-X].”

Student’s knowledge was improved beyond just the final exam and the course as evidenced by the response in Section A.1 comments 10 and 11 seen below,

- “This was one of the most interesting and practical courses I’ve taken. It showed us why we need to know what we are learning.”
- “My favorite course of my 5 years here. I learned more in this class than any other. The first time I was excited to be an engineer.”

as well as Section A.3 comment 2

“The AOE4984 curriculum clearly prepared my employee for the avionic systems work that he was hired for. He came in with surprising breadthwise knowledge and was hungry to dig into the more complex and ambiguous problems our engineers are challenged with in the industry.”

The hands on apprenticeship was accomplished as demonstrated in Section A.2 questions 8 and 9 as well as comments 5 - 10 of that section.

The use of a flight simulator enhanced my understanding of aerospace engineering concepts.

Strongly Agree ¹ ² ³ ⁴ ⁵ Strongly Disagree

Average Response: 1.35

The teaming arrangements of AOE4984 Flight Test Techniques prepared me for my current work environment.

Strongly Agree ¹ ² ³ ⁴ ⁵ Strongly Disagree

Average Response: 1.88

- “Extensive teamwork was required to complete the work required for the mission on the simulator, as well as complete the report. The same type of teamwork is required of me in my current job.”
- “I came to work with a good understanding of the team mentality that is critical to perform my job effectively, and also gave me real life examples of problems that could occur.”
- “I work with teams of various people almost everyday at my job. Without working together not much would get done. Time working on teams in college helps prepare for this.”

- “I currently work in a team environment. Being able to communicate and work with others with a variety of personality traits is difficult. The team arrangement in this class prepared me for my current work environment.”
- “I think it was the most important class that I took at Virginia Tech. It exposed me to the type of job I wanted as well as enabling me to get a better grasp on the concepts that I had spent the last 3 years of study learning about.”
- “The flight test class made for an excellent capstone to my engineering degree and allowed me to put everything I had learned into practice and apply to practical applications. It was the first class that made me honestly feel like I was in the right major, which is a shame considering it was taken in my last semester. ”

Section A.3 comment 3 also reinforced the concept of an apprenticeship environment during the course.

“This gives the new hire a leg up in bridging the gap between theory and practice. This has taken some load off of me and our senior leads.”

One interesting conclusion from the surveys conducted is that high impact can be made in deep understanding of a subject without causing extra work for students. In Section A.1 questions 1 and 2 seen below

This class required _____ time than my other classes.

Considerably More 1 2 3 4 5 Considerably Less

Average Response: 2.6

I learned _____ than I expected from this class.

Considerably More 1 2 3 4 5 Considerably Less

Average Response: 1.77

the students rated the flight test course as requiring no more work than any of their other courses, but at the same time stated that they received more benefit from the class than most of their other

traditionally taught courses. The blending of problem based learning with cooperative learning and role based learning creates a very powerful teaching strategy as shown by the results of surveys conducted. The realism of the course was strengthened by the two instructors having first hand knowledge of the flight testing environment. This lends credence to the statement from the *Engineer of 2020*⁷⁸ calling for educators to have industry experience.

An added benefit to using cooperative learning is that students foster teamwork skills that can be used outside of the narrow focus of flight testing as offered in the course. Although Section A.2 question 1 states that most students that responded were not a part of flight testing field the teaming skills taught in the course were highly valued as found in Section A.2 question 9, and comments 5-8.

The teaming arrangements of AOE4984 Flight Test Techniques prepared me for my current work environment.

Strongly Agree ¹ ² ³ ⁴ ⁵ Strongly Disagree

Average Response: 1.88

- “Extensive teamwork was required to complete the work required for the mission on the simulator, as well as complete the report. The same type of teamwork is required of me in my current job.”
- “I came to work with a good understanding of the team mentality that is critical to perform my job effectively, and also gave me real life examples of problems that could occur.”
- “I work with teams of various people almost everyday at my job. Without working together not much would get done. Time working on teams in college helps prepare for this.”
- “I currently work in a team environment. Being able to communicate and work

with others with a variety of personality traits is difficult. The team arrangement in this class prepared me for my current work environment.”

The survey in Section A.2 also suggested that both conceptual as well as procedural understanding in aerospace engineering principles were enhanced. By having a practical application of previously studied skills one would expect that conceptual principles would receive greater benefit, but according to the participants both were almost equally enhanced. It is also interesting to note the balance with which employers value conceptual as well as procedural understanding as found in Section A.3.

9.6 Conclusions

The teaching experiment with the flight test techniques course was successful in motivating students and having them learn from themselves while being immersed in a realistic environment. Courses such as this one allow students to apply the scientific knowledge that have learned from previous classes and begin to gain confidence in their understanding of the principles. This gain in confidence and conceptual understanding is what allows students to be able to “speak airplane” in a competent manner. While many students desire application of the engineering skills taught in standard courses, the context of the application is just as important as application itself. By combining pedagogues in a way that closely mimicked a real life scenario the flight test techniques course was able to foster the learning and remembering of concepts that were useful in both the student’s and their employer’s opinion. With courses designed in this manner significant gains in student understanding can be achieved and measured.

Chapter 10

Conclusions and Recommendations

THIS work has highlighted several areas of research in flight mechanics and flying qualities in an effort to raise awareness of open issues in flight mechanics, and to promote future work in this field. The growing use of UAVs in particular has necessitated a “fresh look” at existing flying qualities criteria that were originally developed for piloted applications. In addition, the desire to use nonlinear control systems in aircraft for failure reconfiguration in moment and commands has resulted in significant research in control design, and a need now arises to evaluate those controllers. Finally hands on instruction in flight mechanics education presents unique challenges that can make access to piloted aircraft difficult and often prohibitive. Work has been done to overcome some of these challenges by using UAVs in classroom instruction^{128,129,184} to provide experiential access to aircraft in flight mechanics education. Although UAVs overcome some of these challenges, they still do not yield the first hand experience of flight as experienced with piloted aircraft.

A new method to classify UAVs has been presented that allows for a more appropriate grouping of vehicles for flying qualities evaluation. Current methods used by the military focus on gross takeoff weight, and do not allow for the operational envelope of the vehicle when the classification is made. Borrowing from some of the concepts used to classify piloted aircraft, a new classification method has been proposed using both Reynold’s number and gross takeoff weight. Instead of

picking aircraft arbitrarily by size, this method allows flying qualities criteria to be evaluated using aircraft from representative groups with parameters that directly relate to the forces and moments that affect flight. This classification could be expanded, however. Future work to include maximum load factor for maneuvering UAVs would enhance the proposed classification system for UAVs. A similar classification method is also needed for sensors that are used on UAVs. For camera related sensors the gimbal dynamics and focusing dynamics, as well as field of view would possibly allow cameras to be classified in a similar manner to aircraft. While this data has been difficult to obtain, the ultimate goal of integrating payloads and aircraft to form a UAV flying qualities standard must have both aircraft and sensors classified.

The UAV flying qualities criteria presented in this work are breaking new ground in flying qualities analysis. They should be considered the first steps to creating an adopted standard between government and industry partners. The simplified pitch criterion offers the benefit of using simple analysis techniques to analyze an aircraft and sensor system that can be characterized by a transfer function. It treats the mixed aircraft and sensor dynamics as a complete system whose ultimate goal is to follow a desired pointing vector towards a target. In this criterion the integrated aircraft and sensor dynamics are measured to ensure a stable platform for the sensor to perform its mission effectively. The criterion with winds, or “ χ criterion” goes further than the simplified pitch criterion and measures the interaction of the aircraft’s phugoid and short period in performing the mission task. Of particular interest is the turbulence dynamics that can not be rejected by sensor stabilization. Coupled together these two criteria give the UAV designer the ability to measure the total UAV and sensor system’s ability to achieve a desired task. Future work is needed in creating a catalogue of MTEs. Once these MTEs are created appropriate boundaries can be drawn for achieving different levels of flying qualities. Once these boundaries have been defined, flight test maneuvers can be designed for the flight test and evaluation of UAV flying qualities.

Nonlinear flight control systems have seen considerable research and advancement toward imple-

mentation on both piloted and unpiloted aircraft. Their evaluation for flying qualities testing must also be considered. A \mathcal{L}_1 adaptive controller has been evaluated for a pitch tracking task in a piloted simulation. This marks the first time that this type of controller has had a piloted evaluation. The successful recovery of good flying qualities by the adaptive controller for a degraded system shows promise for future implementation of this controller for piloted flight testing. However, just as flying qualities standards must evolve to support UAV applications, flying qualities criteria must also be developed to test nonlinear control systems.

The new challenges in flying qualities analysis require that future generations of engineers have hands-on training in aircraft flight mechanics in order to further develop and apply future flying qualities criteria to the next generation of aircraft. Engineering educators have been challenged to rise to new levels of effectiveness in teaching tomorrow's engineers. The subject of atmospheric flight mechanics is a difficult subject to apply hands on teaching since the cost and risk of operating piloted aircraft can be prohibitive. The use of a piloted flight simulator to augment flight mechanics curriculum was demonstrated with great success. By combining problem based learning and role based learning in a learner centered environment students were challenged to learn while doing, fostering deep learning of flight mechanics concepts. The flight simulator served as a key catalyst in creating a relevant environment where students could explore and learn key flight mechanics principles. It is unfortunate that very few schools have a resource of this caliber available to aid in flight mechanics instruction.

With the advent of new aircraft control systems, and new paradigms of aircraft such as UAVs flight mechanics research has renewed relevance. UAVs today are gaining prominence just as piloted systems gained prominence during the 1950's when the first piloted flying qualities criteria were developed. Continued work is needed to classify UAV payloads, catalogue MTEs in order to develop a systematic approach to creating flying qualities criteria, and in the development of lateral-directional flying qualities criteria. The application of flying qualities criteria to nonlinear control

systems for both piloted and unpiloted systems must also continue to be explored.

Bibliography

- [1] B. Etkin, *Dynamics of Flight, Stability and Control*. New York, NY: John Wiley and Sons, second ed., 1982.
- [2] F. W. Lancaster, *Aerodnetics*. London, England: A. Constable & Company Ltd., 1908.
- [3] G. H. Bryan and W. E. Williams, “The Longitudinal Stability of Aerial Gliders,” *Proceedings of the Royal Society of London*, Vol. 73, The Royal Society, January 7 1904, pp. 100–116.
- [4] G. H. Bryan, *Stability in Aviation*. London, England: Macmillian Co., 1911.
- [5] anon, *U.S. Military Specification MIL-F-8785C*. Department of Defense, 5 November 1980.
- [6] C. R. Chalk, T. P. Neal, T. M. Harris, F. E. Pritchard, and R. J. Woodcock, “Background Information and User Guide for Mil-F-8785B (ASG), ‘Military Specification-Flying Qualities of Piloted Airplanes’,” Tech. Rep. AD860865, Air Force Flight Dynamics Laboratory, Wright Patterson AFB, OH, June 1971.
- [7] anon, “Advertisement and Specification for a Heavier Than-Air Flying Machine,” Army Signal Corps Specification No. 486, December 23 1907.
- [8] O. Chanute, *Progress in Flying Machines*. Originally Published in *American Engineer and Railroad Journal*, New York, 1894, Mineola, New York: Dover, 1997.
- [9] O. Wright, *How We Invented the Airplane*. First Published in *Harper’s Magazine*, June 1953, original manuscript 1920, Dover, 1988.
- [10] D. T. McRuer and D. Graham, “Flight Control Century: Triumphs of the Systems Approach,”

- Journal of Guidance, Control and Dynamics*, Vol. 27, March-April 2004, pp. 161–173.
- [11] D. G. Mitchell, D. B. Doman, D. L. Key, D. H. Klyde, D. B. Leggett, D. J. Moorhouse, D. H. Mason, D. L. Raney, and D. K. Schmidt, “Evolution, Revolution, and Challenges of Handling Qualities,” *Journal of Guidance, Navigation, Control, and Dynamics*, Vol. 27, January-February 2004, pp. 12–28.
- [12] H. A. Soule, “Preliminary Investigation of the Flying Qualities of Airplanes,” NACA Report 700, 1943.
- [13] R. R. Gilruth, “Requirements for Satisfactory Flying Qualities of Airplanes,” NACA Report 755, 1943.
- [14] anon, “Stability and Control Requirements for Airplanes,” U. S. Navy Bureau of Aeronautics, Washington D. C., BuAer Specification No. 119B, August 1943.
- [15] anon, “Stability and Control Requirements for Airplanes,” U. S. Army-Air Forces Wright Patterson AFB, OH Specification No. C-1815, August 1943.
- [16] anon, “Military Specification, Flying Qualities of Piloted Airplanes,” MIL-F-8785(ASG), September 1954.
- [17] C. B. Westbrook, “The status and future of flying qualities requirements,” *2nd Annual Meeting of the American Institute of Aeronautics and Astronautics*, No. Paper 65-313, San Francisco, CA, July 26-29 1965.
- [18] C. R. Chalk and R. K. Wilson, “Airplane Flying Qualities Specification Revision,” *Journal of Aircraft*, Vol. 6, May - June 1969, pp. 232–239.
- [19] J. Hodgkinson, *Aircraft Handling Qualities*. AIAA, 1999.
- [20] anon, *Flying Qualities Textbook*, Vol. 2. Edwards Air Force Base, CA: USAF TPS, 1986.
- [21] W. G. Vincenti, *What Engineers Know and How They Know It, Analytical Studies from Aeronautical History*. Baltimore, MD: Johns Hopkins University Press, 1st ed., 1990.
- [22] anon, *MIL-STD-1797*. Department of Defense, March 1987.
- [23] G. Cooper and R. Harper, “The Use of Pilot Rating in the Evaluation of Aircraft Handling Qualities,” Tech. Rep. TN D-5153, NASA, April 1969.

-
- [24] R. Harper and G. Cooper, "Handling Qualities and Pilot Evaluation," *Journal of Guidance, Control and Dynamics*, Vol. 9, September-October 1986, pp. 515–529.
- [25] D. G. Mitchell and R. H. Hoh, "Low-Order Approaches to High-Order Systems: Problems and Promises," *Journal of Guidance, Control and Dynamics*, Vol. 5, September-October 1982, pp. 482–489.
- [26] T. P. Neal and R. E. Smith, "A Flying Qualities Criterion for Design of Fighter Flight-Control Systems," *AIAA Journal of Aircraft*, Vol. 8, October 1971, pp. 803–809.
- [27] R. Smith and N. Geddes, "Handling Quality Requirements for Advanced Aircraft Design: Longitudinal Mode," Technical Report AFFDL-TR-78-154, AFRL, Flight Dynamics Laboratory, August 1979.
- [28] R. E. Smith, "Effects of Control System Dynamics on Fighter Approach and Landing Longitudinal Flying Qualities," Tech. Rep. AFFDLTR78-122, AFRL, March 1978.
- [29] J. Hodgkinson, J. R. Wood, and R. H. Hoh, "An Alternate Method of Specifying Bandwidth for Flying Qualities," *AIAA Guidance and Control Conference*, No. AIAA-82-1609, San Diego, CA, AIAA, August 1982, pp. 571–578.
- [30] J. Gibson, "The Development of Alternate Criteria for FBW Handling Qualities," tech. rep., AGARD-508, October 1990.
- [31] anon, "Department of Defense, Joint Service Specification Guide, Air Vehicle," Rept. JSSG-2001A, October 2002.
- [32] L. R. N. Newcome, *Unmanned Aviation, A Brief History of Unmanned Aerial Vehicles*. AIAA, 1st ed., 2004.
- [33] anon, "Unmanned Aerial Vehicles Roadmap, 2002-2027," Office of the Secretary of Defense, December 2002.
- [34] T. H. Cox, C. J. Nagy, M. A. Skoog, I. A. Somers, and R. Warner, "A Report of the Civil UAV Capability Assessment," NASA Aeronautics Research Mission Directorate, December 2004.
- [35] anon, "RPV Flying Qualities Design Criteria," Technical Report AFFDL-TR-76-T25, Rock-

- well International Corporation, Columbus, OH, December 1976.
- [36] K. Breneman and M. Lower, "Flying Qualities of Remotely Piloted Vehicle," No. AIAA-1992-4083, Patuxent River, MD, U. S. Navy, Naval Air Warfare Center, 1992.
- [37] W. Williams, "A Simulator Based Approach to DT&E of Small UAVs," Master's thesis, University of South Australia, Mawson Lakes, South Australia 5095, December 2002.
- [38] W. Williams and M. Harris, "The Challenges of Flight-Testing Unmanned Air Vehicles," *Systems Engineering Test and Evaluation Conference*, Sydney, Australia, October 2002.
- [39] G. R. Spedding and P. B. S. Lissaman, "Technical Aspects of Microscale Flight Systems," *Journal of Avian Biology*, Vol. 29, December 1998, pp. 458–468.
- [40] W. Williams, "UAV Handling Qualities..... You Must be Joking," Aerospace Sciences Corporation Pty. Ltd., 2003.
- [41] T. M. Foster and W. J. Bowman, "Dynamic Stability and Handling-Qualities of Small Unmanned-Aerial-Vehicles," *43rd AIAA Aerospace Sciences Meeting and Exhibit*, No. AIAA-2005-1023, 2005.
- [42] J. Hodgkinson, "History of Low-Order Equivalent Systems for Aircraft Flying Qualities," *Journal of Guidance, Navigation, Control, and Dynamics*, Vol. 28, July 2005, pp. 557–583.
- [43] National Research Council, *Review of NASA's Aerospace Technology Enterprise, An Assessment of NASA's Aeronautics Technology Programs*. Washington, D. C.: National Academies Press, 2004.
- [44] S. Pace, *X-Planes, Pushing the Envelope of Flight*. Zenith Press, 1st ed., October 2003.
- [45] A. H. Bowers, J. W. Pahle, R. J. Wilson, B. C. Flick, and R. L. Rood, "An Overview of the NASA F-18 High Alpha Research Vehicle," Technical Memorandum 4772, NASA DFRC, Edwards, CA, October 1996.
- [46] M. E. Peters and D. A. II, "The determination of longitudinal flying qualities requirements for light weight unmanned aircraft," *AIAA Guidance, Navigation and Control Conference*, No. AIAA-1997-3701, New Orleans, LA, August 11-13 1997.
- [47] B. Mettler and M. B. T. a. Takeo Kanade, "System Identification of Small-Size Unmanned

- Helicopter Dynamics,” *American Helicopter Society 55th Forum*, Montreal, Quebec, Canada, American Helicopter Society, May 25-27 1999.
- [48] S. M. Burk, Jr. and C. F. Wilson, Jr., “Radio-Controlled Model Design and Testing Techniques for Stall/Spin Evaluation of General-Aviation Aircraft,” *SAE National Business Aircraft Meeting*, Wichita, KS, NASA-TM-80510, April 8-11 1975.
- [49] C. H. Wolowicz, J. S. Bowman, Jr., and W. P. Gilbert, “Similitude Requirements and Scaling Relationships as Applied to Model Testing,” Technical Paper TP-1435, NASA LaRC, Hampton, VA, August 1979.
- [50] D. T. McRuer and D. Graham, “Eight Years of Flight Control: Triumphs and Pitfalls of the Systems Approach,” *Journal of Guidance and Control*, Vol. 4, July - August 1981, pp. 353–362.
- [51] W. L. Brogan, *Modern Control Theory*. Upper Saddle River, NJ: Prentice-Hall, second ed., 1982.
- [52] D. Gangsaas, K. R. Bruce, J. D. Blight, and U.-L. Ly, “Application of Modern Synthesis to Aircraft Control: Three Case Studies,” *IEEE Transactions on Automatic Control*, Vol. AC-31, November 1986, pp. 995–1014.
- [53] M. C. Cotting and J. J. Burken, “Reconfigurable Control Design for the Full X-33 Flight Envelopw,” Technical Memorandum 2001-210396, NASA DFRC, Edwards, CA, August 2001.
- [54] J.-J. E. Slotine and W. Li, *Applied Nonlinear Control*. Upper Saddle River, NJ: Prentice-Hall, 1st ed., 1991.
- [55] J. T. Bosworth and P. S. Williams-Hayes, “Flight Test Results from the NF-15B Intelligent Flight Control System (IFCS) Project with Adaption to a Simulated Stabilator Failure,” Technical Memorandum 2007-214629, NASA DFRC, Edwards, CA, December 2007.
- [56] J. T. Bosworth, “Flight Results of the NF-15B Intelligent Flight Control System (IFCS) Aircraft with Adaption to a Longitudinally Destabilized Plant,” *AIAA Guidance, Navigation and Control Conference and Exhibit*, No. AIAA-2008-6985, Honolulu, Hawaii, August 18-21 2008.

-
- [57] F. Soares, J. J. Burken, and T. Marwala, *Neural Information Processing*, Vol. 4234/2006 of *Lecture Notes in Computer Science*, ch. Neural Network Applications in Advanced Aircraft Flight Control System, a Hybrid System, a Flight Test Demonstration, pp. 684–691. Springer, October 2006.
- [58] J. E. Tomayko, *The Story of Self-Repairing Flight Control Systems*. No. 1 in Dryden Historical Study, Edwards, CA: NASA Dryden Flight Research Center, 2003.
- [59] G. G. Balas and J. Hodgkinson, “Control Design Methods for Good Flying Qualities,” *AIAA Atmospheric Flight Mechanics Conference and Exhibit*, No. AIAA 2009-6319, Chicago, IL, AIAA, August 10-13 2009.
- [60] K. A. Wise, E. Lavretsky, and N. Hovakimyan, “Adaptive Control in Flight: Theory, Application, and Open Problems,” *In Proceedings of American Control Conference*, 2006, pp. 5996–5971.
- [61] C. Cao and N. Hovakimyan, “Design and Analysis of a Novel \mathcal{L}_1 Adaptive Controller, Part I: Control Signal and Asynptotic Stability,” *Proceedings of the 2006 American Control Conference*, June 14-16 2006.
- [62] C. Cao and N. Hovakimyan, “Design and Analysis of a Novel \mathcal{L}_1 Adaptive Controller, Part II: Guaranteed Transient Performance,” *Proceedings of the 2006 American Control Conference*, June 14-16 2006.
- [63] C. Cao and N. Hovakimyan, “A Novel \mathcal{L}_1 Neural Network Adaptive Control Architecture with Guaranteed Transient Performance,” *IEEE Transactions on Neural Networks*, Vol. 18(4), July 2007, pp. 1160–1171.
- [64] C. Cao and N. Hovakimyan, “Guaranteed Transient Performance with \mathcal{L}_1 Adaptive Controller for Systems with Unknown Time-Varying Parameters: Part I,” *Proc. of American Control Conference*, New York, NY, July 2007, pp. 3925–3930.
- [65] C. Cao and N. Hovakimyan, “Stability Margins of \mathcal{L}_1 Adaptive Controller, Part II,” *American Controls Conference*, 2007.
- [66] C. Cao, V. Patel, K. Reddy, N. Hovakimyan, and E. Lavretsky, “Are the Phase and Time-delay

- Margins Always Adversely Affected by High-gain?,” *Proc. of AIAA Guidance, Navigation and Control Conf.*, 2006. AIAA-2006-6347.
- [67] C. Cao and N. Hovakimyan, “ \mathcal{L}_1 Adaptive Output Feedback Controller for Systems with Time-varying Unknown Parameters and Bounded Disturbances,” *American Control Conference*, 2007, pp. 486–491.
- [68] C. Cao and N. Hovakimyan, “ \mathcal{L}_1 Adaptive Output Feedback Controller for Systems of Unknown Dimension,” *American Control Conference*, 2007, pp. 1191–1196.
- [69] C. Cao, N. Hovakimyan, I. Kaminer, V. Patel, and V. Dobrokhodov, “Stabilization of Cascaded Systems via \mathcal{L}_1 Adaptive Controller with Application to a UAV Path Following Problem and Flight Test Results,” *American Control Conference*, 2007, pp. 1787–1792.
- [70] C. Cao, N. Hovakimyan, and E. Lavretsky, “Application of \mathcal{L}_1 Adaptive Controller to Wing Rock,” *In Proc. of AIAA Guidance, Navigation and Control Conference*, 2006. AIAA 2006-6426.
- [71] J. Wang, C. Cao, V. Patel, N. Hovakimyan, and E. Lavretsky, “ \mathcal{L}_1 adaptive neural network controller for autonomous aerial refueling with guaranteed transient performance,” *In Proc. of AIAA Guidance, Navigation and Control Conference*, 2006. AIAA 2006-6206.
- [72] J. Wang, V. Patel, C. Cao, N. Hovakimyan, and E. Lavretsky, “ \mathcal{L}_1 adaptive neural network controller for autonomous aerial refueling in the presence of unknown actuator failures,” *In Proc. of AIAA Guidance, Navigation and Control Conference*, 2007. AIAA 2007-6313.
- [73] R. Beard, N. Knoebel, C. Cao, N. Hovakimyan, and J. Matthews, “An \mathcal{L}_1 Adaptive Pitch Controller for Miniature Air Vehicles,” *Proc. of AIAA Guidance, Navigation & Control Conf.*, Keystone, CO, 2006. AIAA-2006-6777.
- [74] Y. Lei, C. Cao, E. Cliff, N. Hovakimyan, A. Kurdila, M. Bolender, and D. Doman, “Design of an \mathcal{L}_1 Adaptive Controller for an Air-Breathing Hypersonic Vehicle Model with Unmodelled Dynamics,” *Proc. of AIAA Guidance, Navigation & Control Conf.*, Hilton Head Island, SC, 2007. AIAA 2007-6527.
- [75] I. Gregory, V. Patel, C. Cao, and N. Hovakimyan, “ \mathcal{L}_1 Adaptive Control Laws for Flexible

- Wind Tunnel Model of High-Aspect Ratio Flying Wing,” *Proc. of AIAA Guidance, Navigation & Control Conf.*, Hilton Head Island, SC, 2007. AIAA 2007-6525.
- [76] V. V. Patel, C. Cao, N. Hovakimyan, K. Wise, and E. Lavretsky, “ \mathcal{L}_1 Adaptive Controller for Tailless Unstable Aircraft,” *In Proc. of American Control conference*, 2007, pp. 5272–5277.
- [77] V. Patel, C. Cao, N. Hovakimyan, K. Wise, and E. Lavretsky, “ \mathcal{L}_1 Adaptive Controller for Tailless Unstable Aircraft in the Presence of Unknown Actuator Failures,” *Proc. of AIAA Guidance, Navigation and Control Conf.*, Hilton Head Island, SC, 2007. AIAA 2007-6314.
- [78] National Academy of Engineering, *Educating the Engineer of 2020*. National Academies Press, 1st ed., 2005.
- [79] National Research Council, *How People Learn*. Washington, D. C.: National Academy Press, expanded ed., 2000.
- [80] M. Weimer, *Learner-Centered Teaching*. San Francisco, CA: Jossey Bass, A Wiley Company, 1st ed., 2002.
- [81] K. A. Smith, S. D. Sheppard, D. W. Johnston, and R. T. Johnson, “Pedagogies of Engagement: Classroom-Based Practices,” *Journal of Engineering Education*, Vol. 94, January 2005, pp. 87–101.
- [82] H. S. Barrows, “Problem-Based Learning in Medicine and Beyond: A Brief Overview,” *New Directions for Teaching and Learning*, Vol. 1996, No. 68, 1996, pp. 3–12.
- [83] M. P. Fried, R. Satava, S. Weghorst, A. G. Gallagher, C. Sasaki, D. Ross, M. Sinanan, J. I. Uribe, M. Zeltsan, H. Arora, and H. Cuellar, “Identifying and Reducing Errors with Surgical Simulation,” *Quality and Safety in Healthcare*, Vol. 13, No. Supplement 1, 2004, pp. 19–26.
- [84] A. Liu, F. Tendick, K. Cleary, and C. Kaufmann, “A Survey of Surgical Simulation: Applications, Technology, and Education,” *Prescence*, Vol. 12, December 2003, pp. 599–614.
- [85] M. Wesch, “Anti-Teaching: Confronting the Crisis of Significance,” *Education Canada*, Vol. 48, Spring 2008, pp. 4–7.
- [86] L. Meirovitch, *Methods of Analytical Dynamics*. Mineola, New York: Dover, 1998.
- [87] C. D. Perkins and R. E. Hage, *Airplane Performance Stability and Control*. Princeton, New

- Jersey: John Wiley and Sons, 1949.
- [88] D. McRuer, I. Ashkenas, and D. Graham, *Aircraft Dynamics and Automatic Control*. Princeton, New Jersey: Princeton University Press, 1973.
- [89] B. Stevens and F. Lewis, *Aircraft Control and Simulation*. New York, NY: John Wiley and Sons, 1st ed., 1992.
- [90] R. E. McFarland, "A Standard Kinematic Model for Flight Simulations at NASA-Ames," Contractor Report CR-2497, NASA ARC, Moffett Field, Ca, January 1975.
- [91] K. Ogata, *Modern Control Engineering*. Upper Saddle River, NJ: Prentice-Hall, third ed., 1997.
- [92] D. Kincaid and W. Cheney, *Numerical Analysis*. Pacific Grove, CA: Brooks/Cole Publishing, 1st ed., 1991.
- [93] R. H. Hoh, D. G. Mitchell, and J. Hodgkinson, "Bandwidth - A Criterion for Highly Augmented Airplanes," *AGARD Conference Proceedings No.333, Criteria for Handling Qualities of Military Aircraft*, Ft. Worth, Texas, NATO, April 1982.
- [94] anon, "Unmanned Aerial Vehicles Roadmap, 2005-2030," Office of the Secretary of Defense, August 4 2005.
- [95] anon, "Unmanned Systems Roadmap, 2007-2032," Office of the Secretary of Defense, December 10 2007.
- [96] anon, "Unmanned Systems Integrated Roadmap, 2009-2034," Office of the Secretary of Defense, 2009.
- [97] J. D. Anderson, Jr., *Introduction to Flight*. New York, NY: McGraw Hill, 5th ed., 2005.
- [98] K. Munson and M. Streetly, *Jane's Unmanned Aerial Vehicles and Targets*. Jane's Information Group, 24 th ed., May 2005.
- [99] J. Pike, <http://www.globalsecurity.org/>. May 2008.
- [100] A. L. Velocci,Jr, *Aerospace Sourcebook*. New York, NY: Aviation Week and Space Technology, McGraw Hill, January 2008.
- [101] A. L. Velocci,Jr, *Aerospace Sourcebook*. New York, NY: Aviation Week and Space Technol-

- ogy, McGraw Hill, January 2007.
- [102] T. R. Yechout, S. L. Morris, D. E. Bossert, and W. F. Hallgren, *Introduction to Aircraft Flight Mechanics: Performance, Static Stability, Dynamic Stability, and Classic Feedback Control*. Reston, Va.: AIAA Education Series, 1st ed., 2003.
- [103] U. S. Department of Labor, “CPI Inflation Calculator,” http://www.bls.gov/data/inflation_calculator.htm, November 2010.
- [104] anon, *MIL-HDBK-1797*. Department of Defense, December 19 1997.
- [105] anon, “Aerospace - Flight Control Systems - General Specification for Design, Installation and Test of Piloted Military Aircraft,” Aerospace Standard AS94900, SAE Aerospace, July 2007.
- [106] anon, “Aeronautical Design Standard Performance Specification Handling Qualities Requirements for Military Rotorcraft,” Design Standard ADS-33E-PRF, US Army Aviation and Missile Command, Aviation Engineering Directorate, Redstone Arsenal, Alabama, March 2000.
- [107] D. J. Moorhouse and R. J. Woodcock, “Background Information and User Guide for Mil-F-8785C), ‘Military Specification-Flying Qualities of Piloted Airplanes’,” Tech. Rep. AFWAL-TR-81-3109, Air Force Flight Dynamics Laboratory, Wright Patterson AFB, OH, July 1982.
- [108] W. Bihrlé, “A Handling Qualities Theory for Precise Flight Path Control,” Tech. Rep. AFFDL-TR-65-195, AFRL, Wright Patterson AFB, OH, June 1965.
- [109] W. F. Philips and R. J. Niewoehner, “Characteristic Length and Dynamic Time Scale Associated with Aircraft Pitching Motion,” *Journal of Aircraft*, Vol. 46, March-April 2009, pp. 572–582.
- [110] J. J. Harris and G. T. Black, “YF-22 Control Law Development and Flying Qualities,” *Atmospheric Flight Mechanics Conference*, No. AIAA-96-3379, San Diego, CA, AIAA, July 29-31 1996.
- [111] D. A. DiFranco, “Higher-Order Control System Dynamics and Longitudinal Handling Qualities,” *Journal of Aircraft*, Vol. 7, September - October 1970, pp. 457–464.
- [112] T. P. Neal and R. E. Smith, “An In-Flight Investigation to Develop Control System Design

- Criteria for Fighter Airplanes,” Tech. Rep. AFFDLTR70-074, AFRL, December 1970.
- [113] J. Hodgkinson, “The Application of Equivalent Systems to MIL-F-8785B,” *Contrails*, December 1978, pp. 203–218.
- [114] J. Hodgkinson, “Equivalent Systems Criteria for Handling Qualities of Military Aircraft,” *AGARD Conference Proceedings No.333, Criteria for Handling Qualities of Military Aircraft*, Ft. Worth, Texas, NATO, April 1982.
- [115] J. R. Wood and J. Hodgkinson, “Definition of Acceptable Levels of Mismatch for Equivalent Systems of Augmented CTOL Aircraft,” Tech. Rep. MDC-A6792, McDonnell Aircraft Company, St. Louis, MO, September 17 1980.
- [116] P. Fitzgerald, “Modern Flight Control System Design for the Jindivik UAV,” Master’s thesis, Cranfield University, Cranfield, Bedfordshire, UK, September 2000.
- [117] D. G. Mitchell and D. H. Klyde, “A Critical Examination of PIO Prediction Criteria,” *AIAA Atmospheric Flight Mechanics Conference and Exhibit*, No. AIAA-98-4335, Boston, MA, AIAA, August 10-12 1998.
- [118] D. G. Mitchell and R. H. Hoh, “Development of a Unified Method to Predict PIO,” *AIAA Atmospheric Flight Mechanics Conference*, No. AIAA-96-3435, San Diego, CA, AIAA, July 29-31 1996.
- [119] J. C. Gibson, “Piloted Handling Qualities Design Criteria for High Order Flight Control Systems,” *AGARD Conference Proceedings No.333, Criteria for Handling Qualities of Military Aircraft*, Ft. Worth, Texas, NATO, April 1982.
- [120] R. H. Hoh and D. G. Mitchell, “The Role of Handling Qualities Specifications in Flight Control System Design,” *Active Control Technology: Applications and Lessons Learned* (L. M. B. d. Costa Campos and H. Wunnenberg, eds.), Vol. 1, Turin, Italy, NATO, Advisory Group for Aerospace Research and Development (AGARD), May 9-13 1994, pp. 1–1 – 1–12.
- [121] S. Jacobson and J. Moynes, “Ride Qualities Criteria for the B-2 Bomber,” *AIAA / AHS / ASEE Aircraft Design, Systems, and Operations Meeting*, No. AIAA-90-3256, Dayton, OH, September 17-19 1990.

-
- [122] NASA LaRC, *Proceedings of Conference on Ride Qualities of air, surface, and water vehicles with emphasis on human factors engineering for comfort in transportation*, No. NASA-TM-X-2620, Hampton, VA, October 1 1972.
- [123] J. W. Rustenburg, "Ride Quality Design Criteria for Aircraft with Active Mode Control Systems," Technical Report ASD-TR-72-64, Aeronautical Systems Division, Wright-Patterson Air Force Base, Wright Patterson AFB, OH, October 1972.
- [124] D. G. Mitchell, R. H. Hoh, B. L. Aponso, and D. H. Klyde, "Proposed Incorporation of Mission-Oriented Flying Qualities into MIL-STD-1797A," Technical Report WL-TR-94-3162, Wright Laboratory, Wright Patterson AFB, OH, October 1994.
- [125] D. J. Wilson, D. R. Riley, and K. D. Citurs, "Aircraft Maneuvers for the Evaluation of Flying Qualities and Agility," Tech. Rep. WL-TR-93-3081, Wright Laboratory, Wright Patterson AFB, OH, 1993.
- [126] anon, "Flying Qualities of Piloted Aircraft," Department of Defense Interface Standard MIL-STD-1797B, Department of Defense, Wright Patterson AFB, OH, February 15 2006.
- [127] J. Hodgkinson, J. R. Wood, and R. H. Hoh, "An Alternate Method of Specifying Bandwidth for Flying Qualities," *AIAA Guidance, Navigation and Control Conference*, No. AIAA-82-1609, San Diego, CA, AIAA, August 1982, pp. 571–578.
- [128] M. C. Cotting, A. Wolek, J. F. Murtha, and C. A. Woolsey, "Developmental Flight Testing of the SPAARO UAV," *48th Annual AIAA Aerospace Sciences Meeting and Exhibit*, No. AIAA-2010-295, Orlando, FL, January 4-7 2010.
- [129] J. F. Murtha, M. C. Cotting, A. Wolek, T. Aarons, and C. A. Woolsey, "The Educational Impact of Creating a New UAV for Curriculum Enhancement," *27th AIAA Atmospheric Flight Mechanics Conference and Exhibit*, No. AIAA-2009-5851, Chicago, IL, August 10-13 2009.
- [130] J. Roskam, *Airplane Design*, Vol. VI. Ottawa, Kansas: Roskam Aviation and Engineering Corporation, 1986.
- [131] H. L. Dryden, "A Review of the Statistical Theory of Turbulence," *Quarterly of Applied Mathematics*, Vol. 1, April 1943, pp. 7–42.

-
- [132] T. V. Karman, "Progress in the Statistical Theory of Turbulence," *Proceedings of the National Academy of Sciences*, Vol. 34, August 1948, pp. 530–539.
- [133] J. C. Houbolt, R. Stiener, and K. G. Pratt, "Dynamic Response of Airplanes to Atmospheric Turbulence Including Flight Data on Input and Response," Technical Report TR-R-19, NASA LaRC, Hampton, VA, June 1964.
- [134] M. C. Cotting, "An Initial Study to Categorize Unmanned Aerial Vehicles for Flying Qualities Evaluation," *47th Annual AIAA Aerospace Sciences Meeting and Exhibit*, No. AIAA-2009-307, Orlando, FL, January 5 - 8 2009.
- [135] L. T. Nguyen, M. E. Ogburn, W. P. Gilbert, K. S. Kibler, P. W. Brown, and P. L. Deal, "Simulator Study of Stall/Post Stall Characteristics of a Fighter Airplane with Relaxed Longitudinal Static Stability," Technical Paper 1538, NASA LaRC, Hampton, VA, December 1979.
- [136] G. P. Walker and D. A. Allen, "X-35B STOVL Flight Control Law Design and Flying Qualities," *Biennial International Powered Lift Conference and Exhibit*, No. AIAA-2002-6018, Williamsburg, VA, AIAA, November 5-7 2002.
- [137] R. Wacker, D. F. Enns, D. J. Bugajski, S. Munday, and S. Merkle, "X-38 Application of Dynamic Inversion Flight Control," *Advances in the Astronautical Sciences*, Vol. 107, No. AAS 01-016, 2001, pp. 233–250.
- [138] Anon, "Application of Multivariable Control Theory to Aircraft Control Laws," Technical Report WL-TR-3099, Wright Laboratory, Dayton, OH, May 1996.
- [139] K. Wise and E. L. e. al, "Adaptive Flight Control of a Sensor Guided Munition.," *Proc. of AIAA GNC Conf.*, 2005.
- [140] C. Cao and N. Hovakimyan, "Stability Margins of \mathcal{L}_1 Adaptive Controller: Part II," *Proc. of American Control Conference*, New York, NY, July 2007, pp. 3931–3936.
- [141] C. Cao and N. Hovakimyan, "Design and Analysis of a Novel \mathcal{L}_1 Adaptive Control Architecture, Part I: Control Signal and Asymptotic Stability," *Proc. of American Control Conference*, Minneapolis, MN, June 2006, pp. 3397–3402.
- [142] C. Cao and N. Hovakimyan, "Design and Analysis of a Novel \mathcal{L}_1 Adaptive Control Archi-

- ecture, Part II: Guaranteed Transient Performance,” *Proc. of American Control Conference*, Minneapolis, MN, June 2006, pp. 3403–3408.
- [143] C. Cao and N. Hovakimyan, “ \mathcal{L}_1 Adaptive Controller for Systems with Unknown Nonlinearities: Part I,” *Submitted to IEEE Conference on Decision and Control*, 2007.
- [144] C. Cao and N. Hovakimyan, “ \mathcal{L}_1 Adaptive Controller for Nonlinear Systems in the Presence of Unmodelled Dynamics: Part II,” *Submitted to IEEE Conference on Decision and Control*, 2007.
- [145] C. Cao and N. Hovakimyan, “ \mathcal{L}_1 Adaptive Controller for Systems in the Presence of Unmodeled Actuator Dynamics,” *Submitted to IEEE Conference on Decision and Control*, 2007.
- [146] C. Cao and N. Hovakimyan, “ \mathcal{L}_1 Adaptive Controller for Multi-Input Multi-Output Systems in the Presence of Unmatched Disturbances,” *Submitted to IEEE Conference on Decision and Control*, 2007.
- [147] I. Kammer, O. Yakimenko, V. Dobrokhodov, A. Pascoal, N. Hovakimyan, V. V. Patel, C. Cao, and A. Young, “Coordinated path following for time-critical missions of multiple UAVs via \mathcal{L}_1 adaptive output feedback controllers,” *AIAA Guidance, Navigation and Control Conference*, 2007.
- [148] B. L. Stevens and F. L. Lewis, *Aircraft Control and Simulation*. Wiley, 2 ed., 2004.
- [149] K. C. Scalera and W. C. Durham, “Modification of a Surplus Navy 2F122A A-6E OFT for Flight Dynamics Research and Instruction,” *AIAA Modeling and Simulation Technologies Conference and Exhibit*, No. AIAA-1998-4180, Boston, MA, AIAA, August 10-12 1998.
- [150] J.-B. Pomet and L. Praly, “Adaptive Nonlinear Regulation: Estimation from the Lyapunov Equation,” *IEEE Transactions on Automatic Control*, Vol. 37, June 1992, pp. 729 – 740.
- [151] M. C. Cotting and T. H. Cox, “A Generic Guidance and Control Structure for Six-Degree-of-Freedom Conceptual Aircraft Design,” *AIAA Aerospace Sciences Meeting and Exhibit*, No. AIAA20050032, Reno, NV, January 2005.
- [152] H. K. Khalil, *Nonlinear Systems*. Upper Saddle River, NJ: Prentice-Hall, third ed., 2002.
- [153] A. Isidori, “The matching of a prescribed linear input-output behavior in a nonlinear system,”

-
- Automatic Control, IEEE Transactions on*, Vol. 30, Mar 1985, pp. 258–265.
- [154] D. F. Enns, D. J. Bugajski, R. Hendrick, and G. Stein, “Dynamic Inversion: An Evolving Methodology for Flight Control Design,” *International Journal of Control*, Vol. 59, January 1994, pp. 71–79.
- [155] M. Rais-Rohani, K. Koenig, and T. Hannigan, “Keeping students engaged: an overview of three introductory courses in aerospace engineering,” *2003 ASEE Annual Conference and Exposition*, Nashville, Tennessee, 2003.
- [156] H. C. Smith, “Teaching flight test engineering with a PC-based simulator,” *2001 ASEE Annual Conference and Exposition*, Albuquerque, New Mexico, 2001.
- [157] T. Liu and M. Schulte, “Flight Testing Education at Western Michigan University,” *45th AIAA Aerospace Sciences Meeting and Exhibit*, Reno, Nevada, 2007.
- [158] M. C. Cotting, L. S. McCue, and W. C. Durham, “The instructional design and redesign of an undergraduate-level, simulator-based course on “Flight Test Techniques”,” *ASEE Conference and Exposition*, No. AC2007-93, Honolulu, Hawaii, June 2007.
- [159] M. C. Cotting, L. S. McCue, and W. C. Durham, “Simulator-based flight test engineering as a capstone to the dynamics and control curriculum,” *45th AIAA Aerospace Sciences Meeting and Exhibit*, No. AIAA-2007-0699, Reno, NV, January 2007.
- [160] R. M. Felder and R. Brent, “Understanding Student Differences,” *Journal of Engineering Education*, Vol. 94, January 2005, pp. 57–72.
- [161] W. B. Spaulding, “The Undergraduate Medical Curriculum (1969 Model) McMaster University,” *Canadian Medical Association Journal*, Vol. 100, April 1969, pp. 659–664.
- [162] S. Muller, *Physicians for the Twenty-First Century: Report of the Project Panel on the General Professional Education of the Physician and College Preparation for Medicine*. No. 59, *Journal of Medical Education*, 1984.
- [163] A. B. Rosenstein, “A Study of Profession and Professional Education,” Tech. Rep. EDP 7-68, School of Engineering and Applied Science, University of California, Los Angeles, 1968.
- [164] C. L. Dym, A. M. Agogino, O. Eris, D. D. Frey, and L. J. Leifer, “Engineering Design Think-

- ing, Teaching, and Learning,” *Journal of Engineering Education*, Vol. 94, January 1995, pp. 103–120.
- [165] K. C. Cohen, *Internet links for science education: student-scientist partnerships*. Plenum Press, 1997.
- [166] K. A. Bruffee, *Collaborative Learning, Higher Education, Interdependence, and the Authority of Knowledge*. Johns Hopkins University Press, 1998.
- [167] J. R. Katzenbach and D. K. Smith, *The Wisdom of Teams: Creating the High-Performance Organization*. Harvard Business School Press, 1st ed., 1993.
- [168] K. Rohnke and S. Butler, *Quicksilver*. Project Adventure, Inc., Dubuque, Iowa: Kendall/Hunt Publishing Co., 1st ed., 1995.
- [169] B. M. Slator and H. C. Chaput, “Learning by Learning Roles: A Virtual Role-Playing Environment for Tutoring,” *Intelligent Tutoring Systems*, 1996, pp. 668–676.
- [170] B. M. Slator, J. Clark, P. McClean, B. Saini-Eidukat, and A. R. White, “Research on role-based learning technologies,” *Proceedings. IEEE International Conference on Advanced Learning Technologies*, IEEE, Madison, WI 2001, pp. 37–40.
- [171] R. E. Mayer, *Multimedia Learning*. Cambridge University Press, first ed., 2001.
- [172] R. Beck and W. C. Durham, “Flight simulation in flight dynamics education,” *AIAA Atmospheric Flight Mechanics Conference and Exhibit*, No. AIAA-1999-4361, Portland, OR, AIAA, August 9-11 1999.
- [173] G. L. Gallagher, L. B. Higgins, L. A. Khinoo, and P. W. Pierce, “U.S. Naval Test Pilot School Flight Test Manual, Fixed Wing Performance,” Tech. Rep. USNTPS-FTM-NO. 108 (Preliminary), Veda Incorporated Contract N00421-90-C-0022, 30 September 1992.
- [174] Aircraft Division, “U.S. Naval Test Pilot School Flight Test Manual, Fixed Wing Stability and Control: Theory and Flight Test Techniques,” Tech. Rep. USNTPS-FTM-No. 103, Naval Air Warfare Center, Patuxent River, Maryland, January 1997.
- [175] B. Bloom and D. Krathwohl, *Taxonomy of educational objectives, Handbook 1: Cognitive domain*. New York: Addison-Wesley, 1984.

- [176] P. C. Wankat and F. S. Oreovicz, *Teaching Engineering*. 1992. Reprinted at https://engineering.purdue.edu/ChE/News_and_Events/Publications/teaching_engineering/index.html.
- [177] R. Felder and R. Brent, “Objectively speaking,” *Chemical Engineering Education*, Vol. 31, No. 3, 1997, pp. 178–179.
- [178] J. E. Stice, “A First Step Toward Improved Teaching,” *Engineering Education*, Vol. 66, February 1976, pp. 394–398.
- [179] N. Gronlund, *How to write and use instructional objectives*. Upper Saddle River, NJ: Prentice-Hall, 6 ed., 2000.
- [180] M. J. Prince and R. M. Felder, “Inductive Teaching and Learning Methods: Definitions, Comparisons, and Research Bases,” *Journal of Engineering Education*, Vol. 95, April 2006, pp. 123–138.
- [181] N. D. Fleming and C. Mills, “Not another inventory, rather a catalyst for reflection,” *To Improve the Academy*, Vol. 11, 1992.
- [182] S. Montgomery, “Chemical Engineering 580/Engineering 580: Teaching Engineering,” Lecture Notes, Winter 2004.
- [183] anon, *U.S. Military Specification MIL-F-8785C*. Department of Defense, 5 November 1980.
- [184] M. C. Cotting, J. F. Murtha, L. Techy, and C. A. Woolsey, “Examples of Augmentation of an Atmospheric Flight Mechanics Curriculum using UAVs,” *27th AIAA Atmospheric Flight Mechanics Conference and Exhibit*, No. AIAA 2009-5852, Orlando, FL, August 10-13 2009.

Self Assessment Surveys for AOE4984 Flight Test Techniques

A.1 Student survey

The surveys were anonymous and contained both short answer and questions with a rating scale from 1 to 5 to rate pre-written statements. A total of 39 students completed the surveys over the course of two course offerings. Selected results from these surveys are listed below:

1. This class required _____ time than my other classes.

Considerably More ¹ ² ³ ⁴ ⁵ Considerably Less

Average Response: 2.6

2. I learned _____ than I expected from this class.

Considerably More ¹ ² ³ ⁴ ⁵ Considerably Less

Average Response: 1.77

3. The pacing of the course was:

Too Fast 1 2 3 4 5 Too Slow

Average Response: 2.94

4. Basing my grade solely on the flight test reports reflects my understanding of the material presented in this class.

Strongly Agree 1 2 3 4 5 Strongly Disagree

Average Response: 2.48

5. I would recommend this class to my peers.

Strongly Agree 1 2 3 4 5 Strongly Disagree

Average Response: 1.155

6. This class has improved my overall understanding of aerospace engineering.

Strongly Agree 1 2 3 4 5 Strongly Disagree

Average Response: 1.415

7. I better understand the theories and concepts taught in my other classes based on the topics taught in this course.

Strongly Agree 1 2 3 4 5 Strongly Disagree

Average Response: 1.735

8. I discussed this class with people outside of my test group.

Often 1 2 3 4 5 Never

Average Response: 2.26

9. I worked _____ than my other classes on this course.

Harder ¹ ² ³ ⁴ ⁵ Less

Average Response: 2.44

10. I have a _____ understanding of the basic concepts involved in flight testing aircraft after taking this course.

Excellent ¹ ² ³ ⁴ ⁵ Poor

Average Response: 1.79

11. My Overall Rating of this course is:

Excellent ¹ ² ³ ⁴ ⁵ Poor

Average Response: 1.355

A sampling of written Comments from the student's survey are also included below:

1. "This class actually covered material and procedures required in the Real World, not just the theory behind it."
2. "Actually applying knowledge learned in other classes"
3. "I got into engineering to be hands on and this was one of the best ways to do it."
4. "It provided a new conduit through which to demonstrate the material taught through the AE curriculum"
5. "Helps you see how everything from previous courses comes together."
6. "It gives a feel for mathematical values."

7. "It reinforced topics learned in other courses and gave those concepts real-world meaning."
8. "I feel that this course should be required at the junior or senior level because it brings hands-on, real meaning to all of the theory and number crunching we do in other classes. This was one of the few classes where I actually got to "do engineering" ."
9. "I liked that the course required us to come up with our own flight test cards. It really made us think about what we were doing."
10. "This was one of the most interesting and practical courses I've taken. It showed us why we need to know what we are learning."
11. "My favorite course of my 5 years here. I learned more in this class than any other. The first time I was excited to be an engineer."

A.2 Post graduation

An attempt was made to contact students that have taken the flight test techniques course after at least one year past course completion. Seventeen students that were contacted completed another anonymous survey. Again the survey was a mixture of short answer and questions with a rating scale from 1 to 5 to rate pre-written statements.

1. I am currently working in the flight test field
6 True, 11 False
2. AOE4984 Flight Test Techniques was discussed in the interview for my current position
11 True, 6 False
3. My understanding of basic aerospace engineering principals was enhanced by taking AOE4984 Flight Test Techniques.

Strongly Agree ¹ ² ³ ⁴ ⁵ Strongly Disagree

Average Response: 1.35

For the next set of questions please use the following definitions in responding:

PROCEDURAL understanding: a person's ability to use algorithms, rules, or formal language to represent a system.

CONCEPTUAL understanding: a person's ability to represent major concepts within a system.

4. My PROCEDURAL understanding of aerospace engineering principals was enhanced by taking AOE4984 Flight Test Techniques.

Strongly Agree ¹ ² ³ ⁴ ⁵ Strongly Disagree

Average Response: 1.94

5. My CONCEPTUAL understanding of aerospace engineering principals was enhanced by taking AOE4984 Flight Test Techniques.

Strongly Agree ¹ ² ³ ⁴ ⁵ Strongly Disagree

Average Response: 1.47

6. My current position requires me to have a strong PROCEDURAL understanding of aerospace engineering principals.

Strongly Agree ¹ ² ³ ⁴ ⁵ Strongly Disagree

Average Response: 2.35

7. My current position requires me to have a strong CONCEPTUAL understanding of aerospace engineering principals.

Strongly Agree ¹ ² ³ ⁴ ⁵ Strongly Disagree

Average Response: 1.67

8. The use of a flight simulator enhanced my understanding of aerospace engineering concepts.

Strongly Agree ¹ ² ³ ⁴ ⁵ Strongly Disagree

Average Response: 1.35

9. The teaming arrangements of AOE4984 Flight Test Techniques prepared me for my current work environment.

Strongly Agree ¹ ² ³ ⁴ ⁵ Strongly Disagree

Average Response: 1.88

10. Exposure to a flight simulator earlier in the aerospace engineering curriculum would have increased my understanding of aerospace engineering concepts.

Strongly Agree ¹ ² ³ ⁴ ⁵ Strongly Disagree

Average Response: 2.00

11. This course played a _____ role in impressing a potential employer during the interview process.

Significant ¹ ² ³ ⁴ ⁵ Insignificant

Average Response: 2.88

A sampling of written Comments from the student's survey are also included below:

1. "Flight Test was one of the few labs that I understood not only what we were testing for

and what we were supposed to get, but much more importantly I understood why I got what I did and why it agreed or disagreed with the expected answer. Using a flight simulator allowed the strongest correlation between text book ideal cases and real world relevance and considerations. This should be a mandatory course for all AOE majors during their sophomore year. You can talk concepts and procedures all day, but without some first hand knowledge or experience it is very difficult to turn the text-book definitions in to real life effects and applications. Within the first week of any AOE course you can easily pick out the majority of people with and without flight experience.”

2. “The flight simulator provided a great hands-on experience to reinforce concepts learned in lecture. An hour flying the simulator experiencing the different modes of stability was comparable in value to weeks of lecture. Being able to calculate a max range climb/cruise/descent profile in an effort to make it to an airstrip, and then successfully fly the profile with a limited amount of fuel was much better than any scenario that could be presented in a Performance class.”
3. “Looking back on the class, everything in the real life flight test field is exactly like the class.”
4. “Using a simulator to learn about flight testing is ideal. It allowed us to go through everything we would have for a real flight test without the need to worry as much about safety and cost.”
5. “Extensive teamwork was required to complete the work required for the mission on the simulator, as well as complete the report. The same type of teamwork is required of me in my current job.”
6. “I came to work with a good understanding of the team mentality that is critical to perform my job effectively, and also gave me real life examples of problems that could occur.”
7. “I work with teams of various people almost everyday at my job. Without working together not much would get done. Time working on teams in college helps prepare for this.”

8. "I currently work in a team environment. Being able to communicate and work with others with a variety of personality traits is difficult. The team arrangement in this class prepared me for my current work environment."
9. "I think it was the most important class that I took at Virginia Tech. It exposed me to the type of job I wanted as well as enabling me to get a better grasp on the concepts that I had spent the last 3 years of study learning about."
10. "The flight test class made for an excellent capstone to my engineering degree and allowed me to put everything I had learned into practice and apply to practical applications. It was the first class that made me honestly feel like I was in the right major, which is a shame considering it was taken in my last semester. "
11. "The simulator was the best hands on flight experience that we received with our degree. Far too often we would learn a topic in the classroom with no way to apply it. I personally think it is essential for engineers to be in touch with what is actually going on with the operational side of the aircraft we are designing. "
12. "While I would have thought the International Design Team would have been the main topic of my interviews, the project was barely mentioned after they asked about Flight Test Techniques. My first three job offers were for flight testing positions, and I'm certain I wouldn't have been offered those opportunities without this course."
13. "Flight test techniques was without a doubt my favorite class I took in the aerospace curriculum. It helped reinforce the principles learned in other classes and gave me the connection to the real world that I needed. Too much of the aerospace curriculum is abstract, flight test was much more realistic. "
14. "The flight test class alone made a greater impact on my desire to be a test pilot more than all the other classes put together. "

15. "I think flight simulator assignments should be incorporated into intro to aerospace engineering and in aircraft flight dynamic courses... I can honestly say I didn't understand several aerospace principals until I was exposed to an actual aircraft. I feel that it is highly unlikely that the department can expose students to real aircraft, but I think a simulator could help fill the gap."
16. "I've been to a few performance flight tests and they are exactly how I remember them from the flight test course. It wasn't until I went to the flight tests that I truly appreciated how close the flight test class was to the real world. "
17. "I think the flight test techniques course would be advantageous to any aerospace engineer whether they are pursuing flight testing or not. For me it has solidified the foundation of my skills for what I want to continue doing and has reminded me why I wanted to become an engineer in the first place. "

A.3 Employer

An attempt was made to contact employers of former students that have taken the flight test techniques course after at least one year past course completion. Three employers completed the anonymous survey. Again the survey was a mixture of short answer and questions with a rating scale from 1 to 5 to rate pre-written statements.

1. AOE4984 Flight Test Techniques was discussed in the interview for the AOE4984 graduate
3 True, 0 False

2. I was impressed that the AOE4984 graduate was exposed to flight testing at an undergraduate level
Strongly Agree ¹ ² ³ ⁴ ⁵ Strongly Disagree

Average Response: 1.33

For the next set of questions please use the following definitions in responding:

PROCEDURAL understanding: a person's ability to use algorithms, rules, or formal language to represent a system.

CONCEPTUAL understanding: a person's ability to represent major concepts within a system.

3. The AOE4984 graduate has a higher PROCEDURAL understanding of aerospace engineering principals than a typical employee of his tenure.

Strongly Agree ¹ ² ³ ⁴ ⁵ Strongly Disagree

Average Response: 1.67

4. The AOE4984 graduate has a higher CONCEPTUAL understanding of aerospace engineering principals than a typical employee of his tenure.

Strongly Agree ¹ ² ³ ⁴ ⁵ Strongly Disagree

Average Response: 1.67

5. New hires working for me are required to have a stronger than average PROCEDURAL understanding of aerospace engineering principals.

Strongly Agree ¹ ² ³ ⁴ ⁵ Strongly Disagree

Average Response: 2.33

6. New hires working for me are required to have a stronger than average CONCEPTUAL understanding of aerospace engineering principals.

Strongly Agree ¹ ² ³ ⁴ ⁵ Strongly Disagree

Average Response: 1.67

7. I would prefer that all my new hire engineers have been exposed to flight testing at the undergraduate level.

Strongly Agree Strongly Disagree

Average Response: 1.67

8. Exposure to flight testing prior to arrival at my facility has _____ the effectiveness of AOE4984 graduate as compared to the average new hire in his position.

Strongly Increased Strongly Decreased

Average Response: 2.00

9. I would be interested in having all my new hires participate in a flight testing experience similar to AOE4984 .

Strongly Agree Strongly Disagree

Average Response: 2.00

A sampling of written Comments from the student's survey are also included below:

1. "I can't stress the importance of relevant flight test experience. I go out of my way to find students that have had the VT or [another] flight test class because of the knowledge and experience gained by the students. From the basics of how to develop a test to the specifics of what actually occurs during a flight, the flight test course exposes students to the skill set necessary to excel at [ORG-X]. [ORG-X] has spoken with several universities in the past and encouraged their engineering departments to incorporate a class similar to the VT flight test class. It would be a shame to lose that competitive edge that VT grads have with [ORG-X]."

2. “The AOE4984 curriculum clearly prepared my employee for the avionic systems work that he was hired for. He came in with surprising breadthwise knowledge and was hungry to dig into the more complex and ambiguous problems our engineers are challenged with in the industry.”
3. “This gives the new hire a leg up in bridging the gap between theory and practice. This has taken some load off of me and our senior leads.”