

Pierre-Étienne Druet

Existence for the stationary MHD-equations coupled to heat transfer with nonlocal radiation effects

Czechoslovak Mathematical Journal, Vol. 59 (2009), No. 3, 791–825

Persistent URL: <http://dml.cz/dmlcz/140517>

Terms of use:

© Institute of Mathematics AS CR, 2009

Institute of Mathematics of the Czech Academy of Sciences provides access to digitized documents strictly for personal use. Each copy of any part of this document must contain these *Terms of use*.



This document has been digitized, optimized for electronic delivery and stamped with digital signature within the project *DML-CZ: The Czech Digital Mathematics Library* <http://dml.cz>

EXISTENCE FOR THE STATIONARY MHD-EQUATIONS COUPLED
TO HEAT TRANSFER WITH NONLOCAL RADIATION EFFECTS

PIERRE-ÉTIENNE DRUET, Berlin

(Received March 10, 2008)

Abstract. We consider the problem of influencing the motion of an electrically conducting fluid with an applied steady magnetic field. Since the flow is originating from buoyancy, heat transfer has to be included in the model. The stationary system of magnetohydrodynamics is considered, and an approximation of Boussinesq type is used to describe the buoyancy. The heat sources given by the dissipation of current and the viscous friction are not neglected in the fluid. The vessel containing the fluid is embedded in a larger domain, relevant for the global temperature- and magnetic field- distributions. Material inhomogeneities in this larger region lead to transmission relations for the electromagnetic fields and the heat flux on inner boundaries. In the presence of transparent materials, the radiative heat transfer is important and leads to a nonlocal and nonlinear jump relation for the heat flux. We prove the existence of weak solutions, under the assumption that the imposed velocity at the boundary of the fluid remains sufficiently small.

Keywords: nonlinear elliptic system, magnetohydrodynamics, natural interface conditions, nonlinear heat equation, nonlocal radiation boundary conditions

MSC 2010: 35J55, 35Q35, 35Q30, 35Q60

INTRODUCTION

The possibility to exert control on the motion of electrically conducting fluids with the help of magnetic fields is well known. An industrial area in which this idea is applied nowadays is crystal growth from the melt, where thermally unstable melt flows result in a loss of quality for the production. The use of magnetic fields in similar contexts leads to complex processes in which hydrodynamic, electromagnetic, and thermodynamic phenomena closely interact with each other. The attempt to accurately model such phenomena results in strongly coupled systems of PDE, for which few mathematical results have been stated.

In this paper, we prove the existence of weak solutions to the system consisting of the Navier-Stokes equations for a viscous, electrically conducting, heat conducting fluid in the Boussinesq approximation, the Maxwell equations for linear media, and the heat equation with nonlocal radiation effects. The most important feature of the paper in comparison to available results (cf. [16]) is that the heat radiation and the complex geometrical settings given in applications are included in the theory, as well as the dissipative heat sources.

Geometrical setting. We are interested in the temperature distribution in a high temperatures furnace, in the velocity of the flow of a liquid occupying a vessel contained in the furnace, and in the influence of applied magnetic fields on both phenomena. It is seldom realistic to assume that the magnetic field is confined to the region of interest. Therefore, the electromagnetic fields are searched in a “hold all” region, which is larger than the furnace.

We consider disjoint bounded domains $\tilde{\Omega}_0, \dots, \tilde{\Omega}_m \subset \mathbb{R}^3$ ($m \geq 1$), such that the set defined by $\overline{\tilde{\Omega}} := \bigcup_{i=0}^m \overline{\tilde{\Omega}_i}$ is simply connected, and represents the region in which the electromagnetic fields are acting. The domains $\tilde{\Omega}_i$ represent the different materials filling the region. We denote by $\Omega \subseteq \tilde{\Omega}$ the bounded domain of interest for temperature distribution, typically the furnace. Defining $\Omega_i := \tilde{\Omega}_i \cap \Omega$, we have $\overline{\Omega} := \bigcup_{i=0}^m \overline{\Omega_i}$. An example for the region Ω is given in Figure 1.

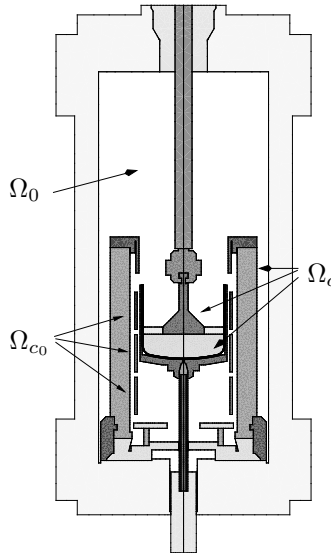

Figure 1. An example for the region Ω : schematic representation of a growth arrangement of the Institute of Crystal Growth (IKZ) Berlin. The transparent cavity Ω_0 , the coils Ω_{c0} , and some of the electrically conducting materials are indicated by arrows.

A subdomain of Ω is occupied by the liquid. We denote this region by Ω_1 . We further denote by $\tilde{\Omega}_c \subseteq \tilde{\Omega}$ the region occupied by electrically conducting materials, and by $\tilde{\Omega}_{c_0} \subseteq \tilde{\Omega}_c$ the region where a current source is acting, typically a magnetic coil. We set $\Omega_c := \tilde{\Omega}_c \cap \Omega$, and define Ω_{c_0} analogously. The set $\tilde{\Omega}_{nc}$ is occupied by electrically nonconducting materials. We set $\Gamma := \partial\Omega$.

Due to the importance of the radiative heat transfer, we have to distinguish between opaque and transparent materials. One of the different subdomains of the region Ω , say Ω_0 , represents an *enclosed cavity* filled with a transparent material. The remaining materials $\Omega_1, \dots, \Omega_m$ are assumed to be opaque, and we define $\overline{\Omega_{\text{op}}} := \bigcup_{i=1}^m \overline{\Omega_i}$. The *enclosure property* is satisfied, meaning that

$$(1) \quad \mathbb{R}^3 \setminus \Omega_{\text{op}} \text{ is disconnected.}$$

At the boundary of the transparent cavity, heat radiation is emitted, reflected and absorbed. We denote by $\Sigma := \partial\Omega_0$ this boundary.

The mathematical model. In the domain $\tilde{\Omega}$, we consider the following system of partial differential equations

$$(2) \quad \varrho_1(v \cdot \nabla)v = -\nabla p + \text{div}(2\eta(\theta)Dv) + f(\theta) + j \times B \quad \text{in } \Omega_1,$$

$$(3) \quad \text{div } v = 0 \quad \text{in } \Omega_1,$$

$$(4) \quad f(\theta) = \varrho(\theta)\vec{g} := \varrho_1(1 - \alpha(\theta - \theta_1)) \quad \text{in } \Omega_1,$$

$$(5) \quad \varrho_1 c_V v \cdot \nabla \theta = \text{div}(\kappa(\theta)\nabla\theta) + 2\eta(\theta)D(v, v) + \frac{|j|^2}{\mathfrak{s}(\theta)} \quad \text{in } \Omega,$$

$$(6) \quad \text{curl } H = j \quad \text{in } \tilde{\Omega},$$

$$(7) \quad \text{curl } E = 0 \quad \text{in } \tilde{\Omega},$$

$$(8) \quad \text{div } B = 0 \quad \text{in } \tilde{\Omega},$$

$$(9) \quad j = \begin{cases} 0 & \text{in } \tilde{\Omega}_{nc}, \\ j_0 & \text{in } \tilde{\Omega}_{c_0}, \\ \mathfrak{s}(\theta)(E + v \times B) & \text{in } \tilde{\Omega}_c \setminus \tilde{\Omega}_{c_0}, \end{cases}$$

$$(10) \quad \text{div } D = 0 \quad \text{in } \tilde{\Omega} \setminus \tilde{\Omega}_c,$$

$$(11) \quad B = \mu H, \quad D = \epsilon E \quad \text{in } \tilde{\Omega},$$

with

Unknowns

v fluid velocity

p fluid pressure

Parameters

ϱ_1 reference mass density of the fluid

η dynamic viscosity

θ absolute temperature	α coefficient of thermal expansion
E electric field strength	θ_1 reference temperature of the fluid
B magnetic induction	c_V specific heat
H magnetic field strength	κ heat conductivity
j electric current density	\mathfrak{s} electrical conductivity
D displacement current	μ magnetic permeability
	ϵ electrical permittivity.

For the rate of strain, we have used the notation

$$Dv = D_{i,j}(v) := \frac{1}{2} \left(\frac{\partial v_i}{\partial x_j} + \frac{\partial v_j}{\partial x_i} \right) \quad (i, j = 1, \dots, 3),$$

and have set

$$D(u, v) := Du : Dv := D_{i,j}(u) D_{i,j}(v),$$

with the convention that repeated indices imply summation over 1, 2, 3.

The relations (2), (3), (4) are known as Boussinesq's approximation of compressible fluids (see [7] for a general description). This approximation is in general well accepted for the study of thermal convection in liquids (cf. [2], II. 1. 8), and for applications in crystal growth from the melt (see e.g. [20]). According to Boussinesq's ideas, the liquid can be regarded as incompressible in the mean (3), and thermal expansion is significant only at the level of the gravitational force (4).

As to the gravitational force $f: \mathbb{R} \rightarrow \mathbb{R}^3$ given by (4), we note that $\varrho_1 \vec{g} = \nabla \mathcal{G}$ with a scalar potential \mathcal{G} . Therefore, we can as well solve the problem with a corrected pressure $\tilde{p} := p + \mathcal{G}$, and the force

$$(12) \quad f(\theta) = -\varrho_1 \vec{g} \alpha (\theta - \theta_M),$$

where for the reference temperature θ_1 , we have chosen the mean value θ_M of the temperature over the set Ω_1 . Since the liquid is electrically conducting, the Lorentz force $j \times B$ has to be taken into account.

The relation (5) accounts for heat conduction and convection in Ω . Observe that $v \neq 0$ only in the set Ω_1 . The heat sources are given by the Joule effect and the viscous friction localized in the fluid.

The relations (6), (7), (8), and (9) are respectively known as Ampère's law, Faraday's law, Gauss law, and Ohm's law. In the conductors $\tilde{\Omega}_{c_0}$, the density j_0 of an applied direct current is given. The requirement (10) is a consequence of charge conservation in the absence of free charges. Finally, (11) are the constitutive relations characterizing linear media. The use of this type of model for the electromagnetic part of the problem is justified in the reference [1].

The boundary conditions. We consider the following boundary conditions

$$(13) \quad v = v_0 \quad \text{on } \partial\Omega_1,$$

$$(14) \quad \left[-\kappa(\theta) \frac{\partial\theta}{\partial\vec{n}} \right] = R - J \quad \text{on } \Sigma,$$

$$(15) \quad R = \varepsilon\sigma|\theta|^3\theta + (1 - \varepsilon)J, \quad \text{on } \Sigma,$$

$$(16) \quad J = K(R) \quad \text{on } \Sigma,$$

$$(17) \quad \theta = \theta_0 \quad \text{on } \Gamma,$$

$$(18) \quad [H \times \vec{n}]_{i,j} = 0, \quad [B \cdot \vec{n}]_{i,j} = 0, \quad [E \times \vec{n}]_{i,j} = 0 \quad \text{on } \partial\tilde{\Omega}_i \cap \partial\tilde{\Omega}_j,$$

$$(19) \quad B \cdot \vec{n} = 0, \quad E \times \vec{n} = 0 \quad \text{on } \partial\tilde{\Omega}.$$

The velocity is imposed at the boundary of the fluid (13), typically by the rotation of the axisymmetric vessel, where it is contained.

The jump of a quantity across a surface is denoted with square brackets. At the boundary of the transparent cavity Σ , the conductive heat flux has a discontinuity (14) equal to the difference between the heat radiation outgoing from the surface, denoted by R , and the heat radiation incoming at the surface, denoted by J . We follow the approach of [11], standard in crystal growth, to model the quantities R and J . The main assumption is that all the opaque materials involved are *diffuse grey*, so that their emission properties do not depend on the wavelength of the radiation. Semitransparent materials are excluded.

The relation (15) expresses that the outgoing radiation R is the sum of the radiation emitted according to the Stefan-Boltzmann law, and of the reflected part of the incoming radiation. The function ε is given and called the *emissivity* ($1 - \varepsilon$ is the *reflexivity*) of the surface Σ and attains values in $[0, 1]$. The Stefan-Boltzmann constant is denoted by σ .

Outgoing radiation and incoming radiation are connected by the nonlocal constitutive relation (16). The linear integral operator K is defined by

$$(20) \quad (K(R))(z) := \int_{\Sigma} w(z, y)R(y) \, dS_y \quad \text{for } z \in \Sigma,$$

where $w: \Sigma \times \Sigma \rightarrow \mathbb{R}$, called the *view factor*, is given by

$$(21) \quad w(z, y) := \begin{cases} \frac{\vec{n}(z) \cdot (y - z)\vec{n}(y) \cdot (z - y)}{\pi|y - z|^4} \Theta(z, y) & \text{if } z \neq y, \\ 0 & \text{if } z = y, \end{cases}$$

and where Θ is the *visibility function* that penalizes the presence of opaque obstacles in the cavity Ω_0

$$\Theta(z, y) = \begin{cases} 1 & \text{if }]z, y[\subset \Omega_0, \\ 0 & \text{otherwise.} \end{cases}$$

By the symbol $]z, y[$, we denote the set $\text{conv}\{z, y\} \setminus \{z, y\}$, and \vec{n} is a unit normal to Σ .

Note that the relations (15) and (16) are equivalent to the *radiosity equation*

$$(I - (1 - \varepsilon)K)(R) = \varepsilon\sigma|\theta|^3\theta \quad \text{on } \Sigma,$$

where I denotes the identity mapping. Under mild assumptions on the geometry and on the emissivity ε (cf. Lemma C.2, (3)), the solution operator $(I - (1 - \varepsilon)K)^{-1}$ is well defined. Introducing then another linear operator

$$(22) \quad G := (I - K)(I - (1 - \varepsilon)K)^{-1}\varepsilon,$$

we can equivalently reformulate (14), (15), (16) in the single relation

$$(23) \quad \left[-\kappa(\theta)\frac{\partial\theta}{\partial\vec{n}} \right] = G(\sigma|\theta|^3\theta) \quad \text{on } \Sigma,$$

where only the unknown θ is involved.

The condition (17) does not need further comment. At interfaces between opaque materials, we simply assume the continuity of the conductive heat flux.

The boundary conditions (18) are the natural interface conditions for the electromagnetic fields. The conditions (19) at the outer boundary model the behavior of the electromagnetic fields at perfectly conducting boundaries. They may be used either to model a magnetic shield, or as an approximation of the condition of vanishing at infinity.

Definition 0.1. We will address the problem of finding fields v, H, B, E, D, j and scalars p, θ that satisfy (2), (3), (12), (13), (5), (17), (23), (6), (7), (8), (9), (10), (11), (18), and (19), as Problem (P).

State of the research. The paper [15] provides a nice survey about recent developments in the mathematical theory of MHD. The main difficulty for the functional-analytic method is to control the growth of the term $j \times B$. In view of Ampère's law (6) and (11), we can write $j \times B = \text{curl} H \times \mu H$, and we see that in the natural setting of Maxwell equations, the latter term belongs *a priori* only to L^1 (see [4] for a discussion of this question).

All the results available on the MHD system are based on the fact that the vector field H that weakly solves Maxwell equations in $\tilde{\Omega}$ belongs to the Sobolev space $W^{1,2}(\tilde{\Omega})$, provided that the magnetic permeability μ is smooth in each subdomain, and that the interfaces $\partial\tilde{\Omega}_i \cap \partial\tilde{\Omega}_j$ ($i, j = 0, \dots, m$) belong to \mathcal{C}^2 (see, among others, [13], [3], or [15] for a proof of this result).

The coupling of the heat equation to the Navier-Stokes equations (*heat conductive fluids*) or to the stationary Maxwell equations (*resistive heating*) leads in complex situations to heat-sources in L^1 , resp. in $L^{1+\varepsilon}$. Stronger integrability of the viscous dissipation $D(v, v)$ (resp. of $|\operatorname{curl} H|^2$) can be obtained in the Navier-Stokes equations only for smooth boundaries and coefficients, which is very restricting with respect to the covered class of applications. A summary of recent results concerning the coupling of the stationary, incompressible Navier-Stokes equations to the heat equation and techniques for handling systems with L^1 -right-hand sides can be found in [17].

The existence theory that we propose therefore extends existing results in the following respects

1. We consider the full system consisting of the Navier-Stokes equations for a viscous, electrically conducting, heat conducting fluid in the Boussinesq approximation, Maxwell system for linear media, and the heat equation in complex geometries.
2. Under suitable assumptions on the magnetic permeability μ , we allow for a larger class of interfaces between materials with heterogeneous electromagnetic properties.
3. Nonlocal radiation effects are included.

Our plan is as follows. In the section 1, we introduce the functional setting and we define what we will call a weak solution. The section 2 is devoted to the main results: in Theorem 2.1 an existence result for the case that the temperature-dependent force term in the fluid equation is bounded, and in Theorem 2.7 an existence result for the genuine Boussinesq model under a smallness assumption on the coefficient of thermal expansion of the fluid. In the appendix, we have recalled auxiliary results needed throughout the paper.

1. DEFINITION OF A WEAK SOLUTION

In order to define a weak solution, we at first need to make assumptions concerning the coefficients, the geometry, and the data of Problem (P) .

The coefficients of electrical conductivity, of magnetic permeability, and of heat conductivity are material-dependent. We introduce the abbreviations

$$(24) \quad \mathfrak{s} := \mathfrak{s}_i, \quad \mu := \mu_i, \quad \kappa := \kappa_i \quad \text{in each } \tilde{\Omega}_i \text{ for } i = 0, \dots, m.$$

Throughout the paper, we assume that there exist positive constants $\mathfrak{s}_l, \mathfrak{s}_u, \mu_l, \mu_u, \kappa_l, \kappa_u, \eta_l, \eta_u$ such that

$$(25) \quad \begin{aligned} 0 < \mathfrak{s}_l \leq \mathfrak{s} \leq \mathfrak{s}_u < +\infty, & \quad 0 < \mu_l \leq \mu \leq \mu_u < +\infty, \\ 0 < \kappa_l \leq \kappa \leq \kappa_u < +\infty, & \quad 0 < \eta_l \leq \eta \leq \eta_u < +\infty. \end{aligned}$$

The emissivity of the surface Σ , denoted by ε , is a function of the position. We assume that $\varepsilon: \Sigma \rightarrow \mathbb{R}$ is measurable and that there exists a positive number ε_l such that

$$(26) \quad 0 < \varepsilon_l \leq \varepsilon_i < 1 \quad \text{on } \partial\Omega_i \cap \Sigma \text{ for } i = 0, \dots, m.$$

For the temperature-dependent coefficients, we require that

$$(27) \quad \mathfrak{s}_i, \kappa_i, \eta \in C(\mathbb{R}) \quad \text{for } i = 0, \dots, m.$$

For other coefficients, we also require the continuity in each material

$$(28) \quad \mu_i \in C(\overline{\tilde{\Omega}_i}), \quad \varepsilon_i \in C(\partial\Omega_i \cap \Sigma).$$

The parameters $\alpha, \varrho_1, \theta_1, c_V$ are assumed to be positive constants. For the sake of notational commodity, we introduce the auxiliary function of electric resistivity, that we extend by one to the nonconductors

$$(29) \quad r := \begin{cases} \frac{1}{\mathfrak{s}} & \text{on } \tilde{\Omega}_c, \\ 1 & \text{on } \tilde{\Omega}_{nc}, \end{cases} \quad r_l := \mathfrak{s}_u^{-1}, \quad r_u := \mathfrak{s}_l^{-1}.$$

We now formulate a few assumptions on the geometry. In order to ensure the fundamental properties of Lemma C.1, we assume that the surface Σ belongs to C^1 piecewise.

In order to ensure the higher integrability of the Lorentz force, we assume either that

$$(30) \quad \partial\tilde{\Omega}_i \in C^1, \quad \text{for } i = 0, \dots, m, \quad \partial\tilde{\Omega} \in C^{0,1}.$$

or that

$$(31) \quad C(1 - \mu_l/\mu_u) < 1,$$

with the constant C of Lemma A.1, (4), and the constants μ_l, μ_u of (25).

Finally, we formulate a few assumptions on the data v_0, θ_0, j_0 . We require the regularity

$$(32) \quad v_0 \in [L^\infty(\partial\Omega_1)]^3, \quad \theta_0 \in L^\infty(\Gamma), \quad j_0 \in [L^2(\tilde{\Omega}_{c_0})]^3.$$

The velocity v_0 imposed at the boundary of the fluid has to satisfy

$$(33) \quad v_0 \cdot \vec{n} = 0 \quad \text{on } \partial\Omega_1,$$

since Ω_1 is assumed to be bounded by fixed walls.

We assume the conductors of $\tilde{\Omega}_{c_0}$, that supply the current, are modeled as closed current loops. For the density of the applied direct current, we make the consistency assumptions that

$$(34) \quad \operatorname{div} j_0 = 0 \text{ in } \tilde{\Omega}_{c_0}, \quad j_0 \cdot \vec{n} = 0 \text{ on } \partial\tilde{\Omega}_{c_0}.$$

We also need to introduce some functional spaces. In the context of the generalized theory of electromagnetics, we need the space

$$L^2_{\operatorname{curl}}(\tilde{\Omega}) := \{H \in [L^2(\tilde{\Omega})]^3 \mid \operatorname{curl} H \in [L^2(\tilde{\Omega})]^3\},$$

where the differential operator curl is meant in its generalized sense. It is well known that the space $L^2_{\operatorname{curl}}(\tilde{\Omega})$ is a Hilbert space with respect to the scalar product

$$(H_1, H_2)_{L^2_{\operatorname{curl}}(\tilde{\Omega})} := \int_{\tilde{\Omega}} (\operatorname{curl} H_1 \cdot \operatorname{curl} H_2 + H_1 \cdot H_2).$$

Actually, in view of (9), the natural frame in which to search for the field H will be the space

$$(35) \quad \mathcal{H}(\tilde{\Omega}) := \{H \in L^2_{\operatorname{curl}}(\tilde{\Omega}) \mid \operatorname{curl} H = 0 \text{ in } \tilde{\Omega} \setminus \tilde{\Omega}_c\}.$$

If μ is given by (24) and satisfies (25), it is possible to deal with the divergence constraint (8) and the boundary conditions (18) by introducing

$$(36) \quad \mathcal{H}_\mu(\tilde{\Omega}) := \{H \in \mathcal{H}(\tilde{\Omega}) \mid \operatorname{div}(\mu H) = 0 \text{ in } \tilde{\Omega}; \mu H \cdot \vec{n} = 0 \text{ on } \partial\tilde{\Omega}\},$$

where the divergence constraint is meant in the generalized sense of the operator div. We will also need the spaces

$$(37) \quad \mathcal{H}^0(\tilde{\Omega}) := \{H \in \mathcal{H}(\tilde{\Omega}) \mid \operatorname{curl} H = 0 \text{ in } \tilde{\Omega}_{c_0}\},$$

$$(38) \quad \mathcal{H}_\mu^0(\tilde{\Omega}) := \{H \in \mathcal{H}_\mu(\tilde{\Omega}) \mid \operatorname{curl} H = 0 \text{ in } \tilde{\Omega}_{c_0}\}.$$

In the context of the Navier-Stokes equations, we need the spaces

$$(39) \quad \begin{aligned} D^{1,2}(\Omega_1) &:= \{u \in [W^{1,2}(\Omega_1)]^3 \mid \operatorname{div} u = 0 \text{ almost everywhere in } \Omega_1\}, \\ D_0^{1,2}(\Omega_1) &:= \{u \in [W_0^{1,2}(\Omega_1)]^3 \mid \operatorname{div} u = 0 \text{ almost everywhere in } \Omega_1\}. \end{aligned}$$

For the mathematical setting of the stationary heat equation with radiation boundary condition, we need the space

$$(40) \quad V^{p,q}(\Omega) := \{\theta \in W^{1,p}(\Omega) | \gamma(\theta) \in L^q(\Sigma)\}, \quad 1 \leq p \leq \infty, \quad 4 \leq q \leq \infty,$$

which is a Banach space with respect to the norm $\|\cdot\|_{W^{1,p}(\Omega)} + \|\gamma(\cdot)\|_{L^q(\Sigma)}$, where γ denotes the trace operator. The subscript Γ will indicate the subspace consisting of all functions whose trace vanishes on the boundary part Γ .

Definition 1.1. Let the assumptions (25), (26), (27), (28) on the coefficients η , \mathfrak{s} , μ , κ , ε be satisfied. Let $\Sigma \in \mathcal{C}^1$ piecewise, and let the geometry satisfy either (30) or (31). Assume that v_0, θ_0, j_0 satisfy (32), and that j_0 satisfies (34). We call *weak solution* to (P) a triple

$$\{v, H, \theta\} \in D^{1,2}(\Omega_1) \times \mathcal{H}_\mu(\tilde{\Omega}) \times \bigcap_{1 \leq p < 3/2} V^{p,4}(\Omega),$$

such that $v = v_0$ on $\partial\Omega_1$, $\theta = \theta_0$ on Γ , $\theta \geq 0$ in Ω , $\text{curl } H = j_0$ in $\tilde{\Omega}_{c_0}$ and the integral relations

$$(41) \quad \int_{\Omega_1} \varrho_1(v \cdot \nabla)v \cdot \varphi + \int_{\Omega_1} \eta(\theta)D(v, \varphi) = \int_{\Omega_1} (\text{curl } H \times \mu H) \cdot \varphi + \int_{\Omega_1} f(\theta) \cdot \varphi,$$

$$(42) \quad \int_{\tilde{\Omega}} r(\theta) \text{curl } H \cdot \text{curl } \psi = \int_{\Omega_1} (v \times \mu H) \cdot \text{curl } \psi,$$

$$(43) \quad \int_{\Omega_1} \varrho_1 c_V v \cdot \nabla \theta \xi + \int_{\Omega} \kappa(\theta) \nabla \theta \cdot \nabla \xi + \int_{\Sigma} G(\sigma \theta^4) \xi \\ = \int_{\Omega} r(\theta) |\text{curl } H|^2 \xi + \int_{\Omega_1} \eta(\theta) D(v, v) \xi,$$

are satisfied for all $\{\varphi, \psi, \xi\} \in D_0^{1,2}(\Omega) \times \mathcal{H}_\mu^0(\tilde{\Omega}) \times W_{\Gamma}^{1,\bar{r}}(\Omega)$ with $\bar{r} > 3$.

Remark 1.2 (Well-posedness of Definition 1.1). The assumption (30) or (31) ensures, in view of Lemma A.1, (3) or (4), that

$$(44) \quad \text{curl } H \times \mu H \in [L^{6/5}(\tilde{\Omega})]^3.$$

The assumption (26), together with the regularity $\Sigma \in \mathcal{C}^1$ piecewise, ensures that the definition (22) of the radiation operator G is well posed, and that G is continuous form $L^1(\Sigma)$ into itself (cp. Lemma C.2, (1) and (3)).

The well-posedness of definition 1.1 is therefore readily checked.

2. EXISTENCE RESULTS

We introduce some notations. We denote by c_{Korn} and $c_{\mathcal{H}}$ the smallest positive constants such that for all $v \in D_0^{1,2}(\Omega_1)$ and all $\psi \in \mathcal{H}_\mu(\tilde{\Omega})$,

$$\int_{\Omega_1} |\nabla v|^2 \leq c_{\text{Korn}} \int_{\Omega_1} D(v, v), \quad \|\psi\|_{[L^2(\tilde{\Omega})]^3}^2 \leq c_{\mathcal{H}} \int_{\tilde{\Omega}} |\text{curl } \psi|^2.$$

The existence of the constant $c_{\mathcal{H}}$ is granted in view of Lemma A.1. In our estimates, we will use the abbreviations $\mathbf{v}_0 := \max_{\partial\Omega_1} |v_0|$ and $L := \text{diam}(\Omega_1)$.

For a function $g: \tilde{\Omega} \rightarrow \mathbb{R}$ and $\delta \in \mathbb{R}^+$, we introduce the cutoff

$$(45) \quad [g]_{(\delta)} := \frac{g}{1 + \delta|g|}.$$

For the existence theorem, we need additional, reinforced assumptions on the data of the problem. We assume that the velocity imposed at the boundary of the fluid v_0 has an extension to Ω_1 . Still denoting by v_0 this extension, we assume that $v_0 \in D^{1,2}(\Omega_1)$ satisfies the smallness assumption

$$(46) \quad \mathbf{v}_0 < c \min \left\{ \frac{\eta_l}{\varrho_1 L}, \frac{r_l}{2\mu_u} \right\},$$

with $c := \min\{c_{\text{Korn}}^{-1}, c_{\mathcal{H}}^{-1}\}$. If (46) is valid, we can define the positive number

$$(47) \quad \gamma_0 := \min\{\eta_l - c_{\text{Korn}}\varrho_1\mathbf{v}_0L, r_l - 2c_{\mathcal{H}}\mu_u\mathbf{v}_0\}.$$

We will need the geometrical assumption

$$(48) \quad \Sigma \in \mathcal{C}^{1,\alpha}, \quad \text{for a } 0 < \alpha \leq 1,$$

which ensures compactness properties of the nonlocal radiation operators (Lemma C.3 and C.5), and for the homogenization of the condition (17), we need the assumption

$$(49) \quad \text{dist}(\Gamma, \Sigma) > 0.$$

Note that the Boussinesq relations (3), (4) disturb the global energy balance of the system, since in general the work

$$\int_{\Omega_1} \varrho(\theta)\vec{g} \cdot v,$$

does not vanish for solenoidal vector fields v . We propose two ways to obtain a global energy estimate. In the section 2.1, we replace the force term f in (12) by

$$(50) \quad f = -\varrho_1 \vec{g} \operatorname{sign}(\theta - \theta_M) \min\{\alpha|\theta - \theta_M|, M_t\},$$

with a positive number M_t . The term $\alpha(\theta - \theta_M)$ represents the density variations in the liquid. This quantity has to remain small compared to unity for the Boussinesq model to make sense. Therefore, M_t that can be interpreted as the maximum of density variation allowed by the model. In the section 2.1, we thus have

$$(51) \quad \max_{\mathbb{R}} |f| \leq \varrho_1 |\vec{g}| M_t < \infty.$$

In the section 2.2, we treat the more complicated case (12) and obtain the global energy estimate thanks to a smallness assumption on the coefficient α . Note that in the case of a complete Boussinesq approximation, that is, the case that the dissipative heating is neglected in the fluid, to control the linear growth of $f(\theta)$ means no particular difficulty (e.g. [16]).

2.1. Truncated buoyancy forces. Our main result in this section is the following theorem.

Theorem 2.1. *Assume that the conditions of Definition 1.1 are satisfied. Assume in addition that the surface Σ has the smoothness (48) and the property (49), that the boundary data $v_0 \in D^{1,2}(\Omega_1) \cap L^\infty(\Omega_1)$ satisfies the smallness assumption (46), and that the force term f has the property (51).*

Then, there exists at least one weak solution of (P) in the sense of Definition 1.1.

The remainder of the section is devoted to the proof of Theorem 2.1. We first regularize the problem to construct approximate solutions (Proposition 2.2). In Proposition 2.3, we derive uniform estimates, and in Proposition 2.4 compactness properties of the approximating sequence. Passage to the limit is carried over at the end of the section.

Proposition 2.2. *Let $\delta > 0$ be an arbitrary positive number. If the assumptions of Theorem 2.1 are satisfied, there exists a triple*

$$\{v, H, \theta\} \in D^{1,2}(\Omega_1) \times \mathcal{H}_\mu(\tilde{\Omega}) \times V^{2,5}(\Omega),$$

such that $v = v_0$ on $\partial\Omega_1$, $\theta = \theta_0$ on Γ , $\operatorname{curl} H = j_0$ in $\tilde{\Omega}_{c_0}$ and such that the relations

$$(52) \quad \int_{\Omega_1} \varrho_1 (v \cdot \nabla) v \cdot \varphi + \int_{\Omega_1} \eta(\theta) D(v, \varphi) = \int_{\Omega_1} (\operatorname{curl} H \times \mu H) \cdot \varphi + \int_{\Omega_1} f(\theta) \cdot \varphi,$$

$$(53) \quad \int_{\tilde{\Omega}} r(\theta) \operatorname{curl} H \cdot \operatorname{curl} \psi = \int_{\Omega_1} (v \times \mu H) \cdot \operatorname{curl} \psi,$$

$$(54) \quad \int_{\Omega_1} \varrho_1 c_V v \cdot \nabla \theta \xi + \int_{\Omega} \kappa(\theta) \nabla \theta \cdot \nabla \xi + \int_{\Sigma} G(\sigma \theta^4) \xi \\ = \int_{\Omega} [r(\theta) |\operatorname{curl} H|^2 + \eta(\theta) D(v, v) \chi_{\Omega_1}]_{(\delta)} \xi,$$

are satisfied for all $\{\varphi, \psi, \xi\} \in D_0^{1,2}(\Omega_1) \times \mathcal{H}_\mu^0(\tilde{\Omega}) \times V_\Gamma^{2,5}(\Omega)$. In addition,

$$(55) \quad \theta \geq \operatorname{ess\,inf}_\Gamma \theta_0 \quad \text{almost everywhere in } \Omega.$$

Proof. First, we need to introduce some additional notations. For vector fields $v \in D_0^{1,2}(\Omega_1)$, we use the notation

$$(56) \quad \hat{v} := v + v_0.$$

Thanks to the assumption (49), we can fix some $\varphi_0 \in C^\infty(\bar{\Omega})$ such that $\varphi_0 = 1$ on Γ and $\varphi_0 = 0$ on Σ . For $\theta \in V_\Gamma^{2,5}(\Omega)$, we introduce the notation

$$(57) \quad \hat{\theta} := \theta + \theta_0 \varphi_0.$$

In this way, we homogenize the problem for the temperature without perturbing the nonlocal terms on Σ . Given a current density j_0 with (34), (5), we can find by Lemma A.1 some $H_0 \in \mathcal{H}_\mu(\tilde{\Omega})$ such that

$$(58) \quad \operatorname{curl} H_0 = j_0 \text{ in } \tilde{\Omega}.$$

For vector fields $H \in \mathcal{H}_\mu^0(\tilde{\Omega})$, we then define a reaction field

$$(59) \quad \hat{H} := H + H_0.$$

Define $V := D_0^{1,2}(\Omega_1) \times \mathcal{H}_\mu^0(\tilde{\Omega}) \times V_\Gamma^{2,5}(\Omega)$. Then, the isomorphism

$$V^* \cong [D_0^{1,2}(\Omega_1)]^* \times [\mathcal{H}_\mu^0(\tilde{\Omega})]^* \times [V_\Gamma^{2,5}(\Omega)]^*$$

is valid. Throughout this proof, we denote by $\langle \cdot, \cdot \rangle$ the duality pairing between V and V^* . Recalling the notations (56), (57), (59) and (45), we define an operator $A: V \rightarrow V^*$ by

$$\begin{aligned} \langle A(\{v, H, \theta\}), \{\varphi, \psi, \xi\} \rangle &:= \int_{\Omega_1} \varrho_1(\hat{v} \cdot \nabla) \hat{v} \cdot \varphi + \int_{\Omega_1} \eta(\hat{\theta}) D(\hat{v}, \varphi) \\ &- \int_{\Omega_1} (\operatorname{curl} \hat{H} \times \mu \hat{H}) \cdot \varphi - \int_{\Omega_1} f(\hat{\theta}) \cdot \varphi + \int_{\tilde{\Omega}} r(\hat{\theta}) \operatorname{curl} \hat{H} \cdot \operatorname{curl} \psi \\ &- \int_{\Omega_1} (\hat{v} \times \mu \hat{H}) \cdot \operatorname{curl} \psi + \int_{\Omega_1} \varrho_1 c_V \hat{v} \cdot \nabla \hat{\theta} \xi + \int_{\Omega} \kappa(\hat{\theta}) \nabla \hat{\theta} \cdot \nabla \xi \\ &+ \int_{\Sigma} G(\sigma |\hat{\theta}|^3 \hat{\theta}) \xi - \int_{\Omega} [r(\hat{\theta}) |\operatorname{curl} \hat{H}|^2 + \eta(\hat{\theta}) D(\hat{v}, \hat{v}) \chi_{\Omega_1}]_{(\delta)} \xi. \end{aligned}$$

Note that using the results of Lemma A.1, (3) or (4) we have under the assumption (30) or (31) that the embedding $\mathcal{H}_\mu(\tilde{\Omega}) \hookrightarrow [L^q(\tilde{\Omega})]^3$ is valid for some $q > 3$. Using Hölder's inequality, we can therefore prove under the assumptions of Theorem 2.1 that A is well defined, and maps bounded sets of V into bounded sets of V^* .

We want to use the well-known fact that the coercivity and the pseudomonotonicity of the operator A are sufficient for the surjectivity in reflexive, separable Banach spaces. Since this type of proof has become fairly standard (cp. for instance [17]), we only give the main ideas.

We at first discuss the coercivity. Observe that

$$\int_{\Omega_1} \varrho_1(\hat{v} \cdot \nabla) v \cdot v = \int_{\Omega_1} \varrho_1 \hat{v}_j \frac{1}{2} \frac{\partial}{\partial x_j} v_i^2 = 0,$$

since $v \in D_0^{1,2}(\Omega_1)$, and since v_0 is divergence free in Ω_1 and tangential on $\partial\Omega_1$. For the same reasons, the heat convection $\int_{\Omega_1} \varrho_1 c_V \hat{v} \cdot \nabla \theta$ vanishes as well. It follows that

$$\begin{aligned} \int_{\Omega_1} \varrho_1(\hat{v} \cdot \nabla) \hat{v} \cdot v &= \int_{\Omega_1} \varrho_1 ((v \cdot \nabla) v_0 + (v_0 \cdot \nabla) v_0) \cdot v \\ (60) \qquad \qquad \qquad &= - \int_{\Omega_1} \varrho_1 (v_j v_{0,i} + v_{0,i} v_{0,j}) \frac{\partial v_i}{\partial x_j}. \end{aligned}$$

Thus, by Poincaré's and Young's inequality, we find the estimate

$$\begin{aligned} \left| \int_{\Omega_1} \varrho_1(\hat{v} \cdot \nabla) \hat{v} \cdot v \right| &\leq \varrho_1(\mathbf{v}_0 L \|\nabla v\|_{[L^2(\Omega_1)]^9} + \mathbf{v}_0^2 \operatorname{meas}(\Omega_1)^{1/2}) \|\nabla v\|_{[L^2(\Omega_1)]^9} \\ &\leq (\varrho_1 \mathbf{v}_0 L + \gamma) \|\nabla v\|_{[L^2(\Omega_1)]^9}^2 + \frac{\varrho_1^2 \mathbf{v}_0^4 \operatorname{meas}(\Omega_1)}{4\gamma}, \end{aligned}$$

where γ is an arbitrary small, positive number. We also consider the estimate

$$\begin{aligned} \left| \int_{\Omega_1} (v_0 \times \mu \widehat{H}) \cdot \operatorname{curl} H \right| &\leq 2\mathbf{v}_0 \mu_u \|H\| + H_0 \|_{[L^2(\Omega_1)]^3} \| \operatorname{curl} H \|_{[L^2(\Omega_1)]^3} \\ &\leq (2\mathbf{v}_0 \mu_u c_{\mathcal{H}} + \gamma) \| \operatorname{curl} H \|_{[L^2(\Omega_1)]^3}^2 + \frac{\mathbf{v}_0^2 \mu_u^2}{\gamma} \| H_0 \|_{[L^2(\Omega_1)]^3}^2. \end{aligned}$$

Further, we observe that

$$(61) \quad \int_{\Omega_1} (v \times \mu \widehat{H}) \cdot \operatorname{curl} H = - \int_{\Omega_1} (\operatorname{curl} H \times \mu \widehat{H}) \cdot v = - \int_{\Omega_1} (\operatorname{curl} \widehat{H} \times \mu \widehat{H}) \cdot v,$$

since $\operatorname{curl} H_0 = j_0 = 0$ in Ω_1 .

By the homogenization (57) and the coercivity result of Lemma C.3, (1) we have on the other hand that

$$\begin{aligned} &\int_{\Omega} \kappa(\widehat{\theta}) \nabla \widehat{\theta} \cdot \nabla \theta + \int_{\Sigma} G(\sigma |\widehat{\theta}|^3 \widehat{\theta}) \theta \\ &= \int_{\Omega} \kappa(\widehat{\theta}) |\nabla \theta|^2 + \int_{\Sigma} G(\sigma |\theta|^3 \theta) \theta - \int_{\Omega} \kappa(\widehat{\theta}) \nabla(\theta_0 \varphi_0) \cdot \nabla \theta \\ &\geq c \min\{\|\theta\|_{V_{\Gamma}^{2,5}(\Omega)}^2, \|\theta\|_{V_{\Gamma}^{2,5}(\Omega)}^5\} - \int_{\Omega} \kappa(\widehat{\theta}) \nabla(\theta_0 \varphi_0) \cdot \nabla \theta. \end{aligned}$$

By Young's inequality, this implies that

$$\begin{aligned} &\int_{\Omega} \kappa(\widehat{\theta}) \nabla \widehat{\theta} \cdot \nabla \theta + \int_{\Sigma} G(\sigma |\widehat{\theta}|^3 \widehat{\theta}) \theta \geq c \min\{\|\theta\|_{V_{\Gamma}^{2,5}(\Omega)}^2, \|\theta\|_{V_{\Gamma}^{2,5}(\Omega)}^5\} \\ &\quad - \gamma \|\nabla \theta\|_{L^2(\Omega)}^2 - c_{\gamma} \|\nabla \theta_0\|_{L^2(\Omega)}^2 \geq \bar{c} \|\theta\|_{V_{\Gamma}^{2,5}(\Omega)}^2 - C. \end{aligned}$$

If we additionally consider the facts

$$\begin{aligned} \left| \int_{\Omega_1} f(\widehat{\theta}) \cdot v \right| &\leq \varrho_1 |\vec{g}| M_t \|v\|_{[L^1(\Omega_1)]^3}, \\ \left| \int_{\Omega} [r(\widehat{\theta}) |\operatorname{curl} \widehat{H}|^2 + \eta(\widehat{\theta}) D(\widehat{v}, \widehat{v})]_{(\delta)} \theta \right| &\leq \frac{\|\theta\|_{L^1(\Omega_1)}}{\delta}, \end{aligned}$$

we easily verify by Young's inequality that

$$\langle A(\{v, H, \theta\}), \{v, H, \theta\} \rangle \geq \frac{\gamma_0}{2} \|\{v, H, \theta\}\|_V^2 - C,$$

with the number γ_0 given by (47). This proves the coercivity.

In order to prove that A is pseudomonotone, we consider an arbitrary sequence $\{v_k, H_k, \theta_k\} \subset V$ such that

$$(62) \quad v_k \rightharpoonup v \text{ in } D_0^{1,2}(\Omega_1), \quad H_k \rightharpoonup H \text{ in } \mathcal{H}_{\mu}^0(\widetilde{\Omega}), \quad \theta_k \rightharpoonup \theta \text{ in } V_{\Gamma}^{2,5}(\Omega),$$

and we assume that

$$(63) \quad \limsup_{k \rightarrow \infty} \langle A(\{v_k, H_k, \theta_k\}), \{v_k, H_k, \theta_k\} - \{v, H, \theta\} \rangle \leq 0.$$

By well-known compactness properties and Lemma A.1, we find a subsequence, that we do not relabel, such that

$$(64) \quad \begin{aligned} v_k &\longrightarrow v \text{ in } L^4(\Omega_1), & H_k &\longrightarrow H \text{ in } L^2(\tilde{\Omega}), \\ \theta_k &\longrightarrow \theta \text{ in } L^2(\Omega), & \theta_k &\longrightarrow \theta \text{ in } L^2(\Sigma). \end{aligned}$$

Observe that

$$\begin{aligned} \int_{\Sigma} G(\sigma|\hat{\theta}_k|^3\hat{\theta}_k)(\theta_k - \theta) &= \int_{\Sigma} G(\sigma|\theta_k|^3\theta_k)(\theta_k - \theta) = \int_{\Sigma} \sigma|\theta_k|^3\theta_k G(\theta_k - \theta) \\ &= \int_{\Sigma} \varepsilon\sigma|\theta_k|^3\theta_k(\theta_k - \theta) - \int_{\Sigma} \varepsilon\sigma|\theta_k|^3\theta_k\tilde{\mathbf{H}}(\theta_k - \theta), \end{aligned}$$

where the operator $\tilde{\mathbf{H}}$ is compact from $L^{5/4}(\Sigma)$ into itself, according to Lemma C.5, (1). Thus, passing to subsequences if necessary, we find that

$$(65) \quad \liminf_{k \rightarrow \infty} \int_{\Sigma} G(\sigma|\hat{\theta}_k|^3\hat{\theta}_k)(\theta_k - \theta) = \liminf_{k \rightarrow \infty} \int_{\Sigma} \varepsilon\sigma|\theta_k|^3\theta_k(\theta_k - \theta) \geq 0.$$

By (63) and (64) and (65), and using straightforward rearrangements of terms, we see immediately that

$$\limsup_{k \rightarrow \infty} \left(\int_{\Omega_1} D(v_k - v, v_k - v) + \int_{\tilde{\Omega}} |\operatorname{curl}(H_k - H)|^2 + \int_{\Omega} |\nabla(\theta_k - \theta)|^2 \right) \leq 0.$$

We thus find (not relabelled) subsequences with the properties

$$(66) \quad v_k \longrightarrow v \text{ in } D_0^{1,2}(\Omega_1), \quad H_k \longrightarrow H \text{ in } \mathcal{H}_{\mu}^0(\tilde{\Omega}).$$

By the Dominated Convergence Theorem, this implies for a subsequence and for all $1 \leq q < \infty$ that

$$[r(\hat{\theta}_k)|\operatorname{curl}\hat{H}_k|^2 + \eta(\hat{\theta}_k)D(v_k, v_k)\chi_{\Omega_1}]_{(\delta)} \rightarrow [r(\hat{\theta})|\operatorname{curl}\hat{H}|^2 + \eta(\hat{\theta})D(v, v)\chi_{\Omega_1}]_{(\delta)},$$

in $L^q(\Omega)$. We observe that by the compactness of the nonlocal operator $\tilde{\mathbf{H}}$ and (62), we have generally

$$\liminf_{k \rightarrow \infty} \int_{\Sigma} G(\sigma|\theta_k|^3\theta_k)(\theta_k - \xi) \geq \int_{\Sigma} G(\sigma|\theta|^3\theta)(\theta - \xi),$$

for all $\xi \in V_{\Gamma}^{2,5}(\Omega)$. By this property and (66), we can easily show that

$$\begin{aligned} \liminf_{k \rightarrow \infty} \langle A(\{v_k, H_k, \theta_k\}), \{v_k, H_k, \theta_k\} - \{\varphi, \psi, \xi\} \rangle \\ \geq \langle A(\{v, H, \theta\}), \{v, H, \theta\} - \{\varphi, \psi, \xi\} \rangle, \end{aligned}$$

for all $\{\varphi, \psi, \xi\} \in V$, proving the pseudomonotonicity of A . By the results of [12], Ch. 2, Th. 2.7., or of [21] Ch. 27.3, the equation $A(\{v, H, \theta\}) = 0$ has at least one solution in V .

We at last prove that (55) is valid. By the previous considerations, we have obtained in particular the relation

$$(67) \quad \begin{aligned} \int_{\Omega_1} \varrho_{1C_V} \hat{v} \cdot \nabla \hat{\theta} \xi + \int_{\Omega} \kappa(\hat{\theta}) \nabla \hat{\theta} \cdot \nabla \xi + \int_{\Sigma} G(\sigma |\hat{\theta}|^3 \hat{\theta}) \xi \\ = \int_{\Omega} [r(\hat{\theta}) |\operatorname{curl} \hat{H}|^2 + \eta(\hat{\theta}) D(\hat{v}, \hat{v}) \chi_{\Omega_1}]_{(\delta)} \xi, \end{aligned}$$

for all $\xi \in V_{\Gamma}^{2,5}(\Omega)$. We define $k_0 := \operatorname{ess\,inf}_{\Gamma} \theta_0$, and we test with the function $\xi = (\hat{\theta} - k_0)^-$ in the relation (67). We observe that

$$\begin{aligned} \int_{\Omega_1} \varrho_{1C_V} \hat{v} \cdot \nabla \hat{\theta} (\hat{\theta} - k_0)^- &= \int_{\Omega_1} \varrho_{1C_V} \hat{v} \cdot \frac{1}{2} \nabla (\hat{\theta} - k_0)^{-2} = 0 \\ \int_{\Sigma} G(\sigma |\hat{\theta}|^3 \hat{\theta}) (\hat{\theta} - k_0)^- &= \int_{\Sigma} G(\sigma |\hat{\theta}|^3 \hat{\theta}) [(\hat{\theta} - k_0)^- + k_0] \geq 0. \end{aligned}$$

Here, we used the fact that $G(1) = 0$ and the elementary properties of the operator G in enclosures (see Lemma C.2, (5)). In order to obtain the inequality, we applied Lemma C.4. We get $\int_{\Omega} \kappa(\hat{\theta}) |\nabla (\hat{\theta} - k_0)^-|^2 \leq 0$, and since $\hat{\theta} \geq k_0$ on Γ , it follows that $\hat{\theta} \geq k_0$ almost everywhere in Ω . We can replace the term $|\hat{\theta}|^3 \hat{\theta}$ by $\hat{\theta}^4$ in (67). We obtain (54). Writing from now on $\{v, H, \theta\}$ instead of $\{\hat{v}, \hat{H}, \hat{\theta}\}$, this finishes the proof of the proposition. \square

For sequences of approximate solutions according to Proposition 2.2, we introduce the notation

$$(68) \quad M_{\delta} := \frac{1}{\operatorname{meas}(\Sigma)} \int_{\Sigma} \theta_{\delta}^4.$$

Proposition 2.3. *For any sequence of approximations $\{v_\delta, H_\delta, \theta_\delta\}$ according to Proposition 2.2, the following uniform estimates are valid:*

(1) *For the MHD energy, we have the estimate*

$$\begin{aligned} & \|v_\delta\|_{D^{1,2}(\Omega_1)} + \|H_\delta\|_{\mathcal{H}_\mu(\tilde{\Omega})} \\ & \leq c(\|f(\theta_\delta)\|_{[L^2(\Omega_1)]^3} + \|j_0\|_{[L^2(\tilde{\Omega}_{c_0})]^3} + \|v_0\|_{D^{1,2}(\Omega_1)}). \end{aligned}$$

(2) *For the temperature, we find for all $1 \leq p < \frac{3}{2}$ the uniform bounds*

$$\|\theta_\delta\|_{W_F^{1,p}(\Omega)} + \|\theta_\delta^4 - M_\delta\|_{L^1(\Sigma)} \leq C_p(K_0, \|\nabla\theta_0\|_{L^2(\Omega)}, \|\theta_0\|_{L^\infty(\Omega)}),$$

where K_0 is the right-hand side of (1), and C_p is a continuous function.

Proof. For the sake of notational simplicity, we write throughout this proof v instead of v_δ etc.

(1): We test in (52) with the vector field $v - v_0$, and in (53) with $H - H_0$. Recalling (60) and (61), we obtain, after adding both relations, that

$$\begin{aligned} (69) \quad & \int_{\Omega_1} \eta(\theta) D(v, v) + \int_{\tilde{\Omega}} r(\theta) |\operatorname{curl} H|^2 = \int_{\Omega_1} \varrho_1 v_j v_{0,i} \frac{\partial v_i}{\partial x_j} + \int_{\Omega_1} \eta(\theta) D(v, v_0) \\ & + \int_{\Omega_1} f(\theta) \cdot (v - v_0) + \int_{\Omega_1} (v_0 \times \mu H) \cdot \operatorname{curl} H + \int_{\tilde{\Omega}} r(\theta) j_0 \cdot \operatorname{curl} H. \end{aligned}$$

We estimate the right-hand side of (69) by standard inequalities, and we obtain that

$$\begin{aligned} & [(1 - \gamma)\eta_L c_{\text{Korn}}^{-1} - \varrho_1 \mathbf{v}_0 L - \gamma_2] \int_{\Omega_1} |\nabla v|^2 + [(1 - \gamma)r_L - c_{\mathcal{H}} \mathbf{v}_0 \mu_u] \int_{\tilde{\Omega}} |\operatorname{curl} H|^2 \\ & \leq \frac{L^2}{4\gamma_2} \|f(\theta)\|_{[L^2(\Omega_1)]^3}^2 + \|f(\theta) \cdot v_0\|_{[L^1(\Omega_1)]^3} + \frac{1}{4\gamma} \int_{\tilde{\Omega}} r(\theta) |j_0|^2, \end{aligned}$$

where we can choose γ, γ_2 arbitrary small. The estimate (1) follows from the assumption (47).

(2): For a parameter $\gamma > 0$ to be fixed later, we introduce the continuous function

$$g_\gamma(t) := \operatorname{sign}(t) \left(1 - \frac{1}{(1 + |t|)^\gamma} \right) \quad \text{for } t \in \mathbb{R}.$$

In (54) we use the test function

$$\xi = \xi_\gamma := g_\gamma(\theta - \tilde{\theta}_0) = \operatorname{sign}(\theta - \tilde{\theta}_0) \left(1 - \frac{1}{(1 + |\theta - \tilde{\theta}_0|)^\gamma} \right).$$

Here, we have set $\tilde{\theta}_0 := \theta_0 \varphi_0$, with a smooth function φ_0 such that $\varphi_0 = 0$ on Σ and $\varphi_0 = 1$ on Γ . Note that ξ vanishes on the boundary Γ , that $0 \leq \xi \leq 1$ in Ω , and that

$$\nabla \xi = \gamma \frac{\nabla(\theta - \tilde{\theta}_0)}{(1 + |\theta - \tilde{\theta}_0|)^{1+\gamma}},$$

so that we are allowed to test the relation (54) with this function.

Denoting by Ψ the primitive function of g_γ that vanishes at zero, we observe that

$$\int_{\Omega_1} \varrho_1 c_V v \cdot \nabla(\theta - \tilde{\theta}_0) \xi = \int_{\Omega_1} \varrho_1 c_V v \cdot \nabla \Psi(\theta - \tilde{\theta}_0) = 0.$$

By Lemma C.4 and the fact that $\tilde{\theta}_0$ vanishes on Σ , we obtain on the other hand that

$$\int_{\Sigma} G(\sigma \theta^4) \xi = \int_{\Sigma} G(\sigma \theta^4) \left(1 - \frac{1}{(1 + \theta)^\gamma}\right) \geq 0.$$

Thus, the inequality

$$\begin{aligned} \gamma \int_{\Omega} \frac{\kappa(\theta) |\nabla(\theta - \tilde{\theta}_0)|^2}{(1 + |\theta - \tilde{\theta}_0|)^{1+\gamma}} &\leq \gamma \int_{\Omega} \kappa(\theta) \frac{|\nabla \theta_0| |\nabla(\theta - \tilde{\theta}_0)|}{(1 + |\theta - \tilde{\theta}_0|)^{1+\gamma}} + \int_{\Omega_1} \varrho_1 c_V |v \cdot \nabla \tilde{\theta}_0| \\ &\quad + \int_{\Omega} [r(\theta) |\operatorname{curl} H|^2 + \eta(\theta) D(v, v) \chi_{\Omega_1}](\delta), \end{aligned}$$

is readily verified. By Young's inequality, it follows that

$$\begin{aligned} \frac{\kappa_L \gamma}{2} \int_{\Omega} \frac{|\nabla(\theta - \tilde{\theta}_0)|^2}{(1 + |\theta - \tilde{\theta}_0|)^{1+\gamma}} &\leq \frac{\gamma \kappa_u}{2} \|\nabla \tilde{\theta}_0\|_{L^2(\Omega)}^2 + \varrho_1 c_V L \|\nabla \tilde{\theta}_0\|_{L^2(\Omega_1)} \|\nabla v\|_{[L^2(\Omega_1)]^9} \\ &\quad + \int_{\Omega} r(\theta) |\operatorname{curl} H|^2 + \int_{\Omega_1} \eta(\theta) D(v, v). \end{aligned}$$

Making use of (1), we obtain for arbitrary $\gamma \in]0, 1[$ that

$$\gamma \int_{\Omega} \frac{|\nabla(\theta - \tilde{\theta}_0)|^2}{(1 + |\theta - \tilde{\theta}_0|)^{1+\gamma}} \leq C_1,$$

where the constant C_1 depends on the data through the previous estimate (1). By the arguments of Lemma C.7, we obtain that

$$\|\theta - \tilde{\theta}_0\|_{W_{\Gamma}^{1,p}(\Omega)} \leq C_p (\|f(\theta)\|_{[L^2(\Omega_1)]^3}, \|j_0\|_{[L^2(\tilde{\Omega}_c)]^3}, \|v_0\|_{D^{1,2}(\Omega_1)}, \|\nabla \tilde{\theta}_0\|_{L^2(\Omega)}).$$

for all $1 \leq p < \frac{3}{2}$.

In order to derive the complete estimate (2), we now want to estimate θ on the boundary Σ . We define $\bar{k}_0 := \operatorname{ess\,sup}_{\Gamma} \theta_0$, and we recall the definition (68) of the numbers M_δ .

Observe that in the case of $M_\delta \leq \bar{k}_0^4$, the estimate

$$(70) \quad \|\theta^4 - M_\delta\|_{L^1(\Sigma)} \leq (\operatorname{meas}(\Sigma) + 1)M_\delta \leq 2\bar{k}_0^4 \operatorname{meas}(\Sigma),$$

is valid. Suppose now that $M_\delta > \bar{k}_0^4$. For $\gamma > 0$, we introduce the function

$$g_\gamma(t) := \frac{1}{\gamma} \operatorname{sign}(t) \min\{|t|, \gamma\} + 1, \quad \text{for } t \in \mathbb{R}.$$

In (54) we choose the test function

$$\xi = \xi_{\delta, \gamma} := g_\gamma(\theta - M_\delta) = \frac{1}{\gamma} \operatorname{sign}(\theta^4 - M_\delta) \min\{|\theta^4 - M_\delta|, \gamma\} + 1.$$

Note that for all $0 < \gamma < M_\delta - \bar{k}_0^4$, the function ξ vanishes on Γ , and observe that $0 \leq \xi \leq 2$ in Ω . On the other hand, since

$$\nabla \xi = \frac{4}{\gamma} |\theta|^3 \chi_{\{x \in \Omega: |\theta(x)^4 - M_\delta| < \gamma\}} \nabla \theta,$$

we can verify that

$$|\nabla \xi|^2 \leq \left(\frac{4}{\gamma}\right)^2 (M_\delta + \gamma)^{\frac{3}{2}} |\nabla \theta|^2 \in L^1(\Omega),$$

so that we can test with this function in (54). Since g_γ is nondecreasing, we have $\nabla \theta \cdot \nabla g_\gamma(\theta) = g'_\gamma(\theta) |\nabla \theta|^2 \geq 0$, and we obtain that

$$(71) \quad \int_{\Sigma} G(\sigma|\theta|^4) g_\gamma(\theta) \leq - \int_{\Omega_1} \varrho_1 c_V |v \cdot \nabla \tilde{\theta}_0| g_\gamma(\theta) \\ + \int_{\Omega} [r(\theta) |\operatorname{curl} H|^2 + \eta(\theta) D(v, v) \chi_{\Omega_1}(\delta)] g_\gamma(\theta).$$

Now, since Ω is an enclosure and $G(1) \equiv 0$ (see Lemma C.2), we can write

$$\int_{\Sigma} G(\sigma|\theta|^4) \left[\frac{1}{\gamma} \operatorname{sign}(\theta^4 - M_\delta) \min\{|\theta^4 - M_\delta|, \gamma\} + 1 \right] \\ = \int_{\Sigma} G(\sigma[|\theta|^4 - M_\delta]) \frac{1}{\gamma} \operatorname{sign}(\theta^4 - M_\delta) \min\{|\theta^4 - M_\delta|, \gamma\}.$$

Letting $\gamma \rightarrow 0$ in (71), it follows that

$$\begin{aligned} & \int_{\Sigma} G(\sigma[|\theta|^4 - M_{\delta}]) \operatorname{sign}(\theta^4 - M_{\delta}) \\ & \leq 2 \left(\int_{\Omega_1} \varrho_1 c_V |v \cdot \nabla \tilde{\theta}_0| + \int_{\Omega} [r(\theta) |\operatorname{curl} H|^2 + \eta(\theta) D(v, v) \chi_{\Omega_1}] \right). \end{aligned}$$

By the previous estimates and Lemma C.3, we get

$$(72) \quad \|\theta^4 - M_{\delta}\|_{L^1(\Sigma)} \leq c(\|f(\theta)\|_{[L^2(\Omega_1)]^3}^2 + \|j_0\|_{[L^2(\tilde{\Omega}_c)]^3}^2 + \|v_0\|_{D^{1,2}(\Omega_1)}^2 + \|\nabla \tilde{\theta}_0\|_{L^2(\Omega)}^2).$$

Putting together (70) and (72), we obtain for all $\delta > 0$ that

$$\begin{aligned} \|\theta^4 - M_{\delta}\|_{L^1(\Sigma)} & \leq c(\|f(\theta)\|_{[L^2(\Omega_1)]^3}^2 + \|j_0\|_{[L^2(\tilde{\Omega}_c)]^3}^2 \\ & \quad + \|v_0\|_{D^{1,2}(\Omega_1)}^2 + \|\nabla \tilde{\theta}_0\|_{L^2(\Omega)}^2) + 2\bar{k}_0^4 \operatorname{meas}(\Sigma), \end{aligned}$$

which finally proves (2). \square

Proposition 2.4. *Let $\{v_{\delta}, H_{\delta}, \theta_{\delta}\}$ be any sequence of approximate solutions according to Proposition 2.2. Then there exists some $\{v, H, \theta\} \in D^{1,2}(\Omega) \times \mathcal{H}_{\mu}(\tilde{\Omega}) \times V^{p,4}(\Omega)$ ($1 \leq p < 3/2$) and some subsequence $\delta \rightarrow 0$ such that*

$$\begin{aligned} v_{\delta} & \longrightarrow v \text{ in } D^{1,2}(\Omega_1), & H_{\delta} & \longrightarrow H \text{ in } \mathcal{H}_{\mu}(\tilde{\Omega}), \\ \theta_{\delta} & \rightharpoonup \theta \text{ in } W^{1,p}(\Omega), & \theta_{\delta}^4 & \longrightarrow \theta^4 \text{ in } L^1(\Sigma). \end{aligned}$$

Proof. By the estimates of Proposition 2.3, we first find a sequence

$$(73) \quad v_{\delta} \rightharpoonup v \text{ in } D^{1,2}(\Omega_1), \quad H_{\delta} \rightharpoonup H \text{ in } \mathcal{H}_{\mu}(\tilde{\Omega}), \quad \theta_{\delta} \rightharpoonup \theta \text{ in } W^{1,p}(\Omega).$$

By well-known compactness properties, we now find a (not relabelled) subsequence such that

$$(74) \quad \begin{aligned} v_{\delta} & \longrightarrow v \text{ in } L^4(\Omega_1), & H_{\delta} & \longrightarrow H \text{ in } L^2(\tilde{\Omega}), & \theta_{\delta} & \longrightarrow \theta \text{ in } L^p(\Omega), \\ \theta_{\delta} & \longrightarrow \theta \text{ in } L^p(\Sigma), & \theta_{\delta} & \longrightarrow \theta \text{ almost everywhere in } \Omega. \end{aligned}$$

Passing to the limit $\delta \rightarrow 0$ in (52), (53), by the same arguments as in the proof of Proposition 2.2, we see that the pair $\{v, H\}$ satisfies the relations

$$\begin{aligned} & \int_{\Omega_1} \varrho_1 (v \cdot \nabla) v \cdot \varphi + \int_{\Omega_1} \eta(\theta) D(v, \varphi) = \int_{\Omega_1} (\operatorname{curl} H \times \mu H) \cdot \varphi + \int_{\Omega_1} f(\theta) \cdot \varphi, \\ & \int_{\tilde{\Omega}} r(\theta) \operatorname{curl} H \cdot \operatorname{curl} \psi = \int_{\tilde{\Omega}} (v \times \mu H) \cdot \operatorname{curl} \psi. \end{aligned}$$

In these relations, we now use the test functions $\varphi = v_\delta - v, \psi = H_\delta - H$. We do the same in the identities (52) and (53). Subtracting the two arising integral relations, we verify easily, by (73) and (74), that the right-hand sides of both relations converge to zero for $\delta \rightarrow 0$, proving that

$$v_\delta \longrightarrow v \text{ in } D^{1,2}(\Omega_1), \quad H_\delta \longrightarrow H \text{ in } \mathcal{H}_\mu(\tilde{\Omega}).$$

Thus, we have also

$$D(v_\delta, v_\delta) \longrightarrow D(v, v) \text{ in } L^1(\Omega_1), \quad |\operatorname{curl} H_\delta|^2 \longrightarrow |\operatorname{curl} H|^2 \text{ in } L^1(\tilde{\Omega}),$$

which, in view of Lemma C.8, yields the strong convergence

$$(75) \quad [r(\theta_\delta)|\operatorname{curl} H_\delta|^2 + \eta(\theta_\delta)D(v_\delta, v_\delta)\chi_{\Omega_1}]_{(\delta)} \longrightarrow r(\theta)|\operatorname{curl} H|^2 + \eta(\theta)D(v, v)\chi_{\Omega_1},$$

in $L^1(\Omega)$. Now we prove the convergence property for the boundary integral. Since the employed techniques are similar to the ones used in [5], we will only give the main ideas.

First, we prove that the sequence of numbers M_δ given by (68) is bounded. Using the estimate (2) and Fatou's lemma, we can write that

$$(76) \quad \int_\Sigma \liminf_{\delta \rightarrow 0} |\theta_\delta^4 - M_\delta| \leq \liminf_{\delta \rightarrow 0} \int_\Sigma |\theta_\delta^4 - M_\delta| \leq C.$$

Seeking a contradiction, we suppose that there exists a subsequence such that $M_\delta \rightarrow \infty$. For this subsequence, we obtain almost everywhere on Σ that

$$\liminf_{\delta \rightarrow 0} |\theta_\delta^4 - M_\delta| = \lim_{\delta \rightarrow 0} |\theta_\delta^4 - M_\delta| = \lim_{\delta \rightarrow 0} |\theta^4 - M_\delta| = +\infty,$$

since the pointwise limit θ^4 is almost everywhere finite. This contradicts (76).

Thus, the sequence $\{M_\delta\}$ is bounded, which by definition also implies a uniform bound $\|\theta_\delta^4\|_{L^1(\Sigma)} \leq C$. By Lemma C.5, (3), it follows that

$$\tilde{\mathbf{H}}(\theta_\delta^4) \rightharpoonup u \text{ in } L^1(\Sigma),$$

for some $u \in L^1(\Sigma)$.

Now, for an arbitrary $\xi \in C_c^\infty(\Omega)$, we pass to the limit $\delta \rightarrow 0$ in the relation (54). Considering (75), we obtain that

$$(77) \quad \int_{\Omega_1} \varrho_1 c_V v \cdot \nabla \theta \xi + \int_\Omega \kappa(\theta) \nabla \theta \cdot \nabla \xi + \lim_{\delta \rightarrow 0} \int_\Sigma \varepsilon \sigma |\theta_\delta|^4 \xi - \int_\Sigma \varepsilon \sigma u \xi \\ = \int_\Omega r(\theta) |\operatorname{curl} H|^2 \xi + \int_{\Omega_1} \eta(\theta) D(v, v) \xi.$$

In order to compute $\lim_{\delta \rightarrow 0} \int_{\Sigma} G(\sigma|\theta_{\delta}|^4)\xi$, we now test in (54) with the function $g_{\gamma}(\theta_{\delta})\xi$, where ξ is an arbitrary $C_c^{\infty}(\Omega)$ -function which is nonnegative in Ω , and g_{γ} is for $\gamma > 0$ the nonincreasing function defined by $g_{\gamma}(t) := 1/(1 + \gamma t^4)$.

Using the techniques of the proof of [5], we can prove the inequality

$$(78) \quad \int_{\Omega_1} \varrho_1 c_V v_{\delta} \cdot \nabla \theta_{\delta} g_{\gamma}(\theta_{\delta}) \xi + \int_{\Omega} \kappa(\theta_{\delta}) \nabla \theta_{\delta} \cdot \nabla \xi g_{\gamma}(\theta_{\delta}) + \int_{\Sigma} G(\sigma|\theta_{\delta}|^4) \xi g_{\gamma}(\theta_{\delta}) \\ \geq \int_{\Omega} \left[r(\theta_{\delta}) |\operatorname{curl} H_{\delta}|^2 + \eta(\theta_{\delta}) D(v_{\delta}, v_{\delta}) \chi_{\Omega_1} \right]_{(\delta)} \xi g_{\gamma}(\theta_{\delta}),$$

in which it is, by the same arguments, possible to take the limit $\delta \rightarrow 0$ to obtain the relation

$$\int_{\Omega_1} \varrho_1 c_V v \cdot \nabla \theta g_{\gamma}(\theta) \xi + \int_{\Omega} \kappa(\theta) \nabla \theta \cdot \nabla \xi g_{\gamma}(\theta) + \int_{\Sigma} \varepsilon \sigma \frac{\theta^4}{1 + \gamma \theta^4} \xi - \int_{\Sigma} \varepsilon \sigma u \xi g_{\gamma}(\theta) \\ \geq \int_{\Omega} r(\theta) |\operatorname{curl} H|^2 \xi g_{\gamma}(\theta) + \int_{\Omega_1} \eta(\theta) D(v, v) \xi g_{\gamma}(\theta).$$

At this point, recalling that $g = g_{\gamma}$, we observe that for all $t \in \mathbb{R}^+$, the monotone convergence $g_{\gamma}(t) \nearrow 1$ as $\gamma \rightarrow 0$ takes place. Therefore, passing to the limit in the last inequality yields

$$(79) \quad \int_{\Omega_1} \varrho_1 c_V v \cdot \nabla \theta \xi + \int_{\Omega} \kappa(\theta) \nabla \theta \cdot \nabla \xi + \int_{\Sigma} \varepsilon \sigma |\theta|^4 \xi - \int_{\Sigma} \varepsilon \sigma u \xi \\ \geq \int_{\Omega} r(\theta) |\operatorname{curl} H|^2 \xi + \int_{\Omega_1} \eta(\theta) D(v, v) \xi.$$

Comparing the relations (77) and (79), we find that

$$\int_{\Sigma} \varepsilon \sigma |\theta|^4 \xi \geq \lim_{\delta \rightarrow 0} \int_{\Sigma} \varepsilon \sigma |\theta_{\delta}|^4 \xi,$$

for all $\xi \in C_c^{\infty}(\Omega)$ such that $\xi \geq 0$ in Ω . With the help of Fatou's lemma, we even have

$$(89) \quad \lim_{\delta \rightarrow 0} \int_{\Sigma} \varepsilon \sigma |\theta_{\delta}|^4 \xi = \int_{\Sigma} \varepsilon \sigma |\theta|^4 \xi.$$

But in view of (49), it is possible to choose $\xi \in C_c^{\infty}(\Omega)$ such that $\xi \geq 0$ in Ω and $\xi = 1$ on Σ . It then follows from (80) and Lemma C.9 that $\theta_{\delta}^4 \rightarrow \theta^4$ in $L^1(\Sigma)$, proving the last assertion and the proposition. \square

We are now able to prove the main result of this section.

P r o o f of Theorem 2.1. Thanks to the convergence properties stated by Proposition 2.4, we find a triple $\{v, H, \theta\} \in D^{1,2}(\Omega_1) \times \mathcal{H}_\mu(\tilde{\Omega}) \times V^{p,4}(\Omega)$, with $1 \leq p < \frac{3}{2}$ arbitrary, such that $v = v_0$ on $\partial\Omega_1$, $\theta = \theta_0$ on Γ , $\text{curl } H = j_0$ in $\tilde{\Omega}_{c_0}$, and the relations

$$\begin{aligned}
 (81) \quad & \int_{\Omega_1} \varrho_1 (v \cdot \nabla) v \cdot \varphi + \int_{\Omega_1} \eta(\theta) D(v, \varphi) = \int_{\Omega_1} (\text{curl } H \times \mu H) \cdot \varphi + \int_{\Omega_1} f(\theta) \cdot \varphi, \\
 & \int_{\tilde{\Omega}} r(\theta) \text{curl } H \cdot \text{curl } \psi = \int_{\Omega_1} (v \times \mu H) \cdot \text{curl } \psi, \int_{\tilde{\Omega}} r(\theta) j_0 \cdot \text{curl } \psi, \\
 & \int_{\Omega_1} \varrho_1 c_V v \cdot \nabla \theta \xi + \int_{\Omega} \kappa(\theta) \nabla \theta \cdot \nabla \xi + \int_{\Sigma} G(\sigma \theta^4) \xi \\
 & \quad = \int_{\Omega} r(\theta) |\text{curl } H|^2 \xi + \int_{\Omega_1} \eta(\theta) D(v, v) \xi,
 \end{aligned}$$

are satisfied for all $\{\varphi, \psi, \xi\} \in D_0^{1,2}(\Omega_1) \times \mathcal{H}_\mu^0(\tilde{\Omega}) \times V_T^{p',\infty}(\Omega)$. \square

2.2. Small coefficient of thermal expansion. In the first section, we replaced the Boussinesq approximation of the gravitational force (4) by the *bounded* term (50). We can argue in favor of this choice by observing that the Boussinesq approximation is valid only in the range of *small* density variations, that is,

$$(82) \quad 0 \leq \alpha(\theta - \theta_M) \ll 1.$$

This approach would be fully justified if we could prove *a posteriori* that the weak solutions obtained in the first section actually satisfy (82). We cannot give a proof of this full justification. Instead, we have a weaker result.

Lemma 2.5. *Assume that the hypotheses of Theorem 2.1 are satisfied, and assume in addition that θ_0 is a constant. Let the numbers α, M_t in (50) be such that*

$$1 - \bar{c} \frac{\text{meas}(\Omega_1) \varrho_1^2 |\bar{g}|^2}{\kappa_l} M_t \alpha > 0,$$

where $\bar{c} = \sqrt{2} c c_0^2$, with the constant c that appears in Proposition 2.3, (1) and the constant c_0 of the embedding $W^{1,2}(\Omega) \hookrightarrow L^6(\Omega)$.

Then, for any weak solution of (P) constructed as in Theorem 2.1, the estimate

$$\left(\frac{1}{\text{meas}(\Omega_1)} \int_{\Omega_1} \alpha^2 |\theta - \theta_M|^2 \right)^{1/2} \leq \frac{\bar{c} \alpha (\|j_0\|_{[L^2(\tilde{\Omega}_{c_0})]^3}^2 + \|v_0\|_{D^{1,2}(\Omega_1)}^2)}{\kappa_l - \bar{c} \text{meas}(\Omega_1) \varrho_1^2 |\bar{g}|^2 \alpha M_t},$$

is valid.

Proof. We consider some sequence of approximate solutions $\{v_\delta, H_\delta, \theta_\delta\}$ according to Proposition 2.2 and derive an additional uniform estimate. We start from (54), and we for a while write v, H, θ instead of $v_\delta, H_\delta, \theta_\delta$.

For a parameter $\lambda > 0$, we are allowed to use the test function

$$\xi = (\theta - \theta_0)^{(\lambda)} = \text{sign}(\theta - \theta_0) \min\{|\theta - \theta_0|, \lambda\}.$$

Denoting by Ψ a primitive of the function $s \mapsto (s - \theta_0)^{(\lambda)}$ ($s \in \mathbb{R}$), we can write

$$\int_{\Omega_1} \varrho_1 c_V v \cdot \nabla \theta \xi = \int_{\Omega_1} \varrho_1 c_V v \cdot \nabla \Psi(\theta) = 0,$$

since v is divergence free in Ω_1 and tangential on $\partial\Omega_1$. It follows that

$$(83) \quad \int_{\Omega} \kappa(\theta) |\nabla(\theta - \theta_0)^{(\lambda)}|^2 + \int_{\Sigma} G(\sigma\theta^4)(\theta - \theta_0)^{(\lambda)} \\ = \int_{\Omega} [\eta(\theta)D(v, v)\chi_{\Omega_1} + r(\theta)|\text{curl } H|^2]_{(\delta)} (\theta - \theta_0)^{(\lambda)}.$$

Using the selfadjointness of the operator G and the fact that $G(1) \equiv 0$ on Σ , we can write

$$\int_{\Sigma} G(\sigma\theta^4)(\theta - \theta_0)^{(\lambda)} = \int_{\Sigma} G(\sigma\theta^4)[(\theta - \theta_0)^{(\lambda)} + \min\{\theta_0, \lambda\}].$$

We see that the function

$$F(s) := [(s - \theta_0)^{(\lambda)} + \min\{\theta_0, \lambda\}] \quad \text{for } s \in \mathbb{R},$$

satisfies the assumptions of Lemma C.4 below. Therefore, (83) leads to the inequality

$$\int_{\Omega} \kappa(\theta) |\nabla(\theta - \theta_0)^{(\lambda)}|^2 \leq \int_{\Omega} \left[\eta(\theta)D(v, v)\chi_{\Omega_1} + r(\theta)|\text{curl } H|^2 \right]_{(\delta)} (\theta - \theta_0)^{(\lambda)}.$$

Using (1), we find that

$$(84) \quad \int_{\Omega} \kappa(\theta) |\nabla(\theta - \theta_0)^{(\lambda)}|^2 \leq \lambda \left(\int_{\Omega_1} \eta(\theta)D(v, v) + \int_{\Omega} r(\theta)|\text{curl } H|^2 \right) \\ \leq c(\|f(\theta)\|_{[L^2(\Omega_1)]^3}^2 + \|j_0\|_{[L^2(\tilde{\Omega}_{c_0})]^3}^2 + \|v_0\|_{D^{1,2}(\Omega_1)}^2)\lambda.$$

On the other hand, using the continuity of the embedding $W^{1,2}(\Omega) \hookrightarrow L^6(\Omega)$, we find that

$$\int_{\Omega} \kappa(\theta) |\nabla(\theta - \theta_0)^{(\lambda)}|^2 \geq c_0^{-2} \kappa_l \|(\theta - \theta_0)^{(\lambda)}\|_{L^6(\Omega)}^2.$$

This together with (84) obviously gives that

$$\begin{aligned} c_0^{-2} \kappa_l \lambda^2 \text{meas}(\{x \in \Omega: |\theta - \theta_0| \geq \lambda\})^{1/3} \\ \leq c(\|f(\theta)\|_{[L^2(\Omega_1)]^3}^2 + \|j_0\|_{[L^2(\tilde{\Omega}_{c_0})]^3}^2 + \|v_0\|_{D^{1,2}(\Omega_1)}^2) \lambda. \end{aligned}$$

Therefore,

$$\begin{aligned} \sup_{\lambda > 0} \{\lambda \text{meas}(\{x \in \Omega_1: |\theta - \theta_0| \geq \lambda\})^{1/3}\} \\ \leq \frac{cc_0^2}{\kappa_l} (\|f(\theta_\delta)\|_{[L^2(\Omega_1)]^3}^2 + \|j_0\|_{[L^2(\tilde{\Omega}_{c_0})]^3}^2 + \|v_0\|_{D^{1,2}(\Omega_1)}^2). \end{aligned}$$

Now, we apply the embedding properties of the weak L^p -spaces (see Lemma C.6) in order to obtain that

$$\begin{aligned} (85) \quad \|\theta - \theta_0\|_{L^2(\Omega_1)} &\leq \sqrt{2} \text{meas}(\Omega_1)^{1/2} \sup_{\lambda > 0} \{\lambda \text{meas}(\{x \in \Omega_1: |\theta - \theta_0| \geq \lambda\})^{1/3}\} \\ &\leq \frac{\bar{c} \text{meas}(\Omega_1)^{1/2}}{\kappa_l} (\|f(\theta)\|_{[L^2(\Omega_1)]^3}^2 + \|j_0\|_{[L^2(\tilde{\Omega}_{c_0})]^3}^2 + \|v_0\|_{D^{1,2}(\Omega_1)}^2). \end{aligned}$$

On the other hand, we use the estimate (51), and can write

$$\begin{aligned} (86) \quad \|f(\theta)\|_{[L^2(\Omega_1)]^3}^2 &\leq \varrho_1^2 |\bar{g}|^2 M_t \int_{\Omega_1} \alpha |\theta - \theta_M| \\ &\leq \varrho_1^2 |\bar{g}|^2 M_t \alpha \text{meas}(\Omega_1)^{1/2} \|\theta - \theta_M\|_{L^2(\Omega_1)}. \end{aligned}$$

In view of (85), we then have

$$\begin{aligned} \left(1 - \frac{\bar{c} \text{meas}(\Omega_1) \varrho_1^2 |\bar{g}|^2}{\kappa_l} M_t \alpha\right) \|\theta - \theta_M\|_{L^2(\Omega_1)} \\ \leq \frac{\bar{c} \text{meas}(\Omega_1)^{1/2} (\|j_0\|_{[L^2(\tilde{\Omega}_{c_0})]^3}^2 + \|v_0\|_{D^{1,2}(\Omega_1)}^2)}{\kappa_l}. \end{aligned}$$

We recall that $\theta = \theta_\delta$. The claim follows, since the last estimate is preserved in the limit $\delta \rightarrow 0$. \square

Remark 2.6. Note that at the expense of technical complications, a slightly modified result holds if θ_0 is not a constant. Lemma 2.5 shows that the density variations in the fluid are controlled by the data in a weaker norm than the L^∞ -Norm. That is the reason why replacing (4) by (50) as in the first section is only partially justified. However, the proof of Lemma 2.5 shows a very simple way to deal with the linear growth condition (12) by means of a smallness assumption and a fixed-point procedure, as we will show in the remainder of this section.

Assuming that the hypotheses of Theorem 2.1 are satisfied, we prove the following result.

Theorem 2.7. *Let the assumptions of Theorem 2.1 be satisfied, but let f be given by (12). If the coefficient α is sufficiently small with respect to the other data, the existence result of Theorem 2.1 holds true.*

The remainder of the section is devoted to the proof of this theorem. In the next statements 2.8 and 2.9, we construct approximate solutions with a fixed-point principle. We use again the notation of the proof of Proposition 2.2, and we additionally introduce

$$J_n(\Omega_1) := \{u \in [L^2(\Omega_1)]^3 \mid \operatorname{div} u = 0 \text{ in } \Omega_1, u \cdot \vec{n} = 0 \text{ on } \partial\Omega_1\},$$

where the constraints are meant in the sense of the generalized div operator.

Proposition 2.8. *Let $\delta > 0$ be an arbitrary number. Suppose that the assumptions of Theorem 2.7 are satisfied. If $\{\tilde{v}, \tilde{H}, \tilde{\theta}\}$ is an arbitrary element of $J_n(\Omega_1) \times [L^2(\tilde{\Omega})]^3 \times L^2(\Omega)$, then there exists a unique triple*

$$\{v, H, \theta\} \in D^{1,2}(\Omega_1) \times \mathcal{H}_\mu(\tilde{\Omega}) \times V^{2,5}(\Omega),$$

such that $v = v_0$ on $\partial\Omega_1$, $\theta = \theta_0$ on Γ , $\operatorname{curl} H = j_0$ in $\tilde{\Omega}_{c_0}$, and

$$(87) \quad \int_{\Omega_1} \varrho_1(\tilde{v} \cdot \nabla)v \cdot \varphi + \int_{\Omega_1} \eta(\tilde{\theta})D(v, \varphi) = \int_{\Omega_1} (\operatorname{curl} H \times [\mu\tilde{H}]_{(\delta)}) \cdot \varphi + \int_{\Omega_1} f(\tilde{\theta}) \cdot \varphi,$$

$$(88) \quad \int_{\tilde{\Omega}} r(\tilde{\theta}) \operatorname{curl} H \cdot \operatorname{curl} \psi = \int_{\Omega_1} (v \times [\mu\tilde{H}]_{(\delta)}) \cdot \operatorname{curl} \psi,$$

$$(89) \quad \int_{\Omega_1} \varrho_1 c_V \tilde{v} \cdot \nabla \theta \xi + \int_{\Omega} \kappa(\tilde{\theta}) \nabla \theta \cdot \nabla \xi + \int_{\Sigma} G(\sigma \theta^4) \xi \\ = \int_{\Omega} [r(\tilde{\theta}) |\operatorname{curl} H|^2 + \eta(\tilde{\theta}) D(v, v) \chi_{\Omega_1}]_{(\delta)} \xi,$$

are satisfied for all $\{\varphi, \psi, \xi\} \in D_0^{1,2}(\Omega_1) \times \mathcal{H}_\mu^0(\tilde{\Omega}) \times V_\Gamma^{2,5}(\Omega)$. In addition, $\theta \geq \operatorname{ess\,inf}_\Gamma \theta_0$ almost everywhere in Ω .

P r o o f. Existence is a routine matter and is proved, for example, by the method of Proposition 2.2.

We prove the uniqueness. Suppose that both $\{v_1, H_1, \theta_1\}$ and $\{v_2, H_2, \theta_2\}$ satisfy the integral relations (87), (88) and (89). Then, in (87) written alternatively for v_1 and v_2 , we test with $v_1 - v_2$ and subtract both results. We do the same in (88). We observe that

$$\int_{\Omega_1} \varrho_1(\tilde{v} \cdot \nabla(v_1 - v_2)) \cdot (v_1 - v_2) = 0.$$

We obtain the two relations

$$\begin{aligned} \int_{\Omega_1} \eta(\tilde{\theta}) D(v_1 - v_2, v_1 - v_2) &= \int_{\Omega_1} (\operatorname{curl}(H_1 - H_2) \times [\mu \tilde{H}]_{(\delta)}) \cdot (v_1 - v_2), \\ \int_{\tilde{\Omega}} r(\tilde{\theta}) |\operatorname{curl}(H_1 - H_2)|^2 &= \int_{\Omega_1} ((v_1 - v_2) \times [\mu \tilde{H}]_{(\delta)}) \cdot \operatorname{curl}(H_1 - H_2), \end{aligned}$$

which clearly imply, after addition, that $v_1 = v_2$ and $H_1 = H_2$. Now, for $\gamma > 0$, we use in (89) the test function $g_\gamma := \min\{(\theta_1 - \theta_2)^+, \gamma\}$, and observing that $\int_{\Omega_1} \varrho_1 c_V \tilde{v} \cdot \nabla(\theta_1 - \theta_2) g_\gamma = 0$, we obtain the relation

$$\int_{\Omega} \kappa(\tilde{\theta}) \nabla(\theta_1 - \theta_2) \cdot \nabla g_\gamma + \int_{\Sigma} G(\sigma[\theta_1^4 - \theta_2^4]) g_\gamma = 0.$$

By the arguments of [14], this leads to the uniqueness. \square

Proposition 2.8 provides us with a well-defined, obviously compact mapping

$$(90) \quad \begin{aligned} T_\delta: J_n(\Omega_1) \times [L^2(\tilde{\Omega})]^3 \times L^2(\Omega) &\longrightarrow J_n(\Omega_1) \times [L^2(\tilde{\Omega})]^3 \times L^2(\Omega) \\ \{\tilde{v}, \tilde{H}, \tilde{\theta}\} &\longmapsto \{v, H, \theta\}. \end{aligned}$$

Lemma 2.9. *If the coefficient α is sufficiently small with respect to the other data, the mapping T_δ given by (90) satisfies the assumptions of the Schauder fixed point principle. (In the simplified case of constant coefficients and boundary data, the smallness assumption on α is formulated more precisely in the equation (94) below.)*

Proof. To prove the continuity of T_δ is, again, a routine matter. We have to consider an arbitrary sequence $\{\tilde{v}_k, \tilde{H}_k, \tilde{\theta}_k\}$ in $J_n(\Omega_1) \times [L^2(\tilde{\Omega})]^3 \times L^2(\Omega)$ such that

$$\{\tilde{v}_k, \tilde{H}_k, \tilde{\theta}_k\} \longrightarrow \{\tilde{v}, \tilde{H}, \tilde{\theta}\} \text{ in } J_n(\Omega_1) \times [L^2(\tilde{\Omega})]^3 \times L^2(\Omega).$$

Choosing an arbitrary subsequence, that we not relabel, we will find by the compactness properties of T_δ a sub-subsequence such that $T_\delta(\{\tilde{v}_k, \tilde{H}_k, \tilde{\theta}_k\}) \longrightarrow w$ in $J_n(\Omega_1) \times [L^2(\tilde{\Omega})]^3 \times L^2(\Omega)$. By arguments similar to the proof of Proposition 2.2, that we do not want to repeat in detail, and the uniqueness obtained in Proposition 2.8, we show that $w = T_\delta(\{\tilde{v}, \tilde{H}, \tilde{\theta}\})$. Then, strong convergence follows for the entire sequence.

We finally prove that T_δ maps some closed, bounded convex set into itself. In order to more easily arrive at an estimate, we prove the claim in the simplified case that $v_0 = 0$, that θ_0 is constant and, all coefficients are piecewise constants. At the expense of technical complications, one verifies that the result is qualitatively

preserved in the general case. Inserting v in (87) and H in (88), we obtain the estimate (cp. (1))

$$(91) \quad \int_{\Omega_1} \eta D(v, v) + \int_{\tilde{\Omega}} r |\operatorname{curl} H|^2 \leq \frac{L^2}{\eta} \|f(\tilde{\theta})\|_{[L^2(\Omega_1)]^3}^2 + \int_{\tilde{\Omega}} r |j_0|^2.$$

Arguing now as in the proof of Lemma 2.5, we verify that the solution $T_\delta\{\tilde{v}, \tilde{H}, \tilde{\theta}\}$ satisfies

$$(92) \quad \|\theta - \theta_0\|_{L^2(\Omega_1)} \leq \frac{\bar{c} \operatorname{meas}(\Omega_1)^{1/2}}{\kappa_l} (\|f(\tilde{\theta})\|_{[L^2(\Omega_1)]^3}^2 + \|j_0\|_{[L^2(\tilde{\Omega}_{c_0})]^3}^2 + \|v_0\|_{D^{1,2}(\Omega_1)}^2).$$

To estimate $\|f(\tilde{\theta})\|_{[L^2(\Omega_1)]^3}$ as in (86) is not possible anymore. Instead, we simply assume that $\tilde{\theta} - \tilde{\theta}_M \in \overline{B_X(0)}(\subset L^2(\Omega_1))$ for some $X > 0$, and we obtain that

$$(93) \quad \|\theta - \theta_M\|_{L^2(\Omega_1)} \leq \frac{\bar{c} \operatorname{meas}(\Omega_1)^{1/2}}{\kappa_l} (\varrho_1^2 |\bar{g}|^2 \alpha^2 X^2 + \|j_0\|_{[L^2(\tilde{\Omega}_{c_0})]^3}^2 + \|v_0\|_{D^{1,2}(\Omega_1)}^2).$$

We introduce

$$\begin{aligned} a_1 &:= \frac{\bar{c} \operatorname{meas}(\Omega_1)^{1/2}}{\kappa_l} \varrho_1^2 |\bar{g}|^2 \alpha^2, \\ a_0 &:= \frac{\bar{c} \operatorname{meas}(\Omega_1)^{1/2}}{\kappa_l} (\|j_0\|_{[L^2(\tilde{\Omega}_{c_0})]^3}^2 + \|v_0\|_{D^{1,2}(\Omega_1)}^2). \end{aligned}$$

Under the condition

$$(94) \quad 1 - 4 \frac{\bar{c}^2 \operatorname{meas}(\Omega_1)}{\kappa_l^2} \varrho_1^2 |\bar{g}|^2 \alpha^2 (\|j_0\|_{[L^2(\tilde{\Omega}_{c_0})]^3}^2 + \|v_0\|_{D^{1,2}(\Omega_1)}^2) > 0,$$

we see that the equation $X = a_1 X^2 + a_0$ has the positive solution

$$(95) \quad X = \frac{2a_0}{1 + \sqrt{1 - 4a_0 a_1}} \leq 2 \frac{\bar{c} \operatorname{meas}(\Omega_1)^{1/2}}{\kappa_l} (\|j_0\|_{[L^2(\tilde{\Omega}_{c_0})]^3}^2 + \|v_0\|_{D^{1,2}(\Omega_1)}^2).$$

We then define a closed convex set $M = M(X) \subset L^2(\Omega)$ by

$$M := \{\tilde{\theta} \in L^2(\Omega) \mid \tilde{\theta} - \tilde{\theta}_M \in \overline{B_X(0)}(\subset L^2(\Omega_1))\}.$$

Note in view of (93) that $\tilde{\theta} \in M$ implies $\theta \in M$. In view of (91) and of the uniform estimates available for θ , we then easily find numbers Y_1, Y_2, Y_3 depending on X and on the data such that T_δ maps the closed, convex and bounded set

$$\overline{B_{Y_1}(0)} \times \overline{B_{Y_2}(0)} \times \overline{M \cap B_{Y_3}(\theta_0)} \subset J_n(\Omega_1) \times [L^2(\tilde{\Omega})]^3 \times L^2(\Omega),$$

into itself. □

Now, we prove the main result of this section.

P r o o f of Theorem 2.7. By Proposition 2.8 and Lemma 2.9, the Schauder fixed point theorem gives the existence of a triple $\{v_\delta, H_\delta, \theta_\delta\} \in D^{1,2}(\Omega_1) \times \mathcal{H}_\mu(\tilde{\Omega}) \times V^{2,5}(\Omega)$ such that $v = v_0$ on $\partial\Omega_1$, $\theta = \theta_0$ on Γ , $\text{curl}H = j_0$ in $\tilde{\Omega}_{c_0}$, and

$$\begin{aligned} \int_{\Omega_1} \varrho_1(v_\delta \cdot \nabla)v_\delta \cdot \varphi + \int_{\Omega_1} \eta(\theta_\delta)D(v_\delta, \varphi) &= \int_{\Omega_1} \{(\text{curl}H_\delta \times [\mu H_\delta]_{(\delta)}) + f(\theta_\delta)\} \cdot \varphi, \\ \int_{\tilde{\Omega}} r(\theta_\delta) \text{curl}H_\delta \cdot \text{curl}\psi &= \int_{\Omega_1} (v_\delta \times [\mu H_\delta]_{(\delta)}) \cdot \text{curl}\psi, \\ \int_{\Omega_1} \varrho_1 c_V v_\delta \cdot \nabla\theta_\delta \xi + \int_{\Omega} \kappa(\theta_\delta) \nabla\theta_\delta \cdot \nabla\xi + \int_{\Sigma} G(\sigma|\theta_\delta|^4)\xi \\ &= \int_{\Omega} [r(\theta_\delta)|\text{curl}H_\delta|^2 + \eta(\theta_\delta)D(v_\delta, v_\delta)\chi_{\Omega_1}]_{(\delta)}\xi. \end{aligned}$$

We pass to the limit with the same strategy as in the first section. In order to obtain the strong convergence

$$v_\delta \longrightarrow v \text{ in } D^{1,2}(\Omega_1), \quad H_\delta \longrightarrow H \text{ in } \mathcal{H}_\mu(\tilde{\Omega}),$$

the form $f(\theta_\delta) = -\varrho_1 \bar{g}\alpha(\theta_\delta - \theta_{M,\delta})$ means no particular difficulty. In the limit, we prove the existence of a weak solution. In addition, we can control the L^2 -norm of the density fluctuations by a continuous function of the data. In the simplified case that $v_0 = 0$ and that θ_0 is constant, we obtain in view of (95) that

$$(96) \quad \left(\frac{1}{\text{meas}(\Omega_1)} \int_{\Omega_1} \alpha^2 |\theta - \theta_M|^2 \right)^{1/2} \leq \frac{2\bar{c}\alpha}{\kappa_l} (\|j_0\|_{[L^2(\tilde{\Omega}_{c_0})]^3}^2 + \|v_0\|_{D^{1,2}(\Omega_1)}^2).$$

□

A. TOOLS FOR THE MAXWELL EQUATIONS

Lemma A.1. *Let the assumption (25) be satisfied for the function μ and let $\tilde{\Omega} \subset \mathbb{R}^3$ be a simply connected Lipschitz domain. Then, the following results hold true:*

- (1) *The embedding $\mathcal{H}_\mu(\tilde{\Omega}) \hookrightarrow [L^2(\tilde{\Omega})]^3$ is compact.*
- (2) *There exists a constant $C > 0$ such that, for all $\psi \in \mathcal{H}_\mu(\tilde{\Omega})$, $\int_{\tilde{\Omega}} |\text{curl}\psi|^2 \geq C \|\psi\|_{[L^2(\tilde{\Omega})]^3}^2$.*
- (3) *If the domain $\tilde{\Omega}$ is the domain described in the first paragraph, and satisfies (30), then there exist a number $\tilde{\xi} > 3$ such that $\mathcal{H}_\mu(\tilde{\Omega}) \hookrightarrow [L^{\tilde{\xi}}(\tilde{\Omega})]^3$ with continuous embedding.*

- (4) There exist $\tilde{\xi} > 3$ and a constant $C = C(\tilde{\Omega}, \tilde{\xi})$ such that if $C(1 - \mu_l/\mu_u) < 1$ is satisfied, then $\mathcal{H}_\mu(\tilde{\Omega}) \hookrightarrow [L^{\tilde{\xi}}(\tilde{\Omega})]^3$ continuously, without further assumptions on the pair $(\mu, \tilde{\Omega})$.
- (5) Every vector field $j_0 \in [L^2(\tilde{\Omega})]^3$ such that

$$\operatorname{div} j_0 = 0 \text{ in the generalized sense in } \tilde{\Omega}, \quad j_0 = 0 \text{ a.e. in } \tilde{\Omega}_{nc},$$

is uniquely representable as $\operatorname{curl} \psi$ with some $\psi \in \mathcal{H}_\mu(\tilde{\Omega})$.

Proof. See [4] Lemma 2.4, Lemma 2.7 and Lemma 4.2, and the references therein. \square

B. TOOLS FOR THE NAVIER-STOKES EQUATIONS

Lemma B.1. Let $\tilde{\Omega} \subset \mathbb{R}^3$ be a bounded domain with $\partial\tilde{\Omega} \in C^{0,1}$. Let $1 < q < \infty$ be arbitrary. Then it holds that:

1. Let $F \in [W_0^{1,q}(\tilde{\Omega})]^*$ satisfy $F(v) = 0$ for all $v \in D_0^{1,q}(\tilde{\Omega})$. Then there exists a unique $p \in L_M^q(\tilde{\Omega})$ such that F has the representation $F(v) = \int_{\tilde{\Omega}} p \operatorname{div} v$ for all $v \in [W_0^{1,q}(\tilde{\Omega})]^3$. Here, the subscript M denotes the subspace of functions having vanishing mean-value over $\tilde{\Omega}$.
2. For all $f \in L_M^q(\tilde{\Omega})$, the problem $\operatorname{div} v = f$ in $\tilde{\Omega}$ has at least one solution in the space $[W_0^{1,q}(\tilde{\Omega})]^3$, and there exists a constant $c > 0$, that depends only on $q, \tilde{\Omega}$, such that $\|v\|_{[W_0^{1,q}(\tilde{\Omega})]^3} \leq c \|f\|_{L^q(\tilde{\Omega})}$.

Proof. See [6], III. 3. \square

C. TOOLS FOR THE ENERGY EQUATION

We recall some basics about the nonlocal radiation operators K, G . For Banach spaces X, Y , we denote by $\mathcal{L}(X, Y)$ the set of all linear bounded operators from X into Y . We write $\mathcal{K}(X, Y)$ for the subspace of the compact operators of $\mathcal{L}(X, Y)$. In the following, $\Sigma = \partial\Omega_0$ with a connected open set Ω_0 , enclosed in the sense of the assumption (1). The following Lemma has been proved in [9] for polyhedral surfaces, in [19] for piecewise \mathcal{C}^1 -boundaries.

Lemma C.1. Let $\Sigma \in \mathcal{C}^1$ piecewise. Let $w: \Sigma \times \Sigma \rightarrow \mathbb{R}$ denote the view-factor (21). Then, for almost all $z \in \Sigma$,

$$\int_{\Sigma} w(z, y) \, dS_y \leq 1.$$

In addition, the equality is valid if and only if the enclosure condition (1) is satisfied.

The following lemma states easily derived, but essential consequences of Lemma C.1.

Lemma C.2. Let the hypotheses of Lemma C.1 be valid.

- (1) For each $1 \leq p \leq \infty$ the operator K extends to a bounded linear operator from $L^p(\Sigma)$ into itself, and the norm estimate $\|K\|_{\mathcal{L}(L^p(\Sigma), L^p(\Sigma))} \leq 1$ is valid.
- (2) The operator K is positive, in the sense that $K(f) \geq 0$ almost everywhere on Σ , whenever $f \geq 0$ almost everywhere on Σ . Moreover, K is positive semi-definite and selfadjoint in $L^2(\Sigma)$.
- (3) If $\varepsilon: \Sigma \rightarrow \mathbb{R}$ is such that

$$0 < \varepsilon_l \leq \varepsilon(z) \leq 1 \quad \text{on } \Sigma,$$

then the operator $[I - (1 - \varepsilon)K]^{-1}$ has an inverse in $\mathcal{L}(L^p(\Sigma), L^p(\Sigma))$.

- (4) The operator G is positive semi-definite and selfadjoint in $L^2(\Sigma)$. The operator $\mathbf{H} := I - G$ is positive, selfadjoint in $L^2(\Sigma)$, and satisfies for all $1 \leq p \leq \infty$ the norm estimate $\|\mathbf{H}\|_{\mathcal{L}(L^p(\Sigma), L^p(\Sigma))} \leq 1$.
- (5) Then, the kernel of the operator G consists of the functions constant almost everywhere on Σ .

Lemma C.3. Let $\Sigma \in \mathcal{C}^{1,\delta}$ for some $\delta > 0$.

- (1) There exists a positive constant \tilde{c} such that for all $\psi \in V_{\Gamma}^{2,5}(\Omega)$,

$$\int_{\Omega} |\nabla \psi|^2 + \int_{\Sigma} G(|\psi|^3 \psi) \geq \tilde{c} \min\{\|\psi\|_{V_{\Gamma}^{2,5}(\Omega)}^2, \|\psi\|_{V_{\Gamma}^{2,5}(\Omega)}^5\}.$$

- (2) If $\varepsilon < 1$ on Σ , there exists a positive constant c such that for all $\psi \in L^1(\Sigma)$ with the property $\int_{\Sigma} \psi \, dS = 0$, $\int_{\Sigma} G(\psi) \text{sign}(\psi) \geq c \|\psi\|_{L^1(\Sigma)}$.

Proof. For the proof of the point (1), see [14]. The proof of point (2) in [5] is correct if ε does not take the value one. \square

We also have the following result.

Lemma C.4. Let $F: \mathbb{R} \rightarrow \mathbb{R}$ be a nondecreasing, continuous function with $F(0) = 0$ and $|F(t)| \leq C_0(1 + |t|^s)$ as $|t| \rightarrow \infty$ ($0 \leq s < \infty$). Let $0 \leq r < \infty$ be an arbitrary number. Then for all $\psi \in L^{r+s}(\Sigma)$, $\int_{\Sigma} G(|\psi|^{r-1}\psi)F(\psi) \geq 0$.

Proof. See [5]. □

Lemma C.5. Let $\Sigma \in \mathcal{C}^{1,\delta}$ for some $\delta > 0$. Then the operator G has the representation $G = \varepsilon(I - \tilde{\mathbf{H}})$.

- (1) For $1 < p < \infty$, the operator $\tilde{\mathbf{H}}$ belongs to $\mathcal{K}(L^p(\Sigma), L^p(\Sigma))$.
- (2) If $p > 1/\delta$, then $\tilde{\mathbf{H}}$ belongs to $\mathcal{K}(L^p(\Sigma), C(\Sigma))$.
- (3) The operator $\tilde{\mathbf{H}}$ has the following weak compactness property. If the sequence $\{\psi_k\}$ is bounded in the space $L^1(\Sigma)$, then we can find a subsequence $\{k_j\}$ and some $u \in L^1(\Sigma)$ such that $\tilde{\mathbf{H}}(\psi_{k_j}) \rightharpoonup u$ in $L^1(\Sigma)$.

Proof. See [5]. □

Lemma C.6. Let (X, \mathcal{A}, μ) be a measurable space such that $\mu(X) < \infty$. For a measurable function $u: X \rightarrow \mathbb{R}$ and $1 < p < \infty$, define

$$[u]_{L_w^p(\Omega)} := \sup_{t>0} \{t\mu(\{x \in X: |u(x)| > t\})^{1/p}\}.$$

Then for all $1 < p < \infty$ and all $0 < \varepsilon < p - 1$, one has the inequality

$$\|u\|_{L^{p-\varepsilon}(X, \mathcal{A}, \mu)} \leq \left(\frac{p}{\varepsilon}\right)^{1/(p-\varepsilon)} (\mu(X))^{\varepsilon/p(p-\varepsilon)} [u]_{L_w^p}.$$

Proof. See [10], Paragraph 2.18. □

The following Lemma is useful for obtaining estimates in the L^1 -norm.

Lemma C.7. For a $p < 2$, let $\theta \in W_{\Gamma}^{1,p}(\Omega)$. Assume that there exists a constant $C_1 > 0$ such that for all $\delta \in]0, 1[$ one has $\int_{\Omega} |\nabla\theta|^2 / (1 + \theta)^{1+\delta} \leq C_1/\delta$. Then the estimate

$$(97) \quad \int_{\Omega} |\nabla\theta|^p \leq 2\text{meas}(\Omega)^{(2-p)/2} c_p C_1^{p/2} + \tilde{c}_p c_0^{6-3p} C_1^{3-p},$$

is valid, where the constants c_p, \tilde{c}_p depend only on p and c_0 is the embedding constant of $W_{\Gamma}^{1,p}(\Omega) \hookrightarrow L^{p^*}(\Omega)$ ($p^* =$ Sobolev embedding exponent).

Proof. We can follow the lines of [18], [17]. □

The next two Lemmas help us to shorten our proofs. We recall the notation (45).

Lemma C.8. *If $g_\delta \rightarrow g$ in $L^1(\tilde{\Omega})$, then also $[g_\delta]_{(\delta)} \rightarrow g$ in $L^1(\tilde{\Omega})$ as $\delta \rightarrow 0$.*

Proof. We have $|[g_\delta]_{(\delta)} - g| \leq |(g_\delta - g)/(1 + \delta g_\delta)| + \delta |g_\delta| |g| / (1 + \delta g_\delta)$ so that the assertion directly follows by dominated convergence. \square

Lemma C.9. *Let $u_k, u \in L^1(\Omega)$ be such that $u_k \rightarrow u$ almost everywhere and such that $\|u_k\|_{L^1(\Omega)} \rightarrow \|u\|_{L^1(\Omega)}$. Then $u_k \rightarrow u$ strongly in $L^1(\Omega)$.*

Proof. See [8], I.2.3 Proposition 4. \square

References

- [1] *A. Bossavit*: Electromagnétisme en vue de la modélisation. Springer, Berlin, Heidelberg, New York, 2004.
- [2] *S. Chandrasekhar*: Hydrodynamic and hydromagnetic stability. Dover Publications Inc., New York, 1981.
- [3] *G. Duvaut and J.-L. Lions*: Inéquations en thermoélasticité et magnétohydrodynamique. Archs ration. Mech. Analysis 46 (1972), 241–279.
- [4] *P.-E. Druet*: Higher integrability of the lorentz force for weak solutions to Maxwell's equations in complex geometries. Preprint 1270 of the Weierstrass Institute for Applied mathematics and Stochastics, Berlin, 2007. Available in pdf-format at <http://www.wias-berlin.de/publications/preprints/1270>.
- [5] *P.-E. Druet*: Weak solutions to a stationary heat equation with nonlocal radiation boundary condition and right-hand side in L^p ($p \geq 1$). Math. Meth. Appl. Sci. 32 (2008), 135–166.
- [6] *G.-P. Galdi*: An introduction to the mathematical theory of the Navier-Stokes equations. Vol I. Linearized steady problems. Springer, New York, 1994.
- [7] *Donald D. Gray and A. Giorgini*: The validity of the Boussinesq approximation for liquids and gases. Int. J. Heat Mass Transfer 19 (1976), 545–551.
- [8] *M. Giaquinta, L. Modica and J. Souček*: Cartesian Currents in the Calculus of Variations. Vol. I. Cartesian Currents. Springer, Berlin, Heidelberg, 1998.
- [9] *O. Hansen*: The radiosity equation on polyhedral domains. Logos Verlag, Berlin, 2002.
- [10] *A. Kufner, O. John and S. Fučík*: Function spaces. Academia Prague, Prague, 1977.
- [11] *O. Klein, P. Philip and J. Sprekels*: Modelling and simulation of sublimation growth in sic bulk single crystals. Interfaces and Free Boundaries 6 (2004), 295–314.
- [12] *J.-L. Lions*: Quelques méthodes de résolution des problèmes aux limites non linéaires. Dunod, Paris, 1969.
- [13] *O. A. Ladyzhenskaja and V. A. Solonnikov*: Solutions of some non-stationary problems of magnetohydrodynamics for a viscous incompressible fluid. Trudy Mat. Inst. Steklov 59 (1960), 115–173. (In Russian.)
- [14] *M. Laitinen and T. Tiihonen*: Conductive-radiative heat transfer in grey materials. Quart. Appl. Math. 59 (2001), 737–768.
- [15] *A. J. Meir and P. G. Schmidt*: Variational methods for stationary MHD flow under natural interface conditions. Nonlinear Analysis. Theory, Methods and Applications 26 (1996), 659–689.
- [16] *A. J. Meir and P. G. Schmidt*: On electromagnetically and thermally driven liquid-metal flows. Nonlinear analysis 47 (2001), 3281–3294.

- [17] *J. Naumann*: Existence of weak solutions to the equations of stationary motion of heat-conducting incompressible viscous fluids. In *Progress Nonlin. Diff. Eqs. Appl.*, volume 64, pages 373–390, Basel, 2005. Birkhäuser.
- [18] *J.-M. Rakotoson*: Quasilinear elliptic problems with measures as data. *Diff. Integral Eqs.* 4 (1991), 449–457.
- [19] *T. Tiihonen*: Stefan-Boltzmann radiation on non-convex surfaces. *Math. Meth. in Appl. Sci.* 20 (1997), 47–57.
- [20] *A. Voigt*: Numerical Simulation of Industrial Crystal Growth. PhD thesis, Technische-Universität München, Germany, 2001.
- [21] *E. Zeidler*: Nonlinear functional analysis and its applications. II/B. Springer Verlag, New York, 1990.

Author's address: Pierre-Étienne Druet, Weierstrass Institut für Angewandte Analysis und Stochastik, Mohrenstrasse 39, 10117 Berlin, Germany, e-mail: druet@wias-berlin.de.