



## **Experience From the Construction of a New Fast Wire Scanner Prototype for the CERN-SPS and its Optimisation for Installation in the CERN-PS**

Downloaded from: <https://research.chalmers.se>, 2022-08-26 11:18 UTC

Citation for the original published paper (version of record):

Veness, R., Andreatza, W., Chritin, N. et al (2015). Experience From the Construction of a New Fast Wire Scanner Prototype for the CERN-SPS and its Optimisation for Installation in the CERN-PS Booster. Proceedings of the 4th International Beam Instrumentation Conference, IBIC 2015: 479-482

N.B. When citing this work, cite the original published paper.

# EXPERIENCE FROM THE CONSTRUCTION OF A NEW FAST WIRE SCANNER PROTOTYPE FOR THE CERN- SPS AND ITS OPTIMISATION FOR INSTALLATION IN THE CERN-PS BOOSTER

R.Veness, W.Andreazza, N.Chritin, B.Dehning, J.Emery, D.Gudkov, J.Herranz Alvarez, P.Magagnin, E.Piselli, CERN, Geneva, Switzerland  
 S.Samuelsson, CERN, Geneva, Switzerland, on secondment from Chalmers University of Technology, Gothenburg, Sweden

## Abstract

A new design of wire scanner is under development for the LHC Injector Upgrade project at CERN. A prototype has been designed, built and installed in the SPS accelerator to test the concept in an operational environment. New technology has been developed and qualified for in-vacuum motor and structural components using 3D metal additive machining. This paper will describe the technology developed for this scanner and the test results to date.

This prototype has recently been re-optimised to fit in the limited space available in the PS Booster rings. This design will also be presented.

## INTRODUCTION

The LHC Injector Upgrades (LIU) project at CERN [1] covers a wide range of changes to the LHC pre-injectors (LINAC, PS Booster, PS and SPS) to optimise beam emittance and intensity for the future upgrade of the LHC. These improvements will require new beam instrumentation, including transverse profile monitoring for the smaller, brighter beams in all injectors. LIU is scheduled for completion during the next long machine shutdown in 2019-20.

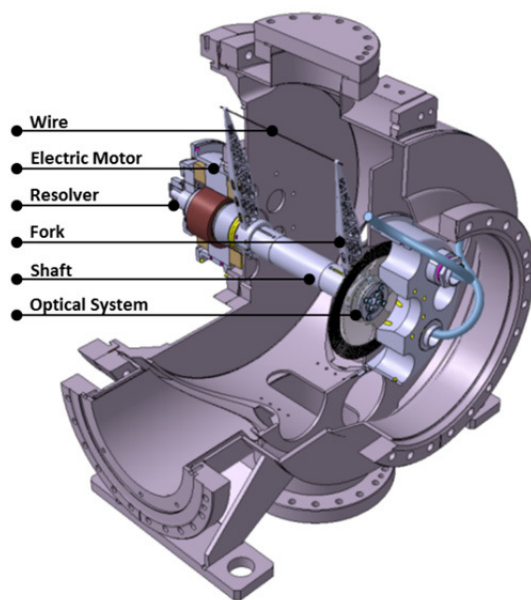

Figure 1: Beam wire scanner for SPS, general view.

A new wire scanner concept, based around an in-vacuum motor rotor is under development [2] to fulfil the LIU requirements. Prototypes have been built, with one installed in the SPS to test performance in an accelerator and the other used for laboratory development and testing. Figure 1 shows a cut away view of the scanner and vacuum tank with the main components labelled.

The PS Booster (PSB) presents the greatest challenge for integration as beams circulate in 4 superimposed concentric rings, with only 360 mm between their centres. The next step in the development is therefore to adapt the SPS prototype concept such that it can be installed in the PSB.

## MOTOR SELECTION

### Requirements

The conceptual design of the beam wire scanner (BWS) uses a frameless electrical motor with the rotor operating in vacuum and stator at atmosphere pressure. The most appropriate type for such applications is a frameless permanent magnet synchronous motor [1].

The device should provide sufficient torque to accelerate the wire to 20 ms<sup>-1</sup> following the accelerating profile shown in Fig. 2 [3].

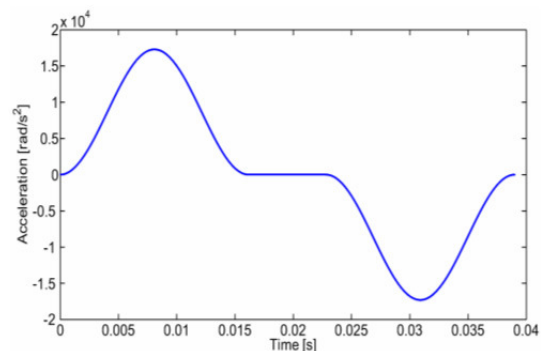

Figure 2: Acceleration profile.

The maximum value of the acceleration is  $\alpha = 15711 \text{ rad.s}^{-2}$  from which the required torque can be calculated using Newton's 2nd law:

$$T = J_{total} \times \alpha.$$

where  $J_{total}$  is the sum of moments of inertia of the load and rotor:

$$J_{total} = J_{load} + J_{rotor}$$

$J_{load}$  is the sum of moments of inertia for all components moved by motor, including the shaft, forks, magnetic brake rotor, optical disk, and bearings. This value for the current BWS design is  $8.6 \times 10^{-4} \text{ kg.m}^2$ .  $J_{rotor}$  is the moment of inertia of the motor rotor itself, with a value that depends on the selected motor.

### Selection

According to current plans, the expected number of motors will not exceed 40 units at the current development phase. However the motor should be available for purchase during the whole lifecycle of the instrument which can exceed 20 years. Hence it was decided to search for a suitable commercial product.

For wire scanner operation the required torque should not exceed peak torque of the motor, i. e. maximum torque the motor can generate for the short periods of time, for example acceleration or deceleration.

A motor with high peak torque and low inertia rotor relatively (compared with other available options) was preselected for detailed study. This model has a rotor with a moment of inertia  $J_{rotor} = 1.28 \times 10^{-3} \text{ kg.m}^2$  and peak torque 55 Nm. Even this low inertia motor represents some 60% of  $J_{total}$ , making motor selection crucial to an optimised instrument design.

The required torque for this case can be calculated using the equation below :

$$T = J_{total} \times \alpha = 31.56 \text{ Nm},$$

which is around 1.75 times less than the specified peak torque for the selected motor. Hence once customised for UHV applications, it was suitable for installation and operation of the BWS instrument to provide the required torque with significant margin.

### Customisation

Standard solutions available on the market are usually not vacuum compatible so the company was requested to perform a customisation of the standard product in order to fulfil the BWS requirements. Vacuum compatibility implies no use of glues, epoxies or other adhesives normally utilized by manufacturers for fixing the permanent magnets to the rotor body. An alternative fixation method like holding them using a thin-walled metallic sleeve (rotor banding) or sliding them into pre-machined wedge-shaped slots on the rotor frame was therefore requested.

Another customisation requested was optimisation of the radial air gap between the external diameter of the rotor and internal diameter of the stator. This value needed to be large enough to allow room for the vacuum chamber with a wall thickness 0.3 mm.

For the permanent magnet material, the best choice for this application is  $\text{Sm}_2\text{Co}_{17}$  as it has a Curie temperature above  $250^\circ\text{C}$  allowing bakeout for achieving ultra-high vacuum (UHV). Furthermore this material is less sensitive to radiation [2].

All the requirements mentioned above were taken into account and implemented to the selected standard model

by the supplier during the customisation phase. Being one of the core company products it is hoped that this type of motor will remain available for purchase in the coming years.

## DESIGN AND MANUFACTURE OF FORKS

The forks serve to support the wire under tension while it is moved across the beam by the rotation of the shaft. Their design is therefore very important for the final performance. They must be rigid enough to keep the wire under tension in the plane parallel to the shaft and minimise deformation or vibration due to acceleration in the plane perpendicular to the shaft. They must also be optimised to minimise the inertial load on the motor during acceleration and deceleration of the wire.

As these requirements were readily quantifiable and the base geometry rather simple, it was a good candidate for automated topological optimisation. A number of commercially available software tools were used to make firstly 2D then 3D optimisation of the fork shape, iteratively removing material to converge towards an optimum for the given loads and displacement maxima [4].

The topology proposed by this optimisation was then implemented in the ANSYS finite element package and refined to conform to requirements of stiffness and vibration modes.

The resulting 3D model was then adapted for manufacture by laser-sintered 3D additive machining which imposes some constraints on the geometry. Forks were produced in one piece from titanium ( $\text{TiAlV6}$ ) powder with a wall thickness of 0.4 mm by a specialist manufacturer with precision details post-machined at CERN.

Images from the four stages of the process: optimisation; analysis; 3D manufacture and post-machined structure are shown in figure 3.

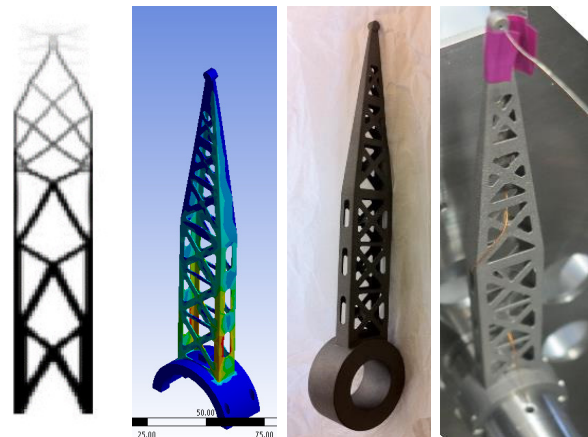

Figure 3: Design and manufacture process of forks.

## QUALIFICATION OF MATERIALS FOR VACUUM

The wire scanner will operate in a UHV environment requiring all of the in-vacuum parts of the instrument to be UHV compatible.

A measurement campaign was performed to measure and qualify each component as well as the fully-assembled instrument. Special attention was given to components that are not normally used for UHV applications.

The residual gas analysis and outgassing rate measurements of the samarium cobalt permanent magnets, three type of bearings (metallic, hybrid and fully ceramic), optical fibres and optical components showed that they are all UHV- compatible and can thus be used in an accelerator environment.

Once the wire scanner prototype was ready and fully assembled a final measurement to check the vacuum compatibility was performed. This last test showed a much higher outgassing rate (not expected after the individual component measurements). This is suspected to be due to Kapton cables used to measure wire resistance or some contamination during the final assembly. Further tests are in progress.

An additional vacuum pump was added onto the instrument tank (a flange was already planned for such a device) to reach the required vacuum pressure.

## PROTOTYPE VALIDATION PRIOR TO INSTALLATION

The functional validation of the prototypes and first actuator performance checks were performed on a dedicated test bench. This bench uses a control prototyping system called DSpace, based on MatLab/Simulink tools to design and validate the future motion control architecture and optimise its parameters for optimal performance. It was first used in [5] and then redesigned and optimized recently in [6].

Multiple mechanical configurations have been tested and compared against each other to provide an in-depth understanding of the dynamic behaviour of the scanner. This setup allows fine tuning of system parameters using the final assembly to achieve the required performance. Using the angular sensor of the motor control to measure the angular position of the shaft showed that the nominal speed and expected position are reproduced consistently. Figure 4 shows the position of the scanner prototype as the shaft rotates by  $\pi$  radians to the 'in' position and then back to the 'out' position over a very rapid 0.3 second cycle. This graph consists of 6 repeated in-out cycles superimposed on the same graph. Figure 5 shows the speed of the shaft, calculated by on-line processing using Kalman filtering techniques, also with 6 cycles superimposed. The position and speed can be seen to be very reproducible but not completely flat at maximum speed. Further optimisation of system parameters is foreseen to improve this issue.

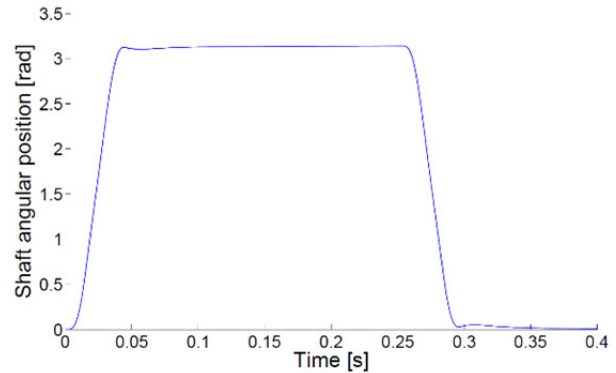

Figure 4: Shaft position with 6 superimposed scan cycles.

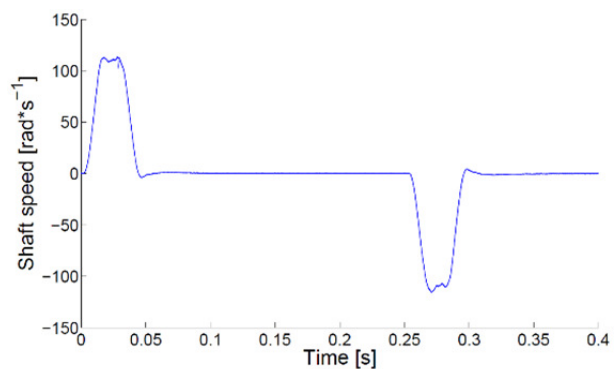

Figure 5: Shaft speed with 6 superimposed scan cycles.

Following this first phase, more than 70'000 cycles have been run to verify the stability of the movement cycle over extended periods of use. Preliminary results have shown a good stability even with a demanding cycle rate as short as one scan every 3 seconds. These very encouraging results give confidence for the expected performance of the scanner installed in the SPS accelerator.

This cyclic testing has also served as a preliminary validation of the moving mechanical components (bearings, forks, and shaft) which showed no sign of wear or damage, with the exception of some colouring of the bearings which is under investigation.

## PROTOTYPE INSTALLATION AND TESTING IN THE SPS MACHINE

The prototype was integrated into the SPS LSS5 where a suitable space was available with low activation levels, easy access and appropriate beam size.

The beam wire scanner tank was installed and aligned in May 2014, during the long accelerator stop with the instrument itself installed during a shorter stop in January 2015.

The first functional testing of the scanner in the SPS accelerator is foreseen to take place before the end of 2015 with custom electronics as described in [7] instead of the development platform used on test the benches.

## OPTIMISING THE DESIGN FOR THE PSB

The PS Booster ring is composed of four vertically stacked synchrotron beamlines that currently receives a proton beam at 50 MeV from the LINAC 2, and accelerates it up to 1.4 GeV before injecting it into the PS. LIU will increase these energies to 160 MeV injection into the PSB from the new LINAC4 and 2 GeV from PSB to an upgraded PS.

These four rings are stacked with an inter-axis distance of 360 mm, and have a beam aperture of 80 mm x 120 mm. This configuration, together with a longitudinal available space of 1000 mm for fitting a total of eight wire scanners, represents a major design constraint. The original design for the SPS has therefore been modified to fit in the limited available space.

The conceptual phase aimed to have the same design for horizontal and vertical wire scanner, using standard components with access to all instruments from the passage side of the ring, to allow easy maintenance.

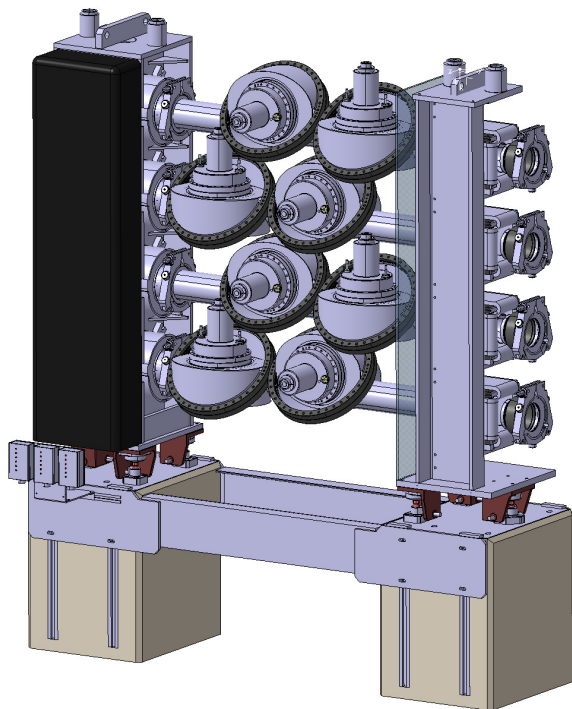

Figure 6: Possible BWS integration in the Booster.

The precisely machined drum used in the SPS design has been removed, making the shaft cantilevered. The optical system is shifted close to the motor and the shaft re-optimised in order to increase its stiffness while reducing the inertia. Stainless steel has been retained as the shaft material to maximise the ratio of shear modulus to mass density while still keeping the possibility to bake out the system.

The position of the optical sensors requires a large optical disc, which, if made out of glass would need custom manufacture, as well as being rather fragile under

the extremely high acceleration of the system. Therefore, a metallic optical disc is under development in collaboration with Dundee University, UK.

The thickness of the vacuum chamber required between stator and the rotor has been optimised to 0.3 mm in order to integrate a commercial motor whilst remaining practical to manufacture.

However, despite these modification, integration is extremely problematic, as shown in Figure 6. The possibility of putting H and V scanners in different sectors of the machine is under investigation, which would make more space available and also allow for simultaneous scans in both planes.

## CONCLUSIONS AND NEXT STEPS

Two prototype wire scanners based on an in-vacuum, directly coupled motor have been designed and built, with one installed for test in the SPS accelerator. Preliminary testing in the lab has validated the mechanics, control system and performance, with more than 70'000 scans successfully completed.

Modification to this design allowing for integration in the PSB is now in progress.

Production of a small prototype series is expected to start in early 2016, with installation in the PSB in early 2017, during a machine technical stop.

LIU will require a total of 18 of these new scanners to be installed across the injector complex during the period 2019-2020. A robust and cost-effective engineering of both mechanics and control system will therefore be required before series production.

## REFERENCES

- [1] K. Hanke et al. "Status of the LIU project at CERN", Proc. IPAC 2014, Dresden, Germany.
- [2] R.Veness et al. "Design of a high-precision fast wire scanner for the SPS at CERN", Proc. IBIC 2012, Tsukuba, Japan.
- [3] M. Koujili "Design and construction of a new actuator for the LHC Wire Scanner", PhD thesis in Electrical Engineering.
- [4] S.Samuelsson. 'Mechanical optimisation of a high-precision fast wire scanner at CERN'. CERN-THESIS-2013-112.
- [5] C. Grosjean, "Motor and Break Design for the Wire Scanner", Bachelor thesis, Heig-vd, Yverdon-les-bains, 2014, CERN EDMS 1416824.
- [6] M. Macchini, "Motion control design of a PMSM and FPGA implementation for the Beam Wire Scanner at CERN", Master thesis, University of Pisa, 2015, CERN-THESIS-2015-055.
- [7] J. Emery, "Beam Scanner Control, Monitoring and Supplies", Engineering specification, CERN EDMS No 1318827.