

NACA-TR
660

Arthur E. Rouland
University of Detroit

**NATIONAL ADVISORY COMMITTEE
FOR AERONAUTICS**

REPORT No. 660

**EXPERIMENTAL INVESTIGATION OF THE
MOMENTUM METHOD FOR DETERMINING
PROFILE DRAG**

By **HARRY J. GOETT**



The Garrett Corporation
Air Research Mfg. Div.

SEP 2 1975

LIBRARY

1939

AERONAUTIC SYMBOLS

1. FUNDAMENTAL AND DERIVED UNITS

	Symbol	Metric		English	
		Unit	Abbreviation	Unit	Abbreviation
Length.....	<i>l</i>	meter.....	m	foot (or mile).....	ft. (or mi.)
Time.....	<i>t</i>	second.....	s	second (or hour).....	sec. (or hr.)
Force.....	<i>F</i>	weight of 1 kilogram.....	kg	weight of 1 pound.....	lb.
Power.....	<i>P</i>	horsepower (metric).....		horsepower.....	hp.
Speed.....	<i>V</i>	kilometers per hour.....	k.p.h.	miles per hour.....	m.p.h.
		meters per second.....	m.p.s.	feet per second.....	f.p.s.

2. GENERAL SYMBOLS

<p><i>W</i>, Weight = mg</p> <p><i>g</i>, Standard acceleration of gravity = 9.80665 m/s² or 32.1740 ft./sec.²</p> <p><i>m</i>, Mass = $\frac{W}{g}$</p> <p><i>I</i>, Moment of inertia = mk^2. (Indicate axis of radius of gyration <i>k</i> by proper subscript.)</p> <p><i>μ</i>, Coefficient of viscosity</p>	<p><i>ν</i>, Kinematic viscosity</p> <p><i>ρ</i>, Density (mass per unit volume)</p> <p>Standard density of dry air, 0.12497 kg-m⁻³-s² at 15° C. and 760 mm; or 0.002378 lb.-ft.⁻³ sec.²</p> <p>Specific weight of "standard" air, 1.2255 kg/m³ or 0.07651 lb./cu. ft.</p>
--	---

3. AERODYNAMIC SYMBOLS

<p><i>S</i>, Area</p> <p><i>S_w</i>, Area of wing</p> <p><i>G</i>, Gap</p> <p><i>b</i>, Span</p> <p><i>c</i>, Chord</p> <p><i>b²</i>, Aspect ratio</p> <p><i>V</i>, True air speed</p> <p><i>q</i>, Dynamic pressure = $\frac{1}{2}\rho V^2$</p> <p><i>L</i>, Lift, absolute coefficient $C_L = \frac{L}{qS}$</p> <p><i>D</i>, Drag, absolute coefficient $C_D = \frac{D}{qS}$</p> <p><i>D₀</i>, Profile drag, absolute coefficient $C_{D_0} = \frac{D_0}{qS}$</p> <p><i>D_i</i>, Induced drag, absolute coefficient $C_{D_i} = \frac{D_i}{qS}$</p> <p><i>D_p</i>, Parasite drag, absolute coefficient $C_{D_p} = \frac{D_p}{qS}$</p> <p><i>C</i>, Cross-wind force, absolute coefficient $C_C = \frac{C}{qS}$</p> <p><i>R</i>, Resultant force</p>	<p><i>i_w</i>, Angle of setting of wings (relative to thrust line)</p> <p><i>i_s</i>, Angle of stabilizer setting (relative to thrust line)</p> <p><i>Q</i>, Resultant moment</p> <p><i>Ω</i>, Resultant angular velocity</p> <p>$\rho \frac{Vl}{\mu}$, Reynolds Number, where <i>l</i> is a linear dimension (e.g., for a model airfoil 3 in. chord, 100 m.p.h. normal pressure at 15° C., the corresponding number is 234,000; or for a model of 10 cm chord, 40 m.p.s., the corresponding number is 274,000)</p> <p><i>C_p</i>, Center-of-pressure coefficient (ratio of distance of c.p. from leading edge to chord length)</p> <p><i>α</i>, Angle of attack</p> <p><i>ε</i>, Angle of downwash</p> <p><i>α₀</i>, Angle of attack, infinite aspect ratio</p> <p><i>α_i</i>, Angle of attack, induced</p> <p><i>α_a</i>, Angle of attack, absolute (measured from zero-lift position)</p> <p><i>γ</i>, Flight-path angle</p>
--	---

REPORT No. 660

**EXPERIMENTAL INVESTIGATION OF THE MOMENTUM
METHOD FOR DETERMINING PROFILE DRAG**

By HARRY J. GOETT

Langley Memorial Aeronautical Laboratory

NATIONAL ADVISORY COMMITTEE FOR AERONAUTICS

HEADQUARTERS, NAVY BUILDING, WASHINGTON, D. C.

LABORATORIES, LANGLEY FIELD, VA.

Created by act of Congress approved March 3, 1915, for the supervision and direction of the scientific study of the problems of flight (U. S. Code, Title 50, Sec. 151). Its membership was increased to 15 by act approved March 2, 1929. The members are appointed by the President, and serve as such without compensation.

JOSEPH S. AMES, Ph. D., *Chairman*,
Baltimore, Md.

VANNEVAR BUSH, Sc. D., *Vice Chairman*,
Washington, D. C.

CHARLES G. ABBOT, Sc. D.,
Secretary, Smithsonian Institution.

HENRY H. ARNOLD, Major General, United States Army,
Chief of Air Corps, War Department.

GEORGE H. BRETT, Brigadier General, United States Army,
Chief Matériel Division, Air Corps, Wright Field, Dayton,
Ohio.

LYMAN J. BRIGGS, Ph. D.,
Director, National Bureau of Standards.

CLINTON M. HESTER, A. B., LL. B.,
Administrator, Civil Aeronautics Authority.

ROBERT H. HINCKLEY, A. B.,
Chairman, Civil Aeronautics Authority.

JEROME C. HUNSAKER, Sc. D.,
Cambridge, Mass.

SYDNEY M. KRAUS, Captain, United States Navy,
Bureau of Aeronautics, Navy Department.

CHARLES A. LINDBERGH, LL. D.,
New York City.

FRANCIS W. REICHELDERFER, A. B.,
Chief, United States Weather Bureau.

JOHN H. TOWERS, Rear Admiral, United States Navy,
Chief, Bureau of Aeronautics, Navy Department.

EDWARD WARNER, Sc. D.,
Greenwich, Conn.

ORVILLE WRIGHT, Sc. D.,
Dayton, Ohio.

GEORGE W. LEWIS, *Director of Aeronautical Research*

JOHN F. VICTORY, *Secretary*

HENRY J. E. REID, *Engineer-in-Charge, Langley Memorial Aeronautical Laboratory, Langley Field, Va.*

JOHN J. IDE, *Technical Assistant in Europe, Paris, France*

TECHNICAL COMMITTEES

AERODYNAMICS
POWER PLANTS FOR AIRCRAFT
AIRCRAFT MATERIALS

AIRCRAFT STRUCTURES
AIRCRAFT ACCIDENTS
INVENTIONS AND DESIGNS

Coordination of Research Needs of Military and Civil Aviation

Preparation of Research Programs

Allocation of Problems

Prevention of Duplication

Consideration of Inventions

LANGLEY MEMORIAL AERONAUTICAL LABORATORY
LANGLEY FIELD, VA.

OFFICE OF AERONAUTICAL INTELLIGENCE
WASHINGTON, D. C.

Unified conduct, for all agencies, of scientific research on the fundamental problems of flight.

Collection, classification, compilation, and dissemination of scientific and technical information on aeronautics.

REPORT No. 660

EXPERIMENTAL INVESTIGATION OF THE MOMENTUM METHOD FOR DETERMINING PROFILE DRAG

By HARRY J. GOETT

SUMMARY

An experimental investigation has been conducted in the full-scale tunnel to determine the accuracy of the Jones and the Betz equations for computing profile drag from total- and static-pressure surveys in the wake of wings. Surveys were made behind 6- by 36-foot airfoils of the N. A. C. A. 0009, 0012, and 0018 sections at zero lift and behind the N. A. C. A. 0012 airfoil at positive lifts. The surveys were made at various spanwise positions and at distances behind the airfoil ranging from $0.05c$ to $3.00c$.

The reduction of the test data by either the Jones or the Betz equation gave profile-drag coefficients agreeing within 2 percent with those obtained by force tests at zero lift. The variation of the profile drag determined at stations from $0.05c$ to $3.00c$ behind the trailing edge was small and the error resulting from the induced field of a lifting airfoil did not exceed 2.5 percent at a C_L of 1.0 and a spanwise station of $0.78 b/2$.

INTRODUCTION

The use of the momentum method for the determination of profile drag has recently increased, owing mainly to the equations developed by Betz (reference 1) and by Jones (reference 2) by which the method has been made applicable in the region of increased static pressure close behind a body. The derivation of these equations, which are based on the original principle stated by Froude in 1874, requires certain assumptions. The errors introduced by these assumptions have been the subject of theoretical analyses (references 2 and 3), which have set an upper limit for the errors involved but fail to define their actual value.

The investigation reported herein was conducted to determine experimentally the magnitude of these errors by determining the effect of a number of variables upon the measured drag. (See reference 4.) The necessary wake surveys were made in the N. A. C. A. full-scale wind tunnel behind symmetrical airfoils of three thickness ratios. The effect of distance behind the airfoils was first investigated by a comparison of drag determinations made at locations ranging from $0.05c$ to $3.00c$ behind the trailing edge. A check was then obtained on the accuracy of the method by a comparison

with force-test drag measurements at zero lift. Finally, the effect of the induced-flow system of a lifting wing was investigated.

SYMBOLS

The symbols used in the report are defined as follows:

- H_0 , free-stream total pressure.
- H_1, H_2, H_3 , total pressures in field of airfoil. (See fig. 4.)
- p_0 , free-stream static pressure.
- p_1, p_2, p_3 , static pressures in field of airfoil.
- q_0 , free-stream dynamic pressure, $1/2\rho U_0^2$.
- U_0 , free-stream velocity.
- U_1, U_2, U_3 , local velocity in field of airfoil.
- U_2' , hypothetical velocity in wake (Betz equation).
- y , vertical coordinate of point.
- c , airfoil chord.
- dS, dS_1, dS_2, dS_3 , elemental areas.
- ρ , density.
- b , airfoil span.
- v , velocity along the Y axis.
- w , velocity along the Z axis.
- D_0 , airfoil profile drag.
- C_{D_0} , airfoil profile-drag coefficient.
- c_{d_0} , section profile-drag coefficient.
- C_L , airfoil lift coefficient.
- c_l , section lift coefficient.

EXPERIMENTAL INVESTIGATION

APPARATUS

The experimental work was conducted in the N. A. C. A. full-scale wind tunnel (reference 5). This tunnel has a turbulence factor of 1.1 as determined by sphere tests (reference 6). A typical static-pressure gradient along the axis of the tunnel (jet empty) is shown in figure 1. This gradient was allowed for in determining the free-stream reference pressure for the momentum measurements. The buoyancy effect of the gradient is small.

Three 6- by 36-foot rectangular airfoils having N. A. C. A. 0009, 0012, and 0018 sections were used in these tests. The airfoils, which were covered with

$\frac{1}{16}$ -inch aluminum sheets, had all the screw heads filled and the surface painted, sanded, and polished to a glossy waxlike finish to insure aerodynamic smoothness. The airfoil tips were rounded, each tip forming one-half of a solid of revolution with the radius at each chordwise station equal to one-half the local airfoil thickness. Figure 2 shows one of the airfoils mounted in the tunnel jet.

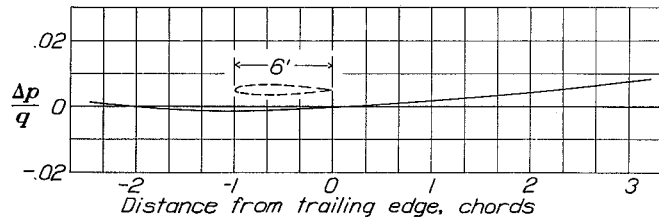

FIGURE 1.—Typical static-pressure gradient along test section of full-scale wind tunnel (jet empty).

The rack used for the total- and the static-pressure surveys consisted of a comb of 39 total-pressure tubes and one of 13 static-pressure tubes. These combs were spaced 6 inches laterally and the entire assembly was mounted on the survey carriage. The detailed spacing and the dimensions of the tubes on both combs are shown in figure 3. Each tube was connected to a multiple-tube, photographic-recording manometer carried in the survey carriage.

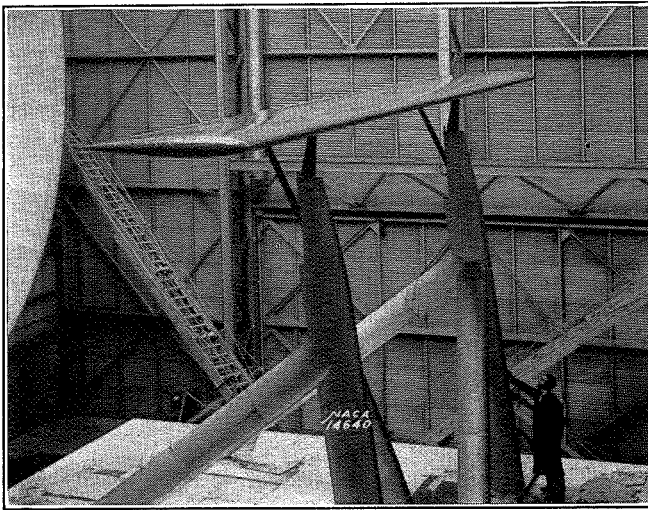

FIGURE 2.—The 6-by-36-foot N. A. C. A. 0012 airfoil mounted in the full-scale wind tunnel.

METHOD

A survey was first made with the total- and the static-pressure combs at each station of measurement with the jet empty. This survey established the total-pressure and the static-pressure gradients in the tunnel at the points of measurement. Pitch-angle surveys were next made behind the airfoils to establish the average downwash angle across the field of measurement. Total-pressure and static-pressure readings were then taken in the wake region with the rack perpendicular to the average downwash direction at each station.

This procedure kept the effect of flow angularity on the measurements at a minimum, since the local angle across the rack varied no more than $\pm 3^\circ$ from the average. The effect of periodic pressure fluctuations in the tunnel jet was eliminated by the instantaneous readings taken on the photographic manometer.

SCOPE OF TESTS

Pressure and drag measurements were made at locations and under conditions as follows:

1. Total- and static-pressure surveys were made at zero lift behind the three airfoils at 27 spanwise loca-

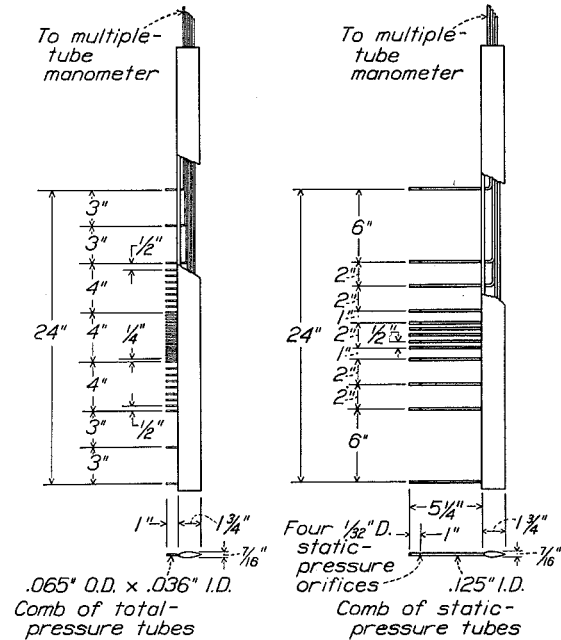

FIGURE 3.—Combs of total- and static-pressure tubes.

tions, $0.15c$ behind the trailing edge. At the $0.06 b/2$ station, surveys were obtained at longitudinal stations varying from $0.05c$ to $3.00c$ behind the trailing edge. Force tests were made to furnish comparative drag data.

2. Total- and static-pressure surveys were obtained behind the N. A. C. A. 0012 airfoil at lift coefficients of 0, 0.28, 0.47, 0.65, 0.83, and 1.13 at six spanwise locations, $0.15c$ and $0.30c$ behind the trailing edge. Force tests were made to furnish comparative drag data.

All tests were run at an air speed of 90 miles per hour, giving a test Reynolds Number of 5,000,000.

THEORY

The profile drag of a body can be determined from the loss of momentum per unit time that it imposes upon the free stream. If a region exists behind the body where the static pressure has returned to that of the free stream (fig. 4 (c)), the profile drag of a nonlifting body will be given by the expression

$$D_0 = \rho \int^W \int U_3 (U_0 - U_3) dS \quad (1)$$

where W indicates that the integration is confined to the wake region. For practical reasons, it is desirable

in most cases to make the survey in the region close behind the airfoil where p is in excess of p_0 (fig. 4 (b)). In this region the drag will be equal to

$$D_0 = \iint (p_1 + \rho U_1^2) dS_1 - \iint (p_2 + \rho U_2^2) dS_2 \quad (2)$$

where both integrations are carried to infinity.

Since it is impossible to survey to infinity as required by equation (2), this equation must be transformed into one involving only quantities in the wake region. This transformation has been made by Betz (reference 1) and by Jones (reference 2).

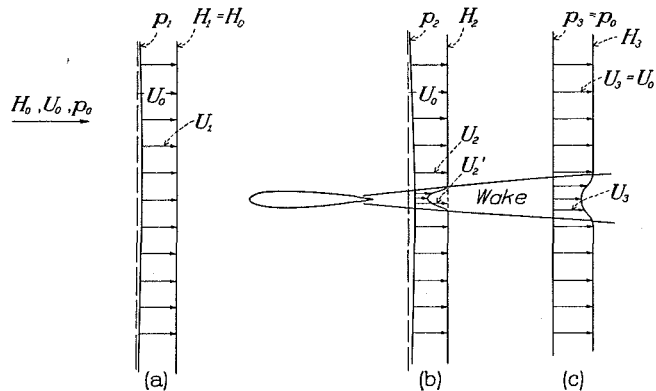

FIGURE 4.—Diagram of airfoil and wake.

$$c_{d_0} = \frac{1}{c} \int^w \left[\frac{H_0 - H_2}{H_0 - p_0} \right] + \left[\frac{(\sqrt{H_0 - p_2} - \sqrt{H_2 - p_2})(\sqrt{H_0 - p_2} + \sqrt{H_2 - p_2} - 2\sqrt{H_0 - p_0})}{H_0 - p_0} \right] dy \quad (4)$$

The last step involves the assumption that, for a lifting airfoil,

$$H_2 = \frac{1}{2} \rho U_2^2 + p_2 \quad (5)$$

instead of

$$H_2 = \frac{1}{2} \rho (U_2^2 + v_2^2 + w_2^2) + p_2 \quad (6)$$

Jones (reference 2) assumes a hypothetical flow in the wake in which there is no energy interchange between tubes of flow in the wake behind the point of measurement and consequently that Bernoulli's equation may be applied to these tubes of flow. On the basis of such an assumption, the total and the static pressures measured close behind a body in a region of increased static pressure give sufficient data to obtain the corresponding velocity loss (and therefore momentum defect) at a point where the static pressure has reached the free-stream value. Thus on a non-lifting airfoil,

$$D_0 = \rho \int^w \int U_2 (U_0 - U_3) dS \quad (7)$$

and (on the foregoing assumption)

$$H_2 - p_0 = \frac{1}{2} \rho U_3^2 \quad (8)$$

Then

$$D_0 = 2 \int^w \int \sqrt{H_2 - p_2} (\sqrt{H_0 - p_0} - \sqrt{H_2 - p_0}) dS \quad (9)$$

Betz builds up a hypothetical flow by means of a system of sources of such strength that the total pressure in the wake of the body is restored to the value it would have in potential flow. (See fig. 4, $H_2 = H_0$, $U_2 = U_2'$.) This system has a resultant thrust equal to the thrust of the sources. It differs from the real system only in the region of the wake so that the difference in thrust between the two systems is equal to the difference in momentum per unit time passing through the wake region of each. It then follows that

Drag of real system = (Difference in thrust between hypothetical and real systems) - (Thrust of hypothetical system)

Thus, the integration over the region external to the wake is eliminated and the expression for profile drag reduces to

$$D_0 = \int^w \int (H_0 - H_2) dS + \frac{\rho}{2} \int^w \int (U_2' - U_2)(U_2' + U_2 - 2U_0) dS \quad (3)$$

In terms of total and static pressures to be measured, the section profile-drag coefficient becomes

Reduced to coefficient form, equation (9) becomes

$$c_{d_0} = \frac{2}{c} \int^w \frac{\sqrt{H_2 - p_2}}{\sqrt{H_0 - p_0}} \left(1 - \frac{\sqrt{H_2 - p_0}}{\sqrt{H_0 - p_0}} \right) dy \quad (10)$$

which Jones also applies to a lifting airfoil.

The effect of the assumptions made in the derivation of the Betz and the Jones equations has received considerable study. The errors involved in the method of Betz are difficult to estimate and the validity of the derivation is difficult to establish.

Taylor (reference 3) has shown that the neglect in the Jones method of the internal tangential stresses ("mixing") which occur in the wake downstream of the measured section is theoretically unsound. From the examination of a number of typical profiles, Taylor has shown that the error does not exceed 1.5 percent but he also shows that much larger errors are possible.

The induced field of a finite lifting wing may cause errors in the methods. First, the assumption made in equation (5), that the v and the w components may be neglected, will be a source of error. Second, there is the possibility that the vortices in the wake region may damp out causing a loss of total pressure, which appears erroneously as profile drag. An analysis of this possibility, based on certain typical wake profiles, has been made by Jones in reference 2 and the maximum value of the error due to this possible pressure loss has been estimated.

In addition to the foregoing errors, inaccuracies will possibly arise from incorrect readings of static and total pressures caused by turbulence and stream angularities behind the airfoil.

RESULTS AND DISCUSSION

COMPUTATION OF RESULTS

In the computation of results, the values of H_2 and p_2 across the wake profile were determined from faired curves of total and static pressures, to which a correction was applied to allow for the vertical gradients existing in the tunnel. The values of H_0 and p_0 were determined from readings taken well outside the wake with a correction applied to obtain the values of these quantities at the position of the airfoil. These values were then substituted in equations (4) and (10) and the results were plotted against the vertical position in the wake. The resulting curve was integrated, the summation being the section profile-drag coefficient at the station of measurement. An additional correction was applied for displacement of the effective center of the total-pressure tubes in a velocity gradient.

EFFECT OF DISTANCE BEHIND THE AIRFOIL

The variation in measured drag with distance behind the airfoil is shown in figure 5 for the three airfoils at a c_l of 0.05 and for the N. A. C. A. 0012 at values of c_l of 0.78 and 1.32. Each point is the average of results

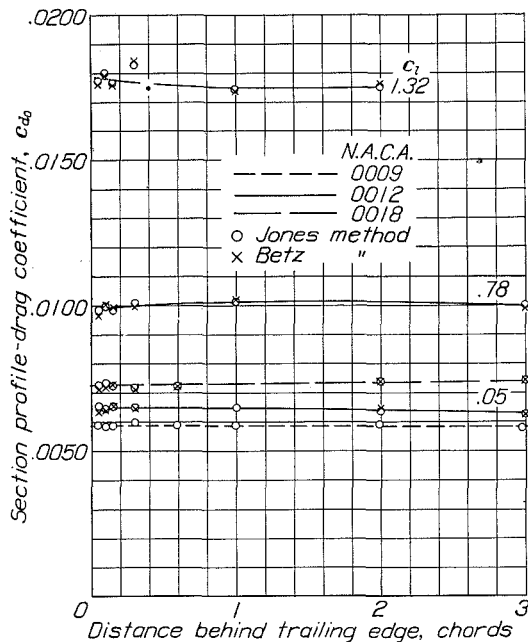

FIGURE 5.—Variation of measured drag with distance behind the airfoil.

from two or more surveys. The curves show that the greatest difference in drag, as measured at the foremost and the rearmost positions, is approximately 3 percent. This difference is within the experimental scatter of the measurements, estimated to vary from ± 1 percent at the $0.15c$ station to ± 3 percent at the $3.00c$ station (where the wake profiles are shallow and

wide). It is therefore concluded that the measured drag, as evaluated by either the Jones or the Betz method, is unaffected by distance behind the airfoil within the accuracy of the measurements.

Figure 5 also indicates that there is no significant difference between the drag as determined by the Betz and the Jones equations. The maximum spread between the two methods is less than 1 percent. All

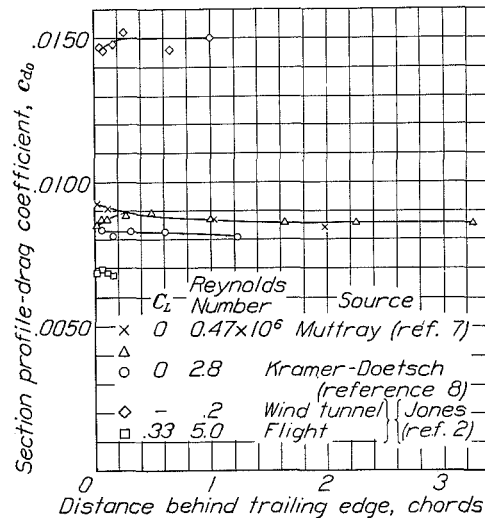

FIGURE 6.—Results of drag determinations obtained by the momentum method by Muttray, Kramer and Doetsch, and Jones.

further drag determinations were therefore made by the Jones equation because of the greater simplicity of the necessary computations.

The results of other similar investigations (references 2, 7, and 8) are shown in figure 6. From these results, Muttray concluded (reference 7) that sufficient data had not yet been obtained to warrant the conclusion that the measured drag was independent of the distance behind the airfoil. The present investigation is considered, however, to have furnished sufficient data to support this conclusion.

EFFECT OF TURBULENCE ON STATIC-PRESSURE MEASUREMENTS

In relation to the possible effect of turbulence on the measurement of static pressure in the wake, a comparison of measured static pressures with computed static pressures behind the N. A. C. A. 0012 and 0018 airfoils at zero lift is shown in figure 7. The pressures behind the airfoils at zero lift were computed for the case of ideal flow about the airfoils and for flow with a boundary layer and a wake by means of a source-sink distribution to represent the airfoil and the wake.

COMPARISON OF MOMENTUM- AND FORCE-TEST RESULTS

The accuracy of the momentum method is indicated from a direct comparison with force-test results. The drag coefficients obtained from momentum surveys at 27 spanwise locations at $0.15c$ behind the three airfoils at zero lift are plotted in figure 8. These curves, when integrated across the span, give an over-all C_{D_0} for each airfoil. The drag coefficients obtained in this

TABLE I
COMPARISON OF PROFILE-DRAG COEFFICIENTS AT
ZERO LIFT OBTAINED FROM MOMENTUM AND
FORCE TESTS

N. A. C. A. airfoil	C_{D_0}		Difference (percent)
	Momen- tum test	Force test	
0009	0.0061	0.0060	1.7
0012	.0066	.0065	1.6
0018	.0075	.0076	1.3

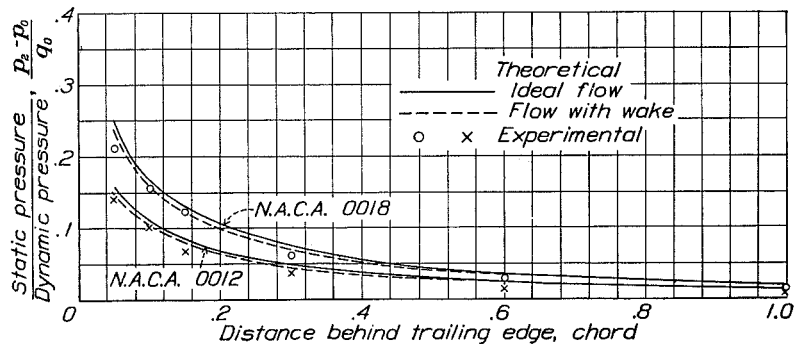

FIGURE 7.—Experimental and theoretical static-pressure variation behind the N. A. C. A. 0012 and 0018 airfoils at zero lift.

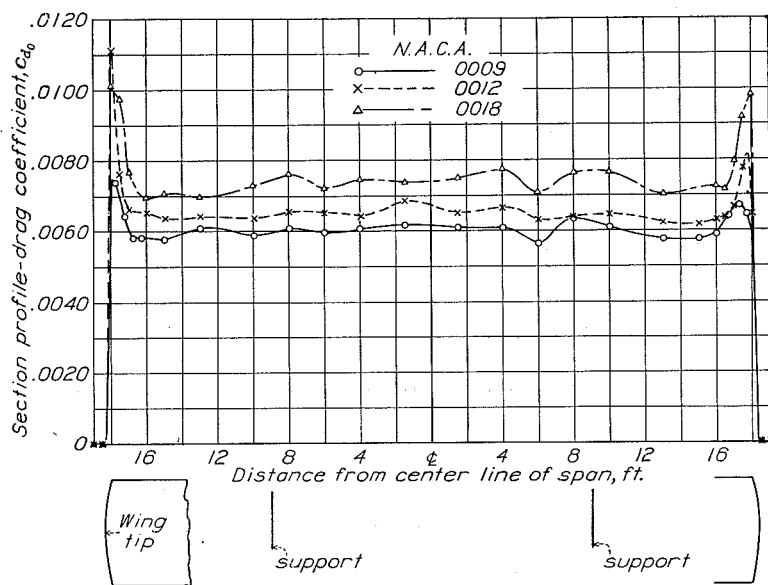

FIGURE 8.—Variation of section profile-drag coefficient across the span of the rounded-tip airfoils at zero lift.

manner are compared with those measured by force tests in table I. The maximum difference is less than 2 percent, indicating the order of accuracy of the momentum method. A similar comparison cannot be made at positive lifts because it is impossible to obtain results from the momentum method in the region of the airfoil tips owing to the intensity of the vortices.

EFFECT OF INDUCED FLOW

The total effect of the errors caused by the induced-flow field of a lifting airfoil may be determined from a comparison of the curves of section profile-drag coeffi-

cient against section lift coefficient obtained under the various conditions of induced flow that exist between the center line and the tip of a finite airfoil at positive lifts. Such curves are given in figure 9 for six spanwise locations from 0.06 to 0.90 $b/2$. The section lift coefficients were computed on the basis of a lift distribution given by Glauert (reference 9), which was found to check well with pressure-distribution tests. These curves, having been slightly shifted in order to make them agree at zero lift, are superimposed in figure 10. It will be noted that, out to 0.78 $b/2$ and up to a c_l of 1.0, the maximum dispersion is ± 2.5 percent from the 0.06 $b/2$ curve. This variation compares with a difference of approximately 7 percent that is indicated by Jones' analysis, which is based on the assumption of complete damping out of the vortices (reference 2). Inasmuch as part of the dispersion in figure 10 is due to experimental scatter, the ± 2.5 percent is considered a conservative estimate of the effect of the induced field upon the measurements. At the 0.90 $b/2$ station, the distorted curve indicates that, above a section lift coefficient of zero, the air-stream angularities become such as to make the measurements unreliable.

COMPARISON OF MOMENTUM- AND FORCE-TEST RESULTS AT POSITIVE LIFTS

A direct comparison between drag results obtained from momentum and force tests of a lifting airfoil is impossible because of the failure of the momentum method near the tip as well as the inclusion of induced drag in the force-test measurements. If the induced drag is deducted from the force-test drag, however, the two methods should give results differing only by the drag contributed by the tips. Such a comparison has been made in figures 11 and 12. A plot of profile drag (determined by the momentum method) against span-wise position is given in figure 11; the curves were extrapolated in the tip region and no allowance was made for an increase in drag at the tips. Integration of these curves across the span gives the average profile-drag coefficient C_{D_0} , which has been plotted against C_L in figure 12. The result is compared with the profile-drag coefficient determined from force tests in the usual manner (i. e., by deducting the computed induced drag). A curve of section characteristics obtained by the momentum method (0.06 $b/2$ curve from fig. 10) is also given to show the comparison with the average profile drag across the span.

An appreciable spread will be noted between the momentum- and the force-test results; the difference varies from 1 percent at zero lift to 22 percent at a C_L of 1.0. A number of causes other than tip effects

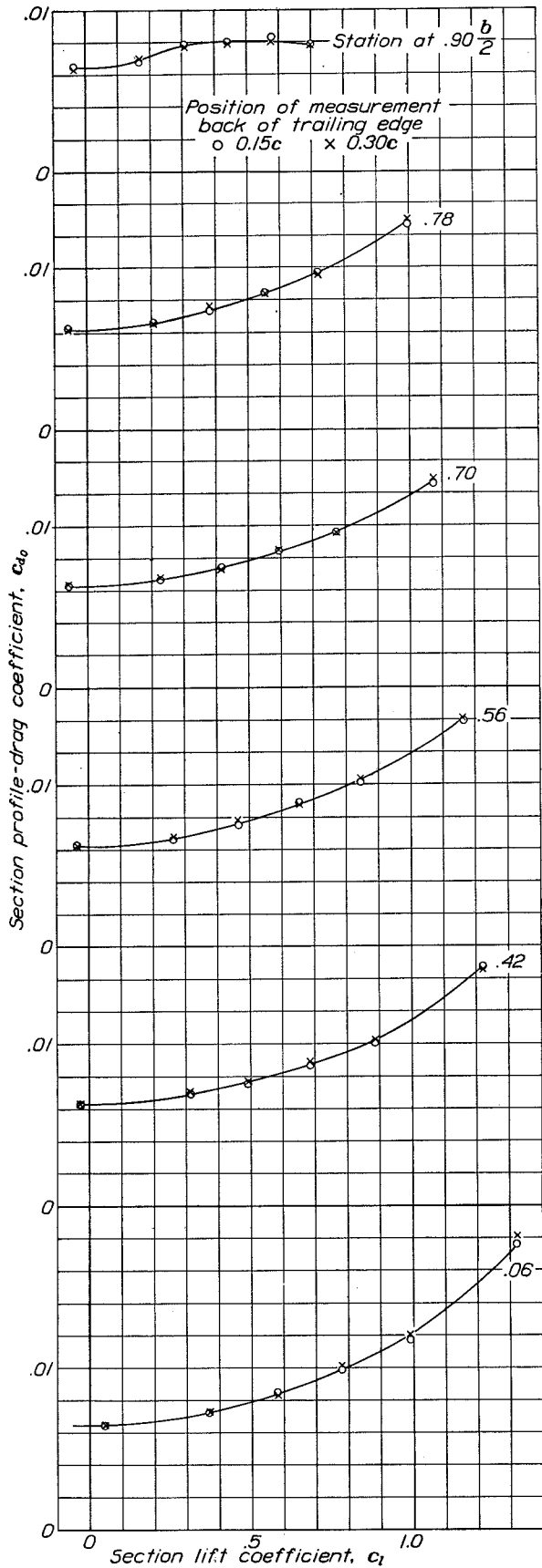

FIGURE 9.—Variation of c_{d0} with c_l from wake surveys at several spanwise stations. N. A. C. A. 0012 airfoil.

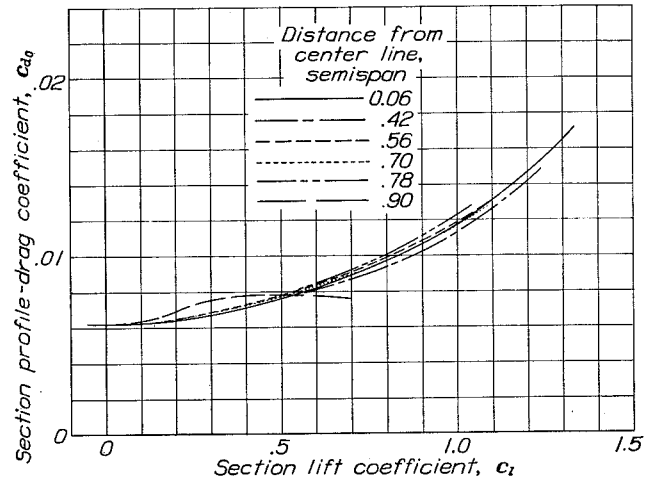

FIGURE 10.—Comparison of curves of c_{d0} against c_l obtained from wake surveys at several spanwise stations. N. A. C. A. 0012 airfoil.

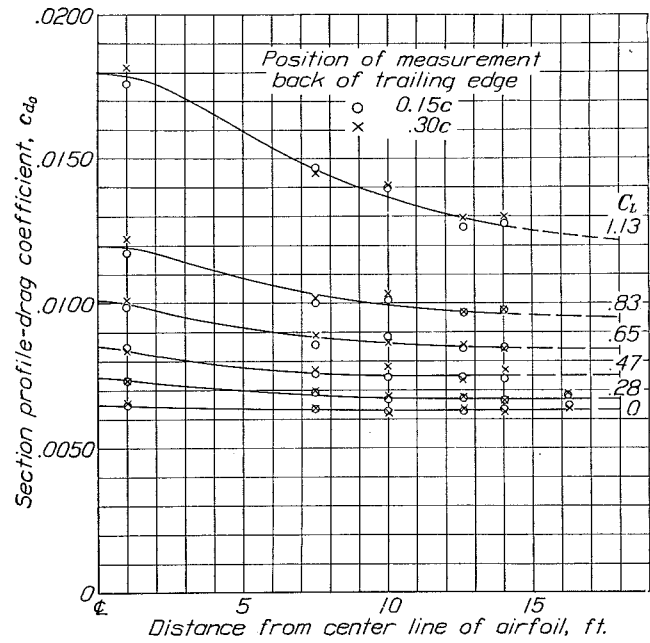

FIGURE 11.—Variation of c_{d0} across the span of the N. A. C. A. 0012 airfoil at various lift coefficients.

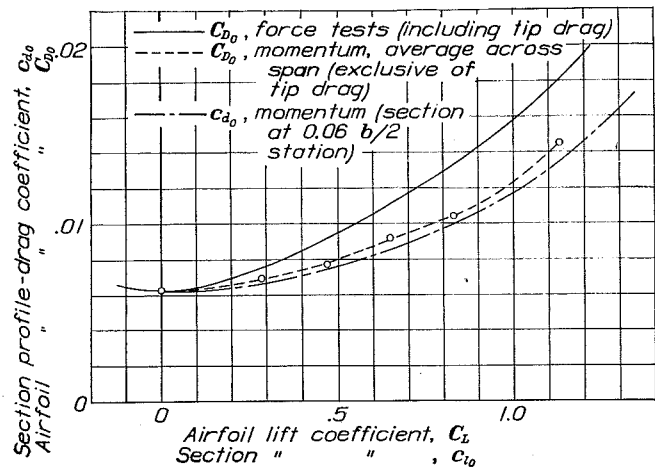

FIGURE 12.—Profile drag against lift curves obtained from momentum and force tests.

may contribute to this difference, including possible errors in the momentum method and uncertainties in computed induced drag and in the several corrections applied to the force-test results.

CONCLUSIONS

The results presented herein lead to the following conclusions with regard to the determination of profile drag by the momentum method and the application of the Betz and the Jones equations under the conditions of the present investigation:

1. The drag determined by the momentum method did not vary appreciably with distance behind the airfoil between stations ranging from $0.05c$ to $3.00c$ behind the trailing edge.

2. At zero lift, the drag determined by the momentum method agreed with that measured by force tests within 2 percent.

3. Inboard of 78 percent of the semispan, the effects of the induced-flow system of a lifting wing did not cause errors exceeding 2.5 percent at a c_l of 1.0.

4. The Betz and the Jones equations gave results that agree within 0.5 percent at stations ranging from $0.05c$ to $3.00c$ back of the trailing edge.

5. For measurements made no farther than $3.00c$ behind the trailing edge, the experimental scatter varied from 1 percent at zero lift to 3 percent at a c_l of 1.0.

LANGLEY MEMORIAL AERONAUTICAL LABORATORY,
NATIONAL ADVISORY COMMITTEE FOR AERONAUTICS,
LANGLEY FIELD, VA., December 20, 1938.

REFERENCES

1. Betz, A.: A Method for the Direct Determination of Wing-Section Drag. T. M. No. 337, N. A. C. A., 1925.
2. The Cambridge University Aeronautics Laboratory: The Measurement of Profile Drag by the Pitot-Traverse Method. R. & M. No. 1688, British A. R. C., 1936.
3. Taylor, G. I.: The Determination of Drag by the Pitot-Traverse Method. R. & M. No. 1808, British A. R. C., 1937.
4. Silverstein, Abe: Wake Characteristics and Determination of Profile Drag by the Momentum Method. Paper presented at the Fifth International Congress for Applied Mechanics, Cambridge, Mass., Sept. 12-16, 1938. (Abstract in Jour. Applied Mech., vol. 5, no. 3, Sept. 1938, p. A-129.)
5. DeFrance, Smith J.: The N. A. C. A. Full-Scale Wind Tunnel. T. R. No. 459, N. A. C. A., 1933.
6. Platt, Robert C.: Turbulence Factors of N. A. C. A. Wind Tunnels as Determined by Sphere Tests. T. R. No. 558, N. A. C. A., 1936.
7. Muttray, H.: Zuzchrift zu dem Bericht von H. Doetsch, Profilwiderstandsmessungen im grossen Windkanal der DVL. Luftfahrtforschung, Bd. 14, Lfg. 7, 20. July 1937, S. 371-372.
8. Doetsch, H.: Profilwiderstandsmessungen im grossen Windkanal der DVL. Luftfahrtforschung, Bd. 14, Lfg. 4/5, 20. April 1937, S. 173-178.
9. Glauert, H.: The Elements of Aerofoil and Airscrew Theory. Cambridge University Press, 1930, p. 149.

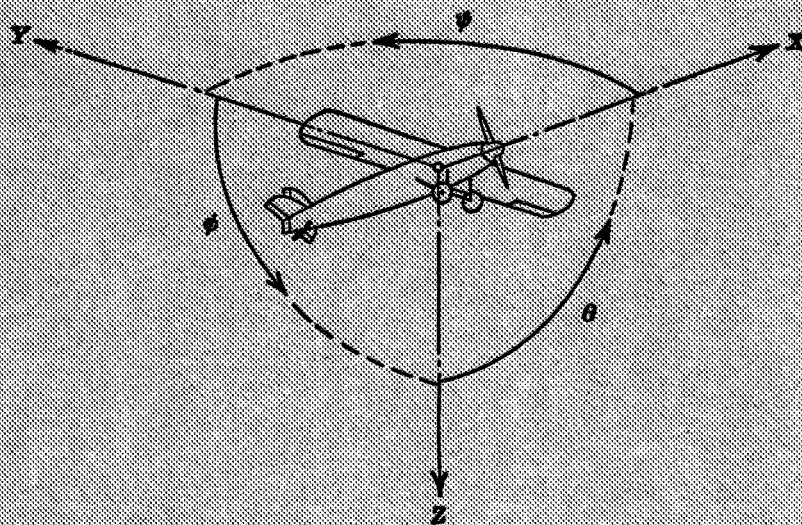

Positive directions of axes and angles (forces and moments) are shown by arrows

Axis		Force (parallel to axis) symbol	Moment about axis			Angle		Velocities	
Designation	Symbol		Designation	Symbol	Positive direction	Designation	Symbol	Linear (component along axis)	Angular
Longitudinal.....	X	X	Rolling.....	L	Y → Z	Roll.....	φ	u	p
Lateral.....	Y	Y	Pitching.....	M	Z → X	Pitch.....	θ	v	q
Normal.....	Z	Z	Yawing.....	N	X → Y	Yaw.....	ψ	w	r

Absolute coefficients of moment

$$C_l = \frac{L}{qbS}$$

(rolling)

$$C_m = \frac{M}{qcS}$$

(pitching)

$$C_n = \frac{N}{qbS}$$

(yawing)

Angle of set of control surface (relative to neutral position), δ. (Indicate surface by proper subscript.)

4. PROPELLER SYMBOLS

D , Diameter

p , Geometric pitch

p/D , Pitch ratio

V_i , Inflow velocity

V_∞ , Slipstream velocity

T , Thrust, absolute coefficient $C_T = \frac{T}{\rho n^2 D^4}$

Q , Torque, absolute coefficient $C_Q = \frac{Q}{\rho n^2 D^5}$

P , Power, absolute coefficient $C_P = \frac{P}{\rho n^3 D^5}$

C_P , Speed-power coefficient $= \sqrt[5]{\frac{\rho V_i^5}{P n^3}}$

η , Efficiency

n , Revolutions per second, r.p.s.

Φ , Effective helix angle $= \tan^{-1} \left(\frac{V_i}{2\pi r n} \right)$

5. NUMERICAL RELATIONS

1 hp. = 76.04 kg-m/s = 550 ft-lb./sec.

1 metric horsepower = 1.0132 hp.

1 m.p.h. = 0.4470 m.p.s.

1 m.p.s. = 2.2369 m.p.h.

1 lb. = 0.4536 kg.

1 kg = 2.2046 lb.

1 mi. = 1,609.35 m = 5,280 ft.

1 m = 3.2808 ft.