

Experimental Investigation of Twisted Bladed Savonius Wind Turbine Rotor

A. S. Grinspan, U. K. Saha and P. Mahanta

Department of Mechanical Engineering
Indian Institute of Technology
Guwahati-781 039
INDIA

ABSTRACT

The present investigation is aimed at exploring the feasibility of Savonius wind turbine blades for power generation, which has hitherto been limited to water pumping and grain grinding work. In this project, an attempt has been made to develop a twisted blade for its use in Savonius wind turbine rotors. The objective is to reduce the negative torque and the self-starting characteristics of a single stacked rotor system while maintaining a high rotational speed so that such a rotor system can be used for electricity generation. Tests have been carried out of semicircular (curved) and twisted blades both in a three bladed rotor system. Aerodynamic performance of these blades have been evaluated in a low speed wind tunnel on the basis of starting torque, power output and rotational speed at various setting angles and gap widths. Experimental investigation shows the potential of the twisted bladed rotor in terms of smooth running, higher coefficient of performance and self-starting capability as compared to that of the semicircular bladed rotor.

KEYWORDS: Savonius rotor, twisted blade, starting torque, coefficient of performance.

1. INTRODUCTION

The Savonius wind turbine is a vertical axis machine with high starting torque and reasonable peak power output. The use of Savonius has been restricted till now because it employs large surface area it employs [1]. From the point of aerodynamic efficiency, Savonius rotor cannot compete with high-speed propeller and the Darrieus type wind turbines [2, 3]. The rotor has low power output per given rotor size, weight and cost, thereby making it less efficient, and the coefficient of performance is of the order of 15% [4, 5]. Nevertheless, these types of turbines are simple to construct, insensitive to wind direction and self-starting [6]. Hence, it is obvious that with the increase of rotor performance characteristics, it has the potential to generate small amount of power [7-9]. Hence, it is necessary to go through the various prospects of vertical axis machines so as to improve its performance to a greater extent. From the economic point of view also, vertical axis machines for small-scale power production in rural areas of developing countries seems to be an attractive proposition.

Various types of blades like semi circular, bach type, Lebost type [10-12] etc. have been used in vertical axis wind turbines to extract energy from the air, however, no attempt has been so far made in the vertical axis wind turbine systems to reduce the negative torque and to increase the starting characteristics and efficiency with the changes in the air direction. In view of this, a distinct blade shape with a twist for the Savonius wind turbine rotor has been designed, developed and tested in the laboratory by using an exhaust fan as an air source. Preliminary investigation has demonstrated good starting characteristics of the twisted bladed rotor [13, 14].

2. OBJECTIVE

The present investigation is aimed at exploring the feasibility of Savonius wind turbine blades for power generation. At the same time, it is also important to improve the aerodynamic performance of the Savonius rotor without unduly affecting the simplicity of the rotor. In view of this, an experimental investigation has been undertaken to explore the performance of a new blade shape with a twist. This twisted blade in a three-bladed rotor system has been tested in a low speed wind tunnel with open test section facility, and its performance has been compared with a conventional semicircular blade in a three-bladed rotor system [15]. Performance analysis has been made on the basis of starting torque, rotational speed and coefficient of performance.

3. BLADE DESIGN

All the blades of the turbine rotor have been fabricated from 0.5 mm thick galvanized iron sheets. These sheet metals are commonly used in for making roofs, boxes, doors etc. because of its ability to resist corrosion and low cost. The schematic diagram of developed blades with an aspect ratio ($A_R=H/d$) of 1.83 is shown in Figure 1. The geometric parameters of the semicircular blade (Figure 2) are the blade height ($H = 220$ mm), and the blade chord ($=120$ mm). The gap width, S is varied to find the performance of the rotor in each case. The main geometric parameters of the twisted blade (Figure 3) are the blade chord ($=120$ mm), blade height ($H = 220$ mm) and the twist angle ($\alpha=10.28^\circ$). Further, the setting angle (θ), as illustrated in Figure 4, was also varied by suitable bracket length to capture the energy optimally.

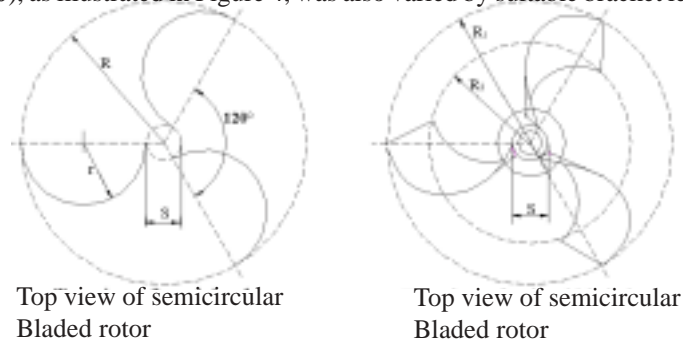

Fig. 1. Schematic diagram of developed blades

4. EXPERIMENTAL INVESTIGATION

4.1 Test Setup

To study the performance of Savonius wind turbine rotor with semicircular and twisted blades, a low speed wind tunnel with an open test section facility has been designed, developed and fabricated [15, 16]. The rotor axis is placed at a distance of 205 mm from the tunnel exit having a cross-sectional area of 375 mm x 375 mm as shown in Figure 5. All the tests have been conducted in the range of air velocity of 6-11 m/s.

4.2 Measurement Procedures

In this study, a single block dynamometer has been used to measure the starting as well as dynamic torques. The rotational speed of the rotor has been measured by means of a digital tachometer (with an accuracy of ± 1 rpm). The velocity at the exit of the tunnel has been measured by means of a

thermal anemometer (with an accuracy of ± 0.1 m/s). Prior to the conduct of tests, the tunnel has been calibrated by means of flow visualization and velocity measurement techniques [15, 16].

4.3 Data

Based on the reference velocity (U), the brake torque (T_B) and the shaft power (P_1), the performance of the twisted bladed rotor at various setting angle (θ) has been evaluated from the starting torque (T) of a single bladed system, rotational speed (N) and the coefficient of performance (C_p), and compared with the results of semicircular blades.

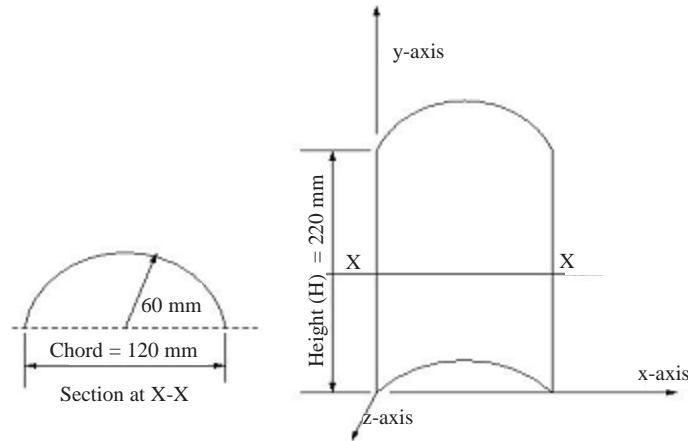

Fig. 2. Geometric details of the semicircular blade

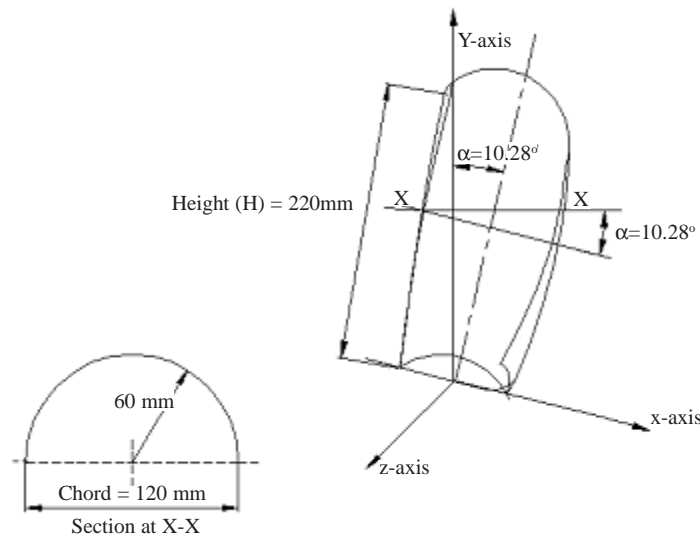

Fig. 3. Geometric details of the twisted blade

5. RESULTS AND DISCUSSION

Initially, the starting torque for a single semicircular blade and for a single twisted blade have been evaluated. As compared to the semicircular blade, the rotor of the twisted blade experiences a higher magnitude of positive torque up to 20° whereby it decreases for a short while with a rise again at

80° (Figure 6). Thereafter, it decreases and becomes zero at 140°. The rotor experiences negative torque from 140° onwards and becomes zero again at 280°, whereby it decreases and increases again. For the semicircular blade, torque characteristics shows almost similar behaviour as seen from the figure 6. In the case of the semicircular blade, the maximum force acts centrally (curvature center) and vertically; whereas for the twisted blade, the maximum force moves towards to the tip of the blade because of the twist in the blade. Due to this changes, a twisted blade gets a longer moment arm, and hence a higher value of net positive torque. Further, it has been observed that when the rotor reaches over the range 160°-280° (rotor is closer to the tunnel exit) the twisted blade has a lower negative torque than the semicircular one, because the air is being swept out of the twisted blade in the above range.

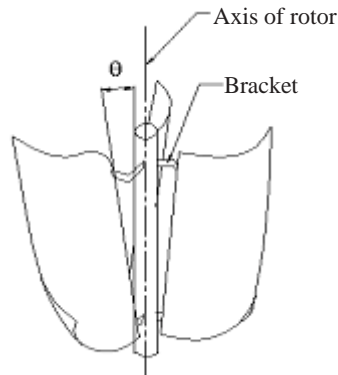

Fig. 4. Illustration of setting angle



Fig. 5. Twisted bladed rotor at the tunnel exit

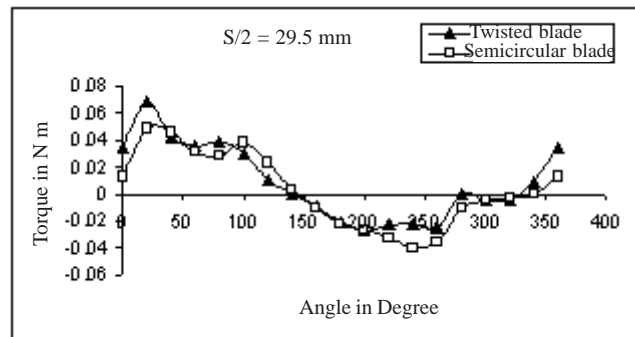

Fig. 6. Variation of the starting torque with blade orientation for a single blade at $U=10.17\text{m/s}$

The starting torque of the twisted and the semicircular blades in a three-bladed rotor system is shown in Figure 7. It is seen that the rotor of twisted blades has a marginally larger value in positive torque (as seen from the deviation towards the right side of the peaks) than that of semicircular blades because the twisted bladed rotor gives a longer moment arm.

The rotational speed (N) of the twisted bladed rotor under various setting angles at a fixed gap width ($S=30$ mm) is presented in Figure 8. The air velocity to the inlet of the three bladed rotor shaft is varied from $U=6.6$ m/s to 10.17 m/s by controlling the RPM of the tunnel fan. At $\theta=0^\circ$, the RPM increases from $N=303$ to 475 in the tested range of air velocity. It is seen that the RPM decreases with increase of setting angles and the variation is found to be similar to that of $\theta=0^\circ$. At highest setting angle, $\theta=11.32^\circ$, the RPM varies from $N=188$ to 390 in the tested range of air velocity. The decrease of RPM with increase of setting angle can be attributed to the fact that the wetted area decreases with the increase of setting angle thereby capturing less energy. As observed from Figure 8, with the increase of setting angles, the rotational speed increases sharply with increase of air velocity.

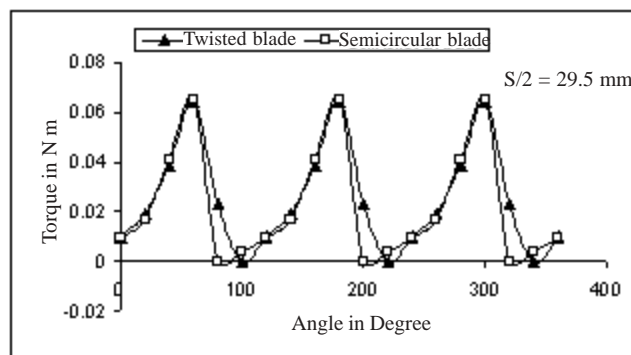

Fig. 7. Static torque of the tested blades at velocity =10.17m/s in a three bladed system

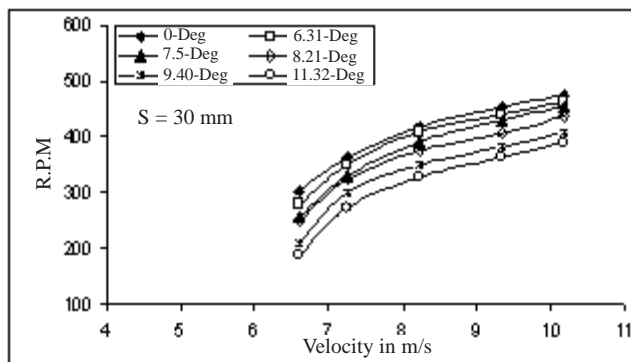

Fig. 8. RPM vs. velocity for twisted bladed rotor at various setting angle

The variation of coefficient of performance (C_p) of the twisted bladed rotor under various setting angles is shown in Figure 9. At $\theta=0^\circ$, C_p increases from 0.07 to 0.11 in the range of air velocity from $U=6.6$ m/s to 8.22 m/s and thereby it decreases. The coefficient of performance decreases with increase of setting angles, and shows a similar trend to that of $\theta=0^\circ$, i.e., initially it increases upto air velocity of $U=8.22$ m/s and then it decreases. This is because at higher value of θ , there is less energy capture due to the reduction of both negative and positive wetted area. It can be concluded that the twisted blade shows highest coefficient of performance at $\theta=0^\circ$ and at $U=8.22$ m/s.

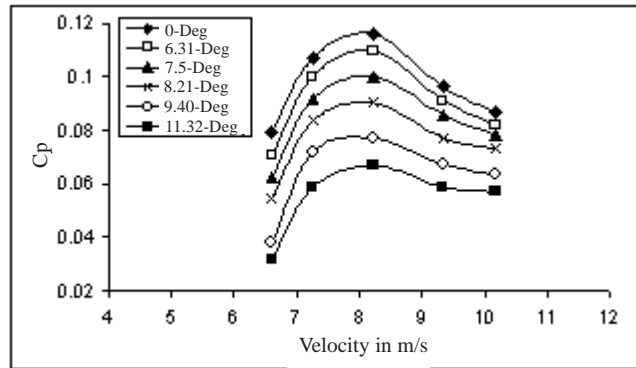

Fig. 9. Coefficient of performance vs. velocity for twisted bladed rotor at various setting angle

An attempt has been made to study the effect of gap width (S) on the performance of the rotor with twisted blades at $q = 0^\circ$ and the results are plotted in Figure 10. It is seen from the plot that the rotational speed (N) decreases with increase of gap width (S). At lowest gap width $S = 14$ mm, rotational speed varies from $N=308$ to 493 in the tested range of air velocity, while at highest gap width $S = 67$ mm, N ranges from 255 to 393 , thus showing optimum rotational performance against minimum gap

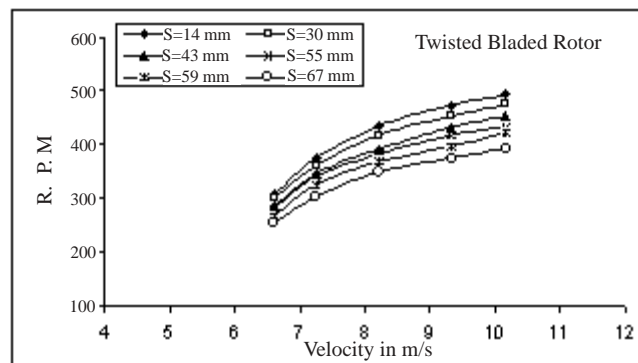

Fig. 10. Variation of RPM with velocity for twisted bladed rotor at various gap widths

width.

The effect of gap width (S) on the performance of the semicircular blade at $\theta=0^\circ$ has also been studied and the results are plotted in Figure 11. The rotational speed, N seemed to have decreased with increase of gap width (S). At lowest gap width $S= 14$ mm, rotational speed varies from $N=319$ to 505 in the tested range of air velocity, while at highest gap width $S=67$ mm, N ranges from 253 to 380 . From the data, it has been observed that at $\theta=0^\circ$, the rotational speed increases for semicircular blades as compared to twisted blades. Even though the rotational speed increases for semicircular blades, it has the lower torque as compared to twisted blades because of its lower moment arm.

The effect of gap width (S) on coefficient of performance (C_p) at $\theta=0^\circ$ in the case of twisted blade is presented in Figure 12. At $S=30$ mm, C_p increases from 0.08 to 0.11 in the tested range of air velocity $U=6.6$ m/s to 8.22 m/s, thereby it falls; while at $S=67$ mm, C_p increases from 0.065 to 0.082 in the range of air velocity $U=6.6$ m/s to 7.25 m/s, and it drops to 0.046 at $U=10.17$ m/s. This means that with the increase of gap width the peak of the C_p curve shift towards lower range of velocity thus showing its narrow operating range.

The effect of gap width (S) on C_p at $\theta=0^\circ$ in the case of semicircular blade is presented in Figure 12. At $S=30$ mm, C_p increases from 0.056 to 0.087 in the tested range of air velocity $U=6.6$ m/

s to 8.2 m/s, thereby it falls; while at $S=67$ mm, coefficient of performance C_p increases from 0.05 to 0.08 in the range of air velocity $U=6.6$ m/s to 7.25 m/s, and it drops to 0.056 at $U=10.17$ m/s. In a similar manner to that of the twisted blades, the peak of the C_p curve shift towards lower range of velocity with an increase of gap width thus showing its narrow operating range. However, the coefficient of performance is found to be lower in the semicircular blade as compared to twisted blades.

From the present experimental investigation, the following key points may be highlighted.

- The self-starting capability of the twisted bladed rotor is found to be more than the semicircular bladed rotor because, in the former case, the rotor is independent of air direction, and has a longer moment arm.
- Both the gap width (S) and the twist have significant influence on the performance of the turbine rotor.
- The twisted bladed rotor yields optimum performance when the gap width (S) varies between $S=14$ to 30 mm, while the semicircular bladed rotor yields optimum performance when the gap width varies between $S=30$ to 55 mm.

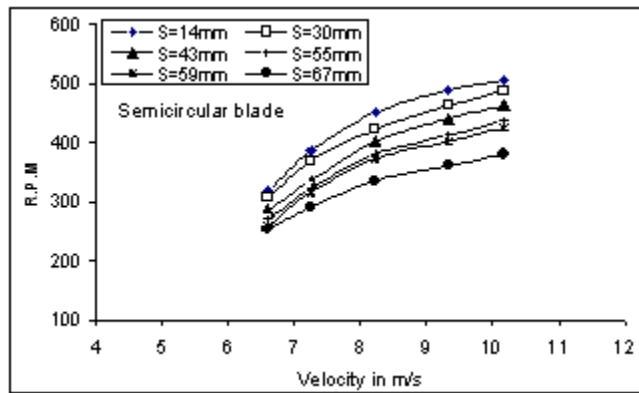

Fig. 11. Variation of RPM with velocity for semicircular bladed rotor at various gap widths

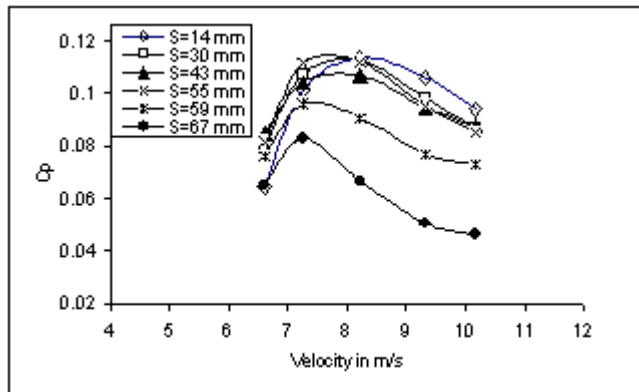

Fig. 12. Coefficient of performance vs. velocity for twisted blade at various gap widths

6. CONCLUSIONS AND RECOMMENDATIONS FOR FUTURE STUDY

In the present investigation, an attempt has been made to explore the feasibility of Savonius wind turbine for power generation. In the course of experiments with the conventional blades, a new blade shape with a twist has been developed and tested in a low speed wind tunnel. The performance

of the twisted bladed rotor has been evaluated on the basis of starting torque, rotational speed and coefficient of performance. Experimental evidence shows the potential of the twisted bladed rotor in terms of smooth running, higher coefficient of performance and self-starting capability as compared to that of the semicircular bladed rotor. The present study, however, discusses the performance of the twisted bladed rotor at a fixed twist angle of 10.28° . As wind tunnel data on twisted bladed Savonius rotor are not available in open literature, a direct comparison of the present experimental findings could not have been made. The present investigation shows the following promising areas where immediate research could be pursued in order to improve the rotor performance.

- Increase of self-starting characteristics by optimizing the twist angle of the blade
- Changing the aspect ratio to increase the energy capture capability of blade optimally
- Increase of power by installing deflection plate (augmentation) at the rotor front
- Increase of performance by inserting end plates in the blade

7. NOMENCLATURES

A	=	projected area of rotor, m^2
A_R	=	aspect ratio, H/d
C_p	=	coefficient of performance, $P_i/(1/2\rho AU^3)$
d	=	blade chord ($2r$), mm
H	=	blade height, mm
N	=	rotational speed of rotor, RPM
P_i	=	shaft power ($2\delta NT_B/60$), W

8. REFERENCES

- [1] Shankar, P. N. 1978, Development of Vertical Axis Wind Turbines, *Rural Technology*, Indian Institute of Science, Bangalore, pp. 145-162.
- [2] Modi, V. J.; and Fernando M S U K, 1989, On the Performance of the Savonius Wind Turbine, *ASME Journal of Solar Engineering*, Vol. 111, pp.71-76.
- [3] Kilmas, P. C. 1982. Darrius Rotor Aerodynamics, *Journal of Solar Energy Engineering*, Vol.104, pp.102-105.
- [4] Kumar, A.; and Grover, S. 1993. Performance Characteristics of a Savonius Rotor for Wind Power Generation-A Case Study, Alternate Sources of Energy, *Proc. of 9th National Convention of Mechanical Engineers*, IIT Kanpur.
- [5] Walker, J. F.; and Jenkins, N. 1997, *Wind Energy Technology*, John Wiley and Sons.
- [6] Ogawa, T.; Yoshida, H.; and Yokota, Y. 1989. Development of Rotational Speed Control Systems for a Savonius-Type Wind Turbine, *ASME J. of Fluids Engineering*, Vol. 111, pp.53-58.
- [7] Clark, R. N.; Nelson, V.; Barieau, R. E.; and Gilmore, E. 1981. Wind Turbines for Irrigation Pumping, *Journal of Energy*, Vol. 5, pp.104-108.
- [8] Spera, D. A. 1994. *Wind Turbine Technology*, ASME Press.
- [9] Vishwakarma, R. 1999. Savonius Rotor Wind Turbine for Water Pumping-An Alternate Energy Source for Rural Sites, *Journal of Institution of Engineers (India)*, Vol.79, pp. 32-34.
- [10] Ushiyama, I.; Nagai, H.; and Mino, M. 1982. The Optimum Design Configurations of Savonius wind Turbines, *In Proceedings of the 17th Intersociety Energy Conversion Engineering Conference*, pp. 2096-2101.
- [11] Modi, V. J.; Roth, N. J.; 1982. Prototype Design of a Wind Energy operated Irrigation System, *In the Proceedings of the 17th Intersociety Energy Conversion Engineering Conference*, pp.

- 2089-2195.
- [12] Mojola, O. O. 1985. On The Aerodynamics Design of The Savonius Windmill Rotor, Journal of Wind Energy and Industrial Aerodynamics, Vol .15, pp. 223-231.
- [13] Grinspan, A. S.; Kumar, P. S.; Saha, U. K.; Mahanta, P.; Ratnarao, D. V.; and Vedabhanu, G 2 0 0 1
Design, Development and Testing of Savonius Wind Turbine Rotor with Twisted Blades, *In the Proceedings of the 28th National Conf. on Fluid Mechanics and Fluid Power*, India, Dec.13-15, pp. 428-431.
- [14] Grinspan, A. S.; Kumar, P. S.; Saha, U. K.; and Mahanta, P. 2003. Performance of Savonius W i n d
Turbine Rotor with Twisted Bamboo Blades, In the Proceeding of the 9th Canadian Congress of Applied Mechanics, *CANCAM 2003*, June 01-06, Calgary, Alberta, Canada.
- [15] Grinspan, A. S. 2002. Development of a low speed wind tunnel and testing of Savonius wind turbine rotor with twisted blades, M. Tech. Thesis, Department of Mechanical Engineering, IIT Guwahati, India.
- [16] Grinspan, A. S.; Mahanta, P.; and Saha, U. K. 2003. Design, Development and Calibration of a Low Speed Wind Tunnel, *CD-ROM the Proceeding of the 7th Triennial International Symposium on Fluid Control, Measurement and Visualization*, FLUCOME, August 25-28, Sorrento, Italy.