

Experimental Results with two Wireless Power Transfer Systems

Alanson Sample^{1,2} and Joshua R. Smith¹

¹Intel Research Seattle, 1100 NE 45th Street, Seattle, WA 98105 ²Department of Electrical Engineering, PO Box 352500, University of Washington, Seattle, WA 98195

Abstract — This paper describes two wireless power transfer systems. The Wireless Identification and Sensing Platform (WISP) is a platform for sensing and computation that is powered and read by a commercial off-the-shelf UHF (915MHz) RFID reader. WISPs are small sensor devices that consume on the order of 2uW to 2mW, and can be operated at distances of up to several meters from the reader.

The second system harvests VHF or UHF energy from TV towers, with power available depending on range and broadcast transmit power. We report on an experiment in which 60uW is harvested at a range of about 4km.

Index Terms — Wireless Power Transfer, UHF RFID, RF Power Harvesting, Sensing

I. INTRODUCTION

This paper describes two systems that make use of RF-based wireless power transfer. The first, WISP (Wireless Identification and Sensing Platform)[1], is powered deliberately by a commercial off the shelf UHF RFID reader that transmits 4W EIRP. The second system harvests ambient VHF or UHF energy from TV towers. We describe an experiment in which we powered a commercially available thermometer/hygrometer with LCD display using only RF power harvested from a TV transmission tower.

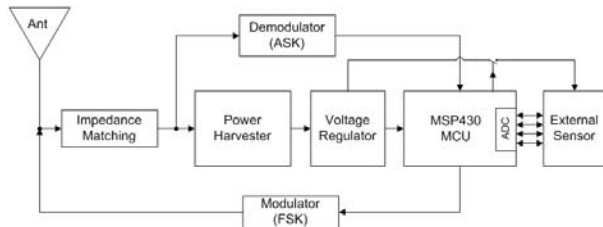

Fig. 1. Block diagram of the WISP platform.

II. WISP: WIRELESS IDENTIFICATION AND SENSING PLATFORM

A block diagram of the WISP is shown in Figure 1. The system consists of an antenna and impedance matching components, RF power harvester, demodulator to extract reader-to-WISP data, backscatter modulator for WISP-to-reader data, voltage regulator, programmable microcontroller, and optional external sensors.

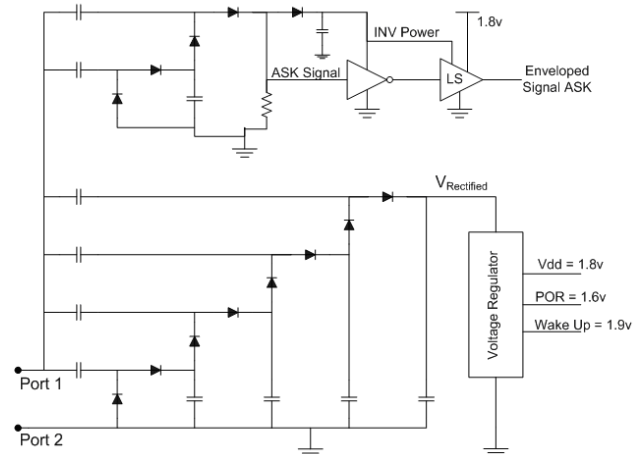

Fig. 2. Schematic of WISP power harvesting (bottom) and ASK demodulation circuit (top)

Figure 2 shows a more detailed schematic. The power harvester consists of a 4 stage charge pump. The rectified voltage is connected to a regulator and two voltage supervisory circuits. The microcontroller's nominal operating voltage is 1.8V, but it can retain the contents of RAM down to 1.6V. If the 1.6V supervisor detects a voltage less than 1.6V, it causes a hard reset of the microcontroller. When the voltage is in the range 1.6V to 1.9V, the microcontroller enters a very low power RAM retention only mode. Above 1.9V, the micro can enter active mode.

Figure 3 is a photograph of the WISP. Figure 4 shows the power harvesting and communication performance of the WISP, as a function of input power (mapped theoretically to range). The effective operating range is around 2 meters.

The WISP has been used for a variety of sensing and other applications. Sensors that have been interfaced to the WISP include light[1], accelerometer, temperature, strain gage,[2]-[3] capacitance,[4] and a custom neural amplifier[5]. Figure 5 shows example temperature data recorded by the WISP. The data collected by the WISP and reported via the RFID reader is compared with “ground truth” measurements made with a thermal multi-meter.



Fig. 3. WISP photograph. This WISP includes a 3 axis accelerometer.

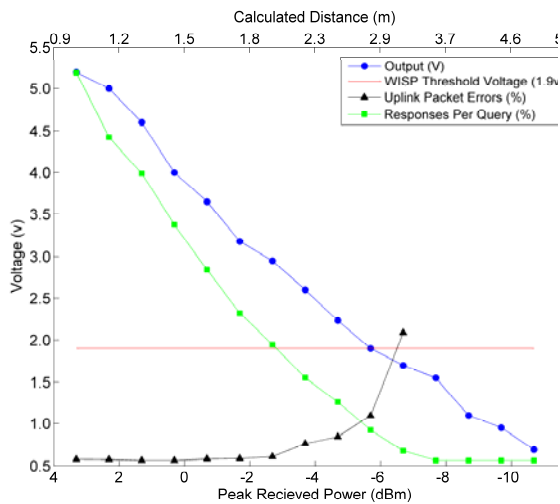

Fig. 4. WISP performance: harvested *Output Voltage*, *Uplink Packet Errors*, and *Responses Per Query* as a function of input power. The horizontal line with no markers shows the WISP operating voltage threshold of 1.9V. The line marked with diamonds shows harvested voltage. The WISP cannot operate when the harvested voltage is less than the operating threshold voltage. *Uplink packet errors* is the number of failed uplink packets divided by attempted uplink packets, expressed as a percentage. *Responses per query* is the percentage of issued reader queries that return a packet with a valid CRC.

Adding a super-capacitor to the WISP, we have created a wirelessly re-chargeable data logger that can read and log temperature data for 24 hours away from a reader, and then report back the data and recharge when it is in range of a reader.[4] The WISP has also been used for RFID and low power wireless security research.[6][7]

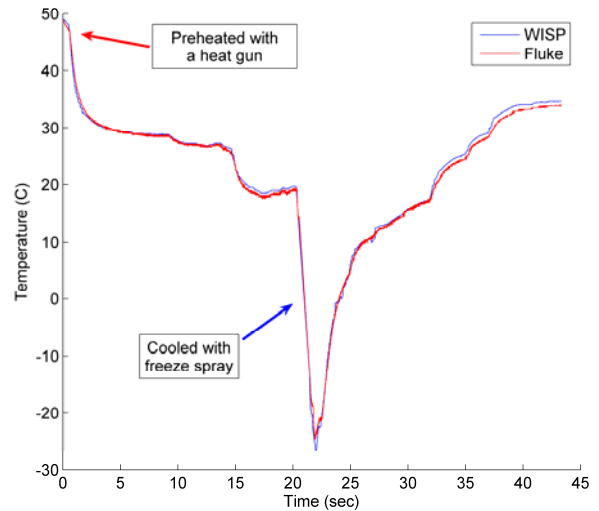

Fig. 5. Cold impulses are applied to WISP and a Fluke multimeter thermal probe and plotted over time.

III. RF HARVESTING FROM AMBIENT SOURCES

From a balcony at the Intel Research Seattle lab (47° 39' 41"N, 122° 18' 60" W), we harvested RF power from the KING-TV tower at (47° 37' 55" N, 122° 20' 59" W) which broadcasts 960kW ERP on channel 48, at 674 - 680 MHz. This is a distance of 4.1km. We used a broadband log periodic antenna (5 dBi) designed for TV applications and a 4 stage power harvesting circuit of the same design as WISP, with a front end tuned to the desired channel. The bandwidth of the tuned front end was approximately 30MHz. With the antenna manually oriented toward the transmit tower, the measured open circuit voltage was 5.0V (i.e. the only load on the power harvester was the voltmeter). Across an 8K Ohm load, we measured 0.7V, which corresponds to 60uW of power harvested. This is equivalent to the net power budget many of the WISP sensing applications.

Applying the Friis transmission formula with the parameters above yields an expected power received of 220uW. Thus the experimentally measured performance of the system is reasonably close to the theoretically expected performance.

We then connected this ambient RF harvesting system to the battery terminals of a commercially available indoor/outdoor temperature and humidity meter ("thermometer/hygrometer") with an LCD display.[8] This device is normally powered by a 1.5V AAA battery. The thermometer/hygrometer was measured to consume around 25uA at 1.5V from a laboratory power supply. About once per second, its current consumption briefly spiked up to around 50uA, presumably when sensor measurements were made.

The thermometer/hygrometer functions normally when connected to the power harvesting circuit with the antenna oriented at the appropriate transmission tower: the display contrast appears to be as good as when the system is powered by a battery. With the antenna oriented directly at the TV tower and the thermometer/hygrometer

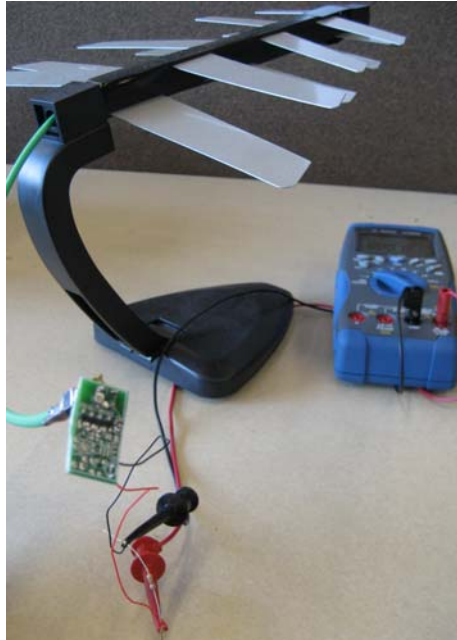

Fig. 6. Apparatus for ambient RF harvesting experiment. The power harvester is the PC board in the lower left. The harvester is fed by the log period antenna. The harvester output is connected to an 8K Ohm resistive load and a volt meter.



Fig. 7. Operating a temperature and humidity meter (including LCD display) using only ambient RF power.

connected and operational, the loaded voltage was measured to be 1.7V. As the antenna was oriented away from the tower to which it was tuned, the display contrast dropped, and then (when the antenna was further mis-oriented) appeared to stop operating altogether.

VII. CONCLUSION

The possibilities of combining the two power harvesting techniques described here are exciting. One can imagine RF powered sensor devices that log their data until they are interrogated by an RFID reader. For applications in which a suitably large, outdoor, and fixed orientation antenna can be accommodated, this should enable a perpetual sensing platform with no batteries. The only required maintenance would be periodic data download.

REFERENCES

- [1] J.R. Smith, A. Sample, P. Powledge, A. Mamishev, S. Roy, "A wirelessly powered platform for sensing and computation," Proceedings of Ubicomp 2006: 8th International Conference on Ubiquitous Computing, Orange Country, CA, USA, September 17-21 2006, pp. 495-506.
- [2] D.J. Yeager, A.P. Sample, J.R. Smith, "WISP: A Passively Powered UHF RFID Tag with Sensing and Computation," in S.A. Ahson, M. Ilyas (Eds) *RFID Handbook: Applications, Technology, Security, and Privacy*. CRC Press, Boca Raton, FL. pp. 261-278.
- [3] A.P. Sample, D.J. Yeager, P.S. Powledge, A.V. Mamishev, J.R. Smith, "Design of an RFID-Based Battery-Free Programmable Sensing Platform," IEEE Transactions on Instrumentation and Measurement, Vol. 57, No. 11, Nov. 2008, pp. 2608 – 2615.
- [4] D.J. Yeager, P.S. Powledge, R. Prasad, D. Wetherall, J.R. Smith, "Wirelessly-Charged UHF Tags for Sensor Data Collection," Proceedings of 2008 IEEE International Conference on RFID, April 16-17 2008, pp. 320-327.
- [5] J. Holleman, D. Yeager, R. Prasad, J.R. Smith, B. Otis, "Neural WISP: An Energy Harvesting Wireless Brain Interface with 1m Range," Proceedings of 2008 IEEE Biological Circuits and Systems conference (BioCAS), to appear.
- [6] H.J. Chae, D.J. Yeager, J.R. Smith, K. Fu, "Maximalist Cryptography and Computation on the WISP UHF RFID Tag," Conference on RFID Security, July 2007. <http://www.rfidsec07.etsit.uma.es/slides/papers/paper-31.pdf>
- [7] A. Czeskis, K. Koscher, J.R. Smith, T. Kohno, "RFIDs and Secret Handshakes: Defending Against Ghost-and-Leech Attacks and Unauthorized Reads with Context-Aware Communications" 15th ACM Conference on Computer and Communications Security, October 27-31, 2008.
- [8] Radio Shack Cat. No. 63-1032.