

# Experimental study of Solar Power Grass Cutter Robot

Ashish kumar chaudhari <sup>1</sup>, Yuvraj sahu <sup>2</sup>, Prabhat kumar Dwivedi <sup>3</sup>, Harsh Jain<sup>4</sup>

<sup>1</sup>Ashish kumar chaudhari, Student Mechanical Department, MATS University Raipur, Chhattisgarh, India

<sup>2</sup> Yuvraj sahu Student Mechanical Department, MATS University Raipur, Chhattisgarh, India

<sup>3</sup> Prabhat kumar Dwivedi Student Mechanical Department, MATS University Raipur, Chhattisgarh, India

<sup>4</sup> Harsh Jain Assistant Professor Mechanical Department, MATS University Raipur, Chhattisgarh, India

## ABSTRACT

Current technology commonly used for cutting the grass is by the manually handled device. In this paper used novel technology. So in this paper we are trying to make a daily purpose robot which is able to cut the grasses in Lawn. The system will have some automation work for guidance and other obstacle detection and the power source that is battery and a solar panel will be attached on the top of the robot because of this reduces the power problem.

**Keyword:-** robot lawn mower, personal robots, sensing, navigation

## 1 INTRODUCTION

The first lawn mower was invented by Edwin Budding in 1830 in Thrupp, just outside Stroud, in Gloucestershire, England. Budding's mower was designed primarily to cut the grass on sports grounds and extensive gardens, as a superior alternative to the scythe, and was granted a British patent on August 31, 1830. [1] In 1995, the first fully solar powered robotic mower became available. The mower can find its charging station via radio frequency emissions, by following a boundary wire, or by following an optional guide wire. This can eliminate wear patterns in the lawn caused by the mower only being able to follow one wire back to the station.

A robotic lawn mower is an autonomous robot used to cut lawn grass. A typical robotic lawn mower requires the user to set up a border wire around the lawn that defines the area to be mowed. The robot uses this wire to locate the boundary of the area to be trimmed and in some cases to locate a recharging dock. Robotic mowers are capable of maintaining up to 20,000 m<sup>2</sup> (220,000 sq ft) of grass.

Robotic lawn mowers are increasingly sophisticated, are self-docking and some contain rain sensors if necessary, nearly eliminating human interaction. Robotic lawn mowers represented the second largest category of domestic robots used by the end of 200

## Solar Grass Cutter

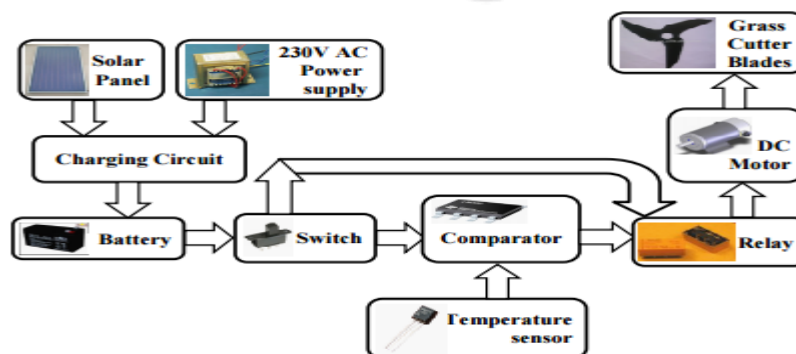

Figure- 1. Image of Block Diagram of model

Possibly the first commercial robotic lawn mower was the MowBot, introduced and patented in 1969 and already showing many features of today's most popular products.

In 2012, the growth of robotic lawn mower sales was 15 times that of the traditional styles. With the emergence of smart phones some robotic mowers have integrated features within custom apps to adjust settings or scheduled mowing times and frequency, as well as manually control the mower with a digital joystick

## 2. LITERATURE REVIEW

Some of the available products will be described in this Section. More complete information may be obtained from the manufacturers listed in the references.

### 2.1 Husqvarna

Husqvarna [2], a Swedish manufacturer, this year is also introducing its Automatic Mower to the U.S. market (it's been sold in Europe for about three years). It works much the same as the Robomow with a boundary wire implanted at the border of your lawn. The Husqvarna model, however, takes care of itself. Whereas the Robomow has to be taken out and set up and watched by the owner, the Husqvarna Automatic Mower lives outside, mows when it's programmed to mow and automatically returns to its base for recharging. The Husqvarna model is also significantly lighter than the Robomow (15 pounds vs. the Robomow's 42 pounds). According to Husqvarna, this not only makes it safer, but it leaves no tracks on the lawn. This complete freedom from even the thought of mowing, however, does have its price -- \$1,995 plus \$200 to \$300 for installation. It's available in limited quantities this year from select dealers. The company also plans next year to release a solar-powered model to the U.S. market. Husqvarna Auto Mower and Solar Mower work independently. A boundary loop wire holds the lawn mower to the lawn and a search loop ensures that it returns to the docking station for battery recharging. The solar Powered version does not need a charging station and will be in production next year. Both mowers share similar features, the only difference is the power source. Almost silent and environmentally friendly. The boundary loop wire (red) defines the Auto Mower's cutting area whilst the search loop wire (yellow) directs the mower to the charging station. The boundary loop is also laid out around trees and surfaces of the lawn which will not be cut. The lawn mower changes direction if it touches garden furniture, a tree or other solid objects, yet is able to cut under bushes and hedgerows. You can program the cutting height between 30 and 95 mm to achieve a lawn just the way you want it. Dimensions: (L) 71 cm, (W) 60 cm, (H) 26 cm

**2. 2 SN Eno** [2]A robot that operates on an on-board, solar charged battery has been designed by the French manufacturer SN Eno. The Robo-Mower<sup>4</sup> the capability of steering itself across a person's lawn . This robot called the Atawa A34, uses built-in infrared sensors to avoid obstacles. This system uses wires buried beneath the surface of the ground to control it. It operates at a top speed of 21 ft/min. Robo-mower is a 12.5-pound solar-powered robotic lawn mower that cruise the yard continuously and silently, using an on-board computer and sensor to guide the device while it cuts the grass. Poulan Weed-Eater and its parent company A.B. Electrolux of Sweden, plan full production next year. (St. Petersburg Times 3/12/94 A17)

**2.3 Technical Solutions** [3] Another example is called the Lawn Ranger described by Rafaels and developed by Technical Solutions of Frederick, Md. The design uses an onboard computer to control the mower and interact with sensors that guide the robot. The robot has two modes – operation :remote mode in which an individual guides the mower around the outer perimeter of a person's yard and around any obstacles in its path. The system is switched to automatic mode in which the robot's infrared sensors make a comparison between cut and uncut grass. The mower continues this process until it completes the job. The inventor was seeking to manufacture the prototype at a cost of \$900 with the intension of creating larger models for the future.

**2.4 Weed Eater** [2] Another example of an autonomous lawn cutting system is called the "Weed Eater" developed by the Weed Eater Corporation<sup>6</sup>. The system is a solar powered emission free mower that harnesses enough power to operate itself. The robot is equipped with 34 iridescent solar cells imbedded on top of the system's platform and has the capability of handling properties up to 13,500 sq-ft. The system operates on the same principle as the Lawn

Ranger except it uses a cable beneath the surface of a person's lawn. The mower uses this wire along with its sensors to allow the robot to maneuver around while keeping the system on track. The mower will continue to operate as long as the mower has energy, from the sun. The robot is equipped with a flexible bumper that when activated backs the mower up and continues the robot on a different path. The system has an on-board memory system which remembers all of the previous cutting paths and identifies what grass has not been cut. The unit weighs about (12.5lbs) and its safety precautions are much more precise than most mowers. It has the advantage of cutting grass in the form of a mulch so that the use of a grass catcher or raking is not required.

### 3. PATENTS

A preliminary patent search was conducted and brief summaries are given in this section. Please refer to the original patents for exact wording and ideas.

The most recent patent found was by Nelson[4] This automated, self propelled lawn mower uses a rotating directional loop antenna to determine its position within the cutting area by measuring the angle between transmitters placed in a known configuration beyond the cutting area, and by calculating the solution of simultaneous circle equations defined by that configuration. Orientation is determined by comparing present and previous positions. Stored path information is compared with the calculated position to determine steering signals which direct the mower to move directly toward the next point in the desired path. When the mower reaches that point the next coordinates are retrieved from memory and the process is repeated similarly for all successive points in the path.

Next is a remote controlled guidance system invented by Zondle[5]. A remote control method of guidance for a work vehicle including a handheld control unit, an antenna/transponder placed on the periphery of the worksite, a controlling unit on the work vehicle itself. The control unit compares timing signals to subsequently control of the speed of independently powered wheels. There is a manual and automatic mode of control for the vehicle. The vehicle is positioned at a starting point by the user, and upon activation of the automatic mode, a timing pulse, either ultrasonic or electromagnetic is issued from the control unit on the vehicle. When the pulse is sensed by the transponder on the antenna, a responding pulse is transmitted. This is, in turn, received by the vehicle and thus a base time is set for the interval between the transmission of the pulse and the return signal from the transponder, the interval being indicative of the distance between them. The vehicle moves forward while continuing at intervals to send the pulse and if the secondary timing interval is larger than the base interval, the inner wheel is slowed to bring the vehicle closer. If the interval is shorter, the inner wheel is speeded up to move the vehicle away from the transponder. Thus, the vehicle describes a smooth arc about the transponder until the user sends another signal to the device, indicating that the device is to move a preset distance further away from the transponder, reset the base interval, and continue.

### 4. PROBLEM IDENTIFICATION

- There are lots of labor charge needed for a simple grass cutting work. The electric and labor charge both cost gives a heavy expense. The human body depends on atmosphere and weather conditions.
- Earlier most of the activities are done by manually. Gradually so many big and small equipment's are developed to ease human activities, thus to reduce the human efforts to do the things.
- Now a day's most of the activities which included human efforts are either replaced or automated by the use of machines or other kinds of equipment. Skilled persons are required for conventional grass cutter .why because here we uses animals like bulls .now a days the technology is developed in other hands skilled persons with convention grass cutter were decreased.
- Now we have a need to depend on the technology. Due to the risk involved in a conventional grass cutter, now days very few peoples coming forward to grass cutting by conventional grass cutter .moreover, educational background of Indian youth is improving. So most of people hesitate to use conventional grass cutter.

### 5. Methodology

The methodology for this project is similar to the prototype analysis process. In this project we are fabricating a prototype of the sola powered grass cutter. The methodologies of these attachments are explained in few sub-headings.

### 5.1. Components of attachment

### 5.2. Working of solar grass cutter

The methodology is explained in four parts. System parts are given with their specification and dimension. Modeling will have a simple layout type diagram in thesis. In this diagram the parts are explained by their major dimensions only. Working has just functional details in paragraphs. The delayed or incomplete portion of fabrication is not explained. These portions are explained by topic “improvements and modification”.

#### 5.1. Component of attachment

The main components of the solar powered grass cutter are,

1. Solar panels
2. Batteries
3. DC motor
4. Solar charger
5. Mechanism used
6. Circuitry
7. Blades

#### 5.1.1. SOLAR PANEL:

##### Photovoltaic principles:

The photo-voltaic effect can be observed in nature in a variety of materials that have shown that the best performance in sunlight is the semiconductors as stated above. When photons from the sun are absorbed in a semiconductor, that create free electrons with higher energies than the created there must be an electric field to induce these higher energy electrons to flow out of the semi-conductor to do useful work. A junction of materials, which have different electrical properties, provides the electric field in most solar cells for the photon interaction in a semiconductor. A solar cell consists of

1. Semi –conductor in which electron hole pairs are created by the absorption of incident solar radiation.
2. Region containing a drift field for charge separation.
3. Charge collecting front and back electrodes.

##### Photovoltaic effect

The photo-voltaic effect can be described easily for p-n junction in a semi-conductor. In an intrinsic semi-conductor such as silicon, each one of the four valence electrons of the material atom is tied in a chemical bond, and there are no free electrons at absolute zero. If a piece of such a material is doped on one side by a five valence electron material, such as arsenic or phosphorus, there will be an excess of electrons in that side, becoming an n-type semi-conductor.

The excess electrons will be practically free to move in the semi-conductor lattice. When a three valence electron material, such as boron dopes the other side of the same piece, there will be deficiency of electrons leading to a p-type semi-conductor. This deficiency is expressed in terms of excess of holes free to move in the lattice. Such a piece of semi-conductor with one side of the p-type and the other, of the n-type is called p-n junction. In this junction after the photons are absorbed, the free electrons of the n-side will tend to flow to the p-side, and the holes of the p-side will tend to flow to the n-region to compensate for their respective deficiencies. This diffusion will create an electric field from the n-region to the p-region. This field will increase until it reaches equilibrium for voltage, the sum of the diffusion potentials for holes and electrons. If electrical contacts are connected through an external electrical conductor, the free electrons will flow from the n-type material through the conductor to the p-type material as shown in the figure. Here the free electrons will enter the holes and become bound electrons thus both free electrons and holes will be removed. The flow of electrons through the external conductor constitutes an electric current, which will continue as long as free electrons and holes are being formed by the solar radiation. This is the basis of photo-voltaic conversion that is the conversion of solar energy into electrical energy. The combination of n-type and p-type semiconductors thus constitutes a photo-voltaic cell or solar cell. All such cells some rate direct current that can be converted into alternating current if desired. The photo-voltaic effect can be observed in almost any junction of material that have different electrical characteristics, but the best performance to date has been from cells using semiconductor material especially all of the solar cells used for both space and terrestrial applications have been made of the semiconductor silicon. Future cells may use such materials as the

semiconductors like Gallium arsenate, copper sulphate cad sulphide etc. The device used to utilize the photovoltaic effect is solar cell.

### 5.1.2 BATTERY:

The batteries are used as a storage device for solar energy which can be further converted into electrical energy. The only exceptions are isolated sunshine load such as irrigation pumps or drinking water supplies for storage, for small units with output less than one kilowatt. Batteries seem to be the only technically and economically available storage means. Since both the photo-voltaic system and batteries are high in capital costs, it is necessary that the overall system be optimized with respect to available energy and local demand pattern. To be economically attractive the storage of solar electricity requires a battery with following particular combination of properties:

- 1.Low cost
2. Long life
- 3 .High reliability
4. High overall efficiency

### 5.1.3 Solar charger

The power charge regulator is also known as charge controller, voltage regulator, charge-discharge controller or charge-discharge and load controller. The regulator sits between the array of panels, the batteries, and the equipment or loads.

By monitoring the voltage of battery, the regulator prevents overcharging or over discharging. Regulators used in solar applications should be connected in series: they disconnect the array of panels from the battery to avoid overcharging, and they disconnect the battery from the load to avoid over discharging. The connection and disconnection is done by means of switches which can be of two types: electromechanical (relays) or solid state (bipolar transistor).

Solar chargers should never be connected in parallel. In order to protect the battery from gasification, the switch opens the charging circuit when the voltage in the battery reaches its high voltage disconnects (HVD) or cut-off set point. The low voltage disconnects (LVD) prevents the battery from over discharging by disconnecting the load. The most modern regulators are also able to automatically disconnect the panels during the night to avoid discharging of the battery. They can also periodically overcharge the battery to improve their life, and they may use a mechanism known as pulse width modulation (PWM). Solar charger has three light indicators. The first light blinks when the batteries are charging by using solar energy. The second light glows when the charging in the batteries is very low. The third light glows when the batteries are fully charged and an extra load (charging) is applied on the batteries.

### 5.1.4 Mechanism used:

In this project we are using a rotary cutter blade. A rotary mower rotates about a vertical axis with the blade spinning at high speed relying on impact to cut the grass. This tends to result in a rougher cut and bruises and shreds the grass leaf resulting in discoloration of the leaf ends as the shredded portion dies. This is particularly prevalent if the blades become clogged or blunt. Most rotary mowers need to be set a little higher than cylinder equivalents to avoid scalping and gouging of slightly uneven lawns, although some modern rotaries are fitted with a rear roller to provide a more formal striped cut. These machines will also tend to cut lower (13 mm) than a standard four-wheeled rotary.

### 5.1.5 Circuitry

The circuitry part we are using is a motor driver circuit. The diagram is given below.

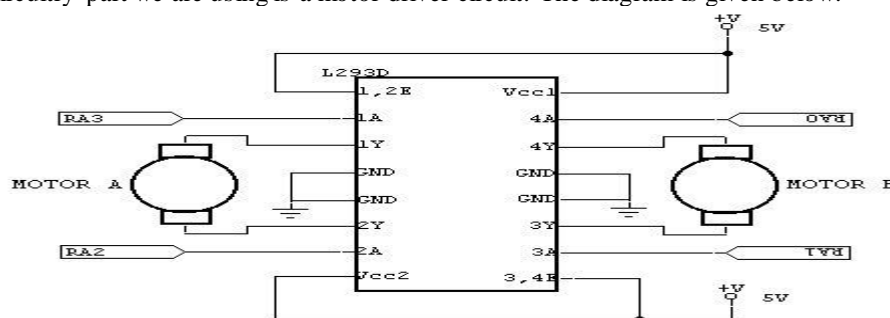

Figure- 2 Motor driver circuit



## 6. WORKING OF SOLAR POWERED GRASS CUTTER

- Coming to the working of solar powered grass cutter, it has panels mounted in a particular arrangement at an angle of 45 degrees in such a way that it can receive solar radiation with high intensity easily from the sun.
- These solar panels convert solar energy into electrical energy as studied earlier. Now this electrical energy is stored in batteries by using a solar charger.
- The main function of the solar charger is to increase the current from the panels while batteries are charging, it also disconnects the solar panels from the batteries when they are fully charged and also connects to the panels when the charging in batteries is low.
- The motor is connected to the batteries through connecting wires .Between these a two motor driver is provided. It starts and stops the working of the motor.
- From this motor, the power transmits to the mechanism and this makes the blade to rotate with high speed and this makes to cut the grass.
- 

## 7. CONCLUSION:

In the presented paper provides the fabricated information about the “Fabrication of Solar grass Cutting Machine” which was designed such that the solar plate generates solar energy and utilizing this energy for running the grass cutter motor. Integrating features of all the hardware components used have been developed in it. Presence of every module has been reasoned out and placed carefully, thus contributing to the best working of the unit. Secondly, using highly advanced IC’s with the help of growing technology, the project has been successfully implemented. Thus the project has been successfully designed and tested. The idea can be extended by adding more features like displaying the solar voltage generated on LCD display unit, also alerting when the battery voltage level goes low below threshold limit. We can add an interfacing of automatic power bank to charge the battery instantly. It can also be extended using driver circuits for controlling intensities, speed levels of the motor. Extensions using Wireless remote controls like RF, zigbee, Wi-Fi networks through which the grass cutter.

This lawn mower will meet the challenge of environmental production and low cost of operation since there is no cost for fueling. A lawn mower has been developed for the use of residences and establishments that have lawns where tractor driven mowers could not be used.

## 8. REFERENCES:-

- [1] US RE 8560, Passmore, Everett G., "Improvement in Lawn-Mowers", published 23 February 1869, issued 28 January 1879; see pg 1, col 2. For a copy, see Google Patents copy. This source indicates the patent number as "6,080". According to "British patent numbers 1617 - 1852 (old series)", the patent number would have been assigned sometime after 1852 and taken the form of "6080/1830".
- [2] Ernest L. Hall. A Survey of Robot Lawn Mowers, Available from: Ernest L. Hall Retrieved on: 06 October 2015
- [3] Technical Solutions, J. Hammond and R. Rafaels, “Build the Lawn Ranger,” Radio Electronics, June 1990, pp. 31-49.
- [4] Robert Zondlo, U.S. Patent 5,461,292, Remote controlled guidance system for working vehicle ,October 24, 1995.
- [5] Andre Colens, U.S. Patent 5,444,965, Continuous and autonomous mowing system, August 29, 1995.