

Experiments with High Velocity Positive Ions.—(I) Further Developments in the method of obtaining High Velocity Positive Ions.

By J. D. COCKCROFT, Ph.D., Fellow of St. John's College, Cambridge, and
E. T. S. WALTON, Ph.D.

(Communicated by Lord Rutherford, O.M., F.R.S.—Received February 23, 1932.)

[PLATE 11.]

Introduction.

In a previous communication* we described the development of a method of obtaining positive ions of hydrogen with energies up to 300 kilovolts. A system of rectifiers was built which allowed steady potentials of this order to be obtained, and the methods necessary for the acceleration of positive ions from a hydrogen discharge tube were worked out.

With this apparatus, investigations were made to determine whether any X-radiations or γ -radiations of appreciable intensity were produced by the impact of protons and molecular ions of hydrogen on matter. It was found, when all secondary effects were excluded, that if any such radiation is produced its intensity was comparable with the limits of error of the experiment, and was certainly not greater in intensity than one-millionth of the intensity of the continuous X-radiation which would have been produced by an equal electron source of the same energy. Since the intensity of any radiation would be expected to increase rapidly with the energy of the ions it became apparent that to obtain results of interest it would be necessary to extend the field of the work to higher voltages. The method used in the present experiments is an extension of that described in the previous paper. A source of high voltage has been developed, using thermionic rectifiers and condensers, which is capable of producing 800,000 volts steady potential. This potential is applied to an experimental tube down the axis of which protons from a hydrogen canal ray tube are accelerated. The protons can be transmitted through a mica window into an experimental chamber. Up to the present we have been able to produce and carry out experiments with protons having energies up to 710 kilovolts, and there seems no reason to doubt that the method will allow of this range being extended considerably.

* 'Proc. Roy. Soc.,' A, vol. 129, p. 477 (1930).

The Method of Generating the High Potential.

In the previous paper we gave reasons why we considered it advantageous to work with steady potentials rather than with impulse voltages, Tesla coil voltages or alternating currents. Our experiments at the lower voltages confirmed this view, and we therefore decided to construct a system of rectifiers which would enable a steady potential of 800 KV. to be obtained.

In order to be able to carry out this plan at a reasonable cost, and within the limits of ordinary laboratory accommodation, it became evident that it would be very necessary to use some form of voltage multiplying circuit.

The general principle underlying the method adopted is illustrated by fig. 1.

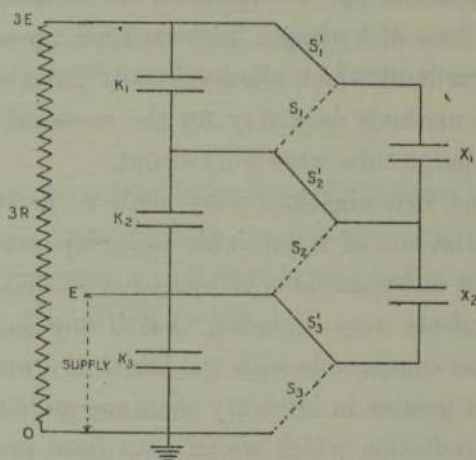

FIG. 1.

Three condensers, K_1 , K_2 and K_3 , each of capacity C , are connected in series and condenser K_3 is connected to a source of steady potential E . If now two other condensers, X_1 , X_2 , are connected to condensers K_1 , K_2 , K_3 , first as shown by the dotted lines S_1 , S_2 , S_3 , and then as shown by the full lines S_1' , S_2' , S_3' , then in the first cycle when X_1 and X_2 are connected to K_2 and K_3 , condenser X_2 will be charged to voltage E . When the switches are moved over to the upper position, condenser X_2 will share its charge with condenser K_2 and both will be charged to $E/2$ if they have equal capacity. In the next reversal of the switches, condensers K_2 and X_1 will be connected and take up potentials $E/4$ whilst condenser X_2 will be recharged to potential E . It is thus evident that charge will gradually be transferred to all the condensers until, in the absence of loss, a potential $3E$ will be developed across the condensers K_1 , K_2 , K_3 in series.

The principle is evidently capable of extension, and by adding more condensers any multiple of a given steady voltage may be obtained. It is further clear that the principle is reversible and that if the terminals $3E$ and O are connected to a source of potential $3E$, then current may be drawn off at potential E between the terminals E and O .

Various methods of carrying out the switching process other than mechanical means can be devised. Two of the switches may be replaced by controlled grid triodes and the remainder by diodes.

Thus in fig. 2, switches S_3 and S_3' of fig. 1 are replaced by two triodes or thyratrons T_1 and T_2 , whose grid potentials are varied cyclically and in opposite phase so that they conduct in alternate half cycles. Switches S_1 and S_1' , S_2 and S_2' , are replaced by diodes D_1, D_1', D_2, D_2' . Now, when valve T_2 is conducting, if E has a positive potential the condenser X_2 is charged through diode D_2 and triode T_2 to potential E .

Thus when valve T_1 becomes conducting, the potential of t_3 will rise to the potential E and the potential of t_2 will rise to a potential $2E$, and condenser X_2 will therefore charge condenser K_2 through diode D_2' and triode T_1 . It is further clear that in successive cycles when T_1 is conducting, condenser X_1 will charge condenser K_1 through diode D_1' , and will be charged through diode D_1 when T_2 is conducting. Thus we have exactly the same process as in the switching circuit of fig. 1.

The difficulty in applying this method to obtain potentials of the order of 800 KV. lies in the development of triodes which will stand potentials of the order of 200-400 KV. Fortunately, however, it is possible to perform the same operations when relatively small outputs are required, by more simple means.

It has been shown that the triodes operate by causing the potential of t_3 to assume alternately the potentials of p_3 and p_4 . If now we replace triodes T_1 and T_2 by diodes D_3 and D_3' , and connect the high tension winding of a transformer giving a potential $E/2$ in series with a condenser across the diode D_3' , then power will be delivered from the transformer and condenser X_3 is charged through diode D_3' to potential $E/2$ at the negative peak of the transformer wave. The potential of t_3 will therefore alternate between zero and E . Now when t_3 approaches potential E , con-

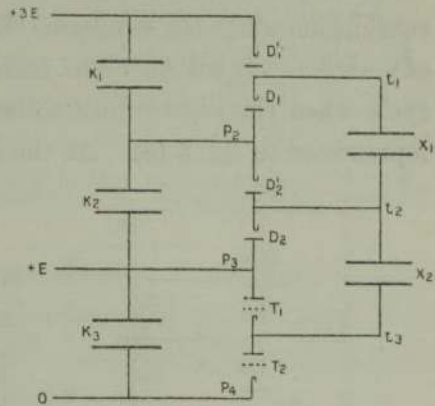

FIG. 2.

denser K_3 will be charged through diode D_3 instead of receiving power from a D.C. source as in the previous circuit. As the potential of t_3 falls again, the potential of t_2 falls below the potential of p_3 and hence condenser X_2 is charged through diode D_2' exactly as in the earlier circuit. Thus an equilibrium state is reached when each of condensers K_1, K_2, K_3, X_1 and X_2 is charged approximately to voltage E .

If now a load of resistance $3R$ is connected across the system, then in the equilibrium state the condenser K_1 will lose charge $Q = E\tau/R$ during a cycle of period τ . It will therefore receive charge Q over a small fraction of the half cycle when the transformer voltage is a maximum. The charging period is represented in fig. 3 (a). At the same time, condenser K_2 receives charge $2Q$

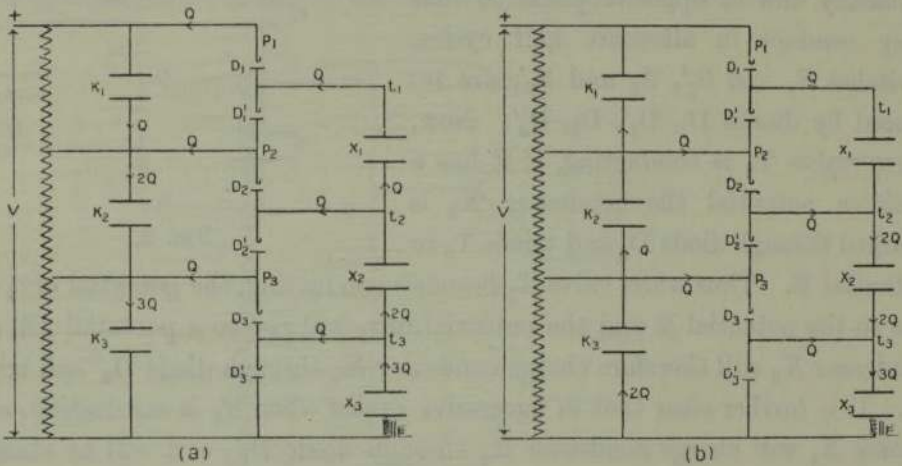

FIG. 3.

to replenish the charge lost to the load in the cycle and the charge transferred to X_1 in the transfer half cycle. Condenser K_3 will at the same time receive charge $3Q$ making up charge Q lost in the load and charge $2Q$ lost in the transfer cycle. The transformer will at the same time supply power $3Q \cdot E/2$.

The transfer half cycle is illustrated by fig. 3 (b). When the transformer potential is near the negative peak value, diodes D_1', D_2', D_3' become conducting; condenser K_2 transfers to condenser X_1 the charge lost to K_1 in the previous transfer, condenser K_3 transfers charge $2Q$ and the transformer passes charge $3Q$.

Thus for an n stage circuit ($2n$ voltage multiplication) the total voltage fluctuation across the load will be given by the voltage charge during the charging period,

$$\delta V = \frac{Q}{C} + \frac{2Q}{C} + \dots + \frac{nQ}{C} = \frac{n \cdot n + 1}{2} \cdot \frac{E\tau}{CR}.$$

Thus the percentage voltage fluctuation will be

$$\frac{\delta V}{V} = \frac{n+1}{2} \frac{\tau}{CR} \quad (1)$$

Thus if $n = 2$, $R = 10^9$, $C = 0.001 \mu\text{F}$ and $\tau = 10^{-2}$ seconds, the percentage fluctuation will be 1.5 corresponding to a load current of 0.4 milliamps. at 800 KV. We have assumed, of course, that the filament emission does not limit the transference of charge. The emission has to be adequate to transfer the charge during a small fraction of a cycle. Should this not be the case, then the full theoretical voltage multiplication will not be obtained. The absolute value of the ripple will be unaltered, but its value as a percentage of the mean output voltage will be increased. To obtain a fluctuation of less than 2 per cent. with full voltage multiplication, the emission must be at least 30 times the load current.

The efficiency of the system will clearly depend on the voltage characteristics of the diodes, and on the voltage difference across the valves when they become conducting. It may be shown that if space charge be neglected the efficiency of transfer is of the order of $1 - \delta V/V$.

The amount of power which can be transformed by the system depends on the size of the condensers used and can never be great by reason of the low switching frequency attainable. If a transformation system is required for large powers it will be necessary to use the method of fig. 2 where the switching frequency could be made very high and a square wave form used. It is also interesting to note that this system could be reversed by interchanging triodes T_1, T_2 with diodes D_1, D_1' . It would be possible therefore by some such arrangement to transform D.C. power from a high voltage to a low voltage should this be required.

For our work, however, where the load current is determined solely by corona loss and is of the order of milliamperes, the circuit of fig. 3 has the great advantage of simplicity. Each rectifier and condenser has to stand twice the voltage of the transformer and the number of stages is therefore determined by the maximum voltage for which rectifiers can be constructed. From our previous experience it appeared probable that rectifiers could be built to stand a voltage of 400 KV. without difficulty. We therefore decided to use a double stage circuit giving fourfold voltage multiplication, using four rectifiers and four condensers.

The circuit finally adopted, differs in the arrangement of condensers from a circuit suggested by Schenkel,* which also allowed voltage multiplication to

* 'Elektrotech Z.,' vol. 40, p. 333 (1919).

any extent, but required some of the condensers used to withstand the full voltage of the output circuit.

The Rectifiers.

In our previous rectifiers we used 12-inch diameter glass bulbs with an overall length of 36 inches and stem diameters of 2 inches and 3 inches respectively. Our experience with these rectifiers showed that when a voltage greater than 300 KV. was applied they tended to puncture near the neck of the bulb on the side of the smaller diameter stem, this being the positive side. Experiments were therefore carried out which showed that it was possible to eliminate this trouble by using, instead of bulbs, cylinders of approximately 14 inch diameter and length 3 feet.

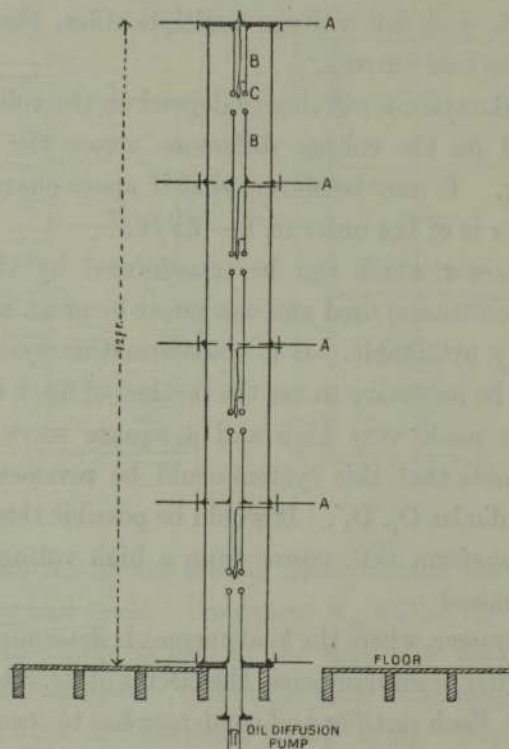
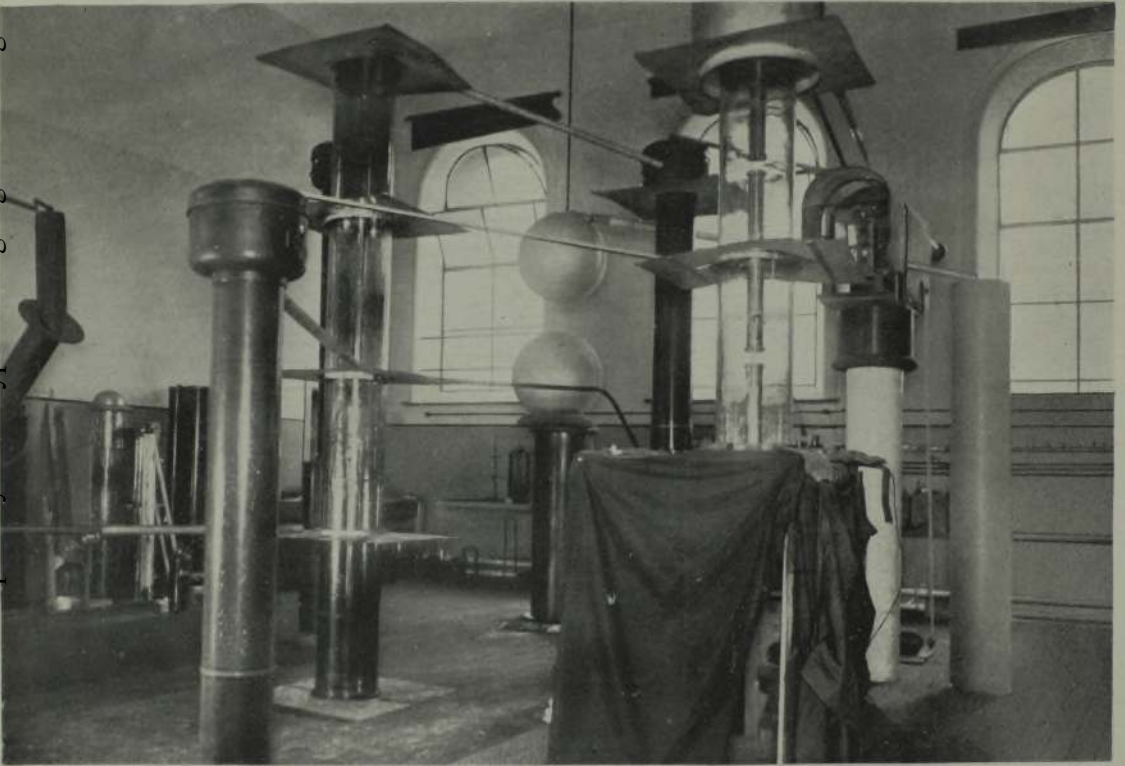

FIG. 4.

We therefore decided on the rectifier system illustrated in fig. 4. Four glass cylinders of these dimensions were erected in the form of a tower, and pieces of tinned sheet iron, A, 3 feet square, were placed between adjacent cylinders. The electrodes, B, were attached to these and they also served the purpose of giving a fairly uniform potential gradient down the length of the cylinders. The top and bottom of the tower were closed by thick metal plates. All the joints were made airtight by means of "plasticene" placed on the outside.



When this is worked in tightly with the fingers, quite a good vacuum can be obtained. The surface is then rubbed over with tap grease to seal up any minute holes such as might occur along the surface between the glass or metal and the plasticene. This method of making joints has been found to be very reliable. The ease with which the joint may be made and broken again make it a very convenient type of vacuum joint. The two surfaces to be joined require only a very rough preparation. Thus a good joint between a flat plate and a 3-inch brass tube can easily be made even if the end of the latter has merely been sawn off roughly with a hacksaw and considerable gaps have to be bridged by the plasticene. In some preliminary experiments on the large glass cylinders, ordinary commercial plasticene was employed and found to be quite satisfactory. In the final tower of rectifiers, a special putty like sealing compound was used, which had been made from low vapour pressure products.*

The electrodes were made from thin walled steel tube and the ends were fitted with thick rings, C, made from $\frac{3}{4}$ -inch diameter steel to prevent auto-electronic emission. Before insertion in the apparatus, these rings were out-gassed in a vacuum furnace. Each filament consisted of about 3 cm. of 0.25 mm. tungsten wire bent to the form of a V and supported in the middle as well as at the ends. They projected slightly beyond the ends of the steel electrodes. One end of each filament was connected to one of the tinned sheets and the lead to the other end was brought out of the apparatus through a small hole drilled near the end of each cylinder. These holes were then sealed up with plasticene. The filaments were heated from 6-volt accumulators which were kept in rounded metal boxes, these being placed on the tops of the various condensers. The rectifiers were evacuated by a three-stage oil diffusion pump of the type described in the previous paper and this was backed by a *hyvac*. In order to save head room, the pumps were placed under the floor and they were connected to the tower of rectifiers by a short length of 3-inch brass tubing. The condensers employed had each a capacity of 0.001 microfarads with bakelite insulation. Three of these would each stand up to 400 KV., while the fourth was rated at 300 KV. Three of the condensers required insulation from earth and were supported on bakelite cylinders.

Most of the current drawn from the rectifiers was in the form of corona discharge, and at the higher voltages this was slightly over half a milliamperere as measured by a D.C. instrument placed on the earthed side of the transformer

* We are indebted to Messrs. Metropolitan-Vickers Electrical Co., Ltd., for the supply of a quantity of this before it had been placed on the market.

secondary. We should therefore expect a ripple of the order of 1.5 per cent. The wave form has been measured using a cathode ray oscillograph in conjunction with a potential divider and the ripple has been found to be of this order. At the lower voltages the apparatus gave very nearly a fourfold multiplication of the transformer voltage, provided the filaments of the rectifiers were kept sufficiently bright. The emission from the filaments was not sufficiently large to give a fourfold multiplication of voltage at the higher potentials on account of the larger corona losses. The factor varied between three and four and it did not seem worth while dismantling the apparatus to put in filaments which would give the necessary emission. The voltage was measured by sparkover between the 75 cm. diameter aluminium spheres shown in the photograph, Plate 11. The gap was adjusted by raising or lowering the upper sphere.

The Experimental Tube.

The experimental tube consisted of two glass tubes similar to those used in the tower of rectifiers, and is shown in fig. 5. A steel plate, A, was placed between the cylinders, and this formed the support for the electrodes, B. The thin sheets of metal used in the rectifiers would not have been sufficiently rigid to give the accurate alignment of the electrodes which is necessary in this case to direct the beam of ions down the axis of the tube. This metal plate had a 3 feet square piece of sheet metal, C, attached externally which acts as a stress distributor and which is maintained at half the total potential by a connection to the middle point of the tower of rectifiers. Protons were generated in a hydrogen discharge tube, D, placed above the apparatus. The discharge tube was of the Wien type described in the previous paper. The potential applied across the discharge tube was obtained from a 60 KV. transformer, E, fig. 6, the primary of this being supplied with alternating current at low potential. It was found that a much better proton current

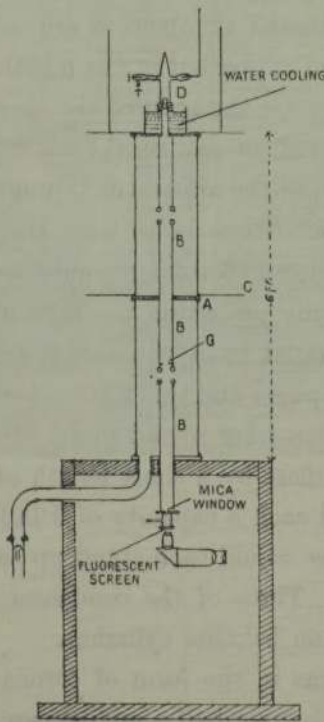

Fig. 5.

could be obtained from the discharge tube when the current sent through it was rectified by placing a small kenetron between it and the transformer.

The usual voltage required on the discharge tube was 40 KV. To supply the exciting current from the mains would have required an insulation transformer to stand 800 KV. between primary and secondary windings, and this would have been bulky and expensive. Its use can, however, be avoided by exciting the transformer from a small alternator which is placed at high potential, the alternator being driven by an insulating belt, F, from a motor at earth potential, as shown in fig. 6. The belt used was a cotton rope, the join being made by splicing. A distance of 8 feet between the motor and the alternator gave ample insulation. The method has been found to be very satisfactory and could be used for still higher voltages.

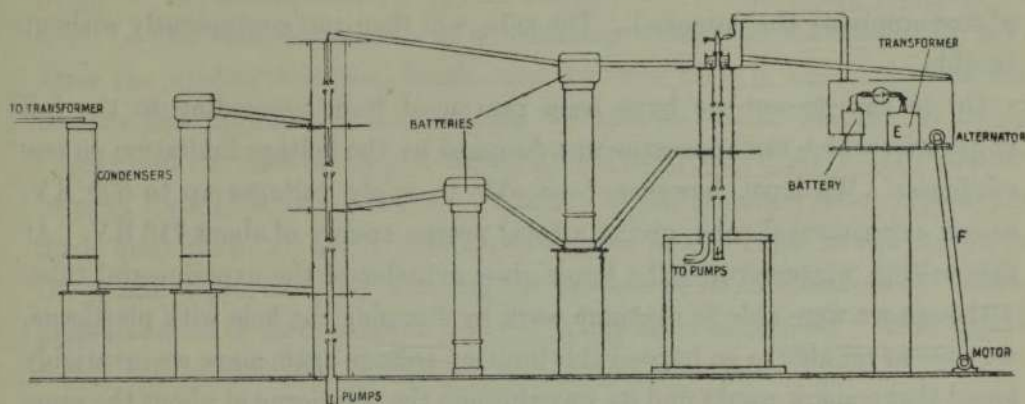

FIG. 6.

The protons passed through a canal in the cathode, passed down the axis of the tube and were accelerated in the space between the electrodes. In the upper cylinder a focussing of the ions was produced in the way described in the previous paper. In the lower cylinder there is less focussing action since the ions are then travelling fast and they are not deviated much by any radial components of the field. This meant that a considerable number of ions struck the ring on the end of the lower electrode and there liberated secondary electrons. Some of these were accelerated towards the upper electrode and there gave rise to X-rays. Some of them struck the wall of the glass tube and the charges built up caused puncture of the glass at comparatively low voltage. Both of these troubles were satisfactorily eliminated by inserting a diaphragm as shown in fig. 5 at G, which prevented the ions from striking the electrodes except at places well inside it, where there was no appreciable field. The tube was evacuated by a fast oil diffusion pump, the connection to the pump being made through 3-inch steam piping. Experiments could be

carried out on the protons by attaching a suitable apparatus at the bottom of the tube.

The Operation of the Apparatus.

When the apparatus is first connected to the transformer it is found that considerable quantities of gas are evolved from the walls. The voltage has to be increased slowly with intervals of a few seconds between the different evolutions of gas to allow the pumps to clear the tubes. Thus it may take a whole day's operation before the full voltage can be applied to the apparatus. After this outgassing process is complete, however, full voltage can usually be obtained within 30 minutes of starting the pumps and within a few minutes of first applying the potential. The tube will then run continuously without trouble.

Up to the present we have been prevented from proceeding to the full voltage for which the apparatus was designed by the voltage limitation on one condenser. We have, however, been able to apply voltages up to 690 KV. to our experimental tube, giving a total proton energy of about 710 KV. At this voltage we punctured the lower glass cylinder of the experimental tube. Although we were able to continue work by stopping the hole with plasticene, we were never able to go beyond this limiting voltage again since we invariably found that a spark would find its way through the plasticene at about the same limiting voltage. We therefore propose to increase the length of our experimental cylinders by 6 inches, and expect that this will enable us to obtain the full 800 KV. It is probable that the puncture of the lower cylinder arose from charging of the walls resulting from secondary electron emission from the electrodes under positive ion bombardment, and that a smaller diaphragm placed in the path of the ions will eliminate the trouble.

Should higher voltages be required in future it would be quite feasible to add another unit to our rectifiers and experimental tube did space allow. It might then be expected that voltages of over a million volts could be used. It would in this case be necessary to take much greater precautions against corona loss than have been necessary in our present apparatus, or to use filaments having much larger emissions.

Experimental Work.

After passing down the axis of the cylindrical electrodes of the tube, the protons emerge through a 3-inch diameter brass tube at the base of the

apparatus, into a chamber well shielded by lead and screened from electrostatic fields. Here any apparatus for experimental work can be attached using a flat joint and a plasticene seal. Proton currents of the order of 10 microamperes can be obtained in this chamber.

When it is desired to carry out experiments at atmospheric pressure the protons can be passed through a thin mica window into the experimental chamber. In the first series of experiments on the range of protons in different gases only a very narrow beam is required. It was therefore a very simple matter to find a piece of mica to act as a window with the necessary small stopping power. A pin hole in a sheet of foil was covered with mica having a weight of 220 micrograms per square centimetre. It was found that protons could be first observed outside at accelerating voltages of the order of 80 KV. After the window had been bombarded for some time it was found that the protons first appeared at accelerating voltages as low as 50 KV. It would appear that the mica is being slowly sputtered away, but it is evidently possible to work for many hours with one window. When the observation chamber is made quite dark it is easily possible to observe luminescence in the gas due to the pencil of protons. By allowing the protons to strike a fluorescent screen, measurements of their range in different gases have been made; these experiments will be described in Part II.

Summary.

In order to obtain high steady potentials for the acceleration of protons, a method has been developed by which the voltage of a transformer can be rectified and multiplied several times by an arrangement of valves and condensers. A rectifier system has been built consisting of four glass cylinders placed end to end, and arranged in the form of a tower 12 feet high, the cylinders containing suitable electrodes and hot filaments and being evacuated continuously. With this apparatus and four condensers, a potential of over 700 KV. has been obtained, which is steady to within a few per cent. The method used is a special case of a more general method of transforming steady potentials from low to high voltages and in the reverse direction.

The voltage of the rectifier is applied to an experimental tube which is built to allow positive ions to be accelerated by the full voltage available. Positive ions of hydrogen are directed down the axis of two glass cylinders and focussed by suitable electrodes, current of the order of 10 microamperes being obtained. Protons having energies up to 710 KV. have been produced and have been

transmitted through a mica window into an experimental chamber at atmospheric pressure where their ranges are measured.

The equipment of the laboratory has been made possible by a special grant from the University.

We wish to express our gratitude to Professor Lord Rutherford for his constant encouragement and support in this work. One of us (E.T.S.W.) is indebted to the Department of Scientific and Industrial Research for a Senior Research award.

*On some Close Collisions of Fast β -Particles with Electrons,
Photographed by the Expansion Method.*

By F. C. CHAMPION, Cavendish Laboratory, Cambridge.

(Communicated by Lord Rutherford, O.M., F.R.S.—Received February 23, 1932.)

[PLATES 12 AND 13.]

1. *Introduction.*

The present paper gives an account of measurements on some close collisions of fast β -particles with electrons, photographed by the Wilson cloud method. These measurements afford a direct test of the applicability of the principles of the conservation of momentum and energy and the principles of relativistic mechanics to individual atomic phenomena.

On the basis of Newtonian mechanics, if one particle collides with another which is initially at rest and the two particles are of equal mass, the angle between the directions of motion of the two particles after collision is equal to 90° for all angles of scattering of the incident particle. On relativistic mechanics, however, this angle becomes a function of the angle of scattering and the velocity of the incident particle, and in particular, it becomes smaller and smaller as this velocity approaches that of light. Qualitative evidence has already been given by Wilson,* Bothe† and others that this angle is less than 90° for the collisions of fast β -particles with electrons, but up to the present no quantitative study has been made of the general relation between

* 'Proc. Roy. Soc.,' A, vol. 104, p. 1 (1923).

† 'Z. Physik,' vol. 12, p. 117 (1922).