

NASA TECHNICAL MEMORANDUM

Revised
NASA TM X-52247

Revised
NASA TM X-52247

FACILITY FORM 602

N67-31966 (ACCESSION NUMBER)	_____	(THRU)
35 (PAGES)	_____	1 (CODE)
TMX-52247 (NASA CR OR TMX OR AD NUMBER)	_____	15 (CATEGORY)

EXPERIMENTS WITH HYDRODYNAMIC JOURNAL
BEARINGS OF VARIOUS MATERIALS AND
DESIGNS IN SODIUM AT TEMPERATURES TO 800°F

by Fredrick T. Schuller, William J. Anderson,
and Zolton Nemeth
Lewis Research Center
Cleveland, Ohio

GPO PRICE \$ _____
CFSTI PRICE(S) \$ _____
Hard copy (HC) 3.00
Microfiche (MF) .65

TECHNICAL PAPER proposed for presentation at Lubrication Conference sponsored by the American Society of Lubrication Engineers and the American Society of Mechanical Engineers Chicago, Illinois, October 17-19, 1967

EXPERIMENTS WITH HYDRODYNAMIC JOURNAL BEARINGS
OF VARIOUS MATERIALS AND DESIGNS IN SODIUM
AT TEMPERATURES TO 800°F

by Fredrick T. Schuller, William J. Anderson, and Zolton Nemeth

Lewis Research Center
Cleveland, Ohio

TECHNICAL PAPER proposed for presentation at
Lubrication Conference
sponsored by the American Society of Lubrication Engineers
and the American Society of Mechanical Engineers
Chicago, Illinois, October 17-19, 1967

NATIONAL AERONAUTICS AND SPACE ADMINISTRATION

**EXPERIMENTS WITH HYDRODYNAMIC JOURNAL BEARINGS
OF VARIOUS MATERIALS AND DESIGNS IN SODIUM
AT TEMPERATURES TO 800° F**

by **Fredrick T. Schuller, William J. Anderson, and Zolton Nemeth**

**Lewis Research Center
National Aeronautics and Space Administration
Cleveland, Ohio**

ABSTRACT

Experiments were conducted with 1.5 inch diameter hydrodynamic journal bearings in liquid sodium at 500 and 800° F, speeds to 12,000 rpm and unit loads to 31 psi. The stability characteristics of five different geometries and the wear and seizure properties of several material combinations were investigated. Tilting pad bearings were most stable. Combinations of a cobalt alloy with nickel alloys or with a titanium carbide cermet showed the best wear and seizure properties.

NOMENCLATURE

C_r = radial bearing clearance, in.

D = bearing diameter, in.

g = acceleration due to gravity, in./sec²

L = bearing length, in.

M = rotor mass per bearing, W_r/g , (lb)(sec²)/in.

N = journal speed, rpm

N' = journal speed, rps

N_T = transitional journal speed from laminar to turbulent regime,

$$\frac{41.1 \nu}{\pi D C_r} \sqrt{\frac{D}{2 C_r}}, \text{ rps}$$

R = bearing radius, in.

Re = Reynolds number, $\pi DN\rho C_r/60\mu$, dimensionless

S = Sommerfeld number, $\frac{\mu N'DL}{W} \left(\frac{R}{C_r}\right)^2$

T_l = Petroff's torque for **laminar** flow, zero load:

$$T_l = \mu \pi^2 D^3 L N / 120 C_r$$

T_t = turbulent torque: $T_t = T_l (0.039 \text{Re}^{0.57})$ (Smith and Fuller, (6))

W = bearing load, lb

W_r = load due to rotor mass, lb ($W_r = Mg$)

$\frac{\sqrt{C_r MW}}{\pi DL \left(\frac{R}{C_r}\right)^2}$ = dimensionless critical rotor mass

μ = absolute lubricant viscosity, lb sec/in.² (reyns)

ν = kinematic viscosity, centistokes (in.²/sec)

ρ = lubricant mass density, lb-sec²/in.⁴

INTRODUCTION

Extended space ~~exploration missions of the future~~ will necessitate ~~long periods of~~ continuous, reliable operation of the power generation system incorporated in the space vehicle. Power levels on the order of 30 000 watts to the million-watt range are anticipated (1). At the present time it appears that a turbogenerator system employing a liquid metal as the working fluid is the most favorable system for the high power levels desired. Requirements for light weight, high reliability, and minimum complexity dictate the use of a hermetically sealed pump with process

fluid lubricated bearings to circulate the fluid through the entire system, including the space radiator.

Fluid film bearings have been selected over rolling element bearings because the former bearing type maintains a full fluid film more easily. This eliminates or minimizes the rubbing contact problem which is usually present in rolling element bearings. Also, the materials problem in fluid film bearings is much simpler because of less stringent hardness requirements

Fluid film bearings do, however, have some disadvantages over rolling contact bearings, namely, increased power losses, greater breakaway torques, and the need for a separate bearing to carry thrust loads. In addition, the disadvantage of principal interest here is the tendency of journal bearings to exhibit instability under light or zero load conditions that will exist in a space vehicle in a zero gravity environment. Instability here refers to half-frequency whirl or the tendency of the journal center to orbit about the bearing center at an angular velocity about half that of the journal around its own center.

Materials chosen as bearing and journal pairs in an alkali metal system must have good resistance to corrosion in the liquid, good wear and seizure resistance, and a low coefficient of friction to insure reasonable breakaway torque. A survey of existing literature on usefulness of materials for bearings in liquid alkali metals (2-4) and the need for using materials of particular expansion coefficients led to the selection of the bearing and journal materials reported herein.

The object of this investigation, the data of which are reported fully in Reference (5), was to determine the stability characteristics of five bearing

configurations and which bearing and journal material combinations had the best compatibility and wear and seizure resistance in liquid sodium at temperatures to 800 F.

The bearings were submerged in the liquid sodium and operated hydrodynamically. Bearings with $1\frac{1}{2}$ -inch bore by $1\frac{1}{2}$ -inch length were tested in liquid sodium at radial loads from 0 to 31.1 pounds per square inch and journal speeds to 12 000 rpm at 500 and 800 F. Bearing friction torque at varying speeds and loads was recorded and compared with theoretical values under both laminar and turbulent flow conditions.

APPARATUS

Bearing Test Rig

A cutaway view of the bearing rig, shown in Fig. 1(a), illustrates the configuration of the rig and its loading mechanism. The test shaft was positioned vertically so that normal gravity forces would not act on the journal. A 15 horsepower dc motor powered the test shaft through a 7.5 to 1 ratio gear box. The sodium test vessel is located immediately below the main support bearing housing and floats between the upper and lower gas bearings as shown schematically in Fig. 1(b). Two semi-circular wheels connected by a cable belt comprise the radial loading system. Radial load was applied by means of an air cylinder between the two semicircular wheels, one of which pivots on a knife edge. Bearing torque is measured by a force transducer. Vertical positioning of the test vessel was achieved by means of a vertically mounted air cylinder located below the vessel.

The test shaft was mounted on two support ball bearings which were preloaded to about 40 pounds by means of a wave spring shown in Fig. 1(a).

This preload was necessary to insure a minimum amount of test shaft run-out. Cooling fins were mounted on the test shaft immediately below the bottom support bearing to dissipate heat and prevent excessive lower support bearing temperatures due to soak back from the high temperature sodium in the test vessel. The test journal was mounted and keyed to the bottom end of the test shaft. The test bearing was mounted in a housing in the test vessel as shown schematically in Fig. 1(b).

Liquid sodium at 400° F was introduced to the test vessel and heated to the desired test temperature by means of an induction heater. The induction heater coil around the test vessel (Fig. 1(b)) does not come into physical contact with the outer surface of the test vessel and therefore does not inhibit its free swinging motion.

A drain was provided at the bottom of the test vessel to facilitate draining of contaminated sodium.

Sodium Supply System

The sodium supply system was a noncirculating, once-through system composed of the following major components: the supply tank, the supply line, the sodium filter, the filter by-pass line, and the control valve.

The supply tank was sized to contain 20 gallons of sodium and was equipped with a fill valve, dual thermowells, diffusional cold trap, pressure transmitter, vapor trap, and a sodium supply line. The liquid metal was supplied to the bearing test rig by means of a differential pressure between the tank and the test rig. A diffusional cold trap was provided to control the sodium oxide content during operation of the sodium system. The cover gas for pressurizing and venting the supply tank was passed

through a wire-mesh demister (vapor trap) which prevented any sodium vapors from getting into the cover gas system.

A micrometallic filter was provided in the supply line to the bearing rig permitting continuous filtering of all supply sodium. The porous micrometallic filter unit was so designed as to permit replacing the filtering element.

Bearings and Journals

Hydrodynamic bearings of five configurations were tested fully immersed in liquid sodium. Bearings with two axial grooves, three axial grooves, a herringbone groove journal with a plain bearing, and tilting pad bearings with three pads were evaluated. One of the three groove bearings was run with an axial flow pump attached to the test shaft, pressure feeding the test bearing through a hole in the test journal.

The bore and length of the bearings in all cases were nominally $1\frac{1}{2}$ inches. The journal outside diameter and bearing inside diameter were machined to a 4 to 8 microinch finish, rms.

A three pad configuration was chosen for the tilting pad bearings because it affords greater load capacity than a configuration of more than three pads. Also, it is much easier to accurately align all pivot points on the common pivot circle center with a three pad configuration than one with more than three pads. The load was applied symmetrically between two support points (pivots).

The bearing and journal materials were: Co-Cr-W, J; Mo-0.5Ti; Ni-Cr-Fe-Mo, X; Ni-Cr; and titanium carbide (K184B). The composition and hardnesses of these materials are given in Table 1.

Instrumentation

Dual Chromel-Alumel thermocouples were attached to the test bearing **back** and into the liquid sodium in the test vessel. The induction heater was controlled by one of the dual thermocouples in the sodium bath.

Two capacitance probes, which measured the movement of the test vessel during a test run, were mounted outside of the test vessel on the vessel cover, 90⁰ from each other. The signal from the probes was fed through displacement meters to an x-y display in an oscilloscope where the actual pattern of motion of the test vessel could be observed. The orbital frequency of the test vessel was measured by means of a frequency counter.

Shorting probes were used in the test vessel to indicate the level of the sodium. These probes would short out when sodium came into contact with them, thereby either lighting a level indicator light or closing the main sodium supply valve automatically.

Test shaft speed was measured with a magnetic pickup head mounted in close proximity to a six-toothed gear on the test shaft. The signal from the pickup was displayed on a four-channel frequency counter.

PROCEDURE

Pretest Preparation for Two and Three Axial Groove Bearings

Prior to each test **run**, the test bearing was assembled into its housing with a slight interference fit. The bearing was then machined in place to a predetermined inside diameter at room temperature that would result in the desired bore size at test temperature. Nine bore gage readings, each accurate to within 0.0001 inch, were averaged and used as a measure of

the bearing bore, The outside diameter **of** the mating journal **was then** ground to a size that would result in the desired clearance **for** the test bearing. To insure a minimum amount of runout, the journal outside diameter was machined to within 0.0002 inch concentricity with its inside diameter.

The test bearing housing was then assembled into the test vessel **which** was carefully raised into position around the test journal on the shaft by means **of** the lower air cylinder.

Pretest Preparation **for** the Tilting Pad Bearings

The radii **of** the three pads **of** a bearing assembly were checked after delivery from the manufacturer to insure an accurate geometry. The **pads** were assembled into an annular housing by means **of** a threaded pivot and nut arrangement. Desired preload was obtained by adjustment **of** the threaded pivots until the bearing surfaces **of** the pads made intimate **con-** tact around a presized set-up plug. The plug was then removed and the tilting pad housing was assembled in a manner like that for the axial groove bearings.

General Pretest Preparation

After the bearing and journal were assembled and the test vessel raised to its run position with the upper and lower **gas** bearings turned on, the test vessel was filled with alcohol and drained as a final cold cleaning procedure. The test vessel was then purged with argon and a cover gas **of** argon was supplied to the test vessel throughout the test. The test vessel was preheated to 500 F and liquid sodium at about 400 F was introduced into the test vessel through the inlet port under about 5 pounds per

square inch pressure from the 20-gallon supply system. Sodium flowed into the test vessel until it made contact with the liquid level probe which automatically closed the main sodium supply valve preventing overfilling.

With the bearing and journal completely submerged in sodium, the test vessel was heated to 500 F and allowed to soak for approximately 4 hours to remove remaining contaminants. The vessel was then drained and refilled with clean sodium and the bearing test was started after equilibrium conditions had been attained.

Test Procedure

Two types of tests were conducted, one with load and the other at zero load conditions. Under **zero** load conditions the semicircular wheel that pivots on a knife edge was removed along with its loading cable. The force transducer for torque measurement was attached directly to the semicircular wheel on the test vessel.

Shaft speed was increased in 1000 rpm increments from 3000 rpm to a maximum of 12 000 rpm. In the loaded bearing tests, the loads were changed as required to fulfill the purpose of the particular test run. In some tests the load had to be changed to maintain bearing stability and in others the load was left unchanged to observe the effect of prolonged instability in a bearing. The time interval between speed and load changes varied, but was of sufficient duration so as to allow the friction torque to stabilize. Speed, load, bearing temperature, and bearing friction torque were recorded at each speed and load condition.

Test vessel movement was noted by observation of the oscilloscope screen in an attempt to identify bearing instability at each test interval.

A test was terminated for the following reasons: (a) if the bearing seized, (b) if the bearing showed indications of imminent failure by erratic or excessively high torque, (c) if the test vessel no longer floated freely on its gas bearings, or (d) if the desired objective of the test had been attained.

RESULTS AND DISCUSSION

Two and Three Axial Groove Cylindrical Bearings

The results of tests on **14** two and three axial groove bearings are summarized in Table **2**. The results of these tests, which were conducted over a speed range to 11 000 rpm at unit loads to **26.7** pounds per square inch, were generally poor. Some rig problems were encountered in the early phase of the test program. These problems included test vessel cocking, which caused excessive wear at the ends of one bearing and one seizure, and contamination of the sodium which may have caused four failures due to particle ingestion into the test bearing clearance area. In three instances, sodium migrated into the upper gas bearing causing the test vessel to cock, producing erratic torque readings.

A typical failure caused by contaminant particle ingestion is shown in Fig. **2**. This type of failure resulted in a rather pronounced gouge in the bearing and journal. It was after this type of failure that a cleaning procedure was adopted in which the test bearing and journal were soaked for **4** hours in the sodium bath at 500 F in the test vessel. The contaminated sodium was then drained and a clean supply of filtered sodium was introduced into the test vessel before a test was begun.

In some instances, at the higher speeds, excessive sloshing of sodium in the test vessel caused some sodium to migrate up into the top gas bearing of the test vessel. These sodium droplets would solidify and test

vessel cocking would result causing bearing failure.

The generally poor results obtained with the two and three axial groove bearings was principally due to their inherent instability which will be discussed in the section,, Bearing Instability.

Herringbone Journal Bearing

Table 3 summarizes the results of experiments with two herringbone groove journals running in plain cylindrical bearings. These bearings, one of which is illustrated in Fig. 3, were tested in an effort to determine their stability characteristics.

The two herringbone journal bearings were run over a speed range of 4000 to 12 000 rpm at loads of 4 to 20 psi at sodium temperatures of 500 and 800 F. Higher bearing torques were observed than for the two and three axial groove bearings due to the pumping action of the herringbone grooves.

Bearing MP-3 (Table 3) ran for 490 minutes and showed very little wear (Fig. 3). The slight scoring of the journal was probably due to a small contaminant particle. Bearing MP-4 seized after 90 minutes due to a line heater expansion pushing the test vessel and overloading or cocking the bearing.

Tilting Pad Bearings

Five tilting pad bearings having a three-pad configuration were tested in sodium at 500 and 800 F at speeds to 12 000 rpm and loads to 70 pounds (31.1 psi). These results are summarized in Table 4. Of the five bearings tested, one seized due to overloading (bearing number T-2, Table 4), and one seized due to a combination of insufficient clearance and incom-

patible bearing and journal material (bearing number T-1A, Table 4). The wear on the unloaded pad of bearings T-1 and T-2A1, recorded in Table 4, was probably due to insufficient preload which resulted in pad flutter.

Table 4 lists the various preload coefficients that were investigated. Although inconclusive, because of the limited number of tests, it appeared that tilting pad bearings with large machined in radial clearances (0.0028 to 0.0036 in.) and high preload coefficients (0.50 to 0.72) yielded the best test results, as far as wear to pads is concerned.

Figure 4 shows a tilting pad bearing that failed due to overloading. Pads B and C were the loaded pads, with most of the wear shown on the leading edge of pad C. Analysis of the wear pattern on the outer edges of all three pads would indicate that the pads had rolled. The surface damage to the unloaded pad A was attributed to the failure of this bearing when wear debris was transferred completely around the bearing just prior to seizure.

Bearing torque data obtained from tilting pad bearings at zero load and at 10-pound radial load are shown in Figs. 5(a) and (b). These data are shown compared to the theoretical laminar torque calculated from the Petroff equation,

$$T_l = \frac{\mu \pi^2 D^3 L N}{120 C_r}$$

and the theoretical turbulent torque calculated from the equation given by Smith and Fuller (6) where

$$T_t = T_l(0.039 \text{ Re}^{0.57})$$

The theoretical torques are for a full circular bearing with zero eccentricity, so they are only rough approximations for a tilting pad bearing,

and only for zero preload. Bearing torque values indicated that turbulent flow conditions prevailed over the greater part of the speed range, due primarily to the low sodium viscosity. The experimental transitional speed, where the bearing passes from the laminar to the turbulent regime, occurred at a higher speed than that predicted by theory (critical transitional speed, N_T). This may be due to the fact that this transition occurs over a range of speeds rather than at one definite speed. Similar results with the transition speed were reported in Reference (7).

No abrupt increase in torque readings was noticed when turbulent flow conditions were approached. The rather gradual increase in torque with speed made it difficult to specify exactly the speed at which full turbulence was attained.

Bearing Instability

The bearing instability of principal concern here is half-frequency whirl. Figure 6 shows oscilloscope traces of bearing motion obtained with a two axial groove bearing in sodium at 500 F with a 10-pound radial load. At 4100 rpm the trace indicated stable bearing operation (Fig. 6(a)). When the speed was increased to 5000 rpm, however, the increase in attitude angle was sufficient to sustain half-frequency whirl. The whirl pattern observed on the oscilloscope screen is shown in Fig. 6(b). If the bearing is allowed to operate unstably, the supporting film between the bearing and journal soon breaks down, and the bearing eventually fails.

One of the most undesirable characteristics of the two and three groove bearings was their instability. The result of such instability is clearly shown in Fig. 7. Test bearing J-2 is shown in this figure after

257 minutes of operation at 11 psi unit bearing load in 500 F sodium under half-frequency whirl conditions. The excessive wear shown is the result of unstable bearing operation.

Of the 14 two and three groove cylindrical bearings tested, five showed excessive wear due to half-frequency whirl and one seized because of this instability.

One of the three groove bearings (bearing number **M-9**, Table 2) was loaded sufficiently at each speed throughout its evaluation to keep it running stably. After 290 minutes of running time in 500 F sodium, the bearing was removed and no measurable wear was present on either the journal or the bearing. The maximum load on this bearing was 26.7 psi at a maximum speed of 10 000 rpm indicating that a three groove cylindrical bearing will run successfully in sodium if properly loaded to suppress half-frequency whirl.

Theory indicates that herringbone groove bearings operate at considerably lower attitude angles than do smooth bearings resulting in more favorable stability characteristics. This type of bearing assembly was indeed more stable than the two and three groove bearings and plain journal assemblies. However, the herringbone groove bearing assembly did show evidence of half-frequency whirl at low load conditions. A more judicious design of the herringbone groove journal might lead to a bearing that would be stable even at zero load conditions. Such a bearing has been run at zero load in air up to 60 000 rpm without any evidence of half-frequency whirl (8).

Figure 8 shows the relative stability of the four different cylindrical bearing configurations tested. The two and three axial groove bearing

configurations were the least stable of the four since they required the highest load at any specific speed to maintain stable operation. The plain bearing with a herringbone groove journal was the most stable of the four since it required the lowest load at a given speed to keep it running stably. Axial grooved bearings appeared to require a linear increase in load with speed to maintain stable operation whereas the herringbone groove bearing was stable at 11.1 pounds per square inch unit load at speeds of 7000 to 10 000 rpm.

Experimental data on the threshold of instability of two and three axial groove bearings correlated well with the theoretical curves plotted with the aid of theoretical data reported in Reference (9). Figure 9 shows theoretical curves of Sommerfeld number plotted against the dimensionless critical rotor mass for a 100° partial bearing and full circular journal bearing. The data points for the two axial groove and three axial groove bearings generally fall between the curves indicating good correlation.

The procedure for determining the threshold speed is to calculate the dimensionless rotor mass

$$\frac{\sqrt{C_r MW}}{\mu DL \left(\frac{R}{C_r}\right)^2}$$

Enter Fig. 9 with this value and determine the corresponding Sommerfeld number using the appropriate bearing curve. The speed corresponding to this Sommerfeld number is the threshold speed, that is, the rotor speed at onset of instability.

The tilting pad bearings were the most stable of the five configurations tested. Tilting pad bearings T-3 and T-2A1 were run up to 11 000 rpm at zero load without exhibiting any half-frequency whirl instability.

Although not tested at zero load, the remaining three bearings of the tilting pad group showed good stability at light loads of 4.5 psi to speeds of 11 000 rpm.

Material Compatibility

Table 5 lists the bearing and journal material combinations that had good wear and seizure properties in sodium to 800 F.

Co-Cr-W, J material mated with Ni-Cr-Fe-Mo, X, titanium carbide (K184B), or Ni-Cr showed the best wear and seizure properties. Also titanium carbide (K184B) mated with Mo-0.5Ti, showed excellent promise. Materials such as Ni-Cr-Fe-Mo, X and Ni-Cr, having high nickel content, were prone to catastrophic seizure when paired in a bearing and journal combination.

Figure 10 shows the results of a seizure of a three axial groove bearing due to an incompatible bearing and journal material combination. The bearing material was Mo-0.5Ti and the journal, Ni-Cr-Fe-Mo, X. The surface of the journal shows a galling typical of this type of failure,

Another example of the results of pairing incompatible materials is shown in Fig. 11. The bearing material was Ni-Cr and the journal material was Ni-Cr-Fe-Mo, X, both high in nickel content. Seizure resulted in galling of the pads and journal. The bearing radial clearance at the pivots of 0.0003 inch would not allow many particles to pass through the bearing without initiating surface damage. With a poor combination of materials,

galling, severe surface damage, and possible seizure quickly follow the initial surface damage.

Figure 7 shows an example of mating materials with good compatibility. The combination of Co-Cr-W, J and Ni-Cr-Fe-Mo, X material showed excellent seizure resistance since this bearing and journal combination did not seize even after prolonged operation with whirl present which produced the excessive wear shown in the figure. Figure 12 shows a photograph of the pivot arrangement used on the tilting pad bearings: a sphere against a flat. Figure 13 shows a typical example of surface damage to the pivot that was observed in some tests, even after very short runs at light load. This damage occurred with both the titanium carbide (K162B) and the Co-Cr-W, J pivot materials which were always mated against themselves. As shown in Table 4, bearing number T-1 ran for 175 minutes with a maximum load of 15 pounds on the pivot producing a Hertz stress of only 52 600 psi which was sufficient, however, to cause slight pivot surface damage.

SUMMARY OF RESULTS

A series of hydrodynamic journal bearing experiments was run in sodium at 500 and 800 F at speeds to 12 000 rpm and unit loads to 31.1 pounds per square inch. Five different configurations were tested; cylindrical bearings with two and three axial grooves, plain cylindrical bearings with herringbone groove journals, and tilting pad bearings with three pads. The bearing bore in all cases was 1.5 inches and all bearings had a length to diameter ratio of 1. The following results were obtained:

1. The tilting pad bearings were the most stable. Following in order were: (a) plain cylindrical bearing with a herringbone groove journal, (b) three axial groove bearing, pressure fed from an axial shaft pump through a hole in the journal, and (c) three and two axial groove bearings.

2. Co-Cr-W, J material mated with Ni-Cr-Fe-Mo, X, titanium carbide (K184B), or Ni-Cr showed the best wear and seizure properties. Also titanium carbide (K184B) mated with Mo-0.5Ti showed excellent promise. Materials having high nickel content, such as Ni-Cr-Fe-Mo, X and Ni-Cr, were prone to catastrophic seizure when paired in a bearing and journal combination.

3. Data on the threshold of instability of circular, grooved bearings obtained from this investigation compared favorably with predicted theoretical values.

4. Actual bearing torque values (for the tilting pad bearings) agreed favorably with turbulent flow theory, indicating that turbulent flow conditions prevailed over the greater portion of the tested speed range, due primarily to the low sodium viscosity. Critical transitional speed from laminar to turbulent flow occurred at a higher speed than the theoretical Taylor criterion predicts. Similar results were reported in Reference (7).

5. No abrupt increase in torque readings was noticed when turbulent flow conditions were approached, indicating that the transition from laminar to turbulent flow occurs gradually over a range of Reynolds numbers rather than suddenly. The rather gradual buildup of torque made it difficult to specify exactly at what speed turbulence was initiated.

6 Surface damage of the tilting pad bearing pivots was observed in some tests even after very short runs at light pivot loads. The pivot configuration used in this investigation was a spherical surface against a flat and the materials were titanium carbide (K162B) against itself and Co-Cr-W, J against itself.

7. Although inconclusive, because of the limited number of tests, it appeared as though the tilting pad bearings with large machined-in clearances (0.0028 to 0.0036 in. radial) and high preload coefficients (0.50 to 0.72) yielded the most favorable test results. (These bearings had radial clearances at the pivots of 0.003 to 0.0017 in.) The tilting pad bearings were the most stable of the five configurations tested.

REFERENCES

1. Slone, H. O.; and Lieblein, S.: "Electric Power Generation Systems for Use in Space." Paper presented at Second Int. Cong., Int. Council of Aero Sci., Zurich, Switzerland, Sept. 12-16, 1960.
2. Basham, S. J.; Stang, J. H.; and Simons, E. M.: "Corrosion Screening of Component Materials for NaK Heat Exchange Systems." Battelle Memorial Inst., Columbus, Ohio. Preprint 24 Session XXII. Contributed by American Institute of Chemical Engineers, 1958.
3. Apkarian, H.: "Investigation of Liquid Metal Lubricated Bearings." Rep. 50GL231, General Electric Co., Nov. 27, 1950.
4. Cook, W. H.: "Corrosion Resistance of Various Ceramics and Cermets to Liquid Metals." Rep ORNL - 2391, Oak Ridge Nat. Lab., June 15, 1960.

5. Schuller, F. T.; Anderson, W. J.; and Nemeth, Z. N.: "Operation of Hydrodynamic Journal Bearings in Sodium at Temperatures to 800^o F and Speeds to 12,000 rpm." NASA TN D-3928, April 1967.
6. Smith, M. I.; and Fuller, D. D.: "Journal Bearing Operation at Super-Laminar Speeds," Trans. ASME, vol. 78, 1956.
7. Stahlhuth, P. H.; and Trippett, R. J.: "Liquid Metal Bearing Performance in Laminar and Turbulent Regimes." Trans. ASLE, vol. 5, no. 2, Nov. 1962, pp. 427-436.
8. Malanoski, S. B.: "Experiments on an Ultra-Stable Gas Journal Bearing." MTI-65TR37. Mechanical Technology, Inc., Nov. 1965.
9. Churchill, A. V.: "Rotor Bearings Dynamics Design Technology Part III - Design Handbook for Fluid Film Type Bearings." Tech Rept. AFAPL TR-65-45, Part III, May 1965, Wright-Patterson Air Force Base, Ohio.

TABLE 1. - NOMINAL COMPOSITION AND HARDNESS OF BEARING AND JOURNAL MATERIALS

Material	Rockwell hardness, room temp.	Composition												
		Al	C	Cr	Co	Fe	Mn	Ni	Si	W	Ti	TiC	Mo	Others
Co-Cr-W, J	C-62	--	2.5	32	40.5	3	----	2.5	----	17	---	--	----	2.5
Ni-Cr-Fe-Mo, X	B-87	--	0.2	22	1.5	18	----	47.2	----	0.6	---	--	9	1.5
Mo-0.5Ti	B-87	--	----	--	----	--	----	----	----	----	0.5	--	99.5	----
Titanium carbide (K-184B) (nickel bonded)	B-75 to B-95	--	0.04	15	----	5	0.35	48	0.20	----	----	--	----	----
	C-67	3	----	3	----	--	----	40	----	----	----	50	4	----

TABLE 2. - RESULTS OF 2 AND 3 GROOVE BEARING TESTS IN SODIUM

Bearing number	Bearing material	Bearing type	Test temperature °F	Measured radial clearance at test temperature, in.	Journal speed range tested rpm	Unit load range tested psi	Total test time, min	Observed instability	Remarks
Journal number	Journal material								
M-1	Mo-0.5Ti	2 Groove	500	0.0010	3000 to 8000	4.5 to 20.0	470	4t various speed and load condition	Bearing and journal showed moderate wear due to half-frequency whirl. Increasing load stabilized bearing. Bearing did not seize. Ran deliberate half-frequency-whirl operation at momentary intervals
K-6	TiC								
M-7	Mo-0.5Ti	2 Groove	800	0.0010	4000 to 11 000	4.5 to 20.0	703	Tone present	Bearing showed moderate wear at both ends indicating the test vessel had cocked. Bearing did not seize. Sodium had migrated to top gas bearing of test vessel.
K-B	TiC								
J-1	Co-Cr-W, J	3 Groove	500	0.0013	5000	22.0	5	Not set up to observe	Contaminant particle score bearing and caused seizure almost immediately after start of test.
HX-B	Ni-Cr-Fe-Mo, X								
J-2	Co-Cr-W, J	3 Groove	500	0.0012	5000 to 7000	11.0	257	4t 7000 rpm and 11.0 psi load	Bearing and journal showed severe wear but no seizure resulted. Held bearing at 7000 rpm and 11.0 psi deliberately for 90 minutes to observe results of half-frequency-whirl operation
HX-C	Ni-Cr-Fe-Mo, X								
J-3	Co-Cr-W, J	3 Groove	500	0.0011	5000 to 7000	9.0	260	Yet set up to observe	Bearing and journal showed heavy wear probably due to unstable operation at light load. Bearing did not seize.
HX-D	Ni-Cr-Fe-Mo, X								
HX-B	Ni-Cr-Fe-Mo, X	3 Groove	500	0.0011	5000	11.0	30	Tot set up to observe	Bearing seized after 30 minutes apparently due to contaminant particle
J-5	Co-Cr-W, J								
HX-D	Ni-Cr-Fe-Mo, X	3 Groove	500	0.0015	3000 to 7000	4.5 to 8.9	460	Not set up to observe	Bearing and journal showed heavy wear but did not seize. Light loads probably caused the bearing to run unstably.
J-6	Co-Cr-W, J								
HX-5	Ni-Cr-Fe-Mo, X	3 Groove	800	0.0008	5000	Not recorded	Not recorded	Too short a run to observe	Bearing seized immediately, probably due to contaminant particle. Bearing showed a score mark completely around on one end.
J-3	Co-Cr-W, J								

TABLE 2. - Concluded. RESULTS OF 2 and 3 GROOVE BEARING TESTS IN SODIUM

Bearing number	Bearing material	Bearing type	test temperature °F	Measured radial clearance at test temperature, in.	Journal speed range tested, rpm	Unit load range tested psi	Total test time, min	Observed instability	Remarks
Journal number	Journal material								
K-3	TiC	3 Groove	500	0.0017	5000	4.5	315	Not set up to observe	Bearing and journal showed heavy wear but did not seize. Bearing apparently was operating unstably because of light load.
J-7	Co-Cr-W, J								
M-9	Mo-0.5Ti	3 Groove	500	0.0010	5000 to 10 000	11.0 to 26.7	290	At various speeds and load conditions	Bearing and journal showed discoloration but no measurable wear. Bearing was purposely loaded sufficient to keep it running stably. Also ran deliberate half-frequency-whirl operation at momentary intervals.
J-11	Co-Cr-W, J								
M-12	Mo-0.5Ti	3 Groove	800	0.0011	5000 to 10 000	13.3 to 22.2	355	None present	Bearing was loaded sufficient to keep it running stably; however, bearing seized at 8000 rpm during shutdown. 1/8 inch gall mark around bearing possibly caused by contaminant particle, otherwise light wear.
J-1	Co-Cr-W, J								
M-10	Mo-0.5Ti	3 Groove	800	0.0010	4000 to 7000	15.5 to 17.8	242	None present	Bearing seized at 7000 rpm and 17.8 psi load. Two small wear areas on each end of bearing indicating the test vessel had cocked.
J-2	Co-Cr-W, J								
M-11	Mo-0.5Ti	3 Groove	800	0.0013	Not recorded	0	Not recorded	Present immediately	Bearing seized immediately at 0 load with definite indication of half-frequency whirl. Wear on both ends of bearing was observed.
Hx-7	Ni-Cr-Fe-Mo, J								
Hx-7	Ni-Cr-Fe-Mo, J	3 Groove	500	0.0012	4000 to 9000	13.3 to 22.2	647	At various speed and load condition,	A shaft screw pump forced sodium into the bearing through a hole in the journal. Bearing showed small wear area in loaded zone probably due to deliberate half-frequency-whirl operation at momentary intervals.
J-8	Co-Cr-W, J								

^aBy observation of oscilloscope pattern as the test vessel **was** moved by hand, to the limits of its outward motion, in a circular orbit about the stationary journal.

E-3570

TABLE 3. - RESULTS OF PLAIN CYLINDRICAL BEARING AND HERRINGBONE GROOVE JOURNAL TESTS IN SODIUM

Bearing number	Bearing material		Bearing type	Test temperature, °F	Measured ^a radial clearance at test temperature, °F (on lands)	Journal speed range tested, rpm	Unit load range tested, psi	Total test time, min	Groove angle (measured from a perpendicular to the journal axis) (β)	Number of grooves and lands	Width of grooves and lands, in.	Depth of grooves, in.	Observed instability	Remarks
	Journal number	Journal material												
MP-3	Mo-0.5Ti		Plain bearing. Herringbone groove journal	500	0.0013 (on lands)	40 to 200	10 to 17.8	490	33°	20	0.04	0.0014	At various speed and load conditions	Light wear on bearing and journal, due to deliberate half-frequency-whirl operation at momentary intervals.
K-14	TiC													
MP-4	Mo-0.5Ti		Plain bearing. Herringbone groove journal	800	0.0008 (on lands)	500 to 800	10 to 20.0	90	3°	0	0.04	0.0014	At 500 rpm and 0 load	Bearing seized due to overload caused by heater expansion pushing test vessel increasing radial
K-A	TiC													

^a by observation of oscilloscope pattern as the test vessel was moved by hand, to the limits of its outward motion, in a circular orbit about the stationary journal.

^b Zero load only momentary since half-frequency-whirl occurred.

TABLE 4. - RESULTS OF TILTING PAD BEARING TESTS IN SODIUM

Bearing number	Bearing material	Bearing type	Test temperature, °F	Measured ^a radial clearance at test temperature, °F	Preload coefficient	Journal speed range tested, rpm	Unit load range tested, psi	Total test time, min	Observed instability	Remarks
T-1	Ni-Cr	3 Tilting pad	500	$C_p = 0.0021$	0.19	500 to 1000	4.5 to 6.7	175	None present	Very little wear observed with most wear on unloaded pad. Pivot surfaces showed slight surface damage.
J-10	Co-Cr-W, J			$C_p = 0.0017$						
T-2	Ni-Cr	3 Tilting pad	60	$C_p = 0.0011$	0.3	500 to 900	4.5 to 31	31	None present	Bearing seized at 9000 rpm at 31 psi because of overloading. Loaded pad showed most wear.
J-12	Co-Cr-W, J			$C_p = 0.0007$						
T-2A1	Ni-Cr	3 Tilting pad	60	$C_p = 0.0028$	0.9	500 to 1000	0 to 8.9	60	None present	Unloaded pad showed most wear indicating possibly insufficient preload. Journal showed light wear. Pivots showed mating surface damage.
J-13	Co-Cr-W, J			$C_p = 0.0014$						
T-3	Ni-Cr-Fe-Mo, X	3 Tilting pad	500 and 800	$C_p = 0.0036$	0.7	500 to 1000	0 to 17.8	1013	At 1200 rpm and 0 pad	Very little wear on all shoes. Pivots showed mating surface damage. Clearance at 800 F was not appreciably different from 500 F.
J-14	Co-Cr-W, J			$C_p = 0.0010$						
T-1A	Ni-Cr	3 Tilting pad	60	$C_p = 0.0010$	0.5	500 to 800	4.5	15	None present	Bearing seized when higher load than 4.5 psi was attempted, probably due to tight clearance and incompatible materials. Wear evenly distributed.
HX-8	Ni-Cr-Fe-Mix			$C_p = 0.0003$						

^a Observation of oscilloscope pattern as the test vessel was moved by hand, to the limits of its outward motion, in a circular orbit about the stationary journal.

^b C_p = bearing radial clearance before preload.

^c C_p = bearing radial clearance at pivot location after preload.

**TABLE 5. - BEARING AND JOURNAL MATERIAL
COMBINATIONS THAT HAVE GOOD RESISTANCE
WEAR AND SEIZURE IN SODIUM TO 800 F**

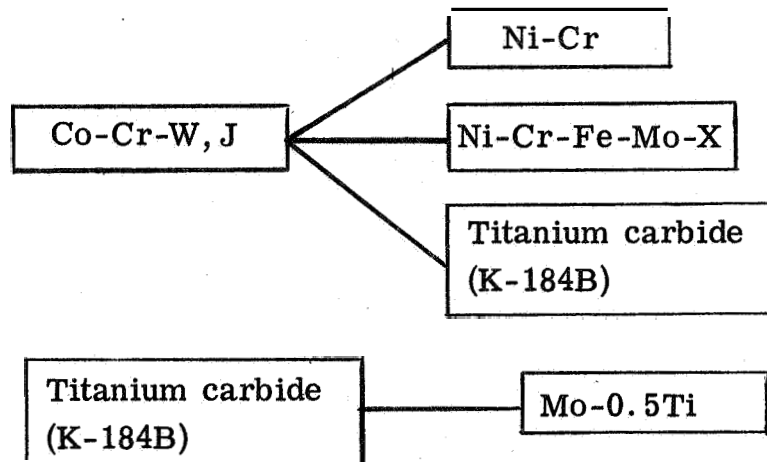

E-3570

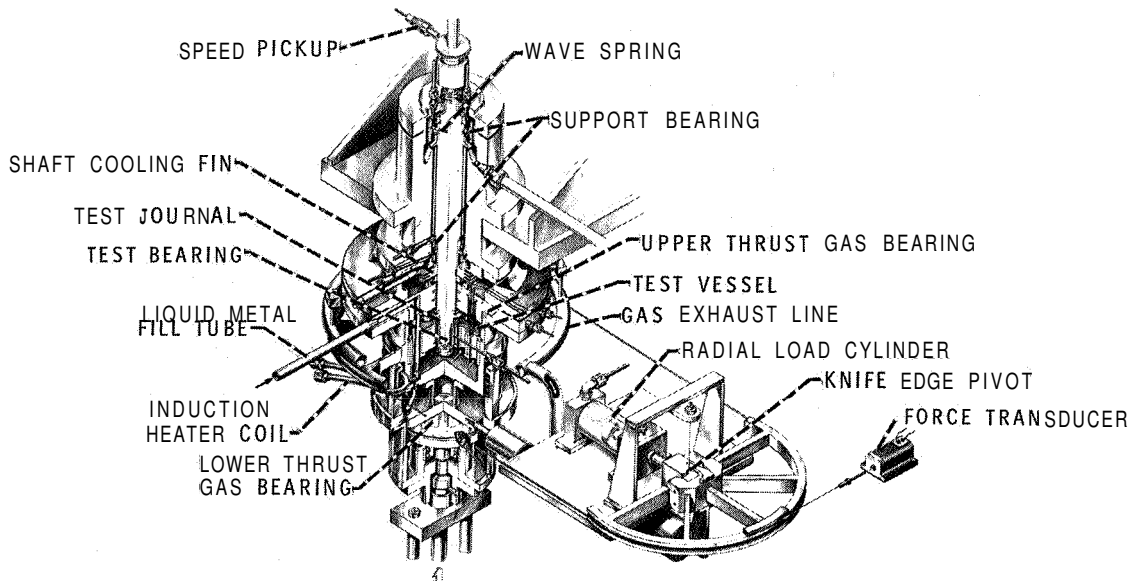

(a) Cutaway view.

Figure 1. - Liquid metal bearing rig.

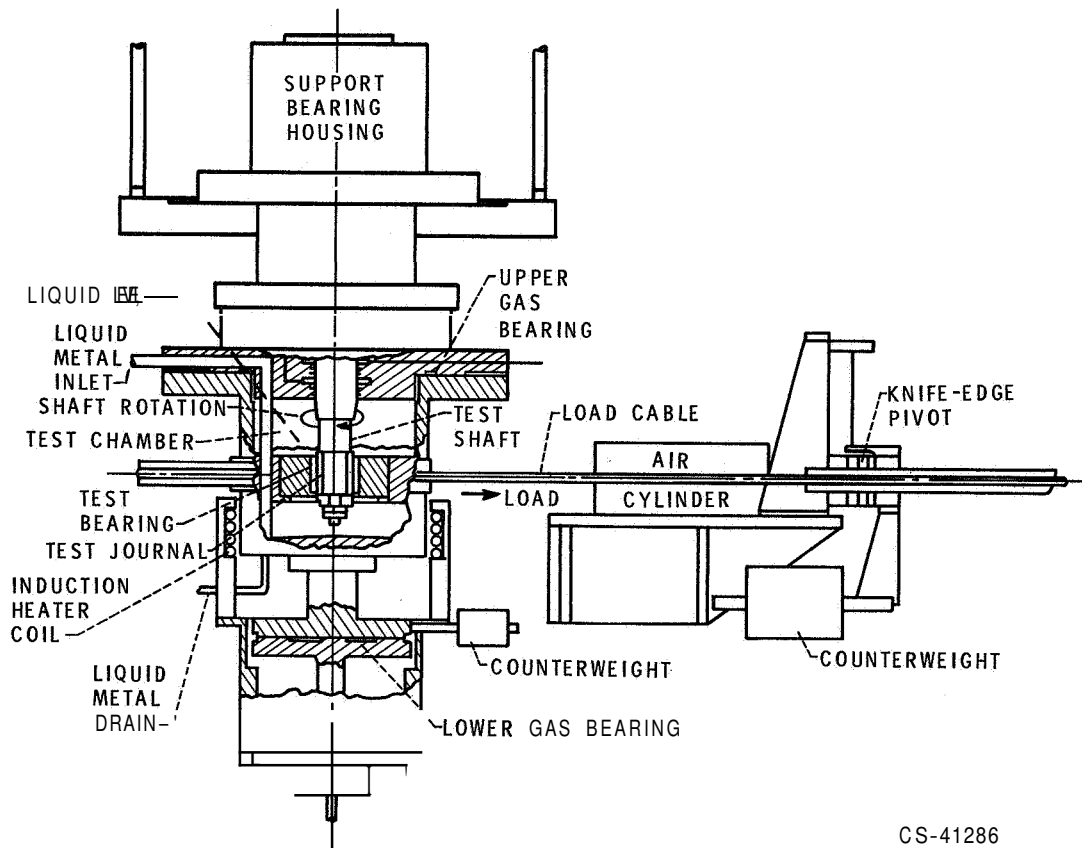

CS-41286

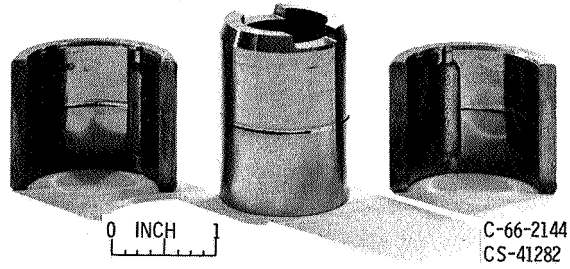

Figure 2. - Seizure caused by contaminant particle. Bearing (J-1) versus journal (HX-B).

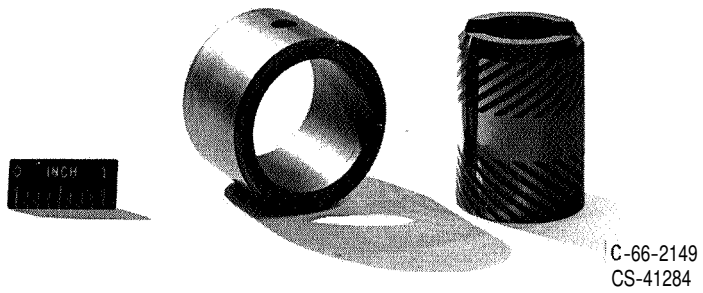

Figure 3. - Plain bearing (MP-3) versus Herringbone groove journal (K-14) after test.

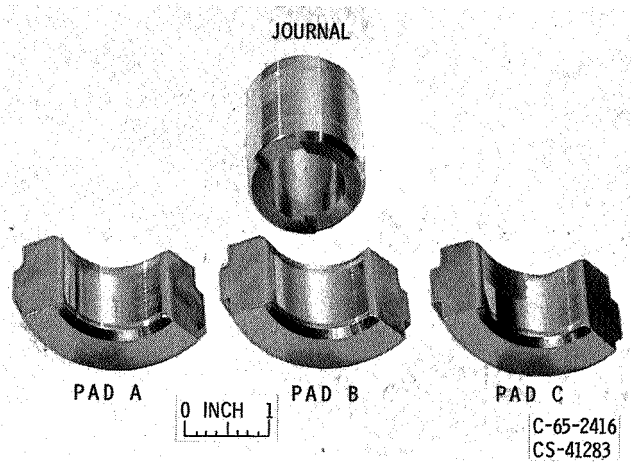
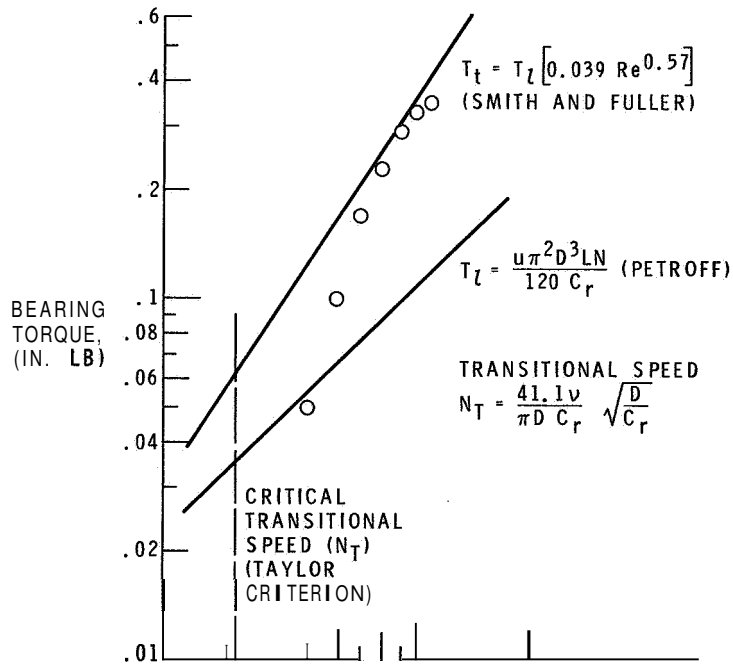
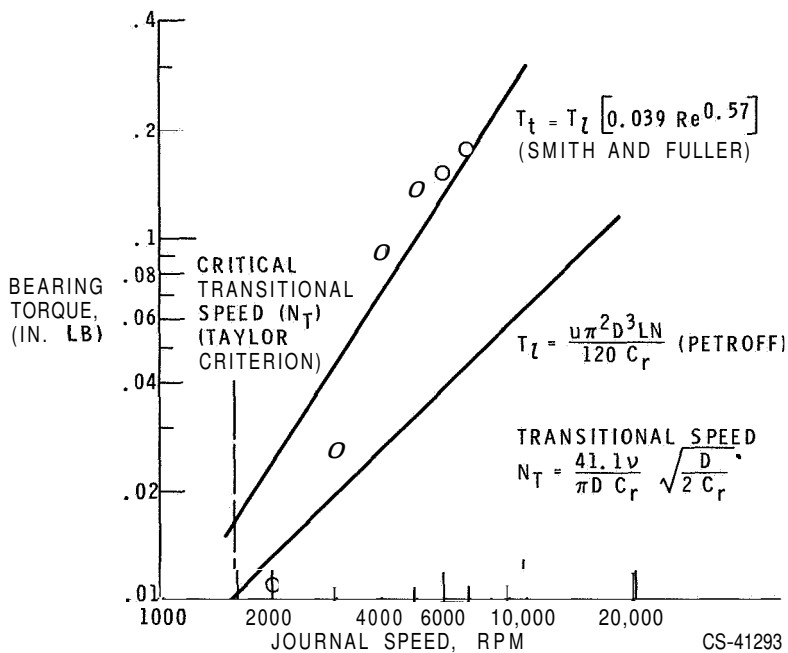

Figure 4 - Failure due to overloading. Tilting pad bearing (T-2) versus journal (J-12).



(a) Bearing material, Ni-Cr; radial clearance, 0.0021 inch; load, 10 pounds.

Figure 5 - Comparison of experimental and theoretical friction torques for three-pad tilting-pad bearing. Lubricant 500° F sodium; journal material, Co-Cr-W, J; nominal diameter, 1.5 inches; nominal length, 1.5 inches.



(b) Bearing material, Ni-Cr-Fe-Mo, X; radial clearance, 0.0036 inch; zero load.

Figure 5. - Concluded.

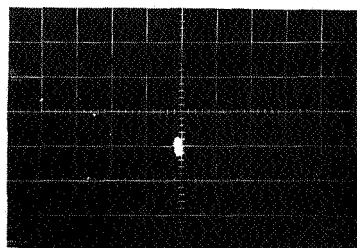

1 CM = 0.5 MILS
(A) STABLE OPERATION
 AT 4100 RPM; 10-LB
 RADIAL LOAD.

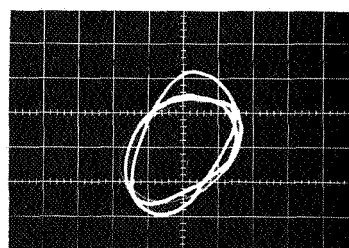

1 CM = 0.5 MILS
(B) UNSTABLE OPERATION
 (HALF FREQUENCY
 WHIRL) AT 5000 RPM;
 10-LB RADIAL LOAD.

CS-41290

Figure 6. - Oscilloscopetraces of bearing motion obtained with a two-axial groove bearing in sodium at 500° F. Diametral clearance, 0.0020 inches. Bearing (M-1) against journal (K-6).

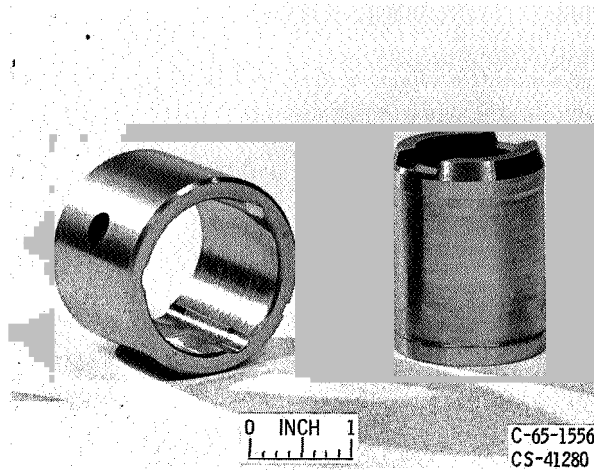

Figure 7. - Wear due to unstable bearing operation (one-half frequency whirl). Co-Cr-W, J bearing (J-2) versus Ni-Cr-Fe-Mo, X journal (HX-C).

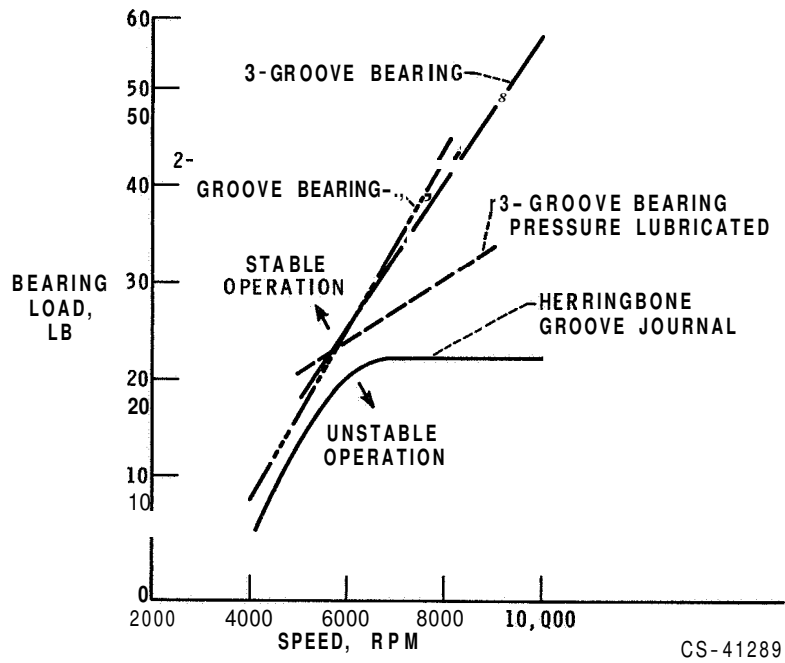

Figure 8 - Speed versus load at which bearing half frequency whirl is initiated. Comparison of 4 different bearing and journal configurations.

CS-41289

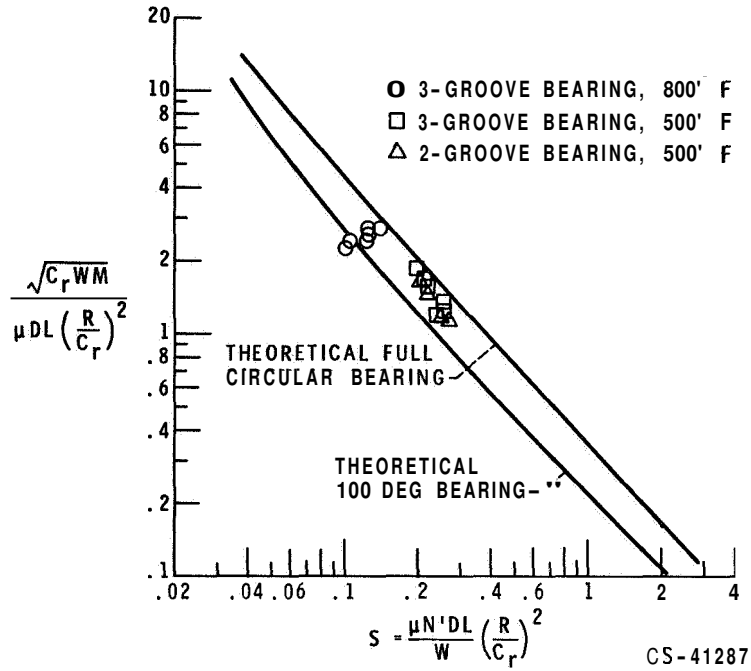
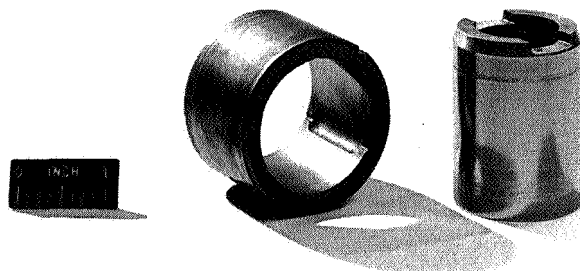

Figure 9. - Dimensionless critical rotor mass as a function of Sommerfeld number at the onset of half-frequency whirl for the plain cylindrical and the 100° partial arc bearings operating with a turbulent film.



C-66-2148
CS-41281

Figure 10. - Seizure due to incompatible material combination. Mo-0.5Ti bearing. (M-11) versus Ni-Cr-Fe-Mo, X journal (HX-7).

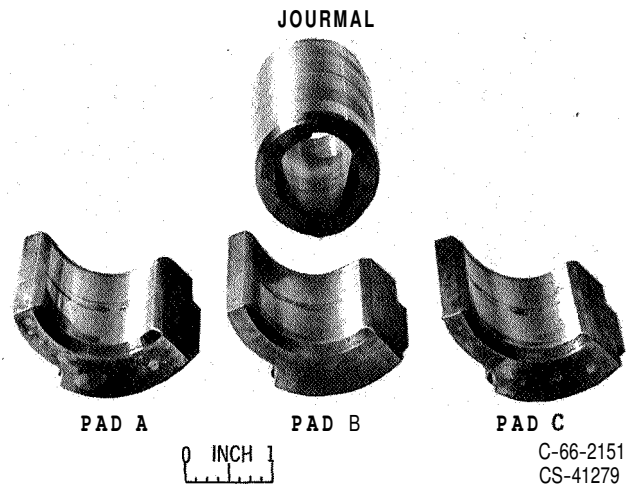

Figure 11. - Tilting pad bearing seizure due to incompatible material combination. Ni-Cr bearing (T-1A) versus Ni-Cr-Fe-Mo, X journal (HX-8).

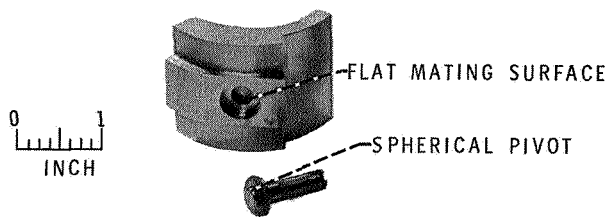

Figure 12. - Spherical pivot and flat mating surface in pad. (Titanium carbide (K162B) versus (Titanium carbide (K162B)).

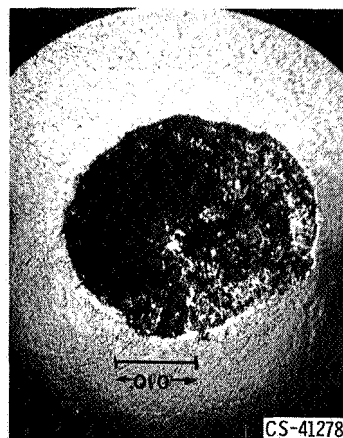

Figure 13. - Surface damage to spherical pivot (titanium carbide - K 162B) for tilting pad bearing after operation in sodium.