Electronic Theses and Dissertations, 2004-2019

2011

Expression Of Trichoderma Reesei Beta]-mannanase In Tobacco Chloroplasts And Its Utilization In Lignocellulosic Woody Biomass Hydrolysis

Pankaj M. Agrawal
University of Central Florida



Part of the [Biotechnology Commons](#), and the [Molecular Biology Commons](#)

Find similar works at: <https://stars.library.ucf.edu/etd>

University of Central Florida Libraries <http://library.ucf.edu>

This Masters Thesis (Open Access) is brought to you for free and open access by STARS. It has been accepted for inclusion in Electronic Theses and Dissertations, 2004-2019 by an authorized administrator of STARS. For more information, please contact STARS@ucf.edu.

STARS Citation

Agrawal, Pankaj M., "Expression Of Trichoderma Reesei Beta]-mannanase In Tobacco Chloroplasts And Its Utilization In Lignocellulosic Woody Biomass Hydrolysis" (2011). *Electronic Theses and Dissertations, 2004-2019*. 1818.

<https://stars.library.ucf.edu/etd/1818>

**EXPRESSION OF TRICHODERMA REESEI β -MANNANASE IN TOBACCO
CHLOROPLASTS AND ITS UTILIZATION IN LIGNOCELLULOSIC BIOMASS
HYDROLYSIS**

by

PANKAJ M. AGRAWAL

M.S. Biotechnology, Dr.B.A.M.University, Aurangabad, India, 2008.

A thesis submitted in partial fulfillment of the requirements
for the degree of Master of Science
in the Burnett School of Biomedical Sciences
in the College of Medicine
at the University of Central Florida
Orlando, Florida

Fall Term
2011

© 2011 Pankaj Agrawal

ABSTRACT

Lignocellulosic ethanol offers a promising alternative to conventional fossil fuels. One among the major limitations in the lignocellulosic biomass hydrolysis is unavailability of efficient and environmentally biomass degrading technologies. Plant-based production of these enzymes on large scale offers a cost effective solution. Cellulases, hemicellulases including mannanases and other accessory enzymes are required for conversion of lignocellulosic biomass into fermentable sugars. β -mannanase catalyzes endo-hydrolysis of the mannan backbone, a major constituent of woody biomass. In this study, *man1* gene encoding β -mannanase was isolated from *Trichoderma reesei* and expressed via the chloroplast genome. PCR and Southern hybridization analysis confirmed the site-specific transgene integration into the tobacco chloroplast genomes and homoplasmy. Transplastomic plants were fertile and set viable seeds. Germination of seeds showed inheritance of transgenes into the progeny without Mendelian segregation. Expression of the endo- β -mannanase gene for the first time in plants facilitated its characterization for use in enhanced lignocellulosic biomass hydrolysis. Gel diffusion assay for endo- β -mannanase showed the zone of clearance confirming functionality of chloroplast-derived mannanase. Endo- β -mannanase expression levels reached up to 25 units per gram of leaf (fresh weight). Chloroplast-derived mannanase had higher temperature stability (40 °C to 70 °C) and wider pH optima (pH 3.0 to 7.0) than *E.coli* enzyme extracts. Plant crude extracts showed 6-7 fold

higher enzyme activity than *E.coli* extracts due to the formation of disulfide bonds in chloroplasts, thereby facilitating their direct utilization in enzyme cocktails without any purification. Chloroplast-derived mannanase when added to the enzyme cocktail containing a combination of different enzymes yielded 20% more glucose equivalents from pinewood than the cocktail without mannanase. Our results demonstrate that chloroplast-derived mannanase is an important component of enzymatic cocktail for woody biomass hydrolysis and should provide a cost-effective solution for its diverse applications in the paper, oil, pharmaceutical, coffee and detergent industries.

ACKNOWLEDGMENTS

First of all I would like to thank Dr. Henry Daniell for providing me this great opportunity to do my thesis research in his lab. I would like to thank the committee members Dr. Papachan Kollatukudy and Dr. William Self for being on my committee and for the helpful suggestions. I thank Dr. Dheeraj Verma for creating the chloroplast transformation vector and for the continuous motivation in the lab work. I also thank Dr. Nameirakpam Dolendro Singh for his assistance and helpful tips on the plant tissue culture work. I want to thank all my family members who always supported me and have been a continuous source of motivation. I would also like to thank all my friends and lab colleagues.

TABLE OF CONTENTS

LIST OF FIGURES.....	viii
LIST OF ACRONYMS/ABBREVIATIONS	ix
INTRODUCTION.....	1
MATERIALS AND METHODS	7
Construction of pLD man1 chloroplast vector	7
Sterilization and germination of seeds	7
Bombardment of tobacco leaves with pLD man1 vector	8
Preparation of gold particles suspension	8
Coating of plasmid DNA on gold particles: (For 5 shots)	9
Bombardment of pLD man1 vector	9
Preparation of tissue culture media.....	10
Tissue regeneration and selection	10
Transfer of shoots to autotrophic environment.....	11
Extraction of genomic DNA.....	11
Polymerase chain reaction.....	12
Southern Blot Analysis.....	14
Restriction digestion of genomic DNA	14
Agarose gel electrophoresis and DNA transfer.....	14
Preparation of Probe DNA	15
Labeling of Probe DNA with ³² P.....	16

Prehybridization and hybridization of membrane with labeled Probe	17
Autoradiography of the membrane	17
Extraction of protein from <i>E.coli</i> pLD man1	18
Extraction of protein from man1 plant leaf	19
Quantification of total soluble protein by Bradford assay	19
Gel Diffusion assay for Mannanase activity	20
Determination of optimal substrate concentration, pH and temperature for mannanase activity	21
Mannanase enzyme activity assay	21
Hydrolysis of pinewood with chloroplast-derived enzymes	22
RESULTS.....	24
Construction of chloroplast transformation vector harboring <i>man1</i> gene	24
Regeneration of transformants and evaluation of site specific integration by PCR....	25
Confirmation of Homoplasmy by southern blot analysis	27
Phenotypic evaluation of mannanase plants.....	29
Evaluation of mannanase enzyme activity by gel diffusion assay	31
Characterization of chloroplast-derived and <i>E.coli</i> -derived mannanase	33
Enzyme cocktail for hydrolysis of pinewood.....	37
Maternal inheritance in transplastomic mannanase plants	39
DISCUSSION.....	40
REFERENCES.....	45

LIST OF FIGURES

Figure 1: Schematic representation of chloroplast transformation cassette	24
Figure 2: Regeneration of transplastomic mannanase plants	26
Figure 3: PCR analysis of the transformants	26
Figure 4: Southern blot analysis of transplastomic plants	28
Figure 5: Phenotype of transplastomic mannanase plants	30
Figure 6: Gel diffusion assay for mannanase activity	32
Figure 7: Characterization of chloroplast-derived mannanase	36
Figure 8: Enzyme cocktail for pinewood hydrolysis	38
Figure 9: Evaluation of maternal inheritance in transplastomic mannanase plants	39

LIST OF ACRONYMS/ABBREVIATIONS

aadA- Aminoglycoside 3' adenosyltransferase

BSA- Bovin serum albumin

CBM- Carbohydrate binding module

cpMan- Chloroplast derived mannanase

dCTP- Deoxycytidine triphosphate

DNA- Deoxyribonucleic acid

DNS- Dinitro salicylic acid

dNTP- Deoxyribonucleotides

man1- Mannanase

MS- Murashige and Skoog

PCR- Polymerase chain reaction

rMan- *E.coli* derived mannanase

RMOP- Regeneration media of plants

SDS- Sodium dodecyl sulfate

SSC-Sodium chloride and sodium citrate solution

TSP- Total soluble protein

INTRODUCTION

The world's energy demands are ever increasing and cannot be sustained by conventional fuel sources alone. Therefore, biofuels are needed as an alternative source of energy. The current production of fuel grade ethanol utilizes food crops such as corn grain, which consumes about 25% of U.S corn production and therefore competes with food source [1,2, http://www1.eere.energy.gov/biomass/pdfs/us_biofuels_industry_report.pdf].

Lignocellulosic biomass is a renewable alternative source for bioethanol production, which includes agricultural wastes such as pinewood, citrus peel, corn stover, poplar waste, bagasse and rice straw. Currently, large amount of these biomass feed stocks are available for their conversion to fermentable sugars for bioethanol production (United States Department of Energy, http://www1.eere.energy.gov/biomass/feedstock_databases.html). Lignocellulosic

biomass is rich in cellulose and hemicellulose which are difficult to breakdown into fermentable sugars due to the complex structure of the cell wall. For breakdown of complex biomass, chemical and physical pretreatments of these materials are necessary. These treatments are expensive, have serious environmental consequences and impact enzymatic hydrolysis [3]. To reduce such environmental effects of pretreatments, a cost effective and environmentally friendly solution should be considered. As the cellulosic biomass is composed of complex cellulose, hemicellulose and various entangled fibers, concurrent action of different enzyme classes such as

cellulases, glucosidases, hemicellulases and accessory enzymes including esterases, lipases, pectate lyases etc. are required, in large quantities [3]. Simultaneous action of these enzymes can increase the access of each enzyme to the cellulosic biomass.

Hemicelluloses are complex polysaccharides present in plant cell wall and mannans are important constituents of hemicellulosic fraction, which are abundantly present as glucomannan or galactoglucomannan in the wood of gymnosperm plants [4]. Wood dry mass contains 20-25% of galactoglucomannan and is the main component of softwood hemicellulose. It is composed of a linear chain of D-mannopyranose and D-glucopyranose units linked by β -(1, 4) glycosidic bonds. The glucose and mannose in the linear chain are partially substituted by α -D-galactopyranosyl units via α -(1, 6) bonds. On the other hand glucomannans constitutes approximately 5% of the secondary cell wall of hardwood [5, 6]. Lignocellulosic biomass rich in mannans include softwood from gymnosperms such as pinewood (10%), poplar wood (4%), and cellulose sludge (4%) (United States Department of Energy, (http://www1.eere.energy.gov/biomass/feedstock_databases.html)). Algae including *Acetabularia* and *Porphyra* contain up to 20% mannans in their cell wall [7, 8] which can be utilized for ethanol production [9]. Algae are also important producers of biodiesel, after the lipids are extracted for biodiesel production; the remaining waste is rich in carbohydrates and can be used as a substrate for bioethanol production [9].

Endo β mannanase (3.2.1.78) belongs to glycoside hydrolase enzyme family 5, which randomly cleaves β -D-1, 4-mannopyranosyl linkage in the main chain of mannans and heteromannans including galactomannans, glucomannans and

galactoglucomannans. The main hydrolysis products obtained by the action of endo β mannanase are mannobiose and mannotriose [10-12]. Mannanases have diverse industrial applications including bleaching of the softwood pulp in paper industry, reducing the viscosity of coffee extracts rich in mannans, oil extraction of coconut meat, oil and gas well stimulation, as a stain removal agent in detergents, nutraceutical and excipient production in the pharmaceutical industry [10,12]. Recently, mannanases have gained importance for their role in hydrolysis of the hemicellulose fraction in the lignocellulosic biomass for efficient breakdown of the complex polysaccharides into simple sugars for bioethanol production [13]. Endo β mannanase is one among the most important hemicellulases for hydrolysis of lignocellulosic biomass. Analysis of a range of enzyme combinations on palm kernel press cake (PKC) showed that including cellulases in combination with mannanase significantly improved ethanol yields up to 70g/kg of PKC [13]. An optimal enzyme cocktail for the hydrolysis of AFEX (ammonia fiber expansion) treated DDGS (dried distillers grains with solubles) has been reported to contain high amount of mannanase. As DDGS consists of 2.5% mannans, including excess of mannanase resulted in the efficient hydrolysis of DDGS and thereby increasing glucose yields [14]. Another study demonstrated that adding chimeric *Aspergillus niger* mannanase to the hydrolysis enzyme cocktail of *Trichoderma reesei* enzyme improved hydrolysis of lignocellulosic substrate softwood [6].

Several organisms including bacteria, actinomycetes, yeast and fungi have been reported to hydrolyze mannans. Among bacteria, Bacillus is the most established mannanase producing group and has been extensively studied [10,15]. The most

utilized fungus in the industrial production of mannanase with immense capability to act on a variety of mannan substrates belongs to genera *Trichoderma* and *Aspergillus* [10,16,17]. *Trichoderma reesei* is one of the most comprehensively studied filamentous fungus which produces industrially important cellulases and hemicellulases. Endo β mannanase from *Trichoderma reesei* has been isolated, purified and characterized [16, 18, 19]. The three dimensional structure of *Trichoderma reesei* mannanase has been elucidated and reveals the presence of four disulfide bonds. Further, additional substrate binding subsites were discovered which are absent in the bacterial enzyme [20]. In another study, *Trichoderma reesei* mannanase successfully hydrolyzed galactomannan in pine kraft pulp, whereas mannanase from *Bacillus subtilis* was not able to do so [21-23]. Sequence alignment and hydrophobic cluster analysis have shown that mannanase from *T. reesei* consists of two modules. One is the N-terminal catalytic module and another is a C-terminal carbohydrate binding module (CBM) [19, 24]. CBM brings the enzyme in close vicinity of the polysaccharide substrate and hence increases the concentration of enzyme at the substrate [25]. A *Trichoderma reesei* mannanase mutant lacking the CBM showed five-fold less hydrolysis of ivory nut mannan when compared to mannanase with CBM [24].

Heterologous expression of both fungal and bacterial mannanase has been used for the production of enzyme via submerged fermentation. Because of the need for prohibitively expensive infrastructure needed for prevention of cross contamination by other microbes, high production cost and limited capability of fermentation facilities for producing various biomass hydrolyzing enzymes, in planta expression of these

enzymes should be preferred. In planta expression of cell wall degrading enzymes have many advantages over other heterologous production systems including remarkable ability of scale up, well established large scale production and harvesting methods, increased enzyme yield/stability and various storage alternatives [26,27] . Tobacco is a suitable host for in planta production of cell wall degrading enzymes because it produces large amount of biomass. The commercial tobacco cultivars yield as much as 40 metric tons of biomass per year in three harvests [28]. Advantages of expressing biomass hydrolyzing enzymes via the chloroplast genome include high levels of expression due to thousands of copies of transgenes in each cell, containment of transgenes via maternal inheritance and minimal pleiotropic effects due to compartmentalization of enzymes within chloroplasts, away from the cell wall.

Several reports have investigated the heterologous production of biomass degrading enzymes in plants via nuclear transformation [29, 30]. Production of enzymes through nuclear transformation has several limitations including low expression levels, gene silencing and position effect [31]. On the contrary, plastid transformation has the ability to accumulate large amounts of foreign proteins (up to 72% levels of total leaf protein) [32, 33]. Engineering foreign genes in the chloroplast genome may provide containment from pollen transmission as organelle genes are maternally inherited in most crops [34]. In addition, harvesting leaves before flowering provides nearly complete transgene containment [31, 34]. Transgene integration into the chloroplast genome occurs by site specific homologous recombination; therefore there is no gene silencing or position effect [31]. Proper protein folding and disulfide bond formation

occurs in chloroplast; hence the expressed protein is properly folded and fully functional [35-38]. Also, compartmentalization within chloroplasts minimizes negative pleiotropic effects of cell wall hydrolyzing enzymes [39] or even increases biomass [40] except in one report where expression of biomass degrading enzyme had drastic phenotypic effect on the transplastomic plants [41]. Moreover, cost of production of enzymes in tobacco chloroplasts is significantly reduced. A recent study showed that about 64 million units of pectate lyase and 10,751 million units of endoglucanase can be produced per year per acre of tobacco, therefore, enzyme production cost was reported to be 3100 and 1480 fold less when compared to their commercial counterparts produced via fermentation [42]. Recent NC State University Tobacco Guide 2011 estimates the cost of production of tobacco as \$3169/acre.

A chloroplast-derived enzyme cocktail has been formulated for the hydrolysis of lignocellulosic biomass based on its composition [42] but did not contain mannanase which is an integral part of an enzyme cocktail for biomass hydrolysis [14]. Woody biomass including pinewood and algal biomass consists of significant amount of mannans. Therefore, in this study *man1* gene from *Trichoderma reesei* was expressed into tobacco chloroplasts. The chloroplast-derived mannanase was characterized and used to formulate an enzyme cocktail for pinewood hydrolysis. Use of mannanase in enzyme cocktail released 20% more fermentable sugars from pinewood than the cocktail without mannanase. To our knowledge, this is the first report of expression of fungal mannanase in plants and their direct utilization in enzyme cocktails, without any need of purification for lignocellulosic biomass hydrolysis.

MATERIALS AND METHODS

Construction of pLD man1 chloroplast vector

The man1 chloroplast vector was constructed by Dr. Dheeraj Verma in Dr. Daniell's lab which is based on the pLD vector developed in Dr. Daniell's lab. *Trichoderma reesei* genomic DNA was obtained from ATCC and used as template for the amplification of three exons of mannanase gene (L25310) using sequence specific primers. Full length cDNA of mannanase was amplified from the exons by a PCR based method [43] using the forward of first exon flanked by *NdeI* restriction site and reverse of third exon flanked by *XbaI* restriction site. Full length amplified product was ligated to pCR Blunt II Topo vector (Invitrogen) and checked for any PCR errors by DNA sequencing (Genewiz). Mannanase coding sequence was excised from Topo vector by double digestion with *NdeI* and *XbaI* and inserted into the pLD vector [36,42,44] to create the tobacco chloroplast expression vector. The final clone was designated as pLD-man1.

Sterilization and germination of seeds

15-20 seeds of wild type tobacco var. *Petit Havana* were taken in an eppendorf tube. They were first washed with 70% ethanol for 1 minute and then surface sterilized with 0.3% of sodium hypochloride 0.1% Tween-20 for 10 minute. To remove the excess

of sodium hypochloride the seeds were washed with sterilized distilled water for 5-6 times. The sterilized seeds were then placed on a filter paper for drying. After drying the seeds were placed on plates containing half strength MS (Murashige and Skoog) media. After the seedlings were germinated within 10 days they were transferred to magenta boxes containing half strength MS media. 2-3 weeks old plants at 3-4 leaf stage were selected and leaves were used for Bombardment.

Bombardment of tobacco leaves with pLD man1 vector

Preparation of gold particles suspension

In an eppendorf tube 50 mg of gold particles (0.6 μ m size) were taken and 1 ml of 100% ethanol was added. The mixture was vortexed for 2 minutes. Then the mixture was centrifuged for 3 minutes at maximum speed (table centrifuge). Supernatant was discarded and 1 ml of 70% ethanol was added and mixture was vortexed for 1 minute. The eppendorf tube was incubated at room temperature with intermittent vortexing. The mixture was then centrifuged at maximum speed for 2 minutes. The supernatant was discarded and to the pellet 1 ml of sterile distilled water was added and washed by centrifuging at max speed. This washing step was repeated 3 times. The gold particles were resuspended in 1ml of 50% glycerol solution and the mixture is stored in -20⁰ C [44].

Coating of plasmid DNA on gold particles: (For 5 shots)

All the further steps were carried on ice. 50 µl of gold particle suspension was taken in a siliconised eppendorf tube. 5µl of plasmid pLD man1 DNA (1 µg/µl) was added while vortexing. 50µl of 2.5M CaCl₂ and 20 µl of 0.1M Spermidine was added to the mixture while vortexing. This mixture was kept for vortexing at 4⁰ C for 15-20 minutes. The mixture was then centrifuged at 4000 rpm for 90 seconds. Supernatant was discarded and the pellet was washed with 200 µl of 70% ethanol. After this the pellet was washed with absolute ethanol 2-3 times. Finally the pellet was suspended in 50 µl of absolute ethanol [44].

Bombardment of pLD man1 vector

Bombardment of pLDman1 vector was done using Biorad PDS-1000 gene gun. All the equipments of the gene gun stopping screens, macro carriers, holders, rupture discs were sterilized prior to use with 70% alcohol. The macro carriers were placed on the holders and 10 µl of the gold particle suspension was loaded on the macro carrier for each shot. The gene gun and the vacuum pump were turned on, the helium tank was turned to the open positions and the valve is turned on till the pressure reaches 1500 psi. The WT tobacco leaf (abaxial side) is placed on RMOP plate on a distance of 9 cm. The vacuum in the gene gun was allowed to reach 28 psi and then it was hold and fired (the fire switch was hold until the rupture disc was burst on 1100 psi). After the

bombardment, vacuum was released and plate was removed and was covered in a foil and incubated in dark for 48 hours [44].

Preparation of tissue culture media

Regeneration media (RMOP) for tobacco was prepared in deionised water, for 1 liter 30g sucrose, one packet of MS salts, 100 mg of myoinositol, 1mg of Benzylaminopurine , 0.1mg of Naphthalene acetic acid, 1mg of thymine hydrochloride. The pH was adjusted to 5.8 using 1N NaOH. 6g per liter of Phytoblend (Cassion Laboratories), was added, the media was autoclaved and poured into plates after cooling. These plates were used during bombardment and for regeneration of shoots (containing spectinomycin 500mg/l) after bombardment. Half strength MS media was made by dissolving one MS packet in 2 liters deionised water with 60g of sucrose, pH 5.8. This media was used to germinate seeds and for rooting of shoots with spectinomycin [44].

Tissue regeneration and selection

After incubation for 48 hours in dark the leaves were cut into small pieces (4-5mm) and placed on RMOP media containing Spectinomycin (500mg/l for *Petit Havana*). The plates were incubated in the culture room with 16 hours of light. After about 4-6 weeks putative shoots were observed. Shoots were allowed to grow on the RMOP media until they were big. Whole genomic DNA was extracted from the shoots

and it was screened for the transgene integration by PCR. PCR confirmed shoots were then cut into pieces and placed on fresh RMOP media containing spectinomycin for second round of selection to attain homoplasmy. After shoots were regenerated from the second round they were placed on half strength MS media containing spectinomycin for rooting. When the shoots were rooted they were again tested for transgene integration by PCR and for confirming homoplasmy southern blot was performed.

Transfer of shoots to autotrophic environment

After the shoots were confirmed for homoplasmy by southern blot the shoots were transferred to Jiffy pellets (soil). They were kept under controlled humidity environment in order to get hardened. The plants are allowed to grow in the incubation room for 8-10 days and they are then transferred to the green house in big pots. All the protein characterization studies were carried out once the plant is in the green house.

Extraction of genomic DNA

Whole plant genomic DNA was extracted using Qiagen DNeasy kit. 100 mg of leaf material was collected aseptically in a 1.7 ml eppendorf tube. The leaf sample was crushed with a glass rod in the eppendorf tube. 400 μ l of lysis buffer AP1 was added to the crushed leaf. 4 μ l of Rnase was added to the mix to degrade RNA. The mixture was vortexed for 10 seconds. The tubes were incubated in 65°C oven for 10 minutes with intermittent gentle mixing. After incubation 130 μ l of buffer AP2 was added and the

tubes were incubated in ice for 5 minutes. The tubes were centrifuged at 14000 rpm for 2 minutes. The supernatant was collected and added to QIAshredder lilac column with the collection tube. The tubes were then centrifuged at 14000 rpm for 2 minutes. The flow through was transferred to a fresh eppendorf tube and 750 µl of buffer AP3 was added to the flow through. The content of the tubes were vortexed. 650 µl of the mix was transferred to the DNeasy mini spin column and centrifuged for 1 minute at 8000 rpm. The flow through was discarded and the remaining mixture from the tube was added to the column and again centrifuged for 1 minute at 8000 rpm. The column was washed with 500 µl wash buffer AW by spinning at 8000 rpm for 1 min. The flow through was discarded and again the step was repeated with spinning at 14000 rpm for 1 minute. Then the tube was centrifuged dry to remove excess of wash buffer. The column was transferred to a fresh eppendorf tube and allowed to dry for about 2-3 minutes. 40 µl of elution buffer EB was added to elute the DNA. The column was centrifuged at 14000 rpm for 2 minutes to elute DNA. DNA was stored at 4 °C and later it was run on 1% gel for confirmation. This DNA was used for PCR and Southern blot.

Polymerase chain reaction

To confirm the site specific integration of the transgene and transgenic cassette into the tobacco chloroplast genome, PCR was performed using the primers 3P-3M and 5P-2M. Genomic DNA was extracted from transgenic plant and PCR reaction was setup using wild type tobacco as negative control and known transplastomic DNA as positive control. For 5P-2M reaction pLD man1 was used as positive control. Primer 3P (5'-

AAAACCCGTCCTCAGTTCGGATTGC–3') is a forward primer which is complimentary to the native chloroplast genome and primer 3M (5'CCGCGTTGTTTCATCAAGCCTTACG-3') is complimentary to the *aadA* gene, this PCR tests for the integration of *aadA* gene. Primer 5P (5'-CTGTAGAAGTCACCATTGTTGTGC-3') acts as the forward primer and is complimentary to the *aadA* gene and 2M (5'-TGACTGCCACCTGAGAGCGGACA-3') acts as reverse primer and is complimentary to the native chloroplast *trnA* gene, this reaction tests for the integration of transgene expression cassette. A typical PCR reaction was 25µl and contained about 0.5 µg of transgenic plant DNA, 10mM dNTP's- 0.75 µl, Primers 3P/5P and 3M/2M- 0.5 µl from 10pmol µl⁻¹ stock, 50mM MgCl₂- 1.25 µl, Mango Taq polymerase- 0.2 µl from stock of 5U µl⁻¹, PCR buffer 5X- 5 µl and deionised water to make up 25 µl [44]. The Polymerase chain reaction was performed using Biorad thermal cycler with the following settings.

Step 1-Denaturation- 94°C for 5 min.

Step 2- 94°C- 1 min.

Step 3- Annealing- 56°C for 1 min.

Step 4- Extension/Elongation- 72°C for 3 min.

Step 5- Go to step 2 – 29 times.

Step 6- Final extension- 72°C for 10 min.

Step 7- 14°C- Forever.

The PCR reaction samples were later run onto 1% agarose gel for observation of bands of specific sizes.

Southern Blot Analysis

Restriction digestion of genomic DNA

Plant genomic DNA from the transgenic shoots was extracted using the Qiagen DNeasy kit as described above. The concentration of DNA was quantified using by reading the absorbance at 260nm and 280nm and equal amount of DNA was used for all the samples. Wild type DNA was used as a negative control. About 5 µg of plant genomic DNA was used for the restriction digestion reaction. In a total reaction volume of 40µl, 4 µl of 10X buffer 3 (New England Biolabs) was used with 1µl of Apa1 enzyme (New England Biolabs) and volume was made up using autoclaved DiH₂O. The reaction was incubated at 25 °C for about 16 hours to achieve maximum digestion of DNA.

Agarose gel electrophoresis and DNA transfer

Next day 6µl of DNA loading dye was added to the restriction digestion reaction and it was loaded onto a 0.8% agarose gel. The gel was allowed to run for about 3 hours on 50V in TAE buffer. After the run was complete the gel was visualized under the gel doc system and a picture was taken alongside a fluorescent ruler to mark the

marker band sizes. The gel was depurinated in 0.25 N HCl for 15 minutes on the rocker. The gel is then washed twice with DiH_2O for 5 minutes each. The gel was then soaked in the transfer buffer (0.4N NaOH and 1M NaCl) for 20 minutes on the rocker. Nylon membrane was cut according to the size of the gel and soaked in transfer buffer for 5 minutes. The transfer was setup on the table with a layer of saran wrap at the bottom. Whatman filter paper cut according to the size of the gel were soaked in transfer buffer and kept at the bottom. Then the gel facing upside down was kept on the filter paper making sure that there were no bubbles. Nylon membrane was kept on the top of the gel. Bubbles if any were removed again. A layer of filter paper soaked in transfer buffer was put above the nylon membrane. Finally a stack of absorbent paper was kept on the top of the filter paper. Weight was put on the top of the paper for efficient capillary transfer of DNA onto the membrane. Parafilm was kept surrounding the whole setup in order to prevent lateral transfer. The setup was left undisturbed overnight for transfer. Next day the membrane was washed with 2X SSC (0.3M NaCl and 0.03M Sodium citrate) twice for 5 minutes each. It was then allowed to dry and then the DNA was cross linked to the membrane with UV Crosslinker at 150mJ (Biorad). The membrane was now ready for prehybridization.

Preparation of Probe DNA

The Flanking probe DNA for chloroplast genome *trnI* and *trnA* was prepared by digesting the pUC-CT vector DNA. Restriction enzymes Bam H1 and Bgl 2 1 μ l each were used in a 30 μ l reaction with 6 μ l of Buffer 3 (New England Biolabs) and 10 μ l of

DNA, the volume was made up by autoclaved deionised H₂O. The digestion reaction is incubated at 37°C for about 1 hour. The digestion reaction is then run on a 0.8% agarose gel in TAE buffer using ficol as the loading dye. The obtained band of 0.8kb is then cut and the DNA is eluted from the gel. Qiagen Gel extraction kit was used to extract DNA from the gel. Manufacturer's protocol was followed. Finally the DNA was eluted in 50µl of deionised H₂O.

Labeling of Probe DNA with ³²P

45µl of probe DNA was taken and it was denatured by boiling it at 95°C for 5 minutes. The tube was then kept on ice for 2 minutes. Tube was spun to bring down the droplets. The probe DNA was added to the tube containing the Ready-to-go DNA labelling beads (GE) and mixed by flicking. To this mix 5µl of ³²P dCTP was added and incubated at 37°C for 1 hour in the radioactive hood. Meanwhile the G50 resin column was resuspended by vortexing, the cap was loosened and the bottom was broken to remove the flow through. The column was centrifuged at 3000 rpm for 1 minute to remove the liquid and the column was transferred to the fresh tube. Now the labeled probe DNA was added to the center of the resin column and centrifuged at 3000 rpm for 2 minutes. The amount of labeled probe DNA (radioactivity) was quantified using the Scintillation counter. For this 2µl of probe DNA was mixed with STE buffer.

Prehybridization and hybridization of membrane with labeled Probe

The membrane was placed into the hybridization bottle making sure that there was no bubble and the top facing inside of the tube. Then 10 ml of Stratagene hybridization solution was added to the tube. The tube was then kept in the Hybridization chamber for 1 hour at 68°C. 100µl of Salmon sperm DNA (10mg/ml) was taken in an eppendorf tube and to this the required amount of radio labeled probe was added . This mix was boiled at 94 °C for 5 minutes. 1 ml of hybridization solution was removed from the bottle and added to the probe. Then this mix was again returned to the hybridization bottle and incubated for 1 hour at 68 °C. After 1 hour the hybridization solution was discarded and the membrane was washed with wash buffer 1 (2x SSC and 0.1% SDS) at room temperature for 15 minutes. This washing step was repeated again for 10 minutes. After the wash the liquid was discarded in the radioactive waste. Wash buffer 2 (0.1x SSC and 0.1% SDS) was now used for washing at 60 °C for 15 minutes. The radioactivity of the membrane was checked using the Geiger counter. The membrane was then allowed to dry and wrapped in saran wrap.

Autoradiography of the membrane

The membrane was kept in the radioactivity development cassette and then taken to the dark room for exposure to the X-ray film. The X-ray film was exposed to the membrane and the cassette was closed in the dark room and covered with the black

bag. The cassette was kept in -80°C freezer for development overnight. Next day the cassette was removed from the freezer and allowed to thaw for 30 minutes. Then the cassette was taken to the dark room for development of the film. The film was developed in the dark room to observe the developed bands of required size.

Extraction of protein from *E.coli* pLD man1

50 ml of LB media was inoculated with 100µl of starter culture of *E.coli* harboring pLD man1 gene. 50µl of ampicillin (50mg/ml) was added to the culture. pLD Utr was also inoculated as a negative control. The culture was incubated at 37°C for about 16 hours. Next day good growth of cells was observed, the media was taken in a tube and it was centrifuged at 8000 rpm for 10 minutes at 4 °C. The pellet of cells was obtained and the supernatant was discarded. The pellet was washed with 50mM Sodium citrate buffer pH 5.0. The pellet was then dissolved in 3 ml of 50mM Sodium citrate buffer pH 5.0 containing protease inhibitor cocktail tablet (Roche). This mixture was then sonicated (Misonix sonicator) 5 times with a pulse of 20V for 30 seconds with an interval of no pulse of 30 seconds. The cells were disrupted by sonication to release the soluble proteins. Sonication was carried on ice. The mixture was then centrifuged at 10000 rpm for 10 minute to separate the supernatant and the pellet. All the steps were carried on ice. The supernatant was used as a crude *E.coli* enzyme.

Extraction of protein from man1 plant leaf

1 gram of leaf from transgenic mannanase plant was obtained and 1 gram from wild type tobacco was used as negative control. The leaf was then ground into fine powder with liquid nitrogen with the help of a mortar and pestle. To this ground plant material 1ml of 50mM sodium citrate buffer pH 5.0 with the protease inhibitor cocktail tablet (Roche) was added. The mixture was vortexed for 10 minutes at 4°C. The mixture was then centrifuged at 10000 rpm for 20 minutes at 4°C to obtain the supernatant which was used as a crude plant enzyme. The enzyme preparation was filtered through 0.22µ syringe filter. This enzyme solution was then concentrated using Millipore 10kd cutoff concentrators by centrifuging it at 3000 rpm at 4°C. This also removed any sugars present in the extract. All the above steps were carried on ice.

Quantification of total soluble protein by Bradford assay

Total soluble protein in the enzyme extract from the plant leaf and from *E.coli* was quantified by Bradford method using the Biorad Protein assay reagent. The reagent was diluted in the ratio of 1:5 with sterile DIH₂O. This was then filtered and sterilized using the syringe filter (Nalgene 0.2µ). Serial dilutions of the enzyme extract were prepared as 1:5, 1:10 and 1:20 with DIH₂O. BSA standards (0.05-1mg/ml) were used to plot a standard curve. 10µl of each dilution were loaded onto a micro titer plate in duplicates along with the BSA standards. 200 µl of the Bradford reagent was then added to the wells to develop the blue color. Absorbance was then read at 595 nm using the Biorad

Plate reader. Protein concentration in the extract was quantified based on the standard curve.

Gel Diffusion assay for Mannanase activity

Gel diffusion assay was performed to evaluate the mannanase activity of chloroplast-derived (cpMan) and E.coli-derived (rMan) using locust bean gum (Sigma G0753). Locust bean gum is galactomannan extracted from seeds of *Cirtonia siliqua*. Locust bean gum (0.1%) was suspended in 50mM sodium citrate buffer pH 5.0 by boiling while constantly stirring. The mixture was centrifuged at 3,000 rpm and the supernatant was collected. Phytigel (0.7% w/v) was dissolved in this mixture by heating. The contents were then poured into plates and were allowed to set. Wells were punctured into the gel plates. Crude enzyme extract cpMan and rMan (100 µg) were added into the wells along with *Aspergillus niger* mannanase (Megazyme) as positive control, whereas protein extract from untransformed plant and E.coli harboring pLD vector (without man1 gene) as negative controls. The plates were incubated at 37 °C for 16 hours. These plates were then shaken gently for 15 minutes after adding Congo red dye (1% w/v) and washed with 1 M NaCl until the wells were transparent [45]. The zone of clearance showing mannanase activity was investigated.

Determination of optimal substrate concentration, pH and temperature for mannanase activity

Optimal substrate concentration was determined by using different concentrations of locust bean gum substrate ranging from 0.1% to 1% in a reaction containing 30 µg TSP of cpMan. The effect of temperature on mannanase activity was investigated by incubating 30 µg TSP of cpMan and rMan with 0.5% locust bean gum (pH 5.0) at different temperatures of 24, 37, 50, 60, 70, 80 °C. For evaluation of the optimal pH, a reaction with 30 µg TSP of cpMan and rMan with 0.5% of substrate was setup in sodium citrate buffer (pH 3.0, 4.0, 5.0 and 6.0), phosphate buffer (pH 7.0 and 8.0) and Tris-HCl buffer (pH 9.0 and 10.0) at 70°C for 2 hours. To determine the stability of cpMan for longer duration, reactions were set with 0.5% substrate containing 30 µg TSP of cpMan at 70 °C for different time points ranging from 30 minutes to 36 hours.

Mannanase enzyme activity assay

Mannanase enzyme activity assay was performed using locust bean gum as substrate. The substrate was suspended in 50mM Sodium citrate buffer pH 5.0 and heated until boiling while stirring continuously. The substrate was cooled and allowed to homogenize while stirring overnight. The insoluble material was removed by centrifugation [16] and supernatant was used as substrate for the reaction. Increasing concentration of total soluble protein (TSP, 10µg to 100 µg) from cpMan and rMan were taken in a 500 µl reaction containing 0.5% locust bean gum substrate in 50mM Sodium

citrate buffer pH 5.0 at 70 °C for 16 hours. BSA (100 µg/ml) was added to all reactions. Protein extract from untransformed plant and E.coli harboring pLD vector (without man1 gene) were used as negative controls. The reducing sugars released after the reaction were quantified by DNS method taking appropriate dilutions of the reaction samples. Absorbance was read at 540 nm and mannose was used as standard to measure the reducing sugars liberated after the reaction [46]. For mannanase unit calculation, carob galactomannan (Megazyme) was used as substrate. Mannanase activity in plants was quantified by comparison with enzyme activity of commercially available mannanase (Megazyme E-BMANN). One unit of mannanase activity is defined as the amount of enzyme which released one micromole of reducing-sugar equivalents per minute from low viscosity carob galactomannan (2 mg/ml, pH 5.0, and 70 °C). All experiments had appropriate controls containing substrate without enzyme or enzyme without substrate.

Hydrolysis of pinewood with chloroplast-derived enzymes

Dried pinewood sample (*Pinus ponderosa*) was obtained from KL Energy Corporation (Rapid City, SD, USA). Pinewood hydrolysis was carried out as described earlier [42]. Crude enzyme extracts obtained from the tobacco plants expressing a variety of biomass degrading enzymes were used to make various formulations of enzyme cocktails for pinewood hydrolysis. Prior to hydrolysis reaction, pinewood biomass was washed several times in distilled water until there was no sugar detected in the sample by DNS method. The hydrolysis reaction was carried out at 40-50 °C for 36 hours in 50 mM sodium citrate buffer (pH 5.0), 5 mM CaCl₂ and 100 µg of BSA per 5

ml reaction containing 200 mg pinewood. Pinewood hydrolysis was done at 50 °C as other enzymes present in the cocktail were more active within the range of 40-60 °C. Mannanase retained most of its activity at 50 °C. The various cocktails were comprised of chloroplast-derived enzymes Mannanase (Man), Xylanase (Xyn gene from *Trichoderma reesei*), Cellulase (CelD gene from *Clostridium thermocellum*), Endoglucanase (Eg1 gene from *Trichoderma reesei*), Exoglucanase (CelO gene from *Clostridium thermocellum*), β glucosidase (Bgl gene from *Trichoderma reesei*), Pectate Lyases (Pel A, B, D genes from *Fusarium solani*), Acetyl xylan esterase (Axe1 gene from *Trichoderma reesei*) and Swollenin (Swo gene from *Trichoderma reesei*) [42]. The enzyme activity (units/mg) in crude total soluble protein of all chloroplast derived enzymes except mannanase was determined in earlier study [42]. In this study, for all cocktails, 200 μ g TSP of each enzyme extract was used whereas negative control reaction contained 2000 μ g TSP of untransformed leaf extract in 5ml of hydrolysis reaction. All the reactions were carried out in a rotary shaker at 150 rpm. End product fermentable sugars were determined by DNS method [46] with D-glucose as standard. The percent hydrolysis of pinewood by different cocktails was calculated based on considering maximum release of fermentable sugars as 100% hydrolysis. The “percent increase” among other cocktails was calculated based on the release of sugars. Ampicillin and kanamycin 100 μ g/ml was supplemented to inhibit any microbial growth during the prolonged hours of enzyme hydrolysis. All experiments were carried out in triplicate and statistical analysis was performed using t-test.

RESULTS

Construction of chloroplast transformation vector harboring *man1* gene

Coding sequence of *man1* gene (three exons) was amplified by PCR [43] from *Trichoderma reesei* genomic DNA. Agarose gel analysis of the final PCR product showed a product of ~1338 bp, which was cloned in pCR Blunt II Topo vector (Invitrogen) and sequence was verified. Tobacco chloroplast transformation vector pLD-*man1* (Figure 1B) was constructed with *man1* coding sequence based on the universal chloroplast vector that targets the transgene expression cassette into the transcriptionally active spacer region between the *trnI* and *trnA* genes (Figure 1A) of the chloroplast genome for integration via homologous recombination [47]. The *man1* gene was driven by light and developmentally regulated *psbA* promoter and 5' UTR, which contains several ribosome binding sites to enhance transgene expression levels [32]. The 3' UTR located at the 3' end of *man1* coding sequence stabilized the transcript. The *aadA* gene conferring spectinomycin resistance for selection of transformants was driven by the constitutive tobacco plastid ribosomal operon promoter (*Prrn*).



Figure 1: Schematic representation of chloroplast transformation cassette: Chloroplast flanking sequences *trnI* and *trnA* used for homologous recombination, *Prrn*, rRNA operon promoter; *aadA*, aminoglycoside 3 adenylyl transferase gene; *PpsbA*, promoter and 5' untranslated region of the *psbA* gene; *man1*, mannanase gene; *tpsba*, 3' untranslated region of the *psbA* gene.

Regeneration of transformants and evaluation of site specific integration by PCR

Six independent shoots (per 10 bombardment) appeared from the leaves placed on the regeneration medium containing spectinomycin within 3-6 weeks after bombardment with pLD-*man1* plasmid DNA coated on gold particles (Figure 2A). PCR analysis using 3P/3M validated the site specific integration of the transgenes into the tobacco chloroplast genome. The 3P primer lands on the native chloroplast genome within the 16S *rRNA* gene upstream of the gene cassette and 3M primer lands on the *aadA* gene which is located within the gene cassette (Figure 3D). PCR reaction with 3P/3M primers generated a 1.65 kb PCR product in transplastomic lines (Figure 3A, Lanes: 3-5), which should be obtained only if site specific integration had occurred. Nuclear transformants, mutants and untransformed plants did not show any PCR product as 3P or 3M primer will not anneal (Figure 3A, Lane: 1). The integration of *aadA* and *man1* genes was verified by using 5P and 2M primer pair for PCR analysis. These primers anneal at different locations within the transgene cassette. The 5P primer anneals to the *aadA* gene whereas 2M primer anneals to the *trnA* coding sequence (Figure 3D). The use of 5P/2M primer pair produced a PCR product of ~3kb in the transplastomic lines and positive control (pLD-*man1*) whereas untransformed plant did not show any product (Figure 3B). PCR reaction with *man1* gene specific primer confirmed the integration of *man1* gene (Figure 3C). After PCR analysis, transplastomic plants were moved to additional two rounds of selection (second and third) to achieve homoplasmy (Figure 2 B & C)

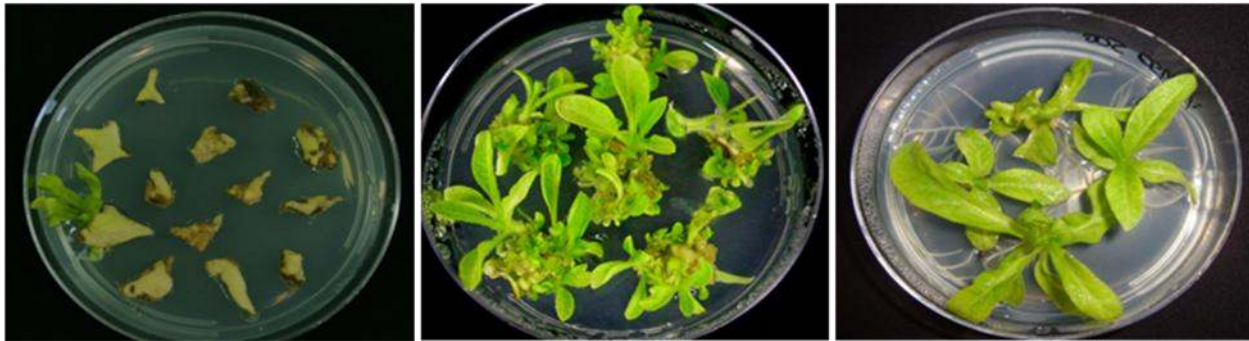

Figure 2: Regeneration of transplastomic mannanase plants: Leaf explants of *Nicotiana tabacum* var Petite Havana bombarded with the chloroplast vector pLD-utr-man1. Spectinomycin (500mg/l) resistant shoots were obtained from the bombarded leaf explants (A). PCR positive shoots were further advanced for second (B) and third (C) round of selection for rooting.

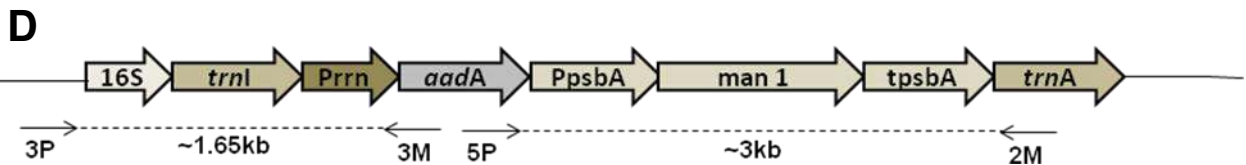
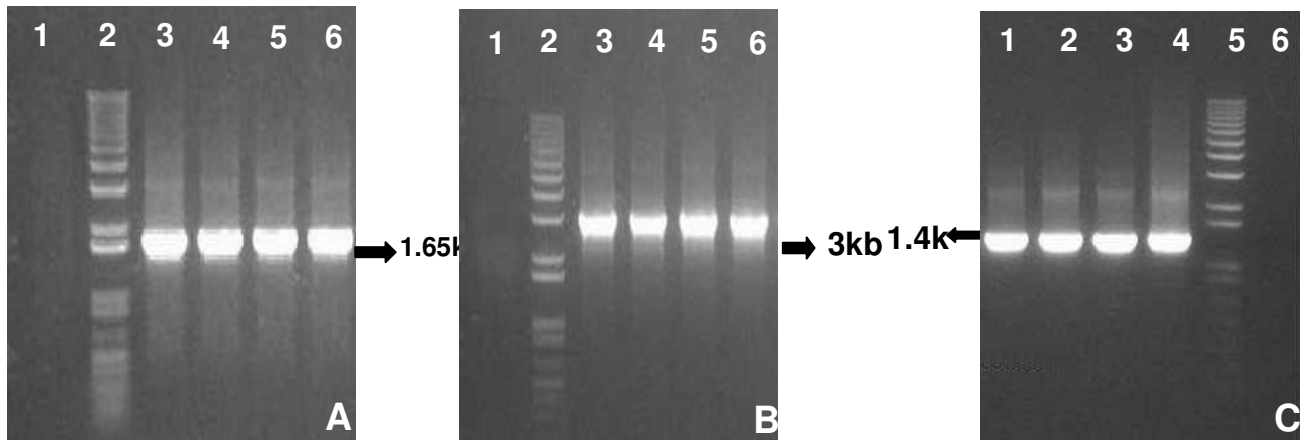

Figure 3: PCR analysis of the transformants: A) PCR reaction with primer 3P-3M produces a band of 1.65kb, Lane 1- Untransformed plant, Lane 2- 1kb+ DNA ladder, Lane 3, 4, 5- transplastomic lines, Lane 6- Positive control. B) PCR reaction with primer 5P-2M shows a band of 3kb, Lane 1- Untransformed plant, Lane 2- 1kb+ ladder, Lane 3, 4, 5- transplastomic lines, Lane 6- Positive control. C) PCR reaction with gene specific primer for man1 gene yields a band of 1.4kb, Lane 1, 2, 3- Transplastomic lines, Lane 4- Positive control, Lane 5- 1kb+ DNA ladder, Lane 6- Untransformed plant. D) Schematic representation of the transgenic cassette and the primer landing sites for 3P-3M and 5P-2M.

Confirmation of Homoplasmy by southern blot analysis

Southern blot analysis was performed to determine homoplasmy and to further confirm the site specific integration. The flanking sequence probe (0.81 kb, Figure 4A) which hybridizes with the *trnI* and *trnA* genes allowed determination of homoplasmy or heteroplasmy and site specific integration of the transgene cassette into the chloroplast genome. Total plant DNA isolated from the transplastomic lines as well as untransformed tobacco plants was digested with *Apal* (Figure 4A and B) and blotted onto nylon membrane. Hybridization of nylon membrane with flanking sequence probe produced fragments of 7.1kb in transplastomic lines (Figure 4B, Lane 1 & 2) and 4.0 kb (Figure 4B, Lane UT) in untransformed plant. Absence of 4kb fragment in transplastomic lines confirmed homoplasmy (within the detection limits of Southern blot) and stable integration of foreign genes into the chloroplast genome whereas the detection of 4kb fragment in untransformed plants confirmed that these plants lacked foreign genes. In addition, the *man1* probe was utilized to verify the presence of *man1* gene which produced a 7.1kb fragment in transplastomic lines (Figure 4C, Lanes 1 & 2). No hybridizing fragment was observed in the untransformed line confirming the absence of the *man1* gene (Figure 4C, Lane UT).

A

Figure 4: Southern blot analysis of transplastomic plants. A) Schematic representation of chloroplast flanking sequences used for homologous recombination, probe DNA sequence (0.81 kb), primer annealing sites (3P/3M and 5P/2M), and expected products of untransformed and transgenic lines, when digested with *Apa*I; *Prn*, rRNA operon promoter; *aadA*, aminoglycoside 3 adenylyl transferase gene; *PpsbA*, promoter and 5' untranslated region of the *psbA* gene; *man1*, mannanase gene; *tpsba*, 3' untranslated region of the *psbA* gene. **B)** Southern blot hybridized with the flanking sequence probe. Lanes 1-2, transplastomic lines; UT, Untransformed. **C)** Southern blot hybridized with *man1* gene specific probe. Lanes 1-2, transplastomic lines; UT, Untransformed.

Phenotypic evaluation of mannanase plants

Homoplasmic lines were transferred to Jiffy pellets and were kept in high humid conditions for 2 weeks before being transferred to the green house to grow under autotrophic conditions. Mannanase transplastomic plants showed mild phenotypic effects with some leaves turning pale as they matured. In spite of this, transplastomic plants grew normally, flowered, set seeds and produced biomass similar to untransformed plants (Figure 5A, 5B).

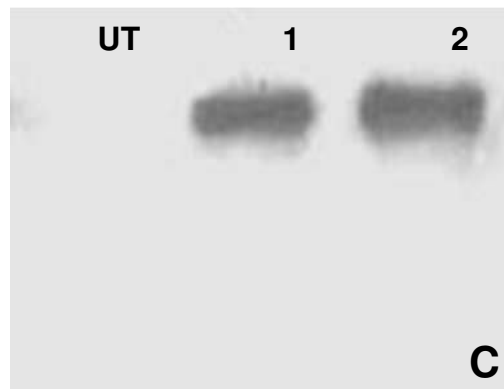
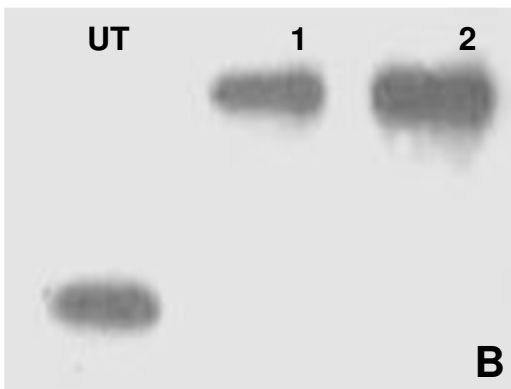
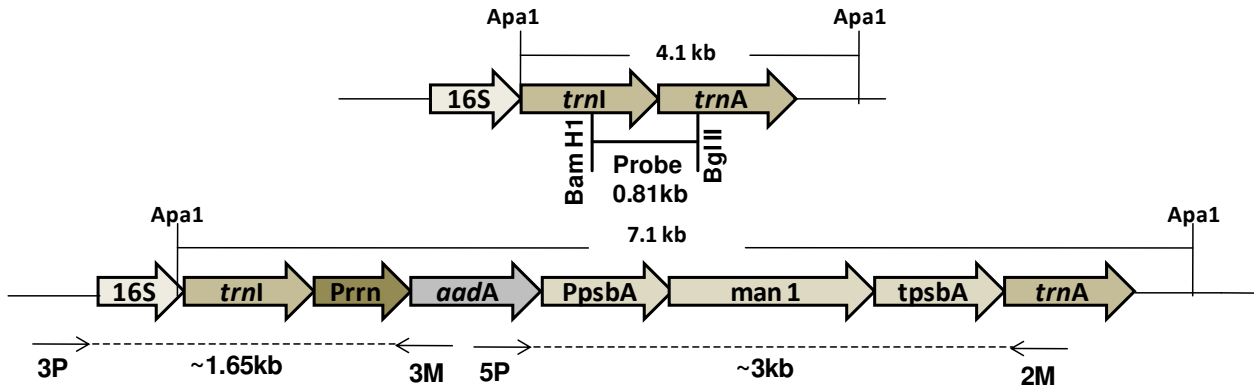
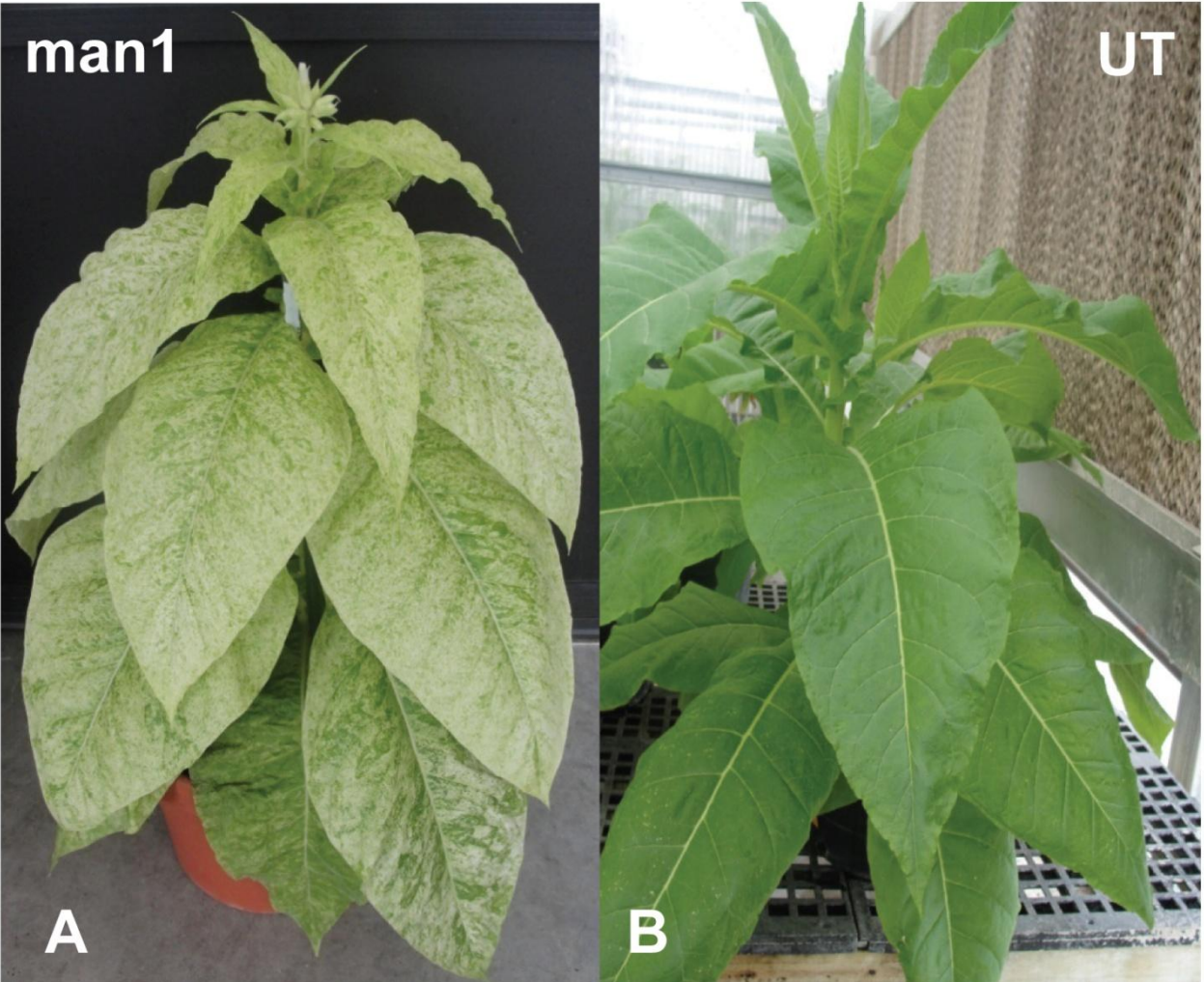

Figure 5: Phenotype of transplastomic mannanase plants. A, Mannanase transplastomic plant growing autotrophically in the green house. Mannanase plants were fertile and set seeds. B, Untransformed (UT) plant

Evaluation of mannanase enzyme activity by gel diffusion assay

Qualitative gel diffusion assay using congo red dye was performed in order to assess the enzyme activity of chloroplast-derived mannanase (cpMan) and E.coli-derived mannanase (rMan). The mannanase enzyme breaks down the polymeric galactomannan substrate, reducing the binding of congo red dye and consequently generates a clearing zone. Both cpMan and rMan showed visible zone of clearance around the wells indicating gel areas hydrolyzed by endo- β -mannanase activity (Figure 6). Mannanase enzyme activity is directly proportional to the diameter of the zone of clearance. Moreover, the diameter of the clearing zone in cpMan was more than rMan when equal amount of protein crude extract (100 μ g) was loaded in these wells indicating that cpMan was more active than rMan. No clearing zone was observed in untransformed plant extract and E.coli harboring pLD vector (without man1 gene, Figure 6). Circular area hydrolyzed by commercial purified mannanase (endo- β -mannanase from *Aspergillus niger*, Megazyme) was also clearly visible surrounding the well. Furthermore, in blank wells without the substrate, none of the extracts showed any clearing zone or non specific activity.

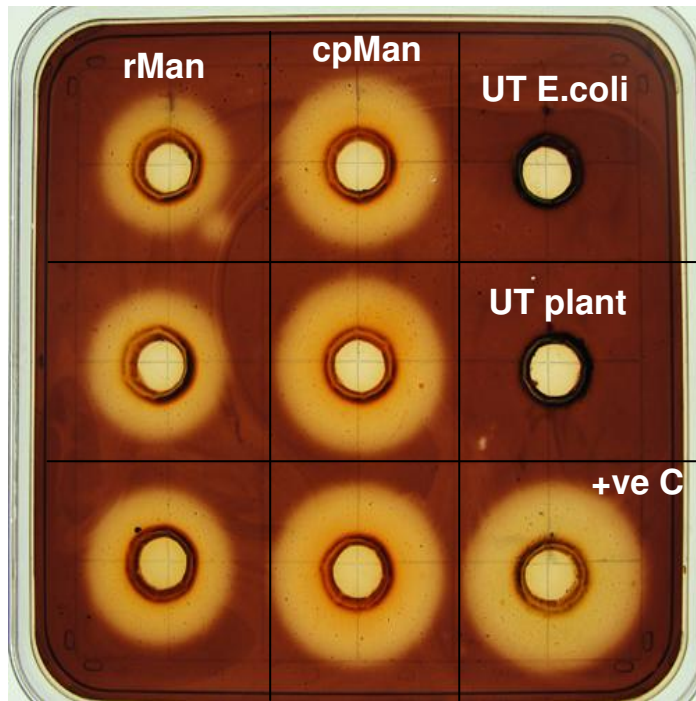

Figure 6: Gel diffusion assay for mannanase activity. Agar plate with 0.1% locust bean gum substrate stained with Congo red dye to evaluate mannanase activity. 100 μ g of rMan, *E.coli*-derived mannanase crude extract; 100 μ g of cpMan, leaf extract from different transplastomic plant lines (Plant 1, 2 & 3); UT *E.coli*, Untransformed *E.coli* extract; UT plant, Untransformed plant extract; +C, purified *Aspergillus niger* mannanase (Megazyme).

Characterization of chloroplast-derived and *E.coli*-derived mannanase

Since chloroplast promoters function efficiently in *E.coli*, crude extract from *E.coli* harboring pLDman1 was used for quantitative comparison of enzyme activity with chloroplast-derived enzyme. Enzyme assays were performed using locust bean gum (galactomannan) as the substrate. Both plant and *E.coli* extract showed optimal activity at 0.5% locust bean gum and reducing sugars increased at a directly proportional rate until this concentration was reached (Figure 7A). Hence, all subsequent enzyme characterization studies were carried out at this substrate concentration. Both cpMan and rMan released more reducing sugars with increasing protein concentration. However, chloroplast-derived mannanase released more reducing sugars at all of the tested total soluble protein (TSP) concentrations when compared to the *E.coli*-derived mannanase (Figure 7B). This data shows that the chloroplast expression system is more efficient up to 6-7 folds higher at 100 µg TSP than the bacterial system. Untransformed plant extract and *E.coli* did not yield any significant amount of reducing sugars under standard assay conditions. The primary purpose of this study was to use the plant crude extract without purification for lignocellulosic biomass hydrolysis in order to make the process cost effective. Time dependent changes in enzyme activity of cpMan showed a linear increase in release of reducing sugars with increasing time. The cpMan continued to increase enzyme activity even up to 36 hours of incubation indicating stability of this enzyme for long durations at 70 °C (Figure 7C).

The primary purpose of this study was to use crude extracts of chloroplast-derived mannanase along with the other chloroplast-derived enzymes in a cocktail for hydrolysis of lignocellulosic biomass. Temperature and pH are important characteristics for efficient use of crude enzyme extracts in cocktails. Crude enzyme extract (30 μ g TSP) from plant and E.coli harboring mannanase expression cassette was used to study the effect of pH and temperature on mannanase activity using the locust bean gum (0.5%) as substrate. The optimal pH for cpMan and rMan under the standard assay conditions was pH 5.0. The pH stability curve showed that cpMan retained >50% of its maximal activity within a broad pH range from pH 3 to pH 7, whereas rMan retained only 42% within this range. However, at pH \geq 8, both cpMan and rMan lost more than 80% of its activity (Figure 7D). These data suggest that mannanase enzyme was more active in the acidic pH range. The optimal temperature for cpMan and rMan was 70 °C under the standard assay conditions. The enzyme activity increased with increase in temperature up to 70 °C in both E.coli and chloroplast-derived mannanase as indicated by the temperature stability curve. Further rise in temperature affected enzyme activity drastically and about 70% of its activity was lost (Figure 7E).

Young, mature and old leaves from transplastomic mannanase plants were collected and mannanase activity was measured using carob galactomannan as the substrate. One unit of mannanase activity is defined as the amount of enzyme which released one micromole of reducing-sugar equivalents per minute from low viscosity carob galactomannan (2 mg/ml) at pH 5.0 and under temperature 70°C. Maximum enzyme activity was observed in mature and old leaves (25 Units/g fresh weight) of

transplastomic mannanase plants, where as young leaves showed 44% less activity (11 Units/g). No mannanase activity was detected in untransformed crude leaf extracts whereas E.coli-derived mannanase had 6-7 folds less activity when compared to chloroplast-derived mannanase at 100 µg TSP. Based on the observed expression levels 2366 units of mannanase can be harvested from each tobacco plant. With 8000 tobacco plants grown in one acre of land, 18 million units of mannanase can be produced per single cutting. Typically with 3 cuttings per year 56 million units of mannanase can be harvested per year. These results were obtained using an experimental variety of tobacco Petite Havana which gives about 2.2 tons biomass of fresh leaves. The commercial cultivar produces 20 times more biomass hence it is expected to provide 20 fold higher enzyme yield.

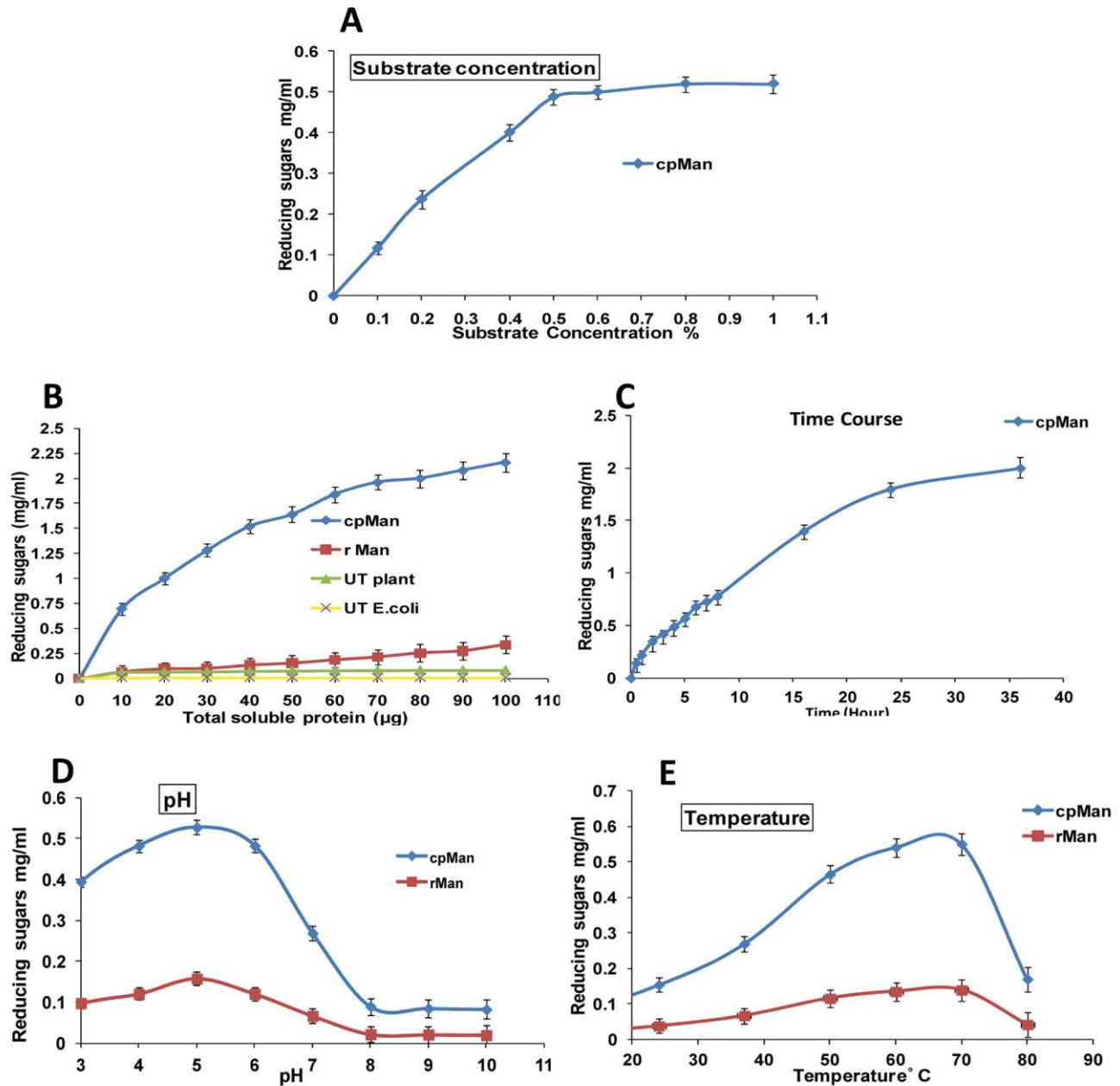

Figure 7: Characterization of chloroplast-derived mannanase. A, Substrate Locust bean gum (0.5%) incubated with crude enzyme extracts in increasing concentrations of total soluble protein at 70 $^{\circ}$ C, pH 5.0 in a reaction for 16 hours. B, Effect of increasing locust bean gum concentration on cpMan activity. C, Effect of incubation time on cpMan activity. D, Effect of pH on cpMan and rMan activity. E, Effect of temperature on cpMan and rMan activity. 30 μ g of total soluble protein was incubated with 0.5% of locust bean gum at indicated reaction parameters for 2 hrs. rMan, *E.coli*-derived mannanase crude extract; cpMan, leaf extract from transplastomic plants; UT *E.coli*, Untransformed *E.coli* extract; UT plant, untransformed plant extract. (Error bars indicates the standard deviation; n=3)

Enzyme cocktail for hydrolysis of pinewood

Chloroplast-derived enzymes were used in different formulations to make various cocktails for hydrolysis of pinewood. Chloroplast-derived mannanase (Man) alone showed 4.4% of the total hydrolysis of pinewood (Figure 8, bar 1). The hydrolysis was further increased up to 14.6% when mannanase was mixed with xylanase (Xyn) and acetyl xylan esterase (Axe; Figure 8, bar 2). When we used Xyn and Axe along with endoglucanases (CelD, Eg1), exoglucanase (CelO) and swollenin (Swo), the hydrolysis increased up to 64.1% (Figure 8, bar 3). Supplementation of Man to this cocktail enhanced the hydrolysis by 11% attaining 70.1% of the total hydrolysis (Figure 8, bar 4). Besides cellulose and hemicellulose, pectin is the core structural component of plant cell wall of woody plants which includes pine trees. Hydrolysis of pectin component should therefore increase the release of fermentable sugars by cellulases and hemicellulases. When we treated pinewood with pectate lyases (PelA, PelB, PelD) followed by supplementation with the enzyme cocktail in bar 3, the overall hydrolysis was extended up to 83.6% (Figure 8, bar 5). Addition of mannanase to this cocktail boosted the hydrolysis to maximum amount resulting in liberation of 20% more glucose equivalents (Figure 8, bar 6). Statistical analysis between cocktails with (Figure 8, bar 4 and 6) and without mannanase (Figure 8, bar 3 and 5) showed significant difference in release of fermentable sugars. Addition of leaf extract from untransformed plants to pinewood did not yield any measurable sugars (Figure 8, bar 7). These results indicate

that mannanase plays a significant role in efficient hydrolysis of pinewood biomass to release fermentable sugars.

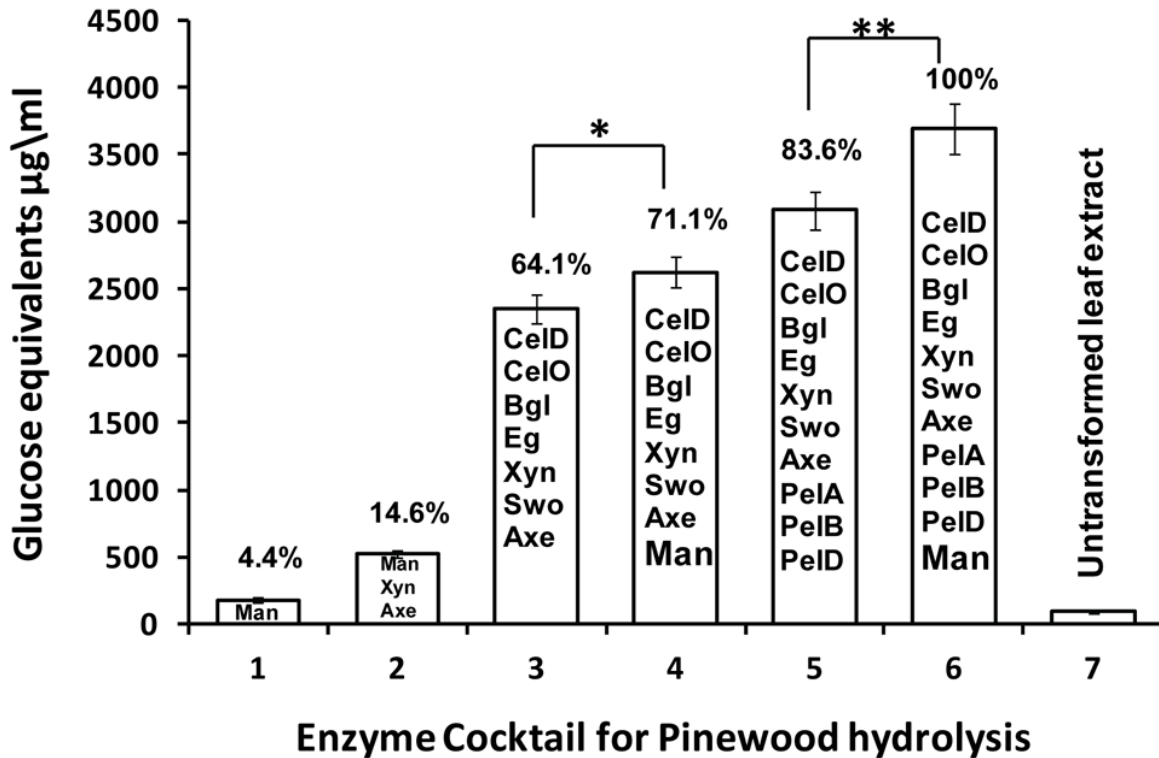

Figure 8: Enzyme cocktail for pinewood hydrolysis. Pinewood (200 mg/5 ml) hydrolysis using different formulations of crude enzyme cocktails. Glucose equivalents released were quantified using DNS method. 200ug TSP of crude chloroplast derived enzyme extracts were used. Man, Mannanase; Xyn, Xylanase; Axe, Acetyl xylan esterase; CelD, Endoglucanase; CelO, Exoglucanase; Bgl, β glucosidase; Eg1, Endoglucanase; Swo, Swollenin; Pel A, B, D, Pectate lyase. (Error bar indicates standard deviation among triplicates, * p value=0.038, ** p value=0.013, p value were calculated using t- test)

Maternal inheritance in transplastomic mannanase plants

Mannanase T1 seeds were germinated along with untransformed seeds on spectinomycin (500mg/l) selection medium. Mannanase seedlings remained green whereas untransformed seeds turned white (Figure 9). These results, observed among several hundred seedlings (only one representative plate shown in Figure 9), indicate that the transgenes were inherited to the progeny without Mendelian segregation.

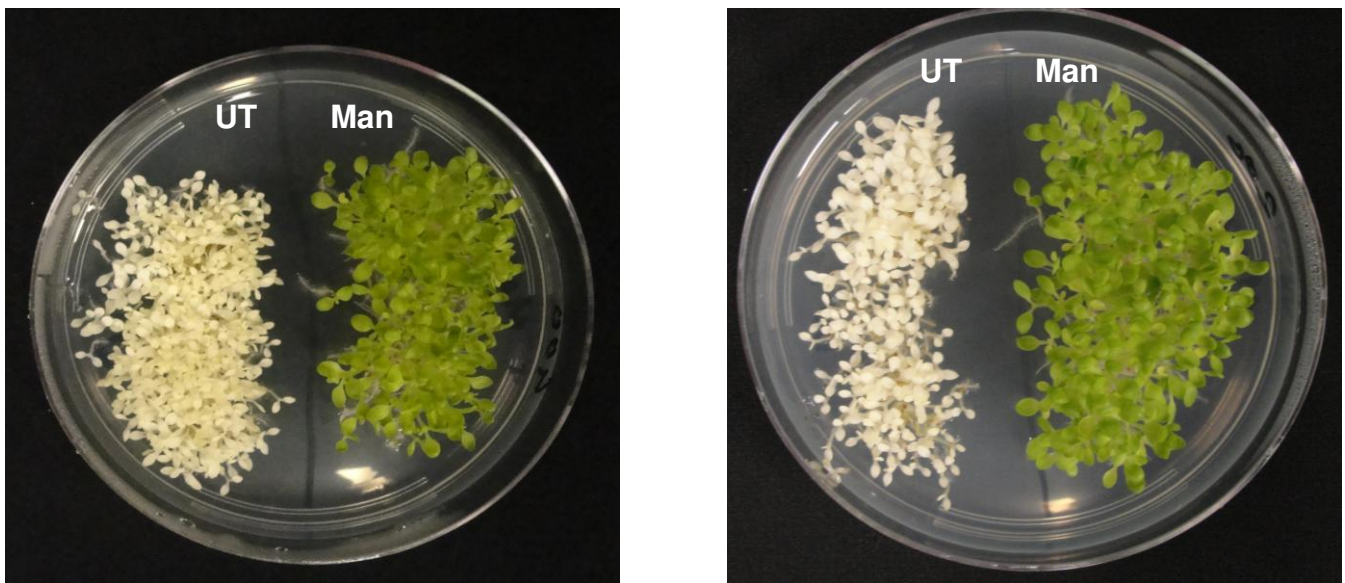

Figure 9: Evaluation of maternal inheritance in transplastomic mannanase plants. Transplastomic (man1) seeds and Untransformed (UT) seeds germinated on MSO medium containing spectinomycin (500 mg/L) showing lack of Mendelian segregation.

DISCUSSION

Lignocellulosic biomass is a heterogeneous complex of different polymers which is composed of intricate intertwined polymers. Therefore, concurrent presence of different classes of cell wall degrading enzymes that can disintegrate biomass and increase the access of each other to the complex structure of biomass is required for the efficient hydrolysis to obtain fermentable sugars. Thus, a mixture of enzymes such as cellulases, hemicellulases including mannanases, ligninases and accessory enzymes like lipases, pectate lyases, esterases may be required depending upon the composition of the biomass [3]. In this study, fungal mannanase was expressed in tobacco chloroplasts. To our knowledge, this is the first report of over expression of fungal mannanase in plants and its direct utilization in enzyme cocktails for lignocellulosic biomass hydrolysis. For production of mannanase, tobacco lines harboring man1 gene from *Trichoderma reesei* were generated. Site specific integration of mannanase gene in chloroplast genome was achieved by using transcriptionally active spacer region between the trnI and trnA genes for homologous recombination. This region has been consistently used for efficient transgene integration and has several unique advantages [32,48,49]. We used the psbA promoter and 5' UTR to achieve high levels of expression. The endogenous psbA regulatory elements have been used for the creation of transplastomic tobacco plants with elevated expression levels for a large number of diverse proteins [32,33,44,50]. The transplastomic mannanase plants exhibited maternal inheritance. In most of the crop species, organelle

genomes are maternally inherited thus excluding plastid integrated transgenes from pollen transmission. During pollen development in tobacco, plastids are unequally distributed localizing all plastids into vegetative cells and excluding generative cells. Hence, sperm cells which originate from generative cells lack plastids [34]. Therefore transplastomic tobacco plants lack Mendelian inheritance. Strict maternal inheritance of transgenes was demonstrated in transplastomic tobacco plants where only 6 out of 2.1 million seedlings showed paternal inheritance with a frequency of 2.86×10^{-6} [51].

Several enzymes have been expressed in chloroplasts for biomass hydrolysis to release fermentable sugars. Most of these enzymes are non-toxic to plant cells because of their compartmentalization within chloroplasts [39,40,42], whereas in one of the report high level expression of cell wall degrading enzymes in tobacco chloroplasts had severe phenotypic effects [41]. The observed phenotype has been attributed to the presence of carbohydrate binding module (CBM) in the cellulolytic enzymes. CBM plays an important role in binding of the enzyme to the carbohydrate substrate. Cellulolytic enzymes when expressed in chloroplasts might cause their deleterious effect by sequestration or degradation of the intermediates of carbohydrate metabolism [41]. We also observed mild phenotypic effects in mannanase transplastomic plants which could be due to the presence of CBM in mannanase. Mannanase from *Trichoderma reesei* has been reported to contain a carbohydrate binding module, which increases its hydrolytic activity [24]. In our study we used the psbA promoter from tobacco for hyper-expression. Use of a heterologous psbA promoter [32] or gene 10 regulatory elements

[31] could lower the expression levels and produce mannanase plants without any phenotypic effects.

Qualitative gel diffusion assay with locust bean gum (galactomannan) substrate using congo red dye showed endo β mannanase activity in crude extracts of transplastomic mannanase plants and E.coli. Similar assay has been used for detection and quantification of endo β mannanase activity present in seeds, fruit, bulbs and fungi [45,52]. Congo red shows high specificity of binding for polysaccharides containing adjacent (1, 4) β -linked D-glucopyranosyl units and galactoglucomannans [53]. Endo mannanase activity lessens the oligomeric length and hence decreases binding of congo red dye. The assay is insensitive for exo-activity and therefore confirms specific endo mannanase activity. The action of mannanase therefore creates a clearing zone which is proportional to the enzyme concentration. This confirms that the crude leaf extract from transplastomic plants contains active mannanase. Since the 3D structure of mannanase consists of disulfide bonds, proper folding of the protein is important for a fully functional enzyme. Chloroplasts have the ability to perform post translational modifications such as disulfide bond formation, assembly of multimers and lipid modifications [36,40-42,48,54-56]. Chloroplast-derived mannanase folded correctly and was fully functional. Lack of disulfide bond formation in E.coli might be the reason for the low activity of mannanase expressed in E.coli when compared to chloroplast-derived enzyme. Also in a recent study, inhibitors were identified in crude E.coli extracts as addition of E.coli crude extract to plant extracts significantly decreased the enzyme activity in the plant extracts [42]

In the current study, 25 units of mannanase were obtained per gram fresh weight of mature leaves harvested at 6PM. Chloroplast-derived mannanase had 6-7 fold higher mannanase activity than E.coli mannanase. Higher activity (up to 24 fold) in chloroplast-derived biomass hydrolysis enzymes (CelO, EG1) when compared to those expressed in E.coli was reported previously [42]. Characterization of chloroplast expressed mannanase showed that the enzyme is biologically as active as the fungal counterpart in the pH range of pH 3.0 to 7.0 with the peak activity at pH 5.0. The optimal temperature for the chloroplast-derived enzyme was 70 °C. Such high temperature appears to be common with fungal β mannanase [16,18,57]. As chloroplast expressed mannanase was functional in crude enzyme extracts derived from mannanase expressing plants, it can be directly added to an enzyme cocktail for biomass hydrolysis without the need for any purification eventually lowering the cost. According to NC state University Tobacco guide 2011, the cost of tobacco cultivation is \$3169 per acre. Based on the observed expression levels of mannanase, about 56 million units of mannanase can be produced per acre per year of tobacco cultivation with the production cost as low as 0.005 cents per enzyme unit (as defined in the commercial source Megazyme). This cost is 6000 fold less when compared with the commercial purified mannanase (Megazyme).

In softwood like pinewood, glucomannans are closely associated with cellulose microfibrils and are integrated into mass of cellulose. These glucomannans are arranged in parallel to cellulose fibrils and are tightly interconnected [6,58]. This structural arrangement could inhibit the access of cellulases to the cellulose fibrils.

Further in a recent study, it was reported that mannan polysaccharides are masked by pectic homogalacturonan (HG) in the primary cell wall and the recognition of mannan epitopes was greatly increased by enzymatic removal of pectic HG by treatment with pectate lyases [59]. Such type of association indicated by the masking of mannans may have a structural role in maintaining primary cell wall integrity. Also, pectic HG may coat mannans and other hemicelluloses, and thus limit or control the access of enzymes to these polysaccharides [59]. Therefore for the efficient breakdown of softwood biomass an enzyme cocktail comprising of mannanase and other cellulolytic enzymes are required. In our study, when mannanase was added to two different cocktails (Figure 5 bar 3 and bar 5) hydrolysis was enhanced significantly (Figure 5 bar 4 and bar 6). This could be due to the hydrolysis of the mannans present in the pinewood resulting in loosening of the structural arrangement and increased access of cellulases, thereby resulting in enhanced glucose release. It is well known that carbohydrate binding module (CBM) binds to the carbohydrate increases the enzyme concentration at the substrate surface and augments the effectiveness of enzyme [25].

Low cost production of mannanase would be highly beneficial for its diverse applications in the paper, oil, pharmaceutical, coffee and detergent industries. Expression of mannanase in plant chloroplasts is an important addition to the list of different cellulolytic enzymes expressed in chloroplast, which significantly enhances the release of fermentable sugars from the lignocellulosic biomass. This study reports the first successful expression of fungal mannanase in plants and its utilization in the release of fermentable sugars for bioethanol production.

REFERENCES

1. Robertson GP, Dale VH, Doering OC, Hamburg SP, Melillo JM, et al. (2008) Sustainable biofuels redux. *Science* 322: 49-50
2. Yang B, Dai Z, Ding S, Wyman CE (2011) Enzymatic hydrolysis of cellulosic biomass, *Biofuels*, 2 (4), 421-450
3. Abramson M, Shoseyov O, Shani Z (2010) Plant cell wall reconstruction toward improved lignocellulosic production and processability. *Plant Science* 178: 61-72
4. Capek P, Kubackova M, Alfoldi J, Bilisics L, Liskova D and Kakoniova D (2000) Galactoglucomannan from the secondary cell wall of *Picea abies* L. *Krast. Carbohydr Res* 329: 635-645
5. Pereira H, Graca J, Rodrigues JC (2003) Wood chemistry in relation to quality. In: Barnett, J.R., Jeronimidis, G. (Eds.), *Wood Quality and Its Biological Basis*. Blackwell Publishing, Oxford, pp. 53-86
6. Pham TA, Berrin JG, Record E, To KA, Sigoillot J (2010) Hydrolysis of softwood by *Aspergillus mannanase*: Role of a carbohydrate-binding module. *J Biotechnol* 148: 163-170
7. JKN Jones (1950) The structure of the mannan present in *Porphyra umbilicalis*. *J. Chem. Soc.* 3292-3295
8. Dunn EK, Shoue DA, Huang X, Kline RE, Mackay AL, et al. (2007) Spectroscopic and biochemical analysis of regions of the cell wall of the unicellular 'mannan-weed', *Acetabularia acetabulum*. *Plant Cell Physiol.* 48(1):122-33

9. Hannon M, Gimpel J, Tran M, Rasala B, Mayfield S. (2010) Biofuels from algae: challenges and potential. *Biofuels* 1(5):763-784
10. Dhawan and Kaur (2007) Microbial mannanases: An overview of production and applications. *Crit Rev Biotechnol* 27: 197-216
11. Moreira LRS and Filho EXF (2008) An overview of mannan structure and mannan-degrading enzyme systems. *Appl Microbiol Biotechnol* 79:165–178
12. Van Zyl WH, Rose S, Trollope K, Gorgens J (2010) Fungal β mannanases: Mannan hydrolysis, heterologous production and biotechnological applications. *Process Biochemistry* 45: 1203-1213
13. Jorgensen H, Sanadi A.R, Felby C, Lange N, Fischer M, et al. (2010) Production of Ethanol and Feed by High Dry Matter Hydrolysis and Fermentation of Palm Kernel Press Cake. *Appl Biochem Biotechnol* 161: 318-332
14. Banerjee G, Car S, Scott-Craig JS, Borrusch M, S, Walton JD (2010) Rapid optimization of enzyme mixtures for deconstruction of diverse pretreatment/biomass feedstock combinations. *Biotechnol Biofuels* 3: 22
15. Sun YM, Yu HY, Wang WJ, Yang YS, Yang YH (2003) Purification and properties of *Bacillus subtilis* SA-22 endo-1, 4-beta-D-mannanase. *Sheng Wu Gong Cheng Xue Bao* 19: 327-330
16. Stalbrand H, Siika-aho M, Tenkanen M, Viikari L (1993) Purification and characterization of two β -mannanases from *Trichoderma reesei*. *J Biotechnol* 29: 229-242

17. Ademark P, Varga A, Medve J, Harjunpaa V, Drakenberg T, et.al ,(1998) Softwood hemicellulose-degrading enzymes from *Aspergillus niger* Purification and properties of a β -mannanase. *J Biotechnol* 63: 199-210
18. Arisan-Atac I, Hodits R, Kristufek D, Kubicek CP (1993) Purification and characterization of a β -mannanase of *Trichoderma reesei* C-30. *Appl Microbiol Biotechnol* 39: 58-62
19. Stalbrand H, Saloheimo A, Vehmaanpera J, Henrissat B, Penttila M (1995) Cloning and expression in *Saccharomyces cerevisiae* of a *Trichoderma reesei* β -mannanase gene containing a cellulose binding domain. *Appl Environ Microbiol* 61: 1090-1097
20. Sabini E, Schubert H, Murshudov G, Wilson K, Siika- Aho M, et al. (2000) The three dimensional structure of a *Trichoderma reesei* b-mannanase from glycoside hydrolase family 5. *Acta Cryst D*56: 3-13
21. Ratto M, Siika-aho M, Buchert J, Valkeajarvi A, Viikari L (1993) Enzymatic hydrolysis of isolated and fibre-bound galactomannans from pine-wood and pine kraft pulp. *Appl Microbiol Biotechnol* 40: 449-454
22. Tenkanen M, Makkonen M, Perttula M, Viikari L, Teleman A (1997) Action of *Trichoderma reesei* mannanase on galactoglucomannan in pine kraft pulp. *J Biotechnol* 57: 191-204
23. Oksanen T, Pere P, Paavilainen L, Buchert J, Viikari L (2000) Treatment of recycled kraft pulps with *Trichoderma reesei* hemicellulases and cellulases. *J Biotechnol* 78: 39-48

24. Hagglund P, Eriksson T, Collen A, Nerinckx W, Claeysens M, et al. (2003) A cellulose-binding module of the *Trichoderma reesei* β -mannanase Man5A increases the mannan-hydrolysis of complex substrates. *J Biotechnol* 101: 37-48
25. Guillen D, Sanchez S & Sanoja R (2010) Carbohydrate-binding domains: multiplicity of biological roles. *Appl Microbiol Biotechnol* 85: 1241-1249
26. Taylor II LE, Dai Z, Decker SR, Brunecky R, Adney WS, Ding SY, Himmel ME (2008) Heterologous expression of glycosyl hydrolases in planta: a new departure for biofuels. *Trends Biotechnol* 26: 413-424
27. M. Sainz (2009) Commercial cellulosic ethanol: the role of plant-expressed enzymes. *In Vitro Cell. Dev. Biol.-Plant*, 45 , pp. 314–329.
28. Cramer, C. L., J. G. Boothe, and K. K. Oishi. 1999. Transgenic plants for therapeutic proteins: linking upstream and down stream strategies. *Curr. Top. Microbiol. Immunol.* 240:95–118.
29. Sticklen MB (2006) Plant genetic engineering to improve biomass characteristics for biofuels *Curr Opin Biotechnol.* 17:315-319.
- 30.. Oraby H, Venkatesh B, Dale B, Ahmad R, Ransom C, Oehmke J, et al. (2007) Enhanced conversion of plant biomass into glucose using transgenic rice-produced endoglucanase for cellulosic ethanol. *Transgenic Res.*16(6):739-49
31. Verma D and Daniell H (2007) Chloroplast vector systems for biotechnology applications. *Plant Physiol* 145: 1129-1143

32. Ruhlman T, Verma D, Samson N, Daniell H (2010) The role of heterologous chloroplast sequence elements in transgene integration and expression. *Plant Physiol* 152: 2088-2104
33. Bally J, Nadai M, Vitel, M, Rolland, A, Dumain, R et al. (2009) Plant physiological adaptations to the massive foreign protein synthesis occurring in recombinant chloroplasts. *Plant Physiol* 150: 1474-1481
34. Daniell, H (2007) Transgene containment by maternal inheritance: effective or elusive? *Proc Natl Acad Sci USA* 104: 6879-6880
35. Bally J, Paget E, Droux M, Job C, Job D (2008) Both the stroma and thylakoid lumen of tobacco chloroplasts are competent for the formation of disulphide bonds in recombinant proteins. *Plant Biotechnol J*.6 (1):46-61
36. Daniell H, Lee SB, Panchal T, Wiebe PO (2001) Expression and assembly of the native cholera toxin B subunit gene as functional oligomers in transgenic tobacco chloroplasts. *J Mol Bio* 311: 1001-1009
37. Staub JM, Garcia B, Graves J, HajdukFiewicz PTJ, Hunter P, et al (2000) High-yield production of a human therapeutic protein in tobacco chloroplasts. *Nat Biotechnol* 18: 333–338
38. Ruhlman T, Ahangari R, Devine A, Samsam M, Daniell H (2007) Expression of cholera toxin B-proinsulin fusion protein in lettuce and tobacco chloroplasts-oral administration protects against development of insulinitis in non-obese diabetic mice. *Plant Biotechnol J* 5: 495-510

39. Ziegelhoffer T, Raasch JA, Austin-Phillips S (2009) Expression of *Acidothermus cellulolyticus* E1 endo- β -1,4-glucanase catalytic domain in transplastomic tobacco. *Plant Biotech J* 7: 527-536
40. Jin S, Kanagaraj A, Verma D, Lange T, Daniell H (2011) Release of hormones from conjugates: chloroplast expression of β -glucosidase results in elevated phytohormone levels associated with significant Increase in biomass and protection from aphids or whiteflies conferred by sucrose esters (2011) *Plant Physiol* 155: 222–235
41. Petersen K, Bock R (2011) High-level expression of a suite of thermostable cell wall-degrading enzymes from the chloroplast genome. *Plant Mol Biol Jul;76(3-5):311-21*
42. Verma D, Kanagaraj A, Shuangxia J, Singh ND, Kolattukudy P, et al. (2010) Chloroplast-derived enzyme cocktails hydrolyse lignocellulosic biomass and release fermentable sugars. *Plant Biotechnol J* 8: 332-350
43. An X, Lu J, Huang J, Zhang B, Liu D, Zhang X, Chen J, Zhou Y, Tong Y (2007) Rapid assembly of multiple-exon cDNA directly from genomic DNA. *PLoS ONE* 2: e1179
44. Verma D, Samson NP, Koya V, Daniell H (2008) A protocol for expression of foreign genes in chloroplasts. *Nat Protoc* 3: 739-758
45. Downie B, Hilhorst H, Bewley D (1994) A new assay for quantifying endo- β -D-mannanase activity using congo red dye. *Phytochemistry* 36: 829-835

46. Miller GL (1959) Use of Dinitrosalicylic acid reagent for determination of reducing sugar. *Anal Chem* 31: 426-42
47. Daniell H, Datta R, Varma S, Gray S, Lee SB (1998) Containment of herbicide resistance through genetic engineering of the chloroplast genome. *Nat Biotechnol* 16: 345-348
48. Daniell H, Ruiz ON, Dhingra A (2004) Chloroplast genetic engineering to improve agronomic traits. *Methods Mol. Biol* 286: 111-138
49. DeCosa B, Moar W, Lee SB, Miller M, Daniell H (2001) Overexpression of the Bt cry2Aa2 operon in chloroplasts leads to formation of insecticidal crystals. *Nat Biotechnol* 19: 71-74
50. Singh ND, Li M, Lee SB, Schnell D and Daniell H (2008) Arabidopsis Tic40 expression in tobacco chloroplasts results in massive proliferation of the inner envelope membrane and upregulation of associated proteins. *Plant Cell* 20: 3405-3417
51. Ruf S, Karcher D, Bock R (2007) Determining the transgene containment level provided by chloroplast transformation. *Proc Natl Acad Sci USA* 104: 6998–7002
52. Still DW, Dahal P, Bradford KJ (1997) A single-seed assay for endo- β -mannanase activity from tomato endosperm and radicle tissues. *Plant Physiol* 113: 13-20
53. Wood PJ (1980) Specificity in the interaction of direct dyes with polysaccharides. *Carbohydr Res* 85: 271-287

54. Arlen PA, Falconer R, Cherukumilli S, Cole A, Cole AM, et al. (2007) Field production and functional evaluation of chloroplast-derived interferon-alpha2b. *Plant Biotechnol J*. 5(4):511-25
55. Glenz K, Bouchon B, Stehle T, Wallich R, Simon MM, Warzecha H (2006) Production of a recombinant bacterial lipoprotein in higher plant chloroplasts. *Nat Biotechnol* 24: 76–77
56. Boyhan D, Daniell H (2011) Low-cost production of proinsulin in tobacco and lettuce chloroplasts for injectable or oral delivery of functional insulin and C-peptide. *Plant Biotechnol J* 9: 585–598
57. Christgau S, Kauppinen S, Vind J, Kofod V, Dalboge H (1994) Expression, cloning, purification and characterization of a beta-1, 4- mannanase from *Aspergillus aculeatus*. *Biochem Mol Biol Int* 33: 917-925
58. Salmen L (2004) Micromechanical understanding of the cell-wall structure. *C R Biol* 327: 873-880
59. Marcus SE, Blake AW, Benians TAS, Lee KJD, Poyser C, et al. (2010) Restricted access of proteins to mannan polysaccharides in intact plant cell walls. *Plant J* 64:191–203