

Portland State University

PDXScholar

Student Research Symposium

Student Research Symposium 2017

May 10th, 11:00 AM - 1:00 PM

Extended Saleh Model for Behavioral Modeling of Envelope Tracking Power Amplifiers

Haider Al Kanan

Portland State University

Fu Li

Portland State University

Felice Francesco Tafuri

Aalborg University

Follow this and additional works at: <https://pdxscholar.library.pdx.edu/studentsymposium>



Part of the [Electrical and Computer Engineering Commons](#)

Let us know how access to this document benefits you.

Al Kanan, Haider; Li, Fu; and Tafuri, Felice Francesco, "Extended Saleh Model for Behavioral Modeling of Envelope Tracking Power Amplifiers" (2017). *Student Research Symposium*. 23.

<https://pdxscholar.library.pdx.edu/studentsymposium/2017/posters/23>

This Poster is brought to you for free and open access. It has been accepted for inclusion in Student Research Symposium by an authorized administrator of PDXScholar. Please contact us if we can make this document more accessible: pdxscholar@pdx.edu.

Extended Saleh Model for Behavioral Modeling Envelope Tracking Power Amplifiers

Haider Al-kanan¹, Fu Li¹, Felice Francesco Tafuri²
¹Portland State University, ²Aalborg University

Introduction

Envelope Tracking (ET) is one of the most deployed efficiency enhancement techniques to improve efficiency of RF Power Amplifiers (PAs) in wireless communication. The problem is that state-of-the-art behavioral models for fixed supply PAs are not accurate enough to model the peculiar distortion effects induced by the time-varying supply regime induced by the ET operation mode.

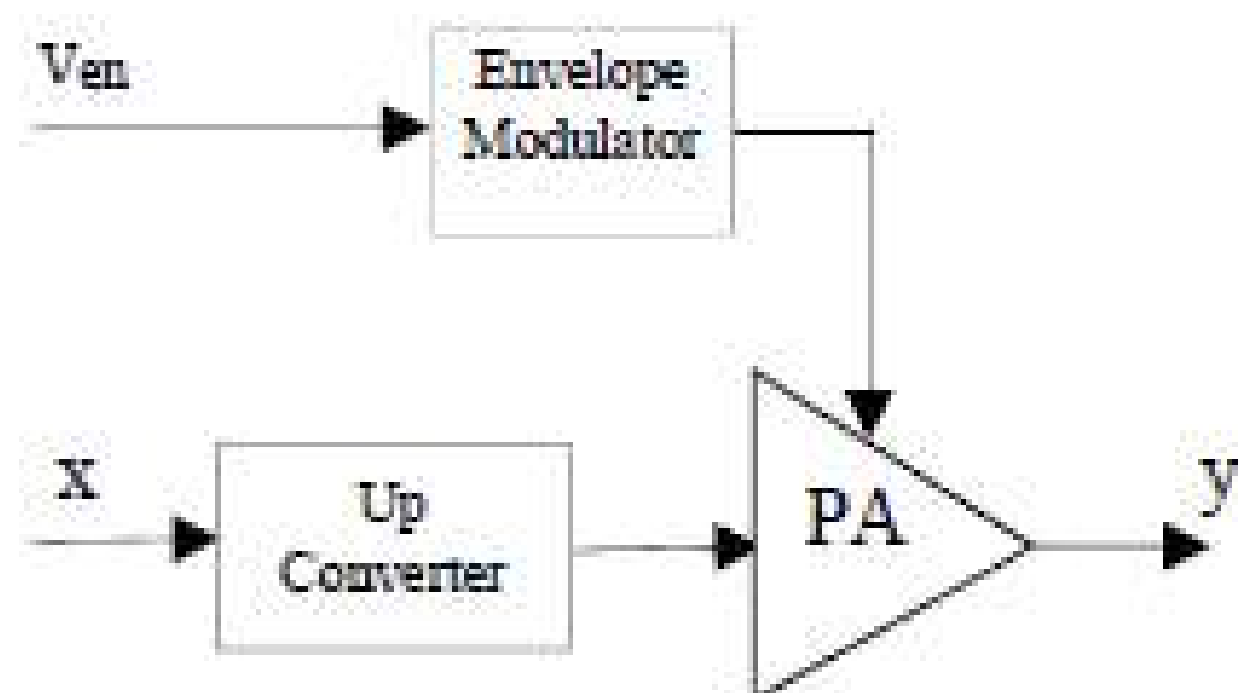

Fig. 1. Simplified block diagram of an equivalent baseband three-port model for ET PAs. V_{en} is the modulated supply voltage obtained by shaping the envelope of the ET PA input baseband signal x .

Objectives

The objectives of this work are:

- Present a new accurate behavioral model for ET PAs
- Include ET-specific dynamic AM/AM and AM/PM distortion effects in the presented model
- A linearization algorithm based on the presented model can be derived to perform digital predistortion of ET PAs

Extended Saleh model

The proposed model extends the Saleh model for fixed supply RF PAs by inserting the modulated supply voltage as an additional model variable (Fig. 1). Memory effects in both AM/AM and AM/PM characteristics are modeled using respectively a Finite Impulse Response (FIR) filter and Taylor polynomial with memory (Fig. 2).

Modeling results

10000 samples of complex baseband input, output, and envelope signals are used for model coefficients extraction. A Least Square Error (LSE) method can be iteratively used for all model coefficient extraction. The modeling accuracy is evaluated in the time domain based on the Normalized Mean Square Error (NMSE), and in the frequency domain based on the Adjacent Channel Error Power Ratio (ACEPR). NMSE and ACEPR versus the nonlinear order and memory depth of the AM/PM Taylor model are depicted in Fig. 4. Fig. 5 – 6 represent the comparison of simulation data and behavioral modeled data in terms of gain, phase deviation and power spectral density for optimal values of the model parameters. The proposed model can mimic ET specific dynamic distortion memory effect as shown in both AM/AM and AM/PM characteristics.

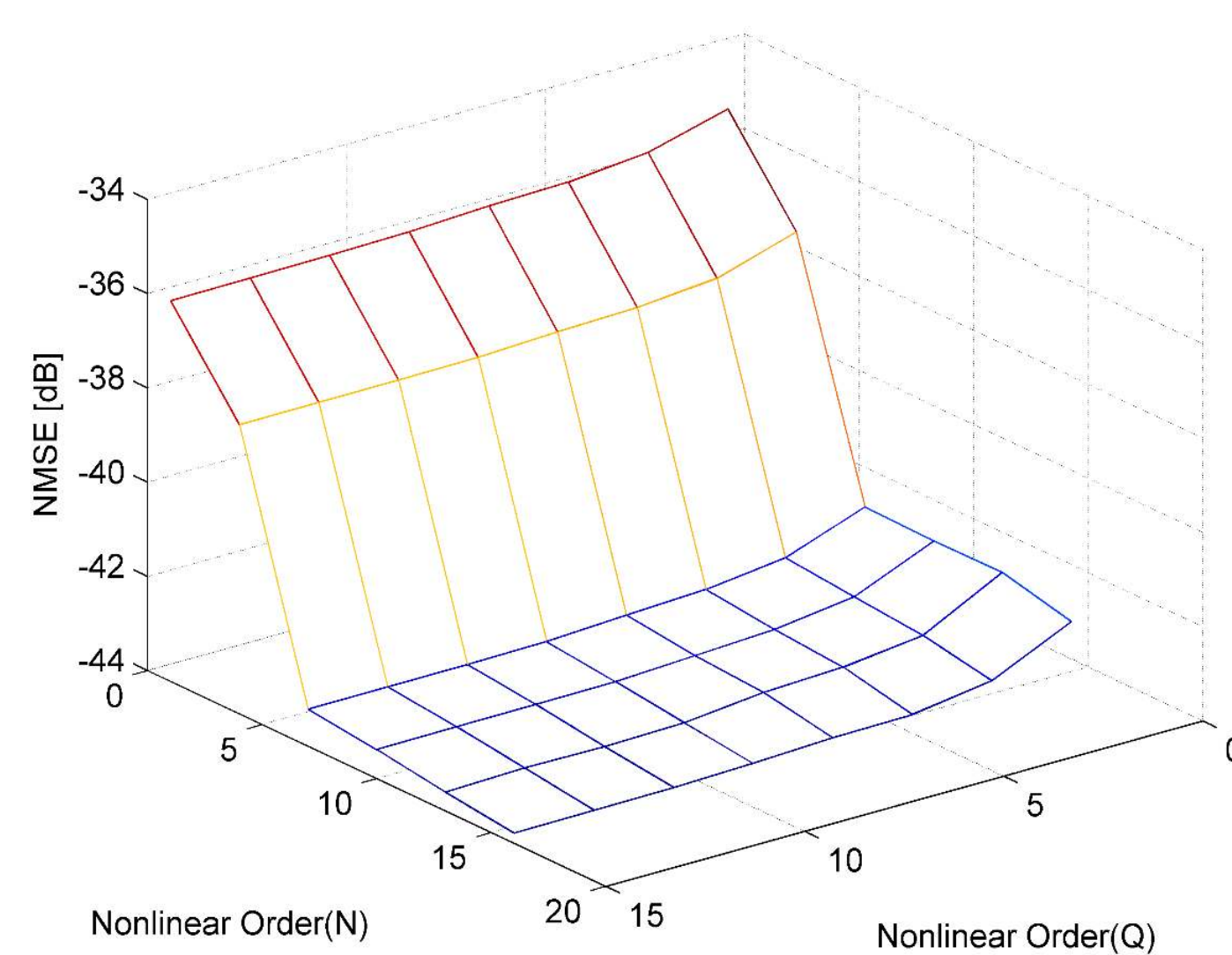
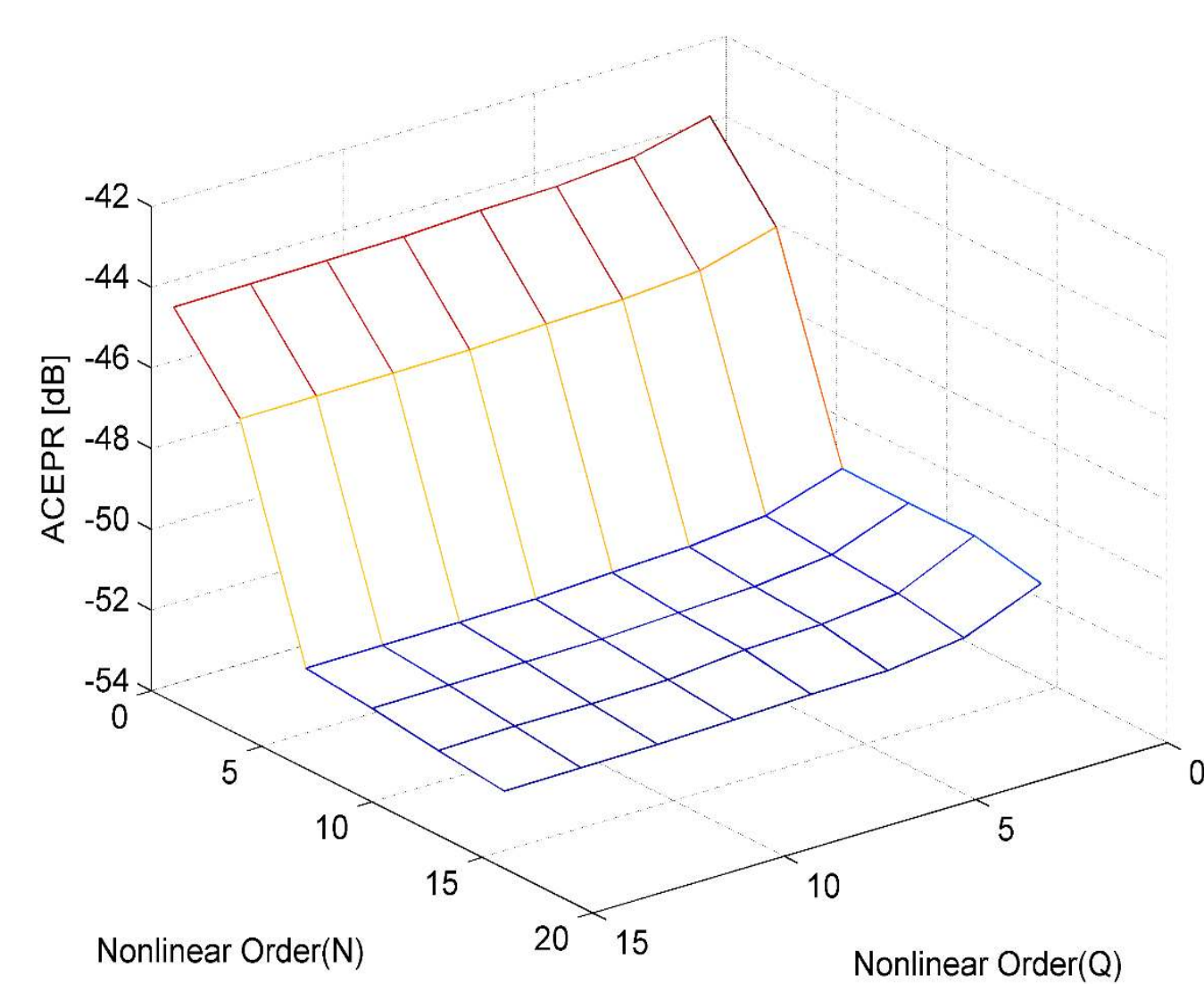

Fig. 4. NMSE and ACEPR versus nonlinear orders N and Q of the AM/PM Taylor model. The Extended Saleh model simulations are obtained for $N_A=2$, $N_B=1$, $M_{AM}=5$, $M=12$.

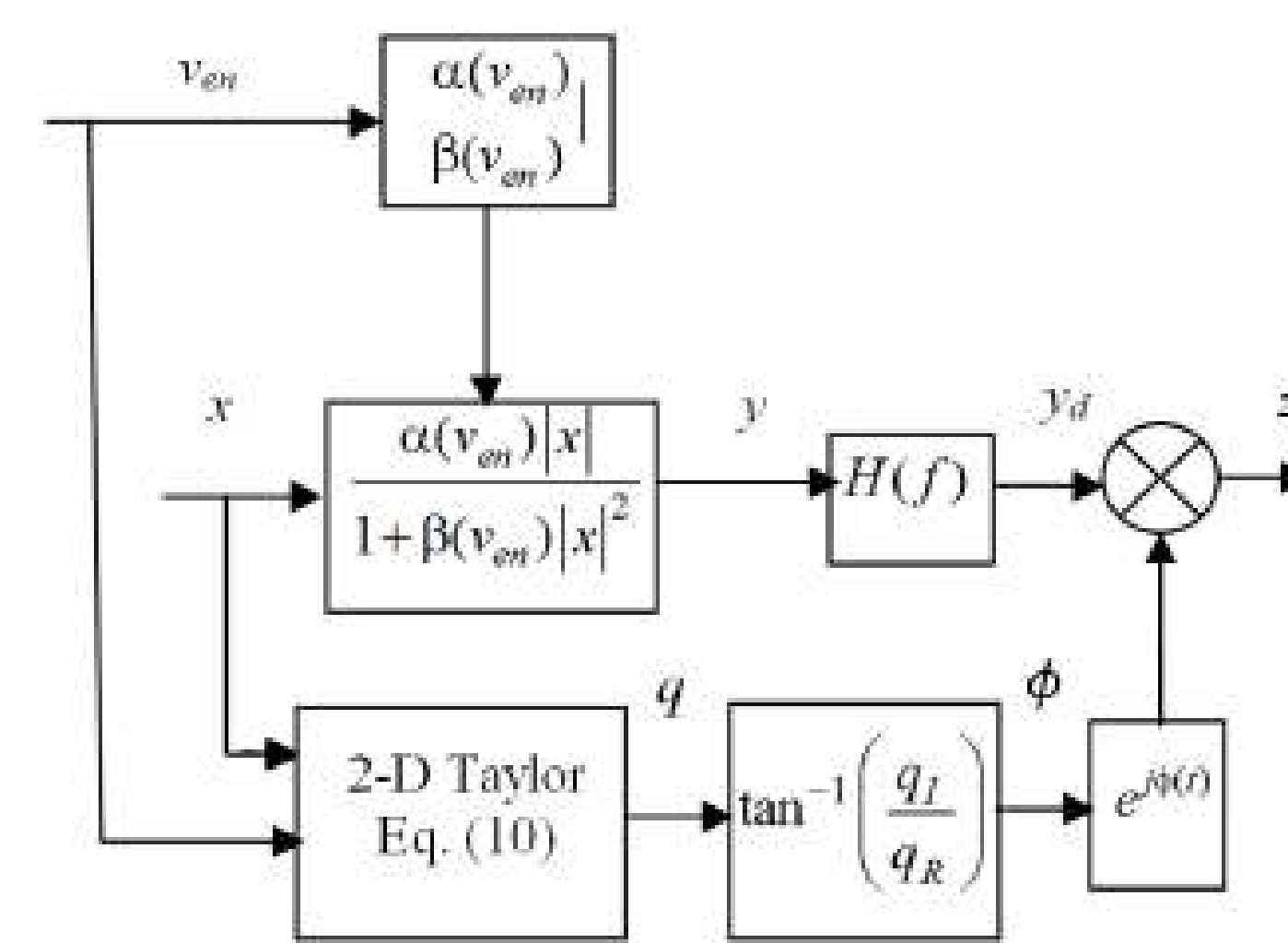

Fig. 2. Block diagram of extended Saleh model for ET PAs proposed in this work.

$$y = \frac{\alpha(v_{en})|x|}{1 + \beta(v_{en})|x|^2}$$

$$\alpha(v_{en}) = \sum_{i=1}^{N_A} \alpha_i v_{en}^i$$

$$\beta(v_{en}) = \sum_{i=1}^{N_B} \beta_i v_{en}^i$$

$$y_d[n] = \sum_{k=0}^{M_{AM}} h[k]y[n-k]$$

$$q(n) = \sum_{k=0}^Q \sum_{j=0}^N \sum_{m=0}^M P_{(k,j,m)} x^j(n-m) v_{en}^k(n-m)$$

Simulation environment

The proposed model is validated and evaluated in MATLAB by using simulation data produced in Advanced Design System (ADS). The ADS schematic is depicted in Fig. 3. ADS simulations are based on LTE downlink signal of 5MHz bandwidth.

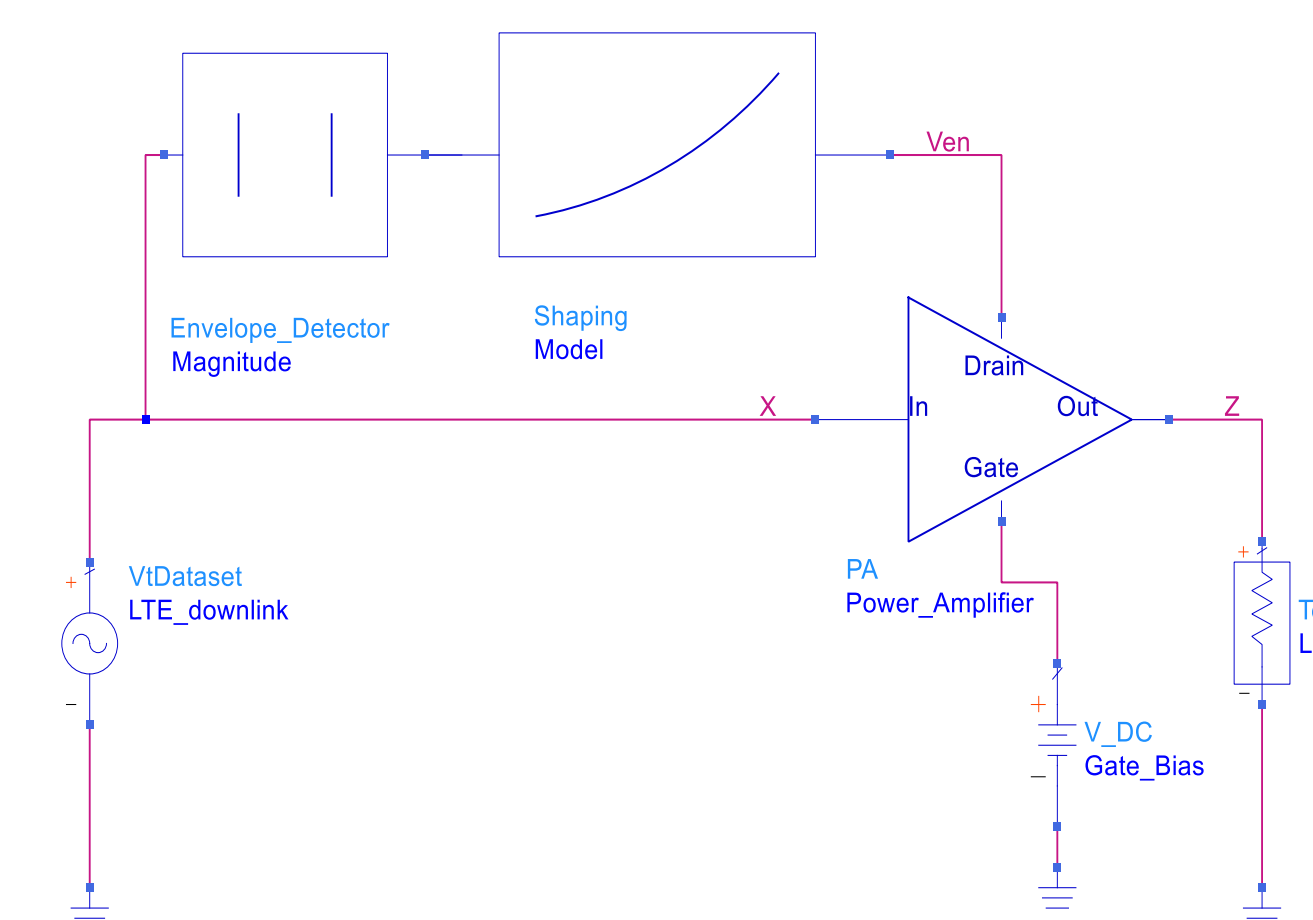

Fig. 3. Circuit schematic used for the simulation of the ET PA using Advanced Design System (ADS).

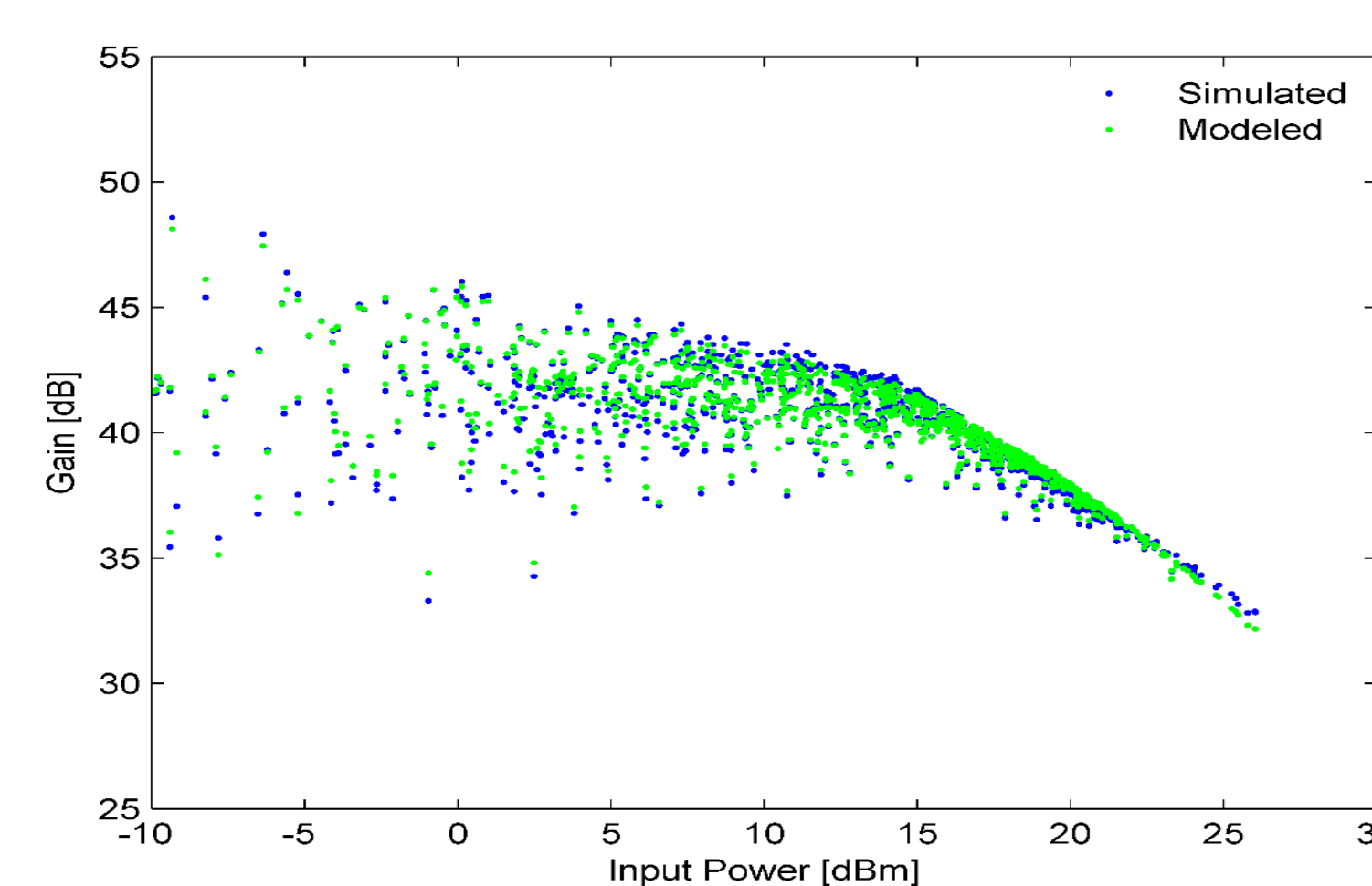
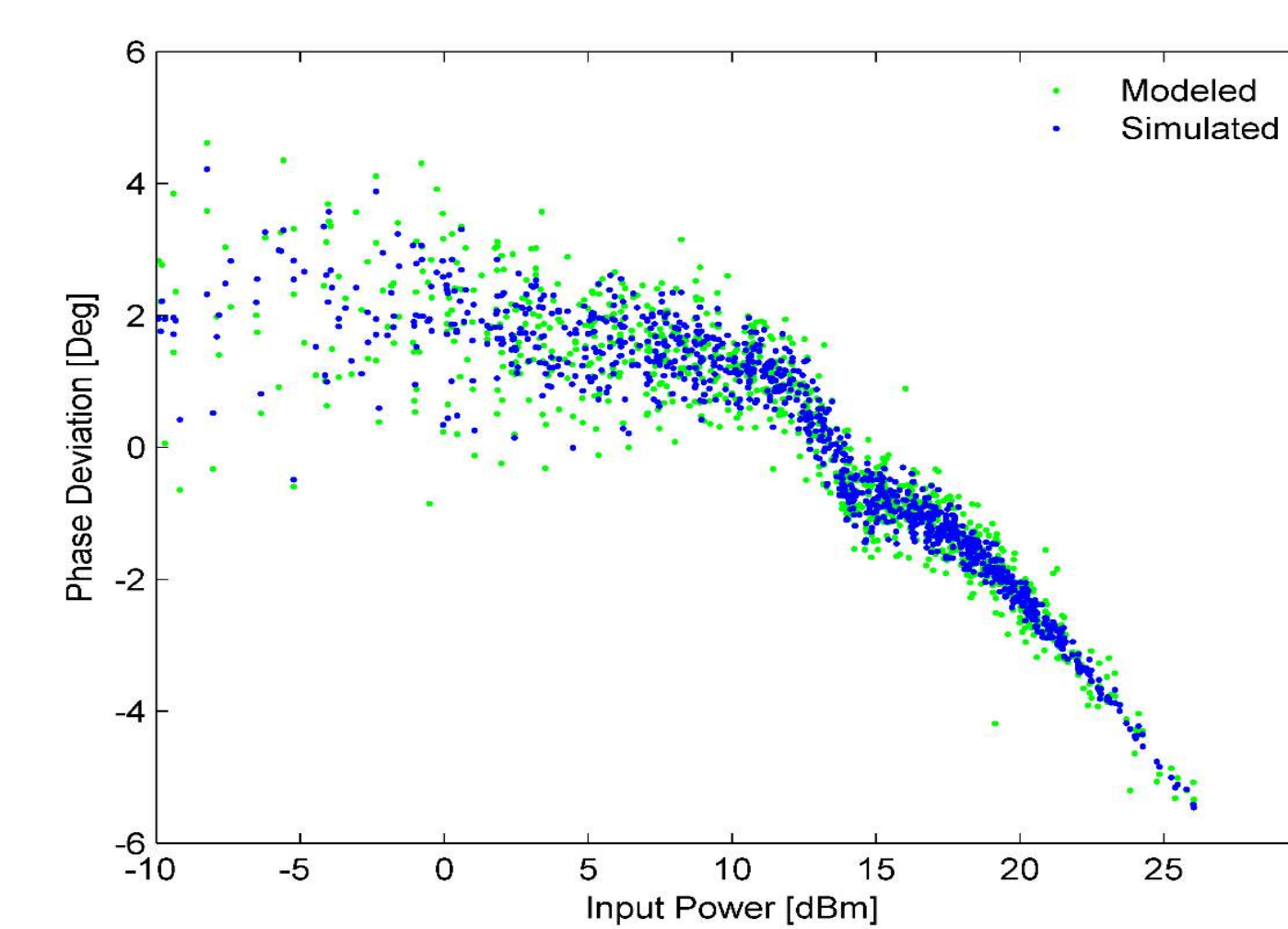

Fig. 5. Gain and phase deviation of the ET PA simulated in ADS and the proposed extended Saleh model. The Extended Saleh model simulations are obtained for $N_A=2$, $N_B=1$, $M_{AM}=5$, $N=9$, $Q=7$, $M=12$.

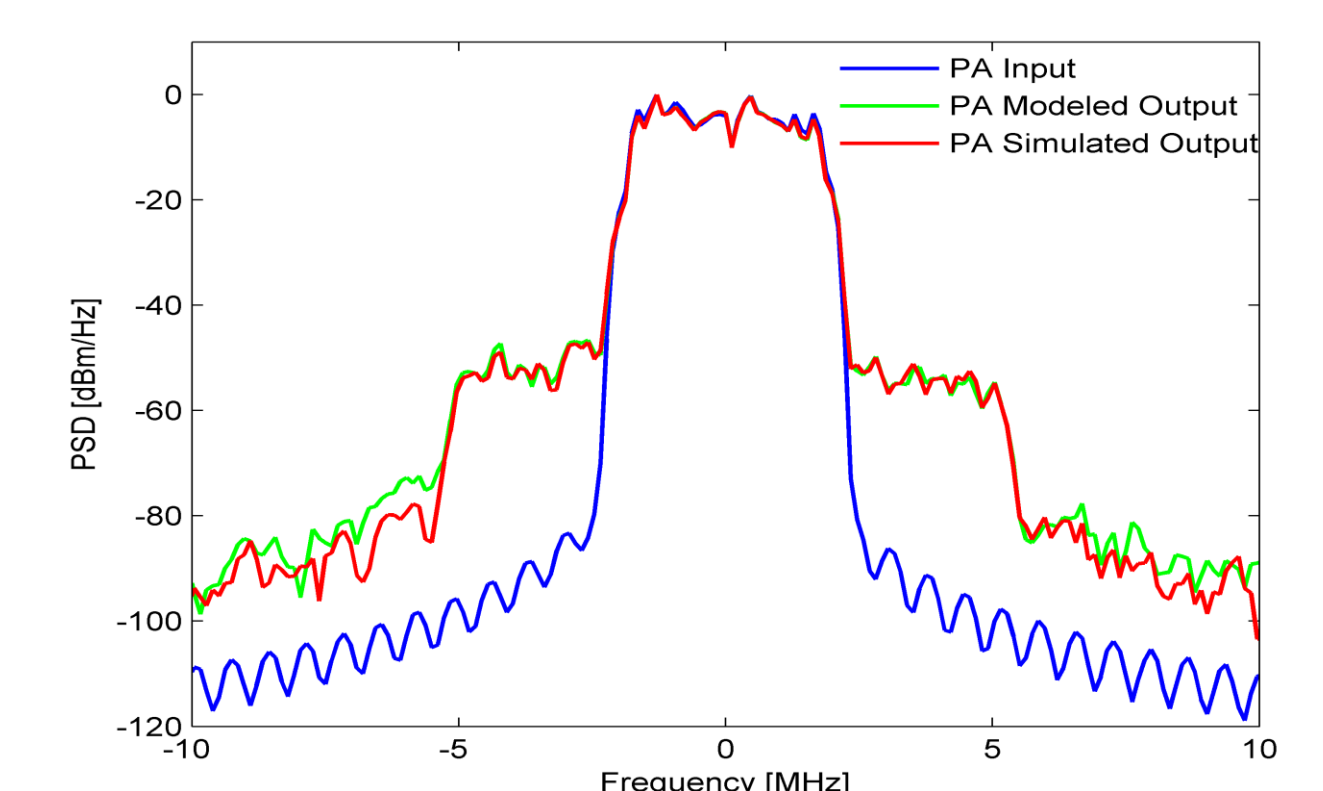

Fig. 6. Power spectral density (PSD) of the ET PA simulated in ADS and the proposed extended Saleh model. The Extended Saleh model simulations are obtained for $N_A=2$, $N_B=1$, $M_{AM}=5$, $N=9$, $Q=7$, $M=12$.

Conclusion

- A new behavioral model was proposed by extension of a static Saleh model for PA.
- The model parameters have been swept to evaluate the model performance.
- NMSE of -44.6 dB and ACEPR of -53.7 dB were observed as modeling best performance.