

NASA CONTRACTOR REPORT

NASA CR-2744

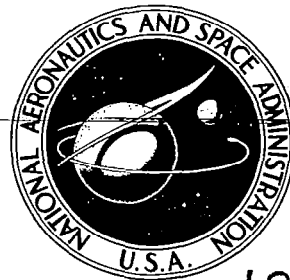

NASA CR-2744

0063395



TECH LIBRARY KAFB, NM

LOAN COPY: RETURN TO
AFWL TECHNICAL LIBRARY
KIRTLAND AFB, N. M.

FOR EARLY DOMESTIC DISSEMINATION

Because of its significant early commercial potential, this information, which has been developed under a U. S. Government program, is being disseminated within the United States in advance of general publication. This information may be duplicated and used by the recipient with the express limitation that it not be published. Release of this information to other domestic parties by the recipient shall be made subject to these limitations. Foreign release may be made only with prior NASA approval and appropriate export licenses. This legend shall be marked on any reproduction of this information in whole or in part.
Date for general release March 1979

FABRICATION AND EVALUATION OF ADVANCED TITANIUM STRUCTURAL PANELS FOR SUPERSONIC CRUISE AIRCRAFT

L. Payne

Prepared by

LOCKHEED-CALIFORNIA COMPANY

Burbank, Calif. 91520

for Langley Research Center

NATIONAL AERONAUTICS AND SPACE ADMINISTRATION • WASHINGTON, D. C. • MARCH 1977

FEDD DOCUMENT

Note that this document bears the label "FEDD," an acronym for "FOR EARLY DOMESTIC DISSEMINATION." The FEDD label is affixed to documents that may contain information having high commercial potential.

The FEDD concept was developed as a result of the desire to maintain U.S. leadership in world trade markets and encourage a favorable balance of trade. Since the availability of tax-supported U.S. technology to foreign business interests could represent an unearned benefit, research results that may have high commercial potential are being distributed to U.S. industry in advance of general release.

The recipient of this report must treat the information it contains according to the conditions of the FEDD label on the front cover.



0061395

1. Report No. NASA CR-2744	2. Government Accession No.	3. Recipient's Catalog No.	
4. Title and Subtitle FABRICATION AND EVALUATION OF ADVANCED TITANIUM STRUCTURAL PANELS FOR SUPERSONIC CRUISE AIRCRAFT		5. Report Date March 1977	6. Performing Organization Code
		8. Performing Organization Report No. LAC SP-4508	
7. Author(s) L. Payne		10. Work Unit No.	
9. Performing Organization Name and Address Lockheed-California Company Advanced Development Projects Division Burbank, California 91520		11. Contract or Grant No.	
		13. Type of Report and Period Covered Contractor Report	
12. Sponsoring Agency Name and Address National Aeronautics and Space Administration Washington, D.C. 20546		14. Sponsoring Agency Code	
		15. Supplementary Notes Two film supplements to this report are available on loan. These films describe fabrication and testing of panels and specimens produced using each of the fabrication methods investigated. Langley technical monitor: Edward L. Hoffman Topical report.	
16. Abstract Flightworthy primary structural panels were designed, fabricated, and tested to investigate two advanced fabrication methods for titanium alloys. Skin-stringer panels fabricated using the weldbraze process, and honeycomb-core sandwich panels fabricated using a Rohr Industries, Inc. diffusion bonding process, were designed to replace an existing integrally stiffened shear panel on the upper wing surface of the NASA YF-12 research aircraft. The investigation included ground testing and Mach 3 flight testing of full-scale panels, and laboratory testing of representative structural element specimens. Test results obtained on full-scale panels and structural element specimens indicate that both of the fabrication methods investigated are suitable for primary structural applications on future civil and military supersonic cruise aircraft.			
17. Key Words (Suggested by Author(s)) (STAR category underlined) Weldbrazing <u>Metallic Materials</u> Diffusion Bonding <u>Structural Panels</u> Fabrication Titanium Joining YF-12 Aircraft		18. Distribution Statement FEDD Distribution Subject Category 37	
19. Security Classif. (of this report) Unclassified	20. Security Classif. (of this page) Unclassified	21. No. of Pages 79	22. Price*

*Available: NASA'S Industrial Application Centers

FABRICATION AND EVALUATION OF
ADVANCED TITANIUM STRUCTURAL PANELS
FOR SUPERSONIC CRUISE AIRCRAFT

L. Payne

Lockheed-California Company
Advanced Development Projects Division

SUMMARY

Flightworthy primary structural panels were designed, fabricated and tested to investigate two advanced fabrication methods for titanium alloys. Skin-stringer panels fabricated using the weldbrazing process, and honeycomb-core sandwich panels fabricated using a Rohr Industries, Inc. diffusion bonding process, were designed to replace an existing integrally stiffened shear panel on the upper wing surface of the NASA YF-12 research aircraft. The investigation included ground testing and Mach 3 flight testing of full-scale panels, and laboratory testing of representative structural element specimens.

Test results obtained on full-scale panels and structural element specimens indicate that both of the fabrication methods investigated are suitable for primary structural applications on future civil and military supersonic cruise aircraft.

INTRODUCTION

The development of advanced fabrication methods for titanium alloys and high temperature composite materials is an important area of structures and materials research being conducted as part of the National Aeronautics and Space Administration Supersonic Cruise Aircraft Research (SCAR) Program.

The objective of this research is to provide a sound data base of technology to support the selection of new fabrication methods and materials for future civil and military supersonic cruise aircraft structures. Fabrication and service testing of complete structural components is an effective means of providing such data.

This report describes a program in which flightworthy primary structural panels were designed, fabricated, and tested to investigate two advanced fabrication methods for titanium alloys. Skin-stringer panels were fabricated using a weldbrazing process originated by the NASA Langley Research Center. A Rohr Industries, Inc. liquid interface diffusion bonding process was used to fabricate honeycomb-core sandwich panels. These panels were designed to replace an existing integrally stiffened shear panel on the upper wing surface of the NASA YF-12 research aircraft. The program included ground testing and Mach 3 flight testing of these full-scale panels, and laboratory testing of representative structural element specimens.

Fabrication methods are described, and test results for the panels and their associated specimens are presented. Data on relative structural efficiencies and costs are also presented.

The units for physical quantities used in this report are given in both the International System of Units (SI) and in U.S. Customary Units. Measurements and calculations were made in U.S. Customary Units.

Two film supplements to this report are also provided. These films describe the fabrication and testing of panels and specimens produced using each of the fabrication methods investigated.

DESIGN REQUIREMENTS

Structural panels in several different locations on the upper wing surface of the YF-12 aircraft were originally considered as candidates for replacement with panels fabricated using advanced methods. Each of these panels was critical for a different type of aircraft loading. Of these panels, a 40.6 x 71.1 cm (16 x 28 in.) shear panel was selected as affording the most challenging design requirements. The location of this panel on the right and left hand wing of the aircraft is indicated by the rectangular outlines in figure 1.

The existing aircraft panel is an integrally stiffened skin-riser type structure machined from titanium plate. The weight of this panel is 3.86 kg (8.50 lbm).

Panels fabricated for this program were designed to have equal capability, in all essential functional aspects, as the aircraft panel they were intended to replace. While design ultimate shear strength at room temperature and 589 K (600°F) was the principal requirement, the panels were also designed to sustain all other critical flight loading conditions, and to be compatible with the aircraft substructure.

The structural element specimens were designed to be representative of the full-scale panel constructions and fabrication methods investigated.

FABRICATION METHODS

Weldbrazed Panels and Specimens

Weldbrazing is a joining process, originated by the NASA Langley Research Center, which has demonstrated superior structural characteristics over more conventional joining practices for titanium alloys (ref. 1). The

process combines resistance spotwelding and brazing. Spotwelding is used to produce a controlled gap at the faying surface. During vacuum brazing, 3003 aluminum braze alloy flows into the faying surface gap by capillary action to produce a continuous, high strength joint.

To investigate this fabrication method, Lockheed-Advanced Development Projects designed and fabricated ten full-scale panels, twenty-five compression specimens, and one-hundred lap shear specimens. Eight of the full-scale panels, and all of the compression and lap shear specimens were used in the testing programs. Two of the full-scale panels were intended to serve as spares.

Panel and specimen configuration. - The general configuration of the full-scale weldbrazed panel assembly is shown in figure 2. It consists of an annealed Ti-6Al-4V titanium skin, chem-milled in the center to a thickness of 0.178 cm (0.070 in.). Thirteen "Z" type stiffeners, at 5.08 cm (2.00 in.) spacing, were spotwelded and subsequently vacuum brazed to the skin using 3003 aluminum alloy. The stiffeners were formed from 0.127 cm (0.050 in.) annealed Ti-6Al-4V titanium alloy sheet.

Twenty-five compression specimens, of the configuration shown in figure 3, were machined from a full-scale panel fabricated using stiffeners without scarfed ends.

The configuration of the one-hundred lap shear specimens is shown in figure 4. These specimens were representative of the full-scale panel construction in that 0.127 cm (0.050 in.) and 0.180 cm (0.071 in.) sheet thicknesses were used. They were fabricated using the same procedures used for the full-scale panels. The overlap of 0.952 cm (0.375 in.) and the width of thinner sheet were chosen to preclude parent metal failures. The doublers were added to reduce eccentric loading on the weldbrazed joint and to preclude bearing failures at the loading holes. To minimize handling, and maintain

cleanliness, spotwelding of these doublers and final sizing of the loading holes were accomplished after vacuum brazing of the specimens.

Three lap shear specimens of the same configuration shown in figure 4, and one skin-angle type specimen, as shown in figure 5, accompanied each full-scale panel throughout the fabrication process, as quality control specimens. The skin-angle specimen represented the "foot" of the "Z" type stiffener, and its attachment to the skin, using the same spotweld spacing and edge distance.

Fabrication procedures. - Prior to assembly, all detail parts for the panels and quality control specimens, including the 3003 aluminum braze alloy, were chemically cleaned. The cleaning procedures used are outlined in appendix A. Following cleaning, all parts were handled with plastic or clean, lint-free nylon gloves.

The stiffeners were indexed on the skin panel in a spotwelding fixture using aluminum bars, as shown in figure 6. Each stiffener was spotwelded to the skin in three places through access holes provided in the index bars and the base of the fixture, as shown in figure 7. The index bars were then removed from the fixture to complete spotwelding of the stiffeners to the skin. See figure 8. Spotwelding fixtures were also used to assemble the lap shear and skin-angle quality control specimens, as shown in figures 9 and 10.

All spotwelding was accomplished using a previously established welding schedule which produced a 0.008 - 0.010 cm (0.003 - 0.004 in.) gap at the faying surfaces between parts. The spotwelding parameters used to produce this gap are given in appendix B. Three standard, single-spotweld shear specimens were assembled and tested, just prior to and following welding of the panel and quality control specimens, to verify that machine settings were maintained. All assembled parts were checked using feeler gauges to insure that the proper gap was obtained.

Narrow strips of 0.041 cm (0.016 in.) 3003-H14 aluminum alloy sheet, which had been scarfed to a knife-edge along one side, were then wedged into the faying surface gaps at the foot of each stiffener, and on the quality control specimens, to hold them in place during brazing. A panel assembly, with the aluminum braze alloy strips installed, is shown in figure 11.

The panel assembly and quality control specimens were then individually wrapped in kraft paper, sealed in polyethylene bags with desiccant and humidity indicators, and boxed for transportation to a local vacuum brazing facility. Simulated full-scale panel assemblies had been used to qualify a particular vacuum furnace at this facility to perform the brazing operation.

Immediately prior to vacuum brazing, the furnace was loaded with cleaned titanium remnant material and pre-fired at 1367 K (2000°F), for one hour, to remove furnace contaminants. During this time, a vacuum of 1.33 mPa (10^{-5} torr) was maintained.

Following this operation, the panel assembly and quality control specimens were placed in the furnace on a molybdenum rack as shown in figure 12. The quality control specimens were positioned on top of the stiffeners on the panel to prevent possible contamination of the rack or furnace heating elements, should excessive flow of the aluminum braze alloy occur.

Separate, thermocoupled temperature monitoring assemblies were placed on the furnace rack at each corner of the panel assembly, and on top of the panel near its center. These assemblies were used to provide an accurate indication of part temperature, without attaching thermocouples directly to the panel. These assemblies were identical to the skin-angle quality control specimen which accompanied each panel, except that no braze alloy was used.

A programmed, automatic furnace temperature controller was used to maintain proper time-temperature relationships during the brazing cycle.

The complete vacuum brazing cycle used for each of the full-scale panels is described below, and is also shown in figure 13.

- (1) The vacuum at start of furnace heat-up was at least 1.33 mPa (10^{-5} torr).
- (2) The temperature was increased from ambient to 867 K (1100°F) in thirty minutes.
- (3) Part temperature was allowed to stabilize at approximately 867 K (1100°F \pm 20°F) for seven minutes.
- (4) The temperature was then increased to 972 K (1290°F) in five minutes.
- (5) Part temperature was stabilized, and brazing accomplished, at 972 K (1290°F \pm 5°F) for ten minutes.
- (6) Power to the furnace heating elements was then shut off and the part cooled to at least 617 K (650°F) under vacuum, at which time high-purity argon gas was introduced. The part was cooled to at least 367 K (200°F) before the furnace door was opened, exposing the parts to the atmosphere.

The temperatures indicated are those measured on the five separate thermocoupled assemblies provided for that purpose. Time, temperature, and vacuum were continuously monitored and recorded. The vacuum, at the brazing temperature of 972 K (1290°F), ranged from 13.3 mPa (10^{-4} torr) to 6.67 mPa (5×10^{-5} torr).

A full-scale weldbrazed panel assembly and its quality control specimens are shown in figure 14.

This same procedure was used to fabricate the full-scale panel required to provide the twenty-five compression specimens. The one-hundred lap shear specimens were vacuum brazed, using the same procedure, in five consecutive furnace loads of twenty specimens each.

Nondestructive evaluations. - Following vacuum brazing, all weldbrazed panels and specimens were examined visually for proper flow and filleting of the aluminum braze alloy. All spotwelds were inspected radiographically. A through-transmission, ultrasonic C-scan procedure was used to inspect for defective areas in the brazed joints. The three lap shear quality control specimens, which accompanied each panel and furnace load of specimens, were tested to failure and the fracture surfaces examined to evaluate the quality of the brazed joints. The skin-angle quality control specimens were sectioned in two directions, and the brazed joint examined metallographically.

Diffusion Bonded Honeycomb-Core Sandwich Panels and Specimens

The second type of titanium fabrication method investigated as part of this program was a Rohr Industries, Inc liquid interface diffusion bonding process (ref. 2). This process consists of selectively electroplating the components to be joined, with layers of several different materials. At temperature, in a vacuum, these materials combine with the titanium to form a eutectic liquid. As the percentage of titanium in the liquid increases, it solidifies and solid state diffusion occurs. The final composition of the diffusion bonded joint approaches that of the titanium base metal. Titanium structural components manufactured using this process are referred to as "RohrBond" products.

Under subcontract to Lockheed-Advanced Development Projects, Rohr Industries, Inc. - High Temperature Structures Division, designed and fabricated ten full-scale structural panels, sixty-four flatwise tension specimens, and seven sub-scale panels, using this process. Eight of the full-scale panels and all of the flatwise tension specimens were used in the testing programs. Again, two of the full-scale panels were intended as spares. The sub-scale panels were used by the NASA Langley Research Center for an independent study of this fabrication method.

Panel and specimen configuration. - The configuration of the full-scale diffusion bonded panel assembly is shown in figure 15. It consists of an annealed Ti-6Al-4V titanium frame, fabricated from four machined edge members, fusion welded at the corners; annealed Ti-3Al-2.5V titanium honeycomb-core; and annealed Ti-6Al-4V titanium face sheets. The liquid interface diffusion bonding process was used to join the face sheets to the core and to the edge member frame.

Sixty-four, 6.35 cm (2.50 in.) square, flatwise tension specimens were machined from one 66.0 cm (26 in.) square panel which was assembled without edge members. The core and face sheets used in this panel assembly were the same as those used to fabricate the full-scale structural panels.

The seven sub-scale panels were identical in construction to the full-scale panels, including edge members, except that they measured 20.3 x 30.5 cm (8 x 12 in.) rather than 40.6 x 71.1 cm (16 x 28 in.).

Fabrication procedures. - For the full-scale diffusion bonded panels, four titanium edge member angles were first machined to the appropriate cross-sectional dimensions, and mitered at 45 degrees on each end. These angles were then clamped in a fixture and the mitered butt joints fusion welded to form an edge member frame. The welds were machined flush and inspected radiographically. The frame assembly was subsequently stress relieved to remove residual stresses induced during the welding operation.

The titanium honeycomb-core, which had been machined to the proper height, was then positioned in the frame and each individual cell wall resistance spotwelded to the frame in five places.

This sub-assembly and the face sheets were then chemically cleaned, selectively masked, and electroplated with the materials required for the liquid interface diffusion bonding process. The core was filled with maskant and honed to expose only the ends of the cells for plating. The face sheets were

masked to expose only those surfaces which were to mate with the edge member frame.

Following laboratory certification of the plated surfaces, the maskant was removed from the various components, and the two face sheets positioned on the frame/core sub-assembly. Titanium foil and tack welds were used to hold the face sheets in place.

The panel assembly, and necessary tooling, were then laid-up on a flat carbon block in preparation for the bonding operation. Slip sheets, coated with stop-off material were first placed on the block. The panel was placed on the slip sheets with the outer face sheet down. A mild steel tooling frame, with a rectangular opening slightly larger than the panel, was positioned on the block around the panel. Additional slip sheets and a foil shield were placed over the exposed surfaces of the panel. The cavity inside the tooling frame was then filled with a specific quantity of tungsten pellets to provide the pressure required during bonding. Steel bars were used to provide additional pressure on the face sheet to frame joints. Thermocouples were attached to separate blocks placed on top of the tungsten pellets.

This complete package, as shown in figure 16, was then placed in the furnace and heated to 1208 K (1715°F) for ninety minutes, at a vacuum of 6.67 mPa (5×10^{-5} torr), to accomplish the diffusion bonding of the panel assembly. Time, temperature, and vacuum were continuously monitored and recorded throughout the bonding cycle. A full-scale diffusion bonded panel is shown in figure 17.

Design verification tests, conducted by Rohr early in the program, demonstrated adequate strength of the diffusion bonded joint between the inner face sheet and the narrow mating edge of the frame members. However, during fabrication of the panels, considerable difficulty was experienced in obtaining void free bonds at this joint. A special technique, using electron beam welding, was developed to repair such defects. All of the panels required this type

of repair to some extent, and it was ultimately decided that the entire periphery of this joint should be welded regardless of the extent of voids present.

The seven sub-scale panels were fabricated and diffusion bonded in the same manner as the full-scale panels, except that a slightly different tooling concept was used. A steel tray, filled with a quantity of tungsten pellets, was used to provide pressure on the face sheets where they were joined to the honeycomb-core. Stainless-steel tooling core and a separate tray were nested around the first tray, as shown in figure 18, and a different quantity of pellets used to provide higher pressure on the face sheet-to-frame joints.

The sixty-four flatwise tension specimens were machined from a 66.0 cm (26.0 in.) square panel assembled without edge members. For this panel, a titanium tooling frame, which fit tightly around the periphery of the panel, was used to prevent horizontal displacement of the face sheets during bonding. Again, a tray containing tungsten pellets was used to apply pressure. This panel and its tooling are shown in figure 19, just prior to lay up on the carbon block, in preparation for the diffusion bonding cycle.

Unfortunately, the quality of the face sheet-to-core bond was not consistent throughout this panel. Small voids, which at the time were deemed acceptable, resulted in low strength and unusually large test scatter when specimens from certain portions of this panel were tested. A smaller panel, of the same construction, was subsequently fabricated to supply replacement specimens which were more representative of the quality of the bond over the majority of the original panel.

Nondestructive evaluations. - During fabrication, the fusion welds at the corners of the edge member frames of the full-scale and sub-scale panels were subjected to dye penetrant and radiographic inspections for external and internal defects.

Following diffusion bonding, each panel assembly was inspected using two different ultrasonic methods. A through-transmission, C-scan technique was used to detect disbonds between the face sheets and the edge member frame. A pulse-echo, C-scan procedure was used to inspect the bond between the face sheets and the honeycomb-core. To further evaluate the quality of the face sheet-to-core bonds, a flatwise tension proof loading was applied to opposing test plugs, temporarily adhesively bonded to the inner and outer face sheets of the full-scale and sub-scale panels.

The electron beam welds used at the inner face sheet-to-edge member frame joints were also inspected radiographically.

TESTING PROGRAMS

Full-Scale Panels

Eight full-scale panels, fabricated by each of the two methods investigated, were used in a ground and flight testing program.

Prior to flight testing, four panels of each type were tested to failure in shear to verify the structural integrity of the panel design and fabrication method. Two of these panels were exposed to 589 K (600°F) for 100 hours, prior to testing, while the other two were not. One each of the exposed and unexposed panels was tested to failure at room temperature, and one each at 589 K (600°F).

Another panel, of each type, was then proof loaded to two-thirds of ultimate design shear load at room temperature, and installed on the YF-12 aircraft to accumulate Mach 3 flight experience. Periodically, these panels were removed and inspected for evidence of structural damage or degradation. Following flight service, each of these panels was subjected to the same non-destructive evaluations used when the panel was manufactured, to assess the

effects of the flight service experience. The panels were then proof loaded again, to verify the results of the non-destructive evaluations, and tested to failure at room temperature.

Three other full-scale panels of each type were proof loaded and subjected to long term exposures. Two panels were subjected to 1000 thermal cycles from 219 K to 589 K (-65°F to 600°F), as shown in figure 20, to simulate a three hour aircraft mission with two hours cruise at supersonic speeds. Sea level pressure was maintained during one of these cyclic exposures. During the other, the pressure was varied to simulate an altitude of approximately 21.3 km (70 000 ft.) while the temperature was at 589 K (600°F). Another panel was exposed to a constant temperature of 589 K (600°F) for 10 000 hours. Following exposure, each of these panels was subjected to nondestructive evaluation, proof loaded again, and tested to failure at room temperature.

The NASA Flight Research Center accomplished the constant temperature, and constant pressure cyclic exposures. The cyclic exposure in which the pressure was varied, was performed by the NASA Langley Research Center. Lockheed-Advanced Development Projects conducted all of the proof loadings and tests to failure.

Structural Element Specimens

A laboratory test program was also conducted on structural element specimens, representative of the two full-scale panel constructions and fabrication methods. Lap shear and compression specimens were used for the weldbrazed skin-stringer panels. Flatwise tension specimens were used for the diffusion bonded honeycomb-core sandwich panels.

All of these specimens were tested at room temperature by the NASA Flight Research Center. Specimens were tested following no exposure, and after exposure to 478 K, 589 K, 700 K and 811 K (400°F, 600°F, 800°F and 1000°F) for 100, 1000, 5000 and 10 000 hours. Two groups of specimens were

also subjected to 1000 thermal cycles from 219 K to 589 K (-65°F to 600°F). As with the full-scale panels, the pressure was maintained at sea level for one of these cyclic exposures, and was varied during the other.

The constant temperature, and constant pressure cyclic exposures of these specimens were also performed by the NASA Flight Research Center. The NASA Langley Research Center accomplished the cyclic exposure in which the pressure was varied.

TESTING PROCEDURES

Full-Scale Panels

Full-scale panels were proof loaded and tested to failure in shear using a ground test fixture designed and fabricated by Lockheed-Advanced Development Projects. The test fixture (figure 21) consists of a base, two 2.22 MN (500 000 lbf) capacity hydraulic jacks, and a cross-beam. A pin-jointed shear loading frame, installed between the base and the cross-beam, was designed to accept a sub-frame consisting of four sets of back-to-back titanium angles installed on the particular panel to be tested. Test loads were applied by regulating hydraulic pressure to the jacks using an Edison Load Maintainer.

Quartz lamps were used to heat the panels for testing at 589 K (600°F). Banks of lamps were positioned on both sides of the panel. The complete loading frame was enclosed with a removable oven extending between the two banks of lamps. Each bank of lamps was provided with three separate controllers to permit temperature adjustments in six separate zones. Air circulating fans and baffles were used to achieve uniform temperature distributions across the panel.

The panel and steel loading frame were heated to 589 K (600°F ± 20°F) and allowed to stabilize at that temperature for approximately thirty minutes

prior to testing. Thermocouples were used to monitor the temperature of the test panel and loading frame. The ground loading fixture, with the oven installed, is shown in figure 22. In figure 23, the oven is shown with one wall removed to show the heat lamp arrangement.

Structural Element Specimens

All of the structural element specimens were tested at room temperature, by the NASA Flight Research Center, using a 444.8 kN (100 000 lbf) capacity hydraulic testing machine. The arrangements used to test the weldbrazed lap shear and compression specimens are shown in figures 24 and 25, respectively. The platens used for the compression tests were ground to assure parallel loading surfaces.

To test the diffusion bonded flatwise tension specimens, steel loading blocks were adhesively bonded to each face sheet, using a fixture to maintain alignment. These blocks were threaded to accept self-aligning rod ends, as shown in figure 26, to assure pure tension loading of the specimens.

RESULTS AND DISCUSSION

Full-Scale Weldbrazed Panels

Results of the shear tests of full-scale weldbrazed panels are presented in table I and figure 27. The design ultimate shear strength for these panels was 680.3 kN/m (3885 lbf/in.) at room temperature and 424.7 kN/m (2425 lbf/in.) at 589 K (600°F).

The unexposed panel, tested at room temperature, failed at 132 percent of the design ultimate shear strength, while the panel which had been exposed to 589 K (600°F) for 100 hours, prior to testing, failed at 126 percent. At 589 K (600°F), the unexposed panel failed at 180 percent of the design ultimate strength for this temperature, and the panel that had been exposed to

589 K (600°F) for 100 hours failed at 166 percent. The slightly lower strength of the two panels which had been exposed to 589 K (600°F), prior to testing, is attributed to normal test scatter rather than to the effects of this exposure.

All of these panels failed in diagonal tension, after collapse of the stiffeners in forced crippling, or failure of the stiffener-to-skin attachment at the weldbrazed joint. A typical failure of a panel tested at room temperature is shown in figures 28 and 29. The failure shown in figures 30 and 31 is typical of the panels tested at 589 K (600°F).

The panels which had been subjected to cyclic thermal exposures at constant and varying pressures both failed at 134 percent of room temperature design strength. The panel exposed to 589K (600°F) for 10 000 hours, prior to testing, failed at 130 percent.

The panel, which had been installed on the YF-12 research aircraft, had accumulated a total of 106 hours flight service time prior to testing. Of this total, 31.7 hours was at speeds in excess of Mach 2.6, with 24.6 hours at Mach 3. This panel failed at 130 percent of room temperature design ultimate shear strength.

These test results indicate no loss in strength of the full-scale weld-brazed panels following either the long term exposures or actual flight service experience at supersonic speeds. They also confirmed the results of the non-destructive evaluations (conducted prior to testing) which had indicated no degradation of the weldbrazed joints.

Weldbrazed Structural Element Specimens

Test results for the weldbrazed lap shear and compression specimens are shown in table II and figures 32 and 33. As previously discussed, the lap shear specimens were vacuum brazed in five separate furnace loads of twenty specimens each. One specimen from each furnace load was subjected to each

of the various exposures indicated, prior to testing. The quantity of compression specimens fabricated for this program was not sufficient to allow for exposure to all of the conditions used for the lap shear specimens. Compression specimens were tested following only those specific exposures indicated in the table.

Typical failures of weldbrazed lap shear and compression specimens are shown in figures 34 and 35. The specimens shown in these figures as typical for specimens tested following cyclic thermal exposure are from the group of specimens where constant sea level pressure was maintained.

The data for the lap shear specimens show no degradation of the weld-brazed joint strength after 10 000 hours exposure to temperatures as high as 700 K (800°F), indicating metallurgical stability at this temperature. Joint strength was degraded, however, by exposure to 811 K (1000°F). The joint strength of specimens exposed to this temperature for 1000, 5000 and 10 000 hours is equivalent to the shear strength of the spotwelds alone. As can be seen in figure 34, the aluminum braze alloy on these specimens had completely converted to titanium aluminide and no longer contributed to the strength of the joint. This was also the case for the weldbrazed joint on the compression specimens exposed to 811 K (1000°F) for 1000 hours, except that it resulted in little or no degradation in the strength of the specimens. All of the compression specimens failed in local crippling. Apparently, the strength of the weldbrazed joint had little or no effect on the overall crippling strength of this type of specimen.

Full-Scale Diffusion Bonded Panels

The results of shear tests of the full-scale diffusion bonded honeycomb-core sandwich panels are shown in table III and figure 36. The design ultimate shear strength for these panels, at room temperature and 589 K (600°F), was the same as for the weldbrazed skin-stringer panels.

The unexposed panel, tested at room temperature, failed at 111 percent of the design shear strength of 680.3 kN/m (3885 lbf/in.). The panel exposed to 589 K (600°F) for 100 hours, prior to testing failed at 121 percent.

At 589 K (600°F), the unexposed panel was loaded to 127 percent of the design ultimate strength of 424.7 kN/m (2425 lbf/in.). While no visible failure had occurred in this panel, the plastic deformation was so great that the geometry of the shear fixture prevented further loading, and the test was discontinued. The shear loading fixture was subsequently modified to provide for considerably more panel deformation, and the panel which had been exposed to 589 K (600°F) for 100 hours was tested to failure at 589 K (600°F). This panel failed at 134 percent of the design ultimate strength for this temperature.

For the panels tested at room temperature, initial failures occurred at the welded corners of the edge member frame opposite the applied diagonal tension load. These failures propagated to the inner and outer face sheets which failed in primary shear or diagonal tension. A failure, typical of the panels tested at room temperature is shown in figures 37 and 38. Failure of the panel tested at 589 K (600°F) is shown in figures 39 and 40. The failure of this panel appears to have been initiated by transverse shearing of the honeycomb-core, permitting shear buckling of the inner and outer face sheets. This buckling was followed by failure of the face sheets, immediately adjacent to the edge member frame.

The diffusion bonded panels subjected to cyclic thermal exposures at constant and varying pressures failed at 121 and 124 percent of the room temperature design strength, respectively. The panel exposed to 589 K (600°F) for 10 000 hours, prior to testing, failed at 119 percent.

The panel installed on the YF-12 aircraft had accumulated 40 hours of flight service time, prior to testing. Of this total, 14.3 hours was at speeds in excess of Mach 2.6, with 7.8 hours at Mach 3. This panel failed at 126 percent of room temperature design ultimate shear strength.

The results indicate no degradation in the shear strength of full-scale diffusion bonded panels following either long term thermal exposures or flight service experience, and again confirmed the results of nondestructive evaluations conducted prior to testing.

Diffusion Bonded Structural Element Specimens

Test results for the diffusion bonded flatwise tension specimens are presented in table IV and figure 41. Typical failures are shown in figure 42.

As discussed elsewhere in this report, the original sixty-four specimens supplied by Rohr were machined from a single 66.0 cm (26.0 in.) square panel. Three specimens were to be tested following each of the various exposures. Initial tests of some of these specimens (identified with the prefix -004) resulted in lower strengths and more test scatter than had been anticipated. While the unexposed specimens exhibited high strength and very little test scatter, the results for specimens tested following 100 hours exposure at 478 K and 589 K (400°F and 600°F) indicated an unexpected loss in strength and a considerable amount of scatter.

A review of the nondestructive evaluation records for the panel fabricated to provide these specimens revealed that all of the unexposed specimens had been prepared from an area that was essentially free of bonding voids. The lower strength specimens were machined from a portion of the panel containing a number of small, normally acceptable disbonds. The lower strength of these specimens was attributed to the presence of the bonding voids, rather than to the effects of exposure.

To provide a larger test sample, additional specimens from this original panel were tested after no exposure and after 100 hours at 478 K (400°F). Rohr also provided supplementary test specimens prepared from a second, smaller panel which contained very few bonding voids. Some of these specimens (identified with the prefix -137) were tested after no exposure and after 100 hours at 589 K (600°F).

These additional tests provided more representative data for unexposed specimens and demonstrated that specimen strength was related to bond quality, rather than the effects of these short term exposures. For this reason, the data for one specimen (-004-15), which contained a large bonding void along one edge, was omitted from the data shown in figure 41 for specimens exposed to 478 K (400°F) for 100 hours. The fact that the strength of specimens exposed to 589 K (600°F) for 1000 hours is lower than specimens exposed to the same temperature for 5000 or 10 000 hours, and that the strength of specimens exposed 478 K (400°F) for 5000 hours is lower than for 10 000 hours, is also attributed to this variation in quality of the diffusion bonding on the original specimens.

In general, the data for diffusion bonded flatwise tension specimens indicate no degradation in strength of the diffusion bonded joint between the core and face sheets after 10 000 hours exposure to temperatures as high as 700 K (800°F). Specimen strength was degraded by exposure to 811 K (1000°F). Rohr has attributed this loss in strength to progressive oxidation of the thin Ti-3Al-2.5V titanium honeycomb-core, which resulted in embrittlement of the material and tension failures of the core, as shown in figure 42.

Relative Structural Efficiencies and Costs

The weight of the full-scale weldbrazed skin-stringer panels fabricated for this program was 3.84 kg (8.45 lbm); approximately equal to the 3.86 kg (8.50 lbm) integrally stiffened panel they were designed to replace. The diffusion bonded honeycomb-core sandwich panels weighed 3.28 kg (7.22 lbm), or 15 percent less than the integrally stiffened panel. Relative structural efficiencies (expressed as the ratio of design ultimate shear strength to panel weight) for these three types of panels are compared in figure 43. On the basis of this comparison, the weldbrazed panel is as efficient as the integrally stiffened panel, while the diffusion bonded panel is approximately 18 percent more efficient.

Cost estimates for the machined integrally stiffened panels, and weld-brazed and diffusion bonded panels are compared in terms of unit selling price (in 1975 dollars) in figure 44. Data for the machined panels are based on a learning curve of 90 percent, while data for the weldbrazed and diffusion bonded panels are based on learning curves of 88 percent. For one-hundred panels, the data indicate that diffusion bonded panels would cost approximately 3.5 percent more than the machined panel, while the weldbrazed panel would cost approximately 15 percent less.

CONCLUDING REMARKS

Two advanced fabrication methods for titanium alloys: (1) the weldbraze process and; (2) a Rohr Industries, Inc. liquid interface diffusion bonding process, have been demonstrated to be suitable for primary structural applications on future civil and military supersonic cruise aircraft.

Full-scale structural panels and representative structural element specimens were designed, fabricated, and tested to investigate each of two fabrication methods. Skin-stringer panels were fabricated using the weldbraze process. The Rohr process was used to fabricate honeycomb-core sandwich panels. These panels were designed to replace an existing shear panel on the upper wing surface of the NASA YF-12 research aircraft. The program included ground testing and Mach 3 flight testing of the full-scale panels, and laboratory testing of the structural element specimens.

Test results obtained on the full-scale panels indicate no loss in strength following exposure to 589 K (600°F) for up to 10 000 hours or after actual flight service experience at supersonic speeds. Test results for the structural element specimens show no degradation in the strength of either the weldbrazed or diffusion bonded joints after 10 000 hours exposure to temperatures as high as 700 K (800°F).

APPENDIX A

CLEANING PROCEDURES FOR WELDBRAZED PANELS AND SPECIMENS

Prior to assembly, all detail parts for the full-scale titanium weldbrazed panels and associated specimens, including the 3003 aluminum braze alloy, were chemically cleaned using the procedures outlined below:

Titanium Alloy Parts

(1) Remove mill markings, ink, and similar soils by wiping with clean cloths dampened with mild acidic cleaner.

(2) Immerse in alkaline cleaning solution (sodium hydroxide base):

Solution	- 60 kg/m ³ (8 oz./gal.) of water
Temperature	- 333 K to 355 K (140°F to 180°F)
Immersion time	- 15 minutes

(3) Spray rinse thoroughly with hot tap water:

Temperature	- 333 K to 344 K (140°F to 160°F)
Time	- 2 minutes minimum

(4) Repeat steps (2) and (3), as required, to obtain parts that are free of grease, oil, fingerprints, and similar soils. Scrubbing with a nonmetallic bristle brush dipped in the alkaline solution may be used to remove stubborn soils.

(5) Immerse in nitric-hydrofluoric acid solution:

Solution	- 30 percent nitric acid; 3 percent hydrofluoric acid, by weight
----------	--

Immersion time - sufficient to remove 0.0015 to 0.0020 cm (0.0006 to 0.0008 in.) of metal, measured on total thickness

- (6) Spray rinse immediately with cold tap water.
- (7) Spray rinse immediately with demineralized water.
- (8) Remove excess water using dry, filtered, oil-free compressed air.
- (9) Dry in circulating hot air oven at 394 K (250°F) maximum.

Aluminum Braze Alloy

- (1) Immerse in alkaline cleaning solution for aluminum alloys:

Solution - 45 kg/m³ (6 oz./gal.) of water
Temperature - 344 K to 355 K (160°F to 180°F)
Immersion time - 5 minutes

- (2) Spray or dip rinse thoroughly in hot tap water:

Temperature - 333 K to 344 K (140°F to 160°F)
Time - 2 minutes minimum

- (3) Immerse in nitric-hydrofluoric acid solution:

Solution - 30 percent nitric acid; 3 percent hydrofluoric acid, by weight
Immersion time - 5 minutes

- (4) Spray rinse immediately with cold tap water.
- (5) Spray rinse immediately with demineralized water.
- (6) Remove excess water using dry, filtered, oil-free compressed air.
- (7) Dry in circulating hot air oven at 344 K (160°F) maximum.

APPENDIX B

SPOTWELDING PARAMETERS FOR WELDBRAZED PANELS AND SPECIMENS

Spotwelding of the full-scale titanium weldbrazed panels, lap shear specimens, and quality control specimens was accomplished using a 100 kVA three-phase frequency converter resistance welding machine. A welding schedule, using the parameters listed below, was used to produce a 0.008 - 0.010 cm (0.003 - 0.004 in.) gap at the faying surfaces between parts.

Weld current phase shift	- 70 percent
Weld current time	- 3 cycles
Electrode force	- 4.893 kN (1100 lbf)
Electrode material	- Class 3
Electrode radius:	
Upper electrode	- 7.6 cm (3 in.), spherical
Lower electrode	- 25.4 cm (10 in.), spherical

All assemblies were positioned in the welder with the 0.127 cm (0.050 in.) thick sheet next to the upper electrode.

REFERENCES

1. Bales, Thomas T.; Royster, Dick M.; and Arnold, Winfrey E., Jr.:
Development of the Weld-Braze Joining Process. NASA TN D-7281, 1973.
2. Schwartz, M. M.: Rohrbond. 5th National SAMPE Technical Conference,
Kiamesha Lake, New York, October 1973.

TABLE I. - SHEAR STRENGTH OF WELDBRAZED PANELS

Panel	Exposure	Temperature	Shear strength	
			kN/m	lbf/in.
-05	None	Room	900.1	5140
-03	100 hrs. at 589 K (600°F)	Room	854.6	4880
-06	None	589 K (600°F)	763.5	4360
-04	100 hrs. at 589 K (600°F)	589 K (600°F)	705.7	4030
-10	1000 Cycles (a) 219 K to 589 K (-65°F to 600°F)	Room	910.6	5200
-09	1000 Cycles (b) 219 K to 589 K (-65°F to 600°F)	Room	910.6	5200
-07	10 000 hrs. at 589 K (600°F)	Room	882.6	5040
-01	Flight service	Room	882.6	5040

^a Constant sea level pressure

^b Varying pressure

TABLE II. - STRENGTH OF WELDBRAZED SPECIMENS

Failure load					
Lap shear specimens			Compression specimens		
Specimen	kN	lbf	Specimen	kN	lbf
No exposure					
-1	47.500	10 679	-001	93.097	20 930
-21	45.049	10 128	-002	93.719	21 070
-41	39.125	8 796	-003	92.563	20 810
-61	49.164	11 053			
-81	45.899	10 319			
100 hrs. at 478 K (400°F)					
-2	48.314	10 862			
-22	46.393	10 430			
-42	46.522	10 459			
-62	46.384	10 428			
-82	45.378	10 202			
100 hrs. at 589 K (600°F)					
-6	47.175	10 606			
-26	45.419	10 211			
-46	43.991	9 890			
-66	44.338	9 968			
-86	44.427	9 988			
100 hrs. at 700 K (800°F)					
-10	49.013	11 019			
-30	46.544	10 464			
-50	48.412	10 884			
-70	48.577	10 921			
-90	47.477	10 667			
100 hrs. at 811 K (1000°F)					
-14	48.101	10 814			
-34	49.426	11 112			
-54	43.737	9 833			
-74	45.076	10 134			
-94	48.981	11 012			

TABLE II. - Continued

Failure load					
Lap shear specimens			Compression specimens		
Specimen	kN	lbf	Specimen	kN	lbf
1000 hrs. at 478 K (400°F)					
-3	44.547	10 015			
-23	45.592	10 250			
-43	41.082	9 236			
-63	46.086	10 361			
-83	45.307	10 186			
1000 hrs. at 589 K (600°F)					
-7	45.592	10 250	-008	95.721	21 520
-27	46.273	10 403	-009	94.120	21 160
-47	44.178	9 932			
-67	45.730	10 281			
-87	47.416	10 660			
1000 hrs. at 700 K (800°F)					
-11	49.208	11 063	-012	97.812	21 990
-31	48.492	10 902	-013	93.230	20 960
-51	43.822	9 852			
-71	48.986	11 013			
-91	48.501	10 904			
1000 hrs. at 811 K (1000°F)					
-15	24.202	5 441	-016	88.782	19 960
-35	24.402	5 486	-017	93.230	20 960
-55	24.037	5 404	-018	91.762	20 630
-75	24.446	5 496			
-95	22.409	5 038			
1000 cycles 219 K to 589 K (-65°F to 600°F) (a)					
-18	44.529	10 011	-019	95.943	21 570
-38	46.348	10 420	-020	93.364	20 990
-58	45.765	10 289			
-78	46.904	10 545			
-98	44.769	10 065			

^a Constant sea level pressure

TABLE II. - Continued

Failure load					
Lap shear specimens			Compression specimens		
Specimen	kN	lbf	Specimen	kN	lbf
1000 cycles 219 K to 589 K (-65°F to 600°F) (b)					
-19	43.590	9 800	-021	98.523	22 150
-20	45.872	10 313	-022	96.522	21 700
-39	44.240	9 946	-023	95.943	21 570
-40	45.023	10 122	-024	99.012	22 260
-59	44.694	10 048	-025	99.234	22 330
-60	42.572	9 571			
-79	43.439	9 766			
-80	43.235	9 720			
-99	40.063	9 007			
-100	42.803	9 623			
5000 hrs. at 478 K (400°F)					
-4	46.464	10 446	-004	98.746	22 200
-24	45.808	10 312	-005	96.833	21 770
-44	42.185	9 484			
-64	46.059	10 355			
-84	43.039	9 676			
5000 hrs. at 589 K (600°F)					
-8	46.250	10 398			
-28	43.742	9 834			
-48	41.251	9 274			
-68	45.801	10 297			
-88	46.909	10 546			
5000 hrs. at 700 K (800°F)					
-12	49.924	11 224	-014	93.719	21 070
-32	48.394	10 880	-015	96.922	21 790
-52	45.250	10 173			
-72	49.342	11 093			
-92	39.881	8 966			

^bVarying pressure

TABLE II. - Concluded

Failure load					
Lap shear specimens			Compression specimens		
Specimen	kN	lbf	Specimen	kN	lbf
5 000 hrs. at 811 K (1000°F)					
-16	26.230	5 897			
-36	26.248	5 901			
-56	23.721	5 333			
-76	26.270	5 906			
-96	25.794	5 799			
10 000 hrs. at 478 K (400°F)					
-5	46.375	10 426	-006	95.276	21 420
-25	45.948	10 330	-007	95.276	21 420
-45	44.814	10 075			
-65	43.804	9 848			
-85	43.808	9 849			
10 000 hrs. at 589 K (600°F)					
-9	45.570	10 245	-010	97.900	22 010
-29	46.682	10 495	-011	96.299	21 650
-49	44.071	9 908			
-69	46.264	10 401			
-89	46.139	10 373			
10 000 hrs. at 700 K (800°F)					
-13	50.694	11 397			
-33	48.528	10 910			
-53	51.103	11 489			
-73	48.158	10 827			
-93	49.551	11 140			
10 000 hrs. at 811 K (1000°F)					
-17	27.164	6 107			
-37	27.248	6 126			
-57	27.800	6 250			
-77	27.778	6 245			
-97	26.750	6 014			

TABLE III. - SHEAR STRENGTH OF DIFFUSION BONDED PANELS

Panel	Exposure	Temperature	Shear strength	
			kN/m	lbf/in.
-009	None	Room	758.3	4330
-008	100 hrs. at 589 K (600°F)	Room	826.6	4720
-002	None	589 K (600°F)	541.1	3090
-001	100 hrs. at 589 K (600°F)	589 K (600°F)	569.1	3250
-010	1000 Cycles (a) 219 K to 589 K (-65°F to 600°F)	Room	826.6	4720
-007A	1000 Cycles (b) 219 K to 589 K (-65°F to 600°F)	Room	842.3	4810
-005	10,000 hrs. at 589 K (600°F)	Room	809.0	4620
-006	Flight service	Room	854.6	4880

^a Constant sea level pressure

^b Varying pressure

TABLE IV. - STRENGTH OF DIFFUSION BONDED
FLATWISE TENSION SPECIMENS

Specimen	Failure load	
	kN	lbf
No exposure		
-004-10	63.873	14 360
-004-11	64.496	14 500
-004-12	62.539	14 060
-004-77	60.048	13 500
-004-79	57.646	12 960
-004-80	55.956	12 580
-004-88	49.729	11 180
-137-24	56.223	12 640
-137-25	55.644	12 510
-137-26	56.934	12 800
100 hrs. at 478 K (400°F)		
-004-14	56.979	12 810
-004-15	39.561	8 894
-004-17	60.004	13 490
-004-86	55.778	12 540
-004-87	50.676	11 393
100 hrs. at 589 K (600°F)		
-004-30	56.979	12 810
-004-31	48.385	10 878
-004-32	52.442	11 790
-137-21	60.626	13 630
-137-22	56.934	12 800
-137-23	56.490	12 700
100 hrs. at 700 K (800°F)		
-004-43	62.450	14 040
-004-44	55.200	12 410
-004-46	59.336	13 340
100 hrs. at 811 K (1000°F)		
-004-58	55.111	12 390
-004-59	50.307	11 310
-004-60	46.063	10 356

TABLE IV. - Continued

Specimen	Failure load	
	kN	lbf
1000 hrs. at 478 K (400°F)		
-004-18	63.918	14 370
-004-19	64.185	14 430
-004-20	62.494	14 050
1000 hrs. at 589 K (600°F)		
-004-33	49.653	11 163
-004-34	46.357	10 422
-004-35	56.089	12 610
1000 hrs. at 700 K (800°F)		
-004-47	61.249	13 770
-004-48	63.117	14 190
-004-50	60.315	13 560
1000 hrs. at 811 K (1000°F)		
-004-61	38.996	8 767
-004-62	35.170	7 907
-004-64	40.392	9 081
1000 cycles 219 K to 589 K (-65°F to 600°F) (a)		
-004-74	58.580	13 170
-004-75	57.557	12 940
-004-76	60.671	13 640
1000 cycles 219 K to 589 K (-65°F to 600°F) (b)		
-004-83	53.300	11 983
-004-84	44.689	10 047
-004-85	50.084	11 260
-137-28	56.756	12 760
-137-30	61.204	13 760
-137-31	61.071	13 730

^aConstant sea level pressure

^bVarying pressure

TABLE IV. - Concluded

Specimen	Failure Load	
	kN	lbf
5 000 hrs. at 478 K (400°F)		
-004-22	45.632	10 259
-004-23	43.768	9 840
-004-24	45.223	10 167
5 000 hrs. at 589 K (600°F)		
-004-36	66.409	14 930
-004-37	61.916	13 920
-004-38	61.427	13 810
5 000 hrs. at 700 K (800°F)		
-004-51	57.023	12 820
-004-52	64.763	14 560
-004-54	57.913	13 020
5 000 hrs. at 811 K (1000°F)		
-004-66	12.192	2 741
-004-68	10.123	2 276
-004-69	10.724	2 411
10 000 hrs. at 478 K (400°F)		
-004-25	50.663	11 390
-004-27	66.231	14 890
-004-29	56.267	12 650
10 000 hrs. at 589 K (600°F)		
-004-39	62.494	14 050
-004-40	58.046	13 050
-004-41	58.580	13 170
10 000 hrs. at 700 K (800°F)		
-004-55	55.867	12 560
-004-56	57.913	13 020
-004-57	55.111	12 390
10 000 hrs. at 811 K (1000°F)		
-004-70	7.633	1 716
-004-72	8.055	1 811
-004-73	6.694	1 505

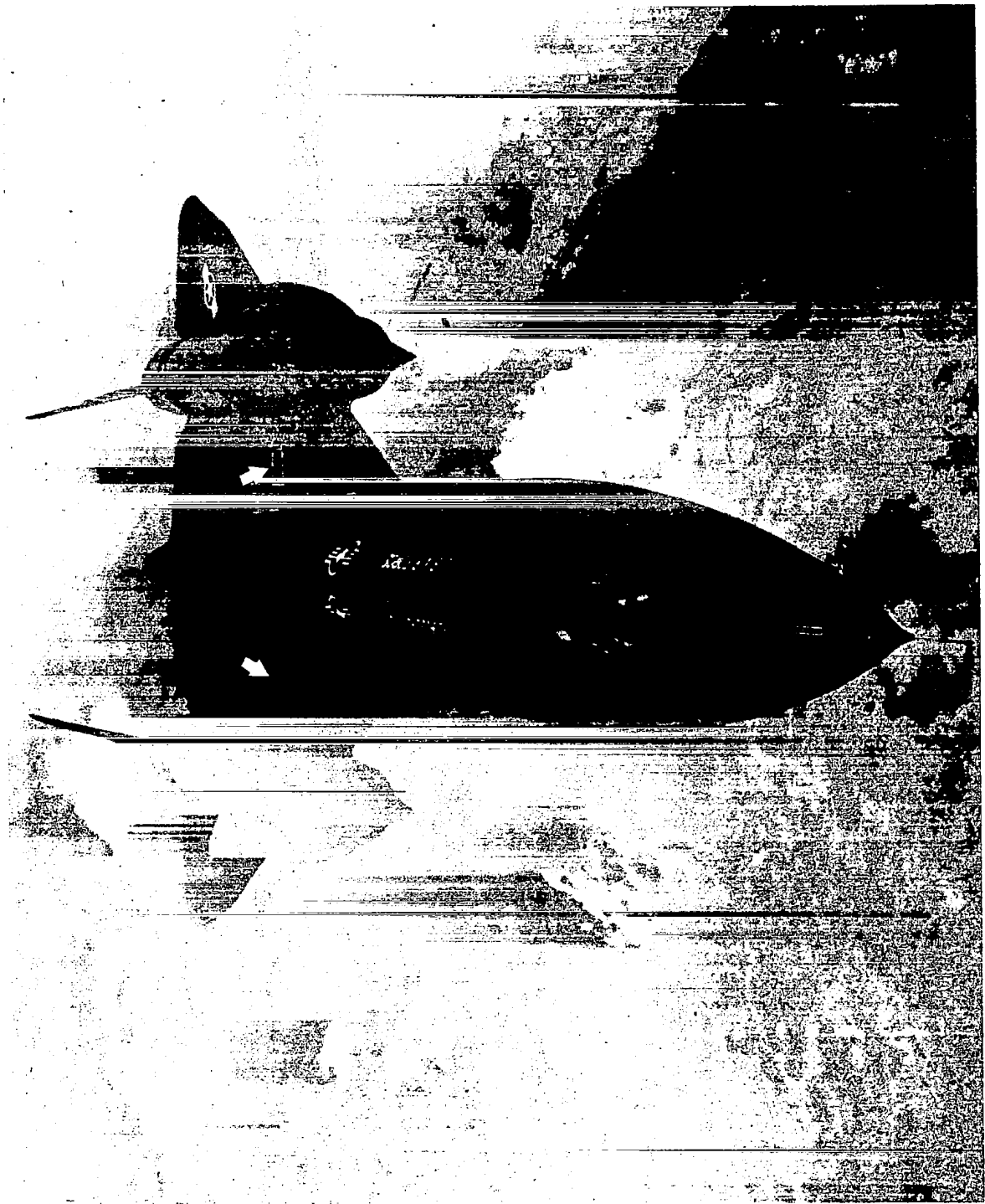

74-5242-1

Figure 1. - Test panel locations on YF-12 aircraft.

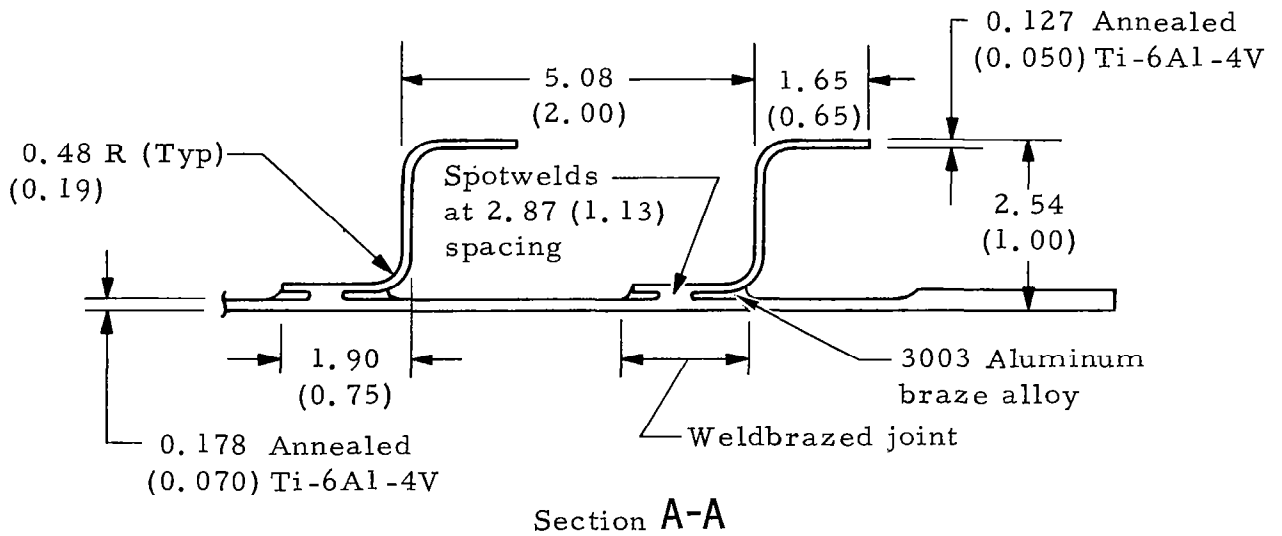
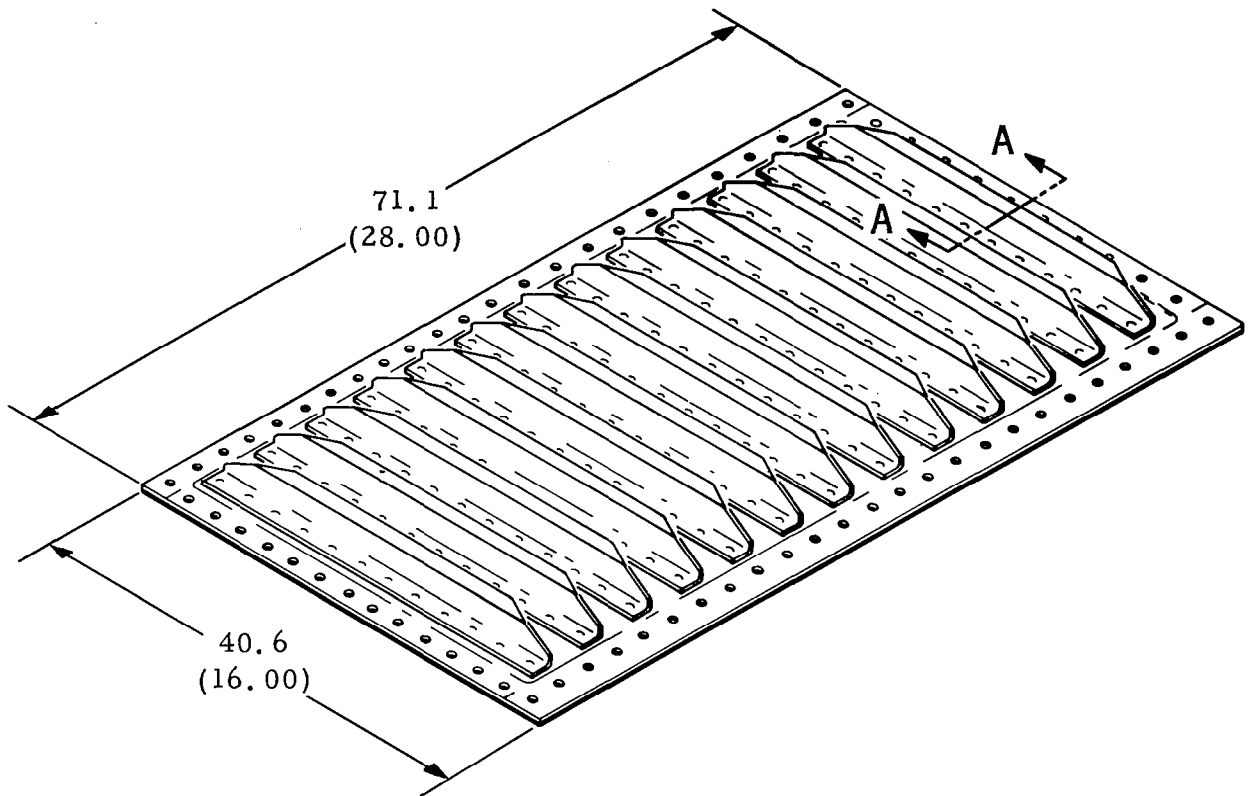

Figure 2. - Configuration of full-scale weldbrazed panel.
 Dimensions are given in centimeters (inches).

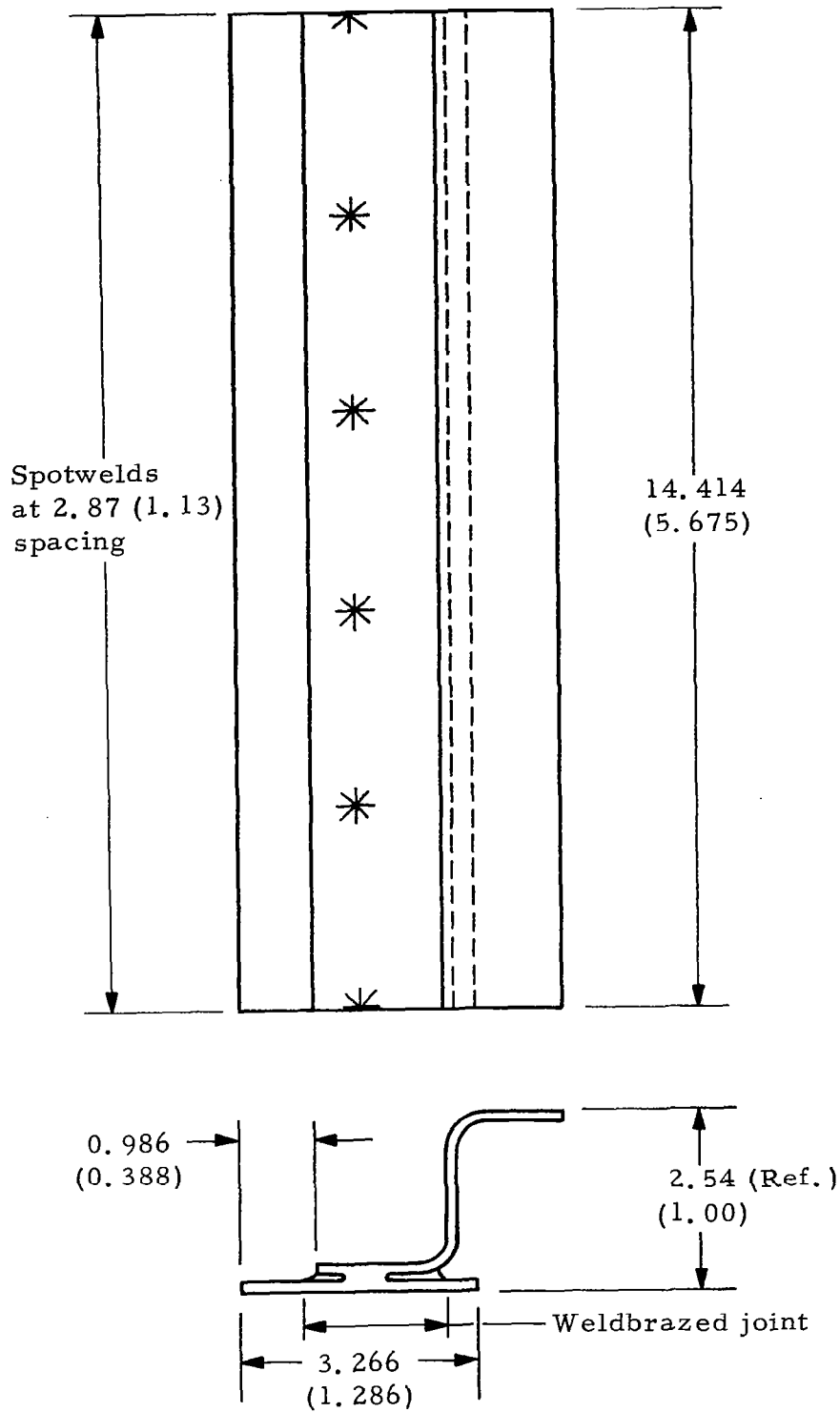

Figure 3. - Weldbraze compression specimen. Dimensions are given in centimeters (inches).

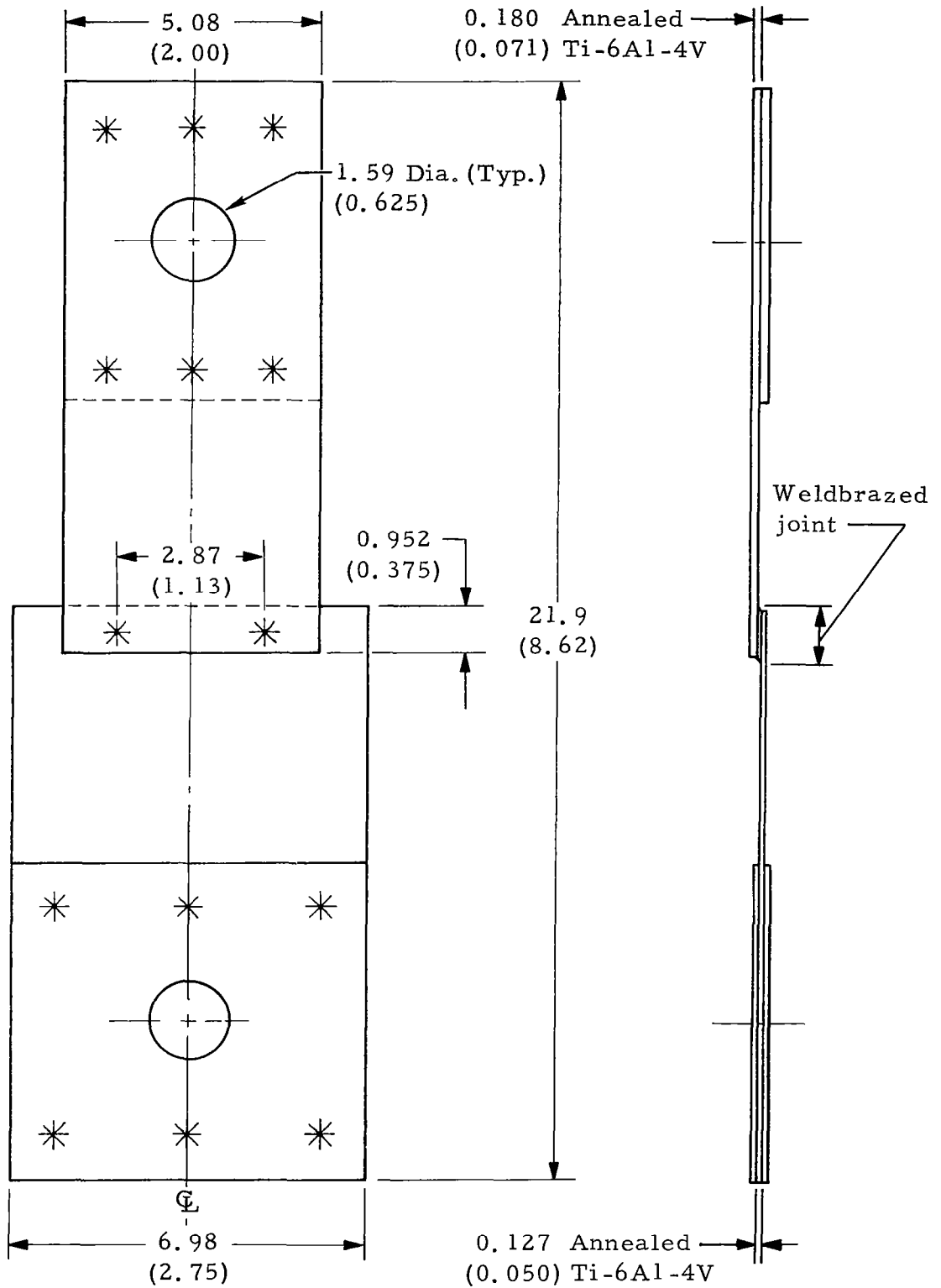

Figure 4. - Weldbraze lap shear specimen. Dimensions are given in centimeters (inches).

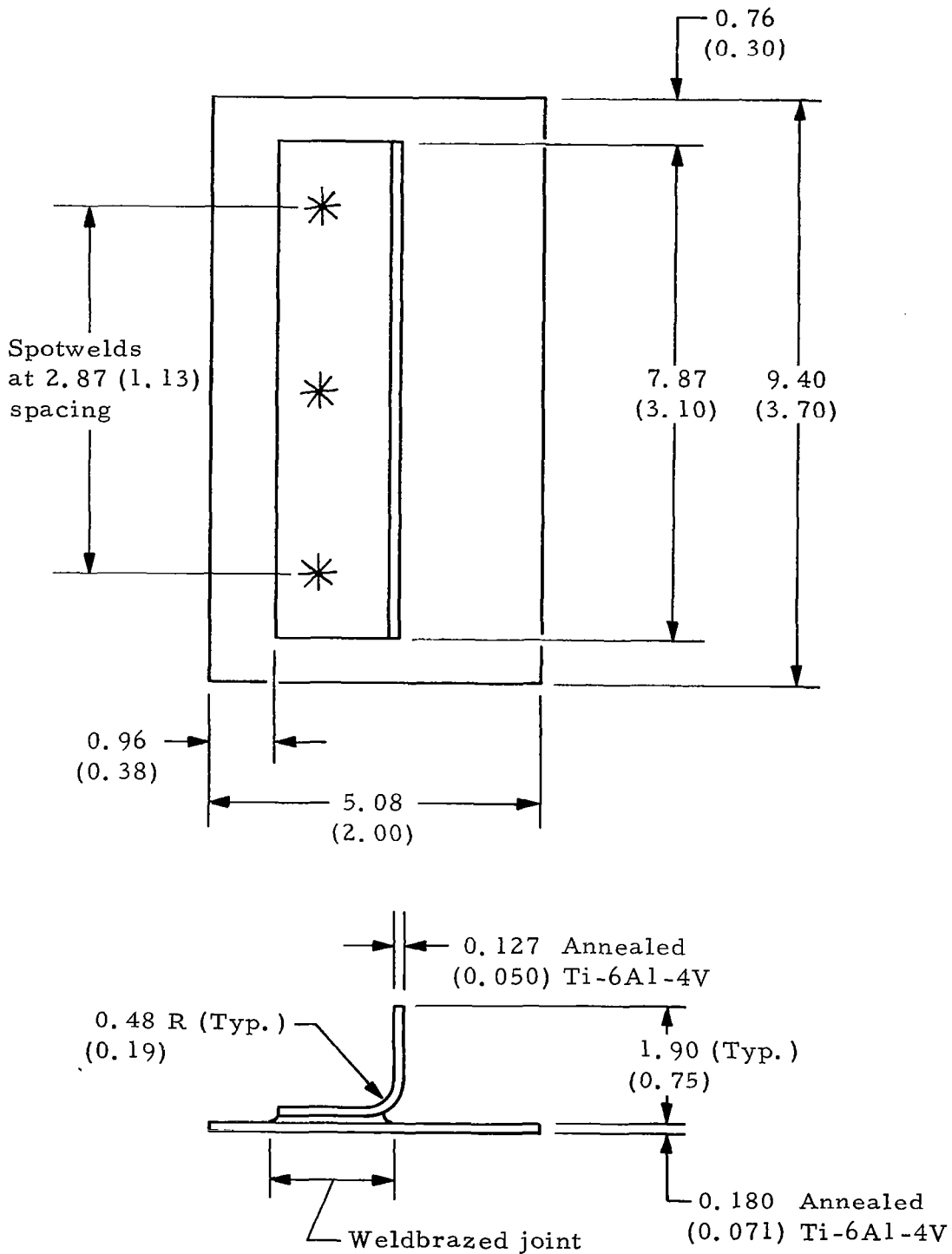

Figure 5. - Weldbrazed skin-angle quality control specimen.
Dimensions are given in centimeters (inches).

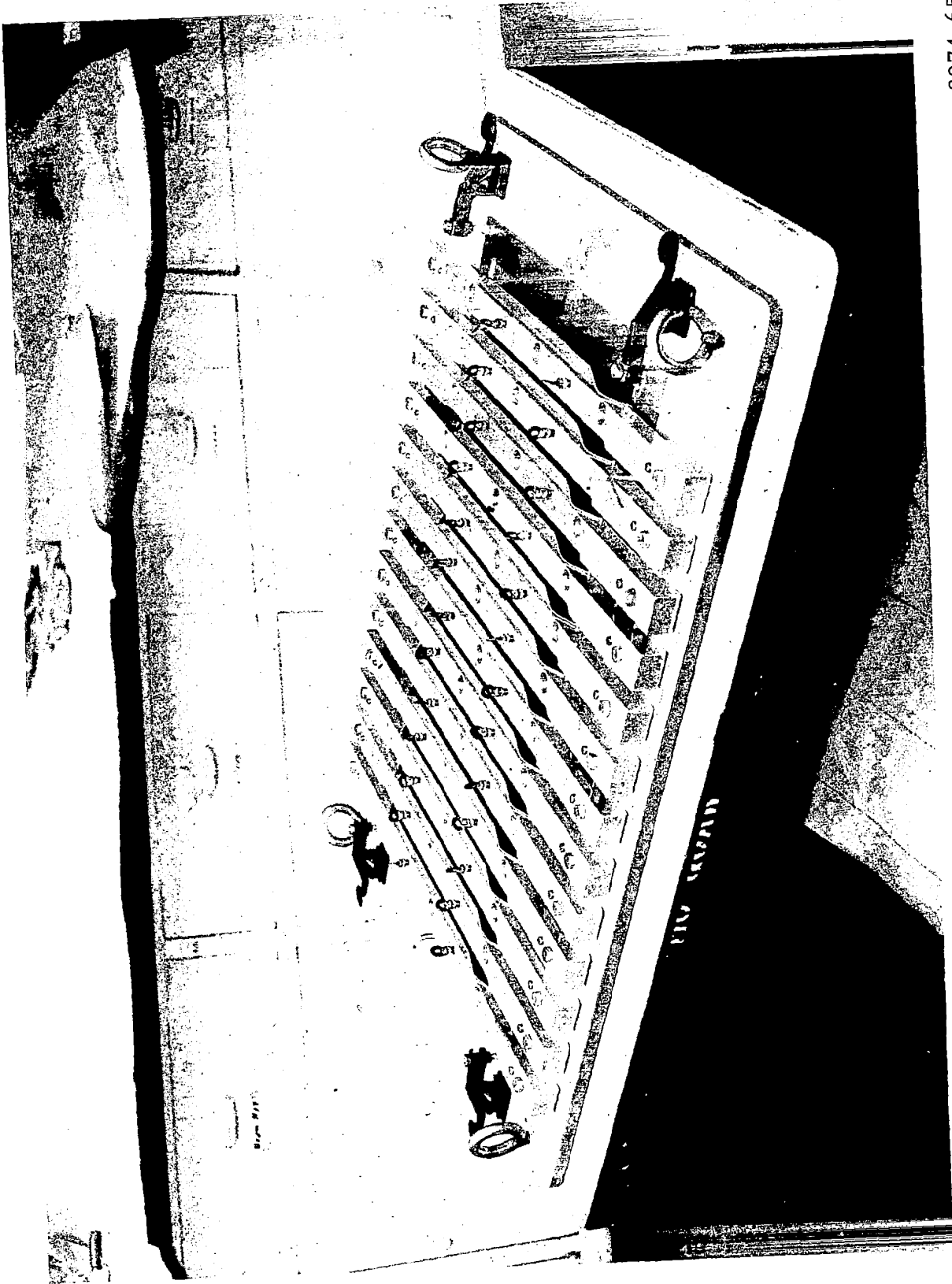

Figure 6. - Indexing of stiffeners on skin panel.

8974-65

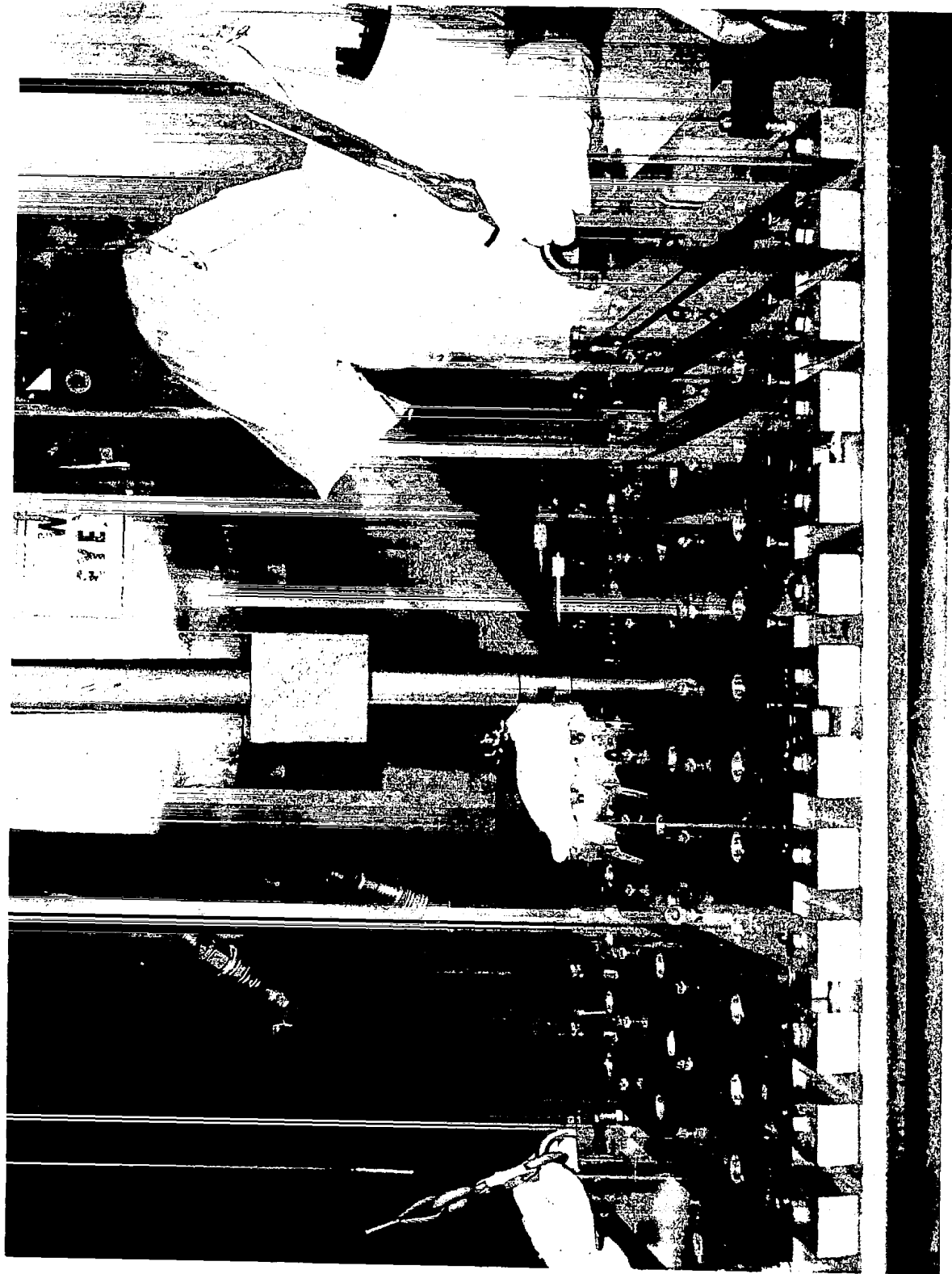

Figure 7. - Spotwelding of stiffeners to skin panel through access holes in index bars.

8974-115

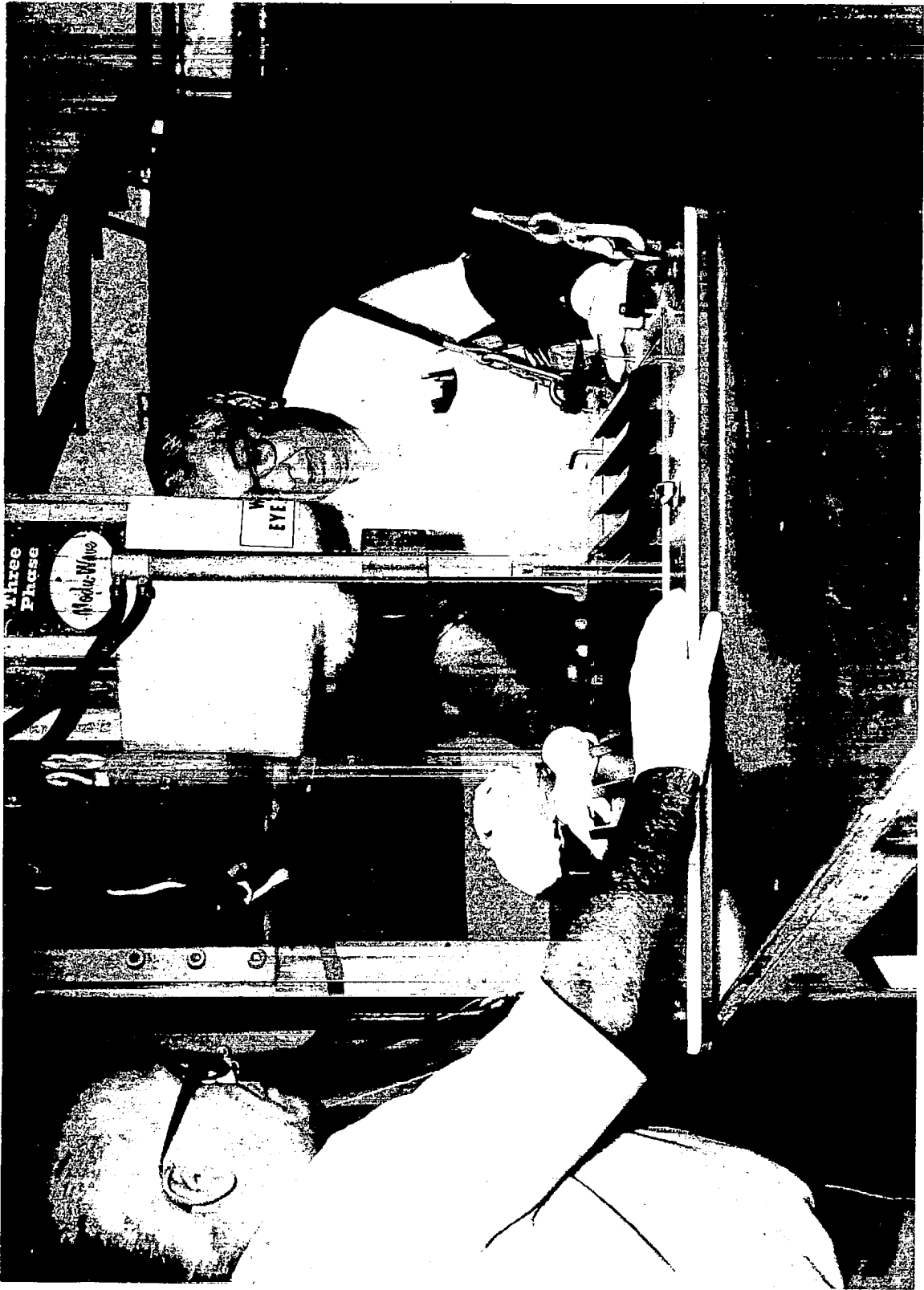

Figure 8. - Spotwelding of stiffeners to skin panel.

8974-75



8974-82

Figure 9. - Fixture for spotwelding of lap shear specimens.



Figure 10. - Fixture for spotwelding skin-angle quality control specimens.

8974-74

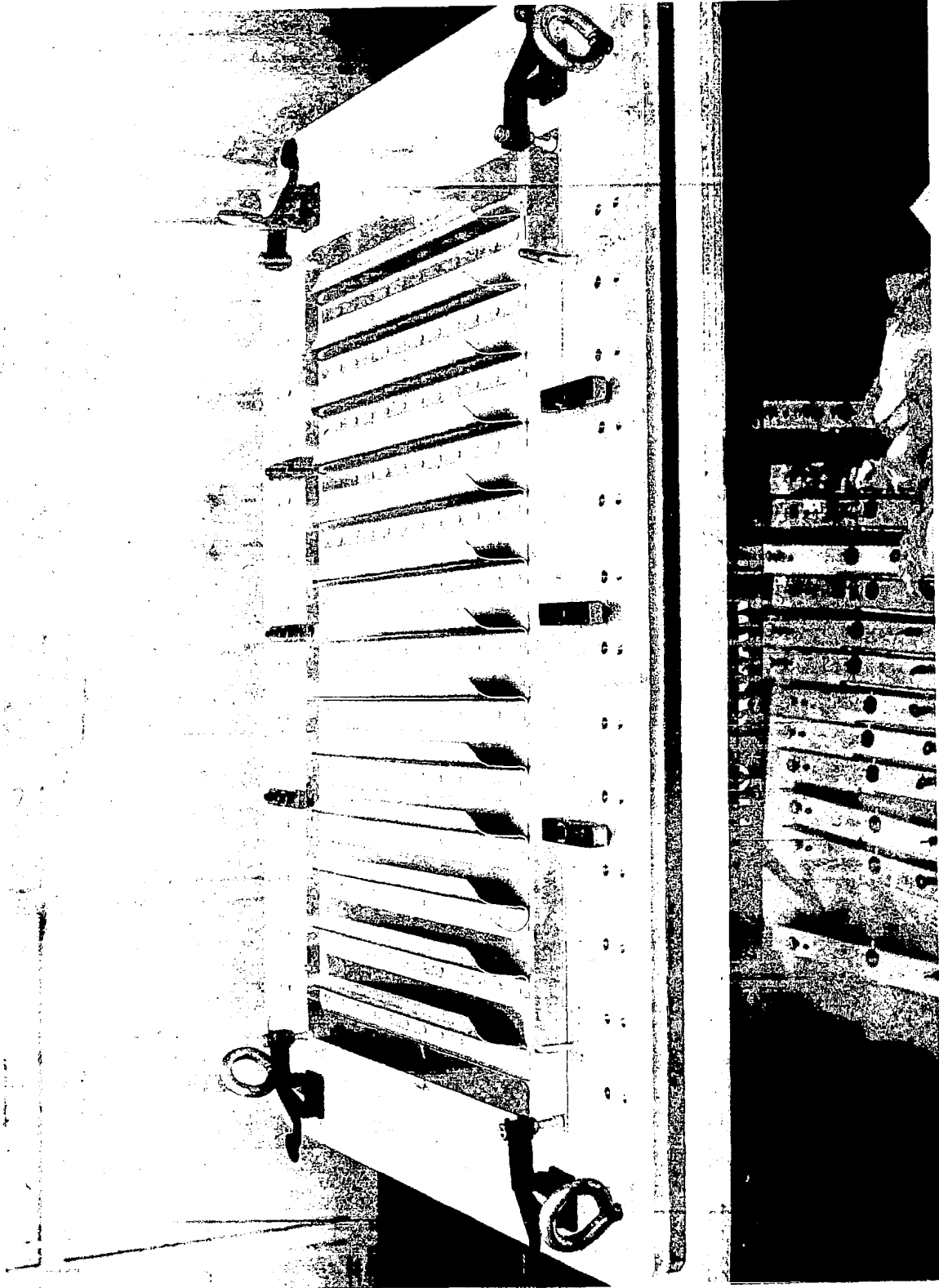

Figure 11. - Panel assembly with braze alloy strips installed.

8974-2

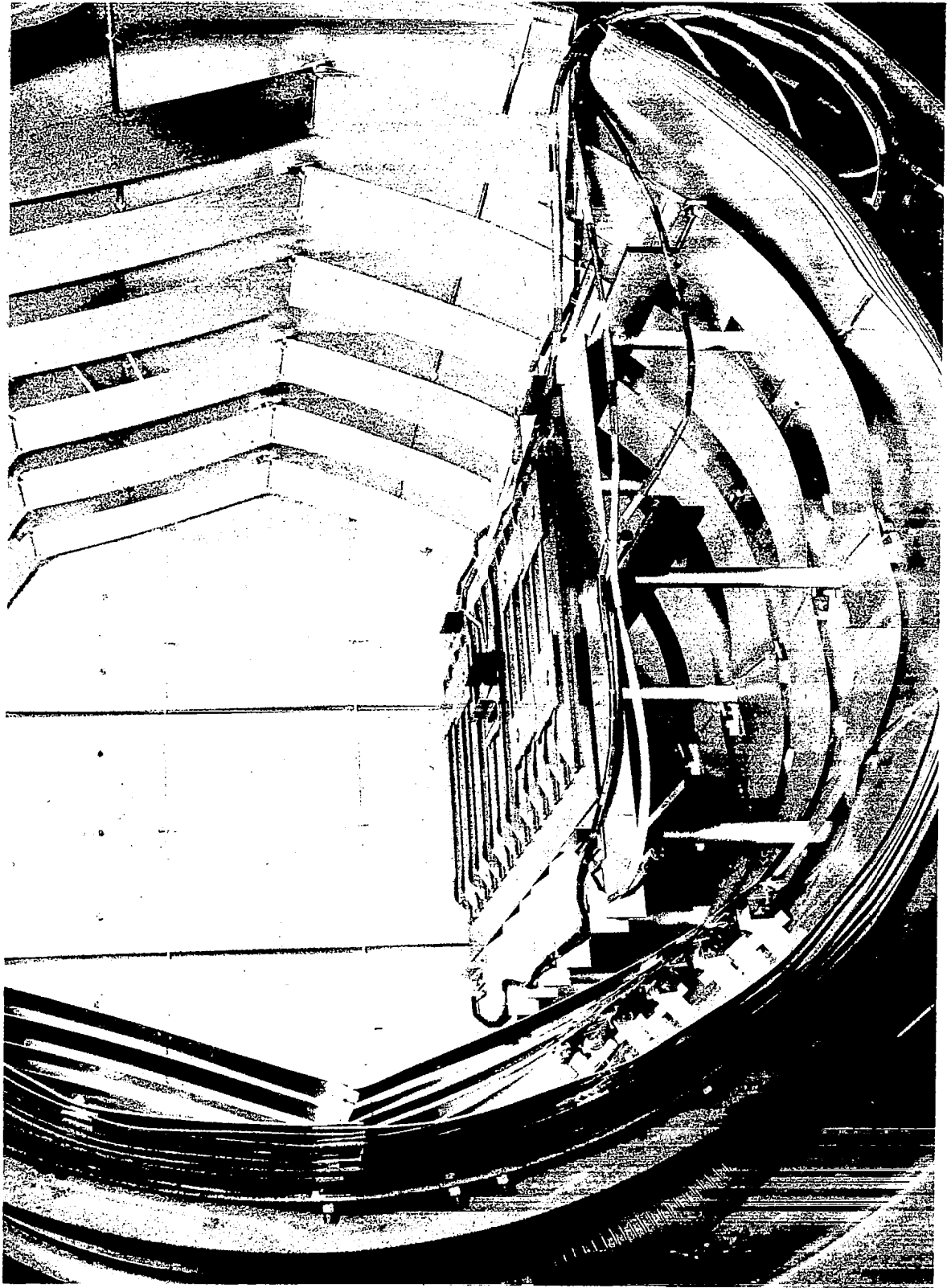

Figure 12. - Panel assembly, quality control specimens, and temperature monitoring assemblies, in vacuum furnace, prior to brazing. 8974-88

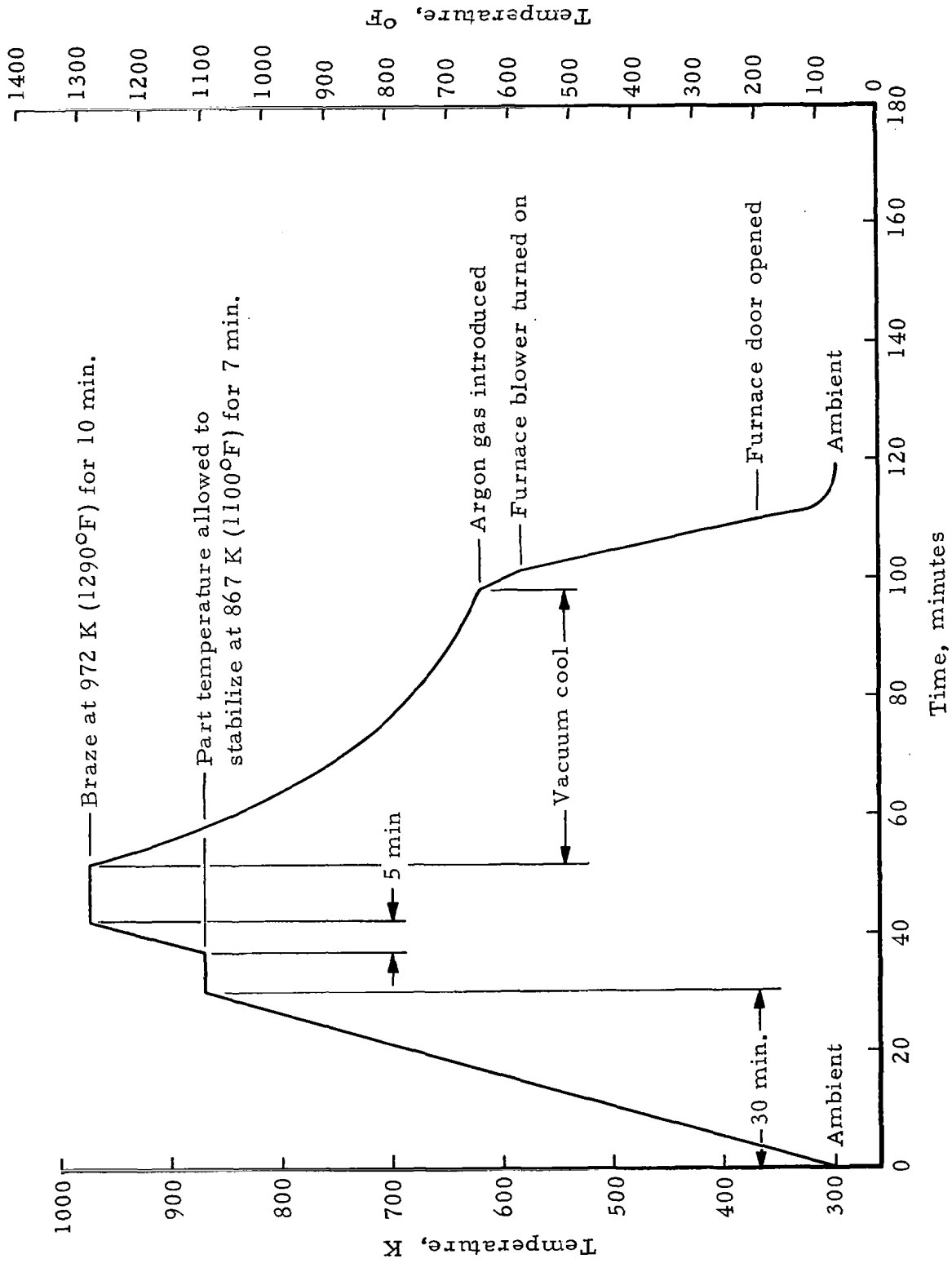

Figure 13. - Vacuum brazing cycle used for welded panels and specimens.

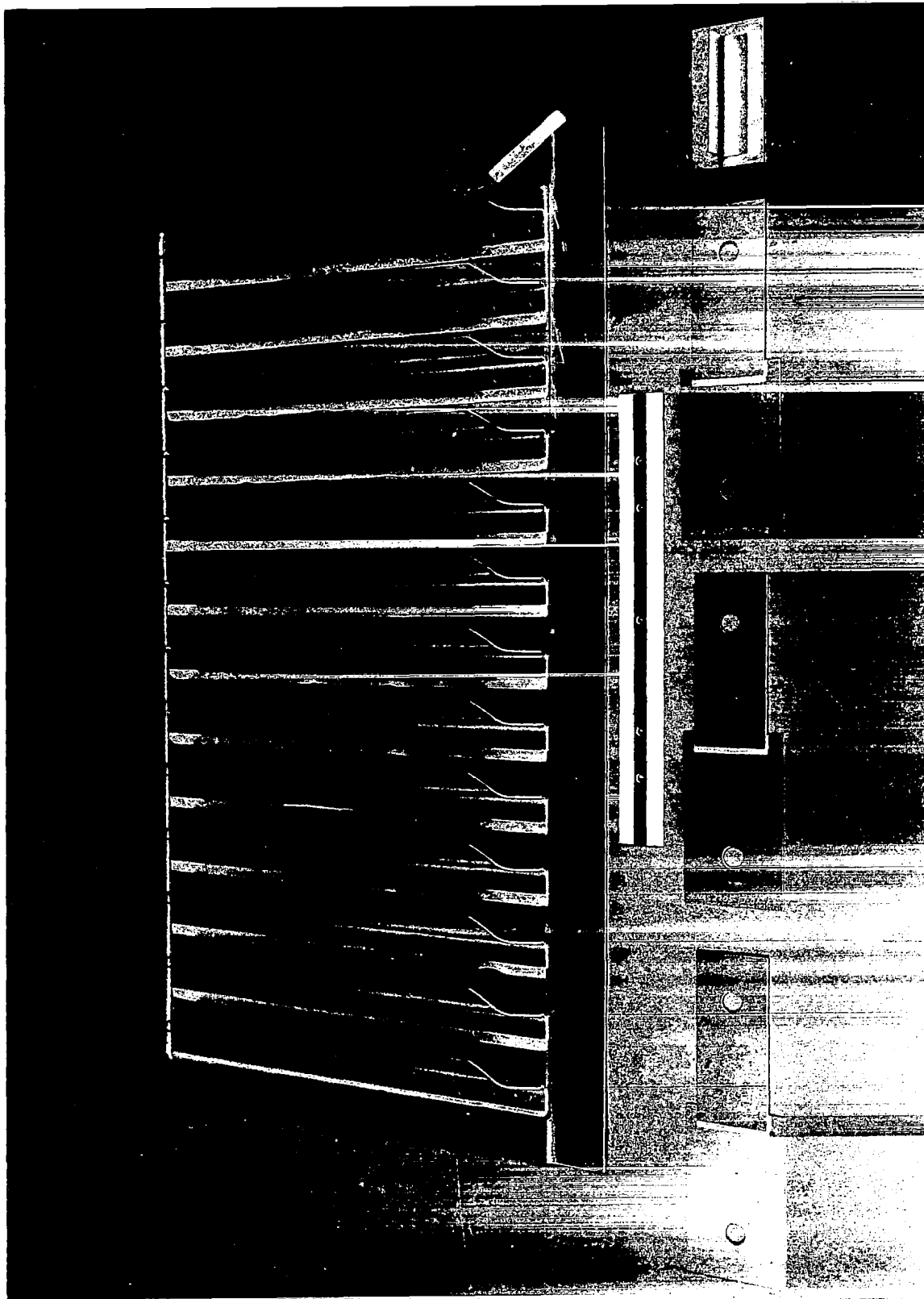
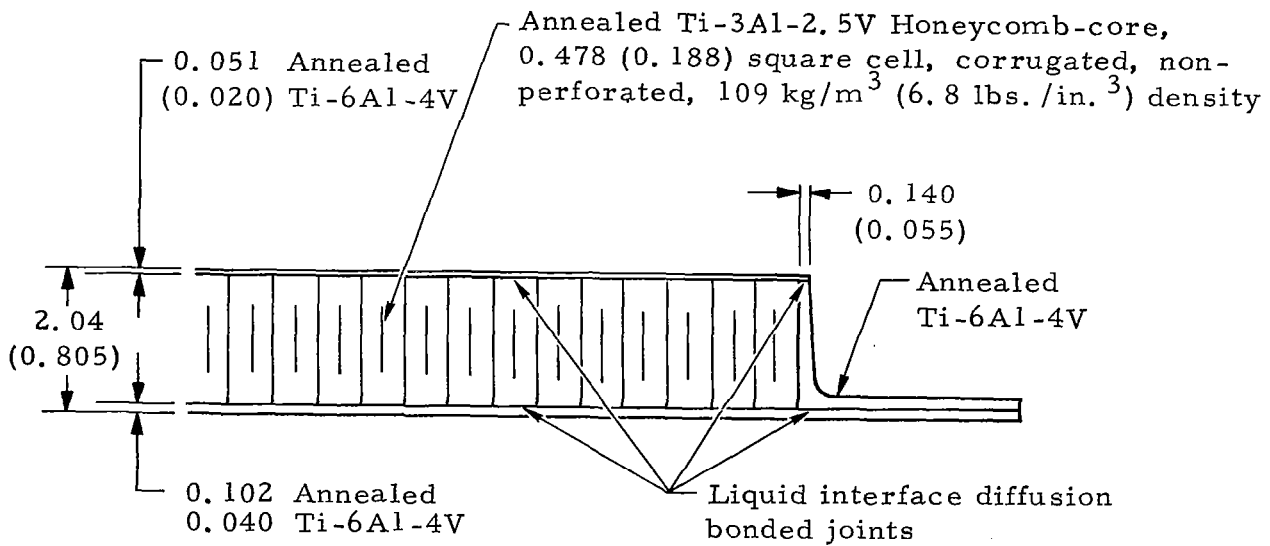
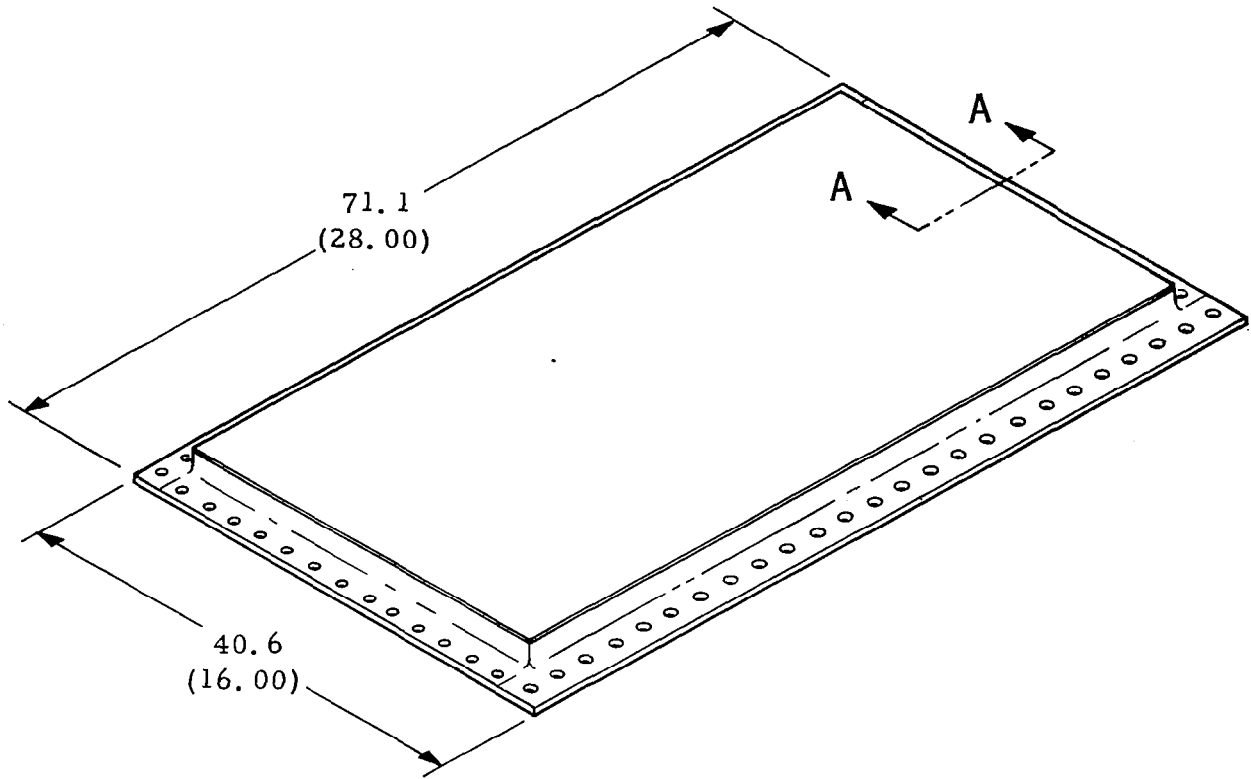
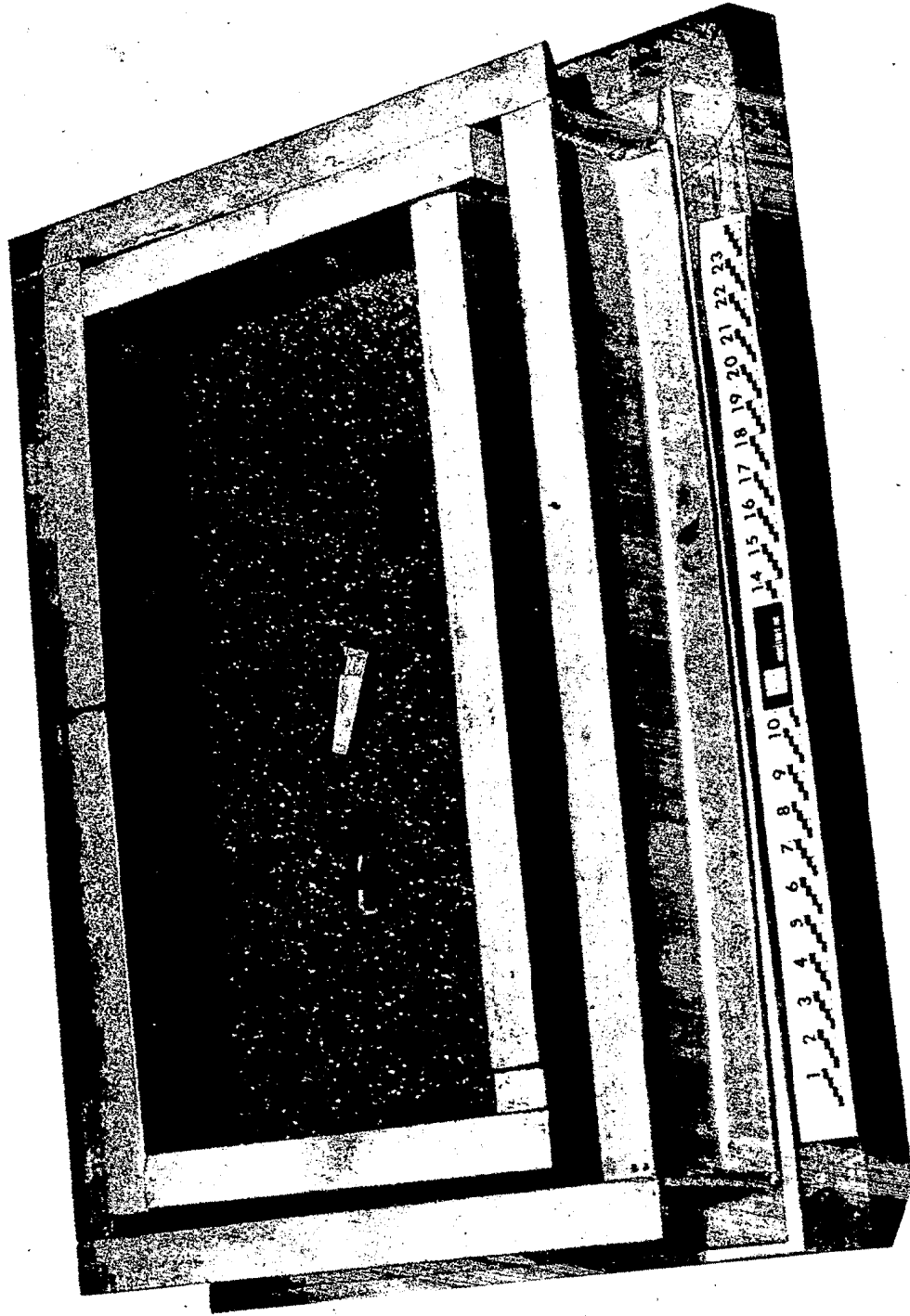

Figure 14. - Full-scale weldbrazed panel and quality control specimens.



Section A-A

Figure 15. - Configuration of full-scale diffusion bonded panel. Dimensions are given in centimeters (inches).



Steel in steel tooling frame, 75-5341-1

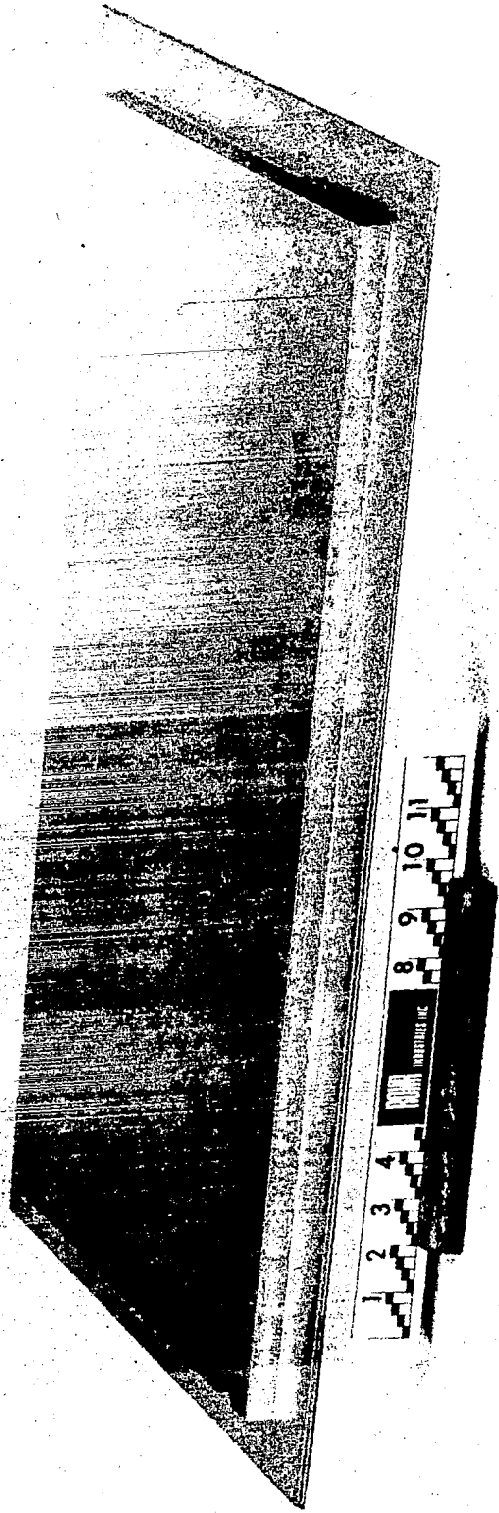

75-5341-4

Figure 17. - Full-scale diffusion bonded panel.

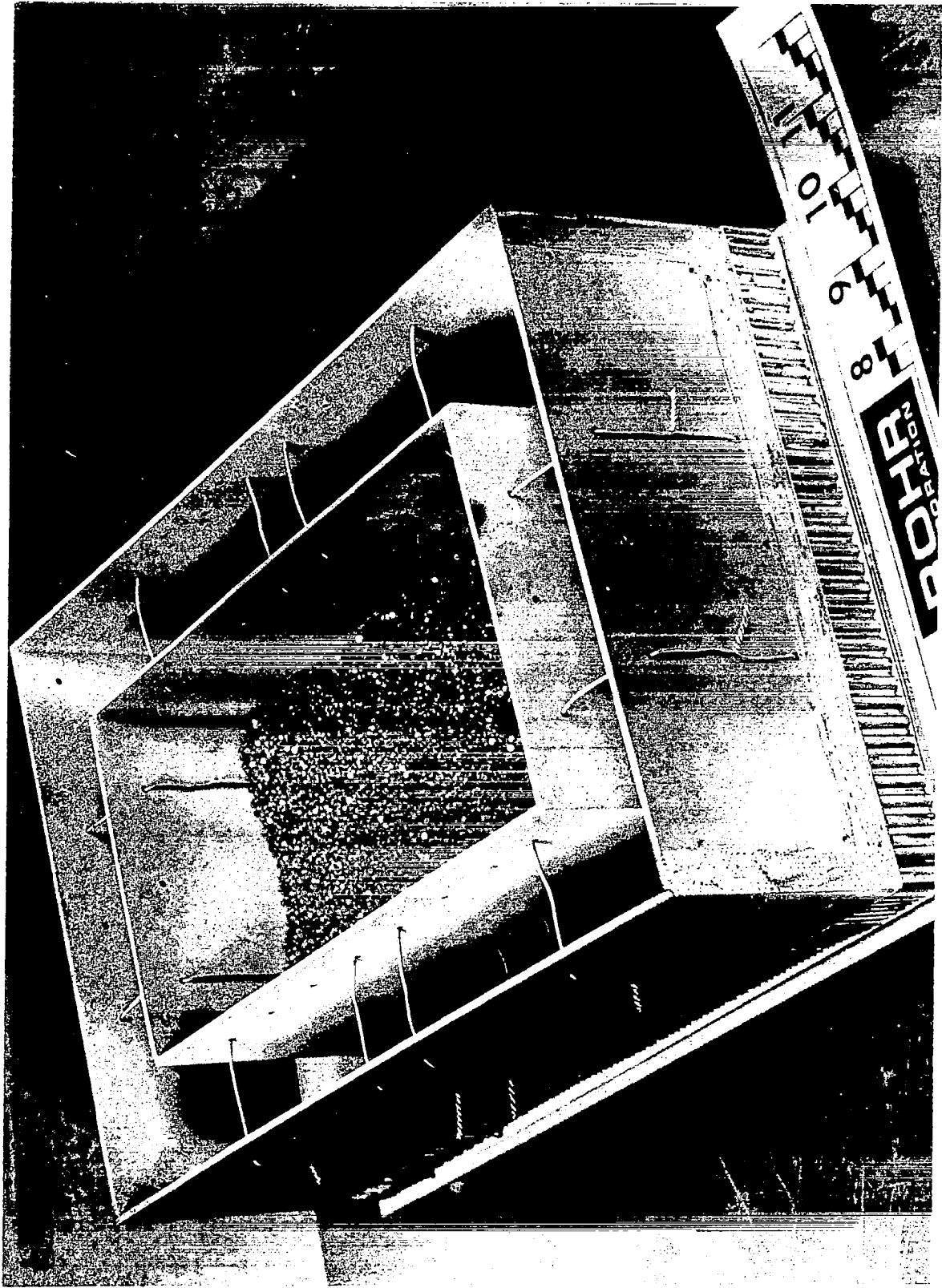
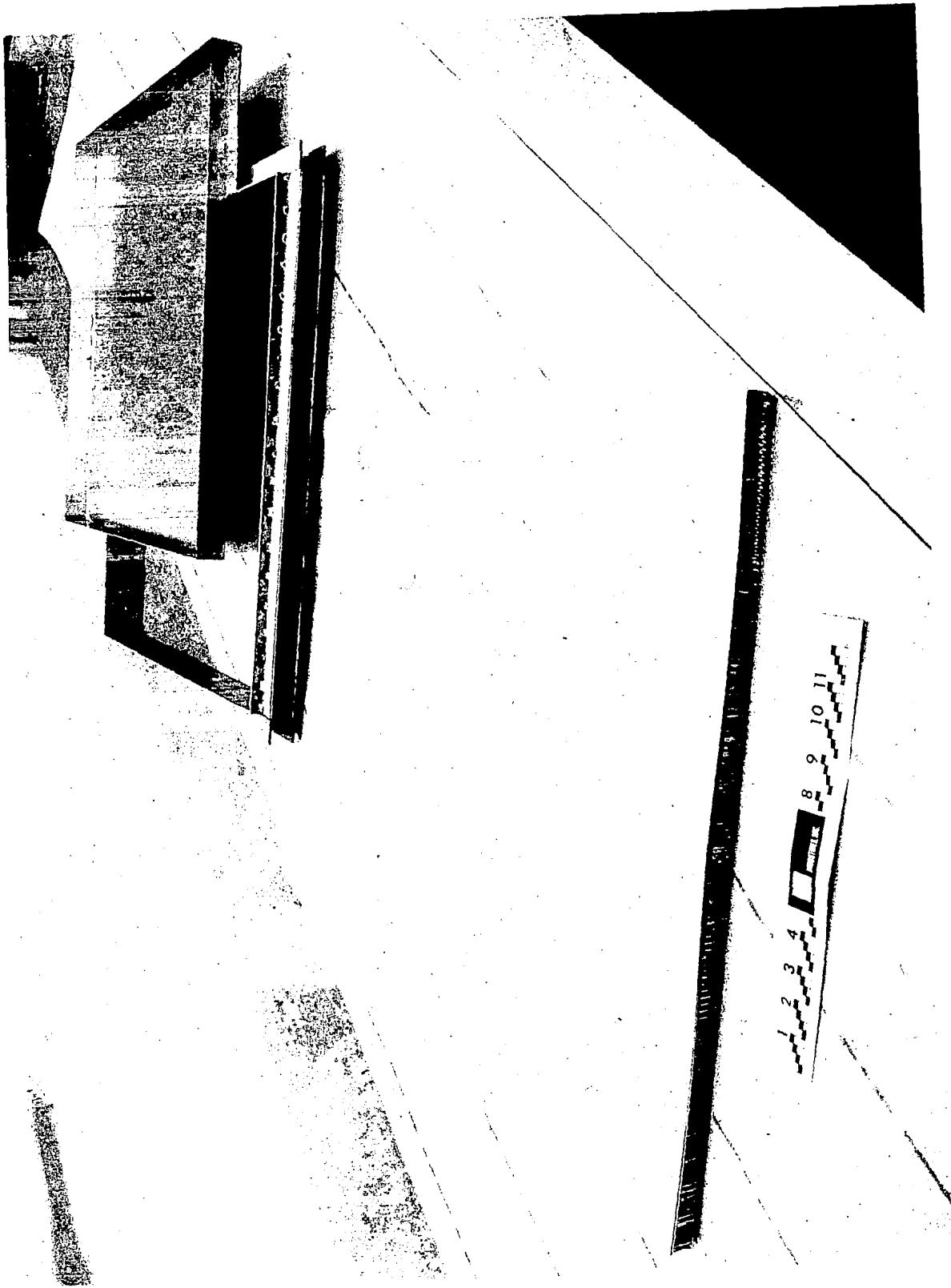

Figure 18. - Tooling used for sub-scale panels.

75-5341-2



75-5341-8

Figure 19. - Tooling and components of panel used for flatwise tension specimens.

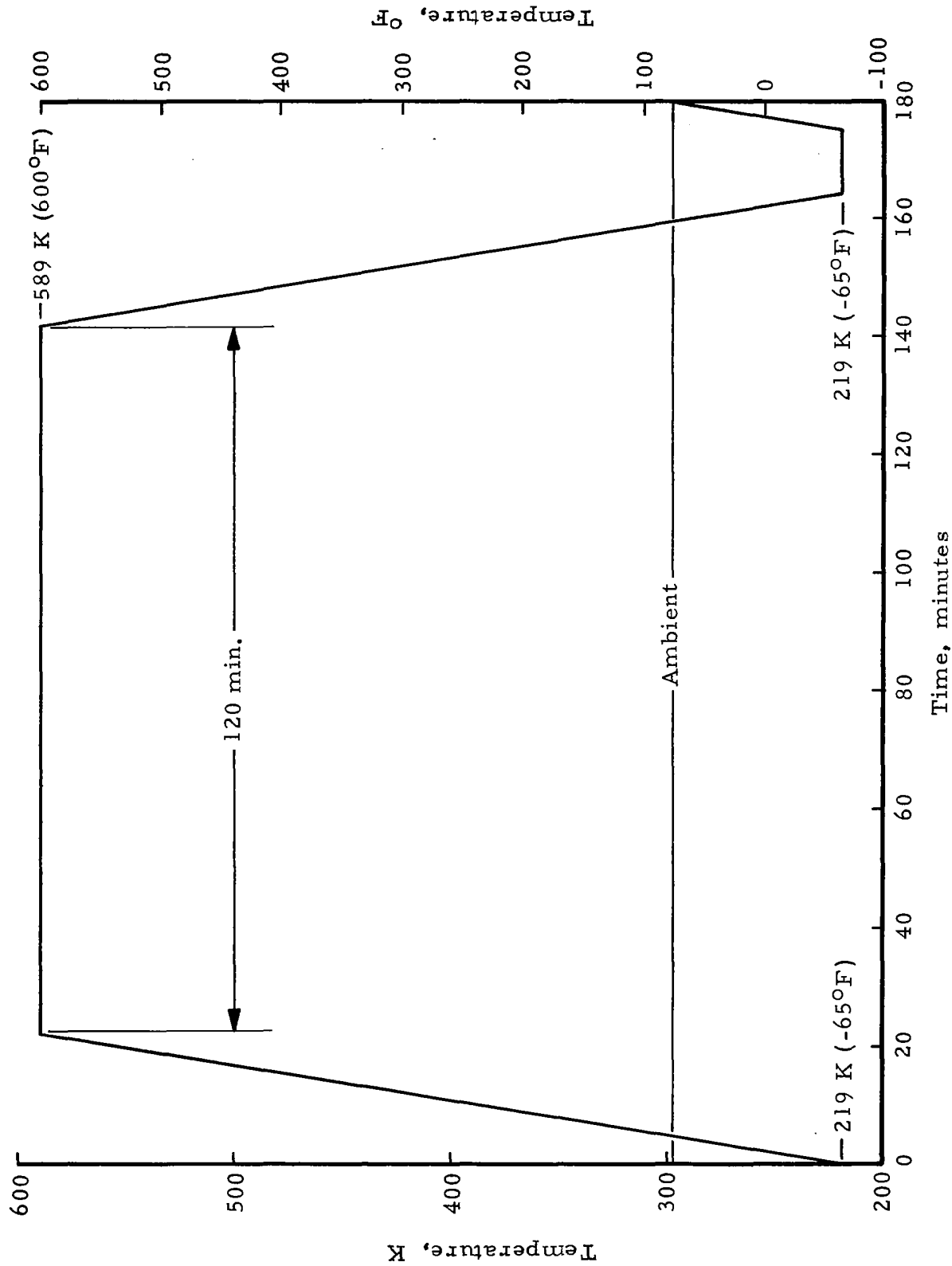
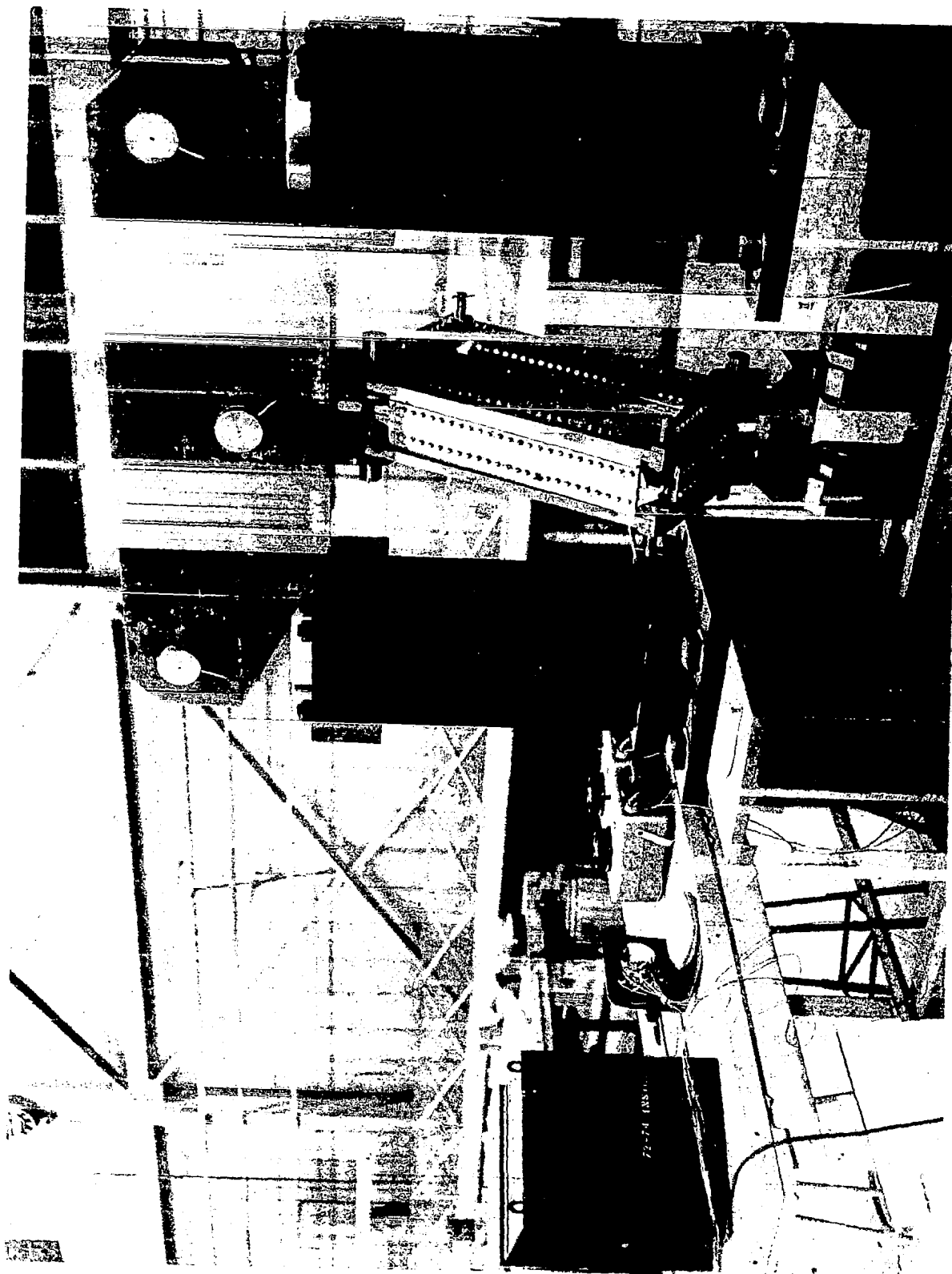
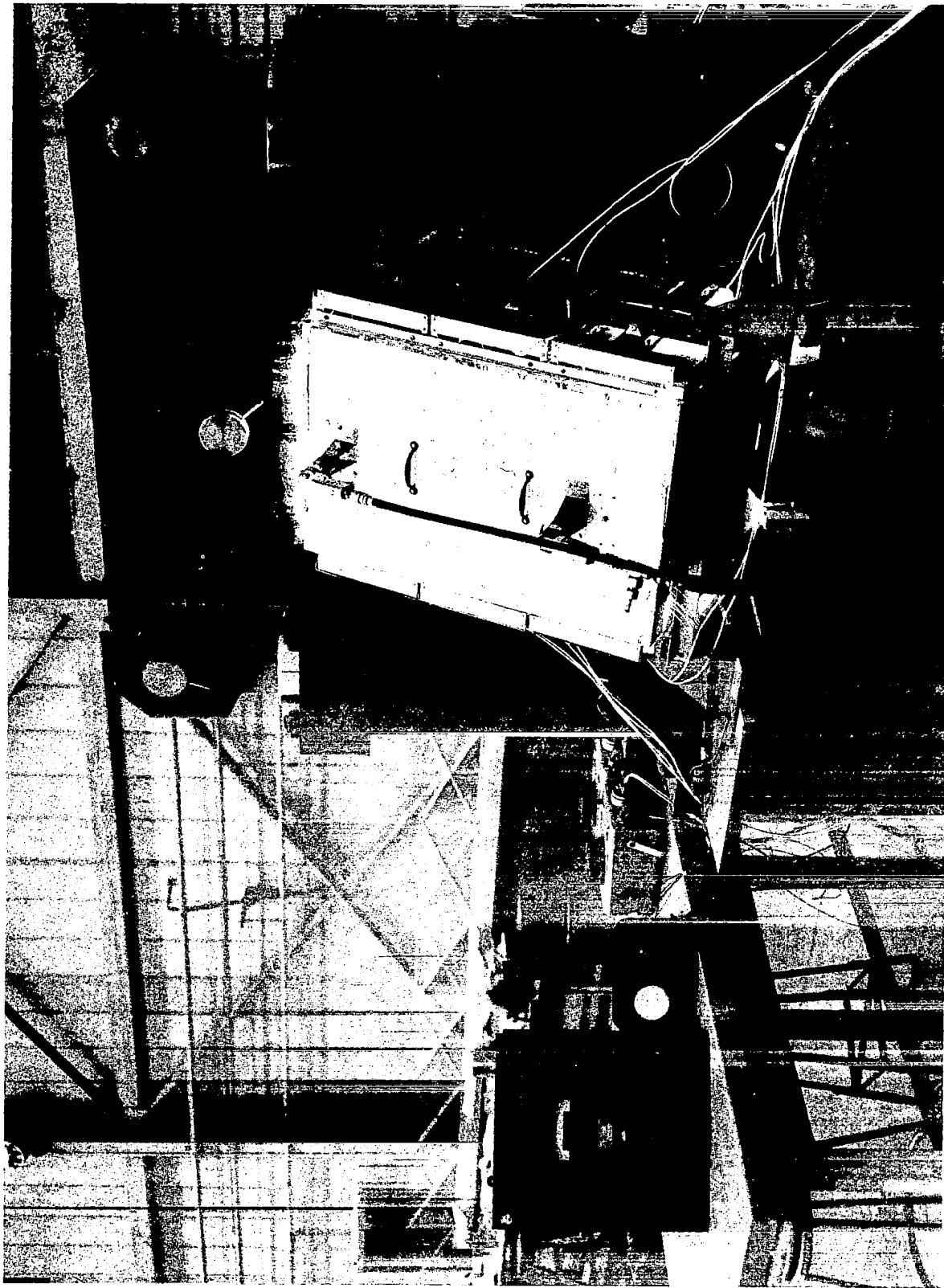

Figure 20. - Profile for thermal cycles from 219 K to 589 K (-65°F to 600°F).



C1157-3

Figure 21. - Ground test fixture for full-scale panels.



C1157-4
Figure 22. - Ground test fixture with oven installed for tests at 589 K (600°F).

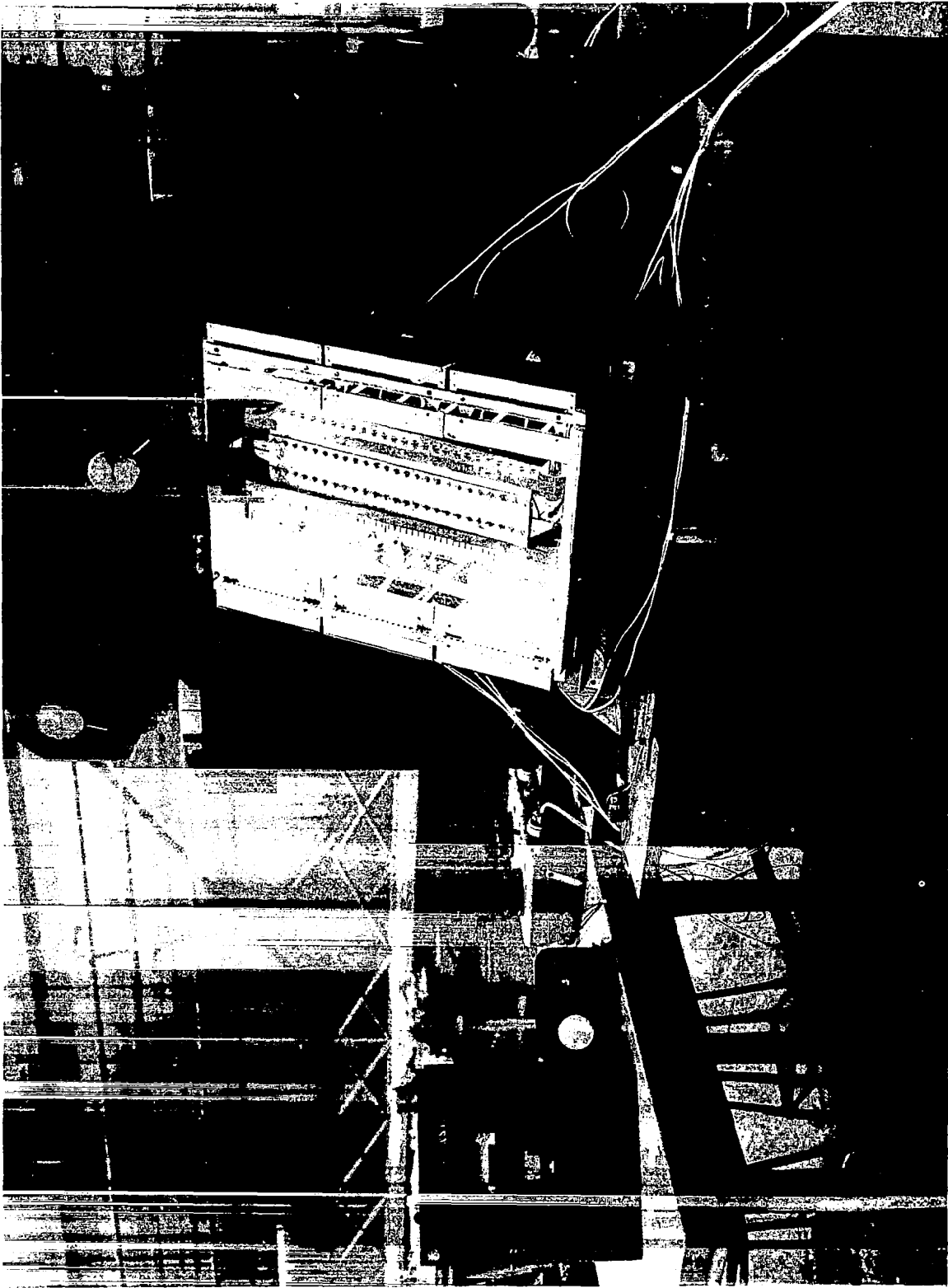

Figure 23. - Ground test fixture with one wall of oven removed to show heat lamp arrangement. C1157-2

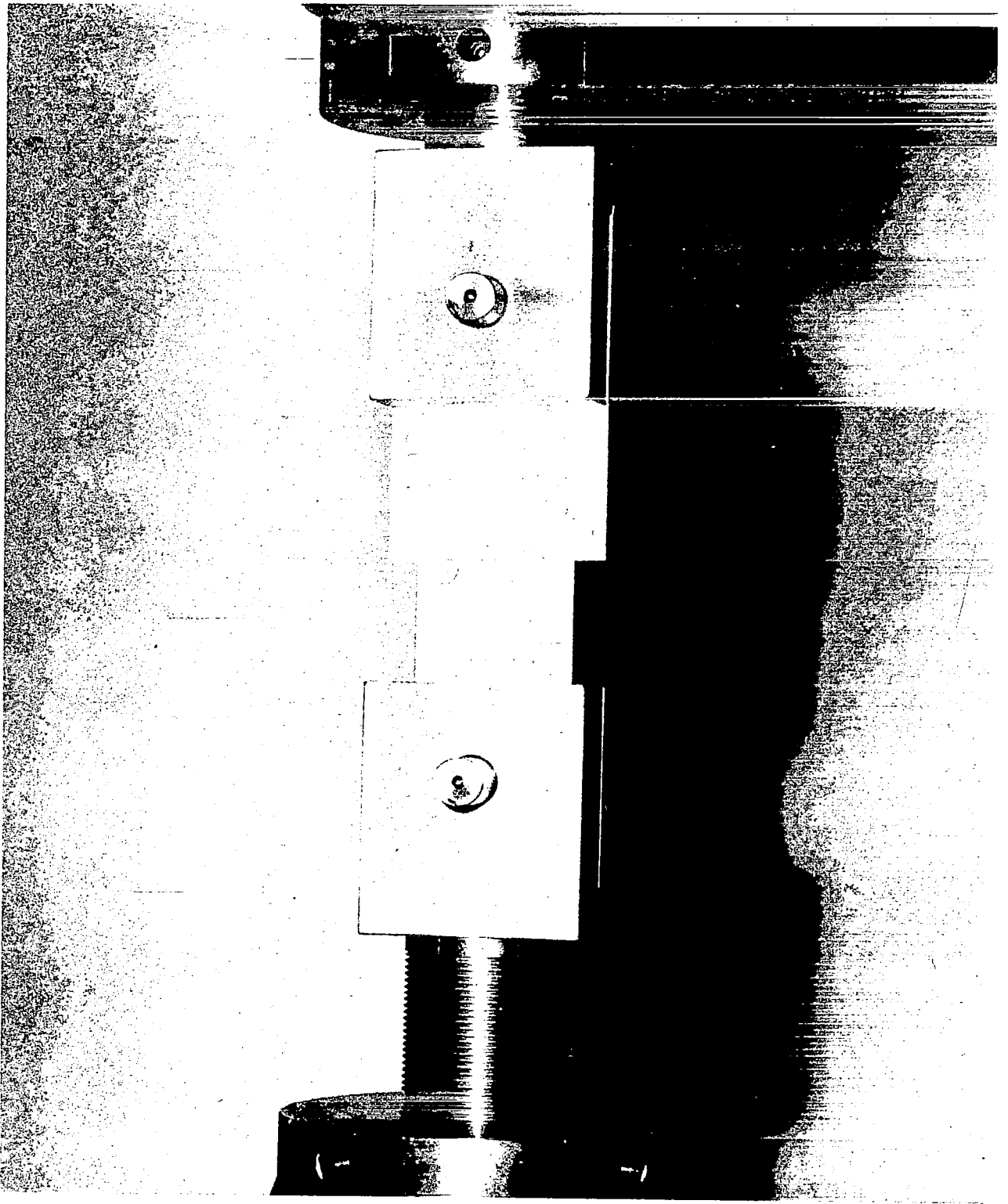

Figure 24. - Testing arrangement for weldbrazed lap shear specimens. 74-5065-1

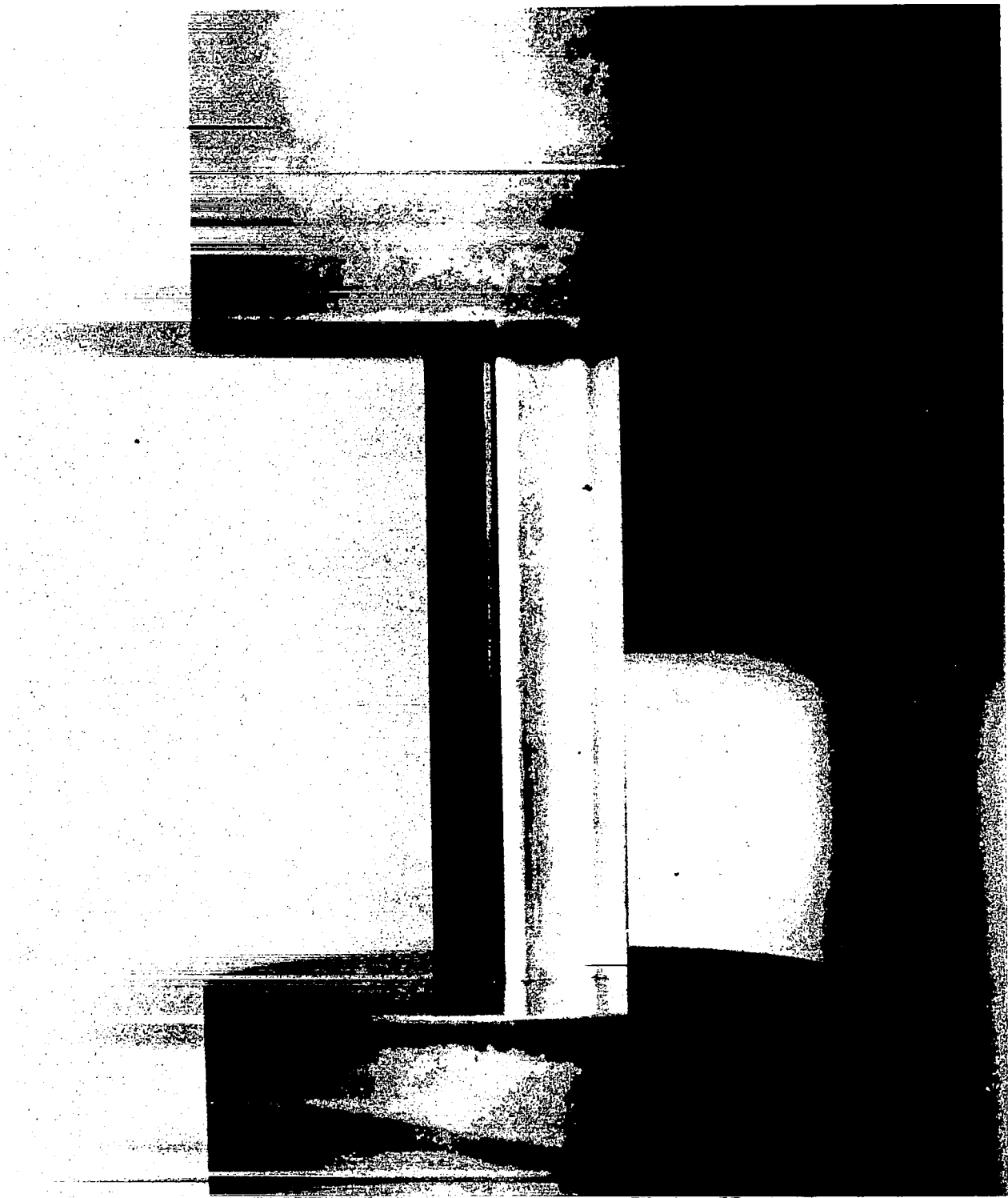

Figure 25. - Arrangement for testing of weldbrazed 74-5065-2
compression specimens.

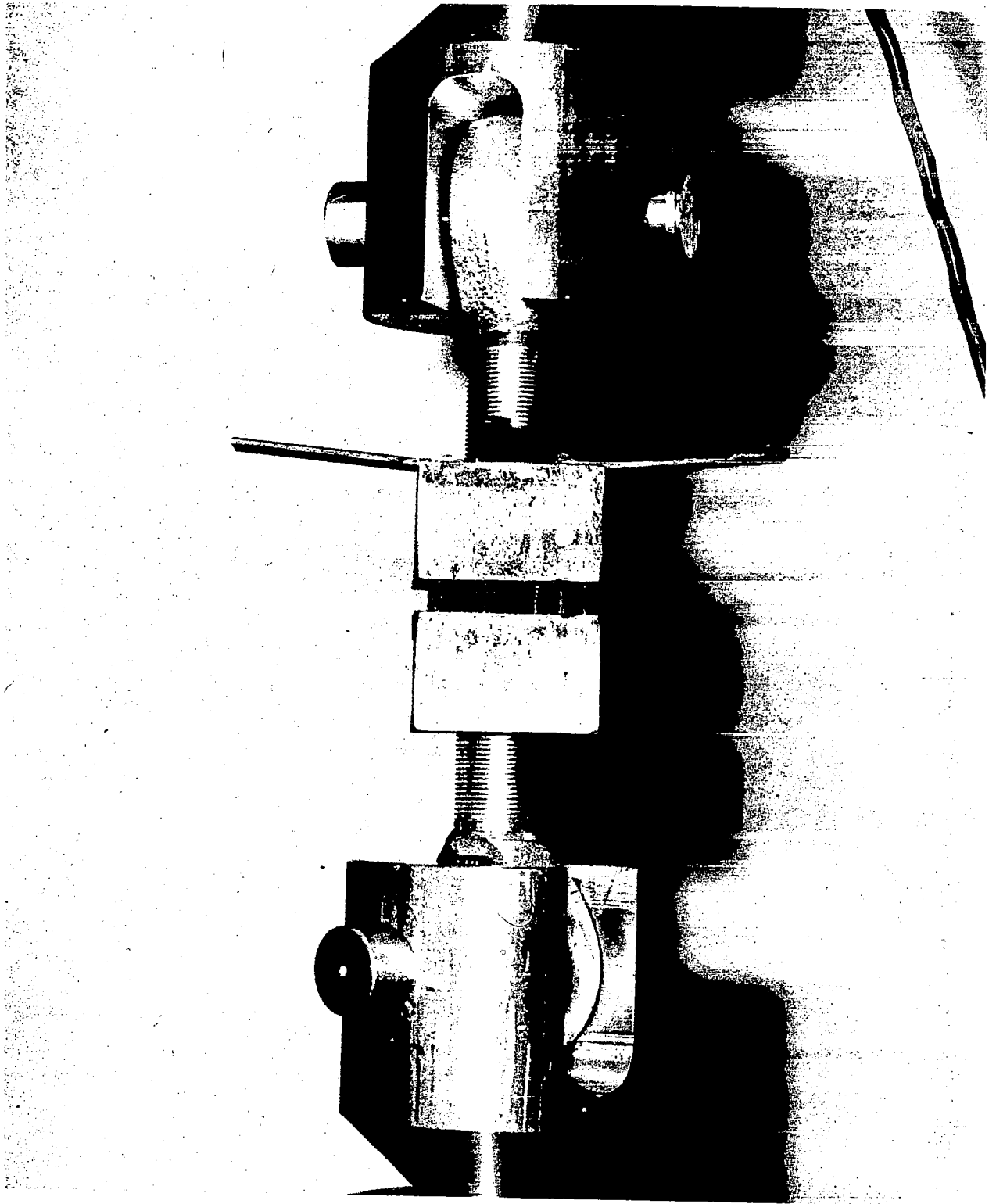

Figure 26. - Arrangement for testing of diffusion bonded flatwise tension specimens.

74-5065-3

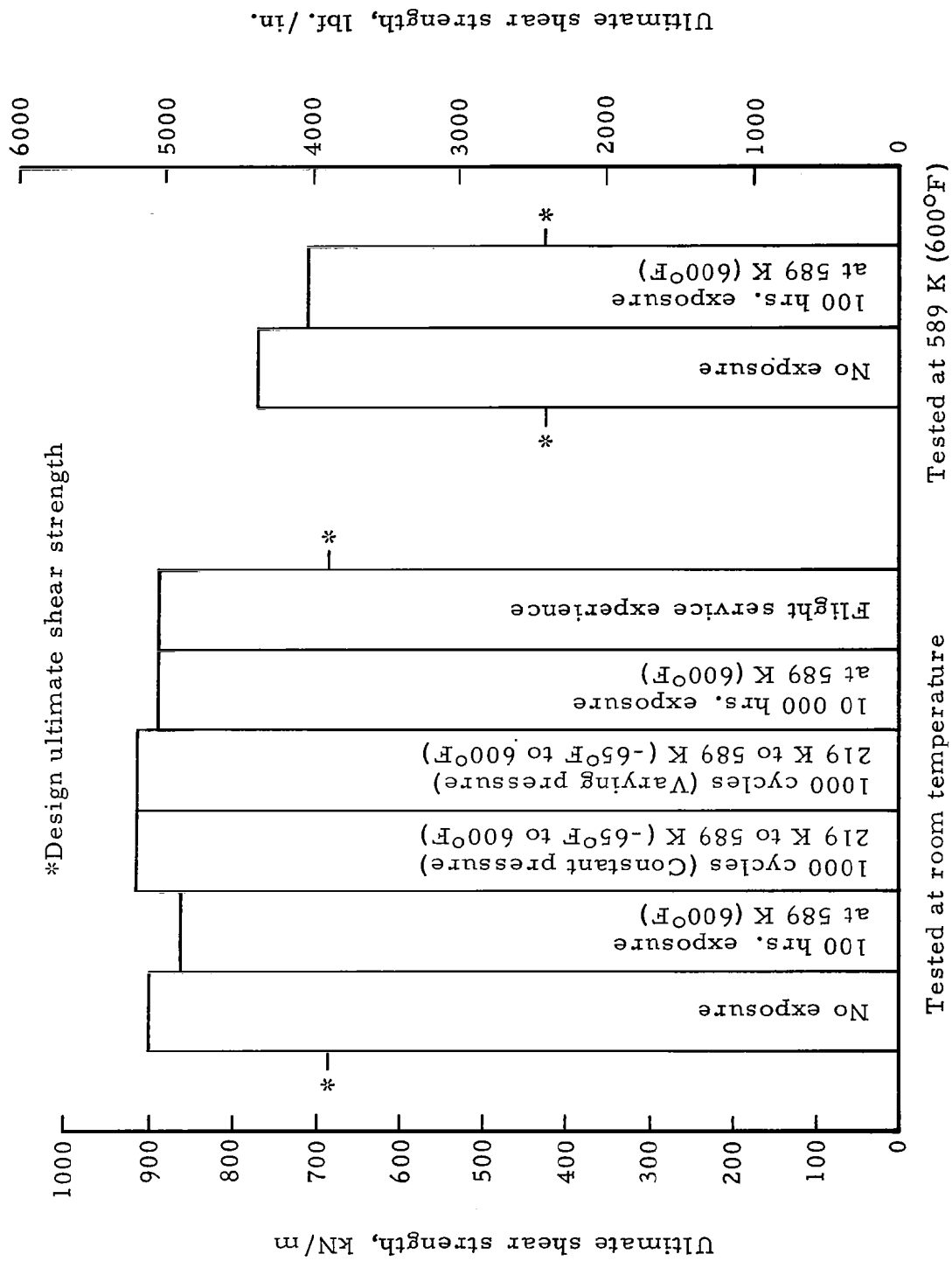
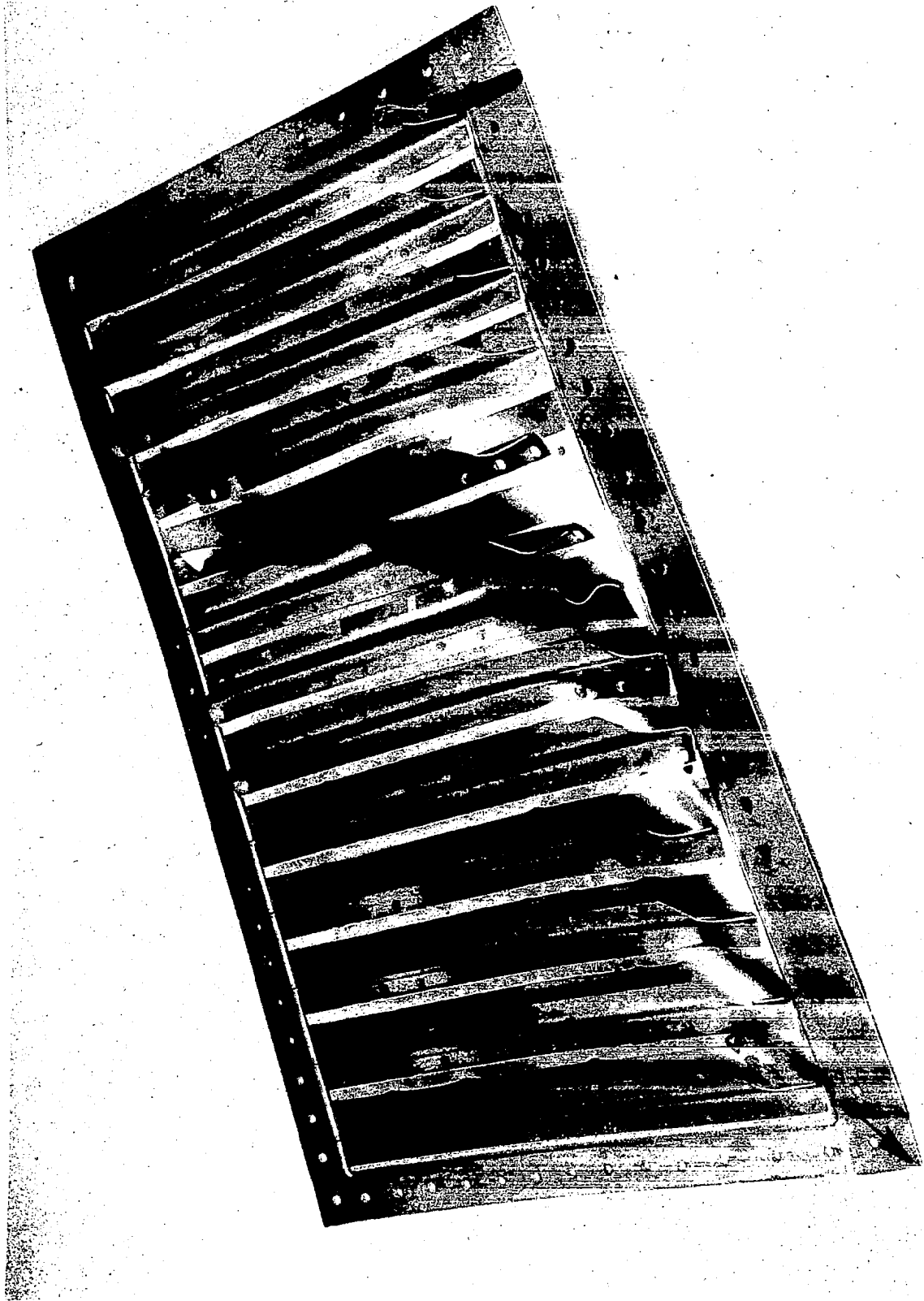

Figure 27. - Shear strength of welded panels.



9039-14

Figure 28. - Typical failure of welded panel tested at room temperature. Interior surface of panel.

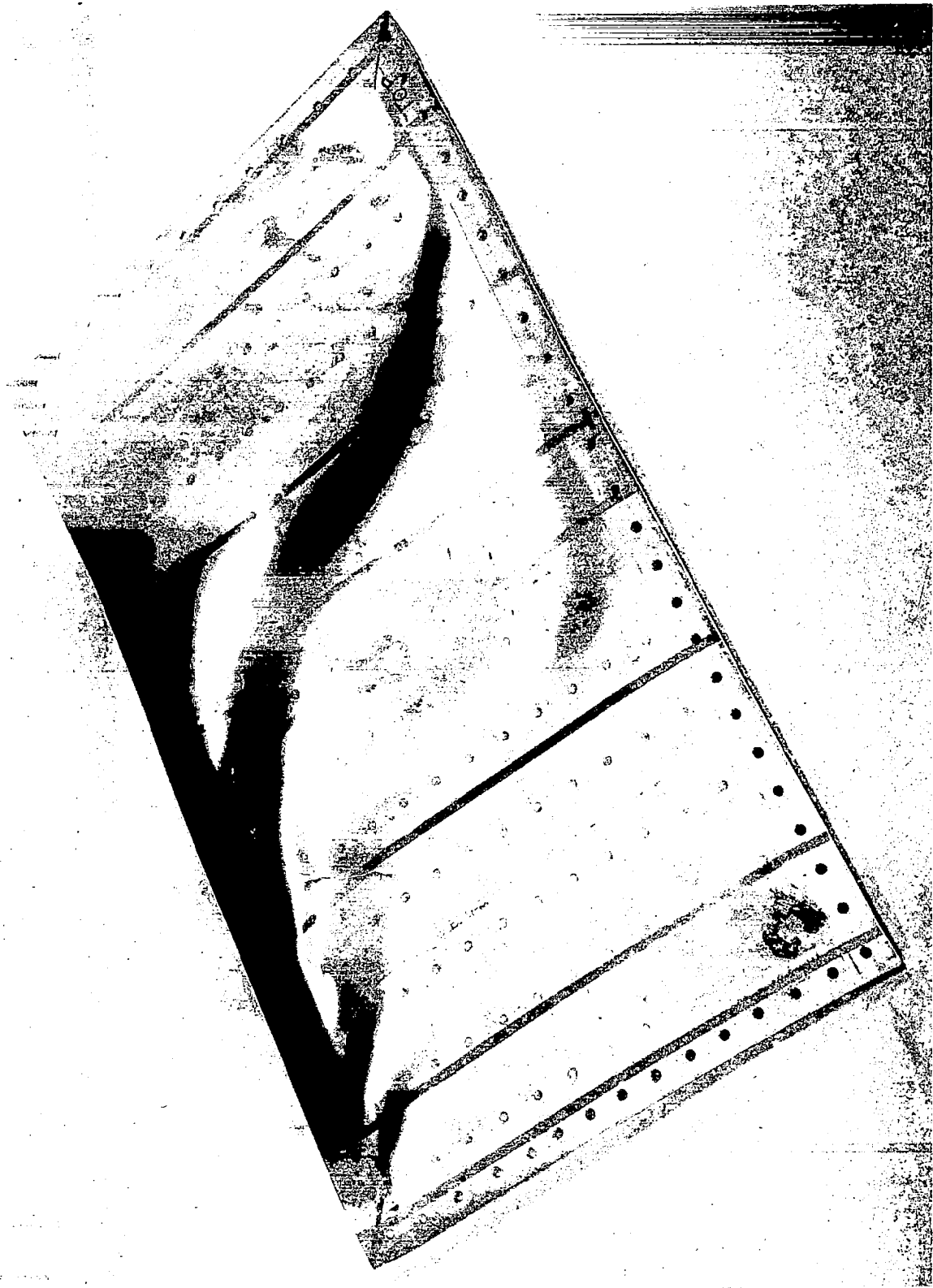

Figure 29. - Typical failure of welded panel tested at room temperature. Exterior surface of panel.

9039-15

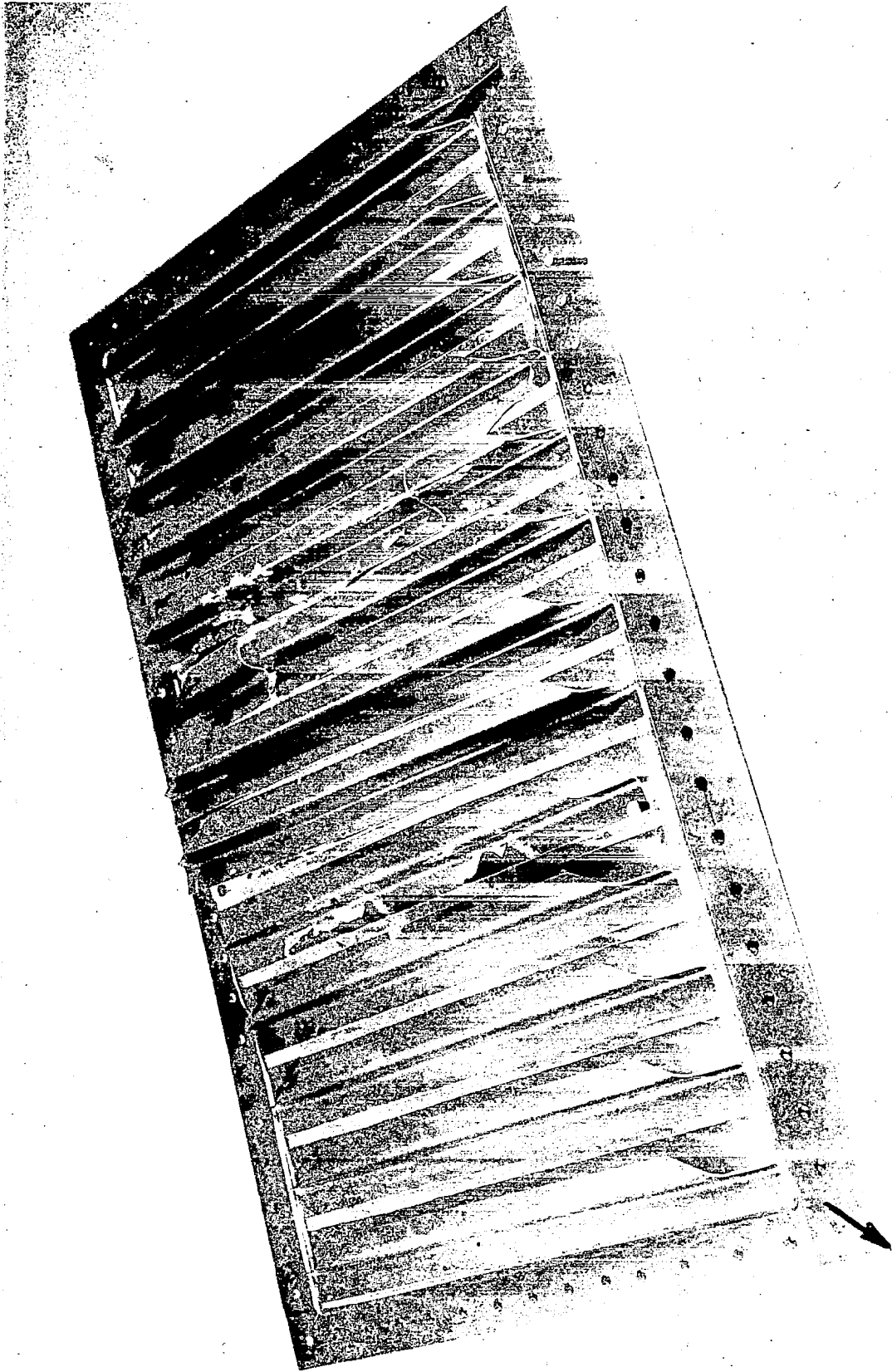
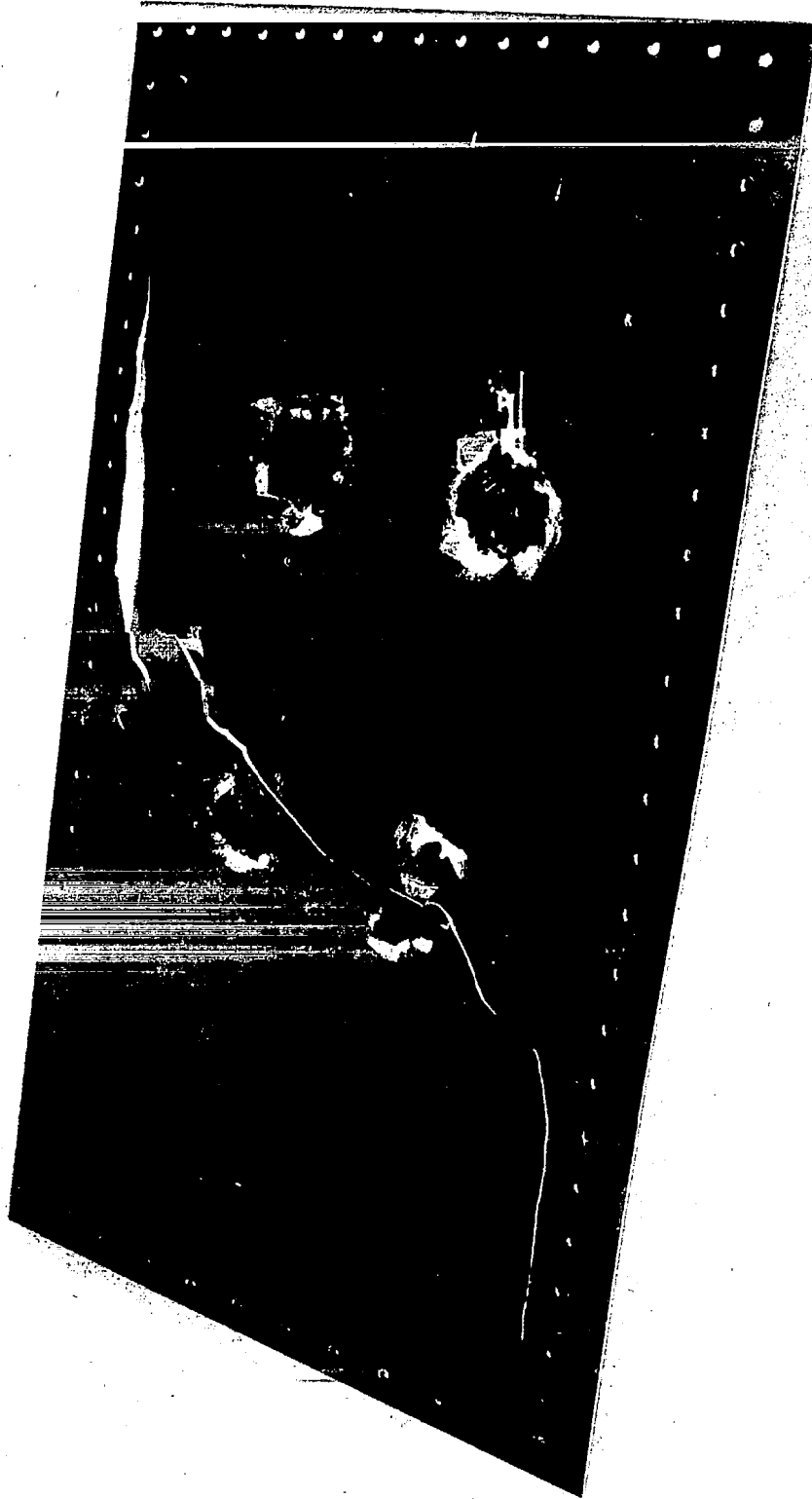

Figure 30. - Typical failure of weldbrazed panel tested at 589 K (600°F).
Interior surface of panel.

9065-12



9065-11

Figure 31. - Typical failure of weldbrazed panel tested at 589 K (600°F).
Exterior surface of panel.

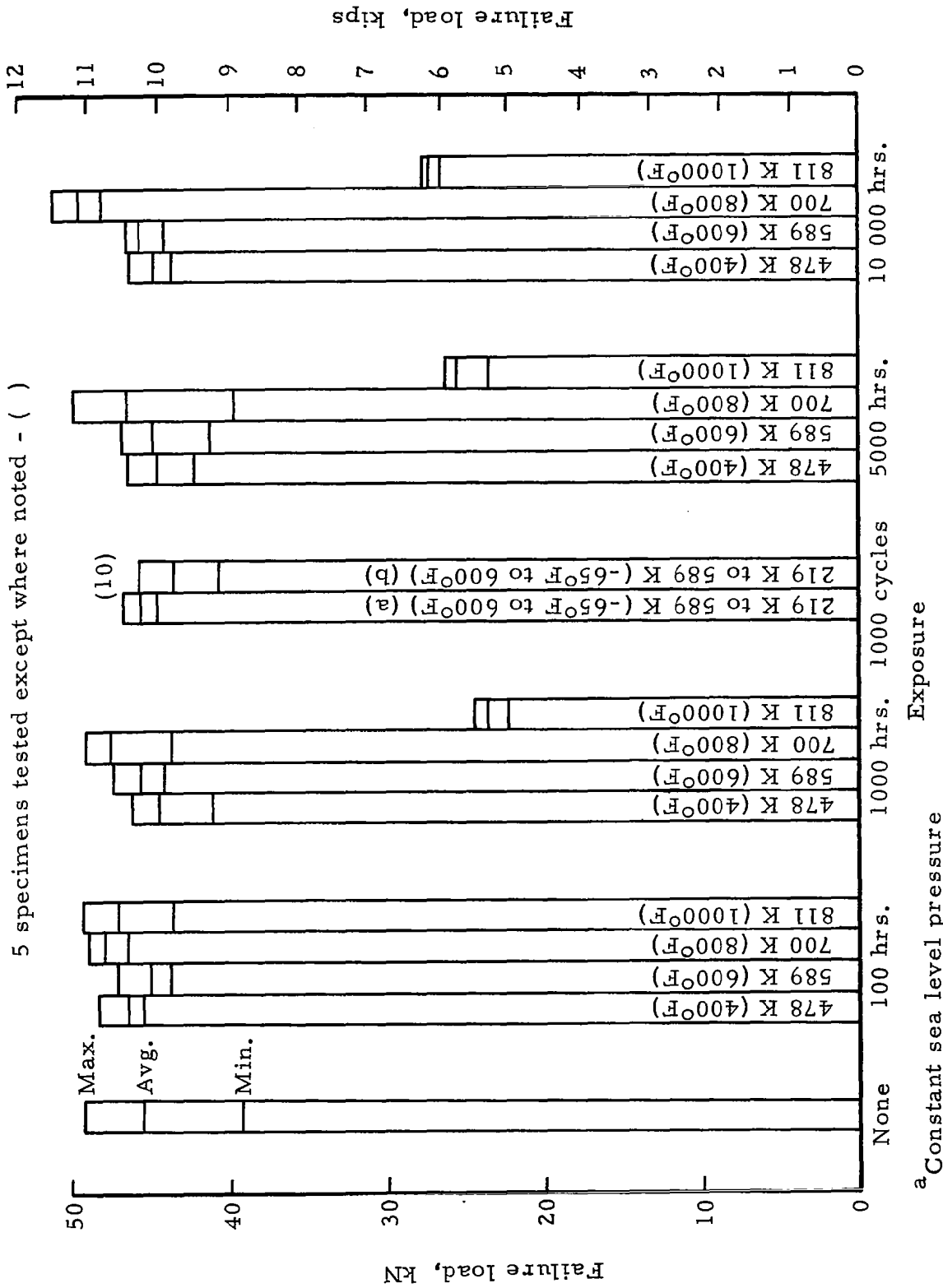
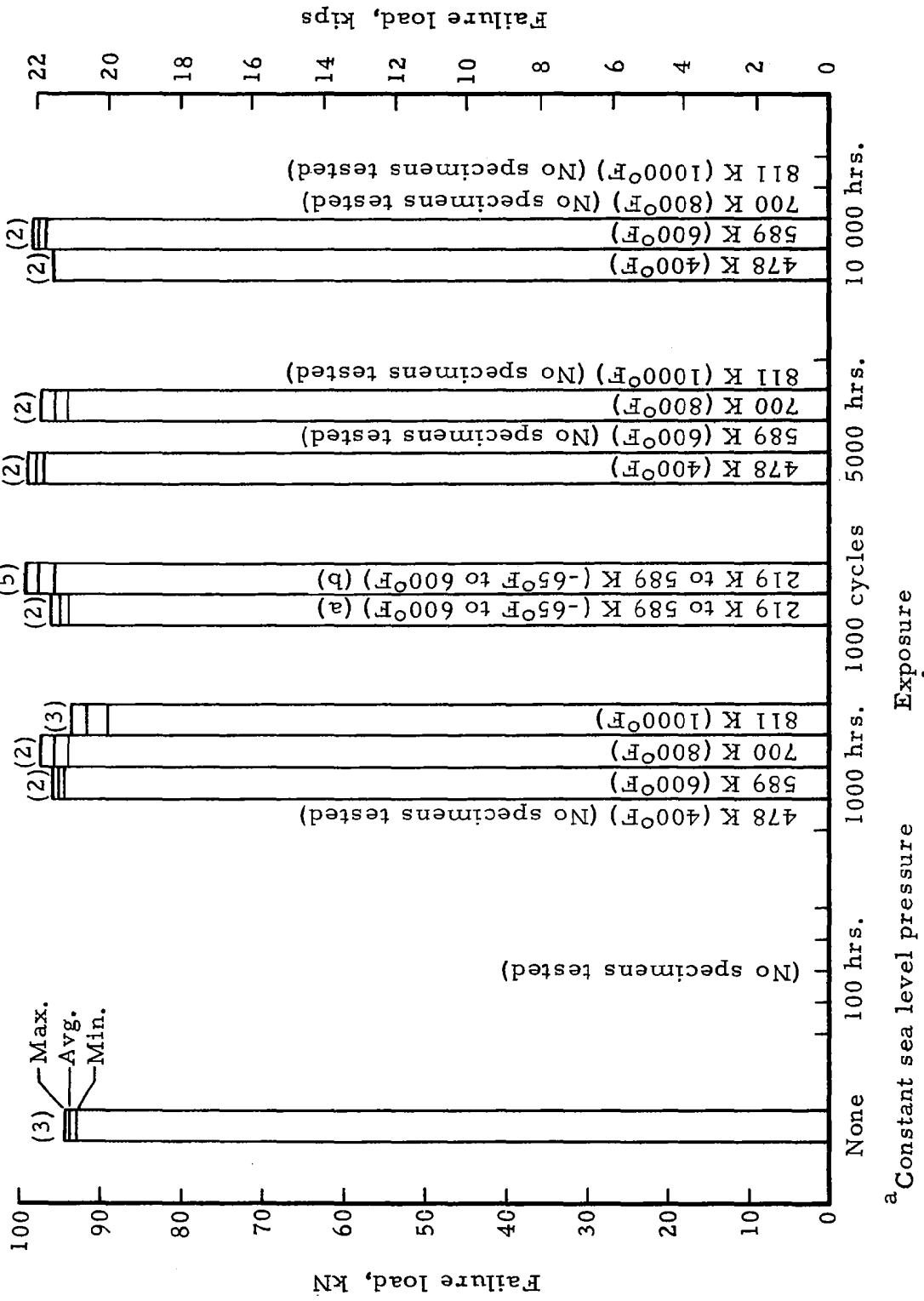

Figure 32. - Strength of weldbraze lap shear specimens.

() - Number of specimens tested



a Constant sea level pressure
 b Varying pressure

Figure 33. - Strength of welded braze compression specimens.

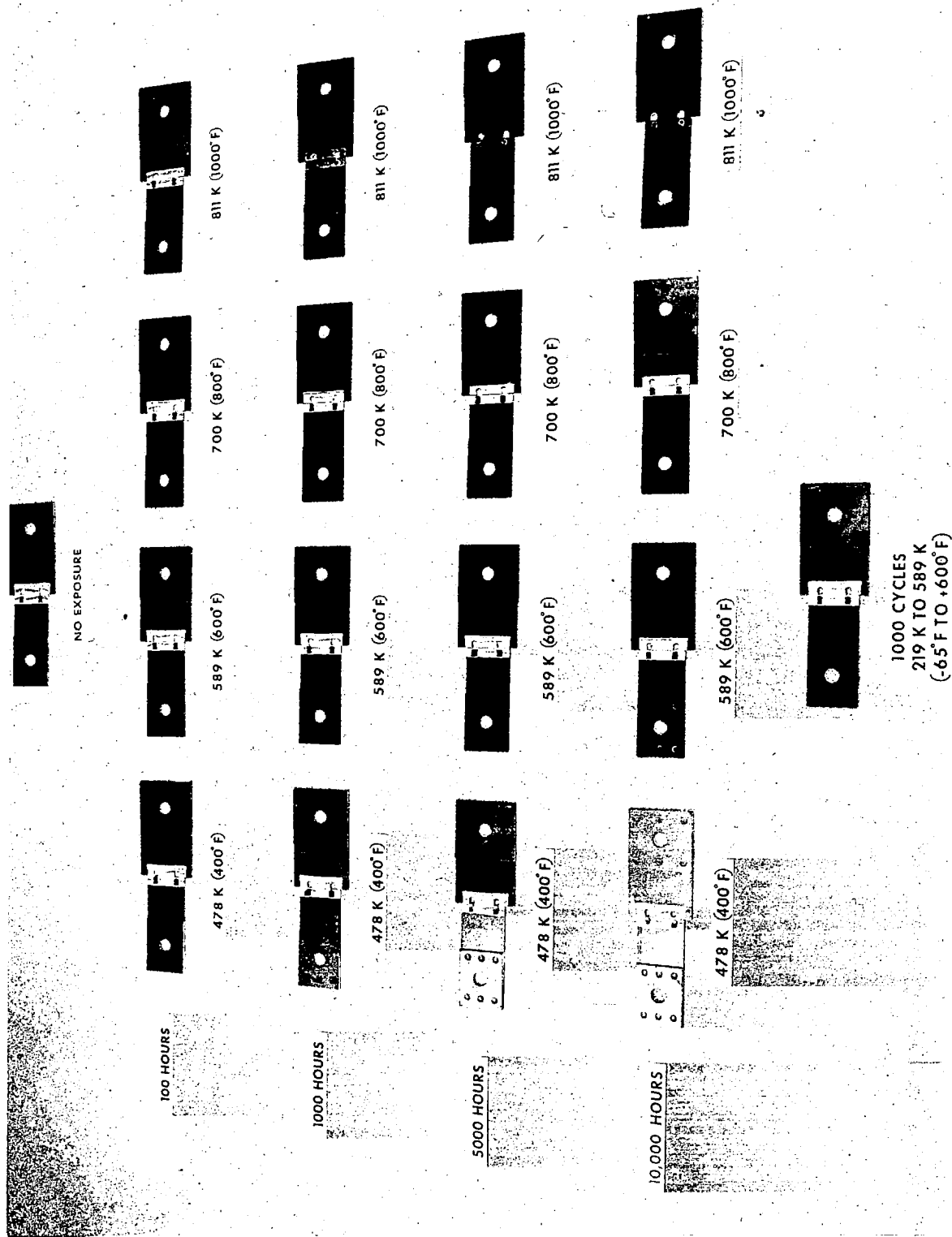

Figure 34. - Typical failures of weldbraze lap shear specimens.

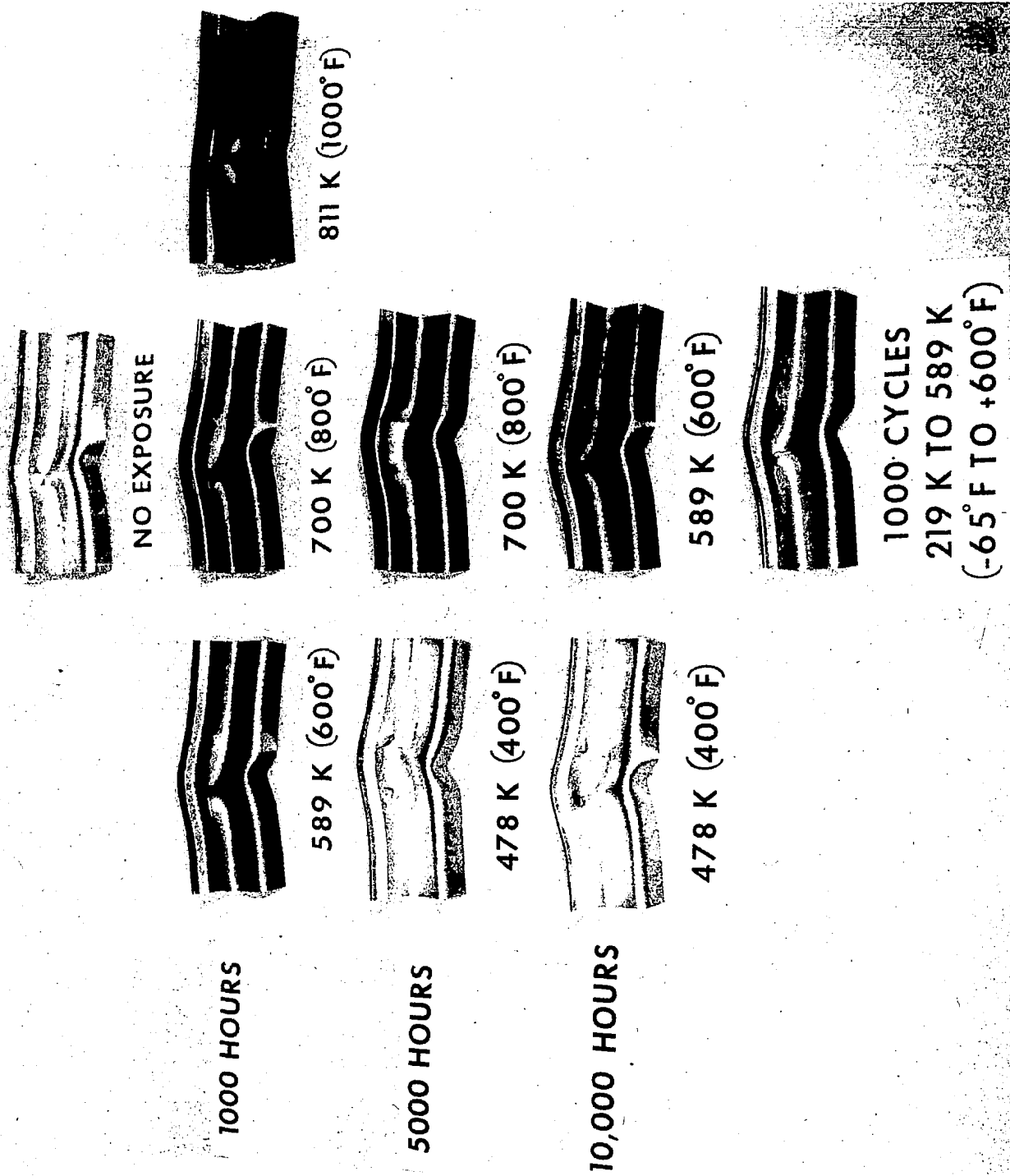

Figure 35. - Typical failures of weldbraze compression specimens.

75-5343-1

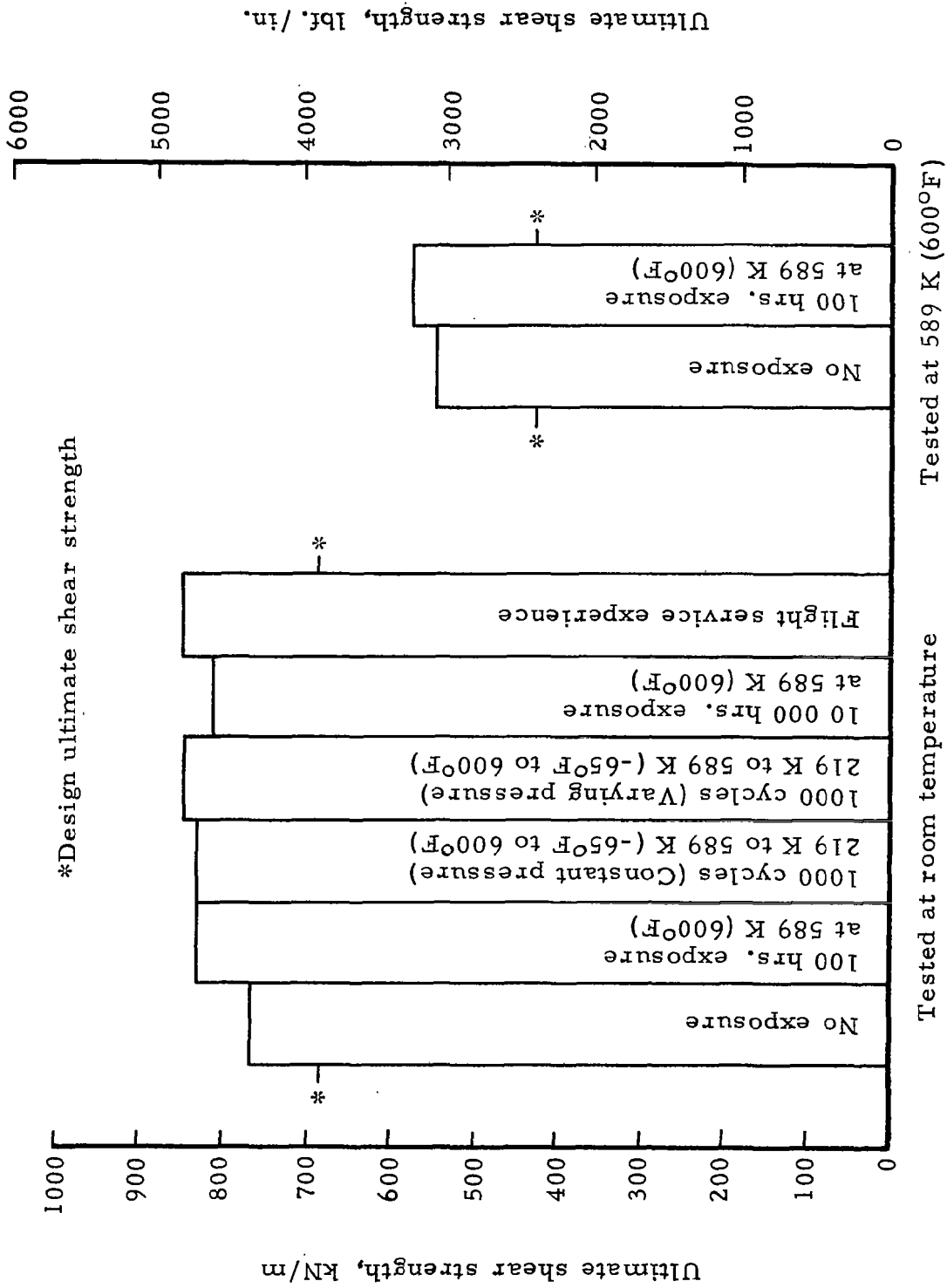
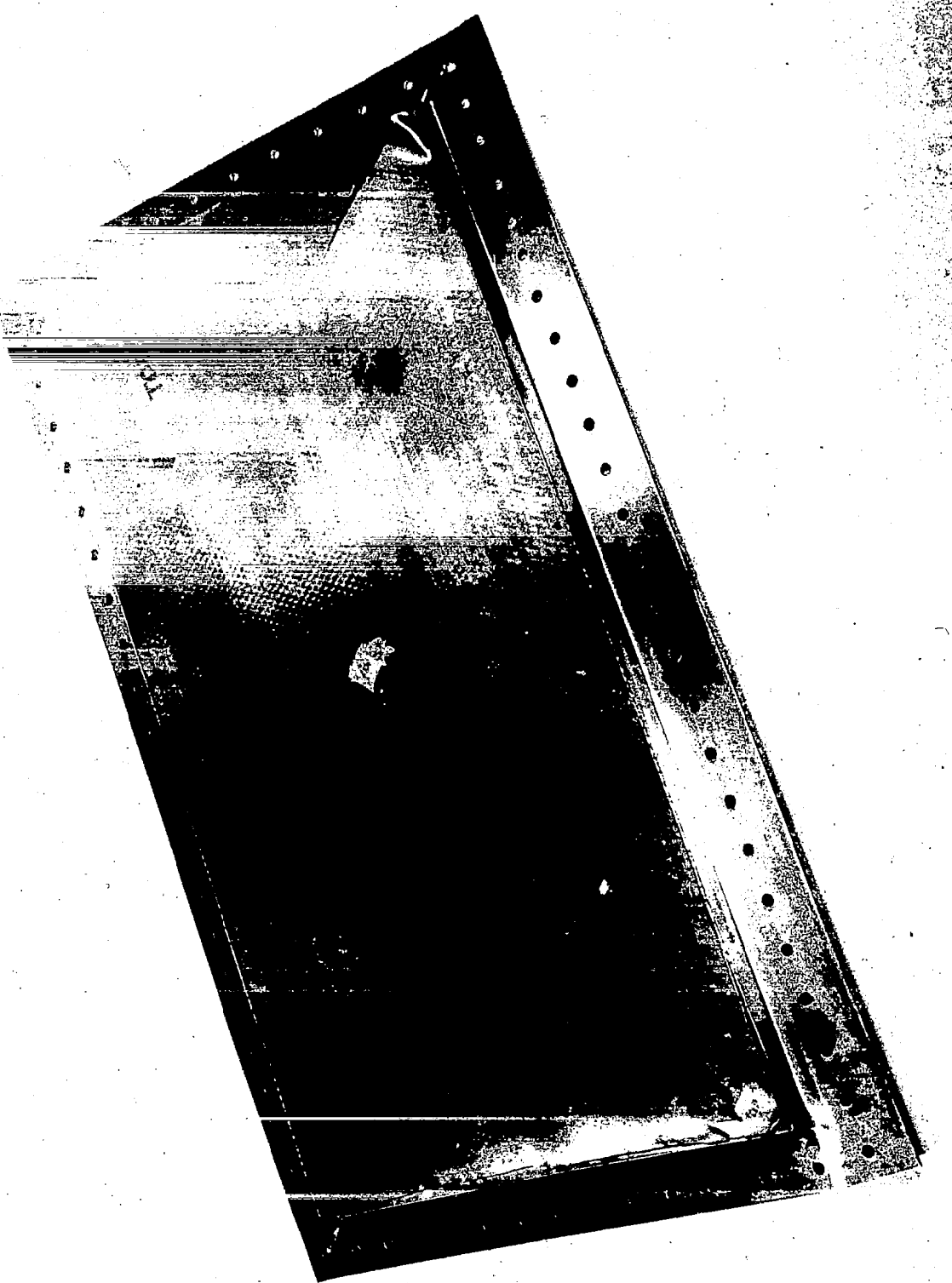

Figure 36. - Shear strength of diffusion bonded panels.



74-5063-2

Figure 37. - Typical failure of diffusion bonded panel tested at room temperature. Interior surface of panel.

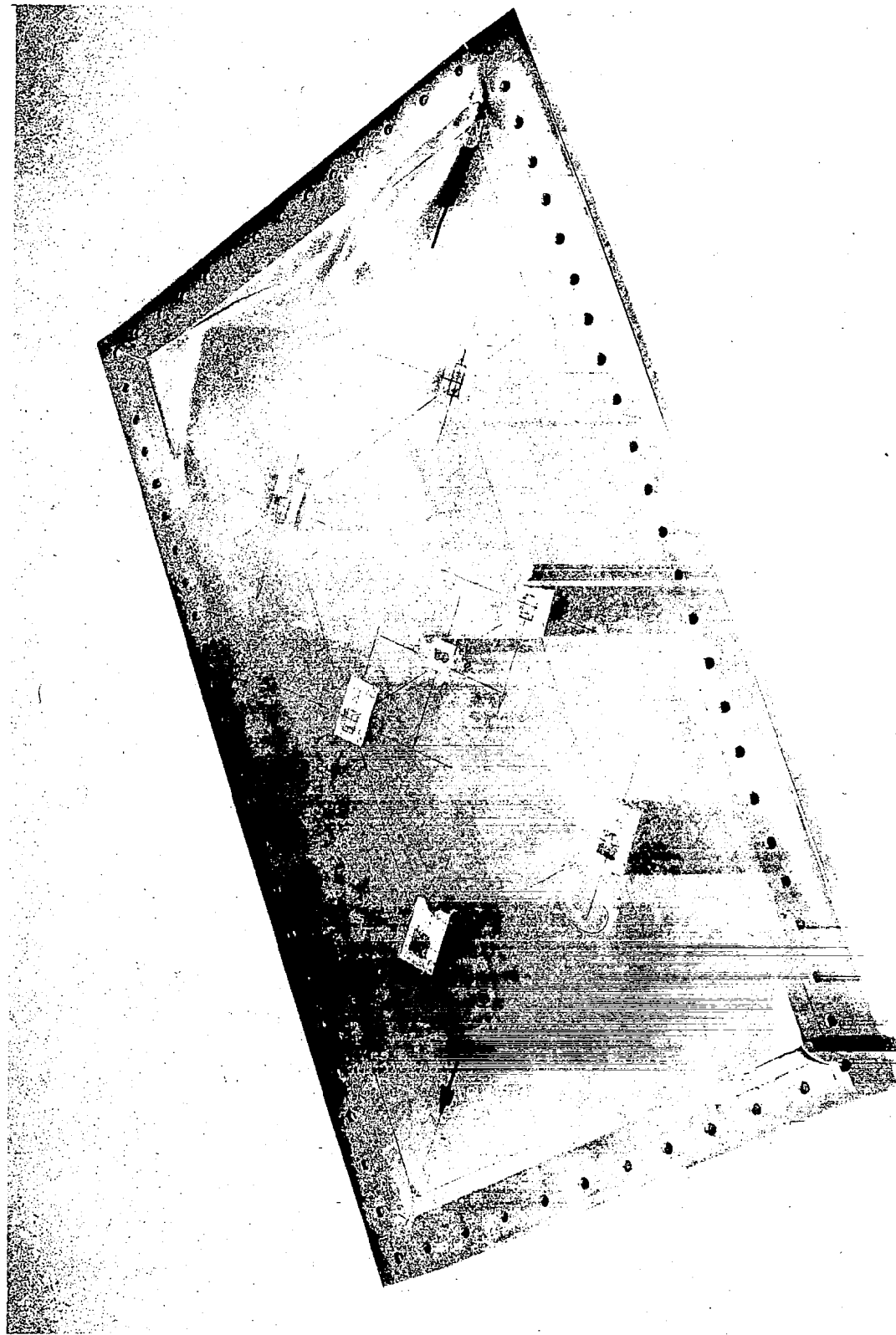
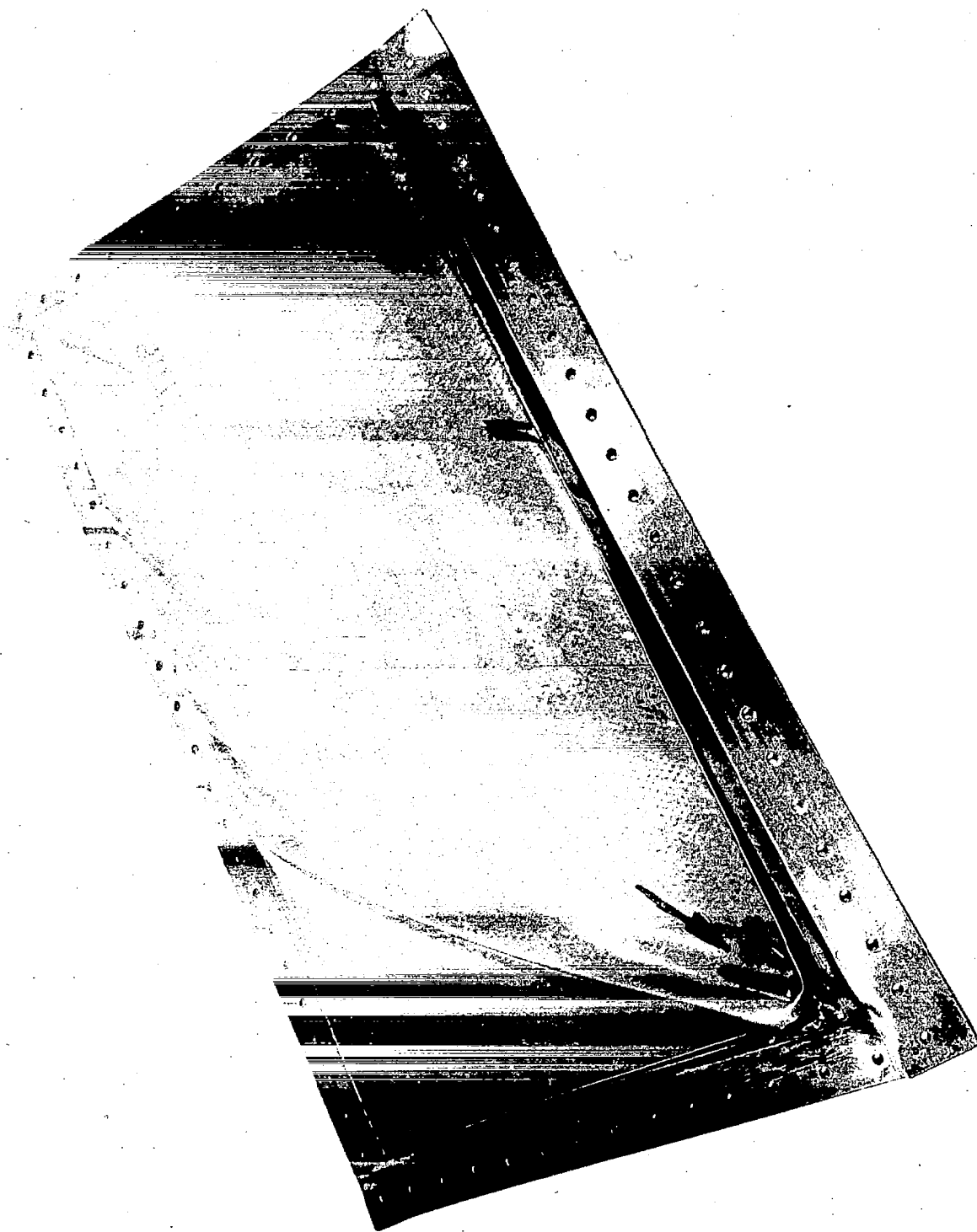

Figure 38. - Typical failure of diffusion bonded panel tested at room temperature. Exterior surface of panel.

74-5063-1



74-5063-6

Figure 39. - Failure of diffusion bonded panel tested at 589 K
(600°F). Interior surface of panel.

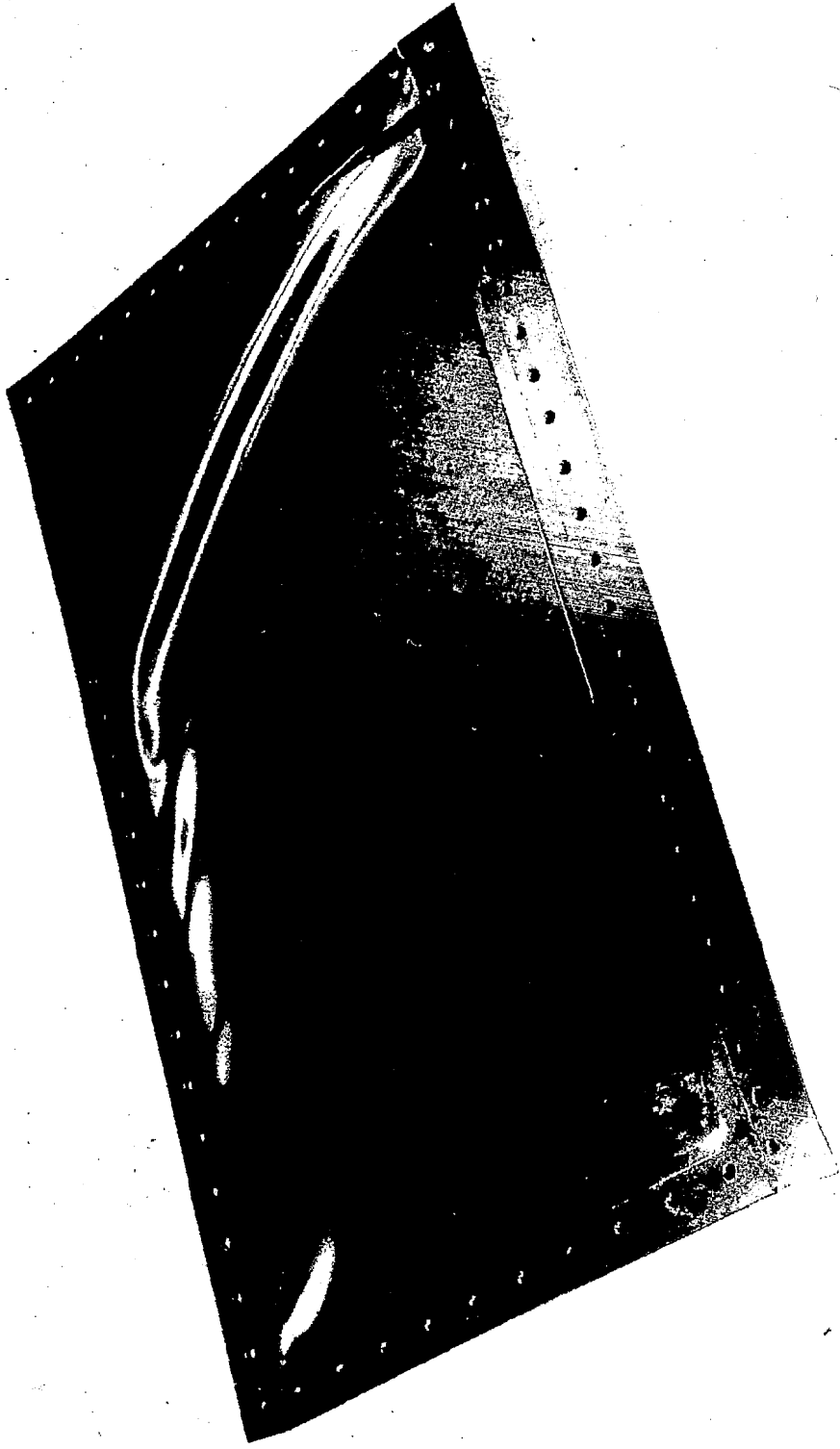
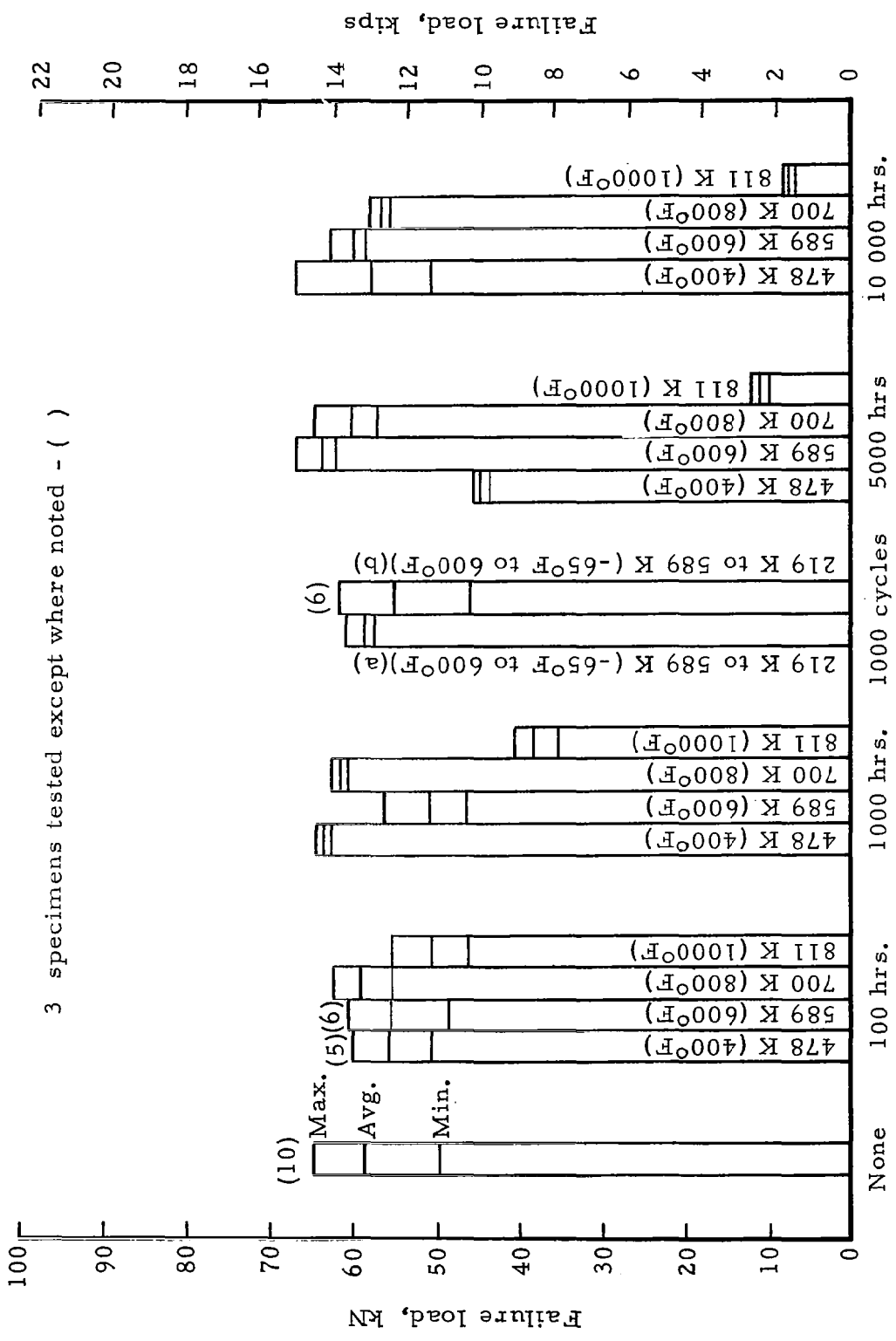

Figure 40. - Failure of diffusion bonded panel tested at 589 K (600°F). Exterior surface of panel.



a Constant sea level pressure

b Varying pressure

Figure 41. - Strength of diffusion bonded flatwise tension specimens.

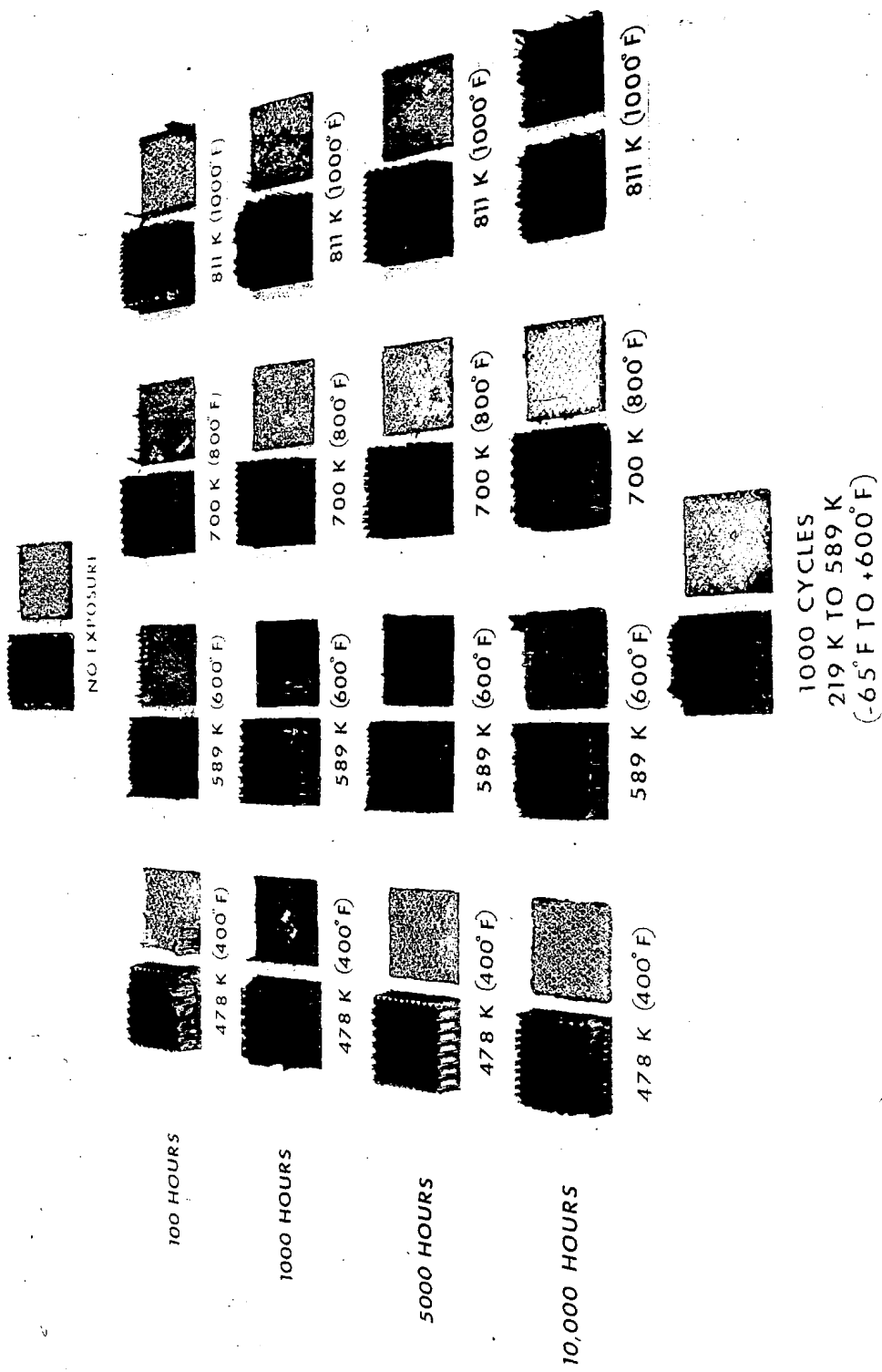

Figure 42. - Typical failures of diffusion bonded flatwise tension specimens.

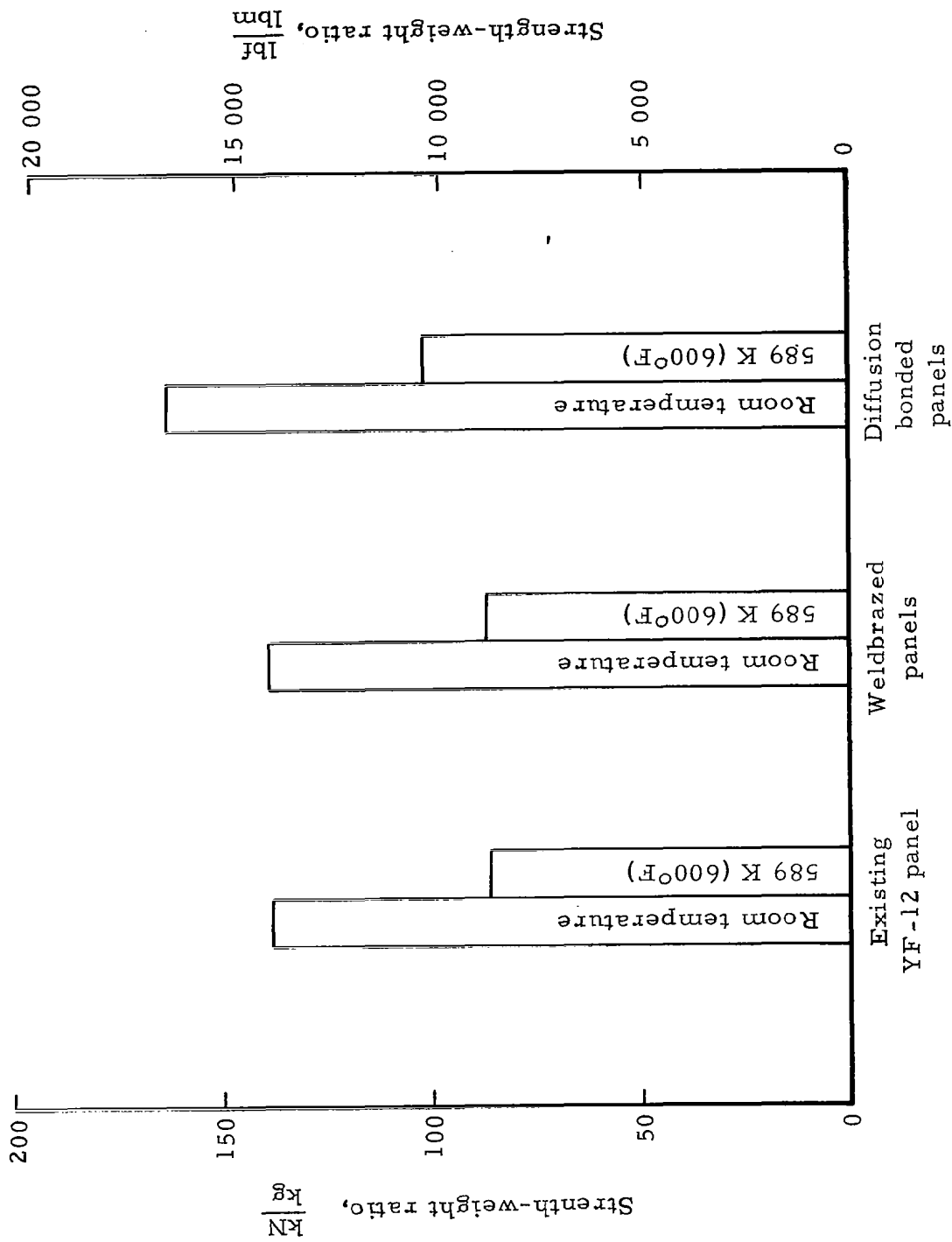

Figure 43. - Relative structural efficiencies of existing YF-12 shear panel, and welded and diffusion bonded panels.

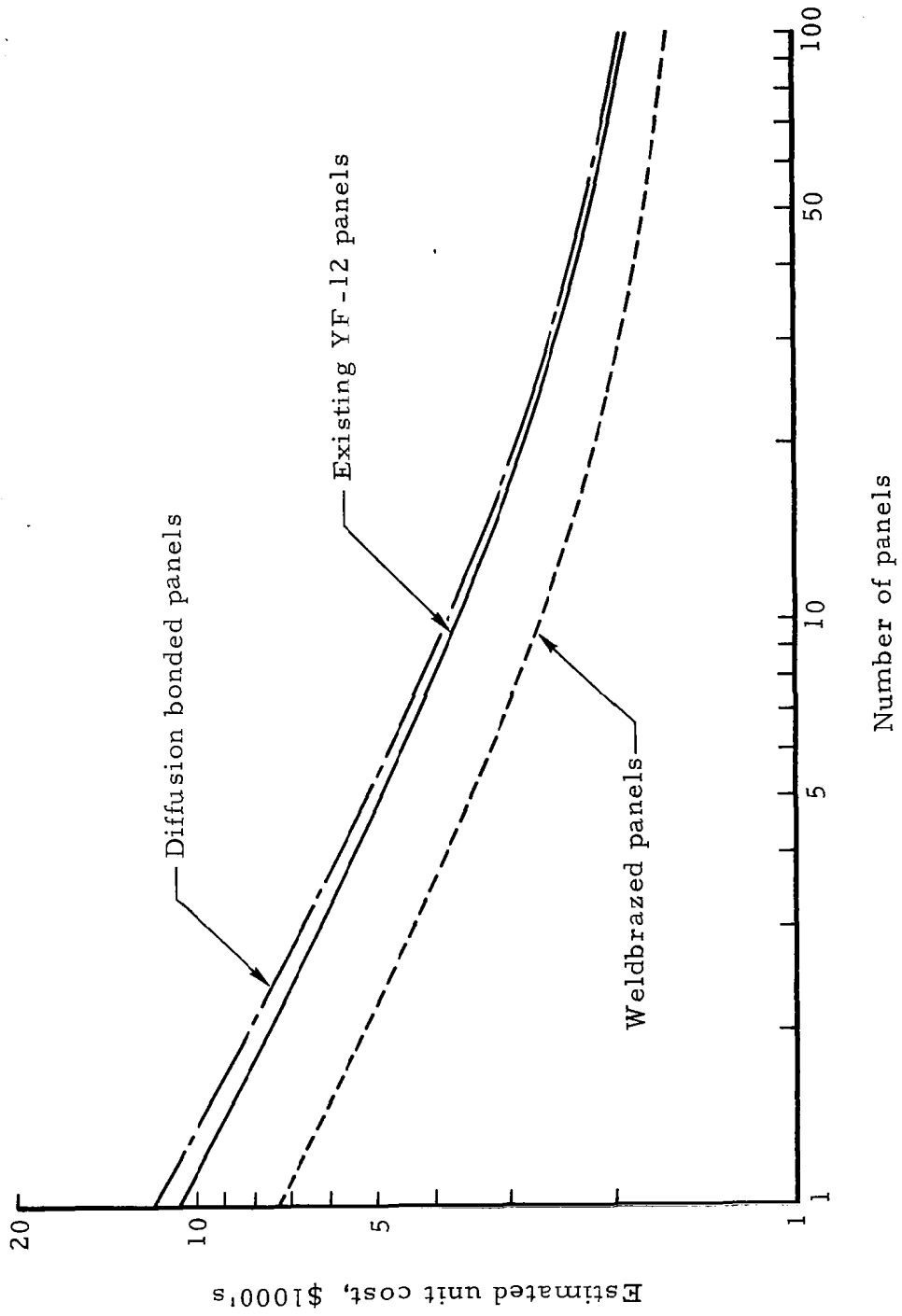

Figure 44. - Relative costs of existing YF-12 shear panel, and weldbrazed and diffusion bonded panels (1975 dollars).