

## Facilitating Human Communications in Personalized Information Spaces

Yasuyuki Sumi   Kazushi Nishimoto   Kenji Mase  
ATR Media Integration & Communications Research Labs.  
Seika-cho, Soraku-gun, Kyoto 619-02, Japan  
{sumi,knishi,mase}@mic.atr.co.jp

### Abstract

There has been an increase in creative activities being done using networked computers, due to the increase in the number of people accessing the Internet. The Internet can be characterized by its global scale, ability of bi-directional communications, and high publicity. Our target is to develop a system that facilitates novel human communications, which has yet to be seen in the real world, with the support of the Internet. We propose a system concept of interactive and asynchronous collaboration and communications in information spaces structured through personal viewpoints of all participants. The method presented in this paper makes possible for a user accessing the WWW (World-Wide Web) to encounter other people who have similar interests. This encounter is definitely different from our daily encounters in the real world, which are mostly limited with personal relationships, and spatial and temporal coincidence. In order to provide a virtual space for the encounters, we employ a method that visualizes personal viewpoints by mapping icons of text-objects and keywords given by users into metric spaces. We are developing a system that visualizes personal viewpoints of contents and opinions appeared in personal pages of the WWW.

**KEYWORDS:** Encounter, Human communications, Asynchronous, Personalization, Viewpoint, World-Wide Web.

### Introduction

We are developing a system that aids in collaborative work and human communications. This paper presents the concepts of the system.

The volume and the range of information available on the Internet continue to expand. From the viewpoint of human communications, the Internet has several attractive features (Murai 1995):

1. It ranges on a world-wide scale.
2. It provides a way of bi-directional communications.
3. Whoever joins in it can play the main role in communications.

The first feature enables users to expand their thought spaces and knowledge on their collaborative fields on a world-wide scale. From the viewpoint of creative thinking, we can say that one of the major processes fostering human creative activities is divergent thinking in which broad alternatives are searched for. Another is convergent thinking in which a unique solution is sought for. Although these two processes must be invoked repeatedly, divergent thinking is indispensable especially at early stages of creative activities. Use of the Internet can broaden one's thought spaces, and encourage divergent thinking. Thus, there have been several works on computer-aided thinking using information on the Internet. For example, (Gaines & Shaw 1995) links a personal hypertext world-wide, and (Kubota & Yamagishi 1995) and (Ohmi *et al.* 1996) have proposed card-based Internet resource accessing tools.

Human communications is basically bi-directional and interactive. However, a lot of the media such as newspapers, radio stations and television networks, provide only a one-way flow of information, i.e. broadcasting. The second and the third features of the Internet are important in this respect. Yet, the conventional usage of the Internet, such as mailing-lists and BBS (Bulletin Board Systems), is broadcasting, and distinguishes providers of information from receivers. Currently, the WWW (World-Wide Web) too only provides one-way flow of information.

The WWW has a strong feature that enables navigation from one personal page to another. People accessing the WWW can find information by following up on the succeeding links made by others. This feature has led to a new kind of search strategy in the context of computer networks – it is an old and familiar way of finding things out in the real world (Erickson 1996). However, there is a definite difference between navigation in the WWW and in the real world, since current information flows in the WWW are limited to one-way. Therefore, no interactions have been occurring between providers and receivers. Consequently, providers of information are unable to get feedback, e.g. 1) who of all receivers has visited or given links

to their pages in the receivers' contexts, 2) what these contexts are, and 3) how is the information being provided contributing toward new information. Besides, when providers create new pages on the WWW and wish to communicate with other people on the Internet through these pages, they must announce the openings through other broadcasting media such as a BBS.

When we regard the Internet as a world-wide knowledge-base, the KB consists of pages of contents and hyper-links in case of the WWW. As the contents are produced independently and the hyper-links are established sequentially, the net has characteristics of the distributiveness and the asynchronism of knowledge, which are also the important advantages. Under this consideration, in order to make the best use of these advantages for personal and collaborative work, we should utilize the Internet not only as a medium for broadcasting but also as a space where we can convey personal information to others interactively, i.e. the interaction of provider and receiver.

We are developing a system that encourages a novel type of communications, one that has not been seen in the real world, with the advantages of the Internet. In this paper, we propose the concept of *encounters in a networked society from third persons' personalized views*. The proposed method makes possible for a user accessing the WWW to encounter other people who have similar interests. For a virtual place where they can encounter, this method appropriates a third person's home page, which has several reference links to other pages including the user's. Such encounter is definitely different from that in the real world in the following features:

- encounters are not restricted by spatial and temporal coincidence.
- encounters are made not by personal relationships, but by the *relevance of personal interests*.

In order to provide a virtual space for the encounters, we employ a method that visualizes personal viewpoints by mapping icons of text-objects and keywords given by users into metric spaces (Sumi *et al.* 1996). We are developing a system that visualizes personal viewpoints of contents and opinions appeared in personal pages of the WWW.

### Encouraging new personal encounters in a networked society

This paper describes a system that facilitates new personal encounters in a virtual society emerged from networked computers. Now, we point out our target in a classification of communication support systems on networked computers from three viewpoints on the types of processed information (see Figure 1).

#### synchronous meeting → asynchronous meeting

Our research focuses on collaborations not limited with spatial and temporal synchronization.

**shared spaces → personalized spaces** Most existing systems that aid in collaborative work on networked computers focus on providing common and shared spaces to participants. Our interests shift to supporting the personalization of shared spaces for individual reflections and collaboration in personalized information spaces.

**one-way flow → two-way flow** Most existing systems strictly distinguish the providers and receivers of information, and deal only with one-way flow of information. We are interested in the bi-directional and interactive flow of information. That is, some actions of the receivers such as gathering information and editing are given as feedback to the providers.

The authors' group has proposed the concept of the MetaMuseum (Kadobayashi & Mase 1995), which is a new environment for knowledge sharing. The primary goal of the MetaMuseum is to create and facilitate communications between specialists (providers of information and knowledge) and visitors (receivers of them) thereby enabling a better understanding of museum exhibitions. The MetaMuseum is one of the systems pointed out above.

## Visualizing structured information spaces

### CSS: Communication Support System

In this research, our approach is to visualize information spaces for collaborative work and communications on the Internet including new encounters between people accessing the Internet. This section describes our existing system which visualizes personalized spaces as well as shared spaces.

The authors have proposed several computer tools (*AAI* (Hori 1994), *CATI* (Sumi, Hori, & Ohsuga 1992), *CSS* (Sumi *et al.* 1996), etc.) to aid in creative concept formation by visualizing snapshots of the topological structures of a user's thought space<sup>1</sup> using statistical methods. Here, we present one of these, *CSS*, which stands for Communication Support System. *CSS* has been used for individual reflection and shared understanding in groups working collaboratively. *CSS* works successfully on visualizing the global structure of a user's thought space. These visualizations encourage the user to further his/her thinking, such as finding the axes of a semantic structure in the presented space, or finding new ideas in empty regions in the presented space. *CSS* also has the potential to show a user's subjective ideas and views to his/her colleagues (Sumi *et al.* 1996).

Figure 2 is an example of using *CSS* for individual reflection in arranging research memos written by one of the authors. *CSS* is implemented under the X

<sup>1</sup>Here, we define the *thought space* as an externalized mental space consisting of fragments of ideas or knowledge and the relationships among them in thinking activities.

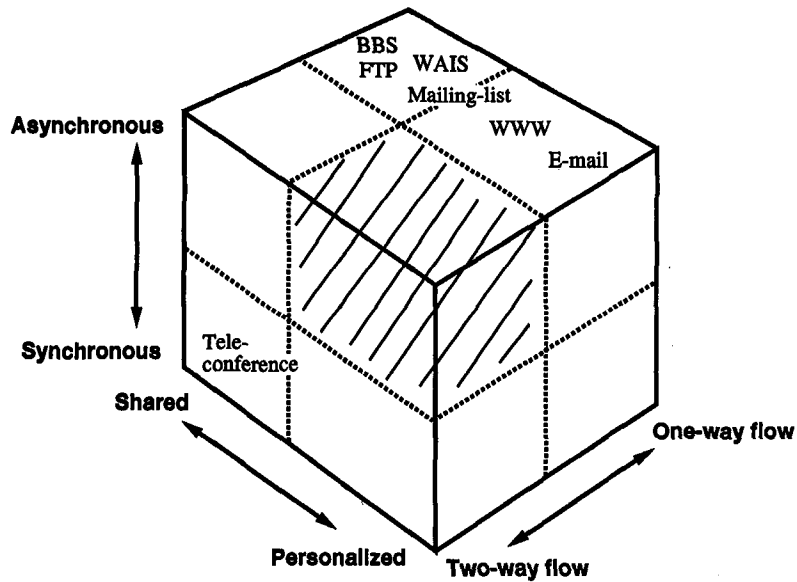

Figure 1: Classification of communication support systems on networked computers. Facilitating communications in the hatched region of this classification is our target.

list of text-objects which declare a keyword 'association'

Association KeyWords Table

association	(ok) (cancel)
Management of files	5.0
Information society	5.0
Problems with existing systems	4.0

Model of thinking process

Model of thinking process	(ok) (cancel)
abstract	2.0
people	5.0
nodal	4.0
process	3.0
research	2.0
thinking	2.0
object	1.0

list of keywords declared in a text-object 'Model of thinking process'

text-object

keyword

content of a text-object 'Computer aided thinking'

Figure 2: Example of using CSS for personal concept formation.

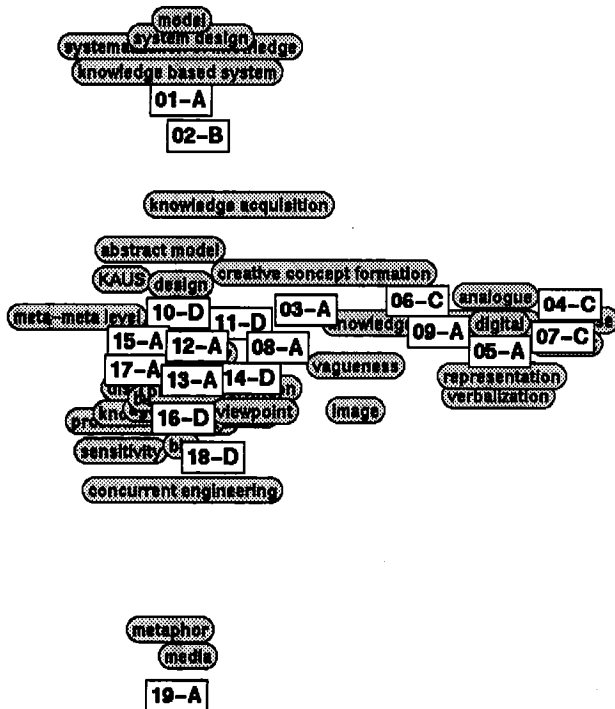

Figure 3: Snapshot of a semantic structure of an on-line discussion.

Window System on a UNIX workstation, and offers a user interface with multiple windows. *CSS* manages a data table which contains text-objects, keywords, and weight values given by users to text-object and keyword pairs. Designating keywords and their weight values to text-objects are done by users according to their subjectivity. The users reflect their thoughts to change the data set. Whenever the users instruct *CSS* to reconfigure the space, it calculates and shows a new configuration according to the current data.

*CSS* is not limited to use by an individual user. That is, *CSS* can provide a shared space for groups of people, where text-objects may be given by multiple users. Figure 3 shows an example of using *CSS* to visualize a snapshot of a group discussion on an on-line news system. In this group discussion, four people join to discuss "a knowledge-based system for design" which is not an articulated idea yet. The rectangular icons are text-objects, which show statements posted via on-line news systems<sup>2</sup>. The oval icons are keywords which are verbalized by the participants. The space which is presented by *CSS* visualizes relationships among the participants, topics, and their keywords. This visual information is useful for the participants, allowing them to realize their positions as well as for outsiders to grasp an overview of the discussion.

<sup>2</sup>"12-A" indicates that this statement is posted 12th by a participant A, for example.

We have had another trial of visualizing relationships among micro-concepts which compose each personal thought space, by merging the thought spaces of multiple users on *CSS* with a common set of text-objects, corresponding to common topics given (Sumi *et al.* 1996). With this trial, differences are revealed between the users' thought spaces reflected by their viewpoints or backgrounds, and the users are spared from communication gaps due to unconscious differences in personal knowledge or viewpoints (see Figure 4). We employ a simple method that constructs a new data table of keywords and text-objects by mixing together several personal data sets extracted independently from each user. This method distinguishes between a keyword given by a certain user and one given by another even if those keywords coincidentally have the same expression. This enables, for example, users to contrast one individual's use of "media" with another's "media" in a merged space presented by *CSS*.

### Linking *CSS* to the World-Wide Web

*CSS* successfully works in visualizing personalized information spaces and collaborative shared spaces. We are now connecting *CSS* to other technologies in order to deal with world-extended collaboration and human communications on the Internet.

Personal pages being created on the WWW are blending the professional and the personal. At the same time, these personal pages have good accessibility and publicity for people accessing the Internet.

Some pages are designed as a meta page which collects many pages and classifies them in some context, which are useful for many people. Some are very huge collections for common use, and some are personal collections due to the collectors' subjectivity. The latter may be nonsense for most others, but it may offer some ideas or viewpoints to people who have similar interests.

The objective of *CSS* is to reveal personal ideas and viewpoints, and thereby encourage collaboration and communications in groups of people. Currently, *CSS* mainly uses documents given by users themselves, and this information is used for collaboration only in groups explicitly organized. However, on the current Internet, there are many electronic documents, and so asynchronous collaboration can also be expected with people who are not yet acquainted. Therefore, porting *CSS* to enable it to integrate seamlessly with the WWW is a straightforward expansion strategy.

Currently, we are linking *CSS* to other knowledge elicitation technologies (AlHaj, Sumita, & Iida 1995), (Nishimoto *et al.* 1995), which have large external knowledge-bases (built statically, however). Regarding the WWW as a dynamically self-organized knowledge-base, the employment of existing (primitive) search engines on the WWW (e.g. Yahoo<sup>3</sup>,

<sup>3</sup><http://www.yahoo.com/>

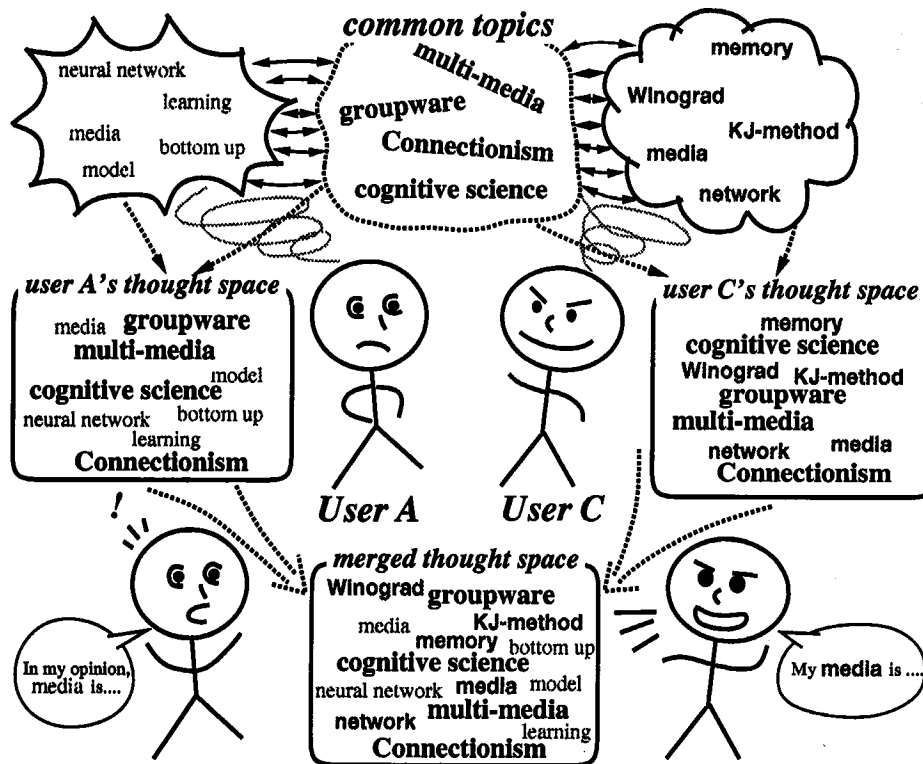

Figure 4: Merging multiple users' personalized spaces.

Infoseek<sup>4</sup>) seems appropriate.

### Asynchronous encounters from third persons' personalized views

This section describes the idea of asynchronous encounters from third persons' personalized views, which gives users the chance to make acquaintances based on their interests.

As places for possible encounters, we employ personal pages on the WWW having several links to other people's pages that are relative to each other in some context. These personal pages have the potential to provide effective stimuli to people whose pages are referred to by them.

However, on the current WWW, users whose pages are referred to by other persons' pages are unable to know who make these links. If they could notice that a third person's page is referring to their page, they could get to know people who have a similar relationship from the third person's viewpoint. These encounters would definitely be of a different type than existing communications in the real world, in the sense that they could not meet with these people unless there were personal connections.

There are two choices to make them notice the possible connections.

1. A person who edits a page having several links to other pages could contact and report these links to those who provide these pages. Otherwise, some software agent could automatically inform providers of the fact that a certain page is referring to their pages.
2. Users who are keen for new encounters with people having similar interests could take action by themselves. This would necessitate some technologies that search for pages referring to their personal pages by pursuing links with opposite directions.

Currently, we think that the first strategy is interfering to general users. Therefore, this paper selects the second strategy. In order to achieve this approach, we propose using existing search engines to search for opposite links (e.g. Senrigan ("clairvoyance" in Japanese)<sup>5</sup>, RCAAU<sup>6</sup>). These search engines collect information on links on the WWW comprehensively to gather information about pages that will be queried by users. Here, we utilize information on links to search pages linking the same page.

<sup>4</sup><http://www.infoseek.com/>

<sup>5</sup><http://www.info.waseda.ac.jp/search.html>

<sup>6</sup><http://www.kuamp.kyoto-u.ac.jp/labs/infocom/mondou/>

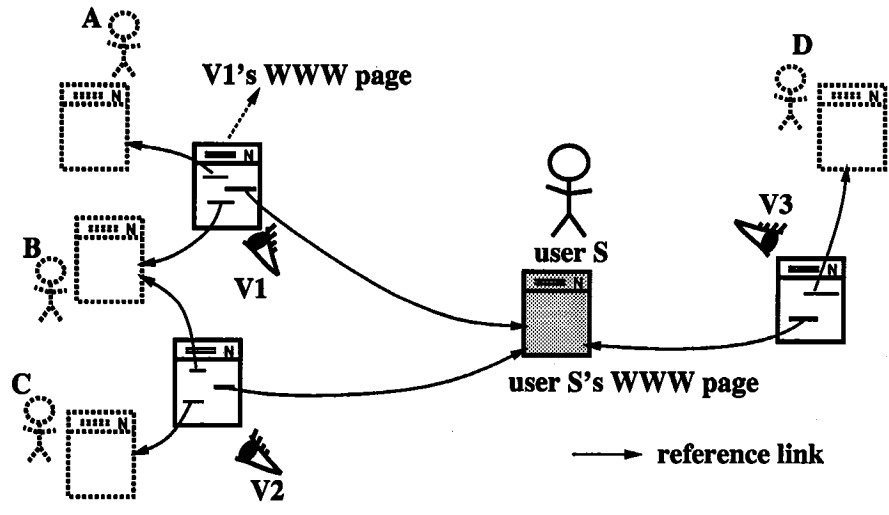

(a) A web of reference links on the WWW.

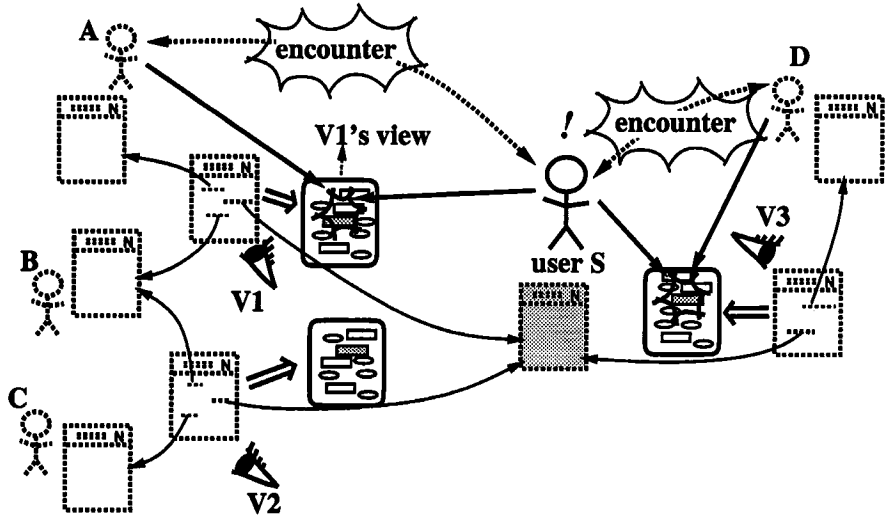

(b) Personal views of third persons cause encounters between user S and other people on the WWW.

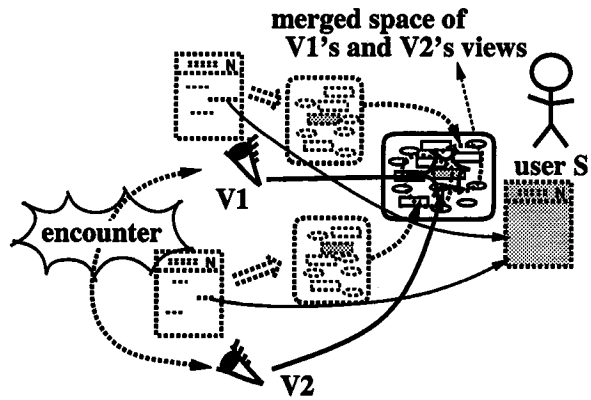

(c) The action of user S causes encounter between V1 and V2.

Figure 5: Emergent encounters on the WWW caused by third persons' views.

Below is a procedure for encounter in a third person's page on the WWW (see Figure 5).

1. User S takes action to get to know people on the WWW who have similar interests.
2. The system generates a list of pages referring to user S's page by searching a database consisting of information on links. In Figure 5(a), V1's, V2's, and V3's pages have links referring to user S's page.
3. The system provides places to facilitate encounters by visualizing each creator's view along with his/her page's contents consisting of information on links. Here, we expect that CSS is suitable as a virtual space for the encounters.
4. User S gets to know several people beyond the network by looking at visualized spaces. In Figure 5(b), user S encounters users A and B in V1's view.
5. Merging multiple spaces representing personal views with CSS encourages other encounters between people referring to user S's page. That is, user S's action enables encounters between people who have an interest in user S's personal page. In Figure 5(c), V1 and V2 encounter in V1's and V2's merged space. This encounter enables them, who are not yet acquainted, to get to know the relevance between their viewpoints.

## Conclusion

We have proposed a notion of computer-aided communications in a networked society emerged on the Internet. In this paper, we described a concept of a system supporting interactive and asynchronous collaboration and communications in information spaces structured with personal viewpoints. We proposed a novel type of encounter between people accessing the WWW by utilizing third persons' home pages consisting of several links to other home pages.

We presented a system, called CSS, that supports individual reflection and collaborative concept formation by visualizing the thought spaces of users. We are connecting CSS to the WWW in order to facilitate worldwide asynchronous collaboration. Currently, users of CSS must designate text-objects, their keywords, and weight values. In order to utilize CSS for facilitating collaboration and communications on the WWW, automation of these tasks is essential. Employment of existing search engines with statistical methods is under consideration.

## Acknowledgment

The authors thank Kohei Habara and Ryohei Nakatsu for their support and encouragement throughout this work. The authors also thank members of ATR MI&C for their valuable discussions.

## References

- AlHaj, A. M.; Sumita, E.; and Iida, H. 1995. Text retrieval using parallel computers. In Geller, J.; Kitano, H.; and Suttner, C., eds., *Workshop on Parallel Processing for Artificial Intelligence (IJCAI 95)*.
- Erickson, T. 1996. The World-Wide Web as social hypertext. *Communications of the ACM* 39(1):15-17.
- Gaines, B. R., and Shaw, M. L. G. 1995. Concept maps as hypermedia components. *Int. J. Human-Computer Studies* 43(3):323-361.
- Hori, K. 1994. A system for aiding creative concept formation. *IEEE Transactions on Systems, Man, and Cybernetics* 24(6):882-894.
- Kadobayashi, R., and Mase, K. 1995. MetaMuseum as a new communication environment. In *Multimedia Communication and Distributed Processing System Workshop*, 71-78. Information Processing Society of Japan. in Japanese.
- Kubota, A., and Yamagishi, T. 1995. A tool for aiding knowledge emergence by utilizing Internet space. In *Proc. annual conf. Japanese society for Artificial Intelligence*, 275-278. in Japanese.
- Murai, J. 1995. *Internet*. Iwanami Shinsho. in Japanese.
- Nishimoto, K.; Abe, S.; Miyasato, T.; and Kishino, F. 1995. A system supporting the human divergent thinking process by provision of relevant and heterogeneous pieces of information based on an outsider model. In *Proc. IEA/AIE-95*, 575-584.
- Ohmi, Y.; Nakamura, K.; Kawai, K.; Takeda, N.; and Ohiwa, H. 1996. PAN-WWW: A card-based Internet resource accessing tool. *Trans. of Information Processing Society of Japan* 37(1):154-162. in Japanese.
- Sumi, Y.; Mase, K.; Ogawa, R.; Hori, K.; and Ohsuga, S. 1996. Facilitation of collaborative concept formation by visualizing thought space structure. Technical report, TR-M-0005, ATR Media Integration & Communications Research Labs.
- Sumi, Y.; Hori, K.; and Ohsuga, S. 1992. Computer-aided thinking based on mapping text-objects into metric spaces. In *The 2nd Pacific Rim International Conference on Artificial Intelligence*, 183-189.