

UNITED STATES
DEPARTMENT OF THE INTERIOR
GEOLOGICAL SURVEY

345 Middlefield Road
Menlo Park, CA 94025

FACTORS LIMITING THE SENSITIVITY AND DYNAMIC RANGE OF A SEISMIC
SYSTEM EMPLOYING ANALOG MAGNETIC TAPE RECORDING AND A SEISMIC
AMPLIFIER WITH ADJUSTABLE GAIN SETTINGS
AND SEVERAL OUTPUT LEVELS

by

J. P. Eaton and J. R. Van Schaack

Open-File Report 77-224

April 1977

This report is preliminary and has not been edited or reviewed for conformity with Geological Survey standards and nomenclature.

Any use of trade names and trademarks in this publication is for descriptive purposes only and does not constitute endorsement by the U.S. Geological Survey.

FACTORS LIMITING THE SENSITIVITY AND DYNAMIC RANGE OF A SEISMIC SYSTEM EMPLOYING
ANALOG MAGNETIC TAPE RECORDING AND A SEISMIC AMPLIFIER WITH ADJUSTABLE GAIN SETTINGS
AND SEVERAL OUTPUT LEVELS

J. P. Eaton and J. R. Van Schaack

I. INTRODUCTION

In the course of modernizing the low-speed-tape-recorder portable seismic systems and considering the possibilities for the design of a cassette-tape-recorder seismic refraction system, the factors that limit the sensitivity and dynamic range of such systems have been reviewed. These factors will first be stated briefly, and then their influence on systems such as the new 5-day-tape seismic system will be examined in more detail. To fix ideas, we shall assume that the system consists of the following elements:

1. A seismic sensor: usually a moving coil inertial seismometer with a period of about 1 second, a coil resistance of about 5000 ohms, and an effective motor constant of 1.0 V/cm/sec (across a 10K load terminating the seismometer sensitivity-and-damping-adjustment resistive network).
2. A seismic amplifier/voltage controlled oscillator unit made up of the following components:
 - a) A fixed gain preamplifier with an input resistance of 10K and an internal noise level of $0.5 \mu\text{Vpp}$ referred to the preamp input ($0.1 \text{ hz} \leq \text{freq.} \leq 30 \text{ hz}$).
 - b) An adjustable gain (0 to 42 db in 6 db steps) intermediate amplifier.

- c) One or more fixed gain output amplifiers.
 - d) Two sections of 6 db/octave bandpass filter serving to couple the 3 amplifier stages together.
 - e) Voltage controlled oscillators for each output amplifier to produce modulated FM carriers for recording on separate tape tracks or modulated FM subcarriers for subsequent multiplexing and direct recording on tape in the California Network format.
3. An analog magnetic tape recorder: e.g. the PI 5100 (15/80 ips recording in the FM mode or in the direct mode with the "broad-band" variant of the Cal Net multiplex system, or 15/16 ips recording in the direct mode with the standard Cal Net multiplex system), or the Sony TC-126 cassette recorder operating in the direct record mode with the standard Cal Net multiplex system.
 4. Appropriate magnetic tape playback equipment: e.g., the Bell and Howell 3700-B for the PI-5100 or the Sony TC 126 for its own tapes.
 5. Appropriate discriminators (employing subtractive compensation, at least for the multiplexed systems) to restore the data signals to their original forms.
 6. An A/D convertor to digitize the seismic signals for computer processing and/or a strip chart recorder (e.g., the Siemens Oscillomink) for playout of the data.

II. FUNDAMENTAL LIMITS OF THE AMPLIFIER AND TAPE RECORDER

The ultimate limit on sensitivity of the overall seismic system is the input noise level of the seismic preamplifier: the internal noise of the preamplifier (referred to its input) must be less than the signal supplied by the seismometer to the preamp input if that signal is to be detectable. The ultimate limit on the dynamic range of the overall system is also set by the preamp: that limit is simply the ratio of the maximum preamp output level to the preamp internal noise level measured at the preamp output. Thus, if the maximum preamp output is 8.0Vpp,

if its gain is 18 db, and if its internal noise is 0.5 μ Vpp (input) or 4.0 μ Vpp (output), the dynamic range of the preamp (and the maximum dynamic range of the overall system) is $8.0/4.0 \times 10^{-6}$, or 126 db.

The practical limit on dynamic range of a single channel (or single output level of a multilevel seismic amplifier) is set by the tape record/tape playback portion of the system (modulators, multiplexer, tape recording machine, tape reproducing machine, discriminators). Tests with the modulators, multiplexer, and discriminators coupled directly together, without the tape recorder, shows that these elements of the Cal Net system have a dynamic range of about 60 db. When tape recording and playback is also included the dynamic range is substantially reduced, primarily because of tape speed variations in the record and playback machines. With most machines used by NCER, effective use of tape speed compensation (particularly subtractive compensation) is indispensable for attaining acceptable dynamic range levels. A brief summary of results obtained with various styles of recording on NCER tape recorders is as follows:

Dynamic Range

<u>Recording</u>		<u>Playback</u>		<u>Format</u>	<u>Dynamic Range</u>	
<u>Machine</u>	<u>Tape Speed</u>	<u>Machine</u>	<u>Tape Speed</u>		<u>With</u>	<u>Without</u>
					<u>TSC</u>	<u>TSC</u>
B & H 3700	15/16 ips	B & H 3700	15/16 ips	(1)	48-50db	34-46db
PI 5100	15/16 ips	B & H 3700	15/16 ips	(1)	46-48db	24-36db
PI 5100	15/80 ips	B & H 3700	15/16 ips	(2 ¹)	36(4ch)-40(3ch)db	15-30db
PI 5100	15/80 ips	B & H 3700	15/16 ips	(3)	42db?	36db
Sony TC-126	1 7/8	Sony TC-126	1 7/8	(1)	46-48db	24-36db
Sony TC-126	"	Sony TC-126	"	(2)	36(4ch)-40(3ch)db	15-30db

Format (1) Standard NCER seismic data multiplex system: 8 data channels (0.1 hz - 30 hz), 2 timing channels (0 hz - 100 hz), 1 compensation channel.

Format (2) Broad-band variant of NCER seismic data multiplex system: 4 data channels (0.1 to 150 hz), 1 compensation channel.

Format (2¹) Hybrid form of (2): 4 data channels (0.1 hz - 30 hz), 1 compensation channel. Recorded at 15/80 ips and played back at 15/16 ips.

Format (3) 1 FM data channel (0.1 hz to 30 hz) recorded at 15/80 ips and played back at 15/16 ips. "Record" center frequency and modulation: 338 hz \pm 135 hz.

Thus, the dynamic range of a single magnetic tape data channel depends strongly on data bandwidth, tape recorder speed, mode of recording (FM with 1 data channel per tape track, or direct recording of a multiplexed FM subcarrier system with several data channels per tape track), and effectiveness of tape speed compensation. For the PI 5100 operating at 15/80 ips in format 3 or in format 2¹ a dynamic range of about 40 db can be attained. For the PI 5100 operating at 15/16 ips, or the Sony TC-126 operating at 1 7/8 ips, with the standard NCER seismic data multiplex system (format 1), a dynamic range of 46 to 48 db can be attained.

The effective dynamic range of a seismic system can be increased above that attainable from a single tape data channel by using several output amplifiers with different gain levels to record the same seismic signal at different modulation levels on separate tape data channels. However, a relatively large "overlap" between adjacent levels is required to insure an acceptable signal to noise ratio on the next lower level channel as a given channel reaches the clipping level. To preserve a minimum signal to noise ratio of 8 to 1 (18 db), the separation between adjacent levels should not exceed 24 db in a system with a single tape data channel dynamic range of 42 db. The effective dynamic range of a multilevel system is the single tape data channel dynamic range plus the separation* between the highest and lowest level channels. For the system suggested above (42 db dynamic range per track and 24 db separation between levels) the effective dynamic range of the overall system would be 42 db (1 level only), 66 db (2 levels), 80 db (3 levels), 104 db (4 levels), and 128* db (5 levels) depending on the number of independent tape data channels used to record the signal (* = provided this figure does not exceed the limit set by the preamp or intermediate amplifier). Increasing effective dynamic range in this manner has serious drawbacks, however, because of the poor signal to noise ratio on the "in use" channel when the signal is just above clipping on the next higher gain channel. Spectral analysis of a record on which peak amplitudes are only 20 db above noise level would be of limited value, for example.

III. DIGITAL RECORDING VS ANALOG RECORDING

Let us interrupt our consideration of the analog system outlined above to contrast its performance with a system employing digital rather than analog recording. A 12-bit A/D converter has a 72 db resolution and can encode a 72 db dynamic range from a single output amplifier. Moreover, several output amplifiers with different gain levels can be used in a digital gain-ranging procedure that can increase the system dynamic range to the limit set by the preamplifier. The consequences of

passing from one gain range (amplifier) to the next one of lower sensitivity are not the same as for multilevel analog recording: the increment in signal amplitude corresponding to the least significant digit increases by the ratio of the gains in the higher gain and lower gain output amplifiers, but there is no increase in system (tape recorder) noise as in the case of analog recording. A small increase in word length is required to preserve the gain range information. If 20-db gain-steps were used, only four gain levels would be required to attain a dynamic range of 132 db (with 72 db resolution from a 12-bit A/D converter). Two additional bits would be required to distinguish among gain levels, increasing the required word length from 12 to 14 bits. If only 12 bits/sample is available, a 4-level 20 db separation gain-ranging system would provide 120 db dynamic range and 60 db resolution with a 10-bit A/D converter.

The obvious advantages of the digital system provide a strong incentive to find means of overcoming its principal disadvantage, the larger amount of tape required for digital recording than for analog recording with present systems.

IV. ELECTRONIC AMPLIFICATION REQUIRED FOR OPTIMUM SENSITIVITY

Returning to the consideration of the analog system, the question of sensitivity is also linked to the question of noise in the tape record/tape playback system and to available gain in the amplifier as well as to the input noise level of the amplifier (which sets the ultimate limit on sensitivity). Specifically, the seismometer output must not only exceed the input noise of the amplifier but, after amplification and recording, it must "play back" from tape at a level that is higher than the tape-speed-variation-induced noise in the record/playback system. To determine what amplification is required to raise the seismometer signal to an appropriate level for recording to attain the full potential sensitivity of the overall system, we must calculate the signal level, referred to the amplifier output (modulator input), that corresponds to the tape record/tape playback

noise level induced by tape speed variation. For this calculation, we must know the modulator sensitivity (specifically, the modulator input signal required for full modulation) and we must know (or stipulate) the dynamic range of the tape record/tape playback system. The dynamic range, DR, of the latter is the ratio of the discriminator output for full modulation, D100, to that for zero modulation D0.

In decibels, $DR = 20 \log_{10} \frac{D100}{D0}$. The noise modulation expressed in percent is:

$NP = 100 \times \frac{D0}{D100} = 100 \times 10^{-DR/20}$. NP is the modulation, in percent, that would have to be applied to the modulator in a noise-free system to produce the same discriminator output level that is observed for no modulation in the real system. Then, if the input signal to the modulator required for full modulation is MF, the input signal, MN, required to produce the "noise" modulation, NP, is

$$MN = \frac{NP}{100} \times MF = MF \times 10^{-DR/20}$$

Next, let us calculate the signal amplification required to raise the amplifier input noise, IN, to the level, MN, corresponding to a tape system dynamic range, DR.

$$AMP = \frac{MN}{IN} = \frac{MF \times 10^{-DR/20}}{IN}$$

As in an example used earlier, let us take $MF = 8.0Vp-p$ and $IN = 0.5 \mu Vp-p$, then

$$AMP = 16.0 \times 10^{6/10}^{DR/20}$$

DR	30	33	36	39	42	45	48	51	54	57	60
AMP(K)	506	358	253	180	127	90	64	45	32	23	16
Gain (db)	114	111	108	105	102	99	96	93	90	87	84

If a tape recorder with a dynamic range of 42 db is used, the high level channel amplifier must have a gain of 102 db if we wish to have the playback amplifier input noise to be at the same level as the tape record/tape playback noise. This condition optimizes the system's sensitivity to seismometer signals as well as the dynamic range with which those signals can be recorded. For a lower level channel with less

than 102 db amplifier gain, 78 db gain for example, the seismometer signal must be larger (24 db in our example) than that required for detection on the high gain (102 db) channel before it rises above tape noise level on playback.

V. 3-LEVEL AMPLIFIER DESIGN AND CHARACTERISTICS

A 3-level seismic amplifier, designed according to the principles discussed above, for multilevel analog recording on a tape system with a dynamic range of 42 db is outlined in figure 1. It corresponds to elements 2a, 2b, 2c, and 2d of the system stipulated at the beginning of this discussion:

- a. A fixed gain (12 db) preamp with an input resistance of 10K, an internal noise of $0.5\mu\text{Vp-p}$ (referred to its input), and a maximum output of 8.0Vpp.
- b. An adjustable gain intermediate amplifier (2 db to 44 db in 6 db steps) with a maximum output of 8.0Vpp.
- c. 3 fixed gain output amplifiers with gains of 50 db (Hi out), 26 db (Med out), and 2 db (Lo out), all with maximum outputs of 8.0Vpp.
For multilevel analog recording, all three would drive identical modulators with sensitivities of $\pm 100\%$ modulation for $\pm 4.0\text{V}$ input signal.
- d. 2 passive 6 db/octave bandpass coupling filters, each with a gain of -2 db within the passband, between the preamp and intermediate amplifier and between the intermediate amplifier and the paralleled inputs to the 3 output amplifiers.

As a guide to the performance of this system, the following quantities are specified at the preamp input and at the outputs of the preamp, the intermediate amplifier, the two coupling filters and the three output amplifiers:

- 1) cumulative gain
- 2) preamp "input noise" (amplified)
- 3) dynamic range (maximum output divided by the amplified preamp noise).

Multilevel seismic amplifier

0.5 μV p-p preamp "input" noise

$\pm 4.0\text{V}$ max output level for all amp stages

0-42 db gain adjustment (6db steps)

3 output levels: Hi 0db

Med -24db

Lo -48db

Dynamic Range \rightarrow — 132 db { 90 db
132 db }

Internal Noise \rightarrow 0.5 μV 2.0 μV 1.58 μV { 250.6 μV
2.0 μV } { 199.1 μV
1.58 μV }

Cumulative Gain \rightarrow 0db +12db +10db { +54 db
= { +52 db
+10 db }

Stage Gain \rightarrow 0db +12db -2db { +44 db
= -2 db { +2 db

Stage Gain \downarrow Cumul. Gain \downarrow Internal Noise \downarrow Dynamic Range \downarrow

Hi { +102 db
+96 " 62.95 mV
31.55 " { 42 db
48 db
= 84 db

Med { +78 db
+72 " 3.97 mV
1.99 " { 66 db
72 db
= 108 db

Lo { +54 db
+12 db 250.6 μV
125.3 μV
= 2.0 μV { 90 db
96 db
= 132 db

6

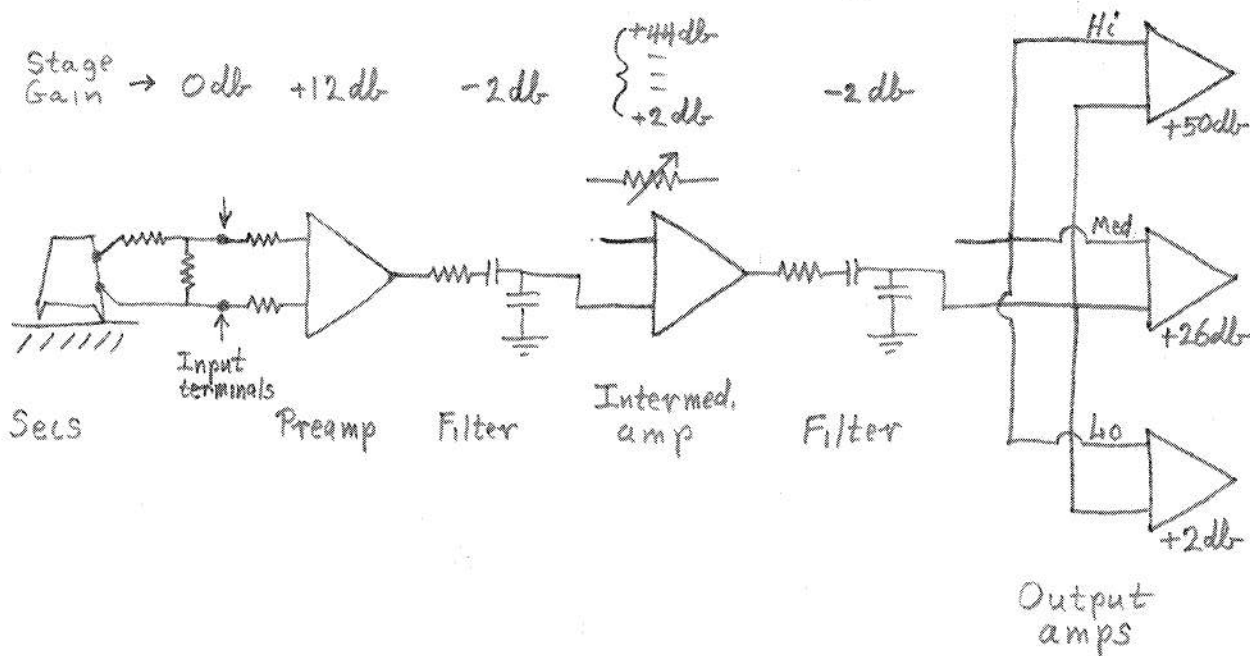

Fig 1

The gains of the individual stages are also indicated.

The large values of dynamic range indicated for the medium and low level output amplifiers, and even for the high level output amplifier when the intermediate amplifier is operating at less than maximum gain, are obviously much greater than the 42 db dynamic range of the tape recording system that the amplifier was designed to drive. When the intermediate amplifier is at maximum gain, the high level output amplifier has a dynamic range equal to that of the tape system.

VI. SIGNAL DETECTION THRESHOLDS WITH MOVING COIL SEISMOMETERS AND QUIET SITE BACKGROUND NOISE

To this point, we have been concerned primarily with the noise characteristics of the amplifier and tape record/tape playback system and how these limit the sensitivity and dynamic range of the overall system. Now let us turn to the questions: What sensitivity is desirable, and can that sensitivity be attained with simple passive seismometers driving an amplifier and recording system like that described above?

The ultimate limit on the size of the smallest earthquake (or explosion) signal that can be detected at a given site is set by the seismic background noise at the site. Even when we take care to avoid sites affected by local natural or man-made seismic noise sources, the background noise of regional and even distant origin from man made and natural sources is appreciable. The characteristics of this noise (amplitude, frequency content, temporal variation, etc.) vary considerably from place to place. The quietest sites, generally, are those on hard bedrock (granite, etc.), at distances of at least a few hundred km from the seacoast, at depths of at least a few hundred feet in mines or boreholes, and at distances of a few tens of km from major population centers and industrial activity.

Detection Threshold and Quiet Site Earth Background Noise versus Frequency

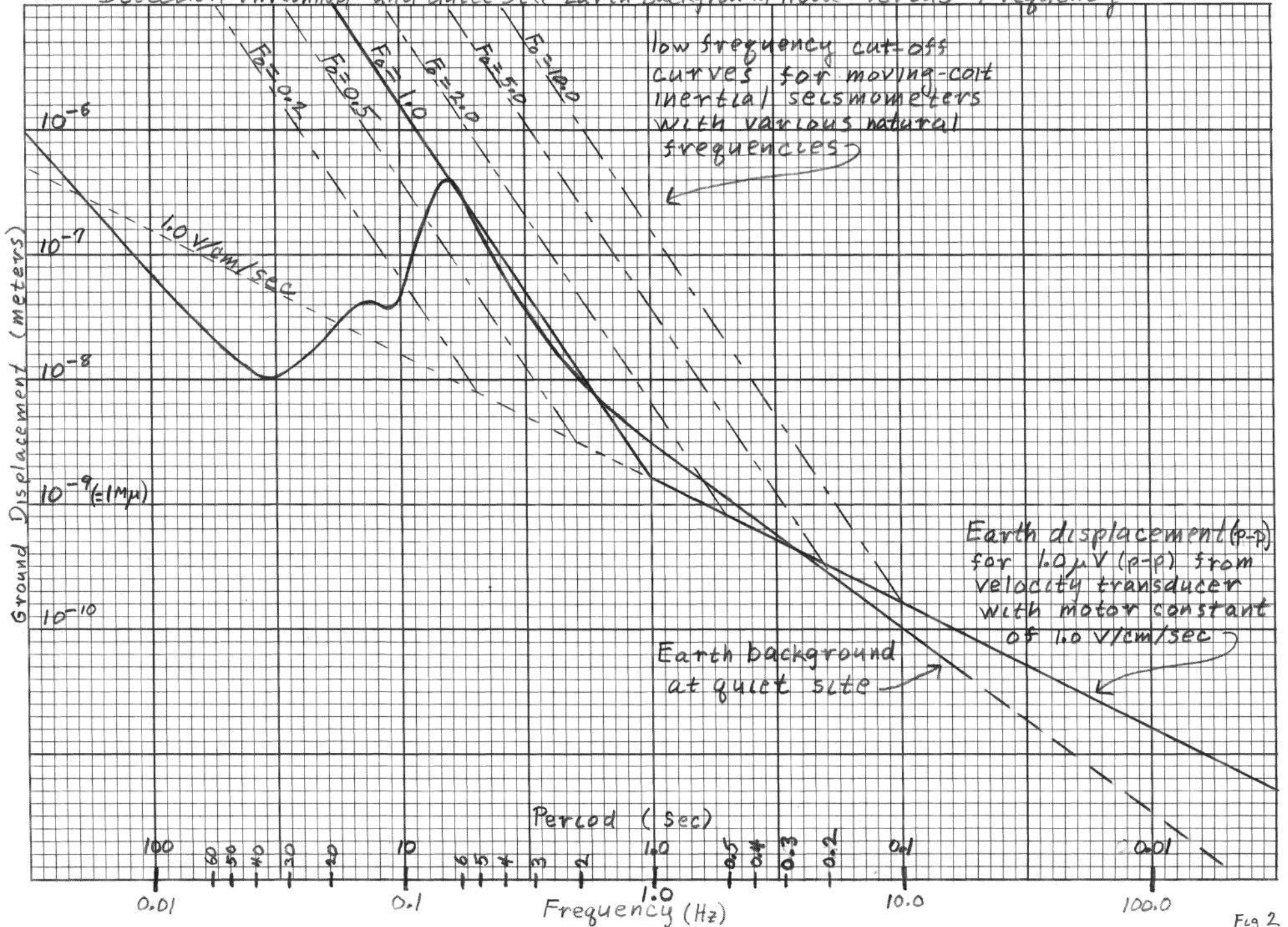

Fig 2

For maximum applicability, the seismic system we are discussing should permit the background noise at a quiet site to be detected, recorded, and played back at a level above system noise at all frequencies within the passband of the system. This condition requires that the signal produced across the amplifier input by the seismometer at a quiet site exceed the amplifier input noise at all frequencies within the system passband. We have noted that the amplifier input noise is about $0.5\mu\text{Vpp}$ when the passband is 0.1 to 30 hz, but we have not specified the noise amplitude spectrum. Sustained harmonic ground motion producing a seismometer output of $1.0\mu\text{Vpp}$ would clearly be detectable above the system noise. Thus, let us compute the amplitude of sustained harmonic ground motion that would be required to produce the required $1.0\mu\text{Vpp}$ signal at the amplifier input.

For a moving soil seismometer with natural frequency F_0 , damping β , and motor constant G_{LE} responding to a ground signal $z = h \sin 2\pi ft$, the ratio of the peak-to-peak emf across the seismometer load (i.e., amplifier input) to the peak-to-peak ground motion amplitude is:

$$\frac{EP(f)_{pp}}{2h} = \frac{2\pi f^3 G_{LE}}{[(F_0^2 - f^2)^2 + 4\beta^2 F_0^2 f^2]^{1/2}}$$

For our discussion, we shall take $G_{LE} = 1.0\text{V/cm/sec} = 10^8 \mu\text{V/m/sec}$ as the standard seismometer motor constant. It will also be convenient to use asymptotic expressions for the foregoing equation that are valid for high frequencies $f \gg F_0$ and for low frequencies $f \ll F_0$. We can then solve for the peak-to-peak amplitude of ground motion of frequency f that will produce a peak-to-peak signal of $1\mu\text{V}$ across the amplifier input.

a) For high frequencies, $f > F_0$: $(2h) = \frac{0.159 \times 10^{-8}}{f}$ meter

$$b) \quad \text{For low frequencies, } f < F_0: \quad (2h) = \frac{0.159 \times 10^{-8}}{f} \times \left(\frac{F_0}{f}\right)^2 \text{ meter}$$

Ground motion detection threshold curves based on these relationships are plotted in figure 2 for seismometers with different natural frequencies but the same motor constant ($G_{LE} = 1.0 \text{ V/m/sec}$). In each case equation a) is used for $f > F_0$ and equation b), for $f < F_0$.

Also plotted in figure 2 for comparison is a curve depicting "earth background at a quiet site (averaged over time and frequency)" from "Seismic Research Observatories: Upgrading the Worldwide Seismic Data Network" by J. Peterson and N Orsini, EOS, vol 57, pp 548 to 556, August 1976. That curve shows earth displacement (meters) vs earth period (seconds) and is based on observations at several very quiet sites, including Queen Creek Mine, Arizona. (We must analyze the manner in which this noise curve was obtained before we can believe that it is in fact directly comparable with the detection threshold curves that are also plotted in figure 2).

The detection threshold curve for a standard moving coil seismometer with a natural frequency of 1 hz follows the quiet site background noise curve very closely for frequencies between about 0.2 hz and 10 hz. The noise curve sinks gradually below the detection curve for frequencies above 10 hz, but it falls away very abruptly at frequencies below 0.2 hz.

For seismometers with motor constants of 1 V/cm/sec but with natural frequencies higher than 1 hz, the detection threshold curves depart rapidly from the background noise curve for ground motion frequencies below the seismometer natural frequencies. In such cases internal system noise rather than earth background noise sets the limit on the smallest detectable seismic signals.

A passive moving coil (velocity transducer) accelerometer, essentially a moving coil seismometer with a natural frequency of 10 hz or higher, is relatively insensitive to ground displacement at frequencies that predominate in microearthquakes

and is therefore not well suited for recording them. The foregoing analysis (of seismometers) does not apply to force-balance type accelerometers. An independent analysis of the signal to noise ratio of such instruments as a function of frequency and the dynamic range of seismic systems employing them would be required to permit them to be compared with the system discussed above.