

Failure stress criteria for composite resin

Citation for published version (APA):

Groot, de, R., Haan, de, Y. M., Dop, G. J., Peters, M. C. R. B., & Plasschaert, A. J. M. (1987). Failure stress criteria for composite resin. *Journal of Dental Research*, 66(12), 1748-1752.

Document status and date:

Published: 01/01/1987

Document Version:

Publisher's PDF, also known as Version of Record (includes final page, issue and volume numbers)

Please check the document version of this publication:

- A submitted manuscript is the version of the article upon submission and before peer-review. There can be important differences between the submitted version and the official published version of record. People interested in the research are advised to contact the author for the final version of the publication, or visit the DOI to the publisher's website.
- The final author version and the galley proof are versions of the publication after peer review.
- The final published version features the final layout of the paper including the volume, issue and page numbers.

[Link to publication](#)

General rights

Copyright and moral rights for the publications made accessible in the public portal are retained by the authors and/or other copyright owners and it is a condition of accessing publications that users recognise and abide by the legal requirements associated with these rights.

- Users may download and print one copy of any publication from the public portal for the purpose of private study or research.
- You may not further distribute the material or use it for any profit-making activity or commercial gain
- You may freely distribute the URL identifying the publication in the public portal.

If the publication is distributed under the terms of Article 25fa of the Dutch Copyright Act, indicated by the "Taverne" license above, please follow below link for the End User Agreement:

www.tue.nl/taverne

Take down policy

If you believe that this document breaches copyright please contact us at:

openaccess@tue.nl

providing details and we will investigate your claim.

Failure Stress Criteria for Composite Resin

R. DE GROOT, M.C.R.B. PETERS, Y.M. DE HAAN¹, G.J. DOP², and A.J.M. PLASSCHAERT

Department of Cariology and Endodontology, Subfaculty of Dentistry, University of Nijmegen, PO Box 9101, 6500 HB Nijmegen, The Netherlands; ¹Materials Science Group, Department of Civil Engineering, Delft University of Technology, Stevinweg 1, 2628 CN Delft, The Netherlands; and ²Division of Fundamentals of Mechanical Engineering, Department of Mechanical Engineering, Eindhoven University of Technology, PO Box 513, 5600 MB Eindhoven, The Netherlands

In previous work (Peters and Poort, 1983), the stress distribution in axisymmetric models of restored teeth was analyzed by finite element analysis (FEA). To compare the tri-axial stress state at different sites, they calculated the Von Mises equivalent stress and used it as an indication for weak sites. However, the use of Von Mises' theory for material failure requires that the compressive and tensile strengths be equal, whereas for composite resin the compressive strength values are, on the average, eight times larger than the tensile strength values. The objective of this study was to investigate the applicability of a modified Von Mises and the Drucker-Prager criterion to describe mechanical failure of composite resin. In these criteria, the difference between compressive and tensile strength is accounted for. The stress criteria applied to an uni-axial tensile stress state are compared with those applied to a tri-axial tensile stress state. The uni-axial state is obtained in a Rectangular Bar (RB) specimen and the tri-axial state in a Single-edge Notched Bend (SENB) specimen with a chevron notch at midspan. Both types of specimens, made of light-cured composite, were fractured in a three-point bend test. The size of the specimens was limited to 16 mm × 2 mm × 2 mm (span, 12 mm). Load-deflection curves were recorded and used for linear elastic FEA. The results showed that the Drucker-Prager criterion is a more suitable criterion for describing failure of composite resins due to multi-axial stress states than are the Von Mises criterion and the modified Von Mises criterion.

J Dent Res 66(12):1748-1752, December, 1987

Introduction.

Composite resin as restorative material in posterior teeth requires special properties, such as high mechanical strength, high abrasion resistance, and good adhesion to tooth structure to withstand chewing forces, as well as low polymerization shrinkage, stability in water, and color stability. In this study, we shall concentrate on the mechanical strength. Recently, the stress distribution in loaded teeth, restored with amalgam, was studied (Peters and Poort, 1983) by FEA. Principal stresses (σ_1 , σ_2 , σ_3) and Von Mises' equivalent stress (σ_{eq1}) were compared at different sites. The equivalent stress was obtained from the equation of criterion #1 (Appendix):

$$\sigma_{eq1} = (-3J_2')^{1/2} \quad (1)$$

with J_2' the second invariant of the deviatoric stress tensor:

$$J_2' = -1/6 [(\sigma_1 - \sigma_2)^2 + (\sigma_2 - \sigma_3)^2 + (\sigma_3 - \sigma_1)^2] \quad (2)$$

where σ_1 , σ_2 , and σ_3 are the principal stresses.

The critical value of σ_{eq1} (identical with yield stress σ_Y) can be determined for the uni-axial state with a tensile test. In the case of brittle failure, the tensile strength is assumed to be identical with the yield stress. According to criterion #1, failure will occur in a three-dimensional structure in a region where the calculated σ_{eq1} exceeds the yield stress σ_Y . Because composite resins fracture in a more or less brittle way, the validity of a yield criterion is uncertain. Moreover, the compressive

strength of composite resins is about eight times larger than the tensile strength, whereas they are treated equally by criterion #1. The aim of this study was to investigate the applicability of three stress failure criteria (Von Mises, criterion #1; modified Von Mises, criterion #2; and Drucker-Prager, criterion #3) to brittle fracture of a composite resin. Criterion #1 was modified to obtain criterion #2 by addition of the hydrostatic stress. This addition results in a criterion which takes into account the difference between compressive and tensile strength of a composite. The equivalent stress (σ_{eq2}) was obtained from the equation of criterion #2 (Appendix):

$$\sigma_{eq2} = \frac{(k-1)}{2k} J_1 + \frac{[(k-1)^2 J_1^2 - 12 J_2' k]^{1/2}}{2k} \quad (3)$$

where J_1 is the first invariant of the stress tensor:

$$J_1 = (\sigma_1 + \sigma_2 + \sigma_3) \quad (4)$$

and k the ratio between compressive and tensile strength.

Criterion #2 (Williams, 1973) is suitable for describing the failure of polymers, which are like the resin part of the composite without filler particles. Another criterion (Drucker-Prager, criterion #3; Drucker and Prager, 1952) may account for the ratio of compressive to tensile strength. It is commonly used in the field of soil mechanics to describe failure or deformation of a body consisting of soil particles. The filler particles of the composite without the resin can be considered as such. The equivalent stress (σ_{eq3}) was obtained from the equation of criterion #3 (Appendix):

$$\sigma_{eq3} = \frac{k-1}{2k} J_1 + \frac{k+1}{2k} (-3J_2')^{1/2} \quad (5)$$

A failure criterion, describing only material properties, should for one single set of material parameters be able to predict failure in an uni-axial as well as any tri-axial stress state. A failure criterion can be represented by a surface in the three-dimensional stress space with the three principal stresses on the co-ordinate axes. For such a surface to be determined experimentally, a large number of different stress states should be investigated. In this study, however, a comparison has been made between failure described according to criteria #1, #2, and #3 in an uni-axial and a tri-axial stress state (all three principal stresses are positive). A Rectangular Bar (RB) specimen (Fig. 1a), fractured in a three-point bend test, has an uni-axial stress state at the site where failure starts, and a Single-edge Notched Bend (SENB) specimen with a chevron notch (Fig. 1b) has a tri-axial stress state. In general, the stress state in a structure (a tooth in the clinical case) is more likely to be tri-axial than uni-axial; therefore, the SENB specimen seems to be more consistent with clinical stress states. This type of specimen for controlled fracture experiments is often used to determine parameters of fracture mechanics such as work-of-fracture (Tattersall and Tappin, 1966; Rasmussen *et al.*, 1973; Rasmussen *et al.*, 1976; Rasmussen, 1978). This study is aimed at determination of a failure criterion for composite resin. A

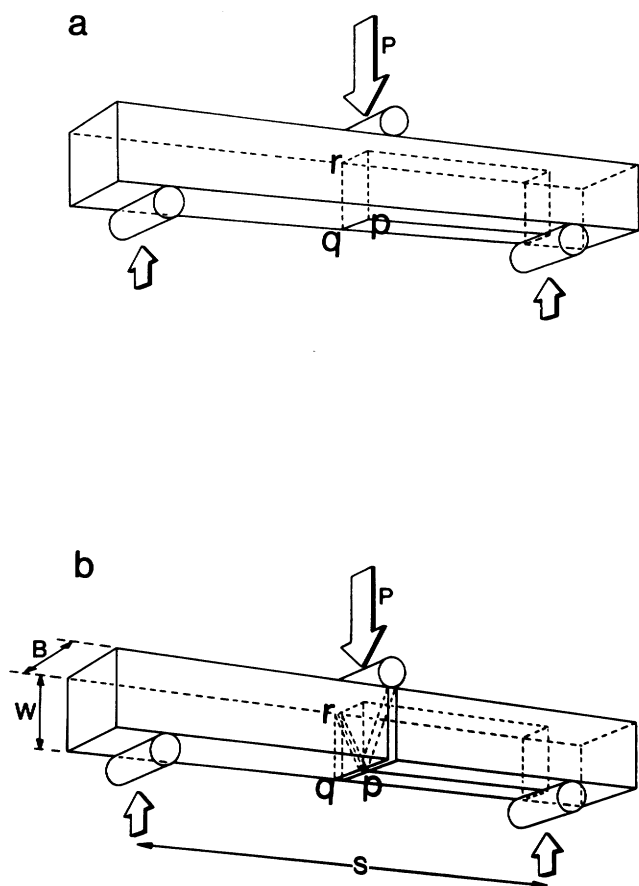

Fig. 1 — (a) Rectangular Bar in three-point bend experiment. (b) Single-edge Notch Bend specimen with chevron notch. P, load; S, span; B, thickness; W, width.

failure criterion is necessary to support prediction of mechanical failure when FEA of a composite-restored tooth is used.

Materials and methods.

Experiments.—Composite (Silux®, a bis-GMA resin with colloidal silica particles; average size, 0.04 μm; filler content, 51% by weight, according to the manufacturer; batch 060884, univ 4XY1, 3M Co., St. Paul, MN) was inserted into a stainless steel mold and covered with a glass plate, whereafter the specimens (16 mm × 2 mm × 2 mm) were polymerized by visible light (Translux®, Kulzer & Co. GmbH, Bereich Dental, D-6382 Friedrichsdorf 1, Federal Republic of Germany). After five min, the specimens were stored in tap water at room temperature for from 24 to 28 hr, during which period they were taken from the water for about five min so that a chevron notch could be cut by means of a diamond disk (537/220 H superdiaflex Horico®, Hopf Ringleb & Co. GmbH, Berlin 45, Federal Republic of Germany) (diameter, 22 mm; thickness, 0.15 mm) and water coolant. The bars were fractured in a three-point bend test by means of an Instron testing machine, at a cross-head speed of 0.5 mm/min. The span of the support (S) of approximately 12 mm was determined with a measuring microscope. Load-deflection (P,u) curves were recorded. The load at fracture (P_c) was defined as the highest load. The thickness (B) and the width (W) of the specimens were measured with a micrometer. For each RB specimen, the Young's mod-

ulus (E) was calculated according to:

$$E = \frac{P S^3}{4 B W^3 u} (1 + 3(1 + \nu/2) \frac{W^2}{S^2}) \quad (6)$$

(Williams, 1973). The correction factor has a value of 0.096 (using, for Poisson's ratio, $\nu = 0.3$, $W = 2$, and $S = 12$) and is necessary because the width is not small compared with the span. The values E of each specimen were averaged. For RB testing, 12 specimens were used.

A reduced number of SENB specimens (5) was caused by the complicated manufacturing of these specimens.

The fracture surfaces were examined, and the distance from the notch tip to the outer surface (c) was measured with a measuring microscope so that the accuracy of the cutting could be evaluated.

FEA calculations.—For reasons of symmetry, the modeling and the calculation of the three-dimensional (3-D) stress distribution with FEA can be restricted to one-quarter (6 mm × 1 mm × 2 mm) of the RB and SENB bars (element mesh shown in Figs. 2a and 2b) by introduction of the appropriate boundary conditions. For analysis of the SENB specimen, 3-D modeling is necessary. The number of elements was 12 and 111 for the RB and SENB models, respectively. Care was taken to increase the number of elements for the SENB model in the notch tip region for reasons of accuracy. Fig. 3 depicts the distribution of elements as a function of distance from

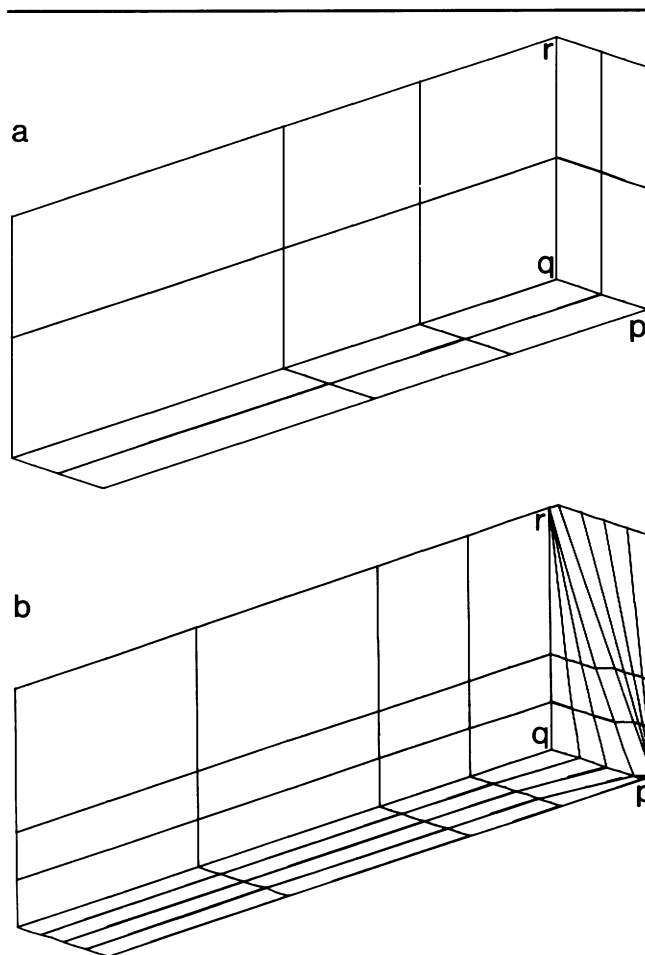

Fig. 2 — (a) RB model: quarter of the bar, as used for FEA calculations. (b) SENB model: quarter of the bar, as used for FEA calculations.

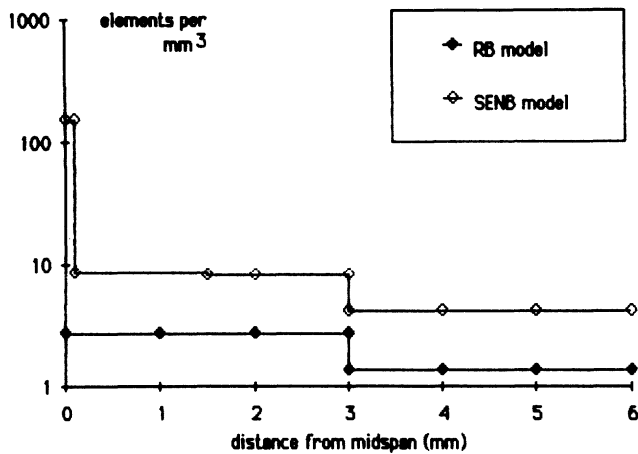

Fig. 3 — Distribution of number of elements used to model the RB and SENB specimens, as a function of distance from midspan.

midspan. The type of element used was a 3-D isoparametric 20-node brick. The assigned modulus of elasticity ($E = 3.70 \text{ GN/m}^2$) resulted from the experiments, whereas the Poisson's ratio was taken to be 0.3, which value is supported by values for composites reported by Finger (1974) and Whiting and Jacobson (1980) ranging from 0.23 to 0.33. By assumption of linear elastic material properties and geometric linearity, a linear relationship exists between both calculated deflections and stresses vs. applied load. The deflection was prescribed, and the reaction force in the loading point was derived from FEA calculations. The equivalent stresses according to criteria #1, #2, and #3 were calculated by FEA for the region where failure initiation was observed in the experiments. For the RB and SENB specimens, this region was situated at midspan, at the side opposite the applied load. By replacement of the reaction force with the measured fracture load (P_c), the critical values σ_{eq1c} , σ_{eq2c} , and σ_{eq3c} of the equivalent stresses were obtained. The ratio ($k = 8$) between compressive and tensile strength was computed from the compressive and tensile strengths as provided by the manufacturer. The influence of k on the calculated equivalent stress was investigated by varying k from 5 to 10. Because the thickness (B) and width (W) measured on the experimental specimens deviated from the values used in the FEA calculations ($B = 2 \text{ mm}$ and $W = 2 \text{ mm}$), a correction term based on this deviation was applied to the stresses calculated by FEA.

Results.

Experiments.—The load-deflection curves (example in Fig. 4) showed a linear elastic behavior of the specimens until fracture. For the RB specimens, the load suddenly dropped to zero. For the SENB specimens, controlled fracture curves were obtained. In this way, it was possible to quantify the work-of-fracture by calculating the area under the load-deflection curve (Tattersall and Tappin, 1966).

The measured value of the span (S) was 11.98 mm. The load at fracture (P_c) is given in the Table. The average values of the thickness (B) and the width (W) of the specimens are given in the Table to show the deviation from the values assumed in the FEA calculation. The highest value of the measured distance (c) from the notch tip to the surface of the specimen was 0.074 mm. The calculation of the modulus of elasticity is based on equation (6) and yields $E = 3.70 \pm 0.35 \text{ GPa}$.

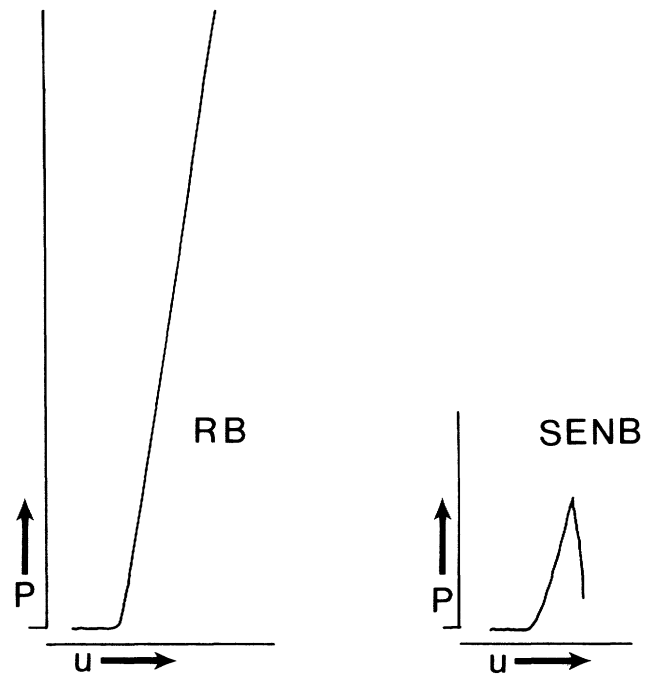

Fig. 4—Qualitative example of load-deflection curves of a Rectangular Bar and Single-edge Notch Bend specimen showing linear elastic behavior until fracture.

TABLE
THE RESULTS OF MEASUREMENTS AND CALCULATIONS

	Specimens	
	RB N = 12	SENB N = 5
Measurements		
P_c (N)	23.6 ± 2.3	4.63 ± 0.11
B (10^{-3}m)	2.043 ± 0.033	2.031 ± 0.013
W (10^{-3}m)	2.102 ± 0.058	2.121 ± 0.063
FEA calculations		
σ_{eq1c} (MPa)	44.4 ± 4.4	34.9 ± 4.5
σ_{eq2c} (MPa)	48.3 ± 4.8	71.5 ± 10.7
Σ_{eq3c} (MPa)	46.6 ± 4.7	54.3 ± 8.1

*significantly different at a level of $p = 0.005$.

° not significantly different at a level of $p = 0.005$.

Fracture load (P_c), thickness (B), width (W), and critical values (σ_{eq1c} , σ_{eq2c} , and σ_{eq3c}) of equivalent stresses according to criteria #1 (Von Mises), #2 (modified Von Mises), and #3 (Drucker-Prager) for RB (rectangular bar) and SENB (single-edge notched bend) specimens. Average values \pm standard deviation; N = number of specimens.

FEA calculations.—The critical values of these equivalent stresses (σ_{eq1c} , σ_{eq2c} , and σ_{eq3c}) in the fracture region, according to criteria #1, #2, and #3 (obtained from FEA on the RB and SENB models) are given in the Table. A Student t test showed that critical values of the equivalent stresses according to Von Mises and modified Von Mises criteria measured with RB specimens were significantly different from critical values of equivalent stresses measured with SENB specimens at a level of $p = 0.005$. This was not the case for the Drucker-Prager criterion. The influence of variation in k on the calculated equivalent stresses was small. The equivalent stress according to criterion #2 for $k = 10$ was 8% larger than for $k = 5$, while for criterion #3 this difference was only 4%.

Discussion.

The objective of this study was to investigate the applicability of several failure criteria to composite resin. Two stress states were realized in RB and SENB specimens. So that a fair comparison would be ensured, the two types of specimens were stored under identical conditions. For clinical use of an established criterion, more realistic conditions are necessary for determination of the parameters. For example, attention should be paid to water sorption and hydrolytic degradation of aging composite resin.

In general, the strength of dental materials is tested by application of uni-axial stress states (tension or compression) to the test specimens. In 3-D dental structures, a tri-axial stress state is encountered. Therefore, a failure criterion for composite should be essentially tri-axial.

Examination of the fracture surface of the SENB specimens revealed that the tip of the chevron notch was always less than 0.074 mm from the edge, which is 4% of the width. Therefore, it was concluded that the experimental geometry of the specimens could be represented by the SENB model as used in the FEA. Cutting the chevron notches in bars will never produce exact SENB specimens. The load-deflection curves supported the correctness of the assumption of the linear material properties for the FEA calculations. The experimentally determined modulus of elasticity falls into the range (3.3–5.3 GPa) reported by Reinhardt and Vahl (1983).

Any valid failure criterion for composite resins depends on a number of material parameters which should be the same for all possible stress states. The criteria investigated in this paper are all two-parameter criteria for which the ratio k and the critical values of the various equivalent stresses have been chosen. Materials such as composite resins have a larger compressive than tensile strength, which means that $k > 1$. In the Von Mises criterion, the parameter k must be equal to 1. For this reason, this criterion is basically not suitable for composite resins. Composite resins typically have k -values within the range $5 < k < 10$. A proper stress failure criterion should yield the same value for the critical values of the equivalent stress for all possible tri-axial stress states, including our uni-axial and tri-axial stress states (Table). The remaining criteria (modified Von Mises and Drucker-Prager) can use realistic values for k . The results obtained for the considered criteria show that the difference in critical equivalent stresses for the two stress states (uni-axial vs. tri-axial) is minimal for the Drucker-Prager criterion. For this reason, the Drucker-Prager criterion seems to be a more suitable criterion for use as a general criterion for mechanical failure of composite resins subjected to complex stress patterns.

Acknowledgments.

The authors would like to thank Dr. Ir. P.G.Th. van der Varst for his contribution to the text and Dr. H.A.J. Reukers for his experimental assistance. This research was part of the research program: Restorations and Restorative Materials.

Appendix.

Von Mises' yield criterion states that yielding will occur when the second invariant of the deviatoric stress tensor (J_2') reaches a critical value, or:

$$p(-J_2') = 1 \quad (A1)$$

with:

$$J_2' = -1/6 [(\sigma_1 - \sigma_2)^2 + (\sigma_2 - \sigma_3)^2 + (\sigma_3 - \sigma_1)^2] \quad (A2)$$

and σ_1 , σ_2 , and σ_3 principal stresses and p a parameter. In the case of simple tension, yielding (σ_Y is yield strength) will occur when:

$$\sigma_1 = \sigma_Y \text{ and } \sigma_2 = \sigma_3 = 0. \quad (A3)$$

Substitution in eq. A1 gives:

$$p = 3 / \sigma_Y^2. \quad (A4)$$

Now, knowing p , the interpretation of Von Mises becomes clear. Substitution of A4 into A1 leads to:

$$\sigma_Y^2 = 3 (-J_2'). \quad (A5)$$

Therefore, the aforementioned critical value is equal to σ_Y^2 . By defining an equivalent stress (σ_{eq1}) as:

$$\sigma_{eq1} = (-3 J_2')^{1/2}, \quad (A6)$$

Von Mises' criterion states that yielding will occur when the equivalent stress reaches a critical value ($\sigma_{eq1c} = \sigma_Y$). Notice that J_2' in eq. A5 denotes the value of J_2' at the moment of failure, where J_2' in eq. A6 can have any value below the critical value.

According to Williams (1973), for materials with different compressive and tensile strength values, Von Mises' yield criterion can be modified by adding the hydrostatic stress:

$$qJ_1 + p(-J_2') = 1, \quad (A7)$$

where p and q are parameters and J_1 the first invariant of the stress tensor:

$$J_1 = (\sigma_1 + \sigma_2 + \sigma_3). \quad (A8)$$

p and q can be expressed in terms of the yield stresses in simple tension and simple compression, σ_{Yt} and σ_{Yc} , respectively:

$$q \sigma_{Yt} + p / 3 \sigma_{Yt}^2 = 1 \quad (A9a)$$

$$-q \sigma_{Yc} + p / 3 \sigma_{Yc}^2 = 1 \quad (A9b)$$

Hence:

$$q = \frac{\sigma_{Yc} - \sigma_{Yt}}{\sigma_{Yc}\sigma_{Yt}} \text{ and } p = \frac{-3}{\sigma_{Yc}\sigma_{Yt}} \quad (A10a/b)$$

For known ratio of compressive to tensile strength:

$$k = \sigma_{Yc}/\sigma_{Yt}, \quad (A11)$$

and substitution of eq. A10a, A10b, and A11 into eq. A7 gives:

$$k \sigma_{Yt}^2 - (k-1)\sigma_{Yt}J_1 + 3J_2' = 0. \quad (A12)$$

Solving eq. A12 for σ_{Yt} :

$$\sigma_{Yt\pm} = \frac{(k-1)J_1 \pm [(k-1)^2J_1^2 - 12J_2'k]^{1/2}}{2k} \quad (A13)$$

(because strength values need to be positive, only the σ_{Yt+} value can be accepted).

Again, an equivalent stress (σ_{eq2}) can be defined:

$$\sigma_{eq2} = \frac{(k-1)J_1 \pm [(k-1)^2J_1^2 - 12J_2'k]^{1/2}}{2k} \quad (A14)$$

Notice that J_1 and J_2' in eq. A13 denote the values of J_1 and J_2' at the moment of failure, where J_1 and J_2' in eq. A14 can have any value below the critical value.

The Drucker-Prager criterion (Drucker and Prager, 1952) reads as follows:

$$qJ_1 + r(-J_2')^{1/2} = 1. \quad (A15)$$

An analogue derivation, as given for the modified Von Mises criterion, leads to:

$$\sigma_{eq3} = \frac{k-1}{2k} J_1 + \frac{k+1}{2k} (-3J_2')^{1/2} \quad (A16)$$

List of Symbols.

symbol	unit	description
B	(m)	thickness of the bar
c	(m)	distance from surface to notch tip
E	(Pa)	modulus of elasticity
FEA		finite element analysis
J ₁	(Pa)	first invariant of stress tensor
J ₂ '	(Pa ²)	second invariant of deviatoric stress tensor
k		ratio of compressive and tensile strength
p	(Pa ⁻²)	parameter in stress criterion
P	(N)	load at midspan
P _c	(N)	fracture load
q	(Pa ⁻¹)	parameter in stress criterion
r	(Pa ⁻¹)	parameter in stress criterion
RB		Rectangular Bar specimen
S	(m)	span of the support
SENB		Single-edge Notched Bend specimen
u	(m)	deflection of bar at midspan
W	(m)	width of the bar
σ _{eq1}	(Pa)	equivalent stress criterion #1 (Von Mises)
σ _{eq2}	(Pa)	equivalent stress criterion #2 (modified Von Mises)
σ _{eq3}	(Pa)	equivalent stress criterion #3 (Drücker-Prager)
σ _{eq1c}	(Pa)	critical value of σ _{eq1}
σ _{eq2c}	(Pa)	critical value of σ _{eq2}

σ _{eq3c}	(Pa)	critical value of σ _{eq3}
σ _Y	(Pa)	yield stress
σ _{Yc}	(Pa)	yield stress in simple compression
σ _{Yt}	(Pa)	yield stress in simple tension
σ ₁	(Pa)	principal stress
σ ₂	(Pa)	principal stress
σ ₃	(Pa)	principal stress

REFERENCES

- DRÜCKER, D. and PRAGER, W. (1952): Soil Mechanics and Plastic Analysis or Limit Design, *Q Appl Math* 10: 157-165.
- FINGER, W. (1974): Der Elastizitätsmodul von Composite-Füllungs-materialien, *Schweiz Mschr Zahnheilk* 84: 648-661.
- PETERS, M.C.R.B. and POORT, H.W. (1983): Biomechanical Stress Analysis of the Amalgam-Tooth Interface, *J Dent Res* 62: 358-362.
- RASMUSSEN, S.T. (1978): Fracture Studies of Adhesion, *J Dent Res* 57: 11-20.
- RASMUSSEN, S.T.; PATCHIN, R.E.; and SCOTT, D.B. (1973): Fracture Properties of Amalgam and a Composite Resin, *IADR Progr & Abst* 52: 68, Abst. No. 40.
- RASMUSSEN, S.T.; PATCHIN, R.E.; SCOTT, D.B.; and HEUER, A.H. (1976): Fracture Properties of Human Enamel and Dentin, *J Dent Res* 55: 154-164.
- REINHARDT, K.-J. and VAHL, J. (1983): Die Bedeutung des Elastizitätsmoduls für die Randständigkeit von Kompositen (1. Mitteilung), *Dtsch Zahnärztl Z* 39: 946-948.
- TATTERSALL, H.G. and TAPPIN, G. (1966): The Work of Fracture and its Measurement in Metals, Ceramics and other Materials, *J Mater Sci* 1: 296-301.
- WHITING, R. and JACOBSON, P.H. (1980): A Non-destructive Method of Evaluating the Elastic Properties of Anterior Restorative Materials, *J Dent Res* 59: 1978-1984.
- WILLIAMS, J.G. (1973): **Stress Analysis of Polymers**, London: Longman Group Limited, p. 70, p. 129.