



AALBORG UNIVERSITY
DENMARK

Aalborg Universitet

Fault Estimation

A Standard Problem Approach

Stoustrup, Jakob; Niemann, H.

Published in:
International Journal of Robust and Nonlinear Control

DOI (link to publication from Publisher):
[10.1002/rnc.716](https://doi.org/10.1002/rnc.716)

Publication date:
2002

Document Version
Tidlig version også kaldet pre-print

[Link to publication from Aalborg University](#)

Citation for published version (APA):
Stoustrup, J., & Niemann, H. (2002). Fault Estimation: A Standard Problem Approach. *International Journal of Robust and Nonlinear Control*, 649-673. <https://doi.org/10.1002/rnc.716>

General rights

Copyright and moral rights for the publications made accessible in the public portal are retained by the authors and/or other copyright owners and it is a condition of accessing publications that users recognise and abide by the legal requirements associated with these rights.

- Users may download and print one copy of any publication from the public portal for the purpose of private study or research.
- You may not further distribute the material or use it for any profit-making activity or commercial gain
- You may freely distribute the URL identifying the publication in the public portal -

Take down policy

If you believe that this document breaches copyright please contact us at vbn@aub.aau.dk providing details, and we will remove access to the work immediately and investigate your claim.

Fault estimation—a standard problem approach

J. Stoustrup^{1,*†} and H. H. Niemann^{2,‡}

¹*Department of Control Engineering, Aalborg University, DK-9220 Aalborg, Denmark*

²*Ørsted-DTU, Automation, Building 326, Technical University of Denmark, DK-2800 Kgs. Lyngby, Denmark*

SUMMARY

This paper presents a range of optimization based approaches to fault diagnosis. A variety of fault diagnosis problems are reformulated in the so-called standard problem set-up introduced in the literature on robust control. Once the standard problem formulations are given, the fault diagnosis problems can be solved by standard optimization techniques. The proposed methods include (1) fault diagnosis (fault estimation, (FE)) for systems with model uncertainties; FE for systems with parametric faults, and FE for a class of nonlinear systems. Copyright © 2002 John Wiley & Sons, Ltd.

1. INTRODUCTION

The early history of the literature on fault detection and isolation (FDI) had a number of parallels to the literature on classical control theory. In control theory, a wide range of fairly different control problems had been formulated by many authors, and a vast number of methods had been proposed to solve one or several of these problems. A similar situation was dominant in the early FDI literature, and to some extent this is still the case.

In control theory, it was a major breakthrough from this perspective, when a *unified* approach to a large number of control problems was suggested in terms of the so-called *standard problem formulation* in robust control (see e.g. Reference [1]). In very few words, the main idea was to launch a two stage solution: first to formulate an abstract optimization problem, that was general enough to comprise many significant control problems; second to pursue a general solution to this optimization problem, independent of specific control problems. The most well-known success story along this line of thinking was probably Reference [2].

Since a somewhat similar situation was predominant in the FDI literature, it was rather obvious to try a similar attempt in this area. In fact, it turned out that the very approach from robust control immediately carried over, and that the standard problem formulation of robust control had a lot to offer with respect to FDI problems.

*Correspondence to: J. Stoustrup, Department of Control Engineering, Aalborg University, DK-9220 Aalborg, Denmark

†E-mail: jakob@control.auc.dk

‡E-mail: hhn@oersted.dtu.dk

Actually, FDI problems were already formulated in a standard set-up, before the celebrated two Riccati equation based \mathcal{H}_∞ design method [2] was available, see Reference [3]. When the \mathcal{H}_∞ design method had become available, a standard problem formulation for design of fault detectors were pursued, e.g. in Reference [4]. A standard problem set-up for fault detection/estimation was presented in Reference [5]. Also, the monograph [6] includes elaborate studies on robust estimation. The standard set-up has also been applied in [7], where examples has been considered.

Apart from the \mathcal{H}_∞ approach, a method that used the standard set-up and applied the ℓ_∞ design method for the design of controller/residual generator appeared in Reference [8]. A method that combined a classical FDI approach with \mathcal{H}_∞ design was suggested in Reference [9], where a factorization of the system was made and then subsequently \mathcal{H}_∞ design was applied to design a residual generator.

In Reference [10] a formulation of the design problem was made for control and FDI in the standard set-up followed by an \mathcal{H}_2 design and a μ synthesis of the design problem. This paper included some examples. A real application example has also been considered in Reference [11]. A separation result was shown for the combined design of controller and FDI in Reference [12]. The result showed that a controller does *not* obscure information for a FDI filter—provided that a good model is known. Below, we shall qualify and generalize these results.

Recently, a monograph on FDI, [13], appeared. This book includes a section dealing with using fault estimation in the standard set-up—design by the \mathcal{H}_∞ method. The combined set-up for FDI and control is also considered in this section. An approach, using the standard set-up in connection with design of FDI and control in the same line as in the book can be found in [14]. Another monograph [15], comprises apart from an elaborate survey on the existing theory, several practical issues on FDI. A standard problem approach to sensitivity optimization was considered in References [16,17]. FDI for time-varying systems was considered in Reference [18].

In this paper, we shall present a number of methods, using the standard problem formulation to address FDI problems. The objective is three-fold: to present a few new results; to give an overview of the state-of-the-art in this area; and finally to provide some hints on how to use this approach in practice, as there exists a number of pit-falls in this area as well as some handy tricks.

To the latter end, let it immediately be stated, that we assume throughout in the paper (where not explicitly stated), that appropriate dynamical weightings have been incorporated in the plant models to account for: disturbance models; fault signatures; design specifications; reference models; frequency variation of uncertainty models; etc. Let us emphasize at this point, that e.g. an \mathcal{H}_∞ design which do not include some complementary weightings to handle fundamental trade-offs and interpolation constraints tend to give absurd results. The issue of weight selection goes beyond the scope of this paper, so we would like to refer the reader to the rich literature on robust control. This does absolutely not mean, however, that the issue is unimportant.

Three categories of standard problem approaches will be presented below:

- FDI for systems with model uncertainty considered in Section 3
- FDI for systems with parametric uncertainty considered in Section 4
- FDI for a class of nonlinear systems considered in Section 5.

In the three papers [19–21], a combined set-up for both feedback and fault detection filter design problem has been considered. The design set-up is shown in Figure 1, where a standard

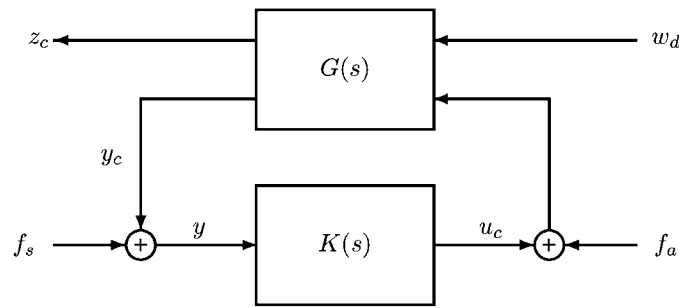

Figure 1. Control system with actuator fault, f_a , and sensor fault, f_s .

formulation is applied [1]. A complete analysis of the combined feedback controller/fault detection filter has been given in Reference [21] for both nominal systems as well as for uncertain systems. The results of this analysis is that there is a separation between the design of the feedback controller and the fault detection filter in the nominal case which does not exist in the uncertain case. The reason for this missing separation in the uncertain case is that there is a trade-off between performance in the feedback loop and performance for the fault detection filter.

By using the set-up shown in Figure 1, we are looking at both the feedback controller and the fault detection filter at the same time. The other approach in fault detection is to consider only the system without taking care of how the control signal is calculated. This set-up has been considered in several papers, see e.g. [22–24], and the references therein. The main issue in Section 3 is to give an analysis of the FDI design problem both in the case when the relation between u and y is known and when it is not known. Nominal systems as well as uncertain systems will be considered.

In the classical approach to FDI, faults are most frequently modelled as additive exogenous signals.

This perspective is highly relevant to FDI problems, but leaves unanswered the following problem: how are faults detected that are not associated with sensors and actuators, but rather with internal parameter variations? How are the situation detected early, when oil is leaking in a hydraulic system, or when the rotor in an induction motor is overheated? Such fault detection problems cannot directly be described by using the standard FDI description by an additive description, [19,24,25]. Instead, a parametric description of the system variation needs to be applied in connection. This problem is the subject of Section 4. The approach taken fits very well with the uncertainty descriptions given in the papers mentioned above and in this paper. However, dynamic model uncertainty descriptions are not explicitly integrated in the models described below for reasons of clarity.

Another class of processes where sensitive FDI designs might lead to frequent false alarms, are those processes that are subject to substantial *unknown* nonlinear dynamics. However, in the current technology, even for a process with a *known* nonlinearity, most FDI design methods lead to a situation with large probabilities of false alarms, simply due to the fact that they rely on linear methods and, hence, erroneously tend to detect the nonlinear effects as faults. Nonlinear FDI detectors has until recently only been considered in rather few papers only in spite of the tremendous problems caused by nonlinear phenomena. Nonlinearities in connection with FDI

has shortly been discussed in Reference [22] and in [26]. Lately, however, there has been increased interest in this issue, see e.g. References [27–33].

In Section 5 we will focus on direct estimation of the faults in the nonlinear case, and we shall try to demonstrate that this problem at least in principle has a simple remedy. This remedy provides a systematic design for nonlinear filters for nonlinear systems, but using only *linear* optimization techniques. The standing assumption will be that the process in consideration is described by a nonlinear model selected from a rich class of nonlinear dynamical systems subjected to general fault types, represented as exogenous signals.

2. SYSTEM SET-UP AND PROBLEM FORMULATION

A general system set-up is given in the following. The general set-up will be applied in the following sections in connection with fault diagnosis for systems with model uncertainty, fault diagnosis for systems with parametric uncertainty and fault diagnosis for nonlinear systems. Consider the set-up given in Figure 2, which is an extension of the set-up shown in Figure 1, but without a feedback controller included. The system G in Figure 2 has the following state space realization:

$$\begin{pmatrix} \dot{x} \\ z \\ y \end{pmatrix} = \begin{pmatrix} A & B_w & B_v & B_f & B_u \\ \hline C_z & D_{zw} & D_{zv} & D_{zf} & D_{zu} \\ C_y & D_{yw} & D_{yv} & D_{yf} & D_{yu} \end{pmatrix} \begin{pmatrix} x \\ w \\ v \\ f \\ u \end{pmatrix} \quad (1)$$

or let the system G be given as transfer functions

$$\begin{pmatrix} z \\ y \end{pmatrix} = \begin{pmatrix} G_{zw} & G_{zv} & G_{zf} & G_{zu} \\ G_{yw} & G_{yv} & G_{yf} & G_{yu} \end{pmatrix} \begin{pmatrix} w \\ v \\ f \\ u \end{pmatrix} \quad (2)$$

$x \in \mathcal{R}^n$ is the state vector, $z \in \mathcal{R}^q$ and $y \in \mathcal{R}^m$ are the external output signal and the measurement output signal, respectively. The inputs are external input $w \in \mathcal{R}^r$ from the uncertain block Δ , disturbance input $v \in \mathcal{R}^s$, fault input signal $f \in \mathcal{R}^k$ and the control input signal $u \in \mathcal{R}^p$, respectively. Further, it is assumed that all other relevant weight matrices are included in G . The connection between the external output z and the external input w is given by

$$w = \Delta z$$

The general system set-up given above in (1) describe a large class of different fault estimations problems. The different cases depend on the Δ block in Figure 2. The system set-up for the three different cases in this paper is now described.

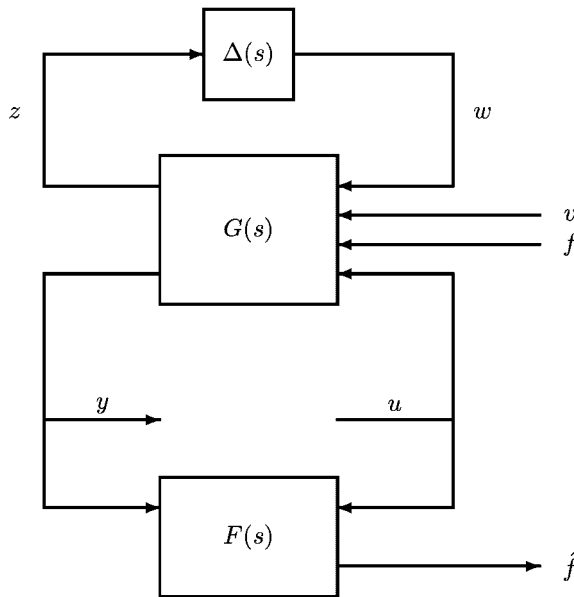

Figure 2. General set-up for robust fault detection in open loop.

2.1. Systems with model uncertainty

Model uncertainty is directly included in the system set-up given above. In connection with fault estimation (diagnosis) for systems including model uncertainty, it will be assumed that the perturbation block Δ is scaled such that

$$\|\Delta\| \leq 1, \quad \forall \omega$$

and the scaling function is included in G . There is no assumption about the structure of Δ .

2.2. Systems with parametric uncertainty/faults

Now, let us consider the case where the system include parametric faults (parametric uncertainties).

Let the general system in (1) be given by

$$\begin{pmatrix} \dot{x} \\ y \end{pmatrix} = \left(\begin{array}{c|cc} A_\Delta & B_v & B_u \\ \hline C_y & D_{yv} & D_{yu} \end{array} \right) \begin{pmatrix} x \\ v \\ u \end{pmatrix} \tag{3}$$

Note that the additive fault f is not included in this set-up for simplicity. However, including the additive fault in the set-up is definitely possible and not highly complicated.

A_Δ is a matrix that may deviate from a nominal value A_0 , by a (possibly nonlinear) dependency of a fault.

Hence, in this setting we do not allow directly for faults manifesting themselves in the input and/or output matrices (B_u/C_y) matrices which might be relevant in practice, e.g. in connection with gain variations. However, it is quite easy to model such faults as well in the set-up given by (3). The trick is to introduce an input filter, for instance of the form $1/(\tau s + 1)$ with τ sufficiently small, and associate the fault with the fictitious state introduced in this way.

The next step in the modelling procedure is to approximate the possibly nonlinear parameter dependencies of A_Δ with polynomial (in full generality: multinomial) or rational ones. Here, the following considerations must be taken:

- rational approximations of a specified order are usually better than polynomial approximations of the same order
- polynomial approximations of a specified order give better numerical results than rational approximations of the same order in the algorithm given in this section.

In conclusion, at least for small or medium variations, polynomial approximations will give better results than rational ones, but either can be considered for any application. To obtain a polynomial approximation, the obvious approach is to compute a multivariate Taylor series. For rational approximation the number of methods are legio. (For example, the function $\sin(\delta)$, $-1 < \delta < 1$ is approximated very well by the rational function $f_2(\delta) = \delta/(1 + 0.185\delta^2)$ but equally well by the polynomial function $f_1(\delta) = \delta - \frac{1}{6}\delta^3 + \frac{1}{120}\delta^5$). We are now faced with a model of the form (3) where A_Δ takes the form:

$$A_\Delta = A_0 + \sum_i f_i(\delta_1, \dots, \delta_p) A_i \quad (4)$$

where each f_i are polynomial or rational functions of the parameters $\delta_1, \dots, \delta_p$, satisfying

$$f_i(0, \dots, 0) = 0$$

(the non-faulty operation mode). Typically, each A_i will have only entries with values 0 and 1.

The third step in the problem set-up is to rewrite the model (4) as a linear fractional transformation. A general procedure to achieve this is described in [1, Section 10.2]. As a result we get a system of the form:

$$\begin{pmatrix} \dot{x} \\ z_p \\ y \end{pmatrix} = \left(\begin{array}{c|ccc} A & B_f & B_v & B_u \\ \hline C_f & 0 & 0 & 0 \\ C_y & 0 & D_{yv} & D_{yu} \end{array} \right) \begin{pmatrix} x \\ f_p \\ v \\ u \end{pmatrix} \quad (5)$$

where

$$f_p = \Delta_{\text{par}} z_p$$

and

$$\Delta_{\text{par}} = \begin{pmatrix} \delta_1 I_1 & 0 & 0 \\ 0 & \ddots & 0 \\ 0 & 0 & \delta_p I_p \end{pmatrix}$$

where the I_i 's are identity matrices. The dimension of each identity matrix depends on the order of the corresponding parameter δ_i in the polynomial or rational approximation. The matrix A will in general differ from A_0 , but will be of the same dimension. Without loss of generality, the model (4) can be assumed to be normalized such that each parameter δ_i varies between -1 and 1 .

This general representation of a system with parametric faults is depicted in Figure 3.

2.3. Nonlinear systems

Fault diagnosis for systems including nonlinear dynamics are now described. Before the system set-up is given, it should be pointed out that we shall not, for simplicity, include disturbances or model uncertainty, and fault models are only included implicitly. However, we would like to emphasize that these inclusions are straightforward extensions which can be handled by the very same optimization methods, all based again on the standard problem paradigm of robust control. The application of these techniques has been documented independently in a recent series of papers, see e.g. Reference [21] and the references therein. We shall consider a general class of nonlinear systems as depicted in Figure 4. The block diagram in Figure 4 is a special case of the block diagram in Figure 2, without the disturbance input signal v , the control input signal u , and where Δ is a nonlinear block.

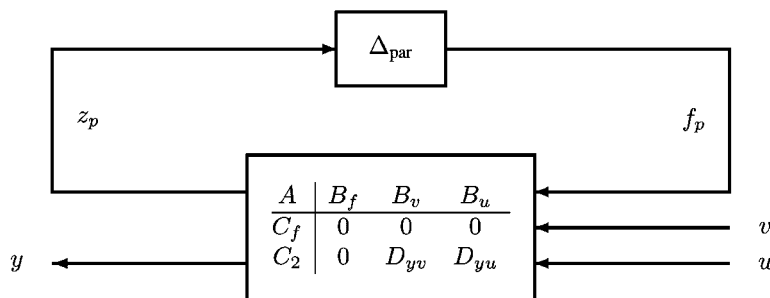

Figure 3. Formulation of a system with parametric faults as a linear fractional transformation in the fault parameters Δ_{par} .

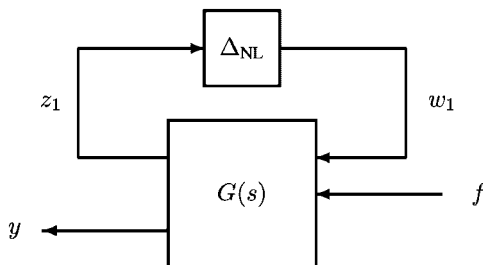

Figure 4. A class of nonlinear systems subjected to faults.

In Figure 4, $G(s)$ is a linear system with two sets of (vector) inputs: w_1 and f , and Δ_{NL} represents a nonlinear—possibly dynamical—mapping. The exogenous signal f is the vector of faults to be detected and isolated by the FDI system. It is of significant importance, although not explicitly expressed in this section, to formulate a dynamical model for the anticipated faults. In Figure 4 this dynamical model has been incorporated in $G(s)$.

The interconnection of $G(s)$ and the Δ_{NL} block represents a full nonlinear model of the dynamical process, for which we wish to design a FDI system. Usually, $G(s)$ should be thought of as the linearization of the process in some operating point.

2.4. Fault estimation problem

Based on the three set-ups given above, fault estimations problems are now formulated. The design problem is formulated as a standard optimization problem. Let the estimation error e defined by

$$e = f - \hat{f} \quad (6)$$

where \hat{f} is given by

$$\hat{f} = F(s)y$$

or by

$$\hat{f} = F(s)y - F(s)G_{yu}u$$

when the control input signal is included in the set-up. The design problem is to design the residual generator such that the estimation error e is minimized in some sense.

It should be pointed out that the standard set-up applied in this paper can also be applied in connection with fault detection as well as fault isolation. The estimation error given by (6) is then given by

$$e = V(s)f - r$$

where $V(s)$ is a weight matrix and the residual vector given by $r = F(s)y$ or by $r = F(s)y - F(s)G_{yu}u$ when the control input signal is included in the set-up. In the fault detection case as well as in the fault isolation case, V need to satisfy a rank condition but else free to select. In an optimization of a residual generator using the standard set-up, V need to be optimized simultaneously with the residual generator, which complicate the optimization. A method for doing this optimization has been described in References [34,35].

3. FDI FOR SYSTEMS WITH MODEL UNCERTAINTY

An analysis of fault estimation (fault diagnosis) for systems including uncertainty will be in this section. The main analysis results will be given here for both nominal systems as well as for uncertain systems in open and closed loop set-up. Based on the general case, a special case is shortly considered.

3.1. General case

Consider the system given by (2). Let the loop from z to w is closed by the uncertain block Δ , $w = \Delta z$, the open loop system in (2) takes the following form:

$$\begin{aligned}
 y &= (G_{yw}\Delta S_{\Delta}G_{yw} + G_{yv}G_{yw}\Delta S_{\Delta}G_{yf} + G_{yf}G_{yw}\Delta S_{\Delta}G_{yu} + G_{yu}) \begin{pmatrix} v \\ f \\ u \end{pmatrix} \\
 &= (\bar{G}_{yv} \ \bar{G}_{yf} \ \bar{G}_{yu}) \begin{pmatrix} v \\ f \\ u \end{pmatrix} \tag{7}
 \end{aligned}$$

where $S_{\Delta} = (I - G_{zw}\Delta)^{-1}$. Based on the equation for the output given by (7), we have the following result.

Theorem 1

Let the fault estimation error be given by (6). The fault estimation error for the uncertain system in (7) in open loop is then given by

$$\begin{aligned}
 e_{\text{open}}(\Delta) &= (I - FG_{yw}\Delta S_{\Delta}G_{yf} - FG_{yf})f - (FG_{yw}\Delta S_{\Delta}G_{yv} + FG_{yv})v \\
 &\quad - FG_{yw}\Delta S_{\Delta}G_{yu}u
 \end{aligned}$$

The fault estimation error for the nominal system ($\Delta = 0$) in open loop is then given by

$$e_{\text{open}} = (I - FG_{yf})f - FG_{yv}v$$

With the perturbation block present in the system, three additional terms appear in the equation for the estimation error, compared to the nominal case. Further, it turns out from the nominal case that it is not possible to make estimation of f if the disturbance v is in the same frequency range as the fault signal f is and has the same direction at the system. There is a trade-off between fault detection and disturbance attenuation. This trade-off exist also in the uncertain case together with the uncertainty Δ which make the fault estimation more difficult. Now, consider the closed loop uncertain system. The control input signal u is given by

$$u = K(s)y \tag{8}$$

where $K(s)$ is a stabilizing feedback controller. Closing the loop in (7) with a feedback controller $K(s)$, we get the following result.

Theorem 2

Let the fault estimation error be given by (6). The fault estimation error for the uncertain system in (7) in closed loop is then given by

$$e_{\text{closed}}(\Delta) = (I - F(I - \bar{G}_{yu}K)^{-1}\bar{G}_{yf})f - F(I - \bar{G}_{yu}K)^{-1}\bar{G}_{yv}v$$

The fault estimation error for the nominal system ($\Delta = 0$) in closed loop is then given by

$$e_{\text{closed}} = (I - FSG_{yf})f - FSG_{yv}v$$

where S is an output sensitivity function.

From the above, we can see that the only difference between the estimation error for the open loop given in Theorem 1 and for the closed loop given in Theorem 2, in the nominal case is that the sensitivity function S is included. So, if the filter is selected as $F_{\text{closed}} = F_{\text{open}}S^{-1}$, we get exactly the same equation for the estimation error as in the open loop case. Hence, we can conclude that the open loop and the closed loop cases are equivalent in the nominal case as it was shown in more detail in [12]. Due to the uncertain block Δ , the open loop and the closed loop estimation error is not so directly related as in the nominal case.

3.2. A special case

A special case of the more general case considered in Section 3.1 will be considered here. Let us consider a system given by

$$y = G(s)(I + \Delta)(f + v + u) \quad (9)$$

where Δ is a multiplicative perturbation at the plant input. Using the same formulation as in Section 3.1, the system in (9) is given by

$$\begin{pmatrix} z \\ y \end{pmatrix} = \begin{pmatrix} 0 & I & I & I \\ G & G & G & G \end{pmatrix} \begin{pmatrix} w \\ v \\ f \\ u \end{pmatrix} \quad (10)$$

Note that both the fault signal f , the disturbance signal v and the control input signal u enter the system at the same place. If there is not a separation in frequency between the fault signal and the disturbance input signal, it will not be possible to separate the fault signal from the disturbance signal. Without loss of generality, it will in the following be assumed that there is no disturbance input signal, i.e. $v = 0$. Using Theorems 1 and 2, we get directly the following lemma.

Lemma 3

The fault estimation error e for the uncertain system in (9) is given by

$$e_{\text{open}}(\Delta) = (I - FG(I + \Delta))f - F\Delta u$$

for the open loop case and

$$e_{\text{closed}}(\Delta) = (I - FSG(I - \Delta T)^{-1}(I + \Delta))f$$

for the closed-loop case, respectively, where $T = GK(I - GK)^{-1}$ is the complementary sensitivity function. The nominal fault estimation errors are given by

$$e_{\text{open}} = (I - FG)f$$

and

$$e_{\text{closed}} = (I - FSG)f$$

for open loop and closed loop, respectively.

Note that the fault estimation error for both open loop as well as for closed loop in the uncertain case, can be written as the fault estimation error for the nominal case and an additional term as function for the uncertain block. For the closed loop case, the fault

estimation error can be written as

$$\begin{aligned}
 e_{\text{closed}}(\Delta) &= e_{\text{nom}} + e_{\text{closed,unc}}(\Delta) \\
 &= (I - FSG)f - FSG\Delta f - FSG\Delta T_l(I - \Delta T_l)^{-1}(I + \Delta)f
 \end{aligned}
 \tag{11}$$

Now, consider the case where the feedback controller is designed with 50% robustness margin, i.e. $|\Delta T_l| \simeq 0.5$. Then $|\Delta T_l(I - \Delta T_l)^{-1}| \simeq 1$. The estimation error from (11) is then given by

$$e_{\text{closed}}(\Delta) \simeq (I - 2FSG)f - 2FSG\Delta f
 \tag{12}$$

As a consequence of (12), we can see that even if the uncertainty is small, a quite large estimation error is obtained due to the term $FSGf$. If the nominal estimation error e_{nom} is small, i.e. $|e_{\text{nom}}| \ll 1$, we will have that $FSG \simeq 1$ in the frequency range where we want to make fault estimation. Using this approximation, (12) is then given by

$$e_{\text{closed}}(\Delta) \simeq -(I + 2\Delta)f
 \tag{13}$$

in a certain frequency range. Eq. (13) shows that we get more than 100% estimation error in the case where the feedback controller is designed with 50% robustness margin. This result is in accordance with the results from Reference [19], where it is shown that it is not possible to separate control and fault detection in the uncertain case when a compact set-up is applied. The results here give an indication of how the estimation error will increase when a separated design of the controller and the fault detection filter is applied.

At first glance it seems a little strange that we get a worse estimation error when we applied the information of how the control input signal is derived. The reason is that we in practice decrease the information available for the fault estimation. In the open-loop case we use the control input signal directly, where as the control input signal is only used indirectly in the closed-loop case. As a matter of fact, when we use the open-loop formulation, the uncertainty will not be fed back, because we use the real signal. Hence, we have more information available in the open-loop case which makes the difference. The analysis of the closed-loop case above shows what can happen when this information cannot be used.

4. FDI FOR SYSTEMS WITH PARAMETRIC FAULTS

4.1. Problem formulation

The approach taken is to model a potentially faulty component as a nominal component in parallel with a (fictitious) error component. The optimization procedure suggested in this section then tries to estimate the in- and outgoing signals from the error component. This works of course only well in cases where the component is reasonably well excited, but on the other hand, if the component is not active at all, there is absolutely no way to detect whether it is faulty, in theory or practice!

In Section 2.2 a model was derived from the ‘physical’ parameter varying model having the form:

$$\begin{pmatrix} \dot{x} \\ z_p \\ y \end{pmatrix} = \left(\begin{array}{c|ccc} A & B_f & B_v & B_u \\ \hline C_f & 0 & 0 & 0 \\ C_y & 0 & D_{yv} & D_{yu} \end{array} \right) \begin{pmatrix} x \\ f_p \\ v \\ u \end{pmatrix} \quad (14)$$

where

$$f_p = \Delta_{\text{par}} z_p$$

was a vector of output signals from the error components, and

$$\Delta_{\text{par}} = \begin{pmatrix} \delta_1 I_1 & 0 & 0 \\ 0 & \ddots & 0 \\ 0 & 0 & \delta_p I_p \end{pmatrix}$$

was a matrix, containing in its diagonal the values of the parameter deviations.

The next step in setting up the fault estimation problem as a standard optimization problem is to introduce two fault estimation errors e_f and e_z as

$$e_f = f_p - \hat{f}_p \quad \text{and} \quad e_z = z_p - \hat{z}_p \quad (15)$$

where \hat{f}_p and \hat{z}_p are the estimates of f_p and z_p , respectively, to be generated. The rationale for estimating both is, that on top of designing a supervisory system that reacts on a threshold value of either variable, forming the ratio of the norms of these two signals provides an estimate of the parameter values themselves.

Combining (14), (15), and the identity $u \equiv u$, the standard model becomes:

$$\begin{pmatrix} \dot{x} \\ z_p \\ e_f \\ e_z \\ u \\ y \end{pmatrix} = \left(\begin{array}{c|cccc|cc} A & B_f & B_v & B_u & 0 & 0 \\ \hline C_f & 0 & 0 & 0 & 0 & 0 \\ 0 & I & 0 & 0 & -I & 0 \\ C_f & 0 & 0 & 0 & 0 & -I \\ \hline 0 & 0 & 0 & I & 0 & 0 \\ C_y & 0 & D_{yv} & D_{yu} & 0 & 0 \end{array} \right) \begin{pmatrix} x \\ f_p \\ v \\ u \\ \hat{f}_p \\ \hat{z}_p \end{pmatrix} \quad (16)$$

The signals and interconnection structure defined in this way is depicted in Figure 5.

In order to design a filter F such that applying F to u and y :

$$\begin{pmatrix} \hat{f}_p \\ \hat{z}_p \end{pmatrix} = F \begin{pmatrix} u \\ y \end{pmatrix}$$

provides the two desired estimates \hat{f}_p and \hat{z}_p , one additional step is required, which is the introduction of a fictitious performance block Δ_{perf} , suggesting that the inputs $\begin{pmatrix} u \\ y \end{pmatrix}$ were generated

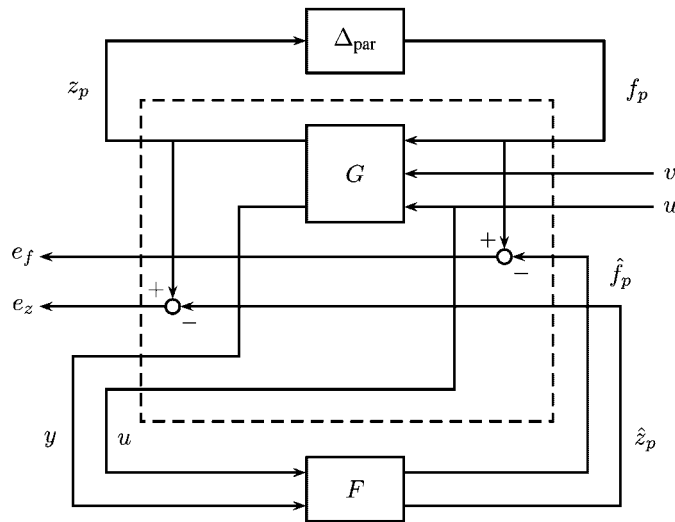

Figure 5. Standard problem set-up for parametric fault detection.

as a feedback Δ_{perf} from the outputs (e_f) :

$$\begin{pmatrix} v \\ u \end{pmatrix} = \Delta_{\text{perf}} \begin{pmatrix} e_f \\ e_z \end{pmatrix}$$

Finally, we introduce

$$\Delta = \begin{pmatrix} \Delta_{\text{par}} & 0 \\ 0 & \Delta_{\text{perf}} \end{pmatrix}$$

Introducing Δ_{perf} in Figure 5 and extracting the Δ block from the diagram, gives Figure 6 which shows the final standard problem formulation.

The significance of the Δ_{perf} block is the following. According to the small gain theorem, the \mathcal{H}_∞ norm of the transfer function from (v) to (e_f) is bounded by γ if and only if the system in Figure 5 is stable for all $\Delta_{\text{perf}}, \|\Delta_{\text{perf}}\|_\infty < \gamma$. Hence, the problem of making the norm of the fault estimation error bounded by some quantity has been transformed to a stability problem. We shall give more details on this issue in the following section.

Usually, filtered versions of e_w and e_z will be used in a practical optimization. This is easily done by introducing some auxiliary states in the model. Provided the \mathcal{H}_∞ norm from (v) to (e_z) is sufficiently small, the ratio $\|\hat{w}_f\|/\|\hat{z}_f\|$ is a good approximation for Δ_{par} .

4.2. Main results for FDI problems with parametric faults

The main result is:

Theorem 4

Let $F(s)$ be a linear filter applied to the system (16) as $(\hat{z}_p) = F(y)$, and assume that $F(s)$ satisfies:

$$\|\mathcal{F}_\ell(G_{z\hat{w}}, F)\|_\mu < \gamma$$

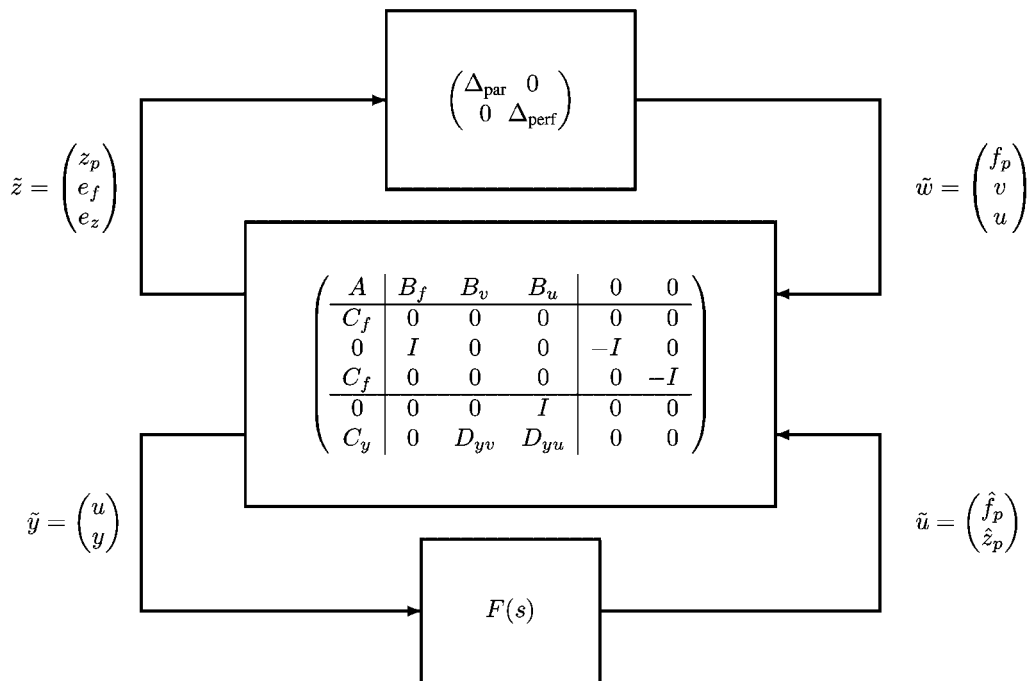

Figure 6. Standard problem formulation. The middle block is the same as the one indicated by the dashed box in Figure 5.

then the resulting fault estimation error is bounded by

$$\left\| \begin{pmatrix} e_f \\ e_z \end{pmatrix} \right\| < \gamma N$$

where N is the excitation level of the system, i.e. $\|C_y^v\| = N$.

In the following we shall present a synthesis procedure for $F(s)$. A number of different more or less complicated synthesis methods can be applied on the above design problem given in Theorem 4. The main problem with the above design problem is that the perturbation block Δ consists of both real and complex perturbations. The standard μ synthesis method [1], cannot in general be applied without introducing conservatism in the design. The reason is that the standard μ synthesis method can only handle complex perturbations. A number of alternative synthesis methods for mixed perturbations has been considered in Reference [36] in connection with design of a missile autopilot.

Indeed, it is possible to apply the standard μ synthesis, if an additional scaling matrix is introduced in the method. This extra scaling matrix takes into account the difference between the mixed and the complex μ . In the following, the complex μ and the modified μ synthesis methods are shortly described.

4.3. μ Synthesis

We may now formulate an optimal robust performance problem in terms of μ :

$$F(s) = \arg \min_{F(s) \in \mathbf{F}} \|\mu_{\Delta}(\mathcal{F}_l(\tilde{G}(s), F(s)))\|_{\infty} \tag{17}$$

where \mathbf{F} denotes the set of all nominally stabilizing controllers (there might not exist an admissible controller achieving the minimum, but we make this abuse of notation for convenience). \tilde{G} is the system, see Figure 6. Unfortunately (17) is not tractable since μ cannot be directly computed. Rather the upper bound β_{\min} is used to formulate the control problem:

$$F(s) = \arg \min_{F \in \mathbf{F}} \sup_{\omega} \inf_{D(\omega) \in \mathbf{D}, G(\omega) \in \mathbf{G}} \inf_{\beta(\omega) \in \mathcal{R}_+} \{\beta(\omega) | \bar{\sigma}(\Sigma(\omega)) \leq 1\} \tag{18}$$

where

$$\Sigma(\omega) = \left(\frac{D(\omega) \mathcal{F}_l(\tilde{G}(j\omega), F(j\omega)) D^{-1}(\omega)}{\beta(\omega)} - jG(\omega) \right) (I + G^2(\omega))^{-1/2}$$

where

$$\mathbf{D} = \{\text{diag}(D_1, \dots, D_p, dI_{\text{perf}}) | D_i \in \mathcal{C}^{k_i \times k_i}, D_i^* = D_i > 0, d \in \mathcal{R}, d > 0\}$$

$$\mathbf{G} = \{\text{diag}(G_1, \dots, G_p, O) | G_i \in \mathcal{C}^{k_i \times k_i}, G_i = G_i^*\}$$

The structure of \mathbf{D} and \mathbf{G} depend on the structure of the perturbation block Δ .

For purely complex perturbations, the control problem reduce to

$$F(s) = \arg \min_{F \in \mathbf{F}} \sup_{\omega} \inf_{D \in \mathbf{D}} \{\bar{\sigma}(D(\omega) \mathcal{F}_l(\tilde{G}(j\omega), F(j\omega)) D^{-1}(\omega))\} \tag{19}$$

The control problems (18) and (19) are both *scaled \mathcal{H}_{∞} optimization problems*. Scaled \mathcal{H}_{∞} optimizations have recently been an area of intensive research within the automatic control community. However, no solution to (18) or (19) has yet been found. Rather iterative approximate solution procedures have been developed for both purely complex and mixed perturbation sets.

4.4. Complex μ synthesis

An approximation to complex μ synthesis can be made by the following iterative scheme. For a fixed controller $F(s)$, the problem of finding $D(\omega)$ at a set of chosen frequency points ω is just the complex μ upper bound problem which is a convex problem with known solution. Having found these scalings we may fit a real rational stable minimum phase transfer function matrix $D(s)$ to $D(\omega)$ by fitting each element of $D(\omega)$ with a real rational stable minimum phase SISO transfer function. We may impose the extra constraint that the approximations $D(s)$ should be minimum phase (so that $D^{-1}(s)$ is stable too) since any phase in $D(s)$ is absorbed into the complex perturbations. For a given magnitude of $D(\omega)$, the phase corresponding to a minimum phase transfer function system may be computed using complex cepstrum techniques. Accurate transfer function estimates may then be generated using standard frequency domain least squares techniques.

For given scalings $D(s)$, the problem of finding a controller (in our case a filter) $F(s)$ which minimizes the norm $\|\mathcal{F}_l(D(s)\tilde{G}(s)D^{-1}(s), F(s))\|_{\mathcal{H}_{\infty}}$ will be reduced to a standard \mathcal{H}_{∞} problem. Repeating this procedure several times will yield the complex μ upper bound optimal controller

provided the algorithm converges. Even though the computation of the D scalings and the optimal \mathcal{H}_∞ controller are both convex problems, the iteration procedure is *not jointly convex* in $D(s)$ and $F(s)$ and counter examples of convergence has been given [37]. However, the iteration seems to work quite well in practice and has been successfully applied to a large number of applications. Furthermore, with the release of the MATLAB μ -Analysis and Synthesis Toolbox, commercially available software now exists to support complex μ synthesis using this iteration.

4.5. Mixed μ synthesis

A detailed description of the mixed μ synthesis method described in the following can be found in References [38,39].

The main idea of the proposed mixed μ iteration scheme is to perform a scaled complex μ synthesis where the difference between mixed and complex μ is taken into account through an additional scaling matrix $\Gamma(s)$. Given the augmented system $\tilde{G}(s)$, a stabilizing controller $F_1(s)$ (e.g. an \mathcal{H}_∞ optimal controller) we may compute upper bounds for μ across frequency given both the ‘true’ mixed perturbation set Δ and the fully complex approximation Δ^c , i.e. δ_i are considered as a complex parameter. In order to ‘trick’ the \mathcal{H}_∞ optimization in the next iteration to concentrate more on mixed μ , we will construct an open-loop system $\tilde{G}_{D\Gamma}(s)$ which, when closed with the previous controller, has frequency response equal to the mixed μ upper bound just computed. In the mixed μ iteration, however, the structure of the approximation is different. $\tilde{G}_{D\Gamma} = \Gamma D \tilde{G} D^{-1}$ is constructed by applying two scalings to the original system $\tilde{G}(s)$. A D scaling such that $\bar{\sigma}(\mathcal{F}_\ell(D\tilde{G}D^{-1}, F))$ approximates the complex μ upper bound and a Γ scaling to shift from complex to mixed μ . In each iteration, Γ can be computed as

$$\Gamma_i(s) = \begin{bmatrix} \gamma_i(s)I_{n_{ze}} & 0 \\ 0 & I_{n_y} \end{bmatrix}$$

where

$$\gamma_i(j\omega) = (1 - \alpha_i)|\gamma_{i-1}(j\omega)| + \alpha_i \frac{\hat{\mu}_\Delta(\mathcal{F}_\ell(\tilde{G}(j\omega), F_i(j\omega)))}{\hat{\mu}_{\Delta^c}(\mathcal{F}_\ell(\tilde{G}(j\omega), F_i(j\omega)))}$$

α_i is a certain filtering variable, see below, n_{ze} denotes the number of measurement outputs and n_y denotes the number of external outputs. For perfect realizations of the scalings we will have

$$\bar{\sigma}(\mathcal{F}_\ell(\tilde{G}_{D\Gamma}(j\omega), F_1(j\omega))) = \hat{\mu}_\Delta(\mathcal{F}_\ell(\tilde{G}(j\omega), F_1(j\omega)))$$

where $\hat{\mu}_\Delta$ denoted the upper bound for μ . The controller $F_2(s)$ then will minimize the \mathcal{H}_∞ -norm of an augmented system which closed with the previous controller $F_1(s)$ has maximum singular value approximating mixed μ . New mixed and complex μ bounds may then be computed and the procedure may be repeated.

Applications of the mixed μ method can be found in References [38–40]. It is shown that the above mixed μ synthesis method are more optimal than the direct mixed μ synthesis method described in Reference [41].

4.6. A combined FDI set-up

As mentioned above, parametric faults in actuator and sensor dynamics can easily be modelled in the approach of this section by a simple trick. However, the additive fault description is the

most used approach, see e.g. References [19,26,42]. A system set-up for parametric and additive faults will shortly be considered in the following.

Including additive faults in the model described in Section 2.2 gives the following system:

$$\begin{pmatrix} \dot{x} \\ y \end{pmatrix} = \left(\begin{array}{c|ccc} A_\Delta & B_{f_a} & B_v & B_u \\ \hline C_y & D_{yf_a} & D_{yv} & D_{yu} \end{array} \right) \begin{pmatrix} x \\ f_a \\ v \\ u \end{pmatrix} \quad (20)$$

where f_a is the additive fault input vector.

For obtaining a standard optimization problem, the estimation error e_a is introduced as, in the the parametric fault case:

$$e_a = f_a - \hat{f}_a \quad (21)$$

where \hat{f}_a is the estimate of f_a , that need to be generated by $\hat{f}_a = F(s)y$.

Combining the model for the parametric fault case given by (16) with the estimation error for the additive faults given by (21) gives a set-up where the design synthesis given in Section 4.2 can be applied directly to the above system.

5. FDI FOR A CLASS OF NONLINEAR SYSTEMS

5.1. Problem formulation

In the internal model control (IMC) approach to nonlinear systems, the underlying idea is to copy any nonlinear dynamics in the observer. We shall generalize this concept in terms of the fault detection architecture shown in Figure 7, although the suggested approach will not be observer based. A similar architecture was used for gain scheduling purposes in Reference [43] and for control of time varying systems in Reference [44].

In Figure 7, the interconnection of $F(s)$ and the lower Δ_{NL} block represents the FDI system to be designed. $F(s)$ is a free linear parameter to be synthesized, whereas Δ_{NL} is simply a copy of the (known) nonlinear dynamics of the process.

The signal \hat{f} is the estimate of f generated by the FDI system. By using the general set-up shown in Figure 7, it is possible to handle both actuator faults, sensor faults and internal fault signals, see e.g. Reference [38].

The signal w_2 represents the response to the test signal z_2 generated by the linear part of the FDI system, $F(s)$. Hence, in analogy, in nonlinear IMC control, w_2 would be an estimate of w_1 based on the estimate z_2 of the internal signal z_1 .

The nonlinearity Δ_{NL} in this setting will be assumed to be sector bounded in an \mathcal{H}_∞ sense. To be more precise, we shall employ a stability argument below. The crucial assumption is then that by absorbing dynamical weights, $G(s)$ can be designed such that it is possible to infer stability of the nonlinear loop with some specific Δ_{NL} from robust stability w.r.t. the \mathcal{H}_∞ unit ball. It is quite easy to describe a nonlinearity for which this is not possible *globally*, but in practice the assumption will usually hold, at least in some reasonable neighbourhood of the linearization $G(s)$.

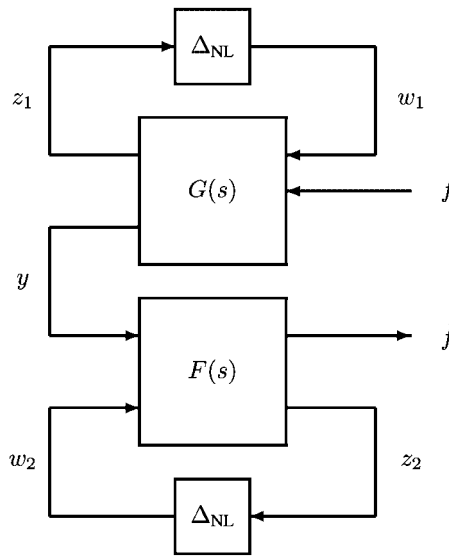

Figure 7. Fault detection for a nonlinear system.

In the following we shall describe a synthesis procedure for the linear part $F(s)$ of the FDI system.

5.2. A standard problem approach for nonlinear FDI problems

In this section we shall first rewrite the isolation problem as a decoupling problem, and then, subsequently, transform this decoupling problem into an equivalent stability problem.

First, as in standard observer approaches, we consider the fault estimates rather than the estimates themselves:

$$e(t) = f(t) - \hat{f}(t)$$

Hence, the problem now has been transformed to make $e(t)$ small for any (bounded) $f(t)$ or, equivalently, to bound the (nonlinear) operator gain from f to e , which we shall take to mean the \mathcal{L}_2 - \mathcal{L}_2 gain. Without loss of generality (by absorbing scalings in the $G(s)$ part) we can assume that the required \mathcal{L}_2 - \mathcal{L}_2 gain is unity. The next step is to transform the \mathcal{L}_2 - \mathcal{L}_2 gain requirement to a stability requirement. Sufficiency for this is readily obtained through a small gain argument, by employing the above assumption.

Indeed, in Figure 8 the \mathcal{L}_2 - \mathcal{L}_2 gain from f to e is inferred to be bounded by one if robust stability holds for the system augmented with the Δ_P block inserted, for all $\Delta_P \in \mathcal{H}_\infty$, $\|\Delta_P\|_\infty < 1$.

The final step now is to reformulate the set-up depicted in Figure 8 into a standard problem formulation (see e.g. Reference [1] for a description of the standard problem). The result is shown in Figure 9.

In Figure 9, stability subject to any *linear* operator valued entries of Δ_{NL} , $\|\Delta_{NL}\|_\infty < 1$, and of Δ_P , $\|\Delta_P\|_\infty < 1$ implies the normalized nonlinear operator gain from fault vector f to fault estimation error

$$e = f - \hat{f}$$

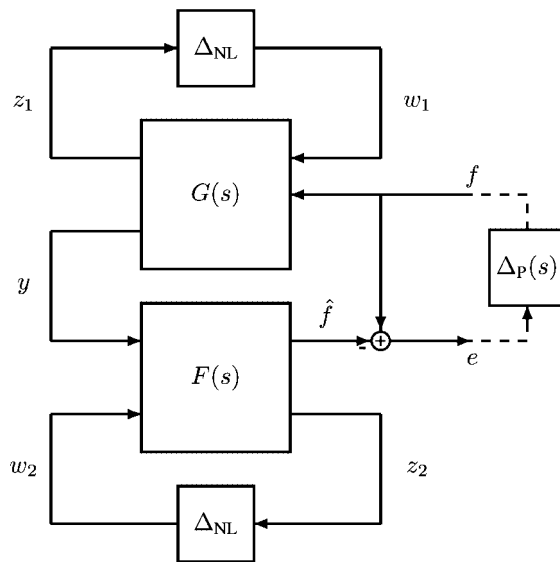

Figure 8. Introduction of a performance block.

to be bounded by unity. This follows from a small gain argument along with the assumption of the nonlinearity.

The relationship between $\tilde{G}(s)$ in Figure 9 and $G(s)$ in Figure 8 is given by

$$\begin{pmatrix} z_1 \\ z_2 \\ e \\ y \\ w_2 \end{pmatrix} = \tilde{G}(s) \begin{pmatrix} w_1 \\ w_2 \\ f \\ \hat{f} \\ z_2 \end{pmatrix}$$

$$= \left(\begin{array}{ccc|cc} (I \ 0)G(s) \begin{pmatrix} I & 0 & 0 \\ 0 & 0 & I \end{pmatrix} & 0 & 0 & & \\ & 0 & 0 & 0 & I \\ & 0 & 0 & -I & 0 \\ \hline (0 \ I)G(s) \begin{pmatrix} I & 0 & 0 \\ 0 & 0 & I \end{pmatrix} & 0 & 0 & & \\ & 0 & I & 0 & 0 \end{array} \right) \begin{pmatrix} w_1 \\ w_2 \\ f \\ \hat{f} \\ z_2 \end{pmatrix}$$

or

$$\begin{pmatrix} \tilde{z} \\ \tilde{y} \end{pmatrix} = \tilde{G}(s) \begin{pmatrix} \tilde{w} \\ \tilde{u} \end{pmatrix}$$

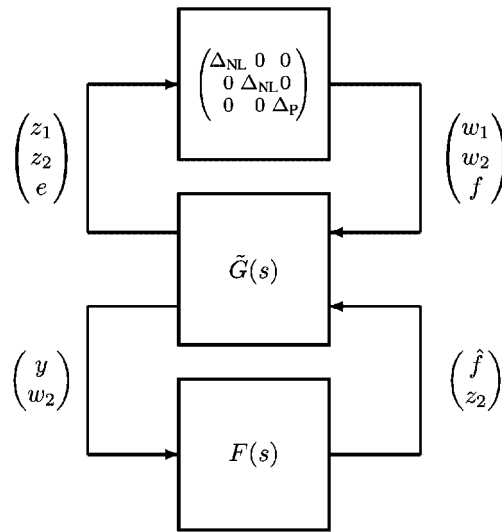

Figure 9. Standard problem formulation.

which means that

$$\tilde{G}(s) = \left(\begin{array}{ccc|cc} 0 & 0 & 0 & 0 & 0 \\ 0 & 0 & 0 & 0 & I \\ 0 & 0 & I & -I & 0 \\ \hline 0 & 0 & 0 & 0 & 0 \\ 0 & I & 0 & 0 & 0 \end{array} \right) + \left(\begin{array}{cc} I & 0 \\ 0 & 0 \\ 0 & 0 \\ 0 & I \\ 0 & 0 \end{array} \right) G(s) \left(\begin{array}{ccc|cc} I & 0 & 0 & 0 & 0 \\ 0 & 0 & I & 0 & 0 \end{array} \right) \quad (22)$$

or

$$\begin{aligned} \tilde{G}(s) &= \begin{pmatrix} \tilde{G}_{z\tilde{w}}(s) & \tilde{G}_{z\tilde{u}}(s) \\ \tilde{G}_{y\tilde{w}}(s) & \tilde{G}_{y\tilde{u}}(s) \end{pmatrix} \\ &= \left(\begin{array}{ccc|cc} G_{z_1 w_1}(s) & 0 & G_{z_1 f}(s) & 0 & 0 \\ 0 & 0 & 0 & 0 & I \\ 0 & 0 & I & -I & 0 \\ \hline G_{y w_1}(s) & 0 & G_{y f}(s) & 0 & 0 \\ 0 & I & 0 & 0 & 0 \end{array} \right) \end{aligned}$$

where

$$G(s) = \begin{pmatrix} G_{z_1 w_1}(s) & G_{z_1 f}(s) \\ G_{y w_1}(s) & G_{y f}(s) \end{pmatrix}$$

In particular we note, that if the state space representation of $G(s)$:

$$\begin{pmatrix} \dot{x} \\ z_1 \\ y \end{pmatrix} = \left(\begin{array}{c|cc} A & B_1 & B_2 \\ \hline C_1 & D_{11} & D_{12} \\ \hline C_2 & D_{21} & D_{22} \end{array} \right) \begin{pmatrix} x \\ w_1 \\ f \end{pmatrix}$$

is of order n , so is the state space representation of $\tilde{G}(s)$:

$$\begin{pmatrix} \dot{x} \\ z_1 \\ z_2 \\ e \\ y \\ w_2 \end{pmatrix} = \left(\begin{array}{c|ccc|cc} A & B_1 & 0 & B_2 & 0 & 0 \\ \hline C_1 & D_{11} & 0 & D_{12} & 0 & 0 \\ 0 & 0 & 0 & 0 & 0 & I \\ \hline 0 & 0 & 0 & I & -I & 0 \\ \hline C_2 & D_{21} & 0 & D_{22} & 0 & 0 \\ \hline 0 & 0 & I & 0 & 0 & 0 \end{array} \right) \begin{pmatrix} x \\ w_1 \\ w_2 \\ f \\ \hat{f} \\ z_2 \end{pmatrix}$$

which implies that the crucial optimization in the sequel will involve a system of the same order as the original system data.

5.3. Optimization

The desired filter $F(s)$ can be found directly by μ -optimization w.r.t. the following structure of the singular value:

$$\begin{pmatrix} \Delta_{NL} & 0 & 0 \\ 0 & \Delta_{NL} & 0 \\ 0 & 0 & \Delta_P \end{pmatrix} \tag{23}$$

i.e. with one repeated full complex block and with one non-repeated full complex block.

Our main result states that a nonlinear fault detection system can be computed by first finding a linear filter by solving a μ problem for a linear system structure.

The resulting filter solves the FDI problem according to the following result:

Theorem 5

Assume that the system

$$\tilde{G}(s) = \begin{pmatrix} \tilde{G}_{z\tilde{w}}(s) & \tilde{G}_{z\tilde{u}}(s) \\ \tilde{G}_{y\tilde{w}}(s) & \tilde{G}_{y\tilde{u}}(s) \end{pmatrix}$$

and the linear filter $F(s)$ satisfies

$$\|\tilde{G}_{z\tilde{w}}(\cdot) + \tilde{G}_{z\tilde{u}}(\cdot)F(\cdot)\tilde{G}_{y\tilde{w}}(\cdot)\|_{\mu} < \gamma \tag{24}$$

w.r.t. the uncertainty structure (23), then the \mathcal{L}_2 - \mathcal{L}_2 operator gain from fault f to fault estimation error

$$e = f - \hat{f}$$

when applying the FDI system:

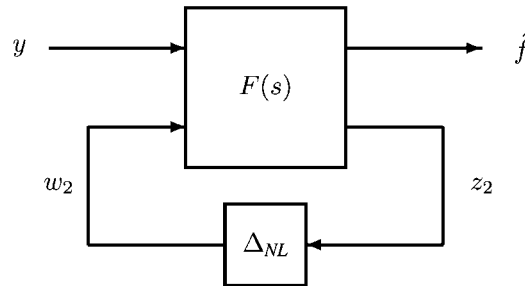

is bounded by γ as well.

A fault detection system based on Theorem 5 can be computed by the D-K algorithm. Although (24) is a model matching problem, the solution to this is obtained by applying standard D-K iterations to the system $\tilde{G}(s)$, since $\tilde{G}_{y\tilde{u}}$. Hence,

$$\tilde{G}_{z\tilde{w}}(\cdot) + \tilde{G}_{z\tilde{u}}(\cdot)F(\cdot)(I - \tilde{G}_{y\tilde{u}}(\cdot))^{-1}\tilde{G}_{y\tilde{w}}(\cdot) = \tilde{G}_{z\tilde{w}}(\cdot) + \tilde{G}_{z\tilde{u}}(\cdot)F(\cdot)\tilde{G}_{y\tilde{w}}(\cdot)$$

Alternatively, using multiplier theory, a solution based on linear matrix inequalities can be given, which is omitted here due to space limitations.

6. CONCLUSIONS

In this paper, three different classes of FDI problems have been addressed: FDI for uncertain systems; FDI for systems with parametric faults; and FDI for nonlinear systems.

In Section 3, fault detection in open loop vs. closed loop has been considered for both nominal systems as well as for uncertain systems. In the nominal case, there is in principle no difference between open loop and closed loop fault detection. This is not the case for uncertain systems. In this case, there is a trade-off between good fault detection and good performance of the closed loop system. The trade-off can be quantified by comparing optimization results of the combined system with optimization results of the two individual parts.

A systematic modelling and synthesis procedure for deriving fault detection and isolation filters for parametric faults has been presented in Section 4. Further, a combined set-up for fault detection and isolation in systems including both parametric as well as additive faults has been given.

The derived method includes a possibility for trading off the risk of undetected faults to the risk of false alarms.

The FDI set-up considered in Section 4 deals only with the nominal case. However, the synthesis procedure for deriving fault detectors can quite easily be extended to handle model uncertainties, i.e. robust fault detection and isolation. This can be done by including uncertainty blocks in the block that describes the parametric fault and the performance condition. Both real as well as complex uncertainties can be handled in the set-up. This section proposes a numerical solution based on a specific mixed μ optimization method. This is just one of many feasible solutions, however, and depending on the application and problem data, one might choose any

alternative optimization method, such as other algorithms for μ optimization, or altogether different approaches, such as multiplier methods based on LMI algorithms.

In Section 5 an optimization filter synthesis procedure has been proposed for design of a fault detection and isolation system for a class of nonlinear systems. The designed FDI system is nonlinear itself, where the nonlinearity—in similarity to the internal model control approach to nonlinear systems—is copied from the (known) nonlinearity in the process itself, although the suggested FDI system architecture is not explicitly observer based.

In spite of the fact that the resulting FDI design is nonlinear, the involved optimization only requires linear theory, and hence, the computational problems are no harder than those involved with linear optimization based filter or control theory. To compute the linear part of the FDI system, either μ optimization or optimization based on linear matrix inequalities (LMIs) using multiplier techniques can be chosen. Furthermore, in the LMI formulation, convex optimization can be applied, which means that filters can be designed fast and efficiently.

The presented algorithm does not explicitly include exogenous disturbances or (linear or nonlinear) model uncertainty. However, handling these issues in the presented framework is straightforward, and has been described elsewhere.

Faults are represented as exogenous (vector) signals, where each component of the vector is isolated by the estimator, and the approach allows treatment of actuator faults, sensor faults, as well as internal faults.

As a final conclusion, the inherent flexibility of the standard problem approach allows any of the above methods to be combined with each other or with altogether different methods. Admittedly, a sufficiently complex set-up will lead to optimization problems that cannot be solved online even with slightly more powerful computers. Since many FDI systems are commissioned based on off-line computations, however, this is usually not prohibitive.

REFERENCES

1. Zhou K, Doyle JC, Glover K. *Robust and Optimal Control*. Prentice-Hall: New Jersey, 1996.
2. Doyle J, Glover K, Khargonekar P, Francis BA. State-space solutions to standard \mathcal{H}_2 and \mathcal{H}_∞ control problems. *IEEE Transactions on Automatic Control* 1989; **34**:831–847.
3. Nett CN, Jacobson CA, Miller AT. An integrated approach to controls and diagnostics: The 4-parameter controller. *Proceedings of the American Control Conference*, 1988; 824–835.
4. Edelmayer A, Bokor J, Keviczky L. An \mathcal{H}_∞ filtering approach to robust detection of failures in dynamical systems. *Proceedings of the 33rd Conference on Decision and Control*, Lake Buena Vista, FL, U.S.A., 1994; pp. 3037–3039.
5. Mangoubi RS, Appleby BD, Verghese GC, Van der Velde WE. A robust failure detection and isolation algorithm. *Proceedings of the 34th Conference on Decision and Control*, New Orleans, LA, U.S.A., 1995; pp. 2377–2382.
6. Mangoubi RS. *Robust Estimation and Failure Detection*. Springer: Berlin, 1998.
7. Frisk E. Residual generation for fault diagnosis: Nominal and robust design. *Thesis*. Department of Electrical Engineering, Linköping, Sweden, 1998.
8. Ajbar H, Kantor JC. An ℓ_∞ approach to robust control and fault detection. *Proceedings of the American Control Conference*, San Francisco, CA, USA, 1993; 3197–3201.
9. Qiu Z, Gertler J. Robust FDI systems and \mathcal{H}_∞ optimization. *Proceedings of the 32nd Conference on Decision and Control*, San Antonio, Texas, USA, 1993; 1710–1715.
10. Tyler ML, Morari M. Optimal and Robust Design of Integrated Control and Diagnostic Modules. *Proceedings of the American Control Conference*, Baltimore, MD, USA, 1994; 2060–2064.
11. Åkesson M. Integrated control and fault detection for a mechanical servo process. *Proceedings of the IFAC Symposium SAFEPROCESS'97*, Hull, England, 1997; 1252–1257.
12. Stoustrup J., Grimble M. J. Integrating control and fault diagnosis: A separation result. *Proceedings of IFAC Symposium on Fault Detection, Supervision and Safety for Technical Processes*, Hull, U.K., 1997; 323–328.
13. Chen J, Patton RJ. *Robust model-based fault diagnosis for dynamic systems*, Kluwer Academic Publishers: Dordrecht, 1998.

14. Chen J, Patton RJ. Standard \mathcal{H}_∞ filtering formulation of robust fault detection. *Preprints of 4th IFAC Symposium on Fault Detection Supervision and Safety for Technical Processes, SAFEPROCESS'2000*, Budapest, Hungary, 2000; 256–261.
15. Gertler J. *Fault Detection and Diagnosis in Engineering Systems*. Marcel Dekker: New York, 1998.
16. Edelmayer A, Bokor J, Keviczky L. \mathcal{H}_∞ detection filter design for linear systems: Comparison of two approaches. *Proceedings of the 13th IFAC World Congress*, Vol. N., San Francisco, CA, U.S.A., 1996; 37–42.
17. Edelmayer A, Bokor J, Keviczky L. Improving sensitivity of \mathcal{H}_∞ detection filters in linear systems. *Proceedings of 11th IFAC Symposium System Identification, SYSID'97*. Kitakyushu, Japan, 1997; 1195–1200.
18. Edelmayer A, Bokor J, Szigeti F, Keviczky L. Robust detection filter design in the presence of time-varying system perturbations. *Automatica* 1997; **33**(3):471–475.
19. Niemann HH, Stoustrup J. Integration of control and fault detection: Nominal and robust design. *Proceedings of IFAC Symposium on Fault Detection, Supervision and Safety for Technical Processes*, Hull, U.K., 1997; 341–346.
20. Stoustrup J, Grimble MJ. Integrated Control and Fault Diagnosis Design: A Polynomial Approach. *IEE Modelling and Signal Processing for Fault Diagnosis*, Leicester, U.K., 1996.
21. Stoustrup J, Grimble MJ, Niemann HH. Design of integrated systems for control and detection of actuator/sensor faults. *Sensor Review* 1997; **17**:157–168.
22. Frank PM. Fault diagnosis in dynamic systems using analytic and knowledge-based redundancy—A survey and some new results. *Automatica* 1990; **26**:459–474.
23. Frank PM. Analytical and qualitative model-based fault diagnosis—A survey and some new results. *European Journal of Control* 1996; **2**:6–28.
24. Patton RJ, Frank PM, Clark R. *Fault Diagnosis in Dynamic Systems—Theory and Application*. Prentice-Hall: New Jersey, 1989.
25. Basseville M, Nikiforov IV, *Detection of Abrupt Changes—Theory and Application* (1st edn). Prentice-Hall: Englewood Cliffs, NJ, 1993.
26. Patton RJ, Chen J. Robust fault detection and isolation (FDI) systems. *Control and Dynamic Systems* 1996; **74**: 171–224.
27. Boutayeb M, Aubry D, Frank PM, Keller JY. A separate-bias observer for nonlinear discrete-time system. *Proceedings of IFAC Symposium on Fault Detection, Supervision and Safety for Technical Processes*, Hull, U.K., 1997; 516–521.
28. Burth M, Filbert D. Fault diagnosis of universal motors during run-down by nonlinear signal processing. *Preprints of 3th IFAC Symposium on Fault Detection Supervision and Safety for Technical Processes*, Hull, U.K., 1997; 426–431.
29. Edwards C, Spurgeon SK, Patton RJ, Klotzek P. Sliding mode observers for fault detection. *Proceedings of IFAC Symposium on Fault Detection, Supervision and Safety for Technical Processes*, Hull, U.K., 1997; 522–527.
30. Frank PM, Ding SX, Köppen-Seliger B. Current developments in the theory of FDI. *Preprints of 4th IFAC Symposium on Fault Detection Supervision and Safety for Technical Processes, SAFEPROCESS'2000*, Budapest, Hungary, 2000; 16–27.
31. Polycarpou MM, Vemuri AT, Ciric AR. Nonlinear fault diagnosis of differential/algebraic system. *Proceedings of IFAC Symposium on Fault Detection, Supervision and Safety for Technical Processes*, Hull, U.K., 1997; 510–515.
32. Schreier G, Ragot J, Patton RJ, Frank PM. Observer design for a class of nonlinear systems. *Proceedings of IFAC Symposium on Fault Detection, Supervision and Safety for Technical Processes*, Hull, U.K., 1997; 498–503.
33. Shields DN, Preston G, Daley S. A nonlinear observer approach: experience with two hydraulic systems. *Proceedings of IFAC Symposium on Fault Detection, Supervision and Safety for Technical Processes*, Hull, U.K., 1997; 504–509.
34. Niemann HH, Stoustrup J. Design of fault detectors using \mathcal{H}_∞ optimization. *Proceedings of the 39th IEEE Conference on Decision and Control*, Sydney, Australia, 2000; 4327–4328.
35. Niemann HH, Stoustrup J. Fault diagnosis for non-minimum phase systems using \mathcal{H}_∞ optimization. *Proceedings of the American Control Conference*, Washington DC, U.S.A., 2001; 4432–4436.
36. Ferreres G, Fromion V, Duc G, M'Saad M. Application of real/mixed μ computational techniques to an \mathcal{H}_∞ missile autopilot. *International Journal of Robust and Nonlinear Control* 1996; **6**:743–769.
37. Doyle JC. Structured uncertainty in control system design. *Proceedings of 24th IEEE Conference on Decision and Control*, Fort Lauderdale, FL, U.S.A., 1985; 260–265.
38. Niemann HH, Stoustrup J, Tøffner-Clausen S, Andersen P. μ -synthesis for the coupled mass benchmark problem. *Proceedings of the American Control Conference*, Albuquerque, New Mexico, U.S.A., 1997; 2611–2615.
39. Tøffner-Clausen S, Andersen P, Stoustrup J, Niemann HH. A new approach to μ -synthesis for mixed perturbation sets. *Proceedings of the 3rd European Control Conference*, Rome, Italy, 1995; 147–152.
40. Tøffner-Clausen S, Andersen P, Stoustrup J, Niemann HH. Estimated Frequency Domain Model Uncertainties used in Robust Controller Design—A μ -approach. *Proceedings of the 3rd Conference on Control Applications*, Glasgow, U.K., 1994; 1585–1590.

41. Young PM. Controller design with mixed uncertainties. *Proceedings of American Control Conference*, Baltimore, Maryland, U.S.A., 1994; 2333–2337.
42. Ding X, Guo L. Observer based optimal fault detector. *Proceedings of the 13th IFAC World Congress*, Vol. N: San Francisco, CA, U.S.A., 1996; 187–192.
43. Packard A. Gain Scheduling via Linear Fractional Transformations. *Systems & Control Letters* 1994; **22**:79–92.
44. Rantzer A. Stability and gain scheduling in nonlinear control. *Workshop notes from Young Researchers Week*, Algarve, Portugal, 1996; 15–21.