

 Open access • Journal Article • DOI:10.1179/POM.1969.12.23.003

Feasibility of producing dispersion-strengthened chromium by ball-milling in hydrogen halides* — [Source link](#)

Alan Arias

Institutions: Glenn Research Center

Published on: 01 Mar 1969 - Powder Metallurgy (Taylor & Francis)

Topics: Chromium hydride, Chromium Alloys, Chromium, Hydrogen and Nickel

Related papers:

- [Effect of the particle size of starting materials on the degree of homogenization of iron-chromium alloy powders](#)
- [Pressing behavior of mixtures of dispersion-strengthened nickel and chromium powders](#)
- [Acceleration of mechanical size reduction of chromium carbide powders and mixtures based on chromium carbide](#)
- [Diffusion chromizing of graphite powders in a closed reaction volume](#)
- [Method for preparing aluminum carbide dispersion-strengthened copper](#)

Share this paper:    

View more about this paper here: <https://typeset.io/papers/feasibility-of-producing-dispersion-strengthened-chromium-by-2a9bxbydia>

NASA TECHNICAL NOTE

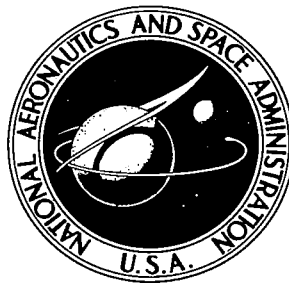

NASA TN D-4912

C.1

NASA TN D-4912



LOAN COPY: RETURN TO
AFWL (WLIL-2)
KIRTLAND AFB, N MEX

FEASIBILITY OF PRODUCING DISPERSION
STRENGTHENED CHROMIUM BY
BALL-MILLING IN HYDROGEN HALIDES

by Alan Arias

Lewis Research Center

Cleveland, Ohio

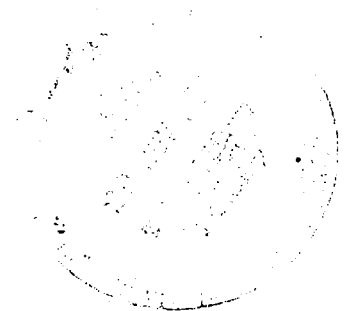



FEASIBILITY OF PRODUCING DISPERSION STRENGTHENED
CHROMIUM BY BALL-MILLING IN HYDROGEN HALIDES

By Alan Arias

Lewis Research Center
Cleveland, Ohio

NATIONAL AERONAUTICS AND SPACE ADMINISTRATION

For sale by the Clearinghouse for Federal Scientific and Technical Information
Springfield, Virginia 22151 - CFSTI price \$3.00

ABSTRACT

Chromium, with and without 4 volume percent thoria, and nickel powders were ground to fine powder sizes by ball-milling in gaseous hydrogen halides. After reducing the milled chromium in flowing hydrogen under pulsating pressure at about 680^o C, submicron-size powders with 4 to 500 ppm residual halogens were obtained. The compacted chromium-thoria alloys had interparticle spacings ranging from 2.1 to 6.5 micrometers. After 100 hours at 1318^o C the interparticle spacing of the 2.1-micrometer alloy increased to 5.2 micrometers. Submicron-size chromium and nickel powders were also obtained by pulsating hydrogen reduction of their chlorides.

CONTENTS

	Page
SUMMARY	1
INTRODUCTION	2
MATERIALS, EQUIPMENT, AND PROCEDURES	3
Materials	3
Equipment	4
Ball mills and balls	4
Rig for pressurizing ball mills with hydrogen halides	5
Retort	7
Hydrogen cleaning rig	7
Procedures	8
Loading ball mills	8
Ball-milling	9
Reduction or cleaning in hydrogen	10
Reduction of chromic chloride and nickel chloride in hydrogen	11
Encapsulation of cleaned powders	11
Hot-pressing	13
Stability anneals	13
Interparticle spacings	13
RESULTS AND DISCUSSION	13
Powders Produced by Ball-Milling	13
Particle sizes	13
X-ray diffraction analyses	14
Reaction of powders with ball-milling media	15
Chemical analyses (other than halogens)	18
Reduction of Metal Halides Produced During Ball-Milling	19
Preliminary experiments on halogen removal	19
Reduction of halides in powders used for compaction and/or analysis	20
Chemical analyses for residual halogens in reduced powders	21
Chemical analyses for oxygen, nitrogen, carbon, and iron in reduced powders	22
Reduction of Chromic Chloride (CrCl_3) and Nickel Chloride (NiCl_2) in Hydrogen	23

Isostatically Hot-Pressed Chromium-Thoria Alloys	24
Chemical analyses	24
Microstructures and interparticle spacings	24
Stability Anneals	27
Advantages of Hydrogen Iodide Ball-Milled Material	27
CONCLUDING REMARKS	27
SUMMARY OF RESULTS	28
REFERENCES	29

FEASIBILITY OF PRODUCING DISPERSION STRENGTHENED CHROMIUM BY BALL-MILLING IN HYDROGEN HALIDES

by Alan Arias

Lewis Research Center

SUMMARY

This investigation was conducted primarily to determine the feasibility of producing chromium with finely dispersed thorium dioxide, suitable for dispersion strengthening, by ball-milling in gaseous hydrogen halides. In addition, the feasibility of producing fine nickel powder by ball-milling in hydrogen bromide and of reducing chromium and nickel chlorides in hydrogen was investigated.

Ultrafine powders (0.090-, 0.084-, and 0.046- μm average particle size) were obtained by ball-milling chromium - thorium dioxide (Cr-ThO_2) powders in hydrogen chloride (HCl), hydrogen bromide (HBr), and hydrogen iodide (HI), respectively. Also, 0.043- and 0.023-micrometer powders resulted from milling chromium and nickel in HCl and HBr , respectively. From 11.6 to 18.9 weight percent of the chromium and 26.5 weight percent of the nickel were converted to the corresponding metal halides as a result of their reaction with the hydrogen halides during ball-milling.

Chromium and Cr-ThO_2 powders with 6 ppm, or less, iodine, less than 200 ppm chlorine, and 500 ppm bromine resulted after cleaning the milled powders in high-purity hydrogen under pulsating pressure. Nickel powder milled in HBr contained 2300 ppm bromine after cleaning. Pure chromic chloride (CrCl_3) and nickel chloride (NiCl_2) were reduced with hydrogen to yield 0.78- and 0.35-micrometer metal powders with 270 and 200 ppm chlorine, respectively.

Lineal analyses of electron photomicrographs of hydrogen-cleaned and isostatically hot-pressed Cr-ThO_2 alloys obtained from HI -, HBr -, and HCl -milled powders gave interparticle spacings (IPS) of 2.1, 6.5, and 3.5 micrometers, respectively. A stability anneal of the 2.1-micrometer-IPS, Cr-ThO_2 alloy for 100 hours at 1318°C increased the IPS to 5.2 micrometers.

INTRODUCTION

Among the methods of improving the high-temperature mechanical properties of chromium, dispersion strengthening has received relatively little attention, despite the proven potential of this strengthening method with other metals. Dispersion strengthening involves the production of metals or alloys with finely divided, uniformly distributed, inert dispersoid particles. The interparticle spacing (average distance between dispersoid particles) is one of the main factors governing the strength of these alloys. The interparticle spacing (IPS), in turn, is a function of the dispersoid particle size and the volume percentage of the dispersoid (ref. 1).

If a dispersion strengthened alloy is to be useful, the interparticle spacing must be maintained for long periods of time at the use temperature. In other words, the dispersoid must be stable. Stable dispersoids have a large negative free energy of formation, a high melting point, low solubility in the matrix, and a small dissociation pressure (e. g. , see refs. 2 and 3). Although there are a large number of potential dispersoids with these characteristics, availability in a suitable size and feasibility of introducing them into the metal or alloy matrix limit the choice. The feasibility of introducing the dispersoid into the matrix, in turn, depends on the method of dispersing the particles. Of the available methods of producing dispersions of inert particles in metals and alloys (ref. 3), ball-milling appears to have a good chance for success. Also, the ball-milling procedure is versatile and has scale up potential. This well-known method has been used at the Lewis Research Center for producing dispersions in a variety of materials (refs. 4 and 5).

The ball-milling method of producing dispersions generally involves ball-milling the metal and dispersoid powders in a suitable medium. As shown in a recent investigation by the author (ref. 6), metals that reacted to some degree with the ball-milling media during the process could be comminuted to very fine particle size, whereas those that did not react with the media were not comminuted. The contamination resulting from the reaction of the comminuted powders with the ball-milling media is generally large. Although reaction with the grinding media is required for comminution of the powders to very fine particle sizes, the reaction products are usually detrimental and must ultimately be eliminated. Hence, if the usefulness of the ball-milling method of achieving a dispersion is to be realized, ball-milling must be carried out in a medium such that the impurity pickup or reaction products can be readily removed by thermochemical treatments. To avoid agglomeration of the dispersoid and to reduce or prevent the premature formation of closed pores (in which the impurities could be trapped), it would be desirable to use low cleaning temperatures. This, in turn, would require that the reaction products in the powder blend be also removable at low temperatures. Chromium halides produced during ball-milling would be both reducible with hydrogen and volatile at relatively low

temperatures. Preliminary experiments in which chromium was ball-milled in hydrogen halide gases yielded fine-powdered chromium contaminated with chromium halides. It was surmised that the reduction of halides formed during ball-milling might be carried out without excessive agglomeration of intentionally added oxides.

The present investigation was conducted to determine the feasibility of producing chromium with finely dispersed thorium dioxide, suitable for dispersion strengthening, by ball-milling in gaseous hydrogen halides. It was also intended to determine the high-temperature stability of some of the resulting consolidated products and, in addition, to evaluate the effectiveness of some processing techniques and the use of metal halides as starting materials.

In order to carry out the objectives of this investigation, chromium and thorium dioxide powders were ball-milled in gas-tight ball mills provided with pressure gages. Hydrogen chloride, hydrogen bromide, and hydrogen iodide gases under pressure were used as grinding media. In addition, because of the possible use of the method for nickel-chromium alloys, the feasibility of comminuting nickel alone by ball-milling in hydrogen bromide was investigated. Chemical, surface-area, and X-ray diffraction analyses of the ball-milled powders were carried out. Ball-milled powders were cleaned by heating them in flowing hydrogen. Since on ball-milling in hydrogen halides, the halides of the ball-milled powders are formed, the feasibility of reducing chromium trichloride and nickel dichloride by heating them in flowing hydrogen was also investigated.

The cleaned Cr-ThO₂ alloys were consolidated by hot-pressing. The microstructures of all the alloys were investigated, and the microstructural stability of one of the consolidated Cr-ThO₂ alloys was studied.

MATERIALS, EQUIPMENT, AND PROCEDURES

Materials

The materials used in this investigation (shown in table I) were high-purity electrolytic chromium flake; nickel powder; anhydrous chromic chloride (CrCl₃); anhydrous nickel chloride (NiCl₂); gaseous hydrogen chloride, hydrogen bromide, and hydrogen iodide; high-purity argon; and colloidal thorium dioxide. The chromium powder used in this investigation was made by hammer-milling high-purity electrolytic chromium flake under argon until the powder passed a 30-mesh sieve. The chemical analyses (or manufacturer's specifications) and purities of the raw materials used are also given in table I.

Equipment

Three pieces of specialized equipment were used in this investigation, a ball mill with pressure gage (fig. 1), a rig for evacuating the ball mills and pressurizing them with hydrogen halides (fig. 2), and a retort for cleaning the ball-milled powders in hydrogen (fig. 3). The retort is part of an overall hydrogen cleaning rig shown in figure 4. Detailed descriptions of this specialized equipment follow.

Ball mills and balls. - The type of ball mill used in this investigation is shown in figure 1. The mills were made from type 410 stainless steel and have a nominal inside diameter of 10.2 centimeters and a capacity of approximately 1580 cubic centimeters. The covers for the mills have fluorocarbon O-ring gaskets to provide a gas-tight seal. The mills can be pressurized to approximately 20 atmospheres ($20 \times 10^5 \text{ N/m}^2$) without leaking. The ball-mill pressure can be monitored with a 7.5-centimeter-diameter, stainless-steel gage attached to the ball-mill cover. The as-calibrated accuracy of these gages is better than 0.035 atmosphere (3500 N/m^2). Vacuum valves are used either for evacuating the mills or for pressurizing them with the gases used as ball-milling media.

In some of the ball-milling runs a cage was used for the balls (see fig. 1). This

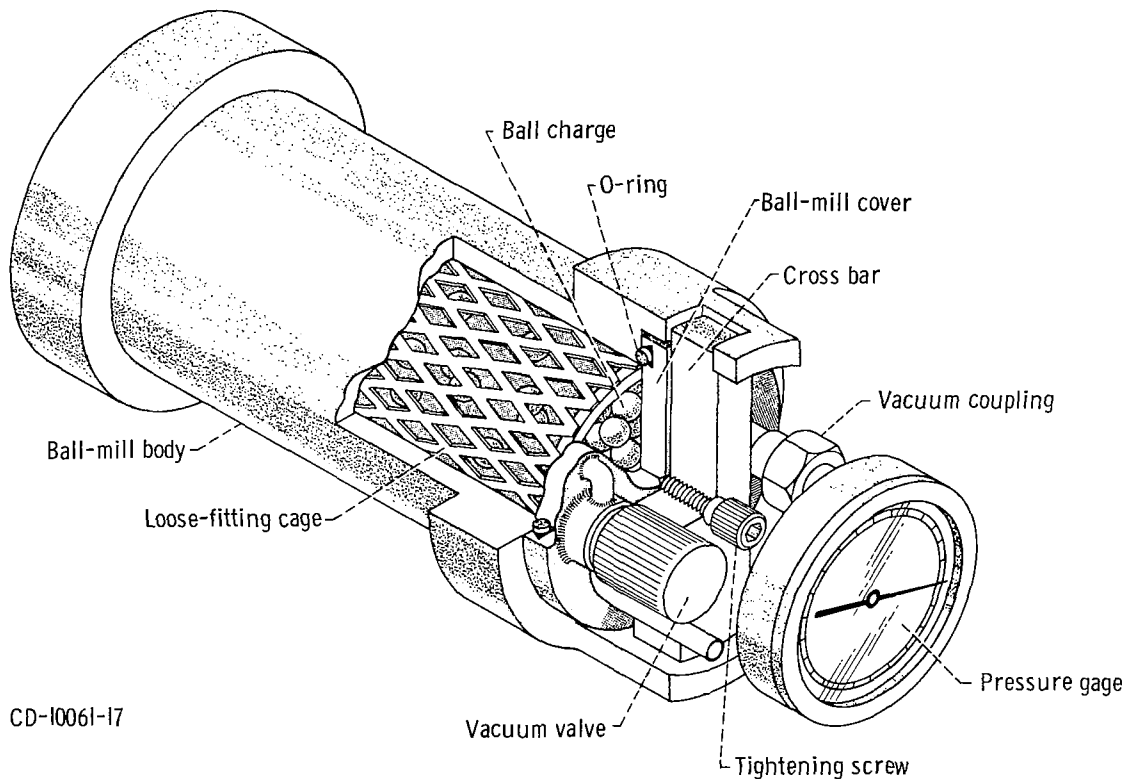

Figure 1. - Ball mill with pressure gage and cage.

cylindrical cage was made from expanded, type 304 stainless-steel sheet. The outside diameter of the cage is about 3 millimeters smaller than the inside diameter of the ball mill, and the ends of the cage clear the top and bottom of the ball mill by about 0.8 millimeter. The openings of the cage are about 5 millimeters wide, so that the smallest balls used did not touch the inside diameter of the ball mill. In operation, the cage treads on the internal surface of the mill and in so doing scrapes the powder from the ball-mill walls, preventing its accumulation and subsequent caking. The runs in which the cage was used are indicated in table II.

The balls used for ball-milling were type 316 stainless steel. Only two sizes of balls, 12.6 and 6.3 millimeters nominal diameter, were used.

Rig for pressurizing ball mills with hydrogen halides. - The ball mills were evacuated and then pressurized with the hydrogen halides used as ball-milling media with the rig shown schematically in figure 2. For safety, the pressurizing operation was carried out inside an argon- or helium-filled glove box. A similar arrangement was used for evacuating and then pressurizing the ball mill for the run with argon.

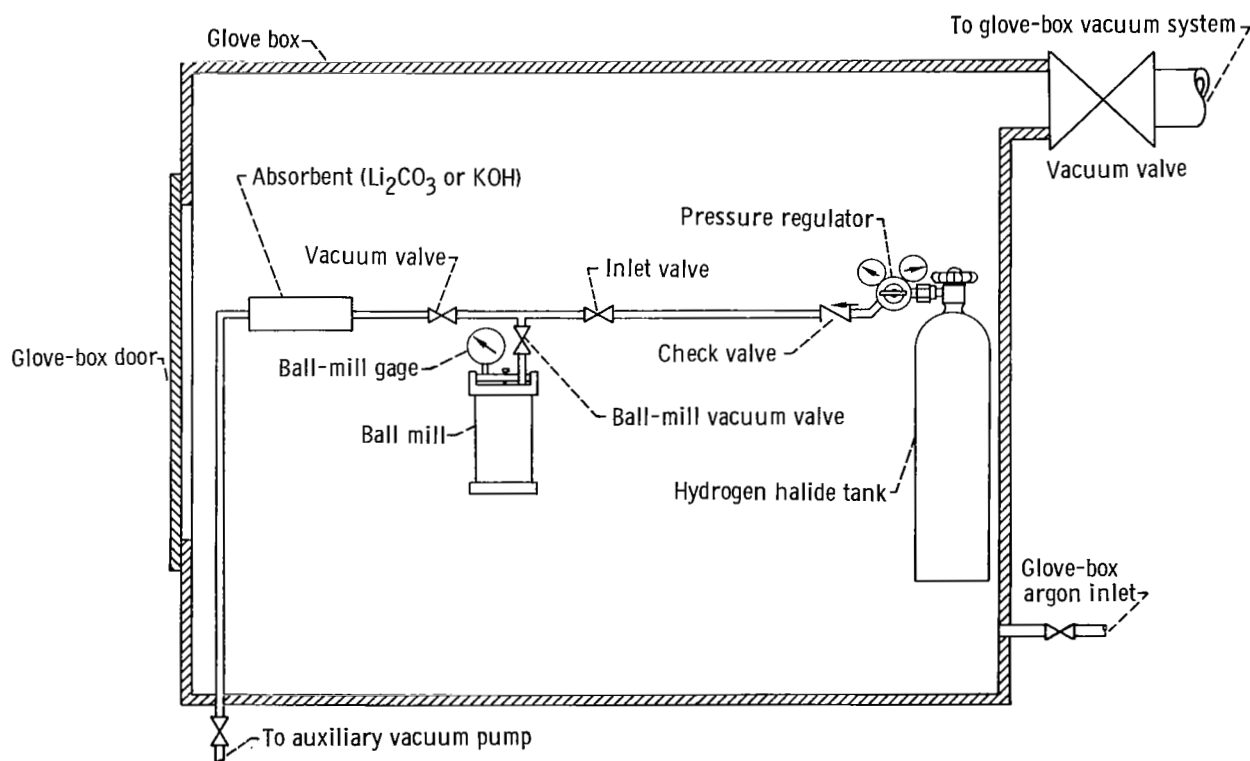

Figure 2. - System for pressurizing ball mills with hydrogen halides.

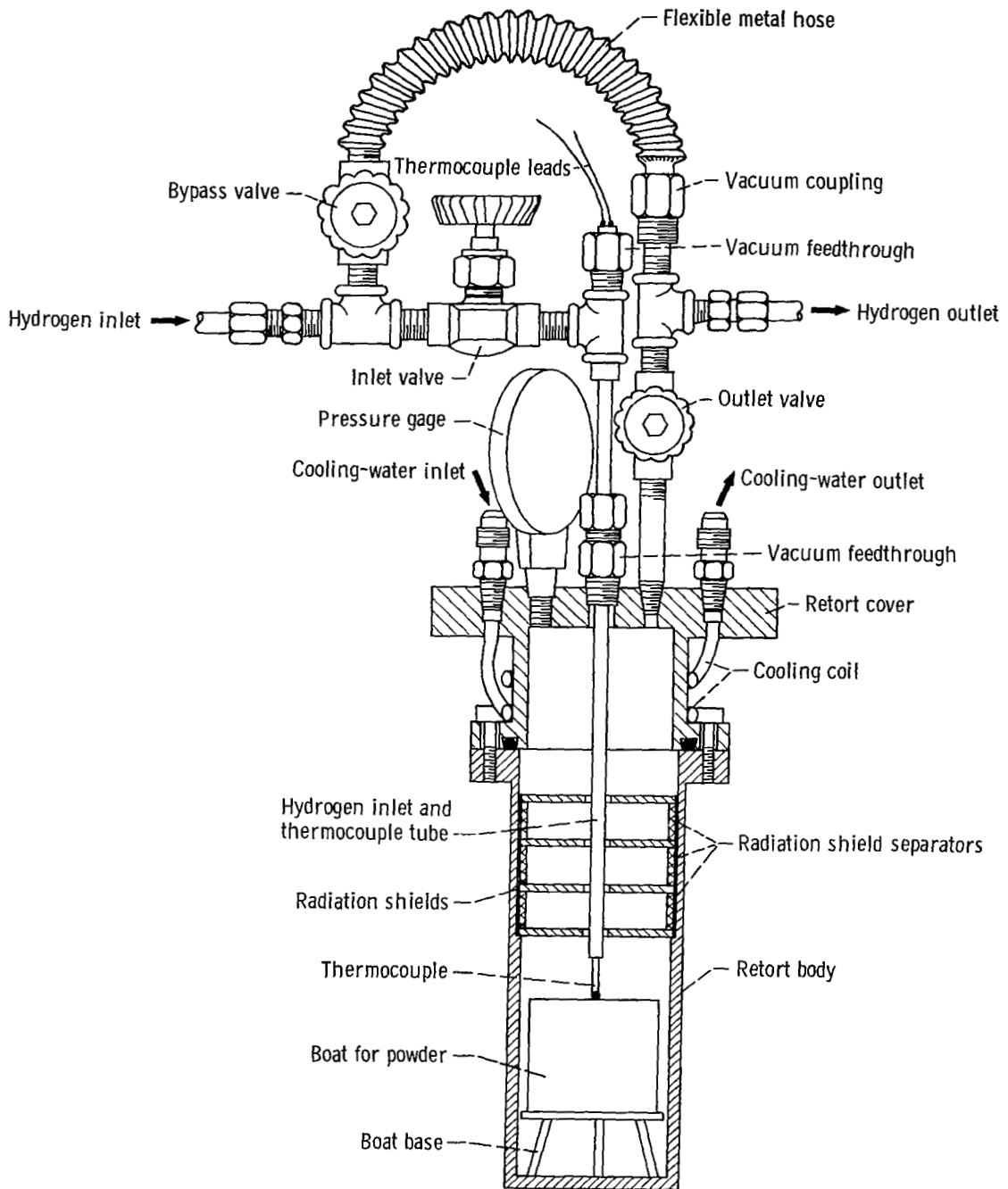

Figure 3. - Retort assembly.

Retort. - The hydrogen cleaning retort used in this investigation is shown schematically in figure 3. The water-cooled head or cover was made from brass. The body of the retort, the radiation shields, the boats for powders, and the hydrogen inlet tube were made from type 316 stainless steel. The inside diameter of the retort was 5 centimeters and the usable length (from the radiation shields down) about 12 centimeters. The assembled retort could be pressurized to about 20 atmospheres ($20 \times 10^5 \text{ N/m}^2$) without leakage. This type of construction was used to prevent air contamination of the ball-milled or cleaned powders during transportation of the retort to and from the cleaning rig. The cover of the retort was made so that it could also serve as a cover for the induction-heated vacuum furnace in which the retort was heated during the hydrogen cleaning operation.

Hydrogen cleaning rig. - A schematic diagram of the hydrogen cleaning rig (with the retort in position) used for reducing or cleaning the ball-milled powders is shown in figure 4. The hydrogen used was standard, bottled hydrogen purified by passing it through a palladium-silver purifier.

The main distinguishing feature of this hydrogen cleaning rig is a recycling timing relay and solenoid valve arrangement used to cause a rhythmic hydrogen pressure variation in the retort. This rhythmic hydrogen pressure variation, or pulsating hydrogen

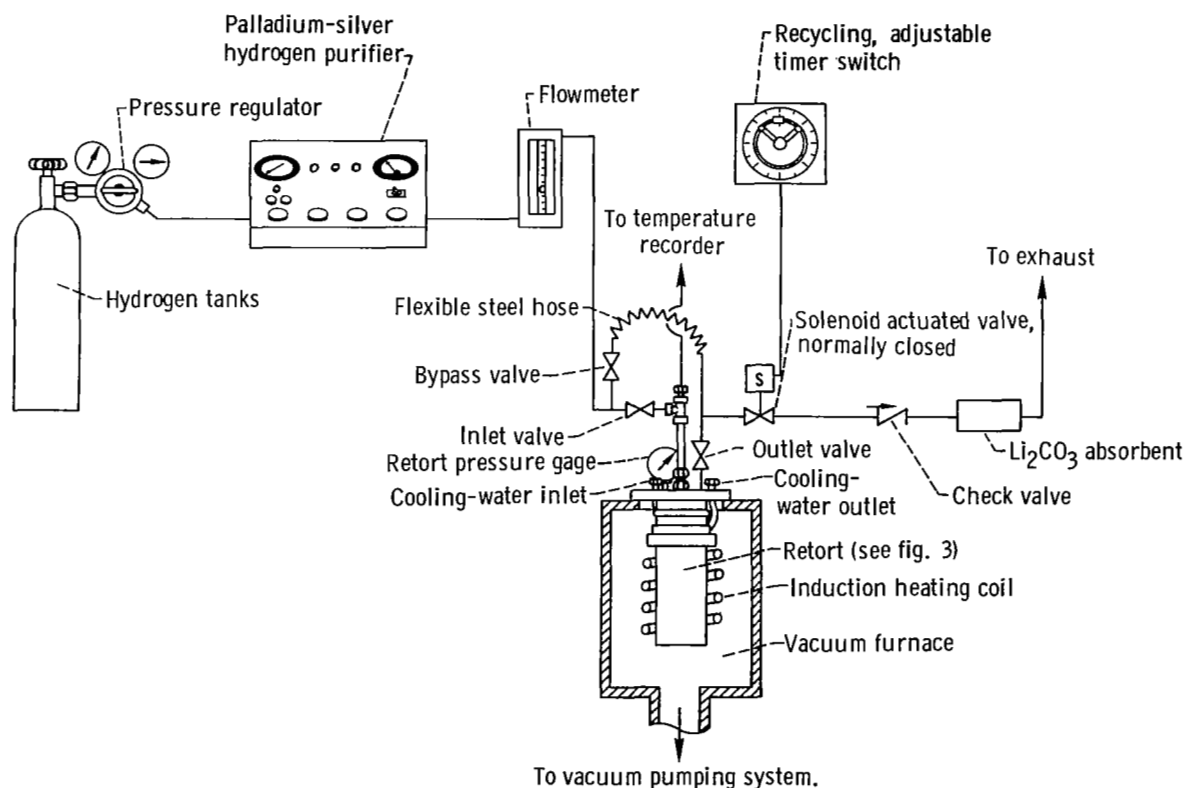

Figure 4. - Hydrogen cleaning rig.

pressure, was used because it was believed that it would facilitate the removal of reaction products from the voids between the powder particles.

The recycling timing switch or relay is adjustable from 0 to 60 minutes in either the on or off position. This timing relay activates or deactivates a normally closed solenoid valve located in the outlet side of the retort. When the solenoid valve is closed, the hydrogen pressure in the retort builds up to whatever pressure the hydrogen purifier was set to deliver. The time required to reach a given pressure in the retort depends on the characteristics of the purifier used and the impedance of the line between the purifier and the retort. Usually, very little change in the hydrogen flow can be made with the purifier itself except by using purifiers of different capacities. The only variable that can be readily adjusted in the purifier is its inlet pressure which, in turn, determines the purifier outlet pressure or the maximum pressure attainable in the retort. The time required to reach a selected purifier outlet pressure will be determined by the impedance of the line between the purifier and the retort. In this investigation, the impedance was adjusted by means of an inlet valve to the retort (see fig. 4), and the time required to lower the pressure to some preselected value (upon opening the solenoid valve) could be adjusted by means of an outlet valve. Hence, by adjusting the hydrogen pressure inlet to the purifier, the on-off cycle of the timer, and the inlet and outlet valves, the hydrogen pressure in the retort could be made to pulsate between preselected values at a predetermined number of cycles per hour. In this study, the rig was always run at 60 pulses per hour with the purifier inlet gage pressure maintained at approximately 4 atmospheres ($4 \times 10^5 \text{ N/m}^2$) and the inlet and outlet retort valves adjusted so that the retort gage pressure pulsed between 0.15 and 1.1 atmospheres (0.15×10^5 and $1.1 \times 10^5 \text{ N/m}^2$). In case of power failure, the solenoid valve would close and the retort pressure would build up to almost 4 atmospheres.

Procedures

The procedures used in this investigation are described in the order shown in the flow diagram of figure 5. Unless otherwise noted, all the operations (loading ball mills, ball-milling, unloading ball-milled powders, loading retorts, unloading retorts, taking powder samples, and encapsulating powders for isostatic hot-pressing) were carried out in an argon- or helium-filled glove box.

Loading ball mills. - The metal powders (chromium and nickel) and the thorium dioxide were weighed on an analytical balance inside a glove box and loaded in the mills, together with the ball charge and cage (if used). In all the runs with chromium and thorium dioxide, 141.7 grams of chromium powder and 8.23 grams of thorium dioxide were used. This amount of thorium dioxide represents 4 volume percent in the compacted

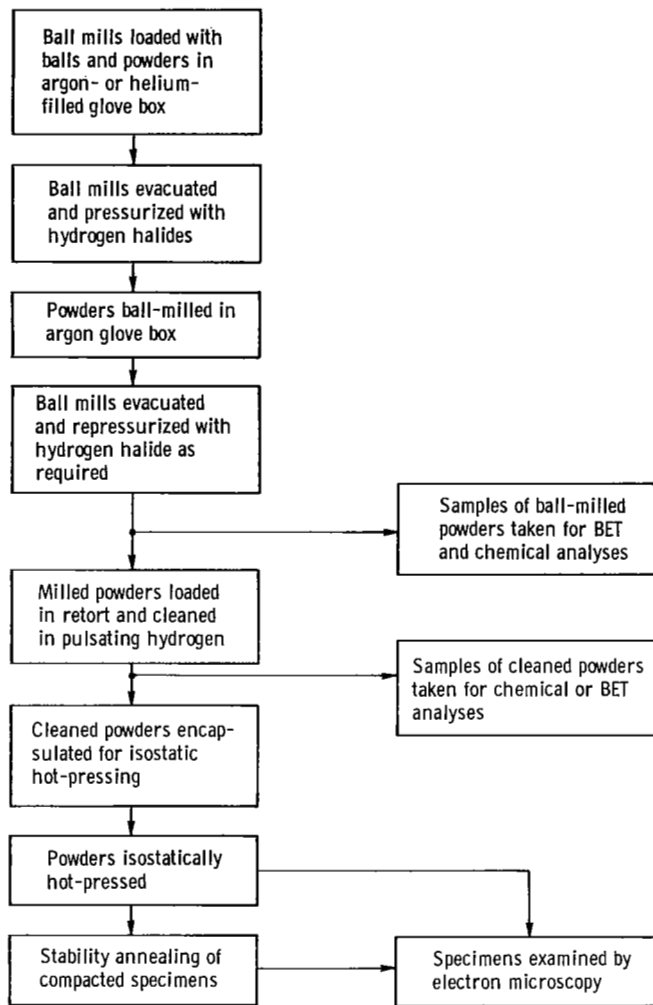

Figure 5. - Flow chart for preparation of chromium with 4 volume percent thorium dioxide dispersoids.

Cr-ThO₂ alloy. In the runs with either pure chromium or pure nickel, 150.0 grams of the metal powders were used. The number, size, and weight of the balls used in each run are given in table II. Each of the ball-milling runs has been assigned a number for ease of reference. The same number is used to indicate the subsequent cleaning and hot-pressing processing steps.

The gases used as ball-milling media as well as the approximate maximum gas pressures are also shown in table II.

Ball-milling. - Ball-milling was carried out on a rack placed inside an argon-filled glove box. All the ball mills were rotated at 100 rpm. During each run, the ball-mill

pressure was monitored. The ball-mill gage pressure during run 1 (with argon) remained constant at the original value (approx. 9 atm). In all runs with hydrogen halides, the ball-mill pressures decreased with time as a result of reaction of the hydrogen halide with the metal powders. At intervals depending on the rate of depletion of the hydrogen halide, the ball mill was removed from the rack, and then evacuated with a mechanical vacuum pump and repressurized with the same gas using the rig shown in figure 2. Each ball-milling run was continued for the time shown in table II.

At the end of each run with hydrogen halides the ball mills were evacuated and opened under argon in a glove box (fig. 2). The ball-milled powders were separated from the balls by sieving. Samples of the powders were taken for chemical analyses and/or surface-area analyses by the BET method (ref. 5). Some of the powders were loaded into thin, glass capillary tubes for X-ray diffraction analyses. The open ends of these capillary tubes were sealed with vacuum grease before they were removed from the glove box. The remainder of the powder from each run was kept in a gas-tight, stainless-steel can until ready for cleaning.

The ball-milling of chromium in argon (run 1, table II) was carried out for the purpose of comparing the resulting particle size with that obtained by ball-milling in hydrogen chloride (run 2, table II). The use of a cage (fig. 1) was found necessary for ball-milling chromium in argon because without the cage the chromium caked on the ball-mill walls. For this reason, the practice of using a cage for ball-milling in hydrogen halides was continued for some experiments (runs 2 to 5, table II). However, later experiments (runs 6 and 7, table II) showed that the use of a cage was not necessary in order to obtain comminution of the powders to very small particle sizes during ball-milling in hydrogen halides.

Reduction or cleaning in hydrogen. - The use of hydrogen under pulsating pressure for sintering (and presumably, the simultaneous cleaning) of metal powders has been reported in the literature (ref. 7). However, the means of obtaining the pulsating pressure were not described.

In the present investigation, for reduction in hydrogen, an estimated 10 to 30 grams of a given powder were placed in a stainless-steel boat and weighed on an analytical balance in the glove box. The boat was placed in the retort shown in figure 3; the retort was closed with its cover and then pressurized with about 1 gage atmosphere (10^5 N/m^2) of helium. The retort was checked for leaks with a mass-spectrometer-type leak detector. If no leaks were found, the retort was placed in the induction-heated furnace and connected to the hydrogen and cooling water lines, as shown in figure 4. The bypass valve was opened, and the lines were purged with hydrogen for about 15 minutes. Then the bypass valve was closed, and the inlet and outlet valves were opened and adjusted so that with the recycling timing relay in operation the retort hydrogen pressure pulsated between 0.15 and 1.1 atmospheres (0.15×10^5 and $1.1 \times 10^5 \text{ N/m}^2$). The furnace was evacuated,

and the power input to the induction-heating coil was adjusted so as to obtain the desired operating temperature. This temperature was monitored with a Chromel-Alumel thermocouple extending inside the powder boat and connected to a recording potentiometer. The temperatures for each of the cleaning runs are shown in table III and are estimated to be accurate within $\pm 5^{\circ}$ C. Suitable operating-temperature ranges for each type of hydrogen halide ball-milled chromium powder were established by preliminary trial runs in which a fixed amount of powder was heated for 3-hour intervals at successively higher temperatures. The weight loss at each temperature was determined by weighing the boat and powder after each run. The effect of cleaning time (at 625° C) on the weight lost by the HCl-ball-milled chromium from run 2 (table II) was also determined. The temperature used for cleaning the HBr-milled nickel powder was found to be satisfactory (suitable reduction rates with no caking) during the first trial run at 350° C. In the actual runs reported in table III, the boats were loaded with powders and cleaned in a manner similar to that used in the preliminary trial runs. The retorts were removed from the cleaning rig at various intervals and taken to the glove box where the powders in the boats were weighed. This procedure of cleaning and weighing was continued until the powders no longer showed a weight loss. Samples of the cleaned powders were taken for chemical analyses and/or surface-area analyses by the BET method (ref. 8). Samples for oxygen analyses were placed in tin capsules and sealed. The remainder of the cleaned powders were used for making hot-pressed specimens.

Reduction of chromic chloride and nickel chloride in hydrogen. - The feasibility of obtaining chromium and nickel powders by reduction of their chlorides in hydrogen was also investigated because, if successful, it would offer an alternative approach to the production of dispersion strengthened chromium and nickel or their alloys. This new approach would be to ball-mill the metal chloride and the dispersoid (instead of the metal and dispersoid) followed by reduction of the chloride in hydrogen.

About 30-gram batches of as-received anhydrous chromic chloride (CrCl_3) and anhydrous nickel chloride (NiCl_2) were also reduced to the metal in pulsating hydrogen. The chlorides were loaded in stainless-steel boats in the as-received condition and weighed on an analytical balance. The boats were loaded in retorts and cleaned in hydrogen by the same method used for the ball-milled powders. Chemical analyses and surface-area analyses (by the BET method) were also carried out on the resulting powders.

Encapsulation of cleaned powders. - The cleaned Cr- ThO_2 powders were encapsulated for isostatic hot-pressing as shown in figure 6. The powders were first placed in tantalum thimbles approximately 9 millimeters in outside diameter and about 5 centimeters long. The powder in each of the thimbles was packed by pressing it at low pressure (about 25 kilograms per square centimeter (245 N/cm^2)) in a small hydraulic press. The top of each thimble was closed by crimping the wall (approx. 0.01 millimeter thick). Each loaded thimble was placed in a stainless-steel hot-pressing can or tube approxi-

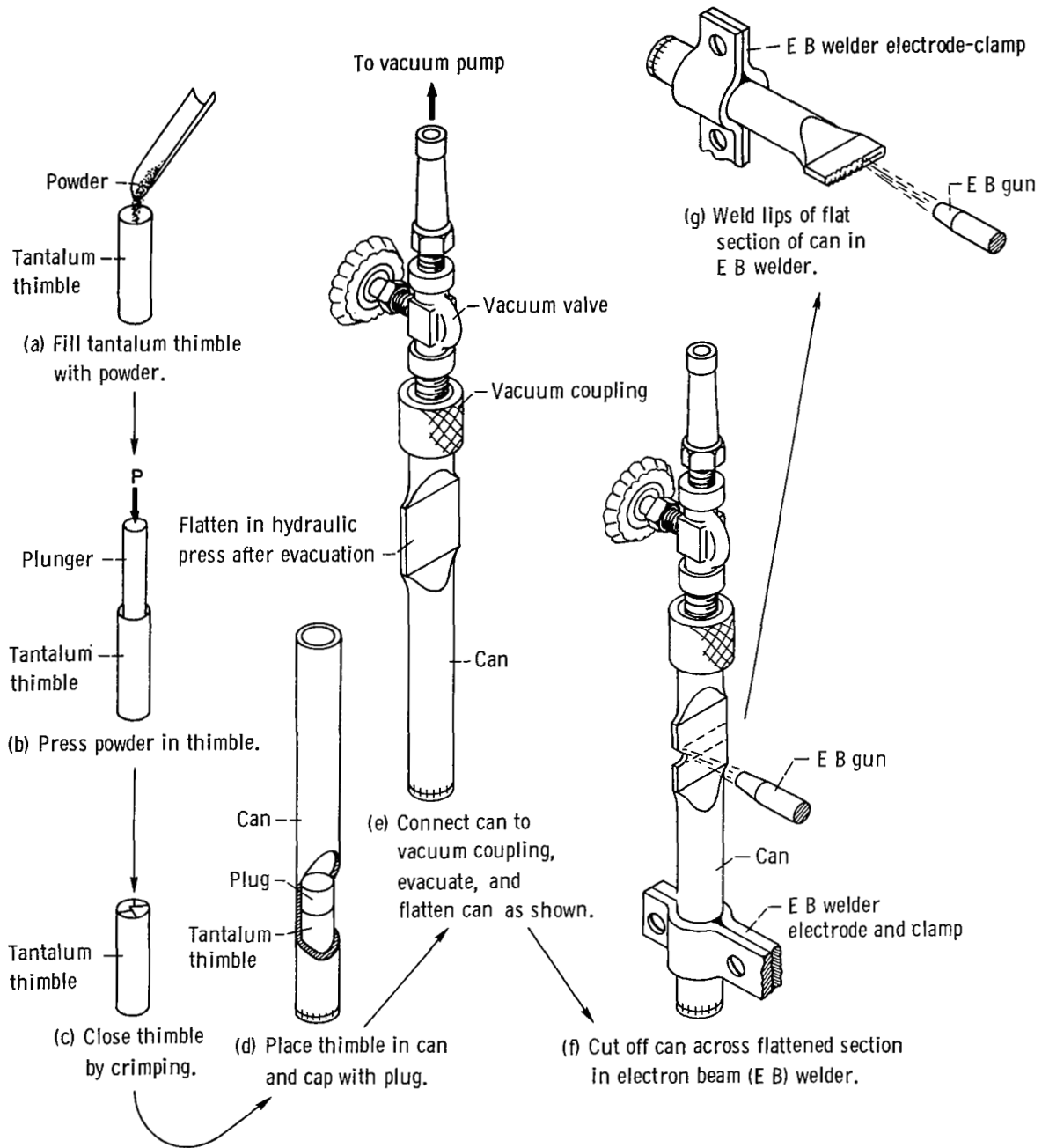

Figure 6. - Canning of powders for gas-pressure bonding.

mately 17.5 millimeters in outside diameter and 17.5 centimeters long. The thimble was capped with a stainless-steel, loose-fitting plug. A vacuum coupling with valve (see fig. 6(e)) was connected to each tube, and the tube was evacuated to less than 0.0001 torr. While still connected to the vacuum system, each tube was placed in a small hydraulic press and flattened as shown in figure 6(e). The vacuum valve was then closed, and the tube was taken to the electron beam welder for cutting and welding as shown in figures 6(f) and (g). This encapsulation method was used in order to prevent contamination of the powders with air.

Hot-pressing. - The encapsulated powders were isostatically hot-pressed in a high-pressure, high-temperature autoclave (or isostatic gas-pressure bonding furnace) where pressure was applied with helium. All the cans or tubes used to obtain the Cr-ThO₂ specimens listed in table III were hot-pressed at 1093⁰ C and 747 atmospheres (757×10^5 N/m²) for 2 hours. These hot-pressing conditions were selected on the basis of previous work with chromium reported in the literature (ref. 9). All the compacted Cr-ThO₂ alloys were chemically analyzed for thorium and oxygen. Electron photomicrographs of the hot-pressed specimens were obtained by using a replication technique.

Stability anneals. - The Cr-ThO₂ alloy obtained by cleaning and hot-pressing the powder from ball-milling run 5 (table II) was given stability anneals in helium at a gage pressure of about 1 atmosphere (10^5 N/m²) at the temperatures and times shown in table IV. Electron photomicrographs of the annealed materials were taken by using a replication technique.

Interparticle spacings. - Interparticle spacings were determined from the electron photomicrographs by the linear intercept method. Straight lines were drawn at random in the electron photomicrographs, and at least 100 intersections with dispersoid particles were counted to calculate the interparticle spacing.

RESULTS AND DISCUSSION

Powders Produced by Ball-Milling

The surface areas and particle sizes of the Cr-ThO₂, chromium, and nickel powders obtained by ball-milling in argon and in hydrogen halides are listed in table II. This table also contains the calculated amounts of halogens which reacted with the powders during ball-milling and the chemical analyses of the milled powders. A number has been assigned to every milling run listed in table II. The powder resulting from each of the runs is designated with the same number in subsequent processing operations.

Particle sizes. - As shown in table I, the original particle sizes of the chromium and nickel powders used in this investigation were 5 and 1.2 micrometers, respectively. As

shown in table II, the original chromium was ground to a particle size of 0.59 micrometer by ball-milling in argon (run 1), whereas the chromium ball-milled in reactive hydrogen halide gases was ground to particles ranging from 0.043 to 0.090 micrometer. Nickel (run 7) was ground in HBr gas to the smallest particle size (0.023 micrometer) obtained in this investigation. Although the milled powders are designated as chromium or nickel, it should be understood that this refers to the metal powders coated with varying amounts of the corresponding metal halides.

The particle sizes of the powders obtained by ball-milling chromium in hydrogen halides are considered to be small enough (<0.1 micrometer) for dispersion strengthening applications. Comparison of particle-size data for runs 3, 4, and 5 in table II shows that, other things (milling time, milling speed, etc.) being equal, HI is better than HBr, and HBr is better than HCl as milling media for producing fine powders. No quantitative particle-size comparisons among the other runs can be made because different milling conditions were used in each of these other runs. However, some qualitative comparisons can be made. Thus, comparison of particle sizes from runs 5 and 6 shows that ball-milling without a cage can also produce very-fine-particle-size powder. Also, comparison of the particle size of the nickel ball-milled in HBr (run 7) with that resulting from ball-milling chromium (with 4 volume percent thoria) in HBr (run 4) indicates that finer powders can be comminuted from nickel than from chromium. From these results it is surmised that alloys of nickel and chromium can be comminuted to submicron-size powders by ball-milling in hydrogen halides.

Observations of the ball-milling process showed that, in addition to producing fine-particle-size powders, the use of hydrogen halides as milling media offers advantages not immediately apparent. For example, whereas the chromium powder ball-milled in argon stuck tenaciously to balls, cage, and mill, the powders ball-milled in hydrogen halides did not. After separating the powders ball-milled in hydrogen halides from the balls, the balls as well as the mills remained bright and easily cleaned with soap and water. Another advantage of ball-milling with hydrogen halides stems from the fact that no liquids are used. Ball-milling with liquids requires complex filtering, washing, and drying operations. These operations are not only time consuming but also increase the likelihood of contaminating the powders during processing. In contrast, the powders produced by ball-milling in hydrogen halides are ready for thermochemical treatments (reduction or cleaning) immediately after ball-milling. Further, since the halides produced during ball-milling coat the particles, the coating can be expected to protect (to some extent) the powders from contamination by air during further processing.

X-ray diffraction analyses. - Although all the ball-milled powders were analyzed by X-ray diffraction, only the powders milled in HBr showed a metal halide pattern. The chromium ball-milled in HBr (run 4, table II) showed chromic bromide (CrBr_3), and the nickel ball-milled in HBr (run 7, table II) showed nickel bromide (NiBr_2). Since chlorine

is more reactive than bromine, it is surmised that the HCl-milled chromium powders have the chlorine in the form of CrCl_3 . Further, since chromic iodide (CrI_3) decomposes into chromous iodide (CrI_2) and iodine (I_2) at about 350°C (ref. 10) and no condensations of free iodine were noted during thermochemical treatments (to be described later), it is surmised that the reaction of hydrogen iodide with chromium during ball-milling produces CrI_2 .

Reaction of powders with ball-milling media. - The use of hydrogen halide gases as ball-milling media stems from previous work by the author on the role of chemical reactions in the comminution of metals and alloys during ball-milling (ref. 6). It was postulated in that work that extensive comminution of metals and alloys during ball-milling requires their reaction with the grinding media. Hence, the grinding media should be chosen so that the undesirable components in the product of the reaction are easily removed from the milled powders by thermochemical treatments. The hydrogen halides used as milling media in this investigation form metal halides during ball-milling according to the following chemical equations:

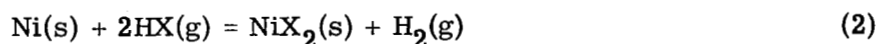
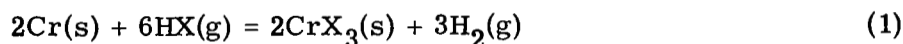

where X is one of the halogens.

A knowledge of the amounts of halogens reacted with the milled powders is of significance in subsequent reducing (or cleaning) operations. The halogen reacted with the powders during ball-milling can be determined either from the amounts of hydrogen halide used up or by chemical analyses of the ball-milled powders.

The amounts of hydrogen halide used up during ball-milling can be readily calculated from the change in ball-mill pressure ΔP (or from their sum $\sum \Delta P$) and from the free volume of the mill V (where V is 986 to 1075 cubic centimeters, depending on the mill). These values are substituted in the following (Boyle's law) equation:

$$Y = \text{Total grams of halogen used} = \frac{2\sum \Delta P(\text{atm}) \times V(\text{liters}) \times M}{22.4 \text{ liters-atm/mole}} \quad (3)$$

where M is the gram atomic weight of the halogen. The factor 2 stems from the fact that when 2 moles of hydrogen halide react with the metal being ball-milled, 1 mole of hydrogen gas is formed, as shown by the chemical equations (1) and (2).

The decrease in ball-mill pressure ΔP as a function of time for runs 3 (with HCl), 4 (with HBr), and 5 (with HI) are shown in figures 7(a), (b), and (c), respectively. The corresponding curves for runs 2, 6, and 7 are similar to the ones in these figures and

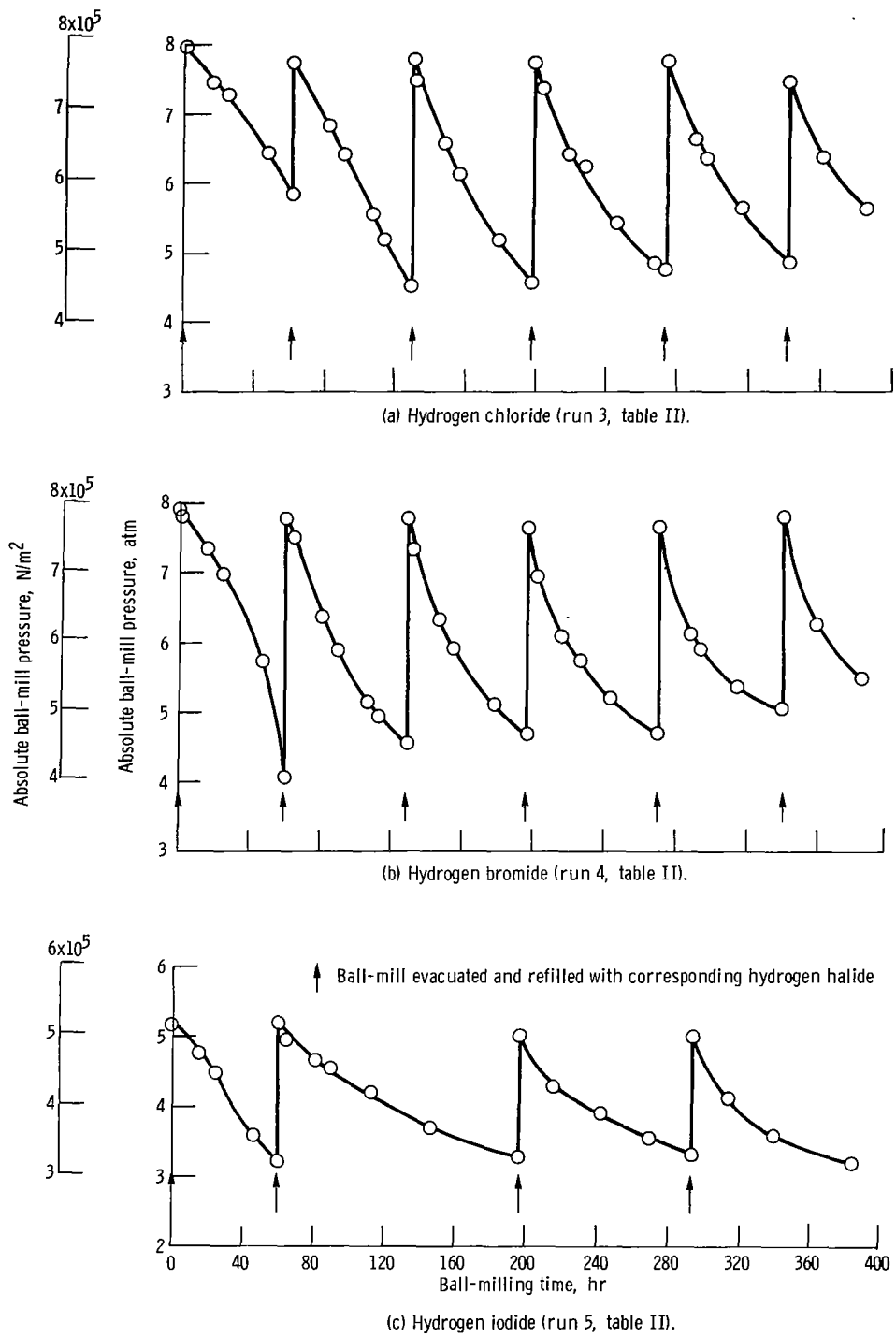

Figure 7. - Decrease in mill pressure on ball-milling Cr-ThO₂ powders in hydrogen halides.

for this reason are not shown. In addition, the ΔP data for run 6 were not used for calculations because the pressure gage was found to be defective at the end of the run. In contrast to the quite large decreases in ball-mill pressure which occur during ball-milling in hydrogen halides, no significant change in ball-mill pressure was observed during the ball-milling of chromium in argon (run 1).

The amounts of halogens reacted with the powders during ball-milling and calculated with the aid of equation (3) for milling runs 3 (with HCl), 4 (with HBr), and 5 (with HI) are shown in figure 8. The curves for the other runs (2, 6, and 7) were not included because they are similar to the ones shown and would not contribute significantly to the conclusions reached. It should be noted that in figure 8 the amounts of halogens reacted are given in grams of halogen per gram of original chromium. These values were obtained by dividing the total amount of halogen reacted (as obtained with eq. (3)) by the 141.8 grams of chromium in the powder charge used for each run. A sample of the calculations used for obtaining the points in figure 8 from the pressure data in figure 7 follows.

From figure 7(a), the decrease in ball-mill pressure ΔP between 0 and 60.3 hours is $7.98 - 5.86 = 2.12$ atmospheres; and the ΔP between 60.3 and 128.7 hours is $7.75 - 4.54 = 3.21$ atmospheres. Then, the sum of the changes in ball-mill pressure be-

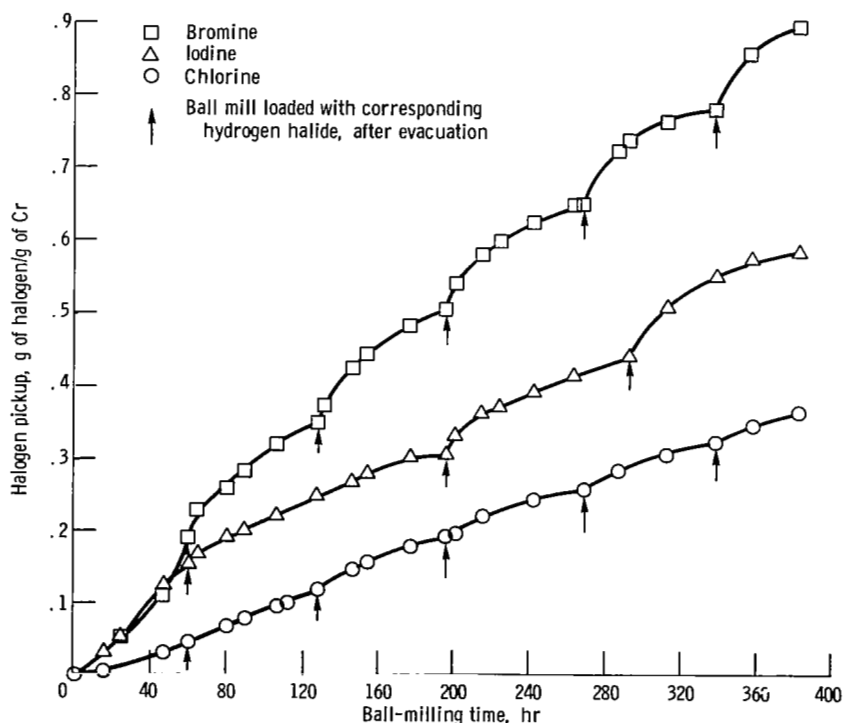

Figure 8. - Chlorine, bromine, and iodine reacted with chromium on ball-milling Cr-ThO₂ powders (runs 3, 4, and 5, respectively, table II).

tween 0 and 128.7 hours is $\sum \Delta P = 2.12 + 3.21 = 5.33$ atmospheres. Substituting this $\sum \Delta P$ value together with the known free volume of the mill V (994 cm^3 , in this case) and the gram atomic weight for chlorine M (35.46 g/g atom) in equation (3) results in

$$Y = \text{Total grams of chlorine used up to 128.7 hours} = \frac{2 \times 5.33 \times 0.994 \times 35.46}{22.4}$$

$$= 16.8 \text{ grams}$$

This is equivalent to $16.8/141.8$ or 0.119 gram of chlorine per gram of original chromium. All the other points plotted in figure 8 were obtained in a similar manner.

The calculated amounts of halogens reacted for all the runs for which there were reliable ΔP data (i. e., runs 2 to 5 and 7) are included in table II. The values listed in that table were obtained by substituting Y from equation (3) in the following equation:

$$\text{Percent halogen in powder} = \frac{Y}{150 + Y} \times 100 \quad (4)$$

where the 150 in the denominator is the total powder charge (either metal or metal plus dispersoid). The amounts of halogen in the ball-milled powders calculated in this manner may be directly compared with the values obtained by chemical analyses of the ball-milled powders. These values are also reported in table II.

Since equation (3) is valid for ideal gases only and there are other sources of error (such as gage accuracy, temperature changes, etc.), the calculated amounts of halogens in the milled powders shown in table II and in figure 8 can be expected to be only approximate. Even so, the calculated values agree quite well with the results of chemical analyses. As shown in table II, the weight percentages of halogens in the milled powders are quite large and (based on chemical analyses) range from 25.4 (run 3) to 45.9 (run 4). The weight percentages of metals converted to halides are much smaller than these figures would indicate and ranged from 11.6 (run 5) to 26.5 (run 6).

Instead of the hydrogen halides, the halogens themselves could have been used in this investigation. However, data on free energies of formation (refs. 11 and 12) indicate that the halogens are more reactive than their hydrogen halides and their use as ball-milling media could prove dangerous as a result of spontaneous, self-sustaining reactions between some of the halogens and the metal powders. The reactivity of halogens can be decreased by dissolving them in relatively nonreactive liquids. In this case ball-milling with halogens can probably be carried out safely, just as ball-milling nickel and copper with oxygen dissolved in water was shown to be safe in a previous investigation by the author (ref. 6).

Chemical analyses (other than halogens). - Comparison of the chemical analyses of ball-milled powders in table II with those of the as-received powders in table I shows that,

in addition to the halogens already discussed, iron, carbon, and nitrogen are also picked up by the powders during ball-milling. The iron pickup ranges from about 0.5 to 1.3 weight percent on an as-milled powder basis and comes from wear of the stainless-steel balls, cages, and mills used for milling. The carbon contents range from 230 to 1370 ppm, also on an as-milled powder basis. The nitrogen analyses of the as-milled chromium range from 81 to 248 ppm, which (on a chromium-content basis) represents from 1.4 to 4 times the nitrogen in the as-received chromium. The 280 ppm of carbon in the powders from run 7 (table II) is equivalent to 483 ppm on a nickel-content basis. The fact that this carbon content is smaller than the 1400 ppm for the as-received nickel (table I) is not considered significant because this latter value is a typical value from the supplier. Both the carbon and nitrogen pickups may come from the stainless steel picked up from balls, cages, and mills, from the hydrogen halides used as milling media, and from the glove-box atmosphere in which the powders were handled.

Reduction of Metal Halides Produced During Ball-Milling

The halogen content of the ground powders ranges from 25.4 to 45.9 weight percent, as already mentioned. These halogens must be removed before the milled powders are processed into consolidated products. The method used in this investigation for the removal of the halogens is reduction of the metal halides in high-purity hydrogen. The reduction process can be represented by the chemical equations (1) and (2) written in reverse (i. e. , hydrogen gas reacts with the metal halides to form hydrogen halide gases and solid metal). The rate of metal halide reduction depends on the temperature and on the nature of the metal halide. For this reason, before reducing the powders to be consolidated, some preliminary experiments were conducted in order to establish suitable temperature ranges within which the reduction could be carried out at reasonable rates.

Preliminary experiments on halogen removal. - The results of preliminary experiments designed to investigate the removal of the halogens in the milled powders as a function of temperature and time at temperature are shown in figures 9 and 10, respectively.

The plots of weight loss against reduction temperature (fig. 9) for HCl-, HBr-, and HI-milled chromium powders after 3-hour reductions at each temperature in pulsed hydrogen show that all three chromium halides can be reduced at temperatures above about 500° C. Above this temperature, reduction of the chromium halides occurs at a measurable rate. It is shown in figure 9 that the weight loss at a given temperature between about 500° and 750° C increases in the order HCl milled, HBR milled, HI milled.

As shown in the weight loss - time plot of figure 10 for the reduction of CrCl₃ in the HCl-milled powder at 625° C in pulsed hydrogen the rate of weight loss is practically

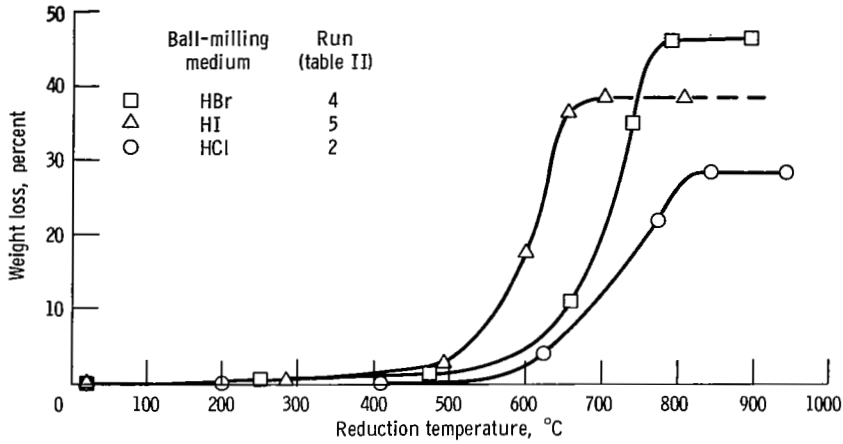

Figure 9. - Cumulative percent weight loss during hydrogen reduction of chromium powders obtained by ball-milling in hydrogen halides. Reducing conditions: approximately 10 grams of each powder reduced in purified hydrogen pulsating between 1.15 and 2.10 absolute atmospheres (1.16×10^5 and 2.12×10^5 N/m² abs); same powder charge was used for all runs with given type of powder; reduction time, 3 hours per run.

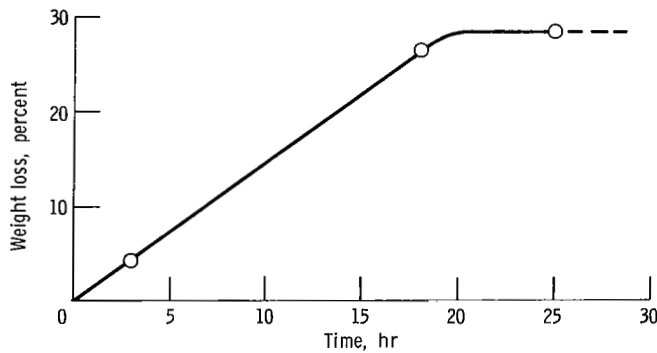

Figure 10. - Effect of reduction time on weight loss for chromium powder reduced in hydrogen at 625°C. Reducing conditions: approximately 10 grams of chromium powder from HCl milling run 2 (see table II); purified hydrogen pulsating between 1.15 and 2.10 absolute atmospheres (1.16×10^5 and 2.12×10^5 N/m² abs) at 60 pulses per hour.

constant to almost complete removal of the chlorine. The HBr- and HI-milled powders probably behave in a similar manner.

Reduction of halides in powders used for compaction and/or analysis. - The reducing temperature and time and the results of weight loss and chemical analysis of the hydrogen-treated powders are shown in table III. The after-reduction particle size of one of the HCl-milled chromium powders (run 2) is also included in this table. Reduction runs 8 and 9, also shown in table III, were carried out to determine the feasibility of reducing the pure metal halides, and the results are discussed in the section Reduction

of Chromic Chloride (CrCl_3) and Nickel Chloride (NiCl_2) in Hydrogen.

The reduction temperatures shown in table III were selected on the basis of the preliminary reduction runs. In general, reduction times were found to be a function not only of the reduction temperature but also of the amount of powder being treated. The time and temperatures shown in table III reflect adjustments made in these two variables as dictated by the amounts of powder being used in each run.

The weights lost by the milled powders during reduction (table III) are larger than the corresponding halogen contents from chemical analyses (table II). The probable reason for this difference is that, in addition to being reduced, the metal halides partially evaporate during cleaning. The fact that the milled chromium powders containing iodides (runs 5 and 6, table III) show the largest difference in these values supports this explanation, since iodides are in general more volatile than either the bromides or the chlorides (ref. 11).

As previously indicated, the amounts of halogens being removed during cleaning were monitored by weighing the powders at regular intervals during the run. This procedure, besides being time consuming, contributes to contamination of the powders with impurities (mainly oxygen and nitrogen) from the glove-box atmosphere. The fact that the same kind of hydrogen halide used for ball-milling is evolved on cleaning the milled powders in hydrogen could be used for monitoring the course of the cleaning runs. Among the possible monitoring methods (weight changes in an absorbent, passing the exhaust gases through a pH indicator, gas chromatography, etc.) gas chromatography is considered to be one of the most convenient, accurate, and sensitive. Preliminary experiments by the author showed that even when run at low sensitivity, a research gas chromatograph can detect 0.0001 cubic centimeter of a hydrogen halide. Hence, a 10-cubic-centimeter sample of exhaust gas from a retort would show the presence of as little as 10 ppm of hydrogen halides. With larger (or concentrated) samples even lower hydrogen-halide concentrations would be detectable. Actually, the average hydrogen-halide concentration during a cleaning run was calculated to be about 350 ppm. Hence, the end point of the reduction of metal halides with hydrogen should be readily detectable with a gas chromatograph.

Comparison of results for run 2 (chromium milled in HCl) in tables II and III shows that the 0.043-micrometer as-ball-milled chromium powder grew to 0.53-micrometer particle size after the hydrogen treatment at 673°C for 38 hours. This isolated determination of particle size of as-reduced powder was carried out to determine the extent to which the powders agglomerate during reduction. Quite probably the other hydrogen-treated powders also grew in size during reduction of the metal halide.

Chemical analyses for residual halogens in reduced powders. - Comparison of halogen contents of as-milled powders in table II with those of the as-reduced powders in table III shows almost complete reduction of metal halides. These amounts of halogens

are negligibly small, except for the powders made by milling in HBr (runs 4 and 7). The 500 and 2300 ppm of residual bromine in the powders from runs 4 and 7, respectively, may be a result of sintering during reduction. The 2300 ppm of bromine remaining in nickel (run 7) is relatively large probably because of the greater sinterability of nickel as compared with chromium. It is surmised that relatively high reduction temperatures (which increase sintering rates), such as used for run 4, or easily sintered powders, such as nickel in run 7, would tend to trap the metal halides between the sintering particles.

Chemical analyses for oxygen, nitrogen, carbon, and iron in reduced powders. -

The oxygen analyses data for the reduced powders in table III show that the chromium reduced in run 2 has 405 ppm of oxygen as compared with 104 ppm in the as-received chromium powder (table I). The amounts of oxygen from chemical analyses of runs 3 to 6 (table III) is even less than the oxygen (0.665 weight percent) put in the chromium as thoria (ThO_2). From these data, it cannot be ascertained whether or not chromic oxide (Cr_2O_3) impurities in chromium (or oxygen dissolved in chromium) are removed by the reducing treatment used in this investigation. On the other hand, the oxygen analyses data for nickel in tables I and II show that, despite the low reducing temperature used, some oxygen is removed from nickel by the cleaning treatment used in this investigation.

Calculations based on the nitrogen content of the as-milled chromium powders in table II and of the as-cleaned powders in table III show that during reduction runs 2 and 4 (table III) some nitrogen was removed from the powders. On the other hand, during cleaning runs 3, 5, and 6 (table III) the nitrogen content of the powders increased. The large variations in the amounts of nitrogen gained or lost by the powders preclude determining whether or not nitrogen was removed during hydrogen cleaning.

Comparison of the carbon analyses of cleaned powders in table III with those of the as-milled powders in table II reveals that the cleaned powders have lower carbon content than the as-milled powders. Calculations show that the amounts of carbon removed from the chromium powders during reduction runs 2 to 6 ranged approximately from 1/12 to 3/4 of the carbon in the as-milled powders. On the average, about 2/3 of the carbon was removed from these chromium powders. In contrast, only about 1/8 of the carbon was removed from the nickel from run 7, probably because of the low temperature (350°C) used.

The iron analyses on an as-cleaned powder basis are given in table III. These values were calculated from the iron analyses data in table II. For comparison purposes, the iron pickups as determined from the weight lost by balls, cages, and mills during ball-milling are also included in the same column of table III. These analyses of as-cleaned powders show that as much as 2 weight percent iron (or an equivalent of about 3 weight percent stainless steel) is picked up by the powders during ball-milling. The logical so-

lution to this iron-pickup problem is to use milling equipment made entirely from, or plated with, chromium.

Reduction of Chromic Chloride (CrCl_3) and Nickel Chloride (NiCl_2) in Hydrogen

Table III shows the chemical analyses and particle sizes of the chromium and nickel powders obtained by reduction of CrCl_3 and NiCl_2 , respectively, in purified, pulsating hydrogen. Reducing temperatures and times at temperature are also included in this table.

The chromium powder obtained (run 8) had a particle size of 0.78 micrometer, 0.457 weight percent oxygen, 200 ppm residual chlorine, and relatively small amounts of carbon (176 ppm) and nitrogen (149 ppm). The relatively large amount of oxygen in this powder probably originates in the raw CrCl_3 . The particle size of this powder is somewhat larger than that of the chromium obtained by milling and cleaning in run 2.

The data for nickel obtained by reduction of NiCl_2 (run 9, table III) show that this powder has a fairly small (0.35 μm) particle size, and only 870 ppm oxygen, 120 ppm carbon, 190 ppm sulfur, and 270 ppm residual chlorine. As far as the chemical analysis is concerned, this nickel powder compares favorably with that obtained by ball-milling and cleaning (run 7, table III).

The idea behind these halide reduction experiments was that, if these chlorides could be hydrogen reduced without excessive agglomeration and contamination, it should be possible to make dispersion strengthened alloys by direct ball-milling of halides with the dispersoid, followed by hydrogen cleaning of the powder mixture. This procedure would not require the somewhat hazardous use of hydrogen halides as milling media. From the results already discussed it appears that the idea is feasible, but it has two main drawbacks. The first drawback is the relatively long times (138 and 160 hrs for Cr and Ni, respectively) required for reduction of the chlorides. These are about 3 to 4 times the time required for cleaning the ball-milled powders. A second drawback is that some of the halides are fairly hygroscopic and must be protected from atmospheric moisture.

The reduction of chromium chlorides with hydrogen and some of the problems associated with this method of chromium production are discussed in the literature (refs. 13 and 14). The chromium powders produced in this investigation appear to be of about the same purity as the chromium spangles produced by the method of reference 10. It should be noted that, in the methods of chromium chloride reduction described in references 10 and 11, temperatures in excess of 800^o C are used, as contrasted with 675^o C used in this investigation. Considering the agglomeration of milled chromium powders during hydrogen treatments already discussed, the lower temperatures used in this investigation are preferred.

It is surmised that reduction of halides other than chlorides may yield results similar to those obtained by reducing the chlorides, or perhaps even better. This surmise is based on the fact that (from an interparticle spacing standpoint) the chromium powders obtained by ball-milling in HI produce better results than those ball-milled in HCl, as is pointed out in the section Advantages of Hydrogen Iodide Ball-Milled Material.

Isostatically Hot-Pressed Chromium-Thoria Alloys

Chemical analyses. - The chemical analyses of the Cr-ThO₂ compositions obtained by isostatic hot-pressing of the hydrogen-cleaned powders at 1093^o C and 747 atmospheres (757×10^5 N/m²) for 2 hours are listed in table IV. The volume percentages of ThO₂ and Cr₂O₃ in table IV were calculated from the oxygen and ThO₂ given by chemical analyses, on the assumption that the oxygen in excess of that in ThO₂ is in the form of Cr₂O₃. The sum of these two volume percentages of dispersoids is very close to four. The material from run 5 resulting from ball-milling in HI has the lowest calculated volume percentage of Cr₂O₃. The fact that this material was the one cleaned at the lowest temperature used for the Cr-ThO₂ materials in this investigation may have something to do with the low volume percentage of Cr₂O₃.

The amounts of ThO₂ ball-milled with the chromium powder were calculated to yield a final product containing 5.48 weight percent or 4 volume percent of ThO₂. Invariably, the amounts of ThO₂ given by chemical analyses (table IV) are smaller than the 5.48 weight percent added to the chromium. The differences between these two sets of values (5.48 wt. % - wt. % of ThO₂ from chemical analyses) are listed in table IV as weight percentages of ThO₂ lost on cleaning. The amounts of calculated ThO₂ lost ranged from 2.74 to 10.4 weight percent of the original ThO₂ added. Quite probably, the loss of ThO₂ occurred by formation of volatile thorium halides during the cleaning process. This loss is not considered detrimental because it can be easily compensated for by increasing the amounts of ThO₂ in the ball-mill powder charge.

The oxygen contents of the consolidated samples listed in table IV are invariably larger than those of the corresponding, as-cleaned powders (table III). It is surmised that the oxygen analyses obtained from the consolidated samples are more accurate than those obtained from the powder samples. The reason for this would be that some of the powder in the samples listed in table III could be lost (by being blown out of the capsules) during the analyses.

Microstructures and interparticle spacings. - Electron photomicrographs of the as-consolidated, chromium-thoria alloys listed in table IV are shown in figures 11(a) to (d). All these photomicrographs show dispersoid particles (ThO₂ with some Cr₂O₃, see table IV) in the chromium matrix. The pits in some of these photomicrographs are pull

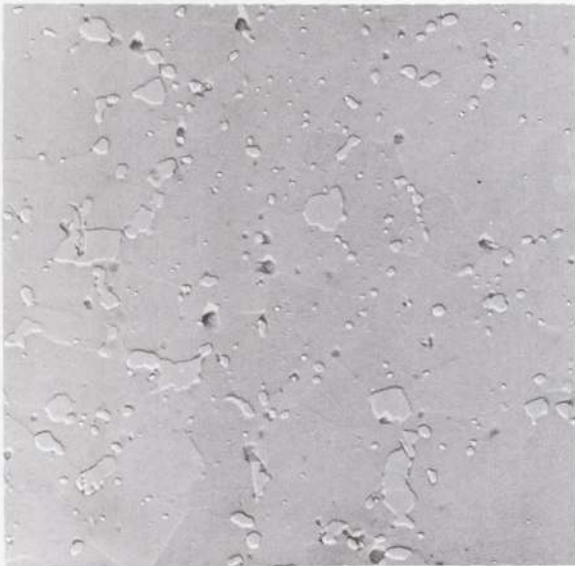

(a) Ball-milled in HCl; run 3, tables II and III; interparticle spacing, 3.5 micrometers.

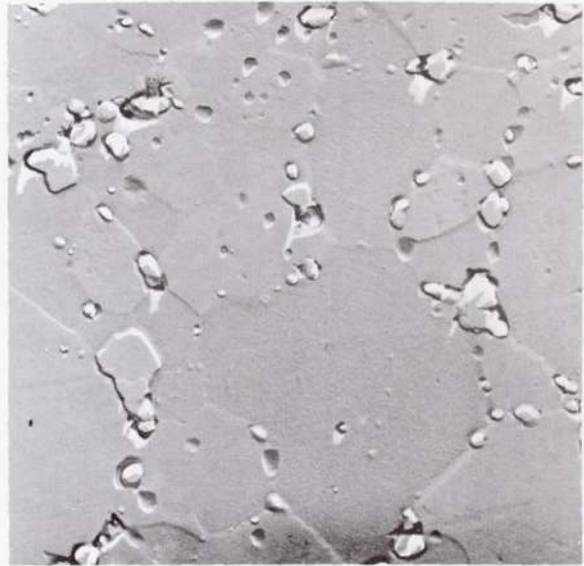

(b) Ball-milled in HBr; run 4, tables II and III; interparticle spacing, 6.5 micrometers.



(c) Ball-milled in HI; run 5, tables II and III; interparticle spacing, 2.1 micrometers.

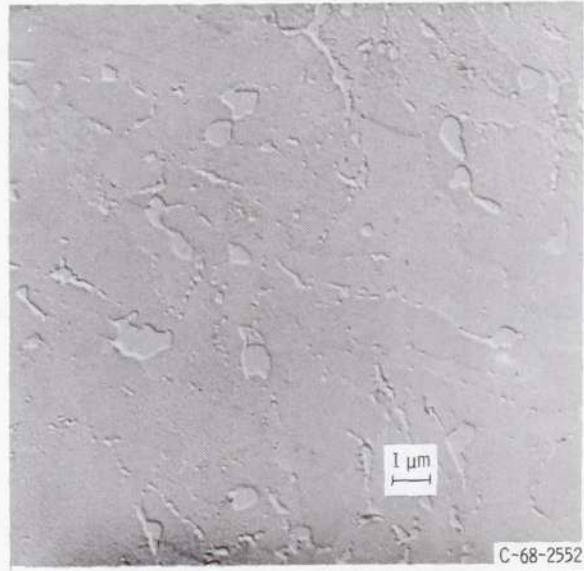

(d) Ball-milled in HI; run 6, tables II and III; interparticle spacing, 2.4 micrometers.

Figure 11. - Electron photomicrographs of chromium with 4 volume percent thorium dioxide.

outs and not pores, as revealed by examination of unetched samples. Most of the dispersoids segregated to the grain boundaries between elongated grains. Also the etchant appears to have attacked preferentially the chromium surrounding the particles. This effect is particularly noticeable in figure 11(b).

The interparticle spacings (IPS) of the as-consolidated Cr-ThO₂ alloys listed in table IV were obtained by counting particles intercepted by straight lines in the photomicrographs shown in figure 11. The IPS values so obtained are also listed in table IV. The material with the smallest IPS (2.1 micrometers) was obtained by ball-milling in HI (milling run 5). The low IPS (as compared with those of the rest of the samples in table IV) may be a result of the fact that this material (sample 5) has the lowest calculated amount (0.10 volume percent) of Cr₂O₃ among the four as-hot-pressed samples. The second-best material obtained in this investigation has an IPS of 2.4 micrometers and was also obtained by ball-milling in HI (run 6). Improved ball-milling techniques (longer times, different ball mix, etc.) and lower hydrogen reduction temperatures (as low as about 525° C) can be expected to further decrease the IPS of these Cr-ThO₂ alloys. Lower hot-pressing temperature and/or shorter time at temperature can also be expected to decrease the IPS, other things being equal.

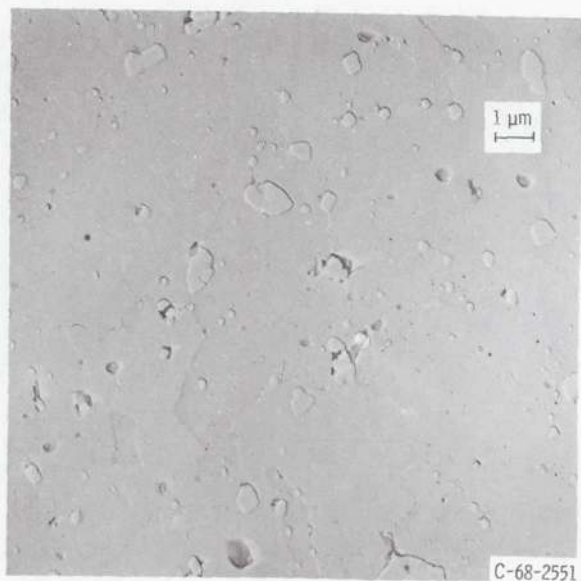

Figure 12. - Electron photomicrograph of chromium with 4 volume percent thorium dioxide after stabilizing anneal of 100 hours at 1318° C. Milled in HI; run 5, tables II and III; interparticle spacing, 5.2 micrometers.

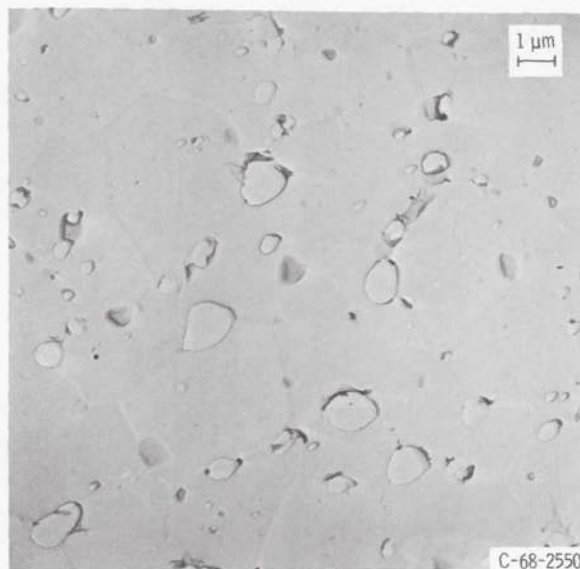

Figure 13. - Electron photomicrograph of chromium with 4 volume percent thorium dioxide after stabilizing anneal of 1 hour at 1450° C. Milled in HI; run 5, tables II and III; interparticle spacing, 6.5 micrometers.

Stability Anneals

Only the 2.1-micrometer-IPS, as-consolidated material (run 5, table IV) was tested for thermal stability. The electron photomicrograph of a specimen of this material annealed for 100 hours at 1318^o C is shown in figure 12. The electron photomicrograph of another specimen of the same material annealed for 1 hour at 1450^o C is shown in figure 13. Both photomicrographs show the dispersoid (originally ThO₂ with small amounts of Cr₂O₃, see table IV) imbedded in the chromium matrix and pits resulting from pull outs. Most of the agglomerated dispersoids are now located at triple points, and the originally elongated chromium grains (see fig. 11(c)) became equiaxed and grew in size. These microstructures are similar to those of similarly annealed, dispersion strengthened chromium-molybdenum alloys reported in the literature (ref. 9).

The IPS of the specimen annealed for 100 hours at 1318^o C is 5.2 micrometers, and that of the sample annealed for 1 hour at 1450^o C is 6.5 micrometers.

Advantages of Hydrogen Iodide Ball-Milled Material

The material obtained by ball-milling in HI and cleaned at low temperature (610^o C) is superior to the rest of the materials listed in table IV. This is evident from the particle size and halogen pickup data in table II, the chemical analyses for residual halogen in table III, the chemical analyses for ThO₂ and oxygen in table IV, and most of all from comparison of IPS (table IV and figs. 11 to 13). From the safety standpoint, the fact that the iodides are the least reactive of the halides and that (liquid) hydrogen iodide is bottled under relatively low pressure (6.45 atm gage or 6.55×10⁵ N/m² gage) renders the process of milling in HI more attractive than milling in other hydrogen halides.

CONCLUDING REMARKS

Some results from this investigation are considered to be of general applicability. The results show that it was possible to comminute chromium and nickel to very fine particle sizes by ball-milling in reactive hydrogen halide gases. On grinding, the metals reacted with the gaseous milling media and large percentages were converted to the corresponding metal halides. The process is similar to that described in a previous investigation by the author (ref. 6) in which it was postulated that comminution of most ductile metal and alloy powders to fine sizes requires their reacting with the grinding media. Similar results may also be obtainable by using the pure halogens or halogens diluted in nonreactive liquids as grinding media.

Since this investigation was intended to prove feasibility, no attempt was made to optimize the various processing steps towards obtaining alloys with still smaller IPS. Quite probably this IPS can be decreased (with constant amount of dispersoid) by

- (1) Lowering the reduction temperature
- (2) Decreasing the particle size of the ball-milled powders (longer milling time, different ball mix, etc.)
- (3) Using higher-purity raw materials and milling media
- (4) Hot-pressing at lower temperatures and/or for shorter time at temperature

The feasibility of reducing nickel and chromium chlorides to the corresponding metals containing low residual chlorine was also demonstrated. From this it is surmised that it may be possible to produce dispersion strengthened nickel and chromium (or their alloys) by ball-milling their halides and the dispersoid, followed by hydrogen reduction of the halide in the resulting powder mixture. Most of these halides, however, are hygroscopic and for this reason special processing techniques would be required for their preparation and handling to prevent their contamination with (atmospheric) water.

SUMMARY OF RESULTS

The main purpose of the present investigation was to determine the feasibility of producing chromium with finely divided thorium dioxide, suitable for dispersion strengthening, by ball-milling in hydrogen halide gases. In addition, the feasibility of producing fine nickel powder by ball-milling in hydrogen bromide and of reducing chromium and nickel chlorides in hydrogen was investigated. The results obtained can be summarized as follows:

1. Submicron-size powders ranging in size from 0.04 to 0.09 micrometer were produced by ball-milling chromium and chromium - thorium dioxide (Cr-ThO_2) powders in hydrogen halides. From 11 to 18.9 percent of the chromium was converted to the halide in the grinding process.
2. Nickel was comminuted to the finest-particle-size powder (0.023 micrometer) obtained in this investigation, by ball-milling in hydrogen bromide. In the grinding process, 26.5 weight percent nickel was converted to nickel bromide (NiBr_2).
3. The ground Cr-ThO_2 , chromium, and nickel powders containing large percentages of halides resulting from the reaction with the milling media were subjected to reduction treatments in high-purity hydrogen under pulsating pressure. The resulting, cleaned Cr-ThO_2 powders ground initially in hydrogen iodide contained 6 ppm, or less, iodine, less than 50 ppm chlorine, and 500 ppm bromine, respectively. The cleaned chromium and nickel powders contained less than 200 ppm chlorine and 2300 ppm bromine, respectively. During this reducing treatment some agglomeration of the metal powders occur-

red, as shown by the fact that the 0.04-micrometer, as-milled chromium grew to 0.53 micrometer during the treatment.

4. Despite the agglomeration and increase in size of the powders during the reducing treatments, an interparticle spacing (IPS) of 2.1 micrometers was obtained in a Cr-ThO₂ alloy after isostatic hot-pressing of one of the cleaned powders. This powder had been obtained by ball-milling in hydrogen iodide. The other Cr-ThO₂ materials had IPS in the range of 2.4 to 6.5 micrometers.

5. The IPS of the 2.1-micrometer, Cr-ThO₂ alloy increased to 5.2 and 6.5 micrometers after stabilizing anneals of 100 hours at 1318^o C and 1 hour at 1450^o C, respectively. The reason for this instability is not known.

6. Clean, 0.78-micrometer chromium and 0.35-micrometer nickel powders containing 270 ppm, or less, chlorine were also obtained by reducing chromic chloride (CrCl₃) and nickel chloride (NiCl₂) powders in pulsating hydrogen at 675^o and 358^o C, respectively.

Lewis Research Center,
National Aeronautics and Space Administration,
Cleveland, Ohio, July 18, 1968,
129-03-01-05-22.

REFERENCES

1. Cremens, Walter S.: Use of Submicron Metal and Nonmetal Powders for Dispersion Strengthened Alloys. Ultrafine Particles. William E. Kuhn, ed., John Wiley & Sons, Inc., 1963, pp. 457-478.
2. Cochardt, A. W.: Some Estimates of the Thermal Stability of Dispersion-Hardened Alloys. J. Metals, vol. 9, 1957, pp. 434-437.
3. Bunshah, R. F.; and Goetzel, C. G.: A Survey of Dispersion Strengthening of Metals and Alloys. New York Univ. (WADD TR 59-414), Mar. 1960.
4. Arias, Alan: Investigation of Thermal Shock Resistance of Zirconia with Metal Additions. NASA TN D-2464, 1964.
5. Weeton, John W.; and Quatnetz, Max: Cleaning and Stabilization of Dispersion Strengthened Materials. Presented at the AIME Conference on Oxide Dispersion Strengthening, Bolton Landing, N. Y., June 27-29, 1966.
6. Arias, Alan: The Role of Chemical Reactions in the Mechanism of Comminution of Ductile Metals into Ultrafine Powders by Grinding. NASA TN D-4862, 1968.

7. Googin, John M.: Sintering Tungsten Powder to High Density. Patent No. 3, 109, 735, United States, Nov. 5, 1963.
8. Orr, Clyde, Jr.; and Dallavalle, J. M.: Fine Particle Measurement. The MacMillan Co., 1959, ch. 7.
9. Allen, R. E.: Dispersion-Strengthened Chromium Alloys. Rep. 66FPD284, General Electric Co. (NASA CR-85907), Oct. 20, 1966.
10. Hodgman, Charles D.; Weast, Robert C.; and Selby, Samuel M., eds.: Handbook of Chemistry and Physics. 41st ed., Chemical Rubber Publ. Co., 1959.
11. Kubaschewski, O.; and Evans, E. LL.: Metallurgical Thermochemistry. Third ed., Pergamon Press, 1958.
12. Wicks, C. E.; and Block, F. E.: Thermodynamic Properties of 65 Elements - Their Oxides, Halides, Carbides, and Nitrides. Bulletin No. 605, U.S. Bureau of Mines, 1963.
13. Schneider, Kurt: Metallic Chromium from Chromium Chloride. Patent No. 2, 246, 386, United States, June 17, 1941.
14. Campbell, Ivor E.; and Oxley, Joseph H.: Reducing Chromium Chloride to Metal with Hydrogen in a Fluidized Bed. Patent No. 3, 043, 679, United States, July 10, 1962.

TABLE I. - CHARACTERIZATION OF RAW MATERIALS

Material ^a	Form	Grade	Purity, percent	Manufacturer's specifications or chemical analyses
Cr	Electrolytic flake, hammer-milled to -30 mesh (5 μ m average size)	High purity	99.5 (min.)	Oxygen, 104 ppm ^b ; C, 97 ppm ^b ; N, 85 ppm ^b ; Fe, 0.33 wt. %
Ni	Powder, 1.2 μ m	(c)	99.7 ^d	Oxygen, 0.14 wt. %; C, 0.14 wt. %; Fe, 0.008 wt. %
CrCl ₃	Powder	High purity	99.5 ^d	(c)
NiCl ₂	Powder	Technical	(c)	(c)
ThO ₂	Colloidal powder, 0.0050 to 0.0150 μ m	High purity	99.9 (min.)	S, 100 ppm; Ca, 350 ppm (max.); Fe, 10 ppm (max.); Si, 60 ppm (max.); Na, 100 ppm (max.); all other elements < 50 ppm total
HCl	Under pressure in steel tanks	Technical	99.0 (min.)	HCl (liquid phase), 99.5 wt. % (min.); hydrocarbons, 0.5 wt. % (max.); water, 0.01 wt. % (max.); CO ₂ , 0.01 wt. % (max.); inert materials, 0.1 wt. % (max.)
HBr	Under pressure in steel tanks	(c)	99.8 (min.)	HBr, 99.8 wt. % (min.); HCl, 0.20 wt. % (max.)
HI	Under pressure in steel tanks	(c)	98.0 (min.)	HI, minimum liquid purity of 96 percent (impurities consist of iodine in liquid phase and hydrogen in gas phase)
A	Under pressure in steel tanks	High purity	99.9 (min.)	O ₂ < 2 ppm ^b ; CO, 200 ppm ^b ; CO ₂ , 40 ppm ^b ; H ₂ , 300 ppm ^b ; H ₂ O, 4 ppm ^b ; N ₂ , 14 ppm ^b

^aName of manufacturer will be supplied upon request.

^bAnalysis from commercial laboratory.

^cUnknown or not determined.

^dNominal analyses.

TABLE II. - CHEMICAL ANALYSES AND PARTICLE SIZES OF BALL-MILLED POWDERS

Run	Ball charge	Milling time, hr	Powder charge		Milling media				Chemical analyses of ball-milled powders				Weight percentage of original metal converted to halide on ball milling	Specific surface area, m ² /g	Particle size, μm
			Powder	Weight, g	Gas	Absolute gas pressure		Calculated percentage of halogen used	C, ppm	N, ppm	Halogen, wt. %	Fe, wt. %			
						Atm	N/m ²								
(a)								(b)					(c)		(d)
1	B	384	Cr	150.0	A	10	10.1×10 ⁵	0	(e)	(e)	(e)	(e)	(e)	0.94	0.59
2	C	425	Cr	150.0	HCl	7.1 (max.)	7.2	26.6	400	248	Cl, 27.9	(e)	18.9	12.9	.043
3	C	384	Cr	141.8	HCl	8 (max.)	8.1	25.3	980	91	Cl, 25.41	0.45	17.6	6.16	.090
			ThO ₂	8.24											
4	C	384	Cr	141.8	HBr	7.9 (max.)	8.0	45.4	230	150	Br, 45.92	.80	19.5	6.64	.084
			ThO ₂	8.24											
5	C	384	Cr	141.8	HI	5.2 (max.)	5.3	35.1	560	83	I, 34.93	1.28	11.6	12.2	.046
			ThO ₂	8.24											
6	D	240	Cr	141.8	HI	6.1 (max.)	6.2	(f)	1370	81	I, 41.94	.57	15.6	8.29	.067
			ThO ₂	8.24											
7	E	285	Ni	150.0	HBr	7.8 (max.)	7.9	36.4	280	(e)	Br, 41.95	.68	26.5	24.34	.023

^aBall charges: B, 400 balls of 12.6 mm diam (3420 g total); plus cage. C, 400 balls of 12.6 mm diam and 400 balls of 6.3 mm diam (3845 g total); plus cage. D, 400 balls of 12.6 mm diam and 800 balls of 6.3 mm diam (4270 g total); no cage. E, Same as C but no cage.

^bCalculated from pressure data. Weight percentage based on total weight of ball-milled powders.

^cWeight percentage of metal converted to halide on ball-milling, calculated from results of chemical analyses of halogens in this table. Halides assumed for computations were CrCl₃, CrBr₃, CrI₂, and NiCl₂.

^dDetermined by equation: Particle size (μm) = 4/ρS where ρ is density (g/cm³) of material and S is specific surface area (m²/g). Equation developed in ref. 2.

^eNot determined.

^fNot calculated because of defective pressure gage.

TABLE III. - PULSATING HYDROGEN REDUCTION OF BALL-MILLED POWDERS AND OF CHROMIC CHLORIDE (CrCl_3) AND NICKEL CHLORIDE (NiCl_2)

[Hydrogen pressure pulsed between 0.15 and 1.1 atm (0.15×10^5 and 1.1×10^5 N/m²), 60 pulses/hr, hydrogen flow, 0.142 m³/hr, for all runs.]

Cleaning run	Material cleaned	Cleaning conditions		Material weight loss on reduction, percent	Chemical analyses							Specific surface area, m ² /g	Particle size, μm (b)	Figure showing photomicrograph of hot-pressed specimen
		Temperature, °C	Time, hr		Oxygen, wt. %	Carbon, ppm	Nitrogen, ppm	Halogens, ppm	Other					
									Element	Wt. %	Wt. % (a)			
2	Cr from milling run 2	673	38	29.15	0.0405	350	248	Cl, ND ^c (<200)	Fe	-----	0.68	1.05	0.53	----
3	Cr-ThO ₂ from milling run 3	696	33	26.3	^d .540	370	234	Cl, ND ^c (<50)	Fe	0.603	.67	(e)	(e)	11(a)
4	Cr-ThO ₂ from milling run 4	755	37	46.4	^d .541	390	170	Br, 500	Fe	1.48	1.55	(e)	(e)	11(b)
5	Cr-ThO ₂ from milling run 5	610	57	38.4	^d .424	330	190	I, 6	Fe	1.965	----	(e)	(e)	11(c)
6	Cr-ThO ₂ from milling run 6	666	50.5	48.2	^d .389	640	200	I, 4	Fe	.982	0.98	(e)	(e)	11(d)
7	Ni from milling run 7	350	51	40.4	.0825	420	(e)	Br, 2300	Fe	1.17	1.02	(e)	(e)	----
8	CrCl ₃	675	138	67.3	.457	176	149	Cl, 200	(e)	(e)	(e)	0.71	0.78	----
9	NiCl ₂	358	160	56.7	.087	120	(e)	Cl, 270	S	0.019	----	1.29	.35	----

^aValues estimated from weight lost by balls and cages during ball-milling.

^bParticle size determined from equation (ref. 2): Particle size (μm) = $4/\rho S$, where ρ is density of material in g/cm³ and S is specific surface in m²/g.

^cNot detected.

^dFour volume percent ThO₂ (in original powder charge) is equivalent to 0.665 weight percent oxygen.

^eNot determined.

TABLE IV. - CHEMICAL ANALYSES AND INTERPARTICLE SPACINGS OF ISOSTATICALLY HOT-PRESSED MATERIALS

[Hot-pressing conditions, 1093° C and 747 atm (757×10^5 N/m²) for 2 hr in He.]

Material history		As-compacted designation	Chemical analysis, wt. %		ThO ₂ lost on cleaning (based on 5.48 wt. % added), wt. %	Calculated dispersoid, ^a vol. %		Annealing conditions (in He)		Interparticle spacing, ^b μm	Figure showing electron photomicrograph
Milling run	Cleaning run		Oxygen	ThO ₂		ThO ₂	Cr ₂ O ₃	Temperature, °C	Time, hr		
3	3	3	0.759	4.91	10.4	3.57	0.73	(c)	(c)	3.54	11(a)
4	4	4	.676	5.14	6.21	3.75	.23	(c)	(c)	6.53	11(b)
5	5	5	.658	5.33	2.74	3.88	.10	(c)	(c)	2.10	11(c)
5	5	5	.658	5.33	2.74	3.88	.10	1318	100	5.2	12
5	5	5	.658	5.33	2.74	3.88	.10	1450	1	6.5	13
6	6	6	.674	4.95	9.66	3.60	.33	(c)	(c)	2.4	11(d)

^aVolume percentage of ThO₂ calculated from ThO₂ given by chemical analyses in this table. Cr₂O₃ volume calculated, on assumption that oxygen in excess of that required to form ThO₂ was tied up as Cr₂O₃, from chemical analysis data in this table.

^bCalculated from electron photomicrographs by linear intercept method.

^cNot annealed.