

# UC Berkeley

## HVAC Systems

### Title

Field study of the impact of a desktop task/ambient conditioning system in office buildings

### Permalink

<https://escholarship.org/uc/item/8x98n5hj>

### Authors

Bauman, Fred  
Carter, T.  
Baughman, A.

### Publication Date

1998

Peer reviewed

# Field Study of the Impact of a Desktop Task/Ambient Conditioning System in Office Buildings

**Fred S. Bauman, P.E.**  
Member ASHRAE

**Thomas G. Carter, P.E.**  
Student Member ASHRAE

**Anne V. Baughman**  
Student Member ASHRAE

**Edward A. Arens, Ph.D.**  
Member ASHRAE

## ABSTRACT

*A field study was carried out to assess the impact of installing a desktop task/ambient conditioning (TAC) system at 42 selected workstations within three San Francisco office buildings occupied by a large financial institution. In this study, field measurements, including subjective surveys and physical monitoring, were performed both before and after the TAC system installation to evaluate the impact of the TAC system on occupant satisfaction and thermal comfort, as well as the thermal environments within the office buildings. For comparative purposes within each building, a control group, consisting of workers who did not receive a desktop TAC unit, was studied concurrently. During the follow-up field tests, performed three months after the TAC system installation, measurements were repeated under three different room temperature setpoint conditions (normal, set-up, and set-down) to investigate the ability of the occupants to use the desktop TAC units to control their local environment in response to a wider range of ambient temperatures.*

*Survey results show that among the six building assessment categories investigated, installation of the desktop TAC system provided the largest increases in overall occupant satisfaction for thermal quality, acoustical quality, and air quality. In terms of specific environmental factors, increased occupant satisfaction levels among the TAC group were strongly significant in comparison to changes within the control group for both temperature and temperature control. A large majority of the workers in the control group indicated a preference for higher air movement at operative temperatures of 73°F (23°C) and above. The percentage preferring higher air movement within the TAC group was significantly lower. Workers in the TAC group had the ability to use their TAC units to adjust the air movement in their workstations in response to changes in the ambient temperature. Over the*

*range of operative temperatures covered by this field study, air movement preference and thermal sensation votes by workers in the control group indicated that they were more than twice as sensitive to changes in temperature as those in the TAC group.*

## INTRODUCTION

In late 1995, as part of an effort to improve the quality of indoor environments within their office facilities, the corporate real estate group of a large financial institution decided to conduct a pilot study of a commercially available desktop task/ambient conditioning (TAC) system by installing desktop TAC units at selected locations in three of its San Francisco office buildings. The authors were brought in to perform field measurements in these three buildings both before and after the TAC system installation to evaluate the impact of the TAC system on occupant satisfaction and thermal comfort, as well as the thermal environments within the office buildings. The measurement methods used in this field study included (1) occupant surveys, (2) short-term physical measurements of environmental conditions at individual workstations, (3) long-term trend measurements of temperature, humidity, and air quality conditions, and (4) network-based monitoring of occupant use patterns of the desktop TAC system controls.

The first baseline field measurements were made in March 1996. The 42 desktop TAC units were installed in the three buildings during the first two weeks of April. The follow-up field measurements were completed in July, three months after the TAC system installation. During the follow-up field tests, measurements were repeated under three different room temperature setpoint conditions: normal, set-up, and set-down. Resources did not allow us to conduct a more ideal field study, which would have included additional measure-

---

**Fred S. Bauman** is a research specialist, **Thomas G. Carter** and **Anne V. Baughman** are graduate student researchers, and **Edward A. Arens** is a professor and director of the Center for Environmental Design Research at the University of California, Berkeley.

ments to determine if the change in occupant satisfaction would be sustained over a longer time period.

This paper summarizes some of the key findings from the field study. For full details of the study and its conclusions, refer to Bauman et al. (1997).

### Desktop Task/Ambient Conditioning System Description

A sketch of a typical desktop TAC system installation in a workstation is shown in Figure 1. The desk-mounted unit supplies conditioned or recirculated air at desktop level. It uses a self-powered mixing box that is hung in the back or corner of the knee space of the desk and is connected by flexible duct to two supply nozzles on the top of the desk. The supply vents may be rotated 360 degrees in the horizontal plane and contain outlet vanes that are adjustable  $\pm 30$  degrees in the vertical plane. The mixing box uses a small variable-speed fan to pull conditioned air from either an underfloor air supply plenum (as indicated) or down from the ceiling from vertical ducts connected to an overhead air distribution system

(this is the duct configuration used in two of the three office buildings in this study). Using damper control, the fan can also pull recirculated room air from the knee space through a fiber particle filter. Both supply air and recirculated room air are drawn through a charged fiber filter. The relative fractions of supply air and recirculated air are controlled by dampers on each of these two lines. For installations providing conditioned supply air to the desktop supply units, the main supply line damper is never allowed to close completely, thus ensuring the delivery of some fresh ventilation air at all times. An alternative configuration provides no connection to the building's ventilation system and therefore delivers only recirculated air through the desktop supply nozzles.

The key occupant-control component of the TAC unit is a desktop control panel containing adjustable sliders controlling the speed of the air emerging from the vents, its temperature (produced by adjusting the ratio of supply to recirculated air), the temperature of a 175 W radiant heating panel located in the knee space, the dimming of the occupant's task light, and a white noise generator in the unit that issues a rushing sound through the supply vents. The control panel also contains an infrared occupancy sensor that shuts the unit off when the workstation has been unoccupied for a few minutes and turns it back on when the occupant returns.

Each desktop TAC unit is capable of providing approximately 12 cfm to 150 cfm (6 L/s to 70 L/s) of total supply air from the nozzles. For desktop units with the primary air inlet connected to the building's ventilation system, the TAC unit is designed to deliver at least 12 cfm (6 L/s) of primary air to satisfy minimum ventilation requirements, even when its internal fan is turned off. In operation, 55°F (13°C) air is provided by a variable-air-volume ventilation system to the TAC unit, with desk-level outlet temperatures in the range of 65°F (18°C). The primary air supplied to the TAC unit may be a mixture of outside air and recirculated air, depending on the central system.

Previous laboratory studies indicate that the desktop TAC units are capable of controlling local thermal conditions over a wide range, allowing office workers the opportunity to fine-tune the local workstation environment to their individual comfort preferences (Arens et al. 1991; Bauman et al. 1993). At larger air supply volumes, the TAC units were able to provide true task ventilation (i.e., increased ventilation at the location of the occupant), with lower ages of air at the breathing level in the workstation compared to that of the air leaving the room through the return grill (Faulkner et al. 1993). In other words, the

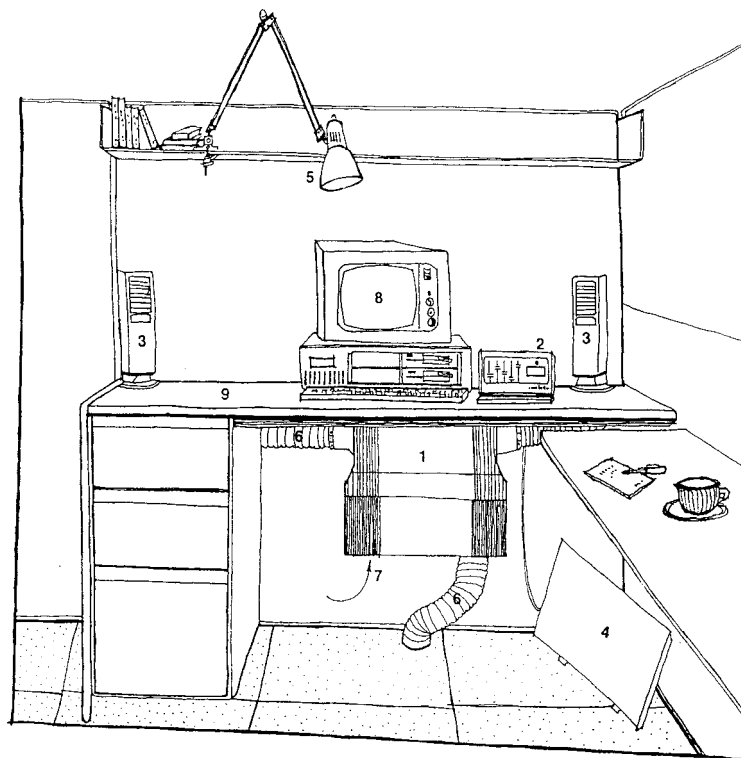

1. desktop supply module
2. desktop control panel
3. desktop supply nozzle
4. radiant heating panel
5. task light
6. flexible supply duct
7. recirculated room air
8. personal computer
9. desk

**Figure 1** Desktop task/ambient conditioning (TAC) system.

TAC unit changes the air more frequently at the breathing level than the overall air exchange rate of the room. This is desirable, as improved ventilation is provided where it is needed.

The first large installation (370 units) of this desktop TAC system was in a newly designed office building in Wisconsin. The building was fully occupied in July 1991. Post (1993) describes the new building and its intelligent building features that allowed it to lower operating costs and improve workplace productivity and still cost less than conventional buildings. Researchers carried out a study in which they used an existing measure to track the productivity of more than 100 employees for 27 weeks before and for 24 weeks after they moved into the new building containing desktop TAC units. The project investigators concluded that the TAC units increased worker productivity by 2.8% (Kroner et al. 1992). Despite the difficulty in making this kind of estimate, the results are encouraging.

Occupant comfort and energy use of the desktop TAC system were investigated as part of a field study of a small demonstration office containing four such units (Bauman and McClintock 1993). Monitored occupancy patterns showed that the use of occupancy sensors is very effective at limiting excessive energy use associated with the desktop TAC units and other workstation-based equipment that can be turned off when the workstation is unoccupied. In a second field study using the same demonstration office, a total of eight desktop units were installed and monitored, and the air distribution system was reconfigured to allow switching between the TAC system and a conventional ceiling-based air distribution system (Akimoto et al. 1996). The study found that when the wall thermostat was maintained at a warm condition near the upper limit of the ASHRAE thermal comfort zone (79°F [26°C]), the desktop TAC system was able to keep the average temperatures in the workstations 2°F - 4°F (1°C - 2°C) lower than the thermostat temperature and at least 2°F (1°C) lower than that maintained by the overhead air distribution system under similar operating conditions.

In another study, annual building energy simulations using the DOE-2 computer program investigated the energy performance of a new prototypical office building in two California climates: Fresno and San Jose (Bauman et al. 1994). The simulations compared three different TAC system configurations (including the desktop system) vs. a base case building consisting of a reasonably efficient standard overhead air distribution system with an air-side economizer. The simulation results showed that, in comparison to the base case, the desktop TAC system in a San Jose office building could save annually as much as 18% of the cooling energy, 18% of the distribution (fans and pumps) energy, 10% of the total electricity, and 9% of the total electricity cost.

A recently published design guide (Bauman and Arens 1996) presents engineering and application guidelines for

TAC systems, including the desktop system of the present study. A well-designed TAC system should take maximum advantage of the potential improvements in thermal comfort, ventilation performance, indoor air quality, and occupant satisfaction and productivity while minimizing energy use and costs.

## FIELD STUDY METHODOLOGY

### Description of Test Sites and Subjects

Three office buildings in San Francisco were designated as test sites for this field study. Within each building, two distinct groups of subjects were selected to participate in the study: (1) a TAC group, consisting of workers who originally occupied workstations in which desktop TAC units were to be installed, and (2) a control group, defined as a group of workers in the same building having similar work conditions to the TAC group but who would not be receiving TAC units in their workstations. By collecting and comparing measurement data from these two groups, it was anticipated that the impact of installing the desktop units could be most meaningfully evaluated.

A total of 42 TAC units were installed in the three buildings, so members of the three TAC groups included the 42 workers occupying these workstations at the time of our first baseline field measurements in March 1996. Within each building we also selected at least 10 to 12 workers for the control group. This enabled us to accumulate a control database based on a number of subjects similar to the TAC groups. The three building test sites and the selected groups of participants are described briefly below.

In Building A, 18 workers in a northwest-facing open plan office space on the 22nd floor were selected to have desktop TAC units installed in their workstations. In this building and in Building B, modifications were made to the existing overhead air distribution system to allow each desktop TAC unit to be connected via a vertical six-inch supply air duct. All ceiling diffusers positioned over the TAC group area were capped off, although perimeter slot diffusers were left in place to handle the more variable perimeter heating and cooling loads. Air supply to the adjacent spaces on the 22d floor continued to be provided by the existing overhead air distribution system.

The control group in Building A was selected from workers located in a similar office space on the 17th floor, which also bordered along the northwest glazing of the building to match the solar exposure of the TAC group. This office was conditioned by a conventional overhead air distribution system.

The TAC group in Building B consisted of 15 workers located in a large northwest-facing open plan office space on the 4th floor. These workers were located in two of the six rows of workstations in this space. The control group was selected from workers in the same space occupying workstations outside of these two rows.

The TAC group in Building C consisted of nine workers in a south-facing open plan office space on the 2d floor. For this installation, the desktop TAC units were not connected to the building's overhead air distribution system. Each TAC unit, therefore, delivered only recirculated room air through its desktop supply nozzles. The control group was selected from workers in an adjacent and similar office space on the same floor.

### Occupant Survey

A survey was used to assess the response of the occupants to the quality of the physical environment at their work location, in particular, their response to the installation of the desktop TAC units. The survey was adapted from a previously developed questionnaire as part of an indoor environmental

quality assessment system (Baughman et al. 1995). The survey consisted of two types of questions: (1) background questions, which addressed some general information and the occupants' overall perception of their work environment over the past two months, and (2) questions on environmental conditions right now, which provided a snapshot of how the occupants perceived their work environment by asking how they felt at the time they were filling out the survey. Figure 2 presents two example pages from the occupant survey, one from the background section and one from the section on current environmental conditions. For a complete listing and discussion of the occupant survey, please see Bauman et al. (1997).

**Background Questions.** The major portion of the background section of the survey asked the occupants for their opinions of their work environment with regard to six major

**a.**

**Work Area Satisfaction**

How satisfied are you with the following attributes of your work environment related to THERMAL COMFORT . . .

**Is the temperature . . . ?**  
(circle one response for each row)

too cool: never sometimes often  
comfortable: never sometimes often  
too warm: never sometimes often

**How would you rate the temperature control within your work area ?**

highly variable  
 moderately variable  
 moderately stable  
 very stable

**Is the air movement . . . ?**  
(circle one response for each row)

too low: never sometimes often  
comfortable: never sometimes often  
too high: never sometimes often

**How would you rate the overall impact of the THERMAL COMFORT in your work area on your ability to do your work effectively?**

very negative impact      no impact      very positive impact

**How satisfied are you in general with the temperature ?**

very dissatisfied      very satisfied

**How satisfied are you in general with the temperature control in your work area ?**

**How satisfied are you in general with the level of air movement ?**

**b.**

**Environmental Conditions RIGHT NOW**

**How would you describe the brightness level of your work area ?**

very bright  
 moderately bright  
 moderately dim  
 very dim

**How would you describe the air movement within your work area ?**

very high level of air movement  
 moderately high level of air movement  
 moderately still  
 very still

**How would you describe the humidity within your work area ?**

very humid  
 moderately humid  
 slightly humid  
 slightly dry  
 moderately dry  
 very dry

**How acceptable is this brightness level ?**

very unacceptable      very acceptable

**How acceptable is this air movement ?**

very unacceptable      very acceptable

**Would you prefer:**

more air movement  
 no change  
 less air movement

**How acceptable is this humidity ?**

very unacceptable      very acceptable

Figure 2 a) Example survey page: background survey; b) Example survey page: environmental conditions right now survey.

building assessment categories: spatial layout, office furnishings, thermal comfort, lighting quality, acoustical quality, and air quality. The standard metric used for most questions was the level of satisfaction on a six-point scale, ranging from very satisfied (6) to very dissatisfied (1). Within each assessment category, three specific environmental factors were addressed. The average of the scores from these three factors made up the overall occupant satisfaction rating for that category. Also, for each major assessment category, the occupants were asked to rate the overall impact of each on their ability to perform their work effectively.

Because the background questions addressed overall impressions of the occupants' work environment, they were asked one time at the beginning of the study (March 1996) to establish baseline opinions and responses and a second time near the end of the study (July 1996) to assess any changes in opinions three months after the installation of the desktop TAC system.

### Questions on Environmental Conditions Right Now.

After the background section, the occupants were asked for their feelings and level of acceptability at the time they were filling out the survey regarding seven environmental conditions: brightness, air movement, humidity, ventilation quality, odors, noise, and thermal environment. They were also asked a short series of questions describing their recent activity level and food and beverage consumption. The survey concluded with three open-ended questions asking the occupants for additional comments.

The subjective data from the "environmental conditions right now" section of the survey could be directly related to the physical data collected immediately thereafter at the workstation by the portable measurement cart, as described below. This section of the survey was generally administered at the same time as the background section and at other selected times when we wanted to correlate the occupants' current subjective feelings with physical data we were collecting during the three testing periods (normal, set-up, and set-down) of the post-installation field test.

## Physical Measurements

**Short-Term Measurement of Workstation Environments.** Physical measurements of the local workspace environment were made using our existing portable measurement system. These measurements were generally completed as part of visits to individual workstations during which the occupants also answered survey questions about their "environmental conditions right now," described above. The data were used to correlate the occupants' subjective responses with their actual physical environment and to characterize the individually controlled workstation environments produced by the desktop TAC units.

Figure 3 shows a sketch of the battery-powered portable measurement cart, which collected a complete set of detailed measurements characterizing the local environment using an automated approach. The response time and accuracy of the

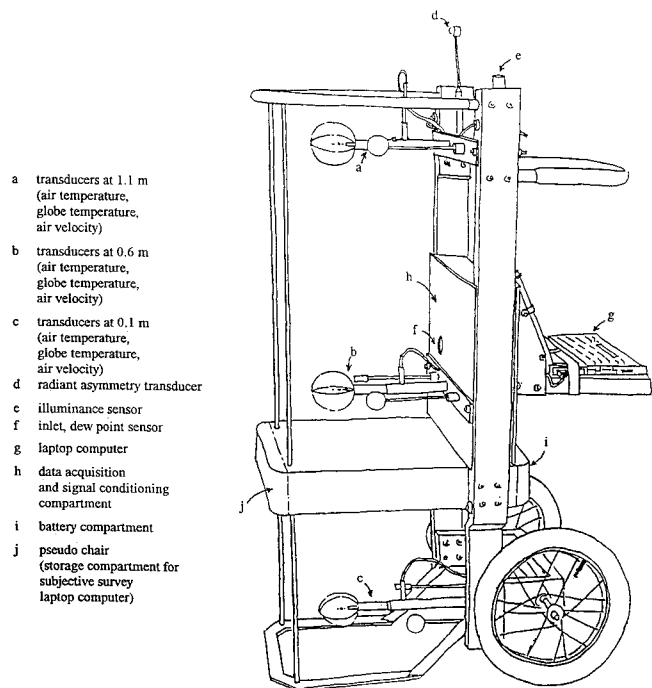

Figure 3 Portable measurement cart.

measurement cart's sensors, as well as their placement at three heights above the floor (4 in. [0.1 m], 2 ft [0.6 m], and 3 ft, 7 in. [1.1 m]), were all chosen to meet the requirements specified in recognized indoor environmental standards (ASHRAE 1992; ISO 1985). This system has been used in several previous field studies of office environments (Benton et al. 1990; Bauman et al. 1993; de Dear and Fountain 1994a). Data are collected for thermal (air temperature, globe temperature, air velocity and turbulence intensity, humidity, and radiant temperature asymmetry) and other environmental parameters (illumination, CO<sub>2</sub> concentration, and sound level).

**Long-Term Measurement with Distributed Sensors and Data Loggers.** Several miniature, battery-powered, portable data loggers were used to collect data on temperature, humidity, and CO<sub>2</sub> level at regular intervals throughout the study period (March through July 1996) at various locations at each site. These measurements provided continuous trend data to complement the "snapshot in time" data provided by the portable measurement cart. The trend data were used to ensure that abnormal temperature, humidity, or CO<sub>2</sub> levels were not unexpected factors in influencing occupant satisfaction and comfort responses during the different test periods.

**Desktop TAC System Monitoring Network.** Using a network communication capability provided by the desktop TAC system, a monitoring network was set up at each test site to record data on individual occupant use patterns of the desktop unit controls. All desktop units at each test site were networked together via an RS-485 communication link and monitored from a single compatible host location. A modem connected to the host in each building allowed remote access via phone lines to download data each night to our university

laboratory. Within each desktop TAC unit, the status of several control parameters were monitored: (1) discharge (mixed) air temperature (a built-in sensor measures the temperature of the air in the main supply duct leaving the under-desk unit), (2) discharge air temperature setpoint, (3) radiant heater setpoint, (4) fan speed setpoint, (5) task light setpoint, (6) white noise setpoint, and (7) occupancy sensor status.

### Field Measurement Procedures

The procedures used to administer the occupant surveys and take physical measurements were similar to those used in our previous field work. After first checking on availability, a researcher distributed the paper survey to the subject. The subject completed the survey while sitting at his/her workstation, taking about 15 minutes to do so. Afterwards, the subject was asked to leave the workstation for about five minutes while the portable measurement cart was positioned at the work location in front of the desk and recorded physical measurements of the environmental conditions to which the subject had just responded.

The first baseline field measurements were completed in March 1996. The post-installation field measurements were completed in July, three months after installation of the desktop TAC system. Typically, two days were required to carry out the measurements in all three buildings. During these follow-up field tests, measurements were repeated under three different room temperature setpoint conditions to observe how the occupants would respond with their TAC units to different thermal environments.

July 10 - 11, 1996: This period was “normal” in that the historical space temperature setpoints were used.

July 24 - 25, 1996: This period was considered to be a “set-up” period where the space temperature setpoint was set up to try to achieve a higher (warmer) than normal space temperature.

July 31 - Aug. 1, 1996: This period was considered to be a “set-down” period where the space temperature setpoint was set down to try to achieve a lower (cooler) than normal space temperature.

To allow occupants to adapt to the different ambient conditions, the set-down and set-up periods began on Monday morning and continued through the site visits (until Wednesday or Thursday). This gave occupants at least two days’ exposure to the different conditions prior to being surveyed. In all cases, temperatures, though cooler or warmer, were kept within limits that could conceivably be experienced by an office worker. Table 1 summarizes the average space temperatures maintained during occupied hours (8:00 a.m. - 5:00 p.m. on weekdays), as measured by the portable temperature loggers.

From Table 1 we see that not all set-ups and set-downs of ambient temperature were successful. In some cases, limitations of the HVAC system and the mixing of air from adjacent zones not included in the study prevented the desired conditions from being achieved. The set-up in Building A turned out to be actually a small set-down, while the set-down turned out to be significant. In Building B, a moderate set-up and set-down were achieved. In Building C, we were able to achieve a significant set-up due to high internal heat loads from the large amount of new computer equipment that was being tested in the office during that week. The set-down achieved in Building C, however, was very small.

### RESULTS

Presented below is a selection of key findings from the analysis of the collected survey and physical measurement data. Most of the results described here emphasize how the workers responded to temperature and air movement. For a full description, refer to Bauman et al. (1997).

#### Occupant Survey

**Work Area Satisfaction.** The following results are based on responses to questions in the background section of the occupant survey in which the occupants were asked to respond based on their perception of the environment over the previous two-month period. The statistical analysis was primarily based on a comparison of the pre-installation (baseline) survey (March 1996) and the post-installation survey (July 1996) for

**TABLE 1**  
**Average Test Site Temperatures (Weekdays, 8:00 a.m. - 5:00 p.m.)**

Building	Group	Baseline: March (°C / °F)	Post-TAC Normal: July 10-11 (°C / °F)	Post-TAC Set-Up: July 24-25 (°C / °F)	Post-TAC Set-Down: July 31-Aug. 1 (°C / °F)
A	TAC	22.8 / 73.0	22.3 / 72.1	21.9 / 71.4	21.0 / 69.8
	Control	22.9 / 73.2	22.7 / 72.9	N/A	N/A
B	TAC	22.3 / 72.1	23.1 / 73.6	23.8 / 74.8	22.4 / 72.3
	Control	22.3 / 72.1	23.1 / 73.6	23.8 / 74.8	22.4 / 72.3
C	TAC	23.2 / 73.8	21.9 / 71.4	24.9 / 76.8	21.7 / 71.1
	Control	22.8 / 73.0	22.3 / 72.1	N/A	N/A

each group (TAC and control). By comparing responses from the same individuals before and after installation of the desktop TAC system, individual differences could be factored out. Inclusion of the control group in the database accounted for any response changes due to environmental factors not directly caused by the installation of the TAC units. For example, seasonal differences may allow changes in the use of an outside air economizer (affecting the ventilation rate), changes in humidity levels, or changes in lighting levels due to natural light.

The background section of the survey was administered once in March and once again during the first test period of July when room setpoint temperatures were maintained at their normal levels (no set-up or set-down). During the baseline field test, we initially surveyed 42 occupants in the TAC group and 40 occupants in the control group between all three buildings. Primarily because of personnel changes, occupant unavailability, and relocations, we were only able to obtain surveys during the first post-installation field test from 28 members of the original TAC group and 25 members of the original control group. Unless otherwise noted, the results presented below are based on this set of 53 occupants for which both baseline and post-installation surveys were

obtained. To maintain the largest possible database for statistical significance, results from all three building test sites were analyzed together.

Figure 4 summarizes and compares the overall occupant satisfaction ratings for the six building assessment categories from the baseline (March) and post-installation (July) surveys for both the TAC and control groups. As seen in Figure 4, the assessment categories that showed the largest increases in occupant satisfaction after installation of the desktop TAC units were thermal quality (+0.84), acoustical quality (+0.58), and air quality (+0.46). The magnitudes of these increases are all larger than the corresponding differences observed for the control group. It is not surprising that these three categories also all represent environmental factors addressed by the control capabilities of the desktop TAC unit. It is also noteworthy that the satisfaction ratings from both the March and July surveys are higher for all six categories for the TAC group in comparison to the control group, indicating that the members of the TAC group are, in general, more satisfied with their work environment both before and after installation of the TAC system. It is reasonable to hypothesize that given this higher level of satisfaction, there would be less room for

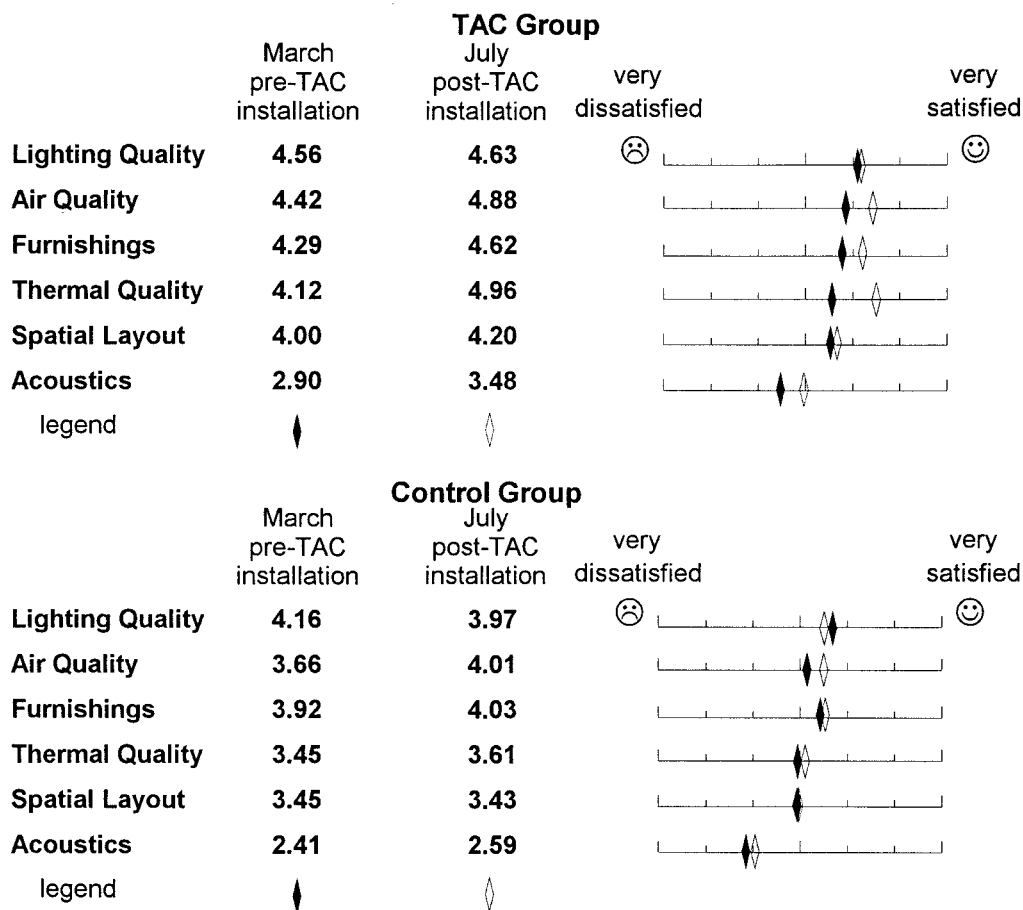

**Figure 4** Overall occupant satisfaction ratings.



improvement after installation of the TAC system, making these findings conservative.

The statistical significance of the change in occupant satisfaction from baseline to post-installation conditions were characterized by using t-test analysis. Table 2 summarizes the results in which for each environmental factor, the average change (increase or decrease) in occupant satisfaction from baseline to post-installation conditions for the TAC group is compared with that for the control group. In this analysis, a p-value of less than 0.05 is defined as having a strong level of significance (i.e., less than a 5% probability that the difference occurred by chance). A p-value between 0.05 and 0.10 is defined as having some level of significance (5%-10% probability that the difference occurred by chance). The tables also show whether a one- or two-tailed t-test was used for the values presented. One-tailed tests were used for environmental factors that were expected to demonstrate increased levels of occupant satisfaction after the desktop TAC units were installed. These were factors in the thermal, air, lighting, and acoustical quality categories for the TAC group, all of which are influenced by the environmental control capabilities of the desktop TAC unit.

**Thermal quality.** Detailed occupant satisfaction results for thermal quality are presented in Figure 5 for the TAC group and Figure 6 for the control group. In both figures, side-by-

side histograms are used, allowing easy comparison of the baseline (March) and post-installation (July) survey results. The histograms show the percent occupant response binned according to the six-point satisfaction scale. Some of the specific questions were asked in a previous ASHRAE-sponsored field study that included 300 subjects from ten office buildings in the San Francisco Bay area (Schiller et al. 1988). This large background database is also shown on the histograms when available to allow a benchmark comparison with these office buildings. Table 3 summarizes some additional results associated with Figures 5 and 6. For each environmental factor and data set (TAC, control, background), the table lists the mean satisfaction ratings for each survey and the percent dissatisfied (defined as those respondents who indicated they were either moderately or highly dissatisfied [range of 1-2 on scale]).

The overall rating for thermal quality is based on the satisfaction ratings for the three environmental factors: temperature, temperature control, and air movement. (Note that a complete listing of all 18 environmental factors, three for each of the six assessment categories, included in the background section of the survey are listed in Table 2.) Thermal quality received the highest net increase and the highest overall satisfaction rating of 4.96 after the installation of the desktop TAC system (see Figure 4). Table 3 indicates that

**TABLE 2**  
**Statistical Comparison of Change in Occupant Satisfaction**  
**Between Baseline and Post-Installation Surveys for TAC and Control Groups**

Assessment Category	Environmental Factor	P-Value	1- or 2-Tailed	Level of Significance
Thermal Quality	Temperature	0.046	1	Strong
	Temperature control	0.020	1	Strong
	Air movement	0.087	1	Some
Air Quality	Ventilation	0.203	1	
	Odors	0.737	2	
	Humidity	0.792	2	
Lighting Quality	Lighting level	0.075	1	Some
	Computer screen	0.094	2	Some
	Light from window	0.367	2	
Acoustical Quality	Background noise	0.099	1	Some
	Distracting noises	0.085	1	Some
	Conversational privacy	0.091	1	Some
Spatial Layout	Space available	0.130	2	
	Spatial privacy	0.516	2	
	Ease of interaction	0.957	2	
Office Furnishings	Comfort of chair	0.839	2	
	Comfort of other furn.	0.421	2	
	Colors/textures	0.267	2	

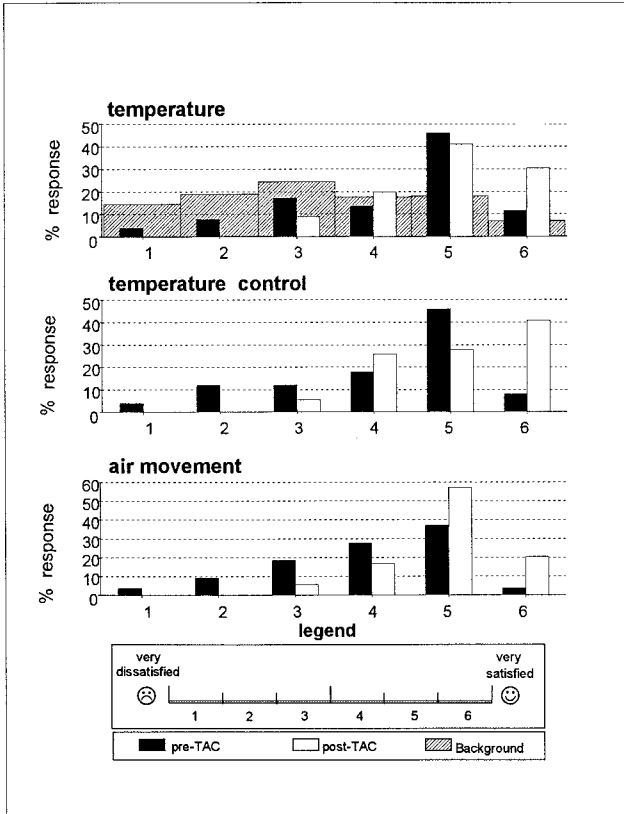

Figure 5 Occupant satisfaction, thermal quality: TAC group.

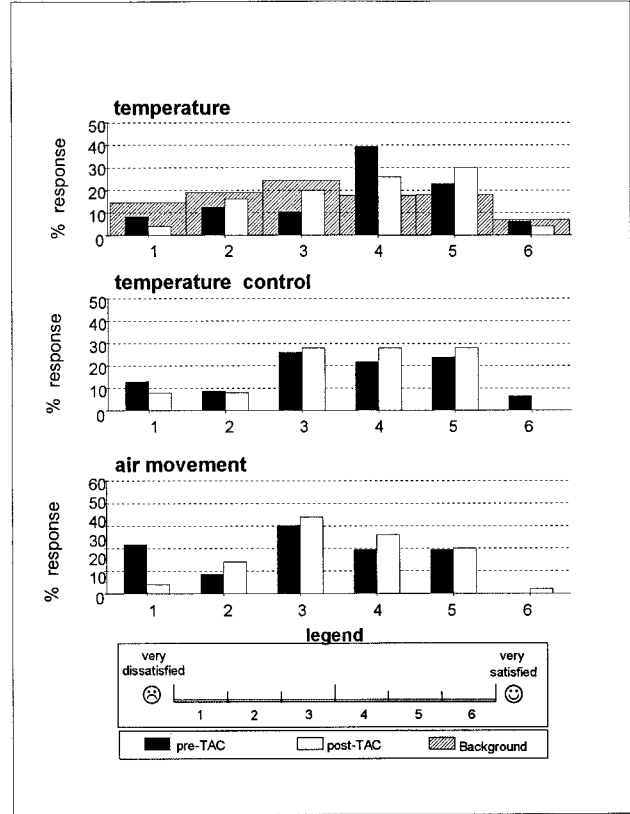

Figure 6 Occupant satisfaction, thermal quality: control group.

there is a large increase in mean ratings for all three of these factors within the TAC group (+0.7 for temperature, +0.9 for temperature control, and +0.9 for air movement). The t-test statistics show that these increased occupant satisfaction levels are strongly significant for temperature and temperature control and somewhat significant for air movement in compar-

ison to the control group (Table 2). Figure 4 also shows that the overall rating for thermal quality in the control group changes by only 0.16 between the March and July surveys (3.45 vs. 3.61). Differences between satisfaction ratings in the control group for each of the three environmental factors are also relatively small (-0.1 for temperature, -0.1 for temperature

TABLE 3  
Occupant Satisfaction: Thermal Quality

Group	Environmental Factor	Pre-TAC		Post-TAC	
		Mean Rating	Percent Dissatisfied	Mean Rating	Percent Dissatisfied
TAC Group	Temperature	4.2	11%	4.9	0%
	Temperature control	4.1	16%	5.0	0%
	Air movement	4.0	13%	4.9	0%
Control Group	Temperature	3.8	21%	3.7	20%
	Temperature control	3.5	22%	3.6	16%
	Air movement	3.1	30%	3.5	18%
Background	Temperature	3.3	33%		
	Temperature control	N/A	N/A		
	Air movement	N/A	N/A		

control, and +0.4 for air movement). The somewhat larger increase in satisfaction rating for air movement within the control group accounts for the higher p-value and reduced significance observed for that environmental factor in Table 2.

As shown in Figure 5, for all three environmental factors, this increase is characterized by a noticeable increase in the number of occupants indicating that they are very satisfied (bin 6 on scale) and a complete elimination of occupants indicating that they are either moderately or very dissatisfied (bins 1 and 2 on scale). The “0% dissatisfied” result for all three thermal factors (Table 3) suggests that practically all complaints related to thermal issues will be avoided for these occupants with the desktop TAC system in place. In comparison to the background data set shown on the temperature histogram, the office buildings receive a much higher occupant satisfaction rating within the TAC group for both baseline and post-installation surveys. Despite the relatively lower ratings for the control group, the buildings still achieved a higher score than the background data set in the temperature category (Table 3).

**Air quality.** The overall rating for air quality is based on satisfaction ratings for the three environmental factors: ventilation (perception of stuffiness), odors, and humidity. In the July post-installation survey, air quality along with thermal

quality were rated as the top two categories by the TAC group. This is an important result as it runs contrary to the common trend among many recent field studies that have found thermal and air quality issues to usually be among the lowest rated categories for occupant satisfaction (e.g., see Schiller et al. [1988] and Baughman et al. [1995]). Among the three environmental factors within the air quality category, ventilation received the highest increase of +0.7 in comparison to the change of +0.3 for the same factor for the control group. The t-test statistics show that none of the environmental factors in the air quality category have changes in occupant satisfaction levels that are significantly higher in comparison to the corresponding changes within the control group (Table 2). In the case of ventilation, which is expected to be improved with localized ventilation from the desktop TAC units, the rather large increase in satisfaction for the control group accounts for this result.

**Environmental Conditions Right Now.** Figures 7 and 8 present thermal comfort results from the section of the survey in which the occupants were asked for their feelings and level of acceptability at the time they were filling out the survey. Results are shown for the baseline (March) survey and the “normal” post-installation survey (first July survey), with Figure 7 showing results for the TAC group and Figure 8

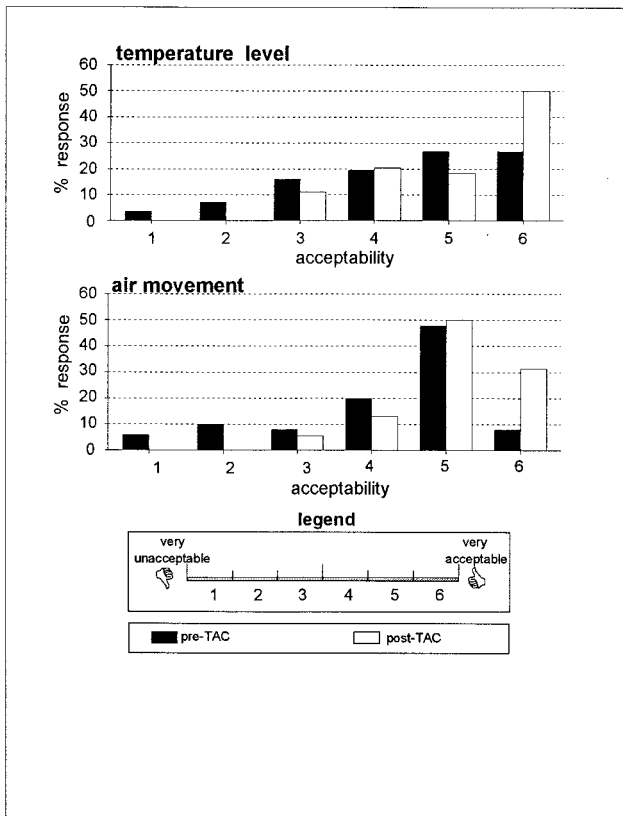

Figure 7a Acceptability at time of measurement: TAC group.

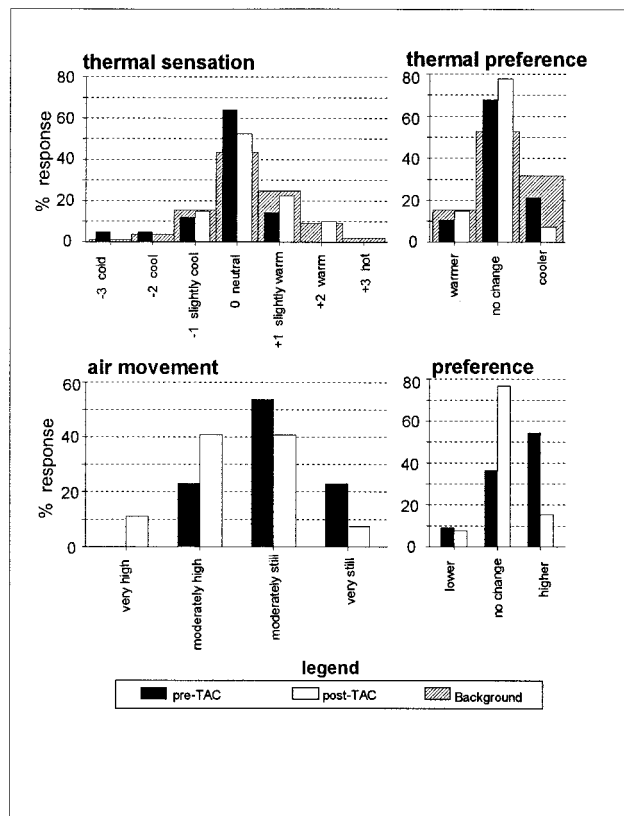
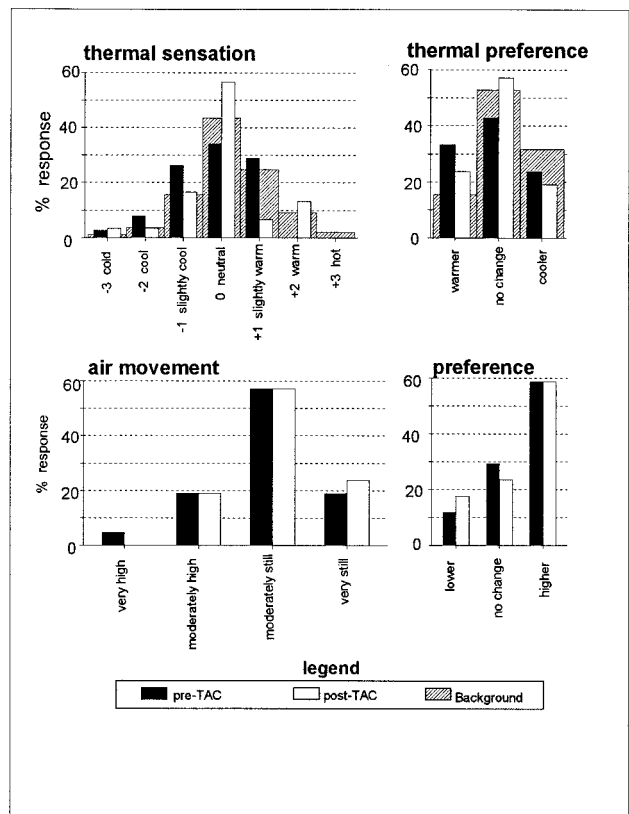
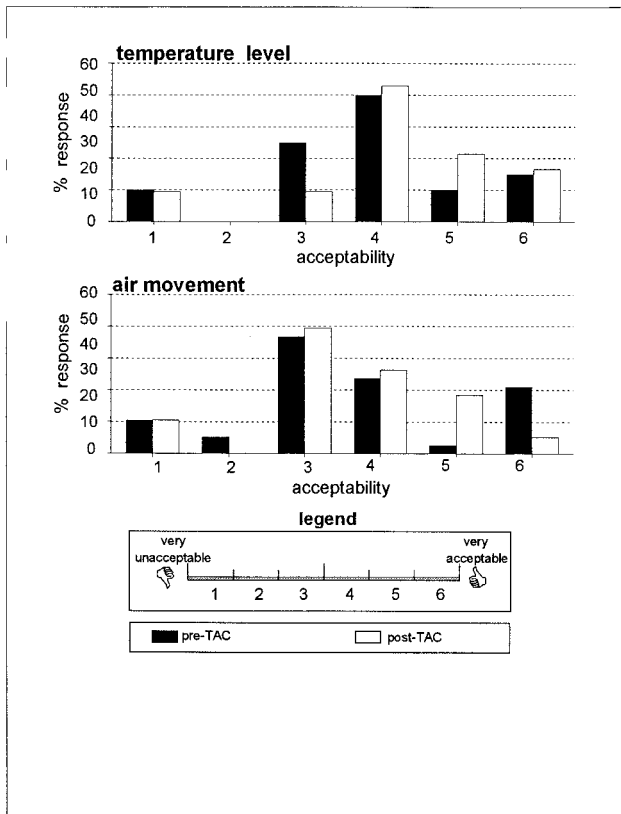

Figure 7b Environmental perception at time of measurement: TAC group.



**Figure 8a** Acceptability at time of measurement: Control group.

**Figure 8b** Environmental perception at time of measurement; Control group.

showing results for the control group. Table 4 summarizes some additional results associated with Figures 7 and 8, including mean acceptability rating, percent unacceptable, and average measured temperature and air velocity. The changes observed between the baseline and post-installation surveys are very similar to the trends found in the occupant satisfaction results (discussed previously).

**TAC group.** Substantial increases in the mean acceptability rating are found for both temperature level and air movement for the TAC group after the desktop TAC units have been installed. The thermal sensation results (Figure 7b) indicate that even though there were about 10% fewer respondents in the post-installation survey who felt their thermal sensation was neutral, about 10% more respondents preferred

**TABLE 4**  
**Acceptability and Environmental Perceptions: Thermal Quality**

		TAC Group		Control Group		Background
		Pre-TAC	Post-TAC	Pre-TAC	Post-TAC	
Temperature Acceptability	Mean rating	4.4	5.1	3.9	4.2	N/A
	% Unacceptable	11%	0%	10%	10%	N/A
Average Measured Temperature	(°C)	22.9	22.7	22.6	22.9	23.0
	(°F)	73.2	72.9	72.7	73.2	73.4
Air Movement Acceptability	Mean rating	4.2	5.1	3.7	3.6	N/A
	% Unacceptable	16%	0%	16%	11%	N/A
Average Measured Air Velocity	(m/s)	0.08	0.11	0.08	0.09	0.08
	(fpm)	16	22	16	18	16

to have no change in their thermal environment. This thermal preference result is directly related to a larger than 10% reduction in occupants wishing to be cooler, presumably because of the increased cooling capability of the desktop TAC system airflow. The average measured temperature at the workstations (Table 4) was slightly cooler during the post-installation survey (72.9°F [22.7°C]) than the baseline survey (73.2°F [22.9°C]) and the background dataset (73.4°F [23.0°C]). The post-installation air movement results show that the respondents perceive their air movement to be higher than during the baseline survey, as expected. This is reflected in the average measured velocity, which increases from 16 fpm to 22 fpm (0.08 m/s to 0.11 m/s). Air movement preference also shows a dramatic decrease in those wanting higher air movement, as it drops from 54% in the baseline survey to only 15% in the post-installation survey.

**Control group.** Mean acceptability ratings for the control group showed only slight changes between the baseline (March) and post-installation (July) surveys for temperature level and air movement. The thermal sensation and thermal preference results in Figure 8b indicate that, in comparison to the background dataset, more people thought the conditions were slightly cool and would prefer to be warmer for both surveys. This finding is further supported by the average measured temperature at the workstations, which was 72.7°F (22.6°C) during the March survey, 73.2°F (22.9°C) during the July survey, and 73.4°F (23.0°C) for the background dataset. For air movement, nearly 80% of the respondents in the control group perceived it to be moderately still or very still for both surveys. Unlike the TAC group, which showed a significant change between surveys, almost 60% in both surveys indicated a preference for higher air movement. With no local air supply available to members of the control group, this is not a surprising result and is similar to findings from many other field studies in office buildings with conventional overhead air distribution systems. Average measured air velocities from both surveys were nearly identical to each other and to that of the background dataset.

## Thermal Sensation

Subjects were asked during the “environmental conditions right now” portion of the survey to indicate their thermal sensation on the standard seven-point scale, ranging from -3 to +3 and corresponding to the range from cold to hot. By plotting these subjective responses vs. operative temperature (as measured by the portable measurement cart at each subject’s workstation), we investigated the sensitivity of thermal sensation to variations in temperature. These data were analyzed by grouping together individual thermal sensation votes into half-degree bins of operative temperature and then calculating the mean thermal sensation for that group of responses, as shown in Tables 5a and 5b. A linear regression line, weighted by the number of subjects within each bin, was then fitted to these mean thermal sensation values. The results are presented in Figures 9a (SI units) and 9b (I-P units) for all July test periods and for all three buildings. By including the normal, set-up, and set-down test periods, a wider range of operative temperatures achieved during this field study were available for analysis. Individual data points that formed the basis for the calculation of mean thermal sensation in Figure 9 included all valid workstation visits for which there existed both subjective survey results for “environmental conditions right now” and physical measurements of the local workstation environment. The results were separated for comparison into the TAC group and the control group. The TAC group consisted of 54 workstation visits (observations); the control group consisted of 60 observations. For each group, the mean thermal sensation values (“observed”) and the best-fit weighted regression line are shown.

The regression lines indicate that workers in the control group (slope = 0.891, p-value = 0.029) were more than twice as sensitive to changes in temperature as those in the TAC group (slope = 0.405, p-value = 0.011). Single-tail tests were used since it is expected that mean thermal sensation increases with operative temperature—i.e., the slope is positive. For the control group, a 1.8°F (1°C) change in operative temperature

**TABLE 5a**  
**Frequency Distribution of Thermal Sensation: TAC Group**

T <sub>OP</sub> (°C)	T <sub>OP</sub> (°F)	Sample Size	Average Thermal Sensation	Thermal Sensation Votes						
				-3	-2	-1	0	1	2	3
21.5	70.7	3	-0.50	-	-	2	1	-	-	-
22.0	71.6	10	-0.80	-	2	2	4	1	-	-
22.5	72.5	13	-0.23	-	1	3	10	-	-	-
23.0	73.4	13	-0.31	-	1	5	4	3	-	-
23.5	74.3	11	0.09	-	-	1	6	2	1	-
24.0	75.2	1	1.00	-	-	-	-	1	-	-
24.5	76.1	2	0.50	-	-	-	1	1	-	-
25.0	77.0	1	0.00	-	-	-	1	-	-	-

**TABLE 5b**  
**Frequency Distribution of Thermal Sensation: Control Group**

T <sub>OP</sub> (°C)	T <sub>OP</sub> (°F)	Sample Size	Average Thermal Sensation	Thermal Sensation Votes						
				-3	-2	-1	0	1	2	3
21.5	70.7	-	-	-	-	-	-	-	-	-
22.0	71.6	2	-2.50	1	1	-	-	-	-	-
22.5	72.5	30	-0.23	2	2	7	12	5	2	-
23.0	73.4	20	-0.05	-	3	2	10	3	2	-
23.5	74.3	3	0.67	-	-	-	2	-	1	-
24.0	75.2	4	0.75	-	-	1	1	1	-	1
24.5	76.1	1	1.23	-	-	-	-	1	-	-
25.0	77.0	-	-	-	-	-	-	-	-	-

corresponded to nearly a one unit (0.89) change in mean thermal sensation. It is interesting to note that these results are very similar to the findings of a recent ASHRAE research project

(RP-884) that assembled a very large, high-quality database from thermal comfort field experiments worldwide (de Dear and Brager 1998). By comparing results for centrally heated/air-conditioned buildings (no individual control) and naturally ventilated buildings (some individual control), they observed that the thermal sensation votes from occupants in the centralized HVAC buildings were also about twice as sensitive to temperature variations compared to occupants in the naturally ventilated buildings.

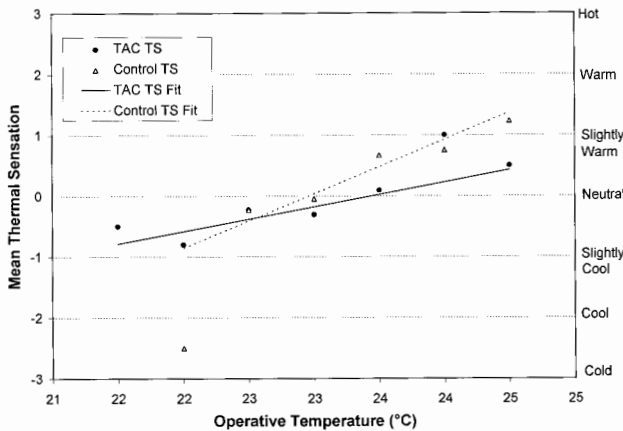

**Figure 9a** Mean binned thermal sensation votes: TAC group vs. control group, all buildings, July 1996 (SI).

Qualitatively, the results described here suggest that the individual thermal control capabilities of the TAC unit allow a larger percentage of TAC subjects to maintain comfortable conditions over a wider range of ambient temperatures. However, due to a lack of observations at extremes in operative temperature, the standard errors on the slope estimates are relatively high. Testing the hypothesis that the control group slope is significantly larger than the TAC group (i.e., the difference in slope does not occur by chance) suggests there is a 20% probability that the difference in slopes occurs by chance (single-tail p-value = 0.20).

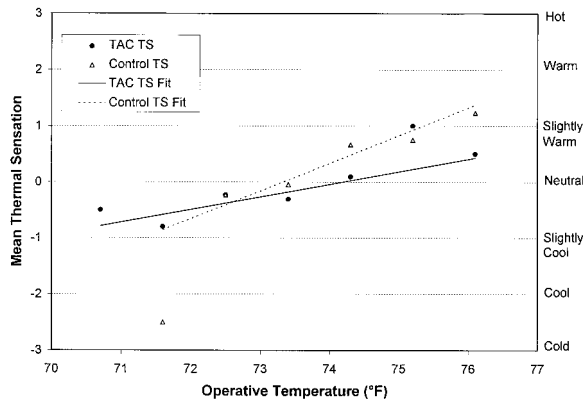

**Figure 9b** Mean binned thermal sensation votes: TAC group vs. control group, all buildings, July 1996 (I-P).

### Air Movement Preference

One of the questions in the “environmental conditions right now” section of the survey was on air movement preference. Subjects were asked whether they preferred less, no change in, or more air movement. These data were plotted against operative temperature to see if control group subjects had a higher preference for more air movement than TAC group subjects at higher operative temperatures. It was anticipated that the TAC group could satisfy their personal preferences by adjusting the local air movement with their desktop TAC units. Figures 10a (SI units) and 10b (I-P units) show the percentage of subjects preferring more air movement at a given operative temperature. The same observations used in the thermal sensation analysis above were used here with the exception that a few observations had to be dropped since not all subjects responded to the question. Forty-eight observations were included for the TAC group and 47 observations

**TABLE 6a**  
**Frequency Distribution of Air Movement Preference: TAC Group**

T <sub>OP</sub> (°C)	T <sub>OP</sub> (°F)	Sample Size	Average Air Movement Preference	Percent Preferring More Air Movement	Air Movement Preference Votes		
					1 (Less)	2 (No Change)	3 (More)
21.5	70.7	3	1	0%	2	1	-
22.0	71.6	9	1.67	0%	3	6	-
22.5	72.5	11	2.18	27%	1	7	3
23.0	73.4	12	2.17	17%	-	10	2
23.5	74.3	11	2.27	27%	-	8	3
24.0	75.2	-	-	-	-	-	-
24.5	76.1	2	2.50	50%	-	1	1
25.0	77.0	-	-	-	-	-	-

**TABLE 6b**  
**Frequency Distribution of Air Movement Preference: Control Group**

T <sub>OP</sub> (°C)	T <sub>OP</sub> (°F)	Sample Size	Average Air Movement Preference	Percent Preferring More Air Movement	Air Movement Preference Votes		
					1 (Less)	2 (No Change)	3 (More)
21.5	70.7	-	-	-	-	-	-
22.0	71.6	2	1.50	0%	1	1	-
22.5	72.5	23	2.22	43%	5	8	10
23.0	73.4	16	2.56	63%	1	5	10
23.5	74.3	2	3.00	100%	-	-	2
24.0	75.2	3	2.67	67%	-	1	2
24.5	76.1	1	3.00	100%	-	-	1
25.0	77.0	-	-	-	-	-	-

were included for the control group. The data are shown in Tables 6a and 6b. The measured air speed for each observation was based on an average of the two upper (1.1 m and 0.6 m) anemometers of the physical measurement cart because these were representative of the region in which the desktop supply nozzles could directly affect air movement.

Figure 10 shows that the control group has a significantly higher preference for more air movement at higher temperatures. For operative temperatures above 73°F (23°C), more than 67% of all control subjects wanted more air movement. This compares to less than 50% of the TAC subjects over this same temperature range. In a finding similar to those discussed above for thermal sensation, the slope (obtained by a weighted linear regression) for the control group (slope = 0.309, p-value = 0.017) was more than double that of the TAC group (slope = 0.148, p-value = 0.025). Despite the large

difference in slopes there is still a 19% probability (p-value = 0.19) that the difference occurs by chance.

Though the slopes for each group may not be statistically different for this limited database, the actual percentages of subjects preferring more air movement are noticeably offset from one another. A comparison of the linear models indicates that the percent preferring higher air movement is significantly higher (single tail p-value < 0.03) in the control group than in the TAC group at operative temperatures between 72°F (22.3°C) and 74.8°F (23.8°C). For operative temperatures above 74.8°F (23.8°C), the largest p-value was still less than 0.08.

Reviewing the air speeds recorded with the measurement cart during each workstation visit, we found that 15 of the 81 single-point measurements were greater than 40 fpm (0.20 m/s) for the TAC group, compared with only 3 of 80 measurements exceeding this level for the control group. These results

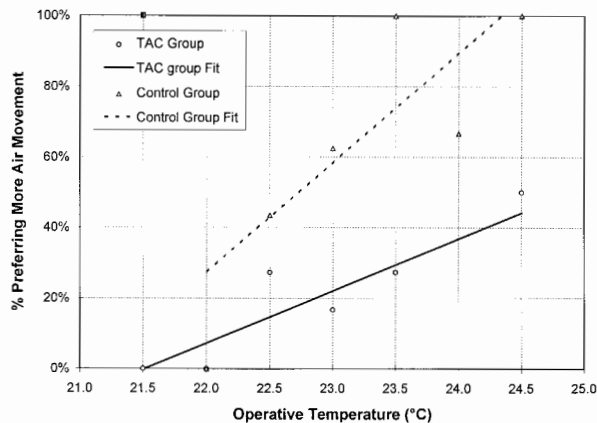

**Figure 10a** Mean binned air movement preference: TAC group vs. control group, all buildings, July 1996 (SI).

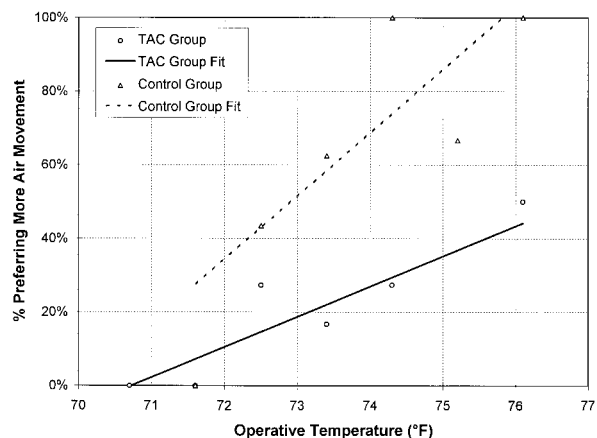

**Figure 10b** Mean binned air movement preference: TAC group vs. control group, all buildings, July 1996 (I-P).

support the conclusion that given individual control, some building occupants will choose to increase their local air speed above maximum levels that are prescribed for centrally controlled building environments (ASHRAE 1992).

The flatter slopes for both air movement preference and thermal sensation vs. temperature indicate that people may be able to widen their zone of acceptable comfort when they have air movement that is under their control. This same result was obtained in a recent laboratory study of occupant cooling at warm temperatures by personally controlled air movement (Arens et al. 1997). In addition, the air movement preference results for the control group support those from ASHRAE research project 702, where a majority of subjects in mechanically conditioned offices (no individual control of local airflow) preferred more air movement for operative temperatures above 74.3°F (23.5°C) (de Dear and Fountain 1994b).

## Occupant Use of TAC Units

Figure 11 presents aggregated data showing how on average the occupants in each building used the controls of the desktop TAC unit during the three July test periods. The data were collected through the desktop TAC system monitoring network during the period July 8 through August 4, 1996, and, as shown, represent the average position of each of the six desktop TAC unit controls or monitored points. With the exception of mixed air temperature, which represents the average supply air temperature, all bar graphs in Figure 11 represent occupant-adjustable controls. The vertical axes for fan speed, radiant heater, task light, and white noise display the average position of the desktop control slider that could be adjusted anywhere from its minimum setting (0%) to its maximum setting (100%). The vertical axis for temperature adjustment shows the control slider position from maximum cooling (–10) to maximum recirculation (0). Within each bar graph, there are four sets of bars, one for each of three buildings and a fourth for overall average. Each set consists of three bars—one for the normal period, one for the set-up period, and one for the set-down period. All data available up to July 19, 1996, were included in the normal period—approximately 12 working days. For the set-down and set-up periods, the day of the site visit plus the preceding day were included in this figure. An average was found for each workstation during occupied hours, and the overall average of these individual averages was found for each site. A total of 28 desktop TAC units were used for this analysis, 9 from Building A, 12 from Building B, and 7 from Building C. Not shown is the orientation of the desktop supply vents; it is conceivable that occupants would adjust these to provide either increased or decreased cooling. The key results from this analysis are as follows:

- Considering that the set-up period in Building A was actually a set-down and the set-down was a larger set-down, the trends in the three thermal controls indicate that occupants were adjusting their TAC units to adapt to the different environments. As space temperature decreased, fan speed decreased, the temperature slider was moved up to provide warmer recirculated air rather than cool primary air, and radiant heater use also increased. All three of these responses combined indicate that occupants were trying to create a warmer environment in response to cooler ambient conditions.
- In Building B, moderate set-up and set-down temperatures were achieved. There are indications that occupants used all three thermal controls to personalize their environments, but the differences between the three test periods are rather small and do not follow a consistent pattern. A more obvious response in Building B may have been observed if the set-up and set-down conditions had differed more from normal temperatures.
- The occupants in Building C showed a clear response to the set-up period by utilizing the fans. The average control setting doubled from 20% to 40%. Since the desktop



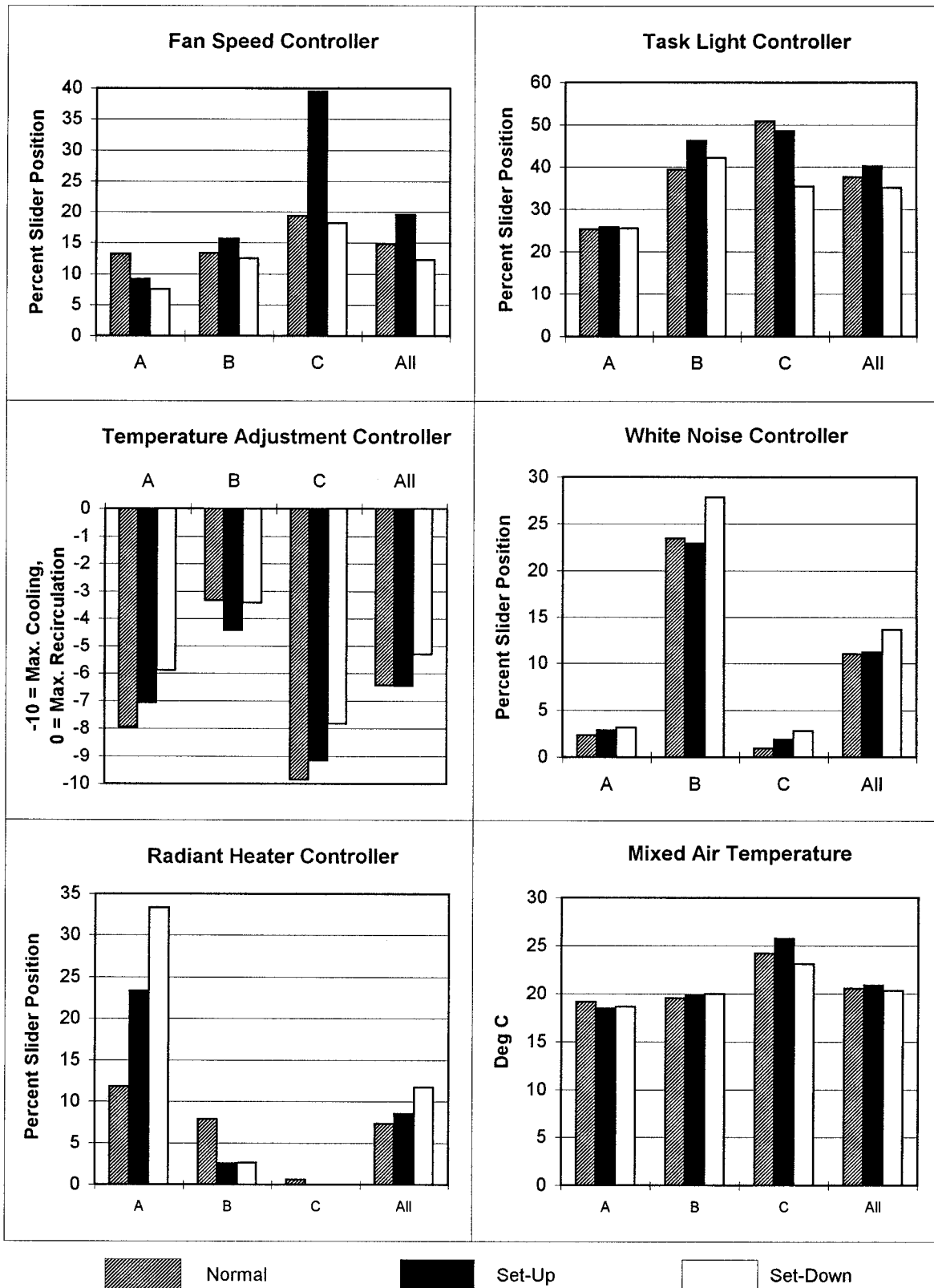

Figure 11 Aggregated TAC use data.

TAC units in Building C used only recirculated room air (no ducted cool primary air), the occupants may have needed increased air motion to provide the necessary cooling.

- The task light controls were used extensively in all three buildings. The fact that an ambient lighting system that was designed to meet task needs is present in all sites and task lights are still desired suggests one of two things: the lumen maintenance of the ambient system is poor or the ambient system as designed is insufficient for task needs.
- The white noise generators were really only used in Building B. The workstations utilizing this control were located mostly in one area where occupants used telephones extensively.
- Overall, all five controls were utilized by the occupants with desktop TAC units.

### Individual Patterns of Use

Though aggregated data as shown in Figure 11 are useful, they do not tell the complete story—the individuality of occupants and their patterns of use are lost. Given that the task lights were used extensively in all three sites and that the white noise generator is a control of secondary interest, the focus in analyzing the patterns of use of individuals was on the thermal controls. Table 7 summarizes the use of the desktop TAC units

**TABLE 7**  
**Number of Occupants Using Desktop Thermal Controls (Responses/TAC Units)**

	Building A	Building B	Building C	Overall
Cooling Response	0/0	5/14	6/7	11/21
Heating Response	6/11	5/14	3/7	14/32
Thermal Response	10/11	12/14	6/7	28/32

in the context of the set-up and set-down periods. The table indicates the number of occupants who showed a response to the set-up or set-down periods or who used the thermal controls significantly over the three-week period of study (July 15 - August 1, 1996). A response to the set-up period was defined as some response by the occupant to reduce the amount of heat produced by the desktop unit or to increase the amount of cooling provided by the unit. The converse was true for the set-down period. An occupant was defined as showing some thermal response if he or she used any of their thermal controls over the three-week period to some degree. “Some degree” in this context would mean for a few hours on several occasions. If an occupant used one of the thermal controls for one hour in the study period, that use would not be considered a thermal response.

The table shows there was some type of response to the set-up and set-down periods by approximately half of the occupants. Overall, 88% of the occupants used the desktop TAC thermal controls to some extent over the three-week period.

Observing the individual patterns of use suggests that the occupants generally do not adjust their desktop controls unless the ambient conditions change. The few occupants who do adjust their desktop TAC units during the day do so only a couple of times, and, for the most part, they adjust the control as if it were a switch or a 2-3 position controller. No occupant fine-tuned the unit as if it were a continuous analog control. A wide range of patterns of individual occupant use was obtained during the July monitoring period. The results for all TAC units in the study can be found in Bauman et al. (1997).

### CONCLUSIONS

This report describes the results of a field study to assess the impact of installing desktop task/ambient conditioning (TAC) units at 42 selected workstations within three office buildings of a large financial institution in San Francisco. The desktop TAC system is an example of a relatively new approach to space conditioning and control in which individuals are given the ability to control critical environmental conditions within their local work areas (e.g., workstations). Each office worker can adjust airflow, temperature, lighting, and acoustic characteristics to maintain personal comfort levels. By improving employee satisfaction and well-being, it is anticipated that the installation of a TAC system could lead to increased worker productivity and effectiveness.

Installation of the desktop TAC units increased overall occupant satisfaction in all six building assessment categories studied. The largest increases occurred for thermal quality, acoustical quality, and air quality. In terms of specific environmental factors, increased occupant satisfaction levels among the TAC group were strongly significant in comparison to changes within the control group for temperature and temperature control and were somewhat significant for air movement, lighting level, visual quality of computer screen, background noise, freedom from distracting noises, and conversational privacy. Almost all of these factors are addressed by the personal control capabilities of the desktop TAC system.

The results indicated that workers in the control group were twice as sensitive as those in the TAC group in terms of their thermal sensation and preference for higher air movement in response to changes in ambient temperature. The change in preference for higher air motion within the TAC group was quite dramatic, as it decreased from 54% in the baseline survey to only 15% in the post-installation survey, and 77% (up from 36%) indicated that no change was required. By comparison, almost 60% of the control group subjects indicated a preference for higher air movement in both surveys. These findings indicate that people may be toler-

ant of a wider range of temperatures when they have air movement that is under their control.

Survey results indicated that more than 80% of the desktop TAC unit users adjusted the controls less frequently than once each day. This suggests that it is more important for workers to have the ability to control their local environment than it is for them to actually make a large number of control adjustments. Monitored occupant use patterns found that about half of the TAC group adjusted the thermal controls in a way that was consistent with the change in temperature during the set-up and set-down periods. Overall, 88% of the TAC group used the desktop thermal controls to some extent (although rather infrequently) over the July test period.

## ACKNOWLEDGMENTS

This field study was funded by Johnson Controls World Services; special thanks to Walter Mallory of Integrated Facility Management (IFM) in the San Francisco office and to Carol Lomonaco from Johnson Controls in Milwaukee for their support and assistance. This field study would not have been possible without the cooperation and participation of the Bank of America employees at the three test buildings. We are especially thankful to Willy Demel for facilitating the field study and to Karla Schikore for her enthusiastic support; both are with Bank of America Corporate Real Estate. Luisa Caldas, a graduate student researcher, provided valuable assistance during the data analysis and report writing phase of this project, and Tim Xu, a Ph.D. candidate, assisted us during the data collection phase; both are with the Center for Environmental Design Research (CEDR) at U.C. Berkeley. The project was expertly administered by Nora Watanabe and her friendly staff, Kimberley Allen and Annette Quinn, of CEDR at U.C. Berkeley.

## REFERENCES

- Akimoto, T., F.S. Bauman, C.C. Benton, and E.A. Arens. 1996. Field study of a desktop-based task conditioning system. *Transactions of AIJ (Architectural Institute of Japan)*, No. 490, Dec., pp. 35-46.
- Arens, E.A., F. Bauman, L. Johnston, and H. Zhang. 1991. Testing of localized ventilation systems in a new controlled environment chamber. *Indoor Air*, No. 3, pp. 263-281.
- Arens, E., T. Xu, K. Miura, H. Zhang, M. Fountain, and F. Bauman. 1997. A study of occupant cooling by personally controlled air movement. *Energy and Buildings*, 26 (3).
- ASHRAE. 1992. *ANSI/ASHRAE Standard 55-1992, Thermal environmental conditions for human occupancy*. Atlanta: American Society of Heating, Refrigerating and Air-Conditioning Engineers, Inc.
- ASHRAE. 1989. *ANSI/ASHRAE Standard 62-1989, Ventilation for acceptable indoor air quality*. Atlanta: American Society of Heating, Refrigerating and Air-Conditioning Engineers, Inc.
- Baughman, A., E. Arens, F. Bauman, and C. Huizenga. 1995. Indoor environmental quality (IEQ) assessment system—Phase 1 Project Report: Development of IEQ method and field demonstration at U.C. Davis Medical Center. Submitted to Johnson Controls, Inc., Center for Environmental Design Research, University of California, Berkeley, Dec. 15.
- Bauman, F.S., H. Zhang, E. Arens, and C. Benton. 1993. Localized comfort control with a desktop task conditioning system: laboratory and field measurements. *ASHRAE Transactions* 99 (2).
- Bauman, F.S., and M. McClintock. 1993. A study of occupant comfort and workstation performance in PG&E's advanced office systems testbed. Center for Environmental Design Research, University of California, Berkeley, May, 135 pp.
- Bauman, F., E. Arens, M. Fountain, C. Huizenga, K. Miura, T. Xu, T. Akimoto, H. Zhang, D. Faulkner, W. Fisk, and T. Borgers. 1994. Localized thermal distribution for office buildings; Final report—Phase III. Center for Environmental Design Research, University of California, Berkeley, July, 115 pp.
- Bauman, F., and E. Arens. 1996. Task/ambient conditioning systems: Engineering and application guidelines. Center for Environmental Design Research, University of California, Berkeley, Oct., 67 pp.
- Bauman, F., A. Baughman, G. Carter, and E. Arens. 1997. A field study of PEM (personal environmental module) performance in Bank of America's San Francisco office buildings. Center for Environmental Design Research, University of California, Berkeley, April, 150 pp.
- Benton, C., F. Bauman, and M. Fountain. 1990. A field measurement system for the study of thermal comfort. *ASHRAE Transactions* 96 (1).
- de Dear, R., and M. Fountain. 1994a. Field experiments on occupant comfort and office building thermal environments in a hot-humid climate. *ASHRAE Transactions* 100 (2).
- de Dear, R.J., and M.E. Fountain. 1994b. Thermal comfort in air conditioned office buildings in the tropics. *AIRAH Journal* 48, No. 9 (Sept.).
- de Dear, R., and Brager, G.S. 1998. Developing an adaptive model of thermal comfort and preference. *ASHRAE Transactions* 104 (1).
- Faulkner, D., W.J. Fisk, and D.P. Sullivan. 1993. Indoor air flow and pollutant removal in a room with desktop ventilation. *ASHRAE Transactions* 99 (2).
- ISO. 1985. *International Standard 7726, Thermal environments—Instruments and methods for measuring physical quantities*. Geneva: International Standards Organization.
- Kroner, W., J. Stark-Martin, and T. Willemain. 1992. Using advanced office technology to increase productivity: The impact of environmentally responsive workstations

(ERWs) on productivity and worker attitude. The Center for Architectural Research, Rensselaer, Troy, N.Y.  
Post, N.M. 1993. Smart buildings make good sense. *Engineering News Record*, May 17.

Schiller, G., E. Arens, F. Bauman, C. Benton, M. Fountain, and T. Doherty. 1988. A field study of thermal environments and comfort in office buildings. *ASHRAE Transactions* 94 (2).