

1999

Film Dialogue Translation And The Intonation Unit : Towards Equivalent Effect In English And Chinese

Jian Li
Edith Cowan University

Follow this and additional works at: <https://ro.ecu.edu.au/theses>



Part of the [Education Commons](#)

Recommended Citation

Li, J. (1999). *Film Dialogue Translation And The Intonation Unit : Towards Equivalent Effect In English And Chinese*. <https://ro.ecu.edu.au/theses/1480>

This Thesis is posted at Research Online.
<https://ro.ecu.edu.au/theses/1480>

Edith Cowan University

Copyright Warning

You may print or download ONE copy of this document for the purpose of your own research or study.

The University does not authorize you to copy, communicate or otherwise make available electronically to any other person any copyright material contained on this site.

You are reminded of the following:

- Copyright owners are entitled to take legal action against persons who infringe their copyright.
- A reproduction of material that is protected by copyright may be a copyright infringement. Where the reproduction of such material is done without attribution of authorship, with false attribution of authorship or the authorship is treated in a derogatory manner, this may be a breach of the author's moral rights contained in Part IX of the Copyright Act 1968 (Cth).
- Courts have the power to impose a wide range of civil and criminal sanctions for infringement of copyright, infringement of moral rights and other offences under the Copyright Act 1968 (Cth). Higher penalties may apply, and higher damages may be awarded, for offences and infringements involving the conversion of material into digital or electronic form.

**Film Dialogue Translation and the Intonation Unit:
Towards Equivalent Effect in English and Chinese**

Jian Li

BA, MA (Applied Linguistics)

A Thesis Submitted in Fulfilment of the Requirements for the Award of
PhD in Applied Linguistics

Edith Cowan University, Perth

March 1999

USE OF THESIS

The Use of Thesis statement is not included in this version of the thesis.

ABSTRACT

This thesis proposes a new approach to film dialogue translation (FDT) with special reference to the translation process and product quality of English-to-Chinese dubbing. In response to the persistent translation failures that led to widespread criticism of dubbed films and TV plays in China for their artificial ‘translation talk’, this study provides a pragmatic methodology derived from the integration of the theories and analytical systems of information flow in the tradition of the functionalist approach to speech and writing with the relevant theoretical and empirical findings from TS and other related branches of linguistics. It has developed and validated a translation model (FITNIATS) which makes the intonation unit (IU) the central unit of film dialogue translation.

Arguing that any translation which treats dubbing as a simple script-to-script process, without transferring the prosodic properties of the spoken words into the commensurate functions of TL, is incomplete, the thesis demonstrates that, in order to reduce confusion and loss of meaning/rhythm, the SL dialogue should be rendered in the IUs with the stressed syllables well-timed in TL to keep the corresponding information foci in sync with the visual message. It shows that adhering to the sentence-to-sentence formula as the translation metastrategy with the information structure of the original film dialogue permuted can result in serious stylistic as well as communicative problems.

Five key theoretical issues in TS are addressed in the context of FDT, viz., the relations between micro-structure and macro-structure translation perspectives, foreignizing vs. domesticating translation, the unit of translation, the levels of translation equivalence and the criteria for evaluating translation quality. If equivalent effect is to be achieved in all relevant dimensions, it is argued that 'FITness criteria' need to be met in film translation assessment, and four such criteria are proposed.

This study demonstrates that prosody and word order, as sensitive indices of the information flow which occurs in film dialogue through the creation and perception of meaning, can provide a basis for minimizing cross-linguistic discrepancies and compensating for loss of the FIT functions, especially where conflicts arise between the syntactic and/or medium constraints and the adequate transfer of cultural-specific content and style. The implications of the model for subtitling are also made explicit.

TO MY MOTHER (1918 -1991)
WHO TAUGHT ME TO PERSEVERE

DECLARATION

I certify that this thesis does not incorporate without acknowledgement any material previously submitted for a degree or diploma in any institution of higher education; and that to the best of my knowledge and belief it does not contain any material previously published or written by another person except where due reference is made in the text.

Jian Li
Feb. 1999

ACKNOWLEDGEMENTS

I am grateful for the help and support of many people in enabling this thesis to become a reality and I regret that space does not permit them all to be mentioned here.

First and foremost, beyond power of words goes my deepest gratitude to my supervisor, Professor Ian G. Malcolm, for the best kind of guidance, assistance and encouragement that a research student can ever expect to get. Without his sagacious and unreserved help, this PhD study would not have been possible, nor would the thesis have been upgraded to the present form. Not only did he respond to every mention of my needs and requests in the most prompt and scholarly manner, but also he offered me facilities and avenues to the best of his ability to keep my research up and running and my information and knowledge of the field updated. I am grateful for his effort to widen my horizons by urging and supporting me to attend the two international conferences on translation studies at the crucial junctures of my research when I was most in need of insights, inspiration and confidence. I hasten to support the view shared by many of his students that to work under him is always a privilege, pleasure and precious learning opportunity, not only for his masterful linguistic knowledge and language power but also for being with the best example of a man of high professional and personal standards.

I also owe special thanks to Associate Professor Brian Shoemith and Dr. Tian Se Ang for their invaluable expert opinions provided in relation to Asian film and Chinese language respectively in the preparation of the thesis drafts.

I am very grateful to many other people at Edith Cowan University and beyond who helped me in one way or another in the course of this study. To Associate Professor Robyn Quin, Head of Communications and Multimedia, I am indebted for her generous subsidy to cover the airfare (together with Prof. Ian Malcolm) for my trip to the 1996 Berlin conference on Translating for the Media. This support led to my having the opportunity to meet and open up a timely interaction with such leading

translation scholars as Professor Irena Kovacic and Professor Yves Gambier. Many thanks are due to Dr. David Elder and Dr. Wally Frick of Edith Cowan University for their concern and input in the early stages of this work, especially their very helpful comments and suggestions derived from their expertise in translation between English and French/German.

The staff of the Library of Edith Cowan University have left me with a beautiful impression of being the most friendly and obliging people, many of whom worked diligently behind the scene in providing quality help and services to people with many requests like me. Among so many others, Jenny Marshall and Julia Gross deserve my special thanks for their warm support and instant assistance to my initial research needs.

This programme was generously sponsored by the Australian Agency for International Development (AusAID), whose financial support I greatly appreciate. I will always hold dear the privilege of being a beneficiary of an AusAID Scholarship whereby my treasured Australian experience was made possible.

Many people offered assistance during my fieldwork in China in 1994. Among them my sincere thanks go to the staff of the Guangdong Television (GDTV), especially to Mr. ZHANG Shiliang, Head of Centre for the Production of the Television Art, from whom I obtained the videotapes for the dubbed and subtitled versions of *Jackie* with the original translation script and subtitles; Ms WANG Di, Dubbing Director of the GDTV, who directed the dubbing of the mini-series and offered much first-hand data on film/TV dubbing in China; and Ms XU Ning, Translator of the TV Station's dubbing team, without whose helpful introductions I would not have had an inside view and actual experience of the relevant topic for my investigation. The data preparation in this study has also benefited immensely from the generosity and kindness of many other people. Among them, I owe my gratitude especially to Mr. Walter Hoylman, Sound-mixer of the teleplay *Jackie*, for providing me with the complete original shooting-script from his personal archive. To John Duff, Media

Technician at Edith Cowan University, I am thankful for his devoted assistance which was important to my analysis of the audio-visual materials for this thesis. My thanks also go to my wife and daughter for patiently helping me with the transcriptions from the film soundtrack in either Chinese or English.

No one has been so immediately and so continuously affected by my full-time commitment to this prolonged project as my wife and daughter. Its enormous emotional and economic impact on their life situation commanded all their patience, forbearance and willpower, for which I shall always be grateful. Thanks to my wife for her support and sacrifice for so many years. Her foresight, realism and persistence guaranteed the writing of this thesis to continue against all the odds through to the end.

I am extremely fortunate in having so many comforting and helpful friends close by whose spiritual as well as material support were essential to the completion of this work. While they are too numerous to list, I would make special mention of just a few among my Chinese friends to whom I owe the greatest debt. To Dr. XU Jiake and Jenny Leung, my gratitude is not only due to their specific help with the organizing and delivery of the Jackie script from the United States and the very comforting and much-needed offers they made to relieve the mental and budgetary pressure I was under, but also to their being most reliable and admirable friends whose integrity has always been a source of inspiration to me.

To CHEN Minzhong and CAI Xiaorong, my thanks will go on and on for their special assistance in providing me with accommodation and financial help and looking after much of the day-to-day affairs on behalf of me while I was away from my family. It was under their care that the first draft of this thesis was being done. I also express my heartfelt appreciation to 'friends in need' ZHUANG Zhonghui and ZHANG Yue, who offered an ideal living and working environment to me where I was able to carry on uninterruptedly with the virtual rewriting of most of the thesis draft through to its final version. Their generosity, compassion and unelicited

readiness to help will always be remembered as an indispensable contribution to this PhD work.

To Mr. ZHANG Wenhao, my long-time friend, who never failed to make me feel at home during my stay in Hong Kong on my trips in relation to this research project, I express my deep thanks for his concern for my thesis as well as his warm and bountiful reception.

Finally, a deep salute to my Dad, for his love, upbringing and encouragement. From his support and expectations of the accomplishment of my studies overseas, as well as those of the whole family's, I have drawn so much comfort and strength over the years. To my sisters especially, I owe their wholehearted care and help since my formative years without which I could not have attained the level of education I desired.

JL

Inglecrest Apt., Perth

Summer 1999

LIST OF ABBREVIATIONS

AAP	autonomous adjacency pair
AP	adjacency pair
ASP	aspect marker in Chinese
A-T-S	analysis-transfer-synthesis
CAP	consecutive adjacency pair
CD	communicative dynamism
CND	China News Digest
DLL	<i>Dictionary of Language and Linguistics</i> , ©1972 by R.R.R. Hartmann & F.C. Stork, London: Applied Science Publishing Ltd.
E	exclamatory marker in Chinese
F	focus marker in Chinese
FD	film dialogue
FDs	film dialogue in the source language ('film dialogue source')
FDt	film dialogue in the target language ('film dialogue target')
FDT	film dialogue translation
FIT	factual content, illusion and textuality
FITNIATS	The FIT-bound, NI-sync, A-T-S translation model for dubbing
FSP	functional sentence perspective
IF	information flow
IFG	<i>An Introduction to Functional Grammar</i> by M.A.K. Halliday 1994
IU	intonation unit
LDA	<i>Longman Dictionary of Applied Linguistic</i> . ©1985 by J. Richards et al. Longman.
LOC	locational suffix in Chinese
M	mood marker in Chinese
MOD	modifier marker in Chinese
MSR	measure word in Chinese

MT	machine translation
NEG	negative emphasis marker in Chinese
NI	new information
NLP	natural language processing
PAS	passive voice marker in Chinese
PP	prosodic prominence
PreP	prepositional marker in Chinese
Q	question marker in Chinese
SA	speech act
SAS	speech act sequence
SL	source language
SLT	spoken language translation
T	topic marker in Chinese
TAP	terminated adjacency pair
TE	translation equivalence
TL	target language
TLT	target language text
TQ	translation quality
TS	translation studies
UAP	unsettled adjacency pair
UT	unit of translation

TABLE OF CONTENTS

Abstract	iii
Dedication	v
Declaration	vi
Acknowledgements	vii
List of abbreviations	xi
List of Tables	xviii
List of Figures	xx

CHAPTER

1. INTRODUCTION	1
1.1 Background	1
1.1.1 Defining 'Film Dialogue Translation'	2
1.1.2 The Global View	3
1.1.3 Film Dialogue Translation in China	7
1.2 Problems	10
1.2.1 In General	11
1.2.2 Problems in Film Dialogue Translations in China	12
1.2.2.1 Dubbing	13
1.2.2.2 Subtitling	15
1.3 Purpose and Organisation of the Study	17
1.3.1 Aims of the Thesis	17
1.3.2 Plan of the Thesis	22
Notes	27
2. THEORETICAL ORIENTATION: FILM DIALOGUE AND FILM DIALOGUE TRANSLATION	33
Part One: Film Dialogue as a Discourse Type	33
2.1 Preliminary Review	33
2.1.1 The Long Overdue Task	34
2.1.2 Search for Relevance	38

2.1.2.1 Earlier Investigations Into Stylistic Features of Conversational Discourse	40
2.1.2.2 Later Research on Dramatic Discourse Analysis	50
2.1.3 Sociolinguistic Interpretations	63
2.1.3.1 Form and Function	63
2.1.3.2 Chafe's Four-Quadrant Division	68
2.1.3.3 Planned vs Unplanned Discourse	72
2.1.4 Summary	75
Part Two: Survey of the Field of Translation Studies	78
2.2 General Review	78
2.2.1 Sociolinguistic Approach	79
2.2.2 The Ethnography of Communication and its Implications for Translation	84
2.2.3 Text Typologies and Translation	88
2.2.4 Pragmatics-informed Approach	91
2.2.4.1 The Textual Approach	93
2.2.4.2 The Variational Approach	97
2.2.4.3 Summary	102
2.3 Drama translation	104
2.3.1 Introduction	105
2.3.2 Zuber's Contribution to Drama Translation	107
2.3.3 Text and Performance	111
2.3.4 Drama Translation Principles and Strategies	115
2.3.5 Translating Rhythm in Drama Dialogue	120
2.3.6 Drama Translation and Film Dialogue Translation	125
Part Three: Film Dialogue Translation	134
2.4 Research in Film Dialogue Translation	134
2.4.1 Film Dialogue Translation in TS	135
2.4.2 Dubbing vs Subtitling	139
2.4.3 Dubbing	141
2.4.3.1 A Plot-oriented Translation Approach to Dubbing	142
2.4.3.2 Dubbing TV Comedies	143
2.4.3.3 Prosodic Functions and Information Perception in Dubbing	146
2.4.3.4 The Question of Credibility and Synchronism in Dubbing	147
2.4.4 Subtitling	152
2.4.4.1 Subtitling: Characteristics, Effects of the Constraints and Problem-solving Strategies	153
2.4.4.2 Applications of Linguistic Theories to Subtitling	159
2.4.4.3 Other Major Studies on Subtitling	161

2.4.5 Summary	165
2.5 Trends and Tendencies in China	167
2.5.1 The State of the Art	168
2.5.1.1 The Practice	168
2.5.1.2 The Theory	177
2.5.2 Summary	193
2.6 Need for Theoretical Input in FDT	194
Notes	198
3. THE INFORMATION FLOW PERSPECTIVE	208
3.1 Introduction	208
3.2 Information Flow	214
3.2.1 Overview	215
3.2.2 Functional Sentence Perspective	218
3.2.2.1 Communicative Dynamism	218
3.2.2.2 Interacting Factors in FSP	221
3.2.2.3 FSP in Translation Studies	223
3.2.2.4 FSP in Spoken Communication and its Relevance to Film Translation	226
3.2.3 Halliday's Approach to Information Flow	229
3.2.3.1 The Clause	230
3.2.3.2 Metafunctions	236
3.2.3.3 Thematic Structure	241
3.2.3.4 Information Structure	244
3.2.3.5 Implication for Film Dialogue Translation	255
3.2.4 Chafe's Functional-Cognitive Model	271
3.2.4.1 Threefold Distinction of New-Accessible-Given Information	272
3.2.4.2 Intonation Unit	273
3.2.4.3 Chafe's View on the Clause	275
3.2.4.4 Two Cognitive Constraints on Spoken Language	276
3.2.4.5 Sayability and Covert Prosody in Written Language	277
3.2.4.6 The Analytical Methodology and its Applicability to the Present Study	278
3.3 Summary	282
Notes	286

4. A MODEL FOR FILM DIALOGUE TRANSLATION	291
4.1 Towards an FDT Model Based on Information Flow Theories	291
4.1.1 Micro-structure vs Macro-structures	293
4.1.2 Literal Translation and SL-oriented Translation	297
4.1.3 Unit of Translation of Film Dialogue	370
4.1.4 FIT - the Principle of Equivalent Effect in FDT	312
4.1.4.1 Form and Functions of Film Dialogue in the Context of Dubbing	313
4.1.4.2 FITness - Standards for Evaluating FDT Quality	324
4.1.5 Summary	351
4. 2 Presentation of the Model	352
4.2.1 The FITNIATS Model	352
4.2.2 The Data	355
4.2.3 Description of the Method	357
4.2.3.1 Analysis of FDs	359
4.2.3.2 The Translation Process of FDT	364
4.2.3.3 Comparison, Evaluation and Discussion of the Findings	372
4.2.4 Validity of the Model	374
Notes	378
5. APPLICATION OF THE FITNIATS MODEL	381
5.1 The Test Case: Jackie	381
5.2 Sample 1: <i>Breakup</i>	384
5.2.1 Analysis of the Source Text	385
5.2.2 Comparison and Evaluation	401
5.2.3 Discussion of the Results	440
5.3 Sample 2: <i>Estrangement</i>	449
5.3.1 Analysis of the Source Text	450
5.3.2 Comparison and Evaluation	459
5.3.3 Discussion of the Results	478
5.4 Sample 3: <i>Mutuality</i>	482
5.4.1 Analysis of the Source Text	482
5.4.2 Comparison and Evaluation	485
5.4.3 Discussion of the Results	489

5.5 General Discussion of the Results	492
Notes	503
6. IMPLICATIONS FOR SUBTITLING	506
6.1 Speech and Writing	506
6.1.1 Subtitling is Mixed Language	507
6.1.2 Subtitling is a Special Type of SLT	509
6.2 Dubbing and Subtitling	512
6.2.1 Subtitles out of the Dubbing Script	513
6.2.2 Applicability of the FITNIATS Model to Subtitling	516
6.3 Summary	529
Notes	537
7. CONCLUSION	539
7.1 Concluding Remarks	539
7.2 Limitations	546
7.3 Recommendations for Further Research	549
7.4 Looking into the Future: The “Titanic Phenomenon”	555
Notes	562
REFERENCES	565

LIST OF TABLES

Table 1	Forms of Genre Crossover in the Process of Translation (Interpreting Hervey & Higgins 1992:158)	127
Table 2	Film Dialogue Translation as Different Subject Matter Derived from Its Interdisciplinary Complexities	196
Table 3	Infrastructure and Correlates of the Metafunctions (According to Halliday 1994)	238
Table 4	Speech function and responses (From IFG:69)	254
Table 5	Meaning of FIT	317
Table 6	Dubbing-oriented translation procedures under the FITNIATS model	371
Table 7	Sample 1: Number and percentage of types of adjacency pairs ascribed to each character	389
Table 8	Structural breakdown of the Scene <i>Break-up</i> and the contextual relations between its components from both informational and interactional perspectives	400
Table 9	Sample 1 - SAS#1: Number of syllables in each turn and the difference between FDs and FDt	411
Table 10	Sample 1 - SAS#1: Instances of loss of NI synchronicity with the original timing obtained in FDt1	412
Table 11	Sample 1 - SAS#2: Number of syllables in each turn and the difference between FDs and FDt	419
Table 12	Sample 1 - SAS#2: Instances of loss of NI synchronicity with the original timing obtained in FDt1	420

Table 13	Sample 1 - SAS#3: Number of syllables in each turn and the difference between FDs and FDt	432
Table 14	Sample 1 - SAS#3: Instances of loss of NI synchronicity with the original timing obtained in FDt1	432
Table 15	Sample 1 - SAS#4: Number of syllables in each turn and the difference between FDs and FDt	439
Table 16	Sample 1 - SAS#4: Instances of loss of NI synchronicity with the original timing obtained in FDt1	439
Table 17	Sample 1: Differences in syllables used between FDs and FDt and NI failure in FDt1	442
Table 18	Sample 1: Causes of NI dislocation and their relative frequency in FDt1	444
Table 19	Sample 1: Types of mistranslation in FDt1	448
Table 20	Sample 2: Number and percentage of types of adjacency pairs ascribed to each character	453
Table 21	Structural breakdown of the Scene <i>Estrangement</i> and the contextual relations between its components from both informational and interactional perspectives	459
Table 22	Sample 2 - SAS#1: Number of syllables in each turn and the difference between FDs and FDt	463
Table 23	Sample 2 - SAS#1: Instances of loss of NI synchronicity with the original timing obtained in FDt1	463
Table 24	Sample 2 - SAS#2: Number of syllables in each turn and the difference between FDs and FDt	466
Table 25	Sample 2 - SAS#2: Instances of loss of NI synchronicity with the original timing obtained in FDt1	467

Table 26	Sample 2 - SAS#3: Number of syllables in each turn and the difference between FDs and FDt	471
Table 27	Sample 2 - SAS#3: Instances of loss of NI synchronicity with the original timing obtained in FDt1	471
Table 28	Sample 2 - SAS#4: Number of syllables in each turn and the difference between FDs and FDt	477
Table 29	Sample 2 - SAS#4: Instances of loss of NI synchronicity with the original timing obtained in FDt1	477
Table 30	Sample 2: Differences in syllables used between FDs and FDt and NI failure in FDt1	479
Table 31	Sample 2: Causes of NI dislocation and their relative frequency in FDt1	480
Table 32	Sample 2: Types of mistranslation in FDt1	481
Table 33	Structural breakdown of the Scene <i>Mutuality</i> and the contextual relations between its components from both informational and interactional perspectives	484
Table 34	Sample 3: Differences in syllables used between FDs and FDt and NI failure in FDt1	490
Table 35	Sample 3: Causes of NI dislocation and their relative frequency in FDt1	491
Table 36	Sample 3: Types of mistranslation in FDt1	492
Table 37	Spatial and temporal status of the subtitled versions in terms of subtitle length and duration	526

LIST OF FIGURES

Figure 1	An adapted schema of the dual-level relation in film discourse from Short (1989)	65
----------	--	----

Figure 2	Schematic Representation of Features of Spoken and Written Language	70
Figure 3	From Page to Stage: A Flow Diagram of Drama Translation Process in Relation to the SL Text and Performance	131
Figure 4	From Page to Stage: A Flow Diagram of Translation Process for Dubbing in Relation to the SL Text and Performance	133
Figure 5	Steps taken for dubbing a foreign film into Chinese by the Shanghai Television Station	176
Figure 6	Dubbing as Third Creation Art	185
Figure 7	The Relationships in the Joint Effect of Dubbing from Script to Soundtrack	192
Figure 8	Approximate Correspondence of Layers of Structure Between the Clause Framework and the Linguistic Realizations	232
Figure 9	Functions of Intonation as a Subsystem of the Global Functions of Language	240
Figure 10	Interactional structure of information flow with the tone construing a speech function on information structure that is to stimulate the response of the other speaker in dialogue	252
Figure 11	Constraints on dubbing and types of loss	320
Figure 12	The role of the translator in the dubbing process	323
Figure 13	The Translation Quality Assessment Model developed by House (1981)	326
Figure 14	Interpreting the Translation Quality Assessment Model by Stolze (1996)	326
Figure 15	Aspects of FITness viewed in different perspectives	332
Figure 16	An FIT-bound, NI-sync A-T-S model for dubbing (FITNIATS)	354
Figure 17	The basic binary structure of speech act sequence	362

Figure 18	Process of the case studies testifying the dual functions of the FITNIATS model	375
Figure 19	Basic discourse structure of <i>Jackie</i>	383
Figure 20	Sample 1: The performance of speech acts in the organization of the turn, AP and SAS	393
Figure 21	Sample 1: Syllable count by speech act sequence and discrepancies in percentage between FDs and FDt	442
Figure 22	Sample 2: The performance of speech acts in the organization of the turn, AP and SAS	456
Figure 23	Sample 2: Syllable count by speech act sequence and discrepancies in percentage between FDs and FDt	480
Figure 24	Sample 3: Syllable count by speech act sequence and discrepancies in percentage between FDs and FDt	490
Figure 25	Syllable count by samples and discrepancies in percentage between FDs and FDt	493
Figure 26	Instances in percentage of corrupted information structure in each sample	494
Figure 27	Percentage ratios of mistranslations and the distribution of the error types in each of the three samples in comparison	495

Chapter 1

INTRODUCTION

1.1 Background

Translation Studies have laid heavy emphasis on distinguishing types of translation (Nida 1974, Reiss 1981, Rose 1981, Hatim 1984, Bassnett 1991). Within the scope of established theories of translation, the classification of text type "as the translator's focus" (Hatim & Mason 1990:138) serves as the point of entry for any distinctive category of language data to be recognized and treated as the subject of a particular type of translation. Because it fails to fit the conventional "ideal" definitions of translation, interlingual translation of dramatic dialogue in film and television, had been traditionally disregarded by linguists as well as translation theorists (van Dijk 1985b, Crampton 1989, Delabastita 1989, Luyken et al 1991). The issue still lingers with respect to whether the recoding of speech in foreign language films and TV fiction is a legitimate type of translation. According to the literature available, opinion differs; but there is consensus of opinion that this worldwide

phenomenon of cross-cultural communication must not be slighted and that it urgently needs to be put under systematic linguistic-translational scrutiny.

1.1.1 Defining 'Film Dialogue Translation'

In this thesis, *film dialogue translation* (FDT) is used as an alternative term for the special type of translation that covers mainly dubbing and subtitling and is proposed as an appropriate one in preference to, but not to the exclusion of, film translation or screen translation¹. This is for the reason that, in the multi-channel complex of codes generated by a film, it is only film dialogue² (FD) that can be altered or re-encoded, even though the language transfer is not independent of the overall context of the medium. Since FD is the sole object of dubbing and subtitling, its nature, structures and functions deserve linguistic perusal in the light of spoken language translation preliminaries to inform research in FDT. In essence, based on what I would call the principle of "double economy"³, FD bears the basic characteristics of natural spoken language but enjoys "a greater freedom from ongoing cognitive constraints" (Chafe 1987:50) in its production, which gives rise to a hybrid discourse genre: a written-to-be-spoken

variety that is meant to be 'overheard' as if from real-life conversations.

In dealing with the translation of such a multi-channel and multi-code type of communication, the translator has to face problems on a new dimension of complexity, for the verbal code, viz., speech, is only one element in the totality of cinematic text. On the other hand, it is only the verbal code that the translation rests on in the TL film - unlike theatre translation, the visual signs on the screen always remain unchanged, so the only expression through which translation is realized is the representation of the original human voice attached to the end production. Obviously, the human voice on the screen as the translator's 'major target of attack' should be fully understood by means of scientific analysis.

1.1.2 The Global View

Despite the vigorous integration and expansion of discourse analysis ever since its emergence as a new cross-discipline at the beginning of the 1970s (van Dijk 1985a:8), film dialogue has always tended to escape the attention of discourse analysts who have engaged in examining varieties of text and talk with substantial results. This is as much a

thought-provoking negligence as the de-facto exclusion of film dialogue translation as an independent subject from Translation Studies prior to the early 90s (van Dijk 1985b:1; cf. Delabastita opcit:193; Luyken et al opcit:165). There are, of course, strong reasons on the basis of which the reluctance to accept film dialogue either as a sociolinguistic genre for discourse analysis or a favoured text type for translation can be accounted for. And the reasons, which can be briefly phrased in two summary terms, viz., medium constraints and historical prejudice, reside in the peculiarities of the film language itself. The spoken words heard from the characters on the screen are so subordinate to the visual image that they are reduced to frequent "cutting" or omission wherever the picture speaks better for itself. This sporadicness or incompleteness within the boundaries of a speech event has to some extent intensified "a bias towards 'high' literature that devalues work in the cinema, research in oral literature and electronics." (Bassnett 1991:133). However, with the influence of the global audio-visual mass communication and its consequent impetus to the improvement of programme quality, this narrow-minded elitist attitude towards popular culture can not be sustained much longer.

On another front, drama, the exemplary cousin of film, has been duly, though not adequately, studied in tune with the advances in discourse analysis. Based on various approaches to dramatic discourse, copious literature which has proved it an analysable genre can be retrieved from such revealing applications in the field as Burton (1980), Elam (1980), Widdowson (1982), Short (1989), van Stapele (1990) and Mateo (1995).

Although regarded as "one of the most neglected areas" of Translation Studies (Bassnett opcit:120), drama translation prospers on its way to becoming a new branch of science. Significant efforts have been made to establish a theory of its own for comprehensive typological analysis. It is noteworthy, however, that the invigorating proliferation of sociolinguistic approaches in the province of translation has hardly been reflected in the pertinent publications (Rose 1981, Zuber 1980, 1984, 1988), and more regretfully, the necessity of integrating the sociolinguistic practices of dramatic discourse analysis with the drama translation theory building has been overlooked almost completely.

Even though the amalgamation of the achievements in discourse analysis and translation in the service of drama is a gigantic task yet to be accomplished, the attempt to build up a more scientifically-informed approach to film dialogue translation by drawing on principles and methods for inter-lingual/cultural discourse studies seems to be both a practical and a promising one. Since both types of translation take dramatic representation of spoken language with a written basis as their object, elevation in theory and practice in one of the areas of research is likely to benefit the other either by way of fertilizing or borrowing. On the other hand, it must be fully realised that the two forms of translation differ in more ways than a few due to the media differences which determine that each deserves a concentrated study and has to be developed in its own field.

The "complex problems of translating cinematic texts" (Bassnett 1991:133) have received much academic attention since the advent of extensive linguistically-informed research into screen translation, which has promised a good answer to the influential plea for more "theoretical and scholarly knowledge about" and "better understanding of the semantics and linguistics of

Language Transfer" (Luyken et al 1991:165). while an impressive quantity of literature focused on subtitling is spearheading this long overdue trend, research into its twin subject, dubbing, is yet to catch up. Dubbing, particularly in terms of its translation process and the creation of TL script, "deserves much more objective, empirical research" (Zabalbeascoa 1994:99).

1.1.3 Film Dialogue Translation in China'

China's film translation industry was founded in July 1948 when the first national film dubbing studio started to operate in the Northeast city Changchun. Eight years later China set up another specialized film dubbing studio in Shanghai to meet the increasing demand for more dubbed foreign films which had become a welcome part of its cultural life. Like Germany and some other countries, China is a "dubbing country" by tradition with virtually no 'foreign language' from the mouths of characters on the screen in cinemas or on television except for a very limited releases of subtitled English-speaking films, mainly used during foreign film festivals or broadcast for foreign language education purposes - dubbing being the predominant solution to the language barrier. The major reasons behind this sweeping national practice came

from both above and below: nationalistic language policies, the general literacy level of the viewing population and the attitude towards subtitling adopted by the audience as well as film translation professionals in general. But the scene has begun to change. Since the post-Mao Opening and Reform that started towards the end of 1970s, importation of foreign language media products has been multiplied with each passing year to meet the growing need of an enormous audience in this country for more *yizhipian* (translated foreign cinematic or TV presentations). It is not surprising, then, that subtitled programmes have been occasionally and will be more frequently pressed into service for general TV viewers, even though local dubbing teams have mushroomed from almost all television broadcasting stations in the major cities throughout the country. After the two pre-eminent film dubbing manufacturers in Changchun and Shanghai, a third national-level dubbing studio was born out of the Beijing Film Studio and quickly became a very popular dubbing 'superpower' in China. American movies and TV series have found a huge theatre to make known to millions of ardent viewers their characters speaking in standard Chinese. On 27th June 1993 the China Central Television (CCTV) started to broadcast the Chinese-

speaking version of *Dynasty*, over 200 episodes of which had then been dubbed in Mandarin. Other popular American soaps dubbed by the TV stations in different cities included *Dallas*, *Hotel*, *Falcon Crest*, *Hunter*, to name just a few.

In November 1994, a major reform was effected in China's film import policy: quality over quantity. For the first time, the official China Film Distribution Corporation purchased, in apportioned payment by box-office sales, ten American big-budget movies⁵. In 1995 the translated versions of these Hollywood "mega-movies" were shown to the Chinese audience, concurrent with their release to the world market. As a result, "China's cinemas are having their best ticket sales ever with the help of Hollywood movie imports and a revival in the domestic film industry, ... Last year [1995], the government started to allow public cinemas to show ten top foreign films." (Item 7, CND Global News, January 23rd 1996)⁶. The Chinese film authorities decided in the same year to continue importing and translating ten top films per annum that represent the best of the world cinema of the year. On 23 May 1996, among the ten 1995 big hits, *Zhenshide Huangyan* (*True Lies*) won the 1995 Huabiao Award for Best Dubbed Foreign Film, one of the

government annual film awards; whereas the same prize for the 1996 translated film was presented to the Oscar epic *Yonggande Xin* (*Braveheart*) dubbed in Mandarin Chinese. Being a more enthusiastic importer of foreign audio-visual media products (mainly from America), China is confronting an unprecedented challenge from a great influx of foreign language films and TV programmes each year to present them to its viewing public with a different dialogue soundtrack in an amazingly timely manner⁷.

1.2 Problems

Interlingual dialogue translation in feature films and TV dramas is a common phenomenon of cultural life in many countries throughout the world. Viewers of dubbed or subtitled films or TV fiction are used to expressing unhesitating opinions as to the quality of the translation products. While overall enjoyment from watching them can be experienced in most cases, there is a widespread dissatisfaction with aspects of the language transfer.

1.2.1 In general

Failure to convey certain function(s) of the original film dialogue reveals itself in problems found in the dubbed dialogue and subtitles. These problems, though manifold, all bear the same stigma: unnaturalness. Complaints and criticism often include remarks about "enjoyment being impaired" due to the unskilled translation, or the translated version is "...not much more than a rather contrived imitation of the well-known original..." (Kilborn 1992:114). In reality, picking fault with mistranslated or mismatched subtitles on a multilingual TV channel has been a common occurrence worldwide. But dubbing seems to bristle with more problems. Luyken et al (1991:218) pointed out, "...majorities in favour of statements such as 'the voices sounded as if they had been recorded in a studio and not on location'. Crampton (1989) personally finds "dubbed speech invariably comic, whatever the content," and so "it's obviously a difficult area". Three common types of problems are identified in the English-to-German text for revoicing as: word-for-word translation or "Anglicisms" (Herbst 1991:159), incongruous style or "unmotivated shifts of style" (id. 1995:264) and "lack of text structure" (id. 1987:21) in "that linking elements such as deictic

words or pronouns are either missing altogether or that their textual references are totally unclear" (id. 1995:266). The latter two of these problems account mainly for why the "scripts read like written language and not at all like spoken language" (id. 1991:159).

1.2.2 Problems in film dialogue translations in China

Broadly speaking, apart from a limited number of excellent film translations made each year that can cheer the more sophisticated viewers, most of the products are of low translation quality, unfaithful to the original dialogue to varying degrees. Despite the vigorous criticism sometimes received, most translation blunders are covered up by the cinematic myth that the foreign way of talk is different in the way as represented.

As mentioned earlier, in the case of English-to-Chinese film translation in mainland China, dubbing has been the predominant solution to the language barrier facing the multimillion viewers, while subtitling is called for only on certain occasions in spite of the promise it shows of becoming more than a subsidiary aid to the Chinese audience. Despite the vigorous accumulation of empirical as well as theoretical findings in this field around

the world, the process and quality of the 'solutions', not without lingering problems, have never aroused any research interest in the Chinese translation circles so far.

1.2.2.1 Dubbing

Contrary to the popular belief among the Chinese audience, quality dialogue translations for dubbing are achieved only occasionally by the more prestigious film dubbing studios. The majority of the dubbed screen products (especially those made for television) suffer unnecessarily due largely to the translators' taste as well as haste, as does the audience whose deserved enjoyment has been impaired without even knowing it. Apart from loss, confusion and distortion in meaning, artificiality is an outstanding problem. A stilted high-sounding form of talk has long been the stereotype of the Chinese dubbed dialogue, which is characterized by a stagy enunciation delivered in an exotic announcing or didactic tone, constantly meant to be witty, aloof or emphatic and, every so often, breathlessly verbose. One could easily blame the monolingual dubbing directors and performers for their simplified interpretation of the "Western way of talk" as such, but the source of this pervasive and undesirable "foreignness" may well be traced

to the poor translation scripts which set the frame for the revoicing.

Most of these translation problems might have been avoided if the translator had adopted a different approach to the English-to-Chinese film dialogue translation, in which the original linear presentation of semantic content in each dialogue segment, together with the prosodic features which mark the timing and locus of the information focus within, must be retained into the target language. Therefore, most of the conventional English-to-Chinese translation strategies dealing with structural conflicts between the two languages, such as transposing the lexical items, reversing the word order or even transforming the whole sentence layout to achieve translation equivalence without being bound to the otherwise "un-Chinese" syntax, do not work for this special type of translation. With a major shift of a unit on the grammatical rank scale, be it a phrase, a group or a clause, from the original position to an anterior or posterior one, the information flow of the dialogue spoken is upset, as is the new information focus in each unit. Consequently, the close and constant match of the word stress in the dialogue and the visual code in the picture is out of synch.

This is where the main problems of film dubbing in Chinese are generated⁸.

1.2.2.2 Subtitling

In China, subtitling for English language films is normally done out of sheer expediency. Its professional standards tend to be underrated because of the preoccupation with dubbing – the subtitled version becomes basically a by-product of the dubbed copy of the same screen fiction. It is a widespread practice in China that where there is need to subtitle a film, the dialogue script for dubbing is used simply as the bulk of the would-be subtitled version with only slight omission of function words in those parts where the dialogue segment (usually a sentence or a semi-sentence) can not fit in a caption of a maximum of 13 Chinese characters, which is the allowable limit of wordage for a line of subtitle for the TV screen (two-liners are rarely used in China). The outcome then is disastrous. The subtitles are not only long and heavy, but they keep rolling over and over at the bottom of the screen at very short intervals to catch up with the part being said. Such subtitled films add more pressure than pleasure to the enjoyment of the viewer because they have to watch the pictures AND read and understand, at the same

moment, the words, which are virtually a fully-detailed translation of the characters' speech presented in such a way that the viewer can easily miss the most important information in each of the over-stuffed fleeting subtitles, and worse still, get completely lost in the middle of the movie discourse'. As can be anticipated, in keeping abreast of the on-going voiced dialogue, the subtitles produced as such turn out to be a rapidly displayed lengthy, stilted transcript of the dubbed dialogue. Causing eye-strain and perhaps nerves strain as well, such subtitles contain too much information yet provide too little, for the information structure of each dialogue segment is confused and the covert prosody of the written lines obscured, so that their purpose of serving to re-capture the functions of the original English dialogue for the Chinese-speaking audience has been greatly frustrated. However, since subtitling in China derives from dubbing by and large and so do most of the translational problems, the quality of English-to-Chinese subtitling may be expected to improve significantly subject to a revolution in our approach to film dialogue translation, which leads to a breakthrough in finding ultimate solutions to the dubbing problems.

1.3 Purpose and Organization of the Study

1.3.1 Aims of the thesis

The matters raised above compel a look at film dialogue translation in a new perspective. This means there is necessity of initiating a fundamental change of the traditional approach to film dialogue translation and the age-old methodology, which treats dubbing and subtitling as a script-to-script business without distinguishing it from other types of translation; for example, without translating the intonation of the source language dialogue into the target language. Ignoring the transfer of the embedded prosodic functions from SL to TL in FDT yields an incomplete translation at least, and in most cases, a misleading one (especially in dubbing), in the sense that such translation products are functionally and stylistically vulnerable to confusion and loss of meaning, because of failure to observe the basic laws of spoken language translation as applied in FDT.

In order to help improve this situation and inform screen translators in China, the present study aims at working towards establishing a pragmatic model for defining effective and efficient translation procedures for dubbing from English to Chinese, as

well as for describing and evaluating the quality of the finished translation products. It will also attempt to justify a hypothesis in theory that the current practice of transplanting segments of translated dialogue lines for dubbing into the designated screen slots for subtitles should work satisfactorily, provided the dubbing script is done as a corollary of the new translation approach and the specific media characteristics and constraints of subtitling are well heeded.

Such a model of potentially dual functions needs to be based on a theory which sets its objective on anatomizing spoken and written language into units of information and explicating how they each reflect the influence of discourse factors on grammatical patterning including prosody. This is exactly where the functionalist approach to information flow can come in to help.

Rather than claiming for my research topic the whole territory of film translation between English and Chinese, which actually calls for a joint effort of experts in a wide range of fields, this thesis is primarily concerned with English-to-Chinese screen drama dubbing with special reference to the translation quality of dubbed audiovisual

products that represent the state of the art in China. A new approach to film dialogue translation in general, and dubbing in particular, will be advocated which was inspired by the findings on information flow in spoken and written language in the tradition of functional linguistics. As the main input in my translation model, I will adopt the analytical system and its theoretical framework developed by Wallace Chafe in his work on speaking vs. writing (see Chafe 1994 for a book-length overview), with the intonation unit (IU) being an effective instrument for practical purposes of processing film dialogue scripts.

In an attempt to introduce a pragmatic solution to the burning issues in dubbing (and subtitling) in China, I will experiment on the proposed model in a test case by using an American mini-series for television with its Chinese-dialogued version as the main data for analysis. In the process of proposing and testing the focal theory of this study, I will outline the ways in which such a theory can be fully developed and validated so that film dialogue as an instantaneous audio-visual discourse can be better manipulated and rendered into a foreign language in the dimension of what is termed "textual equivalence" (Baker 1992), "dynamic equivalence" or "functional

equivalence" (Nida 1964; Newmark 1991) and "communicative equivalence" (Brondeel 1994).

As the thesis will show in the final analysis, the intonation unit is the most appropriate unit of segmentation in processing film dialogue in translation and intonation operates as a sensitive index of a film's discourse and, when appropriately employed, can provide a basis for minimizing cross-linguistic discrepancies and compensating for loss of meaning/rhythm in screen language transfer, especially where conflicts arise between the constraints of grammar and the adequate conveyance of cultural-specific content and style.

The basic objectives stated above lead to specific concerns as to how to clarify the complementary relationship between spoken language analysis and spoken language translation in the incremental discourse processing perspective and how, as a point of entry, it can lead to bringing about good quality translations for the media in the dubbing mode. Pertinent questions which the present study is going to address include the following:

- ▶ Why does film dialogue as the object of dubbing and subtitling deserve sociolinguistic scrutiny? How should film dialogue translation as a genre of

translation benefit, but be distinguished, from other types of translation and studied effectively?

- ▶ To what extent are the film/TV drama and stage drama comparable as well as irreconcilable, as far as translation for cross-cultural performance and communication is concerned?

- ▶ What is the relevance of functionalist theory on information flow to film dialogue translation? In what connection is the basic principle of Analysis-Transfer-Synthesis model(s) as applied in MT and NLP built on the information flow theory?

- ▶ What is the correlation between information focus and the intonation of film dialogue? How important is the prosody factor in dubbing?

- ▶ What should be the appropriate translation unit in film dialogue translation? Is employing the intonation unit as UT a superior and more practical procedure than the sentence-based or scene-by-scene translation approaches?

- ▶ How does Mandarin Chinese use intonation features such as rhythm and stress as primary cues which are comparable to those in English to reflect information flow and intonational meaning? How is it possible by attending to this factor to arrive at a

higher dimension of translation equivalence between so distant languages as English and Chinese to achieve the optimal effect in dubbing?

- ▶ Since FDT tends to have a foreign ring to the receptor viewer, which is both inevitable and necessary, what is the allowance of this 'foreignness' in the TL representation of the characters' speech? Should the translator strive for the effect of "sending the audience abroad" by avoiding domesticated-sounding ways of speaking or should care be taken not to foreignize the TL dialogue? What is considered as good style of film dialogue translated from English to Chinese?

- ▶ Is SL-oriented translation necessary for achieving the desired style in dubbing? Is literalism an appropriate translation strategy in FDT?

1.3.2 Plan of the thesis

The entire thesis consists of six chapters.

Chapter Two will attend to the theoretical groundwork for the present study. It is divided into 3 parts pertaining to film dialogue and film dialogue translation. First of all it will set the scene by examining FD as the object of FDT from a sociolinguistic point of view. Through reviewing studies in dramatic dialogue in the field of

discourse analysis and their relevance to the analysis of FD; and identifying the nature and property of FD in the three dichotomies of sociolinguistic interpretation, viz., form and function, speaking and writing, and planned and unplanned discourse, the place of FD as a distinctive discourse type, as well as a special genre for translation, will be established.

The second part will be devoted to a general review of literature on the contemporary translation theories that have either related to or shed light on FDT, especially those concerned with drama translation.

In the final part, the chapter will provide a brief survey of research in film dialogue translation, focusing on the place of FDT as an established subject in TS and the linguistics-informed research on subtitling and dubbing in recent years. It will be followed by an in-depth look at the state of the art in China, with special reference to dubbing from a foreign language into Chinese.

The needs for theoretical input in FDT will become evident after the survey of the previous work in these fields.

Chapter Three will review some promising models in the tradition of functional linguistics that may offer solutions to the FDT problems. It will mainly work towards the theoretical framework of the thesis, with Chafe's cognitive model of information flow (Chafe 1994) being the focus.

Chapter Four will formulate our focal theory on FDT prior to the interpretation and description of the methodology used in this study. Viewing in the context of FDT, it will zoom in on the five main issues in TS regarding the relations between top-down and bottom-up translation perspectives, foreignizing vs. domesticating TLT, the unit of translation, the levels of translation equivalence and the criteria for quality assessment of translation. In discussing these issues in the IF perspective, the stylistic features and three basic functions of FD and their implications for dubbing will be clarified; and the meanings of FITness of the representation of the original form and function in TL will be re-defined and illustrated. The translator's important role and potential power in the process of FDT will also be re-estimated.

The second section will dwell on the presentation of our intended theoretical contribution culminated in a dynamic translation model (FITNIATS) for English-to-Chinese dubbing in the context of a systematic mode of translation/evaluation procedure, which is potentially applicable to subtitling as well.

Chapter Five will apply the theory developed in the previous chapters to my research data. It will be concerned with a case study of a TV series dubbed from English to Chinese. This Chinese version will be compared with another one of the same television drama, which is a demonstration by itself of the desired result of implementing the FDT methodology advocated in this study in the process of its translation. A statistically supported discussion on the translation quality in the three samples from the problem translation will be followed up on the results of the comparative analysis at the end of each speech act sequence as well as the end of each sample. A general summary of the findings from the entire test case and a statement of the translation quality of both Chinese translations will be delivered at the end of the chapter.

Chapter Six will discuss the implications of this study for subtitling. By identifying subtitling as a special type of spoken language translation and redefining its relationship with dubbing, the applicability of the FITNIATS model to subtitling will be focused on with illustration.

Finally, Chapter Seven will conclude the study by evaluating the effectiveness of the model as applied and confirm our hypothesis that FDT should be a SL-oriented translation so that it is highly necessary and most appropriate to use the intonation unit as the UT and transfer the prosodic message faithfully in the original FD. It will also offer recommendations for further research.

Chapter 1

NOTES

1. Over the last few years, **screen translation** has become a convenient cover term of growing currency for both translation of feature films and television dramas.

2. Film dialogue as a distinctive discourse type refers to the human verbal interaction (dialogue) in both feature films and television dramas. It was established as a sociolinguistic genre in Li (1987). Also in the article, the word **film** is used in a categorical sense covering teleplays and TV drama series as well as feature film shown in the cinema or broadcast on television.

3. It is the objective of the film scriptwriter to commit FD as purposeful human speech to the maximum degree of verisimilitude while eliminating all the unnecessary words to achieve the best dramatic effect under the medium constraints. This double task is realized by means of exercising the "dramatic economy" (Armer 1993:122) on top of the "economy of information flow" (Chafe 1992b:293) that conditions the information density of spoken language.

4. See 2.5 of this thesis for a detailed account of this topic.

5. These ten movies are *Forrest Gump*, *The Lion King*, *True Lies*, *Speed*, *The Fugitive*, *Die Hard III*, *Rumble in the Bronx*, *In the Line of Fire*, *Water World* and *Apollo XIII*.

6. *The Fugitive*, for example, was the first one to be premiered in 1994 in metropolitan Beijing, Tianjin, Shanghai, Guangzhou, Zhengzhou and Chongqing simultaneously, totalling 4,000 shows with the number of audience turnout being 1.37 million and box-office earnings 11 million Yuan (YI Xudong 1997:1).

7. See 7.4 on the 'Titanic Phenomenon'.

8. Here are some examples to show how in common practice certain lexico-grammatical constituents of the target language (Chinese) have to be arranged in an order very different from that of the source language (English) in turning the meaning into idiomatic Chinese. Unfortunately, the TL renditions below would have read like one if they were not actual dialogue lines dubbed for the teleplay.

(1) (*A Woman Named Jackie*: Sc. 1-4.4)

SL: I don't give it a damn if he wrote in Sanskrit.

TL: Na³pa⁴ ta² yong² fan² wen² xie², wo³ ye³ bu⁴ zai⁴ hu.

(2) (*A Woman Named Jackie*: Sc. 1-7.1)

SL: (a) I do believe ⁽¹⁾married life agrees with ⁽²⁾you.

(b) And I've got to write a ⁽¹⁾policy statement ⁽²⁾on better Negro education.

TL: (a) Wo³ xiang² xin² ⁽²⁾ni² neng² shi² ying² ⁽¹⁾hun² hou² de sheng² huo².

(b) Wo³ ye³ yao⁴ xie² yi² pian² ⁽²⁾guan² yu² gai² shan² hei² ren² jiao² yu² de ⁽¹⁾zheng² zhi² bao² gao².

(3) (*A Woman Named Jackie*: Sc. 2-2.1)

SL:

(a) I would have been miserable anyway.

(b) I ⁽¹⁾don't ⁽²⁾think there are any men ⁽¹⁾who are faithful ⁽²⁾to their wives.

(c) Men are such a combination of good and evil.

TL:

(a) Bu`guan`zen`yang`, wo`de sheng`huo` shi` hen` tong`ku` de.

(b) Wo`⁽²⁾ren`wei` ⁽¹⁾mei`you` yi`ge` nan`ren`⁽²⁾dui`qi`zi` ⁽¹⁾shi`zhong`shi` de.

(c) Nan`ren` dou` shi` shan`yu`e`de`lian`he`ti`.

(4) (*A Woman Named Jackie*: Sc. 3-1.8C)

SL: I want you to remember that one night you slept in the bed he slept in when he was President of the United States.

TL: Wo` yao` ni` ji`zhu` ta` shi` Mei`guo` zong`tong` shi`, ni` ceng` zai` ta` chuang` shang shui` guo.

Idiomatic as they may sound, they are problematic translations for the screen.

9. The sample cited below is from the subtitled version of the American film *The Silence of the Lambs*. The subtitles are mere clippings of the dubbed version of the same film (sometimes with slight reduction and/or change of words), both made by the translation team of the Beijing Film Studio in 1991.

(*The Silence of the Lambs*: Sc. A1 - 6)

CLARICE

I'm only asking you to look at this, Doctor.

[Sub] Wo zhi shi qing ni kan kan, bo shi.

[Dub] Wo zhi shi qing ni kan kan, bo shi.

Either you will or you won't.

[Sub] Ni ke kan ke bu kan.

[Dub] Ni ke kan ke bu kan.

DR. LECTER

Yes.... Jack Crawford must be very busy indeed

[Sub] Ke luo fo de yi ding shi mang de bu ke kai jiao le

[Dub] hao... Jie ke Ke luo fo de yi ding shi mang de bu ke
kai jiao le

if he's recruiting help from the student body.

[Sub] Zhi hao cong xue sheng zhong zhao ge ren lai bang mang.

[Dub] Zhi hao cong xue sheng zhong zhao ge ren lai bang mang.

Busy hunting that new one, Buffalo Bill...

[Sub] Ta mang zhe zui bu nei ge ye niu Bi er.

[Dub] Ta mang zhe zui bu nei ge ye niu Bi er.

Such a naughty boy!

[Sub] Rang ren tou teng de hai zi!

[Dub] Rang ren tou teng de hai zi!

Do you know why he is called Buffalo Bill?

[Sub] Zhi dao ta wei shen me jiao ye niu Bi er ma?

[Dub] Ni Zhi dao, ta wei shen me jiao ye niu Bi er ma?

Please tell me. The newspapers won't say.

[Sub] Gao shu wo bao shang ke mei you shuo.

[Dub] Kuai` gao` shu` wo` bao` zhi` shang ke` mei` you` shuo`.

CLARICE

Well, it started as a bad joke in Kansas City Homicide.

[Sub] Kai` shi` shi` liu` chuan` zai` Ken` se` si` de shuo` fa`.

[Dub] Erm...ai` shi` shi` liu` chuan` zai` Ken` se` si` jing` cha`
ju` de shuo` fa`.

They said.. this one likes to skin his humps.

[Sub] Ju` shuo` you` ren` zong` gei` lie` wu` bao` pi`.

[Dub] Ju` shuo` you` ren` zong` gei` lie` wu` bao` pi`.

DR. LECTER

Why do you think he removes their skins, Agent Starling?

[Sub] Ni` dui` ta` bao` pi` shi` zen` me kan` de, Si` te` gong`?

[Dub] Ni` dui` ta` bao` pi` shi` zen` me kan` de, Si` da` lin` te`
gong`?

CLARICE

It excites him.

[Sub] Ta` jue` de ci` ji`.

[Dub] Ta` jue` de ci` ji`.

Most serial killers keep some sort of trophies from their victims.

[Sub] (1) Da` duo` shu` sha` shou`

(2) yao` cong` shou` hai` zhe` shen` shang na` dian`
shen` me.

[Dub] Da` duo` shu` sha` shou`, yao` cong` shou` hai` zhe`
shen` shang na` dian` shen` me.

The last sentence of the dialogue excerpt above was cut into two lines for the subtitles which were displayed separately in the film frame within the time allowed. This is a common strategy to treat long lines of the dialogue in putting them into Chinese subtitles, and this is where the most undesirable problem in subtitling arises.

Chapter 2

THEORETICAL ORIENTATION: FILM DIALOGUE AND FILM DIALOGUE TRANSLATION

PART ONE: FILM DIALOGUE AS A DISCOURSE TYPE

2.1 Preliminary Review

While being necessarily kept to a minimum, dialogue in a screen drama is indispensable. Its supporting role in a film can be crucial to the communication between the film maker and the consumer through the film medium, especially in a cross-cultural setting. When the intelligibility of this most important auditory code is denied to the TL audience, either because of the failure of translation or extraneous factors that prevent the proper reception of the translation, the whole meaning of their involvement in the activity as the communicatee is put in jeopardy. This demonstrates in reverse how film dialogue translation counts as the enabler of interlingual communication. Setting its objective on the simultaneous language transfer in the service of the TL audience who depend on dubbed dialogue or subtitles to comprehend a film, film dialogue translation is a special type of translation in that it is not simply a text-to-text

nor speech-to-speech translation; rather it is a blend of translation and interpretation realized through an artistic as well as linguistic recreation under multiple medium constraints. Obviously, it requires that the dialogue translator be properly trained in the methodology and translation skills appropriate for this relatively new subject in the field of translation studies, with the proviso that he possesses an inside view of the *object* of his work, i.e., film dialogue, to start with.

2.1.1 The Long-overdue Task

Film dialogue has always been relegated to an inferior position by film producers and theorists. This phenomenon is summed up by Devereaux (1986:32-33): "Sound is neglected by film theorists more than any other element of film, dialogue more than any other element of sound." and "...despite more than fifty years of technological developments since the end of the silent era, the analysis of sound lags behind the analysis of the visual image.....". She then classifies into three groups those theorists who do discuss sound and concludes that all agree that dialogue does not belong to the cinema. Concentrating on two issues: possible theoretical justification of sound's subordination

to the visual elements of film and that of dialogue's status as a "purely theatrical" element of film, her argument rounds up with these statements: "... words, in film as elsewhere, function in a variety of ways other than to describe" and "...film dialogue demands serious attention. ... Because screen dialogue has developed its own rules and principles, it cannot be dismissed as theatrical." (pp.48-49). In another article in defence of film dialogue, Shadoian(1981) also stresses the multifarious shadings and functions of film dialogue, viewing every instance of dialogue as a means of enhancement and arguing that it "can indicate or emphasize space, distance, setting, etc., as well as create highly nuanced emotional/psychological ramifications ...and there is no need to draw it out further." (p.86). Neither the flurry of post-modernism nor the revival of interest in the New Wave will be able to diminish the continued (and perhaps intensified) role of film dialogue that appears and functions in all sorts of films.

So far, film dialogue as a subject of media discourse analysis has received only initial effort and attention, partly because it is a relatively new discipline. Little has been spotted in this

particular area except for some convergent theories of peripheral relevance to the analysis of specific cinematic texts, such as Bakhtinian Translinguistic approach which offers a socio-ideological view to cine-semiotics but contrasts the latter by focusing on textual connectedness as achieved by cohesion and coherence (see Palmer 1989). According to Mikhail Bakhtin's theory of dialogic meaning, the literary meaning of cinematic texts is treated as part of social action and should be rendered in such a way that it sounds incrementally exchanged and constructed. The analysis of mass media discourse has tended to become a cross-disciplinary concern, especially in close linkage to media-semiotics and communication studies. Text analysis of news, interviews, and advertisements has been initiated, whereas that of feature film text is still far from being 'caught up in'. However, the methods of audio-visual analysis as employed for other genres of media discourse can be useful for the feature film text.

Primarily aimed at setting out "a framework for analysing media language ... to persuade readers ... of the value of analysing mass media linguistically and in terms of discourse" (Fairclough 1995:3), Fairclough in his comprehensive study of media

discourse identifies two major categories of contemporary media language in terms of the social function. One can be called "public affairs media" (id:10) meant to provide information in official voices and the other is "designed as entertainment (drama, soap operas, comedy shows, quiz shows, and so forth)" (ibid.). As he illustrated in his analysis of an extract from a BBC television programme entitled 999 which features dramatic re-enactments of true life rescues, the boundary between information and entertainment is relaxed and shifting, showing the tendency in the change of the internal structure of media discourse in recent years to move in the direction of the more private-oriented or dramatized side across the unstable divisions of fact and fiction, documentary and drama, on-camera account and conversationalized re-enactment (id.:169-175). According to his definition, the entertainment media output seems to be marked by "conversational language" (p.12), "lifeworld discourses, discourses of ordinary life and ordinary experience" (p.164), "the voices of ordinary people" who "generally tend to speak personally...not officially" (p.172) and "dialogue" (Ch.8:passim). However, here film dialogue has not been considered separately to be a special sub-genre of the language of entertainment.

On the other hand, media discourse study is still embryonic in China². It is true, though, that film dialogue has been attended to by Chinese film artists and script writers, who treat it only as a subsidiary expressive element of motion pictures, and by the literary critic, who is primarily concerned with the messages that the meanings of words "convey in particular instances of use" (Widdowson 1975); however, none of them are interested in the language itself: how this stylistic variety exemplifies the language system or how the study can contribute significantly to film dialogue translation in China; on the contrary, the latter generally regard it as utterly irrelevant.

2.1.2 Search for relevance

The virtual exclusion of film dialogue from modern linguistic analysis could be seen as a universal phenomenon (Burton 1980:3,93,168). To help solve the aforementioned problems by introducing this overlooked subject into the realm of linguistics is of pragmatic significance for film dialogue translation. The necessity in principle was justified by Halliday as early as 1964:

It is part of the task of linguistics to describe texts; and all texts, ..., are accessible to analysis by the existing methods of linguistics. (p.192)

And in McIntosh & Halliday (1966):

But if a text is to be described at all, then it should be described properly; and this means by the theories and methods developed in linguistics, the subject whose task is precisely to show how language works. (pp. 67-68)

In Halliday's view, the perspective differs in that language is looked at and linguists' treatment of a piece of literary writing, prose or verse, as text is one which leads to objective and verifiable judgment, because it is science-based. Since "non-poetic dramatic dialogue may sometimes be classified as merely another type of prose" (Burton 1980), this proposition should apply to film dialogue studies.

The conventional kind of dialogue description relies more on the analyst's values and intuition and, even more on the individual's ability to appreciate the literary representation. The linguistic model developed by Crystal & Davy (1969) and Toolan (1985), the stylistic analyses exemplified by Burton (1980), Leech & Short (1981)

and Ferrin (1992), and the linguistic criticism theories on dialogue represented by Fairclough (1995) and Fowler (1986), seem to be more convincing and reliable, since they are largely restricted to rule-governed interpretations on the level of discourse in terms of its deviation from a norm. Written dyadic speech as a readily definable variety so examined results in adequate comprehension and constructive evaluation, for the simple reason "that a detailed analysis of authorial technique and stylistic features can be more successfully achieved within a rigorous linguistic framework." (Coulthard 1985). As discourse analysis has become increasingly genre-specialized, the absence of film dialogue from the sphere of its theories and applications deserves serious queries.

2.1.2.1 Earlier Investigations Into Stylistic

Features of Conversational Discourse

Three linguistic streams representing pioneering efforts to apply stylistic/discourse analysis means to the study of conversational discourse (non-literary, dramatic and fictional) shed light on the orientation of further research in this area.

Understanding Spoken Discourse

The linguistically oriented approach developed by Crystal & Davy (1969, 1975) is a necessary theoretical preparation and a practical methodology for applying stylistic procedures to dramatic discourse. By scrutinizing the situation-bound linguistic differences (or 'variety-markers') which characterize the main varieties of non-literary English and by understanding the restrictions on their use, it aims to replace a sporadic approach with a systematic one to the clarification of stylistic effect and to minimize the intuitive element in criteria of analysis. It is a procedure which provides a set of clear techniques for describing any piece of language and "will focus the attention on all that is interesting in a piece of language and ensure that no item of potential significance is overlooked". (Crystal & Davy 1969:14) This operational view is exemplified by their initial effort to distinguish a wide range of language varieties with highlighted anatomy of informal conversation, in terms of situational categories (such as formal, informal, religious, legal, etc.) within different dimensions (such as province, status, modality, etc.) --- a switch in the categories at any one dimension produces a different variety. The categories in turn are

defined by stylistically distinctive features in terms of a number of interrelated levels of description, e.g., phonetic/graphetic, phonological/graphological, grammatical, lexical, and semantic levels. Thus for every feature a two-fold description is given, e.g., a phonological feature of province, a grammatical feature of status, and so on. Therefore, all features of all texts in a language can be compared and described in the same basic framework. (ibid.:83)

Crystal & Davy have classified the varieties into types within the repertoire of English, each being definably distinct from all the others, yet "the same techniques and procedures could be used for the stylistic analysis of other languages". (ibid.:vii) Although they have not tried to group varieties into more general types, their concern with the dichotomy between spoken and written language has opened up an avenue of scientific research in sociolinguistics. For pedagogical as well as theoretical and procedural reasons, they have maintained their primary interest in the stylistic treatment of actual speech, looking not only at the linguistic and phonetic markers (including prosodic and paralinguistic features - one of their keen concerns), but also

sociolinguistic significance of the conversationalist's tactics and general strategies employed in communication. By organizing their analysis of the conversation data under three general headings, namely, *fluency*, *intelligibility* and *appropriateness*, they examine the conversational interaction comprehensively at discourse level. (Crystal & Davy 1975).

The applicability of this methodology to film dialogue is promisingly wide and direct. Firstly, film dialogue needs to be distinguished as a sub-variety of language from all the other "medium-derived stylistic varieties" (Malcolm 1987), including the other forms of media and dramatic discourse. The universal nature of their methodology should be able to serve the purpose.

Secondly, one of the enlightening ways to study film dialogue is to compare it with real life conversation: what are the common linguistic features and conversation segments that characterize the colloquialism of both types? How much deviation from the linguistic norms of spontaneous conversation is present in film dialogue? To what extent is the non-fluency phenomenon allowed in the 'word-grudging' film

dialogue? These questions can be satisfactorily answered only after one is aware of the normal function of the stylistic features constituting natural conversation , which has been made clear by the useful linguistic apparatus they have provided.

Thirdly, their insight into the problem of how to bridge the gap between the constructed dialogue of teaching materials and the conversation in actual use can presumably be borrowed into maintaining the criteria of rendering film dialogue into a foreign language without losing the original style.

Drama Discourse Analysis

What is called by Crystal & Davy (1969) "the last part of a stylistician's training(p. 80), i.e., the application of stylistic techniques to literature, has been profoundly carried out in Burton (1980), whose work marks the termination of the oblivion of drama dialogue in modern stylistics. To start with, three short dramas have been operated on by the scalpel of conversational analysis based on the Birmingham model, to show "how recent advances in the sociolinguistic description of spoken discourse ... can be drawn on to account for reader and audience intuitions about the dialogue in those texts" (id.: ix) and how useful the instrument of

analysis can be for the stylistician. However, that remains "as only a demonstration of the potential use that the stylistician might make of the ever-growing body of writing on conversational analysis, when discussing drama text." (id:92) The lengthy, meandering analyses of style in drama dialogue as shown in the first section of her work, argued by Burton, can only be a starting-point for a rigorous and comprehensive analysis that must be able to draw on a more accurate and coherent theoretical and descriptive framework for the analysis of all naturally occurring conversation. The model (Sinclair & Coulthard 1975) has been introduced and expanded in the first half of the complementary section aiming at "using simulated dialogue as a means of developing discourse itself" (ibid.) Obviously, the preceding elaborations are meant to prepare ground for offering her own model, closely based on similar principles, "as a contribution to the linguistic analysis of all spoken discourse" (id.: 140) and it is designed to be available as a general descriptive apparatus for anyone with either linguistic or literary interest to use in analysing *all* conversational data, both play-talk and real life talk. She maintains that "Pinter is widely acclaimed by both the lay and the literary-critical public as a notable writer of realistic-

sounding dialogue" (ib.:69), and in Chapter 5 She argues strongly for the view that dramatic text can be used as an authentic source of data for sociolinguistic studies.

On the other hand, Burton concludes from her analysis of Pinter's plays that, a drama text, being shaped with constructed speech sequences, has its own rules and conventions which are different from real conversation in observing Grice's quantity maxim. As she points out, "the characters ... must surely know that they both know and that the audience certainly knows that they know" (ibid.: 13). This reveals the "acted-to-be-overheard" nature of any dramatic discourse with respect to its tendency to verbalize more information than required in the dialogue to fill up the gap of knowledge shared by the audience with the characters.

The linguistic studies of dramatic discourse since Burton (1980) have yielded many new insights to this hardly-trodden area. The outcomes of the research are evidenced in extensive studies in dramatic/literary discourse³. These findings have shown to be of immediate relevance to the study of

drama translation, which will be reviewed in 2.3 of this thesis.

Linguistic Creation of Reality

Later development in the stylistic study of literary discourse is found in the pragmatic description of fictional language by Leech & Short (1981). Proclaiming their method to be of the "new stylistics" which has applied the results of modern linguistic research to this area, they take prose fiction as the object of scrutiny, looking not only at the text, but also *through* the text to its meaning. This approach concentrates on the practical examination rather than theoretical exposition of fictional discourse for the purpose of gaining a richer and more reliable appreciation of what style in fiction is and how it can be usefully analysed.

Holding that there is no 'standard' theory to which one can appeal in applying techniques and definitions of linguistics to the study of literary language, it synthesizes different viewpoints of language, particularly those of Halliday's functional model, Searle's speech act theory, Grice's conversational maxims, and conversational analysis. In so doing, it contributes directly to

an effective interpretation and evaluation of the novelist's speech/thought presentation. Compared with the two approaches aforementioned, it insists on a closer integration of the role of linguist and literary critic, for the reason that "linguistic analysis does not replace the reader's intuition ... but it may prompt, direct, and shape it into an understanding" (ibid.:15).

In so far as film dialogue study is concerned, this approach is effective in at least two respects. First, Leech and Short have successfully defined the relationship between language and the "mock reality" of fiction in functional terms. In their view, the combination of *verisimilitude*, furnished with symbolism, and *credibility*, aided with consistency, is the life and soul of realistic fiction-writing (ibid:158). As an important and special case which is favourable to the view that language can copy reality, the language used to simulate, rather than simply to report, happenings of the fictional world, provides the illusion of real conversation. It "may aspire to a special kind of realism, a special kind of authenticity, in representing the kind of language which a reader can recognize,..." (ibid.:160). This definition and their subsequent description of fictional speech in

comparison with real speech apply to film dialogue study in the main, particularly, the part concerning features of non-fluency in the dialogue of novels and the planning factor in speech delivery (Cf. Crystal & Davy 1969:103-105, 115).

Second, as illustrated by them among the chapters which are devoted to the social dimension of literary discourse, the specific treatment of conversation in the novel embodies illuminating ideas of how fictional dialogue works on the basis of dramatic interest. Through using pragmatic interpretative strategies and the scale of conversational tone to analyse fictional dialogue, they have not only explained and justified the intuitive reactions to it, but also emphasized the two-way motive of such interaction - the dialogue between characters in the novel also being used by the author in his communication with the reader. (Cf. Burton 1980:13). Film dialogue, being of such two-level discourse, falls in with their conclusion that "it is only the greater complexity, multiplicity and subtlety of the novel as discourse which separates it from the most commonplace conversational transactions." (id.:316)

To sum up, a linguistic study of film dialogue would be well informed by the three approaches to examining the relevant varieties of language. They are relevant to one another, because, as real life conversations or literary conversations, they all possess the very basic linguistic characteristics of spoken discourse and, to a large extent, they are governed by the same sociolinguistic principles of conversation⁴. since the ultimate aim of stylistics is to explain the relation between style and aesthetic as well as pragmatic functions and, the best possible way to start with is to identify the text under study as belonging to a well-defined variety, the approaches reviewed above have illustrated such required knowledge.

2.1.2.2 Later Research on Dramatic Discourse Analysis

Subsequent to the appearance of the earlier models of stylistic analysis to literary text, Korpimies (1983) offers another clear example of the continuing attempts to apply the 'Birmingham' Model of spoken discourse (Sinclair & Coulthard 1975) and its application to dramatic texts. Like Burton (1980), Korpimies focuses on another play of Pinter's, looking at patterns of interactional

exchange, such as the speech acts involved and tendencies to use turn-taking in the dialogue. Also taking a lead in part from Burton (1980), Coulthard (1985) makes a stylistic analysis of *Othello* to "illuminate technique in simulated interaction" (id.:192), in which he applies an interactive model derived from conversational analysis to one aspect (question and answer) of the drama text.

Using George Bernard Shaw's comedy *You Never Can Tell* as the data for analysis, Leech (1992) examines the characters' speech in terms of the pragmatic deviance from the Gricean Co-operative Principle and the Principle of Politeness as extended by himself (Leech 1983:104-51). He argues that the concept of poetic *foregrounding* can be applied to drama just as revealingly as to the study of non-literary discourse in relation to the "contextual incongruity" (id.1992:259) and "pragmatic abnormalities" (idib.:269). The un-cooperative and impolite behaviours in the play as detected by Leech "reveal the richness and significance" of the play's own strategy of using poetic deviation. His analysis shows that the application of pragmatic principles can help explain the plot development, characterization and different conversational styles of a play.

Impressive work on discourse analysis in stylistics, particularly in dramatic literature, is documented in Short (1981-1994). His active contribution to this field is more evident in three respects. First, he has distinguished three major literary genres, viz., poetry, fiction and drama, in terms of their prototypical discourse structures (Short 1981). Particularly revealing is his theory on the 'double' nature of drama discourse (Short 1989a; details see 2.1.3). Second, his survey in the field of discourse analysis and drama (Short 1990, 1994) is insightful and comprehensive in that he offers detailed summaries and bibliographies of the topics and findings in the field. Third, he attaches importance to using discourse analysis of dramatic dialogue for testing theories about real conversation and using stylistic approaches in the teaching of language and literature (1989a, 1989b, 1990), and has achieved this dual purpose satisfactorily. As he set out to prove, "[t]he comparison of dramatic texts with recorded conversation could be used as a way to highlight what goes on in casual conversation. The discussion of what is meant, implied, etc. by characters in dramatic dialogue can also be used in class to make

students explicitly aware of the communicative nature of discourse." (id. 1981:200)

Focusing on the discourse analysis of deixis in dramatic text, Stapele (1990) concludes that deixis in drama as a basis of the creation of performances defines the dramatic world which consists of both "the communicative context of the characters which occurs in the larger context of our reality" and the subworld, i.e., "the physically concrete world he [the playwright] wants to establish on stage" (id.:334). He shows this powerful role of deixis in a drama by demonstrating how the dramatic world is created in the text which is based on the deictic markers as the main cues. His analysis covers different types of deictic words that indicate the personal, spatial, temporal and topical reference. The method he uses is functional in orientation and makes explicit how deictic strategies involving anaphoric reference, speech turns, non-verbal behaviour (posture, touch, distance and movement) regulate the articulation of the speech acts. He segments and tabulates a dramatic text in such a way that the dynamic of the drama in the text becomes perceptible.

Stepele has highlighted the importance of deixis in drama successfully by applying an operative approach to the rendering of the boundaries of the dramatic world in a practical and lucid manner. His analysis spells out the semantic and semiotic functions of deictic indices in a drama, which can be related to the study of film dialogue. As he claims, the method of deictic analysis of dramatic texts he presents can also be applied to the text spoken in a film, "e.g. for comparing the use of verbal deixis in a performance with the use of (aspects of) other sign-systems, such as movement and gesture." (id.) However, his system could have been more substantiated by including explication of dramatic discourse in the pragmatic dimension (e.g., the analysis of deictic centering in drama as formulated by Doty 1984).

Other unconventional approaches to drama discourse analysis are represented by Hess-lüttich 1985, Birch 1993 and Tenner 1994. Hess-lüttich (ibid.) takes a macro view of the pragmatic analysis of dramatic discourse through examining existing problems of interpreting such basic issues concerning dramatic communication as the basic constellations of literary discourse, the relation of factual and fictional discourse, types of

dramatic discourse and its medium and rhetoric. He summarizes, the typical features of fictional conversation (lack of deficiencies of syntax, hesitation phenomena, redundancies, overlapping of turns, etc.) can shed light on the global structures of discourse regardless of the factual and fictional distinction in terms of authenticity. The relationship of fictional dialogue and the reality, in his opinion, should be accounted for in the analytical procedure that consists of a hierarchy of levels including the one of "its adaptation in other media such a film, television, video etc." (id.:205). Birch's approach to drama text analysis (ibid.), on the other hand, is based on critical linguistics and social semiotics. He focuses on the functions of deixis in establishing power relationship in dramatic performances through the customary use of the deictic strategies as reflective of dialogic imperative and shared knowledge status which can be compared with any social interaction.

In a chapter co-authored with R. T. Lakoff⁵, Tannen (1994) probes into the question of the relationship between artistic verisimilitude and the reality by offering a detailed example of how the use of fictional dialogue for linguistic analysis can

interpret an internalized schema for the production of conversation. They analyse an English translation of a televised Swedish drama to discover each character's preferred conversational strategies and how the choice of forms and the effects of these forms can represent deeper levels of pragmatic structure. Lokoff's theoretical system modelled on a four-point communicative framework is applied to understanding the characters' speech styles as being *distance*, *deference*, *camaraderie* or *clarity*, or more or less on the continuum. Three linguistic devices replicating the basic semantic relations are adopted for characterizing the speakers' verbal strategies operating alternatively on three corresponding levels of the interactional process, viz., *pragmatic synonymy*, *pragmatic homonymy* and *pragmatic identity*. The purpose of their study, similar to some other studies under review, is directed towards discovering an ideal model of conversational strategy and metastrategy rather than distinguishing the language of dramatic discourse per se.

Kachru (1992), in justifying the authenticity of the fictional speech from the two Indian English novels when used as data for the research on cross-

cultural speech act, concludes that, "[i]n so far as conversations in literary works have to 'ring true' to be convincing, creative literature can be a valuable source of data for speech act research." (p. 236) Also using theatrical plays to be the main source of data for her sociolinguistic research, Sifianou (1992) contends that modern literature, particularly plays, is "a mirror of society" which "reflects and portrays a great variety of people" with "their use of language..., ...their attitudes and values about language itself", and as such "can be a rich source of natural data and of powerful insights into everyday conversational structures". She believes that plays, representing actual speech, are not "an example of the written mode, because they are obviously intended to be performed (spoken) rather than to be read". She then points out "[m]any plays have never even been published"..., so "it should be clear ... that there is literature which is meant to be read and literature which is meant to be heard, and plays definitely belong to the latter category" (quotes from ib.:5-7). The phenomenon described here also applies to the film dialogue genre and perhaps even more so, for screenplays are "simply a way of recording the spoken language in an enduring

visual form" (Trudgill 1975:20), and are rarely meant to be read as literature.

Dramatic discourse, once slighted in linguistic stylistics, has become one of its favourite subjects of investigation (further to poetry and fiction) since the beginning of the 80's. To put in a nutshell the implications derived from the various approaches afore-mentioned for the study of film dialogue, we arrive at the following points of convergence.

1. Dramatic discourse has great potential value in accepting and testifying discourse analysis⁶ as a more reliable resource of techniques for analyzing all types of conversational interaction. While, in the course of discourse analysis of theatrical data, most studies make explicit the divergence of language features between drama dialogue and natural conversation, they are nevertheless mainly concerned with uncovering the conversational routines, structures and strategies in drama text to shed light on the study of the latter. By providing answers as to how discourse analysis of dramatic literature can aid interpretative description of conversation in general, these studies raise

awareness of discourse patterns in everyday interaction and open up a new testing ground for the discourse analysis theories themselves.

2. On the other hand, the integration of discourse analysis and dramatic dialogue implies that, all types of conversational discourse, film dialogue included, are instances of real use of language in real contexts and therefore, their nature and meanings not explained through the more traditional grammatical and semiotic analyses can be uncovered by the techniques in discourse analysis. Take for example, even the 'para-linguistic' interpretation of theatricality based on the concept of a shared connoted semiosis⁷ does not seem to satisfy a full answer to the phenomenon of high frequency of personal and other deictic elements used in drama dialogue to signal speakers' attitudes and social differences in power and solidarity.

3. The Prague School notion 'foregrounding' which applies particularly to poetic language has been highlighted in drama discourse analysis to mark the deviations from established conversational patterns, especially in turning-taking and speech act analysis. It is found

that, compared with natural communication, turn-taking patterns and speech act sequences in drama tend to be clearer and more indicative of topic flow and power relations of interlocutors.

4. Another analytical technique commonly employed in studying dramatic dialogue is conversational implicature. It is generally agreed that, of the four maxims of the cooperative principle, the relevance rule is more important to drama than the others. Further to Gricean pragmatics, politeness phenomena theory has become an equally influential instrument for the analysis of drama talk since the 90s.

5. Constructed dialogue in a drama represents "a communication situation within a communication situation" (Widdowson 1975:50) and thus involves two levels of discourse. It is found that this 'double nature' accounts for the internal structure of drama dialogue in terms of its information patterning and interactional implicativeness (see 2.1.3.1 for more discussion on this point).

6. One of the consequences of this 'two-tier' discourse can be seen in the characters' use of

spoken language involving constant reference to the assumptions otherwise unsaid by speakers in everyday communication. This 'redundant' information is directed to the overhearing third party for the purpose of supplementing shared knowledge between the character (playwright) and the audience, who "is given the information it needs covertly, so the fiction can be sustained that it has indeed entered into a world not its own." (requoted from Elam 1980:149) Another special usage with respect to assumptions in dramatic dialogue is that sometimes the presuppositions held by the characters are markedly different from those people normally hold so that the talk can lead to humorous effect or an absurdist interpretation.

7. Since a play is written for performance, the dialogue is not qualified as sociolinguistic research data until it is spoken on stage and transcribed verbatim et literatim. It takes a full cycle from page to stage and back to page for any dramatic dialogue to establish the authenticity of being a genre of spoken language, one of the reasons being that written words to be 'acted out' are subject to speakers' idiosyncratic ways of interpreting and

expressing the meaning by means of intonation and non-verbal language. So far, discourse analysis of drama texts conducted in conjunction with *performance* has been a new area yet to be explored, particularly with regard to these queries: how does dialogue interact with prosody and the visual? In what aspects and capacity can the composition of the dialogue be visualized to reflect the relationship between text and performance? To what extent are the factors that affect the quality of the final production determined by the dialogue text written for performance? These questions are central to the study of spoken language used in dramatic settings.

Despite the medium differences, film dialogue identifies with drama dialogue in most of the other major respects. By nature, they are both of the same spoken language genre in terms of bearing the most intrinsically dramatic functions as well as distinct linguistic features peculiar to dramatic communication. Basically, what has been reviewed above on the lines of discourse analysis of drama is immediately applicable to the study of film dialogue.

2.1.3 Sociolinguistic Interpretations

Film dialogue is a hybrid of both dramatic and media discourse. It should be viewed from both perspectives because film, like drama, is based on a story and develops characterization and mood; but, on the other hand, the dialogue recorded in the screenplay⁸ from the soundtrack of a finished film is only a multimedia component that cannot completely communicate in its own terms. However, as the object of dubbing or subtitling, film dialogue can be attuned to the self-contained nature of any other literary forms of dramatic language and read as a text from the translation point of view, irrespective of the fact that film as a whole has its own vocabulary, its own syntax, its own way of handling information, and the way of a screen drama is not at all the way of a theatrical play.

2.1.3.1 Form and Function

The idea of film dialogue being a type of dramatic discourse can find further evidence in Widdowson (1975) and Short (1989). Widdowson (id.:pp.50-70) argues that in literary discourse, instead of having a sender addressing a message directly to a receiver, there is an embedded communication

situation. Short (1989) argues that drama text conveys implied meanings which traditional stylistic analysis has failed to account for and offers a discourse-oriented approach to the study of drama (without having to see it performed). The four major topics he concentrates on in his pragmatics-based discourse analysis are: (1) speech acts; (2) presuppositions; (3) the co-operative principle in conversation; (4) terms of address. By providing numerous illustrations and a more extended analysis of a drama sketch, he has demonstrated how these discourse models can usefully lead to a deeper understanding of a dramatic text. On general discourse relations, drama is viewed as a communicative event in which the addresser sends a message to the addressee; but, unlike natural conversation, not even the situation of eavesdropping, Short points out, "... it is arranged to be overheard on purpose" (p.149).

Coulthard (1992) also underscores this double nature of drama and the resultant 'tact' involved in the characters' speech:

...truly 'authentic' conversation would be impossible on the stage: the real addressee of any stage utterance is in fact the overhearer, the audience. Thus, there has arisen the dramatic convention of over-

explicitness, which allows characters to break the quantity maxim and to say to each other things they already 'know', and even things that are strictly irrelevant, in order to transmit economically to the audience essential information. (p.249)

This notion about the marked features of drama dialogue at the character level, which is meant to become messages at the level of discourse between the author and audience/reader, is highly suggestive for film dialogue analysis, as it shares the basic characteristics of constructed spoken discourse with drama dialogue and there are also two dimensions in the system of communication between film and audience and between participants within the film as shown in Figure 1.

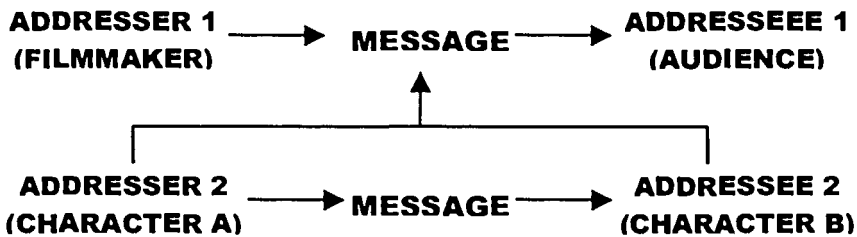

Figure 1

An adapted schema of the dual-level relation in film discourse from Short (1989)

The speaker-hearer-audience discourse relation can be identified in any play or dramatised talk; but with film the communication between addresser and audience is strictly of a one-way system --- the

latter acts only in an evaluative way and there is no element of interaction in the course of the performance. This important difference of film as a once-for-all product of drama contributes to the fact that film in its conceptualized sense means to create an illusion of a faithful record of what is happening in life, so the human speech in it must sound minimally dramatic and as natural as if it is not relied on to tell the story.

As a matter of fact, film is first and foremost visual, as the nature of the medium has determined its unique ways of delivering. Hence what Short (op. cit.) emphatically argues for and demonstrates about analysing drama discourse by concentrating on text-supplied information only (ignoring the actual performance) to achieve maximally the perceptual potential of the meanings, is unlikely to function in film dialogue analysis, not even able to lead to an actable drama translation which is also intertwined with allusive visual signs.

The literary writer always works within the framework of the detached communication situation and is required to work the language into patterns, because literary discourse is dissociated from the immediate social context and independent of normal

interaction. Thus, "if the patterns of literary discourse were only conventional realisations of those of the language system the discourse would lose its independence and detachment and, in consequence, its literary character". (Widdowson id.:62) With reference to the linguistic form of literary works, Stubbs (1980:109) agrees that it is a peculiarity of literary discourse that the language is patterned so as to reflect a reality other than that which is communicable by the language code itself, i.e., "the style of the language used has its own value, and the author may use stylistic features to convey his message". This point also holds for film discourse interaction as a self-contained whole, even though it is a kind of language true to life.

Another peculiarity of literary discourse pointed out by Widdowson (id.:pp.63ff) concerns its mode of communication, which has no analogue in conventional uses of language. He distinguishes between *medium*, the actual physical channel of communication, and *mode*, the character (or the form) and other effects of communication, illustrating that literature reveals an ambiguous combination of spoken and written modes: the medium used in literature is mostly that of writing, 'but

the mode of communicating is not definitely spoken or written in a conventional sense but a blend of both'. (p.64) A typical example of the paradox is the kind of language that is written down for no other reason than to be spoken, i.e., read aloud from a script. (Stubbs; p.112) This point is particularly clear in film dialogue as well as in drama. Crystal & Davy (1969) refer to this phenomenon as *complex medium*; and in dramatic literature the relationship between an author and his characters can be considered as a function of written monologue which is to be expressed in the dialogue form (compare this with Leech & Short's concept of 'the two-level discourse'); hence, *complex participation* also (p.70).

2.1.3.2 Chafe's Four-Quadrant Division

The spoken vs. written modality is the initial distinction in exploring discourse features and has clear implications for stylistics. However, this dichotomy seems to be an ambiguous one, since intermediate cases between spoken and written language are numerous and 'all combinations of written and spoken are possible. (loc cit.) The complications of the outcome arranged as to the purpose of the discourse and its constraints, suggest that the whole range of varieties should be

accepted as a continuum of discourse rather than a clear-cut division. That also explains why sociolinguists (Ochs 1979; Lakoff 1979, 1981, 1994; Chafe 1979, 1982; Dijk 1985; Tannen 1980, 1982, 1989; to name but a few) are concerned with the growing need for a systematic classification of discourse type and new ways of distinguishing them, derived from the spoken/written division.

Chafe (1982), in an article on differences in syntactic and other linguistic structures between informal spoken and formal written discourse produced by the same individuals, finds that written samples are more *integrated* whereas the spoken are more *fragmented*, and that written samples are more *detached* whereas the spoken more *involved*. These four features' --- integration, involvement, fragmentation, and detachment --- need not be associated with writing and speaking; they form the poles of two intersecting continua on which various type of discourse can be located.

Chafe puts the most distant styles - the prototypical sample of speech and the prototypical sample of writing - in the highly-fragmented-and-involved area and highly-integrated-and-detached area respectively. In the same vein as Chafe's

division, Tannen (1982) suggests that imaginative writing combines both the involvement factor of spoken language and the integration of writing and, therefore, it is placed in the upper right quadrant of Chafe's co-ordinate axis (see Figure 2).

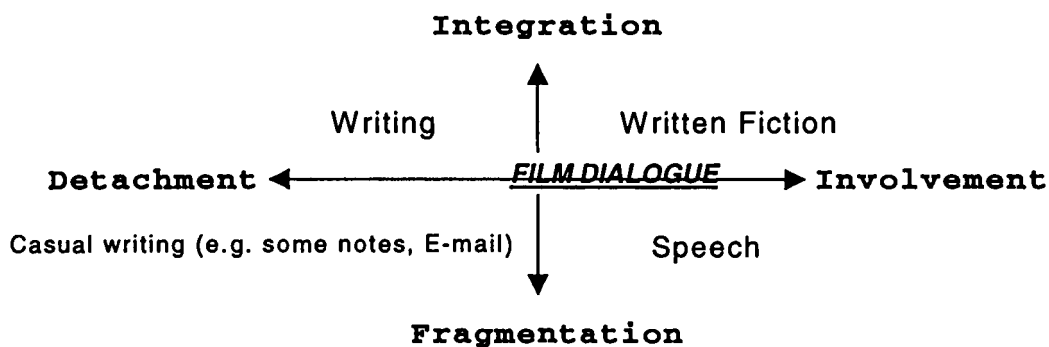

Figure 2

**Schematic Representation of Features of Spoken and Written Language
(adapted from Chafe 1982; Tannen 1982)**

Film dialogue as "deceptive duplication" of real speech conforms to most of the description of *involvement*, as it does to some of the characteristics that typify the *fragmented*, 'spurt-like' nature of speech.

The devices used to achieve *integration* permit the incorporation of more ideas into sense units. Although they are commonly exhibited by formal written English, it is suggested that such integration is formed by the greater amount of planning time available in writing than that for

spontaneous speaking. In general, film dialogue is carefully planned and the grammar used in film dialogue is basically that of the standard variety unless, for example, necessity of true portrayal of a low-variety parole is justified for dramatic purposes. In most cases, the linguistic performance of the main characters in film tends to be idealised; at least, ungrammatical speech comes in to stereotype a character only when some special effect is called for. So, it is not uncommon to find integration features in film dialogue.

Detachment, explained by Chafe, refers to the result of the detachment from the audience, i.e., the situation that the writer or his readers are displaced in time and space -- the writer is therefore "more concerned with producing something that will be consistent and defensible when read by different people at different times in different places, something that will stand the test of time." (p.45) Film dialogue also possesses some detached quality of written language, that of precision, for example.

It is not altogether satisfying to plot an exact position of film dialogue in Chafe's grid; rather, it should be seen as an area, instead of a point,

that mixes each of the four features to varying degrees and that is more to the 'speech' side. In other words, any one of the four quadrants between the two poles of the two different continua is not in itself sufficient to place a discourse type that covers a range of features in both continua. Furthermore, classification of discourse types needs to include and compare form and function together, because types of discourse differ in purpose as well as surface configuration. In this light, we might as well regard *integration-fragmentation* as the surface form of linguistic structure, and *involvement-detachment* as a deeper dimension, reflecting the writer's or speaker's attitude toward the audience. Since they operate on different levels, these two continua are not mutually exclusive. So, we can only say that film dialogue combines features more to the integration side with features more in the direction of involvement¹⁰.

2.1.3.3 Planned Vs Unplanned Discourse

Though not primarily concerned with spoken vs. written modes, Ochs (1979) suggests discourse be divided into planned and unplanned types, resulting from the 'planning time' that goes into a text. She cites four types of discourse: unplanned spoken,

unplanned written; planned spoken and planned written. But she chose data from only two types for her analysis: unplanned spoken and planned written - similar to the samples used by Chafe (1982), i.e., the informal spoken and formal written narratives. She admits, "We have not ...covered all the relevant contexts for understanding planned and unplanned communication. In particular, we lack material to date on unplanned written discourse and planned spoken discourse" (ibid:55). Nevertheless, her study turns out to be revealing and effective in helping to offer a rational explanation for the functioning of film dialogue.

In her definition, "Planned discourse is discourse that has been thought out and organized (designed) prior to its expression" and "[u]nplanned discourse is discourse that lacks forethought and organizational preparation" (ibid.). Ochs then describes the four features¹¹ characteristic of unplanned discourse:

- A) Reliance on immediate context to express propositions;
- B) Dependence on morphosyntactic structures acquired early in life;
- C) Tendency to repeat and replace lexical items in the expression of a proposition;
- D) Similarity in the form and content of sequentially arranged social acts.

The opposite of these characteristics typifies the other extreme, formal (or planned, in Ochs' terms) written discourse; together they form a continuum along which different types of discourse can be distinguished. It should also be noted, however, that these contrasting features reflect several levels of phenomena: register conventions, stylistic variations, medium, relative planning-time available, and so on. This is significant for a taxonomy of discourse types, which are mostly multi-dimensional.

Ochs is aware of the special genre of literary writing. She (1979:77) points out, "There are cases in which a speaker or writer will intentionally produce discourse that appears unplanned. For example, a novelist trying to recreate a casual situational context will use many of the features...of unplanned discourse..." She then suggests that research is needed to assess the self-conscious expression of unplanned discourse features and, to distinguish this use from truly unplanned discourse.

Like Chafe (1979) and Lakoff (1981), Tannen (1982,1989) also emphasizes the verisimilitude of

written literature (fiction and drama) in comparison with real speech. She observes that although written imaginative literature uses features of spoken language in its dialogues to imitate natural speech is not a new idea, "which features does it use, and to what end" needs to be investigated. In line with this inquiry, much work has been followed up; yet, to date, film dialogue seems to remain unattended to.

2.1.4 Summary

Based on the sociolinguistic approaches to the differentiation of discourse types above-mentioned, especially on Ochs' criteria, the present discussion concludes that film dialogue is identified as an enacted spoken discourse type - planned to be overheard as if unplanned - which distinguishes itself from other types of discourse to a point where it must be seen to comprise a unique genre. From the viewpoints of text typology as well as sociolinguistics, foreign language translation of film dialogue for the cinema and television is therefore a unique type of communicative act, which deserves to be a special subject in Translation Studies.

As noted above, cinematic text has been the Cinderella subject for discourse analysts and film

dialogue translation has so far been lacking in extensive scholarly concern and involvement in its whole system. Having offered a systematic outline of the whole set of questions and hypotheses that are intended to direct film translation studies, Delabastita (1989:213) stresses "the urgent need for further research". His assertion that "phenomena such as translation in mass communication have so far been ignored almost completely" (op. cit.:193) has confirmed the view of other linguists preoccupied with the analysis of varieties of discourse in the monolingual setting, as summed up by van Dijk(1985c:1):

Current results from linguistic discourse analysis are as yet ignored in mass communication research.

And further down he adds(op. cit.:5):

It goes without saying that an adequate analysis of the relations between media texts and [sic] context requires a more systematic approach to media discourse. All levels and dimensions of analysis need to be attended to, from 'surface' properties of presentation, ...in printed discourse, or intonation, paraverbal and nonverbal features in spoken media discourse,... through an analysis of syntactic structures, lexical style or rhetorical devices, to the 'underlying' meanings, connotations or

associations, or the pragmatics of speech acts performed. And such systematic analyses should be made for a large variety of discourse types in the media, not only of news, but also of advertising, film, TV-programs (talk shows, etc.) and so on.

The multi-level and multi-dimensional systematic analyses when applied to film dialogue must draw upon a body of theory incorporating linguistic stylistics, sociolinguistics, the ethnography of communication and pragmatics. Such an integrated discourse analysis is able to make clear the correlations between discourse and filmic image, between cinematic text, subtext and context, and between the study of film dialogue and its translation, which is more than the traditional content analysis, semiotics, or even the pure text linguistics, can manage successfully.

The situation concerning the study of film dialogue here, in relation to that of its translation mentioned earlier, gives hints on two accounts: first, the intricacies of the film medium and the subordinate role of film dialogue have misleadingly made the study of it a daunting business for many and an unworthy endeavour for most; second, the lack of scholarly attention given to the film

translation theory can be related directly to the need of research into film dialogue.

The question now seems to be not so much whether the necessity of a concentrated study in a theoretical framework of discourse analysis has been fully justified for either film dialogue or, more obviously, its translation, as whether (and how) discourse analysis of a text genre in a monolingual setting necessarily optimizes the effectiveness of its translation, and vice versa. This leads to examining existing theories relevant to film dialogue translation.

PART TWO: Survey of the Field of Translation Studies

2.2 General Review

Translation studies (TS) have become a separate discipline over the past decade. There are a great variety of competing schools of translation theories. Different perspectives on translation relate to one another. Each of them represents a particular point of view, but there are also significant interdependencies. What I attempt to do in this section is to render a selective account of some influential translation models which are potentially useful for building up a film

translation theory. They are broadly identified as four streams of approaches derived from or inspired by the respective underlying theories of sociolinguistics, the ethnography of communication, text linguistics and pragmatics.

2.2.1 Sociolinguistic approach to translation

Translation has been viewed as a complex act of communication (Nida 1964), "an interlingual and intercultural communicative act" (House & Blum-Kulka 1986 *passim*) and "a communicative process which takes place within a social context" (Hatim & Mason 1990). The confirmed stress on the socio-cultural meaning of a translation act has permeated many developing areas of TS: its nature, central issues, components, scope and methodology. The noticeable trend in the field of TS since the mid-80s has been the insistence on conducting the studies in an interdisciplinary perspective embracing work in linguistics, literary stylistics, philosophy, anthropology and, particularly, cross-cultural discourse analysis.

House & Blum-Kulka (1986) show how explorations in contrastive discourse analysis can contribute to a better understanding of a text in translation. Weizman (*op. cit.*:115-125) examines the notion of interlingual discourse analysis in view of two

types of functions in actual texts, textual functions and meta-textual functions. This is in agreement with van den Broeck's advocacy (op. cit.:37-47) of distinguishing different types of discourse on the basis of their respective propositional content plus illocutionary force to perceive and preserve contextual factors in translation. Borrowing the concept of a "global speech act or macro-speech act" (Van Dijk 1977:238) that embodies a predominant function performed by a speech act sequence, he delivers a classification of discourse types in terms of their corresponding types of speech act function, viz., assertive, expressive, directive, commissive and reflective (ritual/ poetic), and argues that "it is the global and local function of the text which functions as its pragmatic macro-structure and thus determines its type" and these "simple as well as complex macro-speech acts will preserve their basic identity when being transferred across linguistic and cultural barriers" (van den Broeck 1986:38-39). Blum-Kulka's own article (op. cit.:17-35) on shifts of cohesion and coherence in literary text translation (fiction and drama) explicates that translation is an act of communication so that "considerations of both the process and the product of the communicative act necessarily relate to at

least the linguistic, discoursal and social system holding for the two languages and cultures involved." His analytical approach has been derived from two basic assumptions common to the other function-oriented discussions above: 1) that translation works on texts which need to be processed within the framework of discourse analysis; 2) that translation is an act of communication and so its processes, products and effects need to be studied within the methodological framework of studies in communication.

These three components of translation as a communicative task can be examined through the three corresponding activities set up by the translation criticism model proposed by Reiss (1971) and elaborated by Newmark (1981), viz., text analysis, text comparison and translation evaluation, which are in keeping with the revised fundamental procedures of translating - analysis, transfer, restructuring and testing - as developed by Nida & Taber (1974) from the earlier version of the 3-step translation procedures (Nida 1964:241-45).

Nida(1986) points out the inadequacies of three commonly used approaches to translation, viz., the

philological approach, the linguistic approach as illustrated in the 60s and the communication-theory-based approach as developed in the 70s, by stating that their limited perspective can be expanded by seeing translation as an interlingual communication "in its broadest possible orientation, namely, socio-semiotic, with special focus upon the specifically sociolinguistic factors which highlight the distinctive events of communication, the relations between participants occupying quite different roles, the structure of distinctive language-culture communities, and the crucial importance of the interpersonal functions of language." Then he asserts with good reasoning:

At the same time, this approach to translation can make significant contributions to the study of sociolinguistics. In the first place, the very diversity of languages and cultures in the source and receptor communities highlights certain sociolinguistic elements which might very well be overlooked in a strictly monolingual context. In the second place, translated texts reflect a wider range of interpersonal relations than do untranslated texts,.....

This sociolinguistic approach to translation has highlighted the emphasis on interpersonal relations involved in interlingual communication, especially

translating between diverse languages and cultural traditions. Nida's new concept of translation process, shifting from receptor-oriented focus (Nida 1964) to a full-dimensional point of view, emphasizes the validity and appropriateness of the principles laid down by the ethnography of communication regarding the crucial role of the interpersonal function. He defines four different interpersonal relations: "(1) the relation of different participants in the dialogue of a text; (2) the relation of the writer of the text to the persons involved; (3) the relation of the translator to the persons in the text; and (4) the relation of the translator to the receptors of a translation as the so-called 'target audience.'" (Nida 1986:474). The ways these relations are marked, as summarized by him, are especially revealing with regard to general categories of film dialogue: (1) one speaks about oneself (e.g. information or inner feelings directed to the overhearing audience usually by verbalizing shared knowledge between participants in the dialogue); (2) one addresses other people (e.g. argument, warning, questioning, commenting); (3) one talks about others (e.g. joking, gossiping).

In brief, the sociolinguistic approach (as opposed to the descriptive translation theory of

traditional linguistics as advanced by Catford 1965) has formed a substantial part of TS, and represents one of the most influential models of translation. The theoretical orientation of film translation studies should, therefore, be essentially sociolinguistic in its view of cinematic text. In Nida's words, "...any theory of translating must be essentially sociolinguistic in its view of language." (ibid.:472). And any theory of translation in film must help analyse, transfer and compare, not just two languages but two cultures.

2.2.2 The Ethnography of Communication and Its Implication for Translation

Founded and developed by Hymes and others (See Hymes 1972,1986, Duranti 1985, Saville-Troike 1989, Malcolm 1991), the ethnography of communication has shown itself to be of widespread influence and has had growing impact on contemporary discourse analysis. Its primary focus is on the speech behaviours represented in different societies and cultures and its basic emphasis is on the description of speech events contextualized within culture-specific communication systems. One powerful concept associated with the ethnography of communication is Hymes' depiction of the

communicative economy (Hymes 1962, 1986; Malcolm ibid.), in which systematic relations may be plotted among 16 components of speech events (in Hymes' 1972 SPEAKING model), including ends (purposes or goals), setting (spatio-temporal environment), participants, act sequence (message form and content, both verbal and non-verbal), channels, forms of speech (register, varieties etc.), keys (manner or tone of saying something), the underlying rules and norms of interaction, and genres (e.g., jokes, puns, gossip, verbal duelling, story-telling, etc.). This model allows a comprehensive top-down perspective on a communicative event. Such an all-embracing description of not just structural but also non-linguistic features of the language of verbal interaction makes possible a greater understanding of the bearing of socio-cultural context on all dimensions of discourse.

These "contextual variations" (van den Broeck 1986:39) give the translator "more refined instruments for analyzing different types of discourse" and "also offer a more reliable basis for understanding and discriminating particular cases of translation" (ibid.:46). In creating a comprehensive text typology to "recognize a text as

a sample of a particular form which is itself a token of a particular type" (Bell 1991:206) for text-processing in translation, SPEAKING is used as a problem-solving tool for identifying all the listed variables involved in the particular discourse genre being translated into a TL equivalent (ibid.:212).

In the form of highly realistic-sounding dialogue, no other genre of dramatic discourse can provide such a rich source of data, validly representing culture-specific speech acts and speech events, as film. Translation makes the meaning and function of the indigenously patterned signs in the film more identifiable as well as unavoidable. Film translation needs to be handled with a heightened sensitivity to components of a speech event to create parameters for analysing, transposing and evaluating the parallel cinematic texts. On a higher dimension speech events in film can be judged in terms of genre, a conceptual notion defined as "a class of communicative event" (Swales 1990), and "the most stable and solid of communicative event" (Swales 1985, quoted in James 1989). Each genre is bound by a distinctive context and has a schematic structure. In casual talk genres contain more formulaic expressions and

maintain more conversational routines than those identified in film for the simple reason that what is conventional and commonplace is resistant to film's originality and suspense. Nevertheless, genres do appear in film as patterned communicative events typical of a given culture; so translating genres in film should aim at achieving equivalence of genre in the original template as perceived by the SL audience. The viability of genre analysis to be applied to the film translation process needs further investigation. What is noticeable is that "[t]here is clearly much held in common between genre study and the ethnography of communication" (James *ibid.*:32).

Translation studies have been in the forefront of cross-cultural studies of communication for more than a decade. The relevance of the ethnography of communication to translation theory is evident. This is due to the fact that translation must involve comparing and contrasting the conventions of different communication systems in cross-cultural verbal code reception and transmission, whereas the task of the ethnography of communication is "to elucidate these conventions, and to understand the dynamics of their representation and reflection in the constitutive

enactment of situated events." and "it must become comparative in nature, and seek to formulate cross-cultural generalizations and hypotheses which can be further tested in new settings." (Saville-Troike 1989:265,270). As pointed out by Saville-Troike (ibid.), significant applications of this descriptive science are being made in the area of translation, which, like any new study, will also "provide new insights and illuminate new dimensions to guide future research" in the field of the ethnography of communication.

2.2.3 Text Typologies and Translation

One of the key topics of text linguistics is the classification of texts by means of "establishing typological indices" (Hartmann 1981:119) according to their domain-specific stylistic and contextual parameters. As already pointed out in this study, the merging of text typology and translation has been one of the focal subject areas in TS. Attempts in unifying theories on the relation between text typology and translation are persistent and numerous (apart from those pertinent translation works mentioned previously, also Hartmann 1981, House & Blum-kulka 1986, James 1989, Bell 1991 and Hatim & Mason 1997). Most view translation as an intercultural communication

process via text transfer and share the opinion that the problem of the text-types is a particularly significant one in translation because of its intricate interaction with the related discipline(s) from which the text being translated is originated. From the text linguistics standpoint, "the relationship between individual texts and abstract ideal 'types' of which they are thought to be 'token' realizations" (Bell *ibid.*:227) is regarded as a complex one by itself. The traditional form-function dichotomy of text typologies has not been widely accepted and applied in Translation Studies for lack of a comprehensive and plausible framework for defining, grouping and distinguishing texts. The central issue that has remained to be addressed in a cross-cultural perspective is how and to what extent translations are affected by text types.

In recent years the possible application of text typologies to translation both as process and as product has become one of the keenest concerns of many translation scholars. The text typological approach to syllabus design in translating (Hatim 1984) is reconfirmed and developed in Hatim & Mason (1997) where the "basic hypothesis underlying [their] proposed curriculum design is one which

relates the notion of text type to the actual process of translation and to the translator at work" (p. 181). This extended view typifies a shift of emphasis intended by the studies in this area from examining text types to gain insight into translation as product to the process of translating and from what the translator should be informed of the combinatory possibilities of typological components to how the translator can actually tackle different text types in daily practice. More importantly, it represents a more pragmatic approach to comparing the similarities and differences in formal features and communicative functions of a text type between the original and the translation. By acknowledging the advantages of classifying and describing the text types for the purpose of understanding the process of translation to achieve an all-dimensional translation equivalent effect as the first phase, this trend of research focuses on the other area of investigation which seeks satisfactory answers to such questions as: To what extent and in what areas are text types identical across languages and cultures? What level of translatability can be attained in typological reconstruction from the original to the translated text and what degree of

skewness within the norm of a targeted text type is allowed for a translation?

TS has gained considerable momentum in the past decade as it is growing into a full-fledged discipline and extending its sphere to virtually all types of cross-cultural communication in the form of text. The continuing influence of text linguistics on the former will become more weighted with the projection of its text typology theories merging into a new context of meaning. The inclusion of more and more varieties of text types among subjects for specialized studies in the field of translation calls forth higher demand on quality assurance and quality management by the establishment of professional standards and the achievement of international standardization. Audio-visual translation is one of the areas that can benefit immediately from the interlocking of text typology and translation which requires translators in the field to become competent professionals with raised consciousness and updated knowledge of text types.

2.2.4 Pragmatics-informed Approaches

Translation studies has been cross-fertilized by new ideas in other fields of study in recent years. No longer does it favour the manoeuvres of treating

language problems from a solely linguistic viewpoint; this fast-unfolding field seeks to enrich its theories by accommodating principles and methodologies of other applied disciplines, pragmatics being one of the most effective. Such a shift in thinking is a major breakthrough in translation studies as pragmatic factors contribute directly to creating a framework for establishing the closest possible correspondence between languages at the level of the semantic unit - the focal point of the unceasing debate on the definition of translation equivalence (TE).

Acceptance of pragmatic rationales in translation theory-building has resulted in the emergence of a series of new competing models of translation since the early 90s (e.g. Malmkjaer 1993, Tabakowska 1993, Snell-Hornby 1994). Among them the variational model (see e.g., Hewson and Martin 1991) has brought deeper insight into the translation reality. It has taken into account contextual and extra-textual variables in an all-inclusive manner for defining socio-cultural norms to which all texts to be translated should correspond. This text-in-context approach is one step further from the textual approach to translation (as described by Neubert & Shreve

1992)¹² which argues for an integrated theory based on pragmatic considerations but addresses the whole question of context only initially. The main thrust of this latter model lies in the authors' pragmatically-motivated research methodology, which complies with their overall aim of developing a more empirical approach to translation. In a sense, both models represent the corollary of inclusion of pragmatic factors in TS and deserve a closer look.

2.2.4.1 The Textual Approach

This approach views translation essentially as text. By making text act as a unifying concept in the discipline as well as the primary object of research, it attempts to incorporate the multiple divisions of thinking in TS into an analytic framework which can be used in the empirical study of translation and in translation practice. The rationales behind this approach as summarized in Neubert & Shreve (ibid.) are consistently text- and practice-driven.

Firstly, "[a]ny theory of translation has to account for the textuality of translations" because "a translation is always a text" and "a textual process". A theory of translation is basically a

theory of texts. (p. 147) Secondly, "[a] text-based theory of translation should be grounded in and verified by the empirical observation and analysis of real text and real translations". In other words, it should be practice-oriented, because it sets out to "explain and describe translation, but it also aims to improve translation".(p.148) And thirdly, "only the textual approach is completely tied to practice" (p.147), because it treats a translation as a text first and foremost and focuses on the textual process so that what the theorists and the translator in practice eventually commit themselves to is optimizing "the end result of the process" (ibid.) that is a text as translation product. Therefore, the "conceptual validity and practical utility of [this] approach can only be tested by the observation of translation practice."(ibid.)

The theory that translation is a textual process and that a translation is always a text has implications for other models that "contribute to our understanding of translation as a linguistic, psychological, computational, critical, or social phenomenon" (Neubert & Shreve ibid.). On the one hand, based on the assumption that, with little exception, these other models have dealt either

with translation as a process or the finished translation as a product, the textual approach, by looking at both parts of translation, intends to combine process and product and use it as a global strategy to conciliate this traditional controversy in TS. In an effort to do so, Neubert & Shreve set forth a list of research parameters to divide up the complex subject for empirical translation studies, and point out that a failure to clarify these parameters will increase the potential for misunderstanding.

On the other hand, it also has implications for the old translation concept of translatability which is another major issue among different schools of translation theories. According to the textual approach, translatability depends only on textual factors. The assumption underlying this vision is that "it is within the text that structured interactions and interactional structures coincide" and "[t]ranslatability, like communicative equivalence, is a relation between L1 and L2 texts", so "[it] relies on the potential for textualization and ... for communication." and is "only possible within the bounds of their prototypical textuality" (Neubert & Shreve *ibid.*).

A significant contribution this model makes to the process-product debate is that it abolishes the traditional distinction between 'pragmatic' and 'literary' texts where the former (e.g. research papers, school-leaving certificates, regulations, etc.) is regarded as not 'creative'. It argues that translations are "text-induced text productions" and translators dealing with any text types are engaged in the same process of facilitating "the textuality of the target text by mediating the two textual systems" involved (ibid.:25).

To sum up, the overall aim of the textual approach is to unify translation studies under the banner of textuality and translation as text. The clear message it has delivered is that there is textual meaning above the sentence level; to explain adequately these "suprasentential textual factors" (ibid.:p.23), a translation model must have recourse to a systematic study of "the various uses of language by speakers and writers in particular communicative situations" (ibid.), i.e., pragmatics, which is better equipped than the "linguistic systems of the source and target" (ibid.) texts to account for the motivation of extra-linguistic changes made to produce a good translation.

2.2.4.2 The Variational Approach

The variational approach (VA) as initiated and detailed in Hewson & Martin (1991), is named as such because it is concerned with establishing the place of socio-cultural parameters and norms in defining the contextual and extra-textual variables involved in each translation situation. In their words, "it is based on a double movement - first generating a wide set of correlated paraphrastic possibilities in two or more languages, then going through a number of selecting procedures in order to choose a final Target Text" (ibid.:vi). These two complementary stages of generation and selection govern the process of translation from a potential target text to its finished form. VA is a more dynamic approach to translation than the textual approach in that concepts of translation and translation equivalence are essentially redefined and pragmatic factors are brought into full play to invoke a new way of thinking about translational variability.

The two tiers of the variational model examine two main areas of research respectively, the generation of homologues and the different parameters determining the selection procedure. Operating on

the threshold of the selection (and elimination) procedures of the model, Cultural Equation, a new but somewhat abstract concept introduced by Hewson & Martin, is set up to examine the language-culture relationships with respect to "what translation necessarily includes in the selection process" (ibid.:111) which culminates in a wide range of well-described socio-cultural and non-linguistic parameters which contribute to guiding the translator to make the choice of the final target text.

The key note here is that of specifying socio-cultural norms for all texts to be translated to match, i.e., "no text and no translation can exist without explicit socio-cultural determinations" (ibid.:53). It is originative in translation to maintain that every factor "has to be assessed in terms of its insertion within the target language situational and discursive norms" (ibid.) - a seminal point which dispels the myth that some norms are more constraining than others and translators of some text types that correspond to the former norms are accordingly considered to be more creative than those of other types. Here, in agreement with the textual approach, VA drives home the same argument that translators of pragmatic

texts (or "normalized texts" as so called by Hewson & Martin) are just as creative as translators of literary texts and that the process of translation is the same irrespective of text types.

The definition of 'equivalence' is discussed in Hewson & Martin (ibid.) throughout, which includes instances of "confusing contextually irrelevant distinctions for semantic equivalence" (p.65). In redefining equivalence, the term is replaced with a combination of 'homologon' plus 'norms', or the combination of the two phases of VA. Their arguments for eliminating the term are tied up with their interpretation of "meaning" in translation, which holds texts in contexts. In their view, "no transfer or equivalence of meaning can be achieved across languages" because "[t]here can only be homologies between paraphrastic sets" (p.47).

This redefinition of meaning is apparently crucial for translation since "there is no difference in kind between paraphrastic and meta-linguistic reformulations, only difference in logical constraint and the paraphraser's degree and type of competence" (p.46). In virtual fact, the translator's competence is the decisive factor, which in turn calls for redefinition. Three types

of competence are then distinguished: acquired linguistic competence, dissimilative competence and transferred competence, together acting as a specific capacity that every translator possesses "to a greater or lesser degree and which fundamentally influences to the nature of his productions" (p.52).

Another significant distinction made is the two 'actors' who are both indispensable in fulfilling a translation task - Translation Initiator (TI) and Translation Operator (TO). The former is defined as "the driving force behind the act of Translation" (ibid.: 113), which, in most cases, identifies as someone who motivates the need to convert a ST into a TT and gives the translation order to the TO, i.e., the translator. The concept of TI "is totally absent from Translation theory" (ibid.), but "the socio-cultural identity of the TI is of prime importance" (ibid.:114), since in reality it has "a fundamental influence on the Translation operation" (ibid.:113), for example, the instructions the TI gives the TO "can be determining in itself if it is of a restricted or specific nature" (ibid.).

Previous translation studies take it for granted that translation only depends on the performance of the translator who is idealized as the operator working in the best possible conditions free from external constraints. VA for the first time underscores the influence of the TI on the translator's working circumstances and decision-making that directly affect the outcome of translation. Instead of isolating the translator from the socio-cultural and economic realities in which he carries out a translation task, it takes into consideration his clients' wishes, needs and the demands of the workplace as well as other pragmatic factors which give rise to his particular translating context. Hewson & Martin (ibid.: Chapters 9 & 10) gives a working demonstration of the model using concrete examples to illustrate the ways in which pragmatic factors influence the decision of the translators. Applications of VA to translation, as they demonstrate, concentrate on the effect of extra-linguistic factors and the corresponding translation strategies in relation to various text types including dramatic dialogue¹³.

All in all, the theories brought forth by the variational approach to translation dwell in a composite system, which are articulated through a

translation model and supported by its applications to the translation of diverse text types. The theoretical justification for the necessity of an overall redefinition of vital concepts in translation is substantial and delivered in a comprehensive manner in Hewson & Martin's original work. While providing translation theorists and practitioners with a fresh alternative view of translation as reality, it heightens their awareness of the truism that translation can not be objectively conceived unless examined from a new perspective with pragmatic mechanisms playing a telescopic and microscopic role in analysing the socio-cultural and economic parameters and norms that define the limits for the translator to make choices in producing the target text. In so doing, it attempts to resolve the conflict between some major schools of thought on the key issues in translation theory by "conciliating and synthesizing the merits of these contradictory opinions and regrouping them in a wider perspective" (ibid.:39), which is variational to the traditional points of view.

2.2.4.3 Summary

Both the textual approach and variational approach attempt to build up an integrated translation model

highly-evolved in theory and applicable in practice. To a large extent, they are successful in revealing the far-reaching significance and potentialities of taking pragmatics as a guide in redefining and rethinking translation - a timely contribution to advancing the theory of TS in recent years. They represents a new trend that adopts a realistic and all-inclusive attitude towards contextualizing the internal and external factors in translation that cause possible problems to the translator and affect the product quality.

Central to this pragmatics-informed approach is the provision of a potential alternative to the many previous answers to the question of what is the 'best' equivalence in translation. The answer has been syncretized in Ruuskanen 1996 under the watchword of the "Pragmatic Other", a "pragmatic construct" (p. 892) referring to the translator initiator and/or translation consumer to whom the translator is committed and for whom a translation is created. The definition as concluded by her is an unequivocal message:

... it has become apparent that translators create a Pragmatic Other to whom they address their translation. ... Thus "equivalence" becomes dependent on time and the needs of the Pragmatic Other. This leads

further to a variable definition of equivalence, a definition which will be different for each text each time it is translated. It follows that the best translation will be that which best meets the needs of the Pragmatic Other. (p.893)

The validity of this general definition of translation equivalence is yet to be further testified. Nevertheless, the pragmatic principles as articulated above are dynamic guidelines which are conducive to a sound working definition of TE of any specific text of any type, film dialogue translation being no exception. Because of its special language-culture relationships and unique multiple constraints of the translator's context, film dialogue translation needs to be more pragmatic in orientation, both to the translation process and the quality assessment criteria. The relevance of the pragmatics-informed approach to this type of translation is indubitable.

2.3 Drama Translation

Of all areas in TS, research in drama translation is of the closest relevance to film dialogue translation (especially dubbing), because these two types of translation of dramatic spoken discourse

have many affinities with each other in terms of translation principles and genre performability.

2.3.1 Introduction

Translation of stage plays has long been regarded as a subject that requires special considerations and expertise mainly because the primary purpose of translating a play is to have it performed, which challenges the translator to an "impossible" task (Wellwarth 1981:145; Duff 1989:259; Bassnett 1991:120; Edney 1996:229) of delivering the words and their hidden culturally-specific meanings in another language not only with accuracy and the original beauty but also easy intelligibility. The translator therefore needs to work closely with the producer and always bear in mind the actability of the dialogue lines and the potential audience of a different culture.

Earlier studies (1950 -1980) in drama translation along this line are represented by the translation theories and practices of such influential European playwrights and drama translators as Una Ellis-Fermor, George Mouning, Michael Meyer and Norbert Hofmann. Identifying drama translation as a science was first brought up in *Page to Stage: Theatre as Translation* (Zuber 1984) after the

publication of another book edited by Zuber (1980a) *The Languages of Theatre: Problems in the Translation and Transposition of Drama*, which is the first comprehensive work in English that focuses on drama translation including verbal, non-verbal and cultural aspects as well as staging problems. Based on the main ideas of these two books, her later article (Zuber 1988) takes a further close-in view of drama translation in an attempt of establish it as a subsection of literary translation science. Wellwarth (ibid.) highlights *speakability* among other factors involved in translating drama texts. Alan McConnell-Duff describes in detail the special difficulties facing the translator of stage plays in his work on recurrent problems of translation into English (Duff 1981) and his paper on cultural and linguistic constraints upon drama translation (Duff 1989).

Despite these and many other efforts (Hwang 1981, Akerholt 1985, Hewson and Martin 1991, Mateo 1995, Johnston 1996) to study drama translation as a special type of translation, it has remained "one of the most neglected areas" (Bassnett id.:134) in TS. "Whether linguistically oriented or not, the study of translated dramatic literature has been

treated extremely superficially by translation studies" (Lefevere 1980:160) and, still, "[t]here is a need for a comprehensive study of theatre translation with a view to establishing a theory" (Bassnett *ibid.*). In this section, the main issues addressed by the more recent contributors to the existing literature on drama translation (mostly aforementioned) will be reviewed. Among all others, Zuber (1980-1988) deserves a special mention.

2.3.2 Zuber's Contribution to Drama Translation

The pioneering effort of leading towards a typology of drama translation science reflected in Zuber's works (*ibid.*) includes: types of translation and classifications of drama translation; the process of translating a dramatic text --- the first stage covered by six steps¹⁴ --- and transposing the translated text into a performable script and on to the stage, including the translation of the non-verbal signs --- the production process in two steps special for drama translation; and directions for future research.

Non-verbal signs in drama translation have been emphasized by Zuber (1980b) and Gostand (1980). Zuber focuses on problems of semiotics, i.e., translating non-verbal signs in drama. She has

made a detailed analysis of the complex system of allusive signs in Tennessee Williams' *A Streetcar Named Desire* and shown how the playwright "gets his message across to the audience not only by means of dramatic action and dialogue but through non-verbal allusive signs of accentuation and association; ..." (p.72). In doing this she relates the original to the German translation's successes and failures in transposing these signs. She makes a distinction of two main versions of a drama: the reading edition and the acting edition. After studying all the various text editions of the original to grasp its full meaning, the translator of the stage "has the difficult task of transferring the whole network of signs", "...not only to translate the dialogue and the stage directions linguistically, but to contemplate whether the visual and acoustic signs can be maintained as they are in the original, and, if they are linked with linguistic signs, ...whether a combined sign would be better replaced by a completely different sign signifying the same idea." (p.73).

Obviously this approach does not quite apply to film dialogue translation since film lacks the spatio-temporal fluidity of drama: the only vehicle for representing film dialogue translation is

verbal signs. However, in principle, film dialogue translation should also be translation of the overall message that various allusive signs combined mean to convey --- through words. "In addition, the emphasis on visual communication peculiar to film and television can be intensified by camera and cutting techniques to give new significance to what is seen...." (Gostand 1980:6). Film, therefore, has an even more complex organization of non-verbal elements to examine; translating cinematic speech without relating to the performance is running the risk of disintegrating the 'movie world', especially in translating tightly-knit linguistic-kinesic behaviours.

Zuber's practical approach to drama translation is basically derived from the semiotics of theatre, dramatic criticism and comparative literature theories. As the five suggested areas for future research indicate, it is still an initial sketch for setting up a 'science' which needs a unified theoretical framework to link and govern the different componential areas of drama translation. Although cross-cultural factors are stressed throughout drama translation from page to stage in these studies, an analytical and evaluative system

informed by sociolinguistic theories seems to be the full answer.

Nevertheless, apart from the contribution to drama-translation-building, the progress in this field has a significant implication for film dialogue translation: firstly, the definition of drama translation as "the translation of the dramatic text from one language and culture into another and as the transposition of the original, translated or adapted text onto the stage." (Zuber 1988:485), mirrors the nature and necessity of film dialogue translation. Secondly, the five areas of research pointed out for further development in drama translation (op. cit.:489) have offered a panoramic view of translation coverage unique to drama: 1) translation and production process as a continued whole; 2) drama translation criticism; 3) research concentration shift from translated drama as the text basis for the stage production to that as a performing art; 4) "the study of a performance of a play in the original language and culture in comparison with that of the same play in the target language and culture." (ibid.) 5) quality assessment and effect interpretation of drama translation performance. These research topics have direct relevance to working towards film dialogue

translation as a discipline, although expansion and modifications are necessary, e.g., the situation for the existing film dialogue translation practices and research appears to be the reverse of that for drama translation in 3).

2.3.3 Text and Performance

More of a performing art, drama is distinct from other literature genres. A drama text is not finished until it has run through the whole communicative process between the playwright and the receptor from page to stage. Translating drama into a foreign language also means working for the stage, but such a medium compels, but does not allow, footnotes in the target language. This extra dimension poses the translator a particular series of problems, which are not found in other types of translation.

Various epithets are used to describe the nature of drama text and drama translation. Sussan Bassnett emphasises that dramatic text "is read as something *incomplete*, rather than as a fully rounded unit. (ibid.:120) and that drama translation is "a performance-oriented translation" as contrasted with "a reader-oriented translation" (id.:131). The same opinion is seen in Hewson and

Martin (1991) when applying their variational model to the field of drama translation: "[a] dramatic text is by nature incomplete" as "[t]he play's text is ... accompanied by 'stage directions'..., but the rest of the text is usually left in various degrees of decontextualization" (p.187).

Duff (1985) takes drama as a particular literary genre, partly because it is "an international art" (p.232). What Bassnett-McGuire (1985:88) perceives as the "paradox" confronting the theatre translator, Duff calls the "dilemma which the translator of drama can never avoid", viz., "... he or she is working from a written text to produce words that are primarily intended to be spoken and heard" and "[y]et at the same time, the text must stand up to the scrutiny of the eye" (Duff 1985:233). Akerholt (1985) holds a similar view that "the quality of a dramatic translation can ultimately only be proven in the theatre" (p.14). Crampton regards drama translation as "a subject of its own, ... because the lines must be speakable ..." (Picken 1989:78). By the same token, Wellwarth (1981) refers to drama translation as "a specialized form of translation" (p.140), whereas

Newman (1994) defines it as "a type of specialized covert translation" (p. 4699).

Link (1980) points out dramatic text, being realized in a different communication system from that of prose fiction, is "incomplete or represents the full play only by implication" (p. 25), and "the complexity of drama and theatre" as "a mixed art" of both literature and a stage production (p.49) determines that translation, adaptation and interpretation of dramatic text as three interdependent strategies are inseparable in the process of drama translation (passim). This phenomenon is aptly explicated by Mateo (1995) in terms of drama texts showing "a double nature as both literary texts and performance scripts" (p.21) and being "a complex of aural, oral, visual, paralinguistic and kinesic signs which cannot be eluded in the [translation] decision-making process" (p.25), and which makes drama translation become "a particularly complex task" (p.23).

Much has been said on the question of whether a drama translation can be stylistically and functionally effective in both forms of published text and stage performance (Link 1980:passim, Ritchie 1984:passim, Bassnett 1991:120-132, Hervey

and Higgins 1992:158, Fang 1992:passim, Mateo 1995:24, Edny 1996:229). The prevailing view has been that it is impossible for the translator to separate text from performance, nor to pursue two different goals to satisfy both the reader and the audience. The central problem facing the translator is "whether to translate the text as a purely literary text, or to try to translate it in its *function* as one element in another, more complex system" (Bassnett 1991:120). Since "the language of theatre ... runs parallel to the extralinguistic situation, and any change in one will provoke a change in the other" (Mateo 1995:22), "[t]he difficulty... consists... in determining the respective values of text ... and performance" (Hewson & Martin 1991:187). Newmark (1988:173) makes it clear that "[w]hilst a great play may be translated for the reading public's enjoyment and for scholarly study as well as for performance on stage, the translator should always assume the latter as his main purpose ...".

Taking it as a whole, the key point that repeatedly presents itself from the existing literature on the nature of dramatic dialogue translation can be briefly summed up in Bassnett's words: "the translator must take into account the

function of the text as an element for and of performance" (id.:132).

2.3.4 Drama Translation Principles and Strategies

To Bassnett, determining the functions of the text to be translated is the central issue of any type of translation. For the theatre translator the key function to achieve is to operate on "the performance aspect of the text and its relationship with an audience" (ibid.). Meyer (1974) regards tautness of expression as "the first principle of play translation", and the re-creation of the SL meaning in syntactically and socially accepted style of TL as "another vital principle" (pp. 44-45). Wellwarth (1981) stresses the importance of "speakability" over "concision" of drama dialogue, but he insists that "the first principle of play translation is style" (p.142). On the other hand, Akerholt (id.) holds the "speakableness" of a dramatic text to be the first consideration, while she immediately adds, "[i]deally, therefore, the translation of a play should make the same impression on the audience as the original work did on its audience" (p.9). These views on capturing the spirit of the words in drama translation are confirmed in Duff (id.) when he concludes, "[t]he

translator, ... must be guided primarily by the overall effect of his delivery: it is not so much the sense that must be preserved as the fluency and the rolling rhetoric" (p.257). On a similar note, Mateo (1995) suggests that the primary goal of drama translation should be to keep the original speech rhythm, which is the common parameter in the three factors that define drama translation, viz., the oral nature of the text, the time factor and the economy of the language of drama (pp.30, 32).

These guidelines involved in drama translation lead to a series of relevant translation strategies. A generally recognized division construes translation in the context of stage drama as of three categories: literal translation, direct translation and free translation. A literal translation keeps to the original dialogue most faithfully in all lexico-syntactic aspects but carries the implication of being unidiomatic, ungrammatical and therefore mostly 'unspeakable', hence it has little relevance to the stage unless the two languages involved in translation have a certain number of grammatical rules in common. A direct translation is understood as an attempt to preserve all aspects of the original in terms of structure, style and tone. This is considered to be the most difficult

of all since it demands the translator's sound bilingual knowledge and communicative competence to best convey the nuances, the allusions and the tone variations of SL, and to find creative ways to compensate for the loss of meaning when it is necessary to interpret the words instead of a direct rendition of the original. A free translation gives more room for creative choices and comes close to adaptation. It allows the translator such freedom as altering the details of the content, applying new emphasis to the lines, and accommodating a different pace and rhythm in TL from that of SL. To a large extent, the translator virtually provides the meaning rather than interpreting the original sense of the words¹⁵.

Bassnett points out that drama translations have often been criticized as being either "too literal and unperformable or as too free and deviant from the original" (id.:123). Duff (id.) holds with the view that "any production of a foreign play is likely to be an amalgam of the literal translation and the free adaptation (p.234). But he believes, "... a translation need not necessarily be free" and "[a] literal translation will often be adequate, provided the translator has tested the language against his ear" (p.256). While conceding

to the basic point that there are no rules for dramatic translation, Wellwarth (id.) finds it necessary to distinguish the *interlinear transliteration*, "the most rudimentary form of translation", from *situational conceptualization*, "the most sophisticated form" and "the only form acceptable for dramatic translation" (p.143). As he explains it,

... what is required is something more than a morphological transformation of words and a point-to-point transference of semantic values. What is required is the re-creation of a situation or cohesive semantic block in the new language in terms of that language's cultural setting. (ibid.)

Obviously, what he means by *conceptualization* is a form of translation which is a far cry from word-for-word translation but does not relinquish the other options on the translation spectrum to the free translation end. Such a theory derived from the 'ideal objective' of drama translation as mentioned earlier is based on his belief that "the translator should always be translating into his own primary cultural/linguistic milieu" (id.:144). This target-culture-oriented approach can also be seen in similar but more balanced remarks in others, for example:

... by making the play attractive to an audience and speakable, one has... to move far from the original. (Zuber 1984:15)

.. translations which adhere too closely to the syntactically and linguistic aspects of the original, ... are not effective on stage. (Lai 1984:149)

A translation which imitated too faithfully the rhythms, pauses, and stresses of the English - not to mention the style and the vocabulary - might easily fail to convey the general intent of the speech,... (Duff id.:255)

... translator must make the characters' expressions compatible with speech patterns, inflections, and idiomatic idiosyncrasies more or less identifiable in keeping with potential audiences. (Hewson & Martin 1991:187)

Despite the differences in the age-old discussion as to how much freedom is allowed in drama translation, the ultimate aim to maintain a rational poise between literal translation and free translation by sticking to the invariability of pragmatic aspects in drama translation has been widely held by most. Translating Hofmann and Mounin, Gutt (1991) reiterates the stand that "[o]ne has to translate its effectiveness on stage first before giving consideration to the

reproduction of its literary or poetic qualities, and if in this conflicts should arise, then priority must be given to the effectiveness on stage." (p.119) Duff (1985), in quoting Una Ellis-Fermor, also takes the same principle as a guide: "[i]f we have to choose between the run of the dialogue and the accurate presentation of one of its component sentences, the interests of the dialogue as a whole must win." (p. 253)

2.3.5 Translating Rhythm in Dramatic Dialogue

Duff (ibid.) further notes that it challenges the drama translator to see how the dialogue is delivered in order to convey what is not in the words into the target language. As expressed by him, "the translator needs to be able to see beyond the words" (p.254), because "[t]he written word is not the final word; the last word is the actor's...", whose speech "will have pauses, inflexions, and changes of rhythm that do not appear on the page" (p.246). The delivery of the speech - "cadence and rhythm, pause, stress, fluency and hesitation" (p.254) - is the key to revealing the "intent of the speech" (id.), the "spirit" (p.256), or "the general tone" (p.257), which is crucial for the translator to capture

before he can mete out the appropriate degree of freedom in drama translation.

Meteo (1995), on the superiority of "how and when it is said" over "what is said" (p.26) in drama translation, argues that "the phonetic characteristics of the sounds in the text" (p.28) as part of the language body are too important cues to be overlooked by the drama translator owing to the oral and aural nature of dramatic text. She duly highlights *rhythm* of the speech among other paralinguistic features: "An important element of drama texts which derives both from their oral nature and from the prominence of the time factor is *rhythm*" that underlies "every line and the strength of spoken language" (p.29). As a matter of fact, the significant role of rhythm is the focus of many studies in the literature on dramatic translation. Newman (ibid.) points out that "[i]t is important for the translator to reproduce the appropriate speech rhythms and recreate the dramatic situation". Vivis (1996) makes it more explicit, "Crucial to a successful translation of drama ... is the attempt to recreate an appropriate rhythm" because "[v]ariations in rhythm alter emphasis, pace and through them, ... meaning" (p.39). His description of rhythm of dramatic

dialogue as "a complex and living organism" and "the energy, the heartbeat, the metabolism of language" (id.) contrasts with that of a translated drama text void of such "genre-making features" (Hervey & Higgins 1992:153-157), what they call "a pale copy of speech" (id.:157).

Bassnett (id.) also puts rhythm first before other listed extralinguistic elements which characterize the dialogue but "may not be immediately apparent from a straightforward reading of the written text in isolation" (p.122). From examining Racine's plays, she discovers "the rhythms contained within the language ... determine patterns of physical gesture of the actor" (p.124), which supports the conclusion that the relationship between the dialogue and the extralinguistic situation is intense and reciprocal (Bassnett-McGuire 1987:121). Attaching importance to sharpening the translator's sensitivity to "rhythm and phonological considerations" (p.153), Lai (1984) discusses the merits and necessity of retaining "the rhythmic patterns" of the drama dialogue through keeping an approximate syllable count at the speech turn level between the English original and Chinese translations (ibid.:150-151). She underlines "the

general aspiration of translators in not making their translation longer than the original" (p.151) and implies that, to some extent, drama translation, at least in that from English to Chinese, should strive to preserve the original sequence of words for the rhythm (*passim*).

As a matter of fact, the correlation between rhythm as a covert code and word order as an overt code in spoken language is such that the rhythm of an utterance in a particular language genre is punctuated by the sequential arrangement of words in *prominent units* (Crystal 1985:248). Therefore, "word order can change a rhythm, and with it the whole accent of a sentence" (Vivis *ibid.*:39). In the case of Beijing Opera¹⁶, an art form that blends singing, dialogue and mime in one show, the relationship between rhythm and word order is even more revealing. Lai (*id.*), in comparing the rhythmic pattern in speech drama translations in Chinese with that of Beijing opera, observes that "the musical element is much more prominent [*sic*] in Chinese opera", where "much of the play is sung to music which is made up of a combination of a ... set of rhythmic patterns" (p.151). These rhythmic patterns that permeate both the singing and the dialogue of Beijing opera are called **yun** in

Chinese, which keeps prominent words in each line in regular beat. In analysing the English translation of the Beijing opera *Phoenix* (*Fu`Huan`Chao`*), Shao (1986) demonstrates that the *yun* in Beijing opera must and can be preserved to the maximum degree in the translation for performance in English¹⁷ by using such means as similar syllable count and word order in each line (p.44). Hwang (1981) on translating the dialogue of Beijing opera for the stage is in favour of the view that the translator must uphold emphasis of the original by so arranging his words that syntactic considerations in the target language, if necessary, can be sacrificed, for the reason that "word order is important in relation to stage movements, sequences of imagery presentation, and dramatic effects in the rendering of Peking operas" (p.60). Much of the findings from the Beijing opera translation practices is significant to drama translation between English and Chinese, as both art forms are stage dramatic performance with dialogue and both are concerned with how to transfer meaning and rhythm faithfully and effectively across the two widely diverse cultures. In fact, the purpose of drama translation of all kinds is "to transpose a text from one language into another in such a way that structurally,

thematically and stylistically, the translation is as close an equivalent as possible to the original" (Akerholt 1985:9).

2.3.6 Drama Translation and Film Dialogue Translation

Drama and opera translation is defined under the heading of "Professional translation" (Picken 1989:75), which covers those types of translation where "language is the vital element and presentation of the message is paramount" (id.:78); whereas translation for TV and cinema film as a type of text for "Extracting information" (id.:82) being its first function, is ranked among "categories of translation in which parity of information is the prime objective of translation" and "keeping the information accurate and complete" a prerequisite (id.:79).

From a different perspective, Hervey & Higgins (1992) point out that, "as a ST, any text is already an object in its own right, and actually belongs to a particular genre of the source culture" (p.135). They regard both "drama performances" and "film sound-tracks" as belonging to oral text-types as distinguished from written

genres and sharing the genre-defining properties all oral genres have in common, i.e., "the fact that they are realized in a vocal medium" (p.136). Three important implications derived from this truism are then spelt out to characterize an oral text in terms of: (1) a "fleeting and unrepeatable" nature; (2) "visual cues" that "form part of the overall text"; and (3) "the appearance of spontaneity" (ibid.). They add that this last implication "goes ... for prepared texts as well" such as "memorized lines in a play or film", which "give the audience a chance to enter into the illusion of spontaneous vocal utterance" (ibid.). With their emphasis, they sum up:

... on every level of textual variable, oral texts must obey the 'rules' of a spoken language first and foremost. It also means that an effective oral text avoids the problems of comprehension arising from informational overloading, ... (ibid.)

Obviously, "in all these respects, what is true for oral STs is true for oral TTs as well" (p.136), as they conclude,

An awareness of these properties of oral texts and genres is a necessary starting-point for discussing the particular types of problem that confront anyone wanting to

translate an oral ST into an oral TT.
(p.137)

On the dimension of "genre-marking and crossover between oral and written genres" (ibid.:Ch.12), drama translation is distinguished from film translation. Four forms of translation are thus identified (Table 1).

FORM of Translation	PROCESS		TYPICAL EXAMPLES
	ST Genre	⇔ TT Genre	
1	live or recorded text in an oral medium	a written TT suitable for oral performance according to ST transcribed verbatim	film dialogue dubbing; song lyrics
2	a written text	a TT suitable for a final transfer to oral performance	drama as performance
3	an oral ST and its transcript	TT suitable for silent reading	film subtitles
4	a written script	TT suitable for silent reading or reading aloud	drama as text; poetry

Table 1

**Forms of Genre Crossover in the Process of Translation
(Interpreting Hervey & Higgins 1992:158)**

Special mention is subsequently made to drama texts, dubbing and subtitling as different sub-genres of oral text translation that involve different requirements (ibid.:158-161). In many ways, dubbing shares with stage play translation as both forms of translation are constrained by the same general oral-genre characteristics applied in the context of dialogue translation for performance, viz., the unrepeatable linguistic and cultural transfer through the economical spoken

lines, interaction of words and body language, and verisimilitude of speech recreated in TL. However, this last feature, essential to a stage performance, further "implies that a faithful ST-oriented translation is inappropriate, since it would not sound plausible" (p.158). The reasons, they argue, are due to the fact that "[d]ramatic traditions in different cultures are usually markedly different, ...", consequently, "the translation of stage-plays will often involve an element of genre-transposition, in deference to the different expectations and tastes of TL audiences" (ibid.). On the other hand, they claim, that "complete transposition of the TT into some traditional TL genre may mean that the point is lost, and with it the merits of the ST"; therefore, they conclude, "translations of stage drama that are most successful from the performing point of view are usually based on compromises between reflecting some of the features that confer merit on the ST and adopting or adapting features of an existing TL dramatic genre" (ibid.).

Compared with drama translation, "dubbing is very difficult to do successfully" (ibid.:159) because "film dialogue presents special problems for

translators" (p.158). There is little room for 'genre transposition' between SL and TL in dubbing, for it must create an "impression that the TT heard by the audience is actually the text spoken by the characters on the screen" and, according to Hervey & Higgins, the impression "depends entirely on the skill of the dubbing specialist in synchronizing the oral TT with the movements, facial expressions and lip movements of the screen actors" (ibid.). Invariable in dubbing for the screen, these extralinguistic factors do not allow dubbing the liberty that drama translation enjoys, the kind of freedom with the spoken words licensed by the flexibilities of the theatrical re-creation.

Serving as a vital clue to making respective translation decisions appropriate for each of the media, this major difference between drama translation and film dialogue translation deserves a closer look. Both forms of translation are subject to the "running-time" (Mateo 1995:31), which depends on the length of the speech, the rate of delivery, and the relevant non-verbal language (including paralinguistic and kinesic features, movements and other visual allusions)¹⁸; but these constraining factors in relation to the spoken words operate reversely in drama translation as

compared with film dialogue translation, which is predetermined by the film medium's running time. The duration of each speech turn in a movie is permanently 'etched' on the film; in fact, the minimum requirement for setting the length of the speech significant to dubbing is confined to a series of segments between visible pauses or other meaningful signs of body language. As a consequence, the only alterable element, the rate of delivery, must comply with the basic rule that the words must match the visual by segments to the extent that the number of syllables in a segment can not be too far apart from that of the original to upset the rhythm and sacrifice audiences' comprehension. In translating for stage plays, however, the translator works in a much more relaxed framework of an envisaged performance that his translation basically prescribes instead of being prescribed. Taking the original wordage per sentence or per turn only as an approximate reference, the translator sets the dialogue running at its own pace; in virtual fact, it is the visual (the duplicated performance) that is to match the words (the dialogue in TL).

To borrow the metaphorical words of page and stage for representing the two major stages of drama/film

performance in perspective throughout the translation process, it is the written play in SL that the translation depends on and adheres to. In fact, the original drama text provides a strong base of physical reinforcement for the language within its very structure. Other components of the performance give way to speech since a stage play is in essence the art of language first and foremost. Thus dialogue stands in the spotlight and suffers little change from page to stage¹⁹. Apart from its literary nature and the stability of theatrical mise-en-scène, the authority of the original drama text as the reliable written representation of a play is also justified by the fact that theatrical performance is open to infinite interpretation and no two performances can ever be the same, because the stage presentation is not a once-for-all product like a dubbed film, but of the collaboration of the playwright, directors, designer, actors and many others on each individual account.

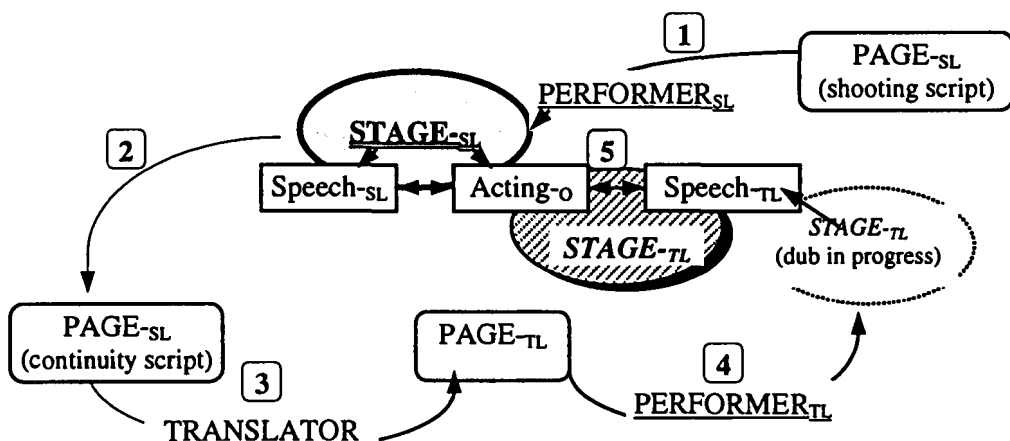

Figure 4

From Page to Stage: A Flow Diagram of Translation Process for Dubbing in Relation to the SL Text and Performance

Drama translation text is for the TL actor who is both the one to be seen as well as to be heard on stage; whereas film translation text is only for the studio actor, whose vocal performance belongs to the actor in the original film. It plays the central role in providing the SL text and the visual information, and is the primary source in film dialogue translation. A verbatim transcript of the actual dialogue spoken in a film after it is released can be obtained in the form of a continuity script. Here the advantage in simplicity of using only one source of the original in drama translation is replaced by the complication of reliance on not only the written text but also the original performance and the synchronous mixing of the new voice with the visual which is both the source and the target.

With due recognition of the value and sophistication of theatre translation as an art of its own right, in view of the procedures and technical demands involved in the two types of translation and production respectively, little need be said in defence of dubbing being a far more complicated and constrained form of translation, which deserves an independent and systematic investigation.

PART THREE: Film Dialogue Translation

2.4 Research in Film Dialogue Translation

Various methods are used to translate film dialogue for the target language audience. Pertinent literature are mainly on dubbing and/or subtitling, as they are "by far the most common forms of screen translation..." (Mason 1994:1067). In this section, only literature on either or both of these two forms are considered. Studies on dubbing and subtitling as independent subdivisions of FDT will be reviewed separately. First of all, a brief summary of the development of this translation genre in TS, followed by a look at the 'dub-sub divide'.

2.4.1 Film Dialogue Translation in TS

Up until the beginning of this decade, there had been little literature on film dialogue translation as part of Translation Studies. The situation in question, as reflected in Herbst's somewhat resentful remarks regarding research in dubbing²⁰ and Gottlieb's confirmed view of the prematurity of subtitling in TS²¹, is more explicitly summed up in the conclusion from the extensive investigation in this field by Luyken et al (1991:165):

There is no theory of [audiovisual] Language Transfer, no literature on its aesthetics nor even any universally accepted modus operandi. There are few precise descriptions of what Language Transfer should and should not do, how it could be improved, or what its scope and limitations are.

Aiming at bettering the quality of the language transfer in film/TV for the European audience, this research report is concerned with all the essential information and knowledge for professionals, programme makers, and translators for the audiovisual media. It provides answers to such questions as: How is a programme language transferred? Which method is best? What are the effects on the audience? What is the potential of

new developments? and What skills are required for the language transfer and how can they be acquired?

The findings and viewpoints offered by the contributors are valuable for backgrounding research in the field of film translation in that they not only contribute to the justification of the need for the research but also the general approach to the research problem. The chapter on the semantics of audiovisual language transfer details its definition problem, processes, problems associated with subtitling and dubbing respectively, and a pragmatic approach to translation for dubbing (see 2.4.3 below).

Another influential addition to the linguistics-informed literature on film/TV translation is made by Delabastita (1989) which presents a panoramic view of the field: past, present and future. Structuring his research along the model of translational relationships developed by Gideo Toury (Competence---Norm---performance), he has offered a systematic outline of film translation problems. First, he raises a list of questions regarding individual film translation from general queries to dubbing/subtitling-specific ones. Then, he proposes a series of open and hypothetical topics to enable the film translator to organize

his own systematic observations of the variables which govern the production of the translation, particularly cultural factors. His paper is a detailed survey on potential values of constructing an operational base for film translation.

Since these pioneering researches, remarkable advances towards establishing a place in translation studies for dubbing and subtitling have been made. The increment of literature on FDT as a new type of translation in recent years is noticeable with most of the research efforts in this area being of European provenance. Serving in the leading role of making Europe the hub of the worldwide studies in translation for the media, CTS²², EBU²³, EIM²⁴, FIT²⁵ and CTI²⁶ among other organizers have ushered in a spate of international conferences and publications under this theme since the beginning of this decade, especially 1993 onwards.

The growing interdependence between film/TV translation and translation studies is no longer a new phenomenon. The efforts to include the former as a separate subject area in TS by drawing on and spreading out its theories have come to fruition. This is observed in Gentzler's vision (1993:184),

"The impact of American television, radio, music, and international advertising, bears more and more heavily upon any discussion of translation worldwide. Not only are TS scholars branching out to consider work in film and media studies (Delabastita, 1988; 1990), but film and media scholars are also turning to translation studies for insight and terminology (Cattrysse, 1991; 1992)."

The same view is rounded out by Karamitroglou's conclusion (1996), "it is obvious that translation theory has much to gain from a systematic investigation of film translation and its idiosyncratic peculiarities".

Although this change in the status quo of FDT studies presents a pleasing contrast to the sluggish situation a few years back as mentioned above, research into in this relatively new subject area of TS is still at its infant stage and there have been constant academic concerns about the deficiency in the growth of its theory-building. For instance,

In short, the audio-visual translation in the media is a new genre, still largely unexplored in the field of translation studies. (Gambire 1994:277)

In translation studies, however, there has been a tendency to overlook these modes of

translating [i.e., dubbing and subtitling] and no large-scale empirical studies have been carried out. (Mason 1994:1069)

So far, screen/film translation has been the subject of occasional debate between practitioners and theoreticians over a number of random issues. ...film translation - a field which is still young in research terms - needs a firm theoretical framework within which its rapid development may be rationalised. (Karamitroglou 1996)²⁷

And more recently, the plea is reiterated for the need that audiovisual translation be more closely collaborated with linguistic, literary and translation studies (see Catrysse 1998:11), which reveals that to date application of TS theories relevant to FDT has been incipiently experimental, whereas the resources of linguistic theories useful for addressing practical issues in dubbing/subtitling are far from being fully identified.

2.4.2 Dubbing vs. Subtitling

The dubbing and subtitling debate had been a global phenomenon for decades (Zucker 1966; Moskowitz 1979; Pauluzzi 1983; Dean 1987; Kilborn 1989). In fact, it has been an unsubdued topic among film translation practitioners and consumers since the

choice of these two forms of film translation was made available (Kilborn 1993; Dries 1994-95; El-Sakran 1997; Karamitroglou 1998²⁸; EX 1998). The essence of the issues was and still is whether and why one method should prevail over the other, i.e., whether dubbing is linguistically and culturally more informative and beneficial than subtitling or vice versa. Some hold the view that the decision on which of the two methods to choose for a particular show should be made according to the content as well as the genre of that programme, for example, "...generally 'light modern drama' should be revoiced while 'cultural modern drama' should be subtitled." (Luyken et al 1991:130). Others deem the supremacy of one the forms over the other in the practice of a given culture to be a matter of national tradition or "a question of habit" (Ivarsson 1992:20). In a systematic way, Karamitroglou (ibid.) includes more factors in a hierarchical structure for interpreting the motivated recurring patterns of choice between subtitling and revoicing in terms of norms in audiovisual translation.

Apart from investigating the preference of film/TV audiences in different countries for dubbing or subtitling, which is a complex problem in itself²⁹,

the general professional interest as seen from the more recent literature³⁰ concerned is mainly in either comparing the two forms in their many aspects (Machefter 1987, Minchinton 1992; Mason 1994; Dries 1995) or focusing on one of the modes of language conversion (subtitling seems to be the far more favoured one) to prove it to be a better solution or to overcome some practical problems particular to that method (e.g., Voge 1977, Reid 1978, 1987; Titford 1982; Minchinton 1987; Danan 1991; Luyken et al 1991; Herbst 1995; Zabalbeascoa 1997). These studies have contributed to better understanding of not only different constraints, problems and translation strategies for dubbing and subtitling, but also their medium-driven socio-cultural, commercial and technological aspects.

2.4.3 Dubbing

Unmatched with the progress in research on subtitling, "dubbing is under-represented in scholarly literature" and "has largely been neglected as a translation genre" (Barbe 1996:255). Only a small number of linguistics-informed studies are focused on this particular area of film dialogue translation. Standing out among them, Thomas Herbst's contribution to developing theories and methodology for dubbing is widely recognized.

2.4.3.1 A Plot-oriented Translation Approach to Dubbing

Calling into question the conventional dubbing process, Thomas Herbst put forth a pragmatic approach to dubbing (see Herbst 1987,1991,1995). His argument for what he called a pragmatic plot-oriented, lip- and nucleus-sync approach, which, I think, is more than "a shift in emphasis" in translation for dubbing (ibid:23), reflects the direct influence of text linguistics and discourse analysis on film translation. By aiming at achieving translation equivalence on a new level, that of cultural context, it is expected that a translator for dubbing will be able to avoid typical elements of artificiality in dubbed dialogues such as an inconsistency of style and a lack of textuality. The principle underlying this approach of translating scene by scene rather than taking the sentence as the basic unit of translation is a leap forward from the traditional script-to-script literary approach to film dialogue translation, although the practicality of Herbst's new methodology remains to be tested in cases concerning languages other than German.

2.4.3.2 Dubbing TV Comedies

Zabalbeascoa (1994) adopts a descriptive approach to dubbing television comedies and advocates a greater awareness of the factors involved in this type of translation. The translation of jokes in the highly constrained medium for instant cross-cultural perception is examined through a step-by-step discussion of the variable nature of the factors that are operative in translation in general and comedy dubbing in particular.

Before considering the priorities and restrictions in dubbing, he distinguishes three contexts and their related factors involved in any translation process: *the context of the source text* (time, place, language, culture, society, audience, and discourse factors), *the context of the target text* with the parameters corresponding to those in the ST context, and *the translator's context* in which the translating process takes place, factors including: "the translation initiator, translator competence, specific motivation for the translator and professional conditions and constraints". (p.90) Traditionally, the consequence of this third context tends to be neglected in an assessment of a translation either as process or product, but is brought out by more recent translation theories

(e.g. the variational approach, see 2.2.4.2 above). So the confirmation here is particularly significant for leading towards a film translation theory, which would not be complete without taking into account the unique contextual factors that affect directly the performance and quality of the film translator's work.

The question of the unit of translation is addressed by treating it as one of the variables along with "equivalence" and "compensation" (p.96) with the concluding remarks that "each kind of text has its own meaningful units and sub-units" and "[t]he basic pervading unit in the translation of comedy is always the text as utterance in a communication act". (ibid.) This is consistent with the stand he makes earlier that "[a] generalized concept of a constant and unchangeable unit of translation has no real practical use... . this is also true in the case of dubbing" (p. 94). For supporting this view, two reasons are given: "that there is no stability in the length or nature of the segment of text that is translated" and "that even if the 'piece' of text to be translated were constant it cannot be interpreted independently of the context" (ibid.). On the other hand, he adds, the units of text for dubbing TV

series can be outlined in hierarchical order starting from *lip movement*, *utterance*, *pause*, to *exchange* (a group of utterance), a *scene* or a *sequence*, and further up to *chapter*, a whole series or even an entire serial. The purpose of doing so, as he vaguely puts it, is "to better describe the specific nature of translating for dubbed versions" (ibid.).

Finally, he identifies six types of jokes including international joke, national-sense-of-humour, language-dependent joke, visual joke, etc.; and, by way of relating this classification to a more general typology, he then projects two ways of classifying texts according to mode of perception to locate dubbing and subtitling in TS, one by source text types and the other by types of target renditions. The discussion ends by calling for more research on dubbing.

Despite its discursiveness, this paper is one of the existing few focusing on dubbing in a socio-cultural perspective and has shown the necessity of further studies in dubbing as a legitimate type of translation.

2.4.3.3 Prosodic Functions and Information Perception in Dubbing

Also working on television dubbing, Hoffer (1984) explores the potential misreadings and misunderstandings in cross-cultural sociolinguistic aspects of television dubbing from English to Japanese. As he observes, "... the dubbed versions sometimes do not reflect the sociolinguistic dimension of the original..." (p.801) and they "often miss the sociolinguistic meaning, including such items as the social level, the humor types, the power/solidarity information and so on carried by the vocal features and the nonverbal behavior" (p.802). The main cause lies in the fact that the translators often work only with the written text, so that vocal qualities, gestures and so on which affect the communications are not factored into the translation. He concludes that film translators should be tested on total communicative competence and not just linguistic competence.

The prosodic aspect of translating dramatic texts in relation to audiences' perception of information has been noted in Mateo (1995). In her analysis of the oral nature of dramatic discourse, she takes

note of a language-specific pattern of behaviour in a function of intonation and stress, that "in English the *discourse function* distinguishes the new bits of information (which receive sentence accent) from those parts of the message which contain known or given information and which are deaccented", whereas "[t]his is not the case in Spanish... " (p.31). She further points out that while such differences do not necessarily affect the translator of drama texts, they may create a problem for dubbing. In both cases, however, priority must be given to the analysis and transfer of these functions of stress and intonation, which "... will determine translation strategies in any language-pair if the translation process includes an oral text at either end (or at both), ..." (p.31).

2.4.3.4 The Question of Credibility and Synchronism in Dubbing

Although with no mention of the above type of problem, it is a comprehensive empirical study of dubbing American movies into German that is reported in Dopheide (1996). He starts by looking at the nature of dubbing, asserting that it serves an illusionary medium. While the translation and the dialogue writing are at its center, dubbing

involves a lot more than the act of translating - casting, acting and directing also being part of it. He then dwells on six major problems typical to dubbing from English to German, most of them being culture-bound linguistic problems, such as the translation of colloquial Americanisms, forms of address and swearwords. The question of credibility of dubbed dialogue is highlighted which includes voice casting, the final mix and economic considerations. To conclude, he also points out that "[l]iterature on the subject of dubbing continues to be poor, most of it being purely descriptive" (p.7).

In a similar context, Barbe (1996) uses data from an episode of a US sitcom to study dubbing from English into German. Not confining the scope of her research to the translation classroom as the title of her article may suggest, she considers aspects of dubbing in an all-round manner, covering a brief history of dubbing, the process of dubbing in the German system and the analysis of main characteristics of dubbing in terms of three kinds of synchrony. Teaching dubbing as a university course is addressed in the second half of the study.

Following Fodor's three criteria for successful dubbing (1976), viz., *phonetic, character and content synchrony*, she proposes three categories of synchronization in *articulatory, linguistic and social (cultural) aspects* respectively. *Articulatory* synchronization, like *phonetic synchrony*, is the concord between lip movements seen and the sounds heard. Special attention is given to the articulation of labial and labio-dental consonants, the length of pauses (Barbe *ibid.*:259) and intonation (p. 260). *Linguistic aspects* correspond to the content synchrony, with untranslatable puns and source language-specific terminology being one of the major problems for dubbing (p.260). Barbe also notes that the use of intonation to add semantic weight to the focal part of an utterance is not a feature in some languages other than English. While English tends to rely on intonation as a device to lay stress, German uses intensifiers instead. Her findings bear the same truth as of the difference in the information hierarchy of English and German documented in Doherty (1992) in that there is a tendency towards midfocus in English and endfocus in German³¹. She then summarizes that "[s]ource language influence often leads to stilted dialogues in German", which "means that, in dubbing, we meet a new meta-

language, namely the language of motion picture translations." (p.261) *Social aspects* (also termed *cultural aspects*) in the third category is expanded from Fodor's character synchrony, and is concerned with translation of gestures, taboos, humour, and particularly play on words (pp.262-263). The practice of adding dialogue lines for "special dubbing humor" (p.263) in German to ensure the perception of the original funny effect is approved as necessary for dubbing television series.

With emphasis on its commercial nature, Barbe concludes that dubbing compels a place in translation studies as a unique translation genre in which textual and visual material must be in synchrony.

While Barbe bases her supporting literature on the resources in the German language, Paquin (1998b) uses references mostly in French for his investigation into dubbing. Both of them have developed a formula of triple synchronism from Fodor's film dubbing synchrony theory. In Paquin 1998a, he refers to the three kinds of *synchronization* as *phonetic*, *semantic* and *character* (p.74); but later he uses the three headings of

phonetic synchronism, semantic synchronism and dramatic synchronism instead (1998b).

Special mention³² is also made of handling labial consonant sounds with care in dubbing from English to French to achieve *phonetic synchronization*, which is summarized as a rule of thumb to sustain lip-sync effect "that the translator/adapter cannot add a sound after the bilabial" or else "the audience would see the mouth closed and still hear a sound after the bilabial consonant" (ibid.; webpage not numbered, the same below). He sees *semantic synchronism* as a priority, in favour of which *phonetic synchronism* must be sacrificed in most case in order to fulfil the translator's main objective "that the translated text have the same meaning as the underlying text" (ibid.). *Dramatic synchronism* is considered to be "another constraint that takes precedence over *phonetic concordance*" (ibid.). Factors involved include characters' body language in synch with their speech and the choice of language register to match characterization. Realism is the key word in achieving such synchronism, the most difficult task being "the rendition of dialects, accents, swear words...", which are "the sensitive points of cultural transfers" but "can be circumvented in imaginative

ways" (ibid. 1998a:74). The principle here is that "[t]he character has to 'sound' real" and "[t]he audience must never be surprised by the text, unless that is the intent in the original... " (ibid. 1998b).

After citing examples to show how translation for dubbing really requires adaptation, Paquin concludes that, with respect to upholding synchronism, "[i]t's not just a question of translating dialogues, they have to be rewritten." (ibid.)

In summary, that dubbing needs more concentrated research in a multidisciplinary perspective is apparent and incontestable. Rather than taking it as a categorical term to define dubbing, *adaptation* should be considered only a common strategy applied to this type of translation. However its nature is described, what is urgently lacking is theoretical deliberations upon dubbing in view of the existing literature, which is inadequate and mostly empirically-oriented.

2.4.4 Subtitling

Incisive attention has been given to subtitling in the translation and interpretation literature since

early 90s (Nicholson 1995:47). In view of its relatively short history as a subtype of translation³³, literature on subtitling is considerable. Most of the studies focus on the linguistic characteristics and practical complexity of this special form of translation.

2.4.4.1 Subtitling: Characteristics, Effects of the Constraints and Problem-solving Strategies

Ivarsson (1992) is acknowledged to be the first book that embraces all topics of subtitling as an art, from its nature, history, the pros and cons of subtitling, to the do's and don'ts for the subtitler, as well as subtitle production techniques. The main part of the book is devoted to the practical aspects of the subtitler's work: how to time, edit and present the subtitles. The importance of conventions and the differences in subtitling for various media are also treated. The book is not meant to formulate any theory to enrich translation studies, but it is an all-inclusive investigation into the state of the art where subtitling is viewed as "Written Simultaneous Interpretation" (p. 7) as the handbook was originally entitled.

The same epithets are used to describe subtitling in Gambier (1994) after ten modes of interlingual transfer in audiovisual communication is enumerated (p. 276). He then poses the question of whether subtitling is 'translation' merely because the output in TL is a written text according to the end-product-oriented definitions of *translation* and *interpretation*, and concludes that the difference between them is not clear-cut but forms a continuum, so is and does that of oral and written genres (p. 279).

This question of whether the translation-interpretation dichotomy can be related directly to the written-spoken mode distinction of subtitling and dubbing is also raised in Scandura (1993). She holds the view that the mode of source language input used by the film translator during the rendition defines the nature of the activity as either translation or interpretation. In the case of subtitling, "... when you do not have the script and have to listen to the film to be able to translate, a very common thing in some countries ... you are interpreting" (p. 446). Her paper attempts to confirm her hypothesis that film translation is a hybrid between translation and

interpretation and that its problems correspond to both activities (ibid.).

On the other hand, Mason (1994) uses the phrase "semi-verbatim translation of what is heard [on screen]" (p.1066) to refer to subtitling. He lists three contextual constraints on subtitling: namely, speech to be represented in written form; the available space for subtitles; and the sequence of speech acts to be preserved and perceived, as it occurs, in subtitles which have to be concise and irretrievable. The consequence of these constraints gives rise to types of loss of the elements in the original dialogue in terms of formal features, the full function of speech acts, spoken language features and discourse markers. However, the article proposes little solution to these problems.

Ways to solve the problems of ambiguity as the main obstacle in subtitling are suggested in Viezzi (1992) with reference to examples of English film dialogue translated into Italian subtitles. One of the reasons given to account for lack of clarity in subtitles is that "they are often the translation of the film script rather than the translation of

the soundtrack." (p.84; Cf. review of Reid 1990:101 below).

Having identified two kinds of 'media-defined constraints' of subtitling - formal (quantitative) and textual (qualitative) constraints, Gottlieb (1992) puts forward 10 subtitling strategies as solutions to problems special to this type of "tightrope translation" (p. 166), viz., expansion, paraphrase, transfer, imitation, transcription, dislocation, condensation decimation, deletion and resignation. He then analyses a feature film subtitled in Danish to show the effectiveness of these strategies in reducing loss of information in subtitling by tallying the distribution of the strategies as applied with examples provided³⁴.

In the above study, subtitling is defined as *written, additive, immediate, synchronous, polymedial* translation; whereas in Gottlieb (1994), another of his numerous seminal studies, he dwells on the 'diagonal' nature of subtitling, highlighting the fact that it is a dynamic type of translation that involves the switch from spoken to written mode. Then he outlines the necessary skills by which successful subtitlers overcome the complexities resulting from the changes in mode and timing. He also details nine basic fields to

consider when creating and evaluating interlingual subtitles. Among these guidelines, the deliberation on a "congenial segmentation of dialog" (p.109) deserves special mention. Interpreting the segmentation methodology in Reid (1990), he reaffirms her distinction between *grammatical*, *rhetorical* and *visual* segmentation of the SL dialogue to be shaped into TL subtitles and emphasizes the prevalence of rhetorical segmentation (on the basis of speech rhythm) in general practice. He adds, "[e]very well-formed subtitle should read as a self-contained entity, but in utterances covering more than one segment, a consistent thread must be preserved" (Gottlieb *ibid.*:110).

The great value of Reid's original findings in subtitling studies lies also in her emphasis on the important function of intonation in film dialogue. Calling it "the greatest stumbling block" (Reid *ibid.*:101) the genre change from spoken to written words in the case of subtitling, she points out that it reverses the presentation process of the screen actor, "who turned the written words of his script into spoken ones" (*ibid.*), and thereby lacks intonation. So it is a difficult task for the subtitler to convey "the very subtle shades of

intonation that are related to the subtext, and which give a phrase its meaning, or even make it mean the very opposite from what it looks like when printed" (ibid.). In Reid (1991), she reiterates that subtitlers, in performing the interpretative function contained in the process of subtitling as a *communicative translation*, should aim at transposing the spoken text together with its non-verbal concepts into a written text to minimize the effects of the genre crossover constraint.

Taking subtitling as a typical example of the crossover between oral and written genres in TS, Hervey & Higgins (1992) treat the subject in a special chapter from a pedagogical perspective. Supplemented by its accompanying Teachers' Handbook, subtitling, its linguistic characteristics, technical requirements and procedures and translation strategies, is explicated. In analysing the sample subtitling exercise, the key issue of changing or retaining the SL word order in subtitling is initially addressed. In the case of rendering a dialogue list from French into English with regard to an afterthought structure "where important new information is fed in 'retrospectively', in a subordinate clause" (p.163), the reverse SL order

is changed in the TT and defended for the express purpose of subtitling. This is rationalized, yet not without ambiguity, as follows:

Normally, 'improving' a SL in this or any other way is not necessary or desirable, but it is sometimes a serious option in oral-to-oral translation ... , in case of crossover between oral and written texts (... especially in subtitling), and, ... in empirical/ descriptive or persuasive/prescriptive texts where the paramount concern is absolutely clarity. (ibid.)

2.4.4.2 Applications of Linguistic Theories to Subtitling

An earlier attempt to apply linguistic theories to subtitling can be seen in Titford (1982), who introduces from text linguistics the notion of *textuality* to the process of translation for subtitling. He relates the distinctions between *cohesion* and *coherence*, and *text* and *discourse*, to the description of subtitling translation to find better solutions to the tension between what is in the original discourse and what the translator can fit into his text. Having described types of tension problems peculiar to subtitling in terms of three overlapping dimensions, he illustrates instances of mediating satisfactorily visual-linguistic clashes in subtitling a number of scenes

from one American film into German. By following the same theory, Hatim & Mason (1990) cite two examples of establishing discourse cohesion in subtitled texts by restructuring the surface form (p.29) and using "text reference" (p.203). These original applications of discourse analysis tools to subtitling have great values for solving practical problems as well as for directing to a new approach to audio-visual translation.

Kovačić (1992) takes the initiative to study subtitling from linguistic perspectives in a systematic manner. Basing her theoretical framework on systemic linguistics, she investigates the problem of making choices of omission in the production of subtitles. This "key question in any analysis of subtitles" (Kovačić 1996a:5) is further examined in her later studies (e.g. Kovačić 1994, 1996) in terms of *reductions* by drawing on the principles of Relevance Theory (Sperber and Wilson 1986), in addition to Halliday's model of linguistic functions as applied in her earlier discussion on this phenomenon.

The reduction in the TL subtitles is listed as one of the special textual constraints (as distinguished from technical constraints), along

with "the additional visual component" and "the switch from oral to written mediums", in de Linde (1995:11). Her study on this subject leads to the conclusion that reductions involved in subtitling are based on consistent principles - they are "systematic and not random" (p. 19).

2.4.4.3 Other Major Studies on Subtitling

Nedergaard-Larsen (1993) analyzes four French films which are subtitled for Danish and Swedish television audiences. She concentrates on the difficulty in translating "culture-bound" differences between the two languages and two societies and indicates the strategies used by subtitlers when confronted by these phenomena. Choosing a good strategy to render the film dialogue bound to a culture/language-specific problem is considered crucial to successful subtitling. But the subtitler should have a clear understanding of the factors to consider before selecting a strategy, or evaluating the one that has been applied. Illustrated by a great variety of specific examples, eight categories of strategy are provided, namely, *transfer (identity/exotism)*, *transfer (imitation)*, *direct translation*, *explicitation*, *paraphrase*, *situational adaptation*, *cultural adaptation* and *omission*. The analysis of

these examples shows a norm-governed tendency to preserve the foreign colour of the dialogue while remaining faithful to the source language expression whenever possible. This paper represents one of the few influential studies that offer an in-depth overview of both the theory and practice of subtitling.

Research concerned with subtitler training occupies a distinct place in the development of subtitling as a growing sub-division in TS. Contributions to investigating its formation and operation in translation curriculum have been significantly accumulative in recent years (noticeably, Hervey & Higgins 1992, Gottlieb 1992, 1994, 1995, Brondeel 1994, Kovačić 1996b, 1998, James 1998, James et al 1996 and Klerkx 1998). Prescriptive in orientation, these studies are valuable to the build-up of a theoretical and practical database of, not only the training discipline, but also film subtitling per se.

Adopting a clearly prescriptive approach, Karamitroglou (1998) sets out to provide a unique set of subtitling standards that is meant to bridge the different subtitling conventions currently operating within the various European countries.

This comprehensive investigation marks a shift of the research trend from descriptive studies of the existing subtitling practices being followed in these countries to rule-dictated formulations of a unifying code of practices that would not violate the already established conventions while it is enforced. New technological developments in mass media and communication (e.g. satellite broadcasting and digital TV) have called for the necessity of creating a pan-European television audience and, at the same time, provided the quantitative basis for such an initial attempt.

In the course of proposing a technically detailed set of standards for subtitling, this study also addresses issues ranging from segmentation principles to different translation strategies for rendering different context-constrained linguistic items, in particular, those with regard to culture-specific elements. The main points made are outlined as follows.

- (1) Subtitles should transfer the spoken dialogue as faithfully as possible in terms of both content and timing.
- (2) Subtitles should be presented in segments at the highest syntactic nodes possible, because the higher the rank, the greater the semantic content and the more complete the chunk of information

presented to the audience per input in terms of cognitive capacity.

(3) A decision as to which linguistic items to omit or to keep depends on their relative contribution as pieces of information to the target film as a whole. The subtitler should try to keep a fine balance between retaining a maximum of the original dialogue and allowing ample time for the audience to process the non-verbal messages from the film. Categories of linguistic items that could be omitted are *padding expressions, tautological cumulative adjectives/adverbs, and responsive expressions.*

(4) Complex syntactic structures should be replaced by simplified ones. The eight categories of altering syntactic patterns for this purpose include: *active for passive constructions, positive for negative expressions, temporal prepositional phrases for temporal subordinate clauses, etc.*

(5) Other considerations in the subtitling process are given to principles on retaining linguistic items of the original, treating acronyms, apostrophes, numerals and symbols, and rendering dialects and taboo words.

(6) Lastly, there is no standard guideline for the transfer of culture-specific linguistic elements; however, the five possible alternatives for such a transfer are: 1) *cultural transfer*, 2) *transposition*, 3) *transposition with explanation*, 4) *neutralisation (plain explanation)*, and 5) *omission*. The choice of which strategy to apply

depends on the parameters governing the text and context in which the culture-specific element is embedded.

2.4.5 Summary

From the above survey of the literature on FDT, these concluding points can be made.

1. The place of dubbing and subtitling in TS as a translation genre has been initially established and its potential research values have been widely recognized.
2. The rivalry in the dub-sub dichotomy has yielded little meaningful result as to which is the winner; instead, it has strengthened the independent status of both as two complementary, rather than conflicting, forms of film translation. The issue stemming from the age-old debate is now not so much an appraisal of one method being superior to the other, as a reality of which one being the more appropriate choice or more popular preference that is not just determined by tradition but a combination of textual and contextual factors governing the screen product as well.
3. Research in film dialogue translation in recent years has benefited either directly from the principles and instruments of linguistics or its

applications in translation studies. However, it is not yet in evidence that an encouraging number of breakthroughs have been made in this field whereby new findings, theories and methodologies have replenished the traditional literature and mode of thinking. The foundation efforts to justify and describe dubbing and subtitling as two types of constrained translation with respect to their typological nature, unique contexts, and merits and demerits have become too persistent to necessitate further elaboration. What is needed is more focused looks at the key issues in the subject area, such as those that concern the SLT³⁵ process and quality assessment theories particular to film dialogue translation. The current tendency that empirical/descriptive studies surpass theoretical/prescriptive studies in the literature on FDT should be altered.

4. Obviously, compared with the existing knowledge of subtitling, more research needs to be pursued in dubbing.

With regard to English-to-Chinese dubbing, research into the language/culture-specific translation problems and issues in this area, has remained undocumented, which warrants a special survey.

2.5 Trends and Tendencies in China

Studies in translation in China are copious and fruitful, but most tend to treat translation either as a verbal art or a cross-language skill, but not as a science (Wang 1991; Zhang 1993). On the other hand, achievements in audiovisual translation products by Chinese dubbing practitioners far outgrow their research interests in dubbing as translation³⁶. Two main reasons may account for this phenomenon as far as the situation in China is concerned. First, even in its monolingual setting, the genre of spoken language, of which dramatic dialogue is a special form, has never become a subject of wide academic recognition³⁷; let alone film dialogue. Second, dubbing has been regarded as a performing art rather than a bona fide type of translation. As a matter of fact, typology of dramatic discourse translation per se is especially under-researched³⁸. Small wonder very little is found in literature on film dialogue translation research, except for reports from the biannual National Conference on Work in Dubbing for Television (since 1989) and discussions of dubbing from a non-translation point of view at regional seminars (occasional), both of which are focused on the artistic uses of language or television broadcasting service in general³⁹. Thoughts and

comments on dubbing can sometimes be spotted in popular magazines on cinema or the entertainment page of newspapers; but for expert opinions, one can hardly find an article that treats dubbing as a topic for translation studies.

2.5.1 The State of the Art

2.5.1.1 The Practice

China has a long-standing dubbing history which can be traced back to as early as 1947 when a newly released Chinese feature film *Jia` Feng` Xu` Huang`* (*A Wrong Match*) produced by Wenhua Film Company was dubbed into English (translated by the director of the original film, Huang Zuolin), and exported overseas⁴⁰. However, the official record tends to mark *Pu`Tong` Yi` Bing`* (*An Ordinary Soldier*), a Russian film dubbed into Mandarin by the then Translation Section of Changchun Film Studio, as the first *yi`zhi`pian`* (translated-and-dubbed film), which symbolizes the birth of the first national dubbing team in July 1948. Since the successful completion of the Chinese version of that film 11 months later, it had been one of the studio's main tasks to translate and dub Soviet films for the Chinese audience at a much faster rate until the mid 60s. The 1950s turned out to be

a very productive decade for this newly-founded dubbing base with a total of 433 foreign language films from 25 different countries dubbed into Mandarin⁴¹, a great majority of which being films imported from the former Soviet Union. Thus the dubbing section of the studio became a fully-fledged dubbing specialist and has been operating in this capacity ever since, only with some down periods in the intervening years because of the disruptions of the nation-wide political movements. One of its recent accomplishments is the dubbing of the American movie *The Mask* into its Mandarin version *Mianju* (1997; Translated by MENG Chao)⁴².

Following Changchun, the Shanghai Film Studio translated and dubbed another Russian film *Tuan'de Er'zi* (*Son of the Youth League*) a few months after *Pu'tong Yi Bing* in 1949. Two years later, Mr. Chen Xuyi, then head of the translation section attached to the Shanghai Film Studio, came to Changchun as a film translator in residence to learn from his colleagues in film dubbing. In 1957, growing out of Chen's translation group, the Shanghai Film Dubbing Studio came into being, which had been technically steered by him for more than 30 years from then on. In its 40 years' history, Shanghai Dubbing Studio has made remarkable

achievements in making hundreds of well-received dubbed films to cater for millions of Chinese audiences. Up to 1989, it had produced 837 dubbed films (out of which, 731 feature films, 106 films of other categories) from 47 countries/regions, plus 128 dubbed episodes of imported TV series (Yiyun 1991:85). In recent years, the annual output figure of dubbed films from the Studio has kept escalating to new heights. Take for instance, the 1994 minimum target number of imported feature films (including animated films) assigned to the Studio by the CFIEC⁴³ was 300, whereas its Northeast counterpart Changchun was to produce 100 dubbed film in the same year⁴⁴. Since 1995, its reputation as one of the three dubbing giants in China (along with the Changchun Film Studio and the Beijing Film Studio) has been further strengthened by a large turnout of the Chinese-speaking Hollywood 'megahit' movies and the winning of many national awards for best dubbed pictures.

Being a versatile and prolific film translator himself, Chen Xuyi translated during his lifetime more than 40 foreign-language feature films, most of them from English and all dubbed into Mandarin with positive audience responses. His commanding professionalism as displayed in his translations of

many cinematic classics and his commitment to his leading role of Studio Manager (or *lao`Chang`zhang`*, meaning our-longtime-factory-director, a respectful title that he has been known as), earned him wide acclaims as one of China's greatest film translators. His innovative "*pian`duan`pei`yin`fa`*" ("pause-bound translation methodology"), was adopted as part of the Studio's standard working routine in translating-dubbing of films for many years (Yiyuan *ibid.*: 87; *China Encyclopaedia - Film* 1991:52).

Chen's pause-bound method is a systematic, translator-centred approach to the dubbing procedures. It prioritizes the translator's responsibility for the optimal match of his written translation with the relevant performance onscreen, and the dubbing director's involvement in the translation process. Before setting about translating the dialogue, the translator is required to view the original film until familiar with the source text in the film's context, with particular attention paid to the visual information that relates to the dialogue. Then the translator marks out all the major audible pauses sentence by sentence in the original script according to the

dialogue soundtrack, so as to draft his translation in such a way that the number of syllables in between the pauses should approximate those of the corresponding part in the original, and the TL phonemes at the beginning and end of each segment match the visible lip movements in the picture. After the TL script is written, it is carefully checked against the picture at least twice to make sure the words fit in properly, and modifications are made where necessary. This is done paragraph by paragraph and reel by reel, together with the dubbing director and, in most cases, a kou'xing'yuan' (lip-sync technician) as well. Apart from incorporating performability and the lip-sync control into his translation to make the SL dialogue sound more true to the original, the translator aims, through this joint test-run, not only to have his dialogue script finalized but also to achieve a thorough understanding of the target movie, from the theme and plots to the pragmatic aspects of the language including the sociolinguistic information about the actor on screen, so that the dubbing director is better informed and prepared for organizing and conducting the dubbing cast⁴⁵.

However, this ideal scenario of closely-knit teamwork from very early on in the FDT process found few copies in reality. As a consequence of the translator's triply⁴⁶ constrained working context in China, his/her pivotal role in dubbing is not widely recognized, but reduced to auxiliary in most cases⁴⁷. To the Chinese dubbing executant, whose position is held to be far more than the puppet stand-in communicator, dubbing is but an artistic enterprise where the primary goal is to keep the original characterization alive and unaltered with their creation of a new "sound image". Voice-type matching, effective acting and lip-synchronization are what they are after. The soundness of the information truthfulness and semantic integrity of the TL dialogue script is taken for granted and rarely queried. In the event of doubt and dilemma it is common practice to reword the problem lines at the director's own discretion according to whatever information is available from the TL script and the picture.

On the other hand, most translators for film/TV dubbing, whose responsibility is assumed just to derive a readable (not necessarily sayable!) dialogue script from the original one, neither pay adequate attention to how the original dialogue is

said, nor work in conjunction with the visual; and, therefore, do not expect their translation to be performable without further treatment. It is not uncommon to find their work in violation of even the general principles of dramatic-text translation in terms of the original rhythm, texture, information focus and colloquial style including grammatical structure and lexis, not to mention the technicalities of dubbing. The average dubbing translator for TV stations, not being involved in, nor even concerned about, the revoicing process, tends to ignore the media constraints as much as possible under the external time pressure and self-depreciation at their willing expense of having their "raw translation" freely modified.

Nevertheless, this undesirable yet not unusual set of working circumstances, mismanaged by the FDT translator in China perhaps, does not disparage the potential value of Chen's legacy, especially his effort to fully exercise the translator's authority of being the first and main source of the verbal information from the original film to make sense of SL and set the tone for TL. In any case, the translator, in the "joint effort of a team of professionals" (Zabalbeascoa 1994:95) in the making of a dubbed film, remains in his/her unique role of

encoding the original FD functions in another language for the others to interpret and act upon.

In the case of the Shanghai Television Station for instance, the dubbing director (with the target-language competence or not) is proclaimed to be "the heart and soul of the entire dubbing process" and "the final editor of the translated dialogue" (ShanghaiTV 1991:5), which is actually a dogma held by most TV stations in China. However, the translator's work is also recognized as the whole basis of dubbing and the emphasis on the dubbing director's responsibility for the spotting (together with the translator as can be assumed from Fig. 5) was obviously influenced by Chen's methodology.

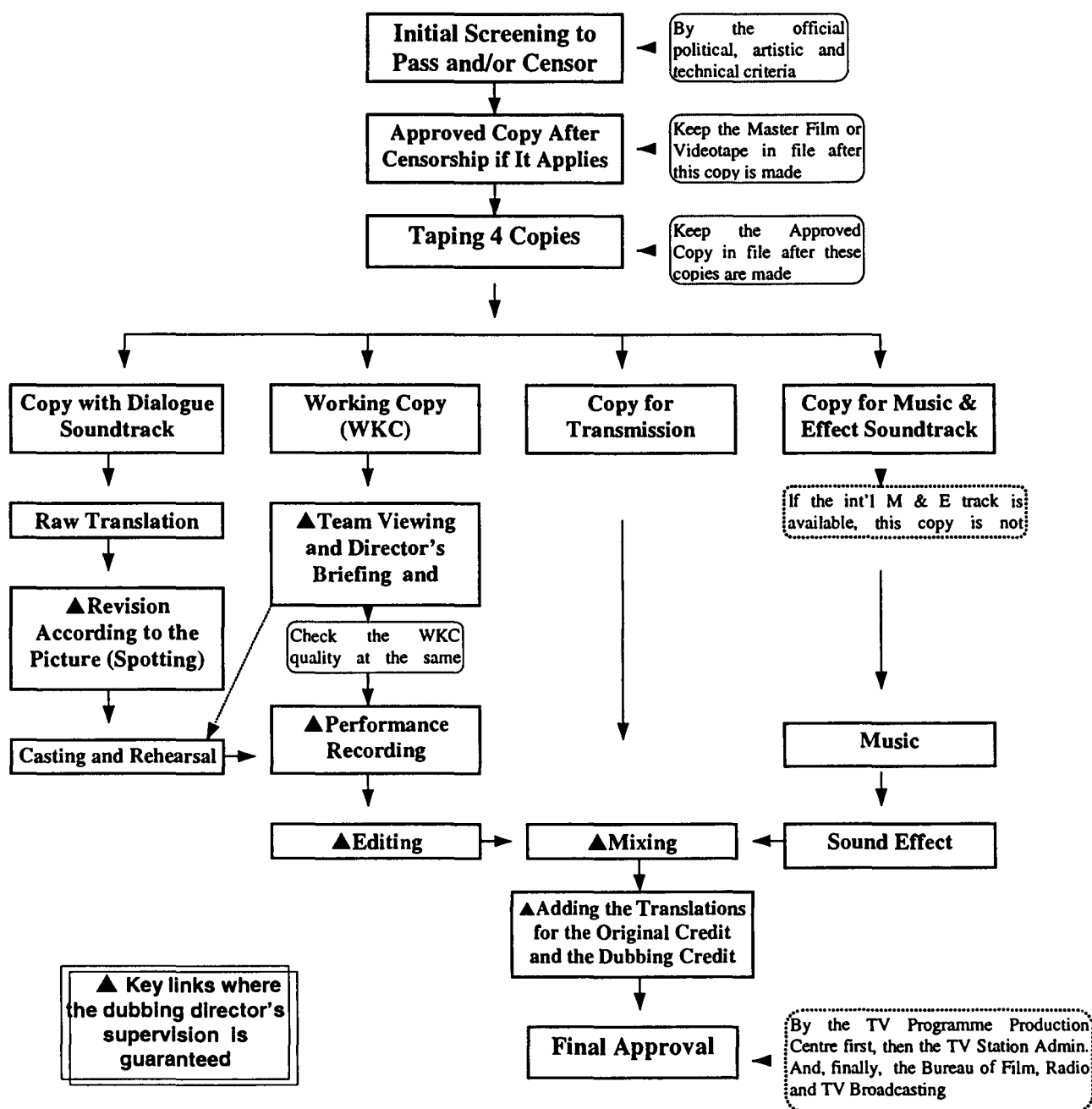

Figure 5

Steps taken for dubbing a foreign film into Chinese by the Shanghai Television Station (interpreted according to ShanghaiTV 1991:3)

In practice, this flowchart of dubbing for television represents in general the working procedures for the relevant department of other major TV stations in China as well⁴⁸.

2.5.1.2 The Theory

Two significant pleas for pursuing research into audiovisual language and its translation reflect the theoretical paucity in the development of China's film studies with respect to FTD. In 1984, at the First Annual Conference on Film Studies of the China Association of Film Critics, Zhou Chuanji, a well-known film theorist and linguist, delivered a speech entitled "China Needs Professional Film Critics in Audiovisual Language" (Zhou 1988) in which he points out that research on film theories was far behind practices in film making in China. He then expounds on the importance of understanding sound-image relationship in creating or judging a film and criticizes a series of mishandled cases for lack of concern and knowledge about the state of the art in this area by Chinese film practitioners and theorists. Citing the viewing of an imported film for the purposes of film critique or censorship by customarily turning off the original soundtrack to concentrate on the voiceover-style interpretation, he lashes out at the ignorance of the devastating effect of such common practice on the evaluation of a foreign film, calling it "a perfectly unequivocal way to show the extent of superficiality of our film specialists' knowledge about what sound is to

a film" (idib.:439, my translation). Without losing pungency, he continues, "... including professional screenwriters, film critics, film theorists, film aestheticians, these special audiences unanimously opt for no sound but the translator's voice when watching a film otherwise incomprehensible to them ... because they mean to hear the dialogue, but do not see the visual language and their interdependence. Neither do they know that, to mute the sound is to blind our film workers from seeing how far advanced the level of the art of sound-picture co-ordination has been attained by our foreign colleagues abroad." (ibid., my translation).

Nine years later in 1993 at the Third National Conference on Work in Dubbing for Television⁴⁹, Liu Siliang, Vice Minister of Radio, Film and TV, called on people working in this field to start new-concept theory building in dubbing for film/TV. In his speech, he denounces the prolonged apathy towards research on dubbing, which he identifies as "a discipline of learning and a 'systems engineering' demanding special studies" (Liu 1993:1, my translation).

Uplifting as it sounds, the positive impact of this timely 'pep talk' has not been significantly evidenced. Little progress in research on dubbing has been made from what was the state of affairs as spotted from the existing literature back to the beginning of this decade; however, the major theories have been consistently in agreement among Chinese dubbing professionals since a further decade back.

Among other literature on dubbing in China, two articles (Li 1992; Yiyun 1991) and two conference papers (Che 1991; Wu 1991; unpublished) are of special value in that they reflect the current trend and tendency as well as the conventional attitude towards dubbing (and subtitling) among Chinese professionals in this field. Representing the three leading national dubbing studios of Shanghai, Changchun and Beijing respectively, the authors offer extensive yet similar views with regard to the nature and objectives of dubbing, strategies and techniques as well as roles and relationships involved in the dubbing process. Their different perspectives can be focused on the same deliberations in three aspects, viz., Dubbing Supremacy, the Third Creation Theory, and the

Director-centred Teamwork Approach. The following is my interpretative summary of their findings.

Dubbing Supremacy

The multimillion audience in China have become so accustomed to dubbed foreign films and TV programmes that this tradition is almost as "impossible" to change as subtitling is to Greece (Papadakis, I. 1998:65). To date, dubbing is still the only government approved mode of translating foreign-language audiovisual imports for public viewing in cinemas and on TV. For those who prefer hearing the original soundtrack, other choices are becoming more and more available than the weekly educational TV programme that shows the subtitled version of a transmitted dubbed film or teleplay to cater for foreign language learners. Nevertheless, to do this, they have to access to the ancillary markets like satellite TV, cable TV and other a/v materials such as home videos, VCDs and LCDs, or just wait for an international film festival that may provide such a chance. Even though they have become rich resources of subtitled foreign movies and TV plays/series since the late 80s, there has never been an arena for rivalry between dubbing and subtitling in China. Apart from the unchanged national policy and the prevalent audience's

preference, the dubbing monopoly is also gained from the longtime prejudice against subtitling as an inferior form of film translation in the circle of the professionals.

It is in the opinion of many Chinese dubbing experts that subtitles help viewers to understand the basic plot of a film at their best, but they can never convey the full meaning of the dialogue because of their brevity as a result of a heavy reduction of the original spoken words under the medium constraints. In fact, it is widely believed that subtitling is devastating to the aesthetic integrity of film as an audiovisual art, since it requires the audience to read these distracting (though necessary) "literacy flashcards" (Li 1992:54) while watching the pictures. Another witty simile frequently heard is that, by relying on subtitles, a film is virtually reduced to "a moving picture-book" (ibid.). Naturally, the conclusion has always been that subtitling is not the solution. This is just where the true value of dubbing lies: "It resolves the language problem by revoicing the characters on screen and reinstating the fusion of sound and picture in the meantime. Thus, with the intactness of image and characterisation restored, it enables the foreign

audience to experience the same spirit, harmony and poetics of the original cinematic work of art" (ibid.).

This or other similar appraisal of dubbing, foiled by the disadvantages of subtitling, is generally held as a mission statement for film translators and dubbers, which is sustained by the optimism about two unflagging resources: the unflagging patronage for dubbed films by a gigantic audience "who, after the week's hard work, are used to enjoying themselves by watching a well-dubbed foreign movie" (Che 1991:36; my translation) and the expanding ranks of overzealous dubbing performers, whose motivation to earn the credit for 'sounding just like the screen actor' or the laurels of 'the Chinese counterpart of the screen character', is stronger than for anything else. Because of such unsolicited devotion from the dubbing personnel and other factors such as the pragmatism adopted in the whole process, dubbing a foreign language media product in China is done at far less cost and in a far shorter time than usual. Despite the truism that "dubbing is a far more complex and expensive business than subtitling" (Kilborn 1989:423), it has never been an economic concern to the Chinese policy-makers and producers.

To sum up, the government policy, the audience preference and the deep-rooted conviction that dubbing is the best mode for film translation are the three main causes that have left no legitimate place for subtitling in the official media and FDT forum in China. Perhaps that explains why, in the Chinese terminology, *dian`-ying` yi`-zhi`* (literally *film translation-making*) means exclusively *dubbing* and, similarly, *yi`-zhi` pian`* (*translated-made film*) refers to dubbed films only.

However, with "the breakup of the 'distribution' monopoly" that started in 1995 when the three "official studios" of Changchun, Shanghai and Beijing were allowed to compete with the CFIEC for distribution rights, "[s]imilar privileges are expected to be granted gradually to China's 26 studios" (Major 1996). China, "the world's most coveted untapped market" of foreign media products (*ibid.*), will be more tolerant to and in need of other forms of language conversion and it can well be predicated that subtitling will no longer be excluded from being a desired option in the science and service of FDT in China's foreseeable future.

The Third Creation Theory

Is dubbing a creation? Is a dubbed film/teleplay an art? If it is, what art is it? As a form of art, what common characteristics does it share with the art of film or that of drama? How different is it from these other forms of performing art? What is the nature and methodology of dubbing as a creative art? These are the favourite topics that are found in the literature and discussions by the Chinese experts in dubbing. The following answers (see e.g., Li 1992; Wu 1991) represent their similar viewpoints.

- Dubbing is a special subject that needs immediate investigation.
- A dubbed film/teleplay, as a special form of art, is distinguished from film, teleplay and stage drama.
- Like the latter forms of art, a dubbed film/teleplay is a comprehensive art, which is the product of teamwork.
- Dubbing is the *third creation* based on the *second creation* (the making of the original film) which is derived from the *first creation* (the writing of the original screenplay).



Figure 6

Dubbing as Third Creation Art

The third-creation theory is actually the bible to the Chinese dubbers. It is based on the premise that dubbing is the total replacement of dialogue (sometimes the whole soundtrack) which involves the joint effort of the whole crew of people, including the translator, the dubbing director, the actor and sound technicians, to create and synthesize a new work of art within and out of the original film. Like the creation of this source film, the third time creation of the same story is by no means a simple audio code substitution - it runs through the entire process of the filming in terms of background research, casting, rehearsal, performing, characterization, editing, M & E creation and mixing. Moreover, all this must act under the special constraints. The awareness of the nature of dubbing as such a creation can help resolve most existing problems in dubbed films for which the translator, director and actor are responsible in each of their own working contexts, as these problems stem from the limitation of the

outdated conception with regard to the film art, i.e., the failure to understand the full meaning of the creation of sound in the multi-dimensional system of a film, which the theory in question elucidates.

While this standard theory emphasizes the relevance of socio-cultural as well as theatrical context to the characters' speech which adds an extra interpretative dimension of the dubbing performance, it fails to recognize that dubbing is by nature a type of translation nor does it distinguish the dubbing (process) from a dubbed film (product). The reason for this confusion should be ascribed to the major premise of the theory that inflates the role of dialogue performance in a film by elevating dubbing (a component part of motion-picture making) and a dubbed film (a film genre) to an audiovisual art comparable to film and drama, although it does acknowledge the parasitical relation of dubbing to the original film. The implication of identifying dubbing as an autonomous art form parallel to film per se is that it is the dubbing director and actor who are the creator of the art, whereas what the translator (analogous to the screenwriter, who is independent of the filming/dubbing) contributes, in

spite of its essentiality, is an unfinished work to be completed by the former.

The Director-centred Teamwork Approach

Another standard theory elaborates on the joint effort of the translator, director and actor in the making of a dubbed film. This three-in-one co-operation formula theoretically focuses on the dubbing director, even though the translator is always worded first in the trinity (Li 1992:52; Yiyun 1991:86; Wu 1991:38; Che 1991:29; ShanghaiTV 1991:4). The main deliberations of the theory are: description of the responsibilities of the translator, director and actor, their relationships to one another and the power of the director in commanding the performance of voice, words and delivery as three essential interactive components of dubbing.

Translator

The TL script is regarded as the basis of dubbing. "The quality of the translation is the primary factor affecting the quality of a dubbed film." (Yiyun 1991:86) Demands on translating the dialogue are different from those on other forms of literary translation, because a dubbed film projects the audiovisual experience on the audience

once and for all, so words must be perceptible the first time for the audience - hence it is more difficult. Special requirements for the translator in preparing the script for dubbing include the following:

- a) The TL dialogue must be both literarily sound and colloquially sounding;
- b) It must retain the original characterisation - words must suit the screen image;
- c) To fit words in the lip movement, good translation skill is required to reduce the number of syllables without losing the semantic content or to expand the utterance without sounding empty;
- d) As no footnote is allowed in dubbing, the translator must be familiar with the source culture and transfer the meaning by using the right strategy in TL, e.g., the pronouns "he/his" and "she/her" when translated into the Chinese *ta*/*de*, can be confusing and therefore need to be specified. Also, "[i]n some cases, just a few words can function as the linkage between scenes; therefore, how to handle these key words is vital to the flow of the film." (Li 1992:53).
- e) Foul words and other "culturally-contaminating language" that are subject to the censorship but can not be avoided by the translator must to be put into some inoffensive or

politically-correct equivalents. Satisfactory examples are the euphemistic coinages in Chinese, "a rectum expert", "I'll give you a shot in a little while", etc., instead of the "dirty words" in the original dialogue between gay partners (Li *ibid*:54).

In short, the dialogue script has a direct bearing on the quality of dubbing. A good translator should have wide knowledge of both source and target cultures and should be "a very literary and well-cultivated person by training" (*ibid.*) His/her mission is to be as competent and resourceful as possible in expressing the original meaning with rich verbal means and subtle, witty renderings that "come surprisingly close to the source language" (*ibid.*).

Actor

The dubbing is a special kind of performing art in that dubbing actors "dance with shackles". They should aim at "breaking off the chains to be themselves and, at the same time, to vanish themselves into the screen characters" (Yiyun 1991:87), using the appropriate voice projecting skills to match the distinctive ways of speaking, the stress, rhythm, intonation and undertones to speak for the latter as if of one person (*ibid.*:87,

89; Li 1992:55-56; Wu 1991:43-44). To achieve this goal, the actor should bear these tips in mind:

- a) Find the feelings - create a voice image to suit the screen actor by entering his/her world. Dubbing is never a "two-man collaborate" comic show, nor "tracing characters on the red template" for practising calligraphy (Li *ibid*:54).
- b) Apart from getting pause, stress (semantic and attitudinal) right, dubbers should express what is unsaid, that is, speak in the right tone. He/she must avoid speaking in a translating voice.
- c) The dubbing stimulus-response "communication circle": the full source image → dubbing actor → the muted screen actor → target representation of the full image. (*ibid*.:55)
- d) In following the above "line of perceptual interflow", "four principles of language" (*ibid*.:56) must be observed, viz. speaking with a purpose (ideological orientation), speaking in a genuine manner (rational motivation), speaking in a naturalistic manner (substantial reference), and speaking with clarity (emotive expression)⁵⁰.

Director

The director's responsibility is described as "the overall control of a faithful renovation of the

original film's artistic style and structure" after dubbing (Li 1992:57). "The success or failure of a dubbed film hinges on the director's job" (Che 1991:29), which is similar to "the conductor of a symphony orchestra" (Yiyun 1991:87). His/her main tasks include:

- a) Giving approval to the final version of dialogue script for the actor after discussions with the translator;
- b) Organizing the dubbing cast and assigning roles to actors. To choose the right actor for the right screen role is "half the battle" (ShanghaiTV 1991:5), "a crucial step to success" (Li *ibid.*:57). To achieve this, the director must have an insight into both the roles on screen and the actors in the studio with respect to voice type, voice quality and adaptability, and personal disposition.
- c) Introducing the film and "setting the tone" of the dialogue performance before rehearsal.
- d) Directing the dubbing performance.
- e) Editing the dialogue soundtrack with the sound technician after dubbing.

The relationships and three essential components in the dubbing process

Words, voice and delivery are considered three essential components of the dubbing process (Che 1991:34). To interpret the relationships between these components and those of the dubbing team and between one another among themselves, Figure 7 gives a simplified structural representation involving the responsibilities of the translator, actor and director for each of the links in the dubbing process from 'words on page' to 'words on stage'.

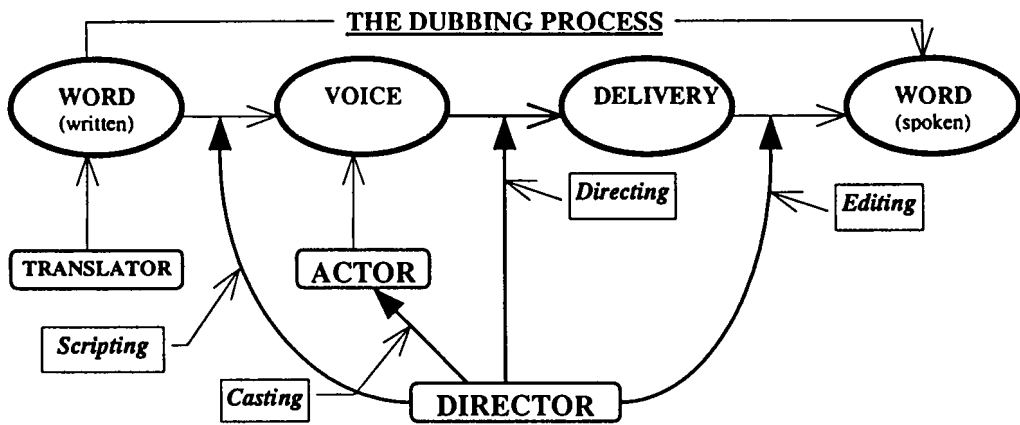

Figure 7

The Relationships in the Joint Effect of Dubbing from Script to Soundtrack

The *translator* provides the dialogue script as written WORDS to the *actor* who uses VOICE as the vehicle to DELIVER the sound and meaning of the words to the screen, so that the written words turn into spoken words under the direction of the

director towards the completion of the dubbing process. The director is in charge of four specific processes: *scripting* (polishing the translated dialogue for the actor), *casting* (picking actors for the dubbing), *directing* (conducting the delivery/performance) and *editing* (finalizing the new dialogue soundtrack before mixing). The theory of director-centred teamwork has been taken as guidelines in the tradition of dubbing in China where the dubbing director is on the equal footing with the film director in both theory and practice as indicated in the above schema.

2.5.2 Summary

In summary, research on dubbing in China lags behind work in this area by scholars and dubbing experts in other countries. Compared with the progress in film translation studies in the world, the meagre findings reflect lack of scholars' interest and vision, as well as limitations in mode of thinking and exchange of information in the circle of film translation in this country. However, this further observation of the state of the art has led to some phenomena that can be taken up as original topics worth investigating⁵¹.

This brief survey with respect to English-Chinese film translation in China is by no means exhaustive; but a word of conclusion can be drawn with certainty that research in this area is weak and needs insight provided by new theories and practices in translation studies, linguistics and other related disciplines.

2.6 Need for Theoretical Input in FTD

This survey in quest of the relevant findings and methodologies has shown:

- (a) that film dialogue translation as a subject for systematic study is still in its infancy; as a subdivision of Translation Studies yet to be broadened, it demands a well-founded theoretical framework and a joint effort on a multilingual scale by researchers in translation studies, linguistics, discourse analysis, media studies and socio-semiotics.
- (b) Although film translation studies has made pleasing progress in recent years, the trend in the direction of linguistics-informed research has not become predominant. There is urgent need for theoretical input into the studies of FDT in general and dubbing and subtitling in particular.
- (c) There are many major issues remaining to be addressed, general or specific ones to these two domains of film translation. Common to both, for

example, is one of such topics yet to be perused as regards the 'translation' of the extralinguistic meanings of film dialogue in SL conveyed by prosodic means, such as rhythm, pause, stress, duration and intonation patterns. Unfortunately, from the literature review of this chapter, we can conclude that topics in film translation studies are mostly specific to dubbing and subtitling genres which are mutually-exclusive.

(d) Conditioned by film's multidisciplinary properties, translation of film dialogue can be studied in different perspectives based on the perception of its nature and the purpose of a study. Different approaches to FDT involve different research questions, methodologies and emphases in providing insight into this field. The following table shows how film dialogue translation has been approached in different purpose-driven contexts, each of which is more based on one single discipline than set on a polysystematic footing.

Nature of the Study	Disciplinary Affiliation, Theoretical Underpinning and Basic Approach	Key Concepts and Issues Concerned
<i>Dub-sub debate</i>	film translation practitioners/producers; TS, media studies; descriptive, persuasive, prescriptive	dub/sub supremacy, audience preference survey, norms of choice of mode
<i>A method of FDT</i>	film translators/ subtitlers/ producers; TS, linguistics, discourse analysis; empirical, descriptive	constraints, problems, strategies, technical procedures, etc. particular to the mode of FDT in question

<i>A type of translation</i>	FDT theorists, linguists; text typology, TS, genre studies; descriptive, theoretical	place of FDT in TS, linguistic characteristics of dubbing and/or subtitling, translation-interpretation dichotomy, genre crossover between spoken and written language
<i>Audiovisual translation for the media</i>	media translation theorists and practitioners, linguists, corporate R & Dialogue; Media Studies, TS, linguistics, communication studies, media semiotics; empirical, theoretical, descriptive, prescriptive	language use in the media, TS issues (process and product), mass culture issues (audience needs, running time, ephemerality), multi-media factors, new technologies, quality assessment, norms, international standards
<i>Spoken language Translation</i>	cognitive/ computational linguists, translation theorists and practitioners, media IT professionals; Spoken and written language, TS, NLP, MT; descriptive, empirical, theoretical	applications of and implications for general SLT skills and theories: translating oral language characteristics, prosody, segmentation, simultaneity and idiomaticity in interpretation, human-machine dialogue
<i>Dramatic Dialogue Translation</i>	literary stylistics, Conversation analysis, Pragmatics, TS, performing arts, film studies aesthetics, descriptive, empirical	performability, artistic re-creation, colloquialism, illusion, TL audience perception/ response, cultural-specific translation problems, TE, free-literal translation continuum
<i>A university discipline</i>	teachers of translation/linguistics/media studies, film translators; descriptive, prescriptive	curriculum developing, training process and methodology, nature and technicalities of the subject, translation skills, TS theory-building
<i>A commercial product</i>	professional dubbers/ subtitlers, business companies; projects for advertisement, handbook, manual. practical, prescriptive	technical aspects of dubbing/ subtitling/ voice-over; new technologies, procedural direction; quality assurance, lip-sync techniques for dubbing, computerized typographics for subtitling, economic considerations

Table 2

- IT - *information technology* • MT - *machine translation* • NLP - *natural language processing*
- SLT - *spoken language translation* • TE - *translation equivalence*

**Film Dialogue Translation
as Different Subject Matter Derived from Its Interdisciplinary Complexities**

The classification above is not complete and the distinction of these diverse research streams can never be clear-cut. They are meant only to represent the general division of the existing and potential orientations in FDT studies.

To build up theoretical models for film dialogue translation process and quality evaluation through analysing film texts representing two distant, even

contrasting cultures, this study needs to draw on the discoveries and achievements in these fields, which are to be integrated and hinged on the increasingly influential principles of spoken language translation and natural language processing in the information flow perspective.

Chapter 2

NOTES

1. See Dijk 1985a, 1985b; Thomas & Evans 1990.
2. With regard to the study of film dialogue, what Zhou Dianfu, a prestigious Chinese phonetician, concluded one and a half decades ago still holds true: "...linguists, too, never included it in their field of research, nor do they accept it as a future project. As a matter of fact, the study of language in Chinese films seems to be nobody's business." (Zhou Dianfu 1982:32)
3. For example, Korpimies 1983; Short 1981, 1989a, 1989b, 1990, 1994; Ryan 1988; Carter & Simpson 1989; Yang 1989, 1991; Leech 1992 and Tannen 1989, 1994.
4. However, there is no agreement on the scope and categories of description required for an adequate account of a particular language genre. An object of stylistic analysis can be tackled from different angles for different purposes.
5. This is an update of the article of the same title by the same authors published in *Semiotica* 1984, 3-4, pp. 323-346.
6. **Discourse analysis**, an ambiguous umbrella term which has become less controversial into the 90s (see Schiffrin 1994), can be simply defined as an interdisciplinary heading covering a range of branches of linguistic inquiry into the use of language by focusing on both text and context. The

main approaches include pragmatics, speech act theory, conversation analysis, the ethnography of communication, and variational analysis. In widened perspectives, the praxis of discourse analysis extends to areas focusing on politeness phenomena, deixis of power and solidarity, relevance theory and interactional sociolinguistics. The merge of discourse analysis and literature has yielded integrated specialties such as *literary pragmatics* and *discourse stylistics* (see Asher 1994).

7. See Melrose 1994:52-53.

8. Here a *continuity script*, as distinguished from a *shooting script*, is being referred to.

9. Specific devices that reveal each of the four features described by Chafe are listed as follows.

Involvement, according to Chafe, is created by these devices:

- 1) A more personal quality; first person references;
- 2) Speakers' mental processes (e.g. 'I think');
- 3) Monitoring information flow (e.g. rising intonation, pauses, requests for back-channel responses);
- 4) Emphatic particles (e.g. 'just', 'really');
- 5) Fuzziness, vagueness, hedges;
- 6) Direct quotes.

Fragmentation is reflected by such colloquial features:

- 1) Co-ordinating conjunctions;
- 2) Afterthoughts;

-
- 3) Repetitions;
 - 4) False starts.

Integration, as Chafe describes it, is achieved in writing by:

- 1) Nominalizations;
- 2) Participles;
- 3) Attributive adjectives;
- 4) Conjoined phrases and series of noun/verb phrases;
- 5) Sequences of prepositional phrases;
- 6) Relative clauses;
- 7) Introductory phrases (e.g. 'In view of this');
- 8) Adverbial conjunctions.

The main devices of *detachment* are:

- 1) Passives;
- 2) Non-native subject;
- 3) Precision;
- 4) Indirect quotations.

10. On speaking and writing with *involvement*, Tannen (1989) sums up that dialogue as literary discourse is related to other aspects of language that create involvement "by which listeners and speakers collaborate in imagining and participating in similar worlds." (id.:173)

11. Examples ascribed to these four features are: preference for deictic modifiers ('this guy'); avoidance of relative clauses; repetition of phonemes and similar syntactic constructions; Tendency to begin narrative in past tense and switch to the present; frequent self-repairs.

12. This work is a revised version in English of a German monograph published in 1985.

13. For a summary review of the latter, see 2.3 of this thesis.

14. After Rose 1981.

15. In the case of creating a modern translated version of a classical work, a free translation comes the closest to adaptation by which even the setting and the contemporaneity of language is changed to a different culture and period from those of the original.

16. Also called *Chinese Opera* (Guo'Ju`) outside the mainland China.

17. The successful hit of the Beijing opera *Phoenix* in English performed by the Drama Ensemble of Hawaii University was exalted after its premiere in Beijing in July 1986. It is widely acknowledged that the English translation preserves the original rhythm, meaning, idiomaticity, humour and other allusions so faithfully that it is an outstanding example in theatre translation between Eastern and Western cultures.

18. This third factor that contributes to the speech running-time is my own addition.

19. The finality of the original drama text is also due to the relative static stage setting, the contained actions of the characters and the sparse and unchanging environment, compared with film's

constantly shifting setting and unpredictable factors, such as location exigencies, actor's freedom of improvisation, editing, studio approval, over-run budget and amendments on preview responses, which result in a wide discrepancy between the spoken lines in the shooting script and what is actually said and recorded in the continuity script.

20. "It is obvious that....translation [for dubbing] errors are bound to occur,..... It is equally obvious that people who may be able to spend more time on these questions - such as applied linguists at universities - will then discover such errors and make cynical remarks about them." (Herbst 1991:158).

21. "Subtitling ... only now is ... beginning to materialize on the fringe of translation studies" (Gottlieb 1991:161) and "...little theory has yet been developed in this field ..." (ibid.:169)

22. Abbreviation for the Centre of Translation Studies, University of Copenhagen, Denmark.

23. Abbreviation for the European Broadcast Union.

24. Abbreviation for the European Institute for the Media, Manchester, UK.

25. Abbreviation for the Fédération Internationale des Traducteurs.

26. Abbreviation for the Centre for Translation and Interpreting, University of Turku, Finland.

27. From the abstract of MSc Dissertation
"Translation Theory and Film/Screen Translation: An
Evaluation Overview" (1996) by Fotios Karamitroglou
submitted to the University of Manchester Institute
of Science and Technology,
[http://www.geocities.com/CollegePark/Library/7917/M
Sc_abstract.html](http://www.geocities.com/CollegePark/Library/7917/MSc_abstract.html).

28. According to the abstract of PhD thesis "Towards
a Methodology for the Investigation of Norms in
Audiovisual Translation: the Choice Between
Subtitling and Revoicing in Greece" (1998) by
Fotios Karamitroglou submitted to the University of
Manchester Institute of Science and Technology,
[http://www.geocities.com/CollegePark/Library/7917/P
hD_abstract.html](http://www.geocities.com/CollegePark/Library/7917/PhD_abstract.html).

29. For instance, whether an animated film should be
dubbed or "subbed" as its more appropriate foreign-
language version is still an unsettled heated issue
among audiences around world (see EX 1998).

30. This refers mainly to most of the existing
literature on film translation since the 80s.

31. Compare "He LOVES you" with "Aber er liebt dich
doch".

32. In Paquin 1998b, with respect to phonetic
synchronism, the word *bilabial* occurs 11 times.

33. This fact is also reflected in Helene Reid's
admission that she is "on extremely thin ice" in
delivering one of her many contributions to the TS

literature on subtitling at the beginning of this decade, because, in her own words, "... just as many people, including perhaps myself, would say that subtitle translating is such a specific form of language conversion that it has stepped outside the category of translation... However, since there is no such thing as straightforward translating anyway, ... let us .. treat subtitling as translation for the time being" (Reid 1990:97).

34. The total loss of verbal information in this film translation is smaller than 16%. The conclusion of this pilot study is based on the instances of application of each type of strategy to the verbal segments calculated by number and frequency.

35. Spoken language translation.

36. China has a dubbing history of half a century (1948-1998). Unfortunately, research in film translation is still in its infancy, if not in embryo. The status quo was confirmed by investigations other than literature search, for instance, from the consensus of Assoc. Prof. YAO Jirong, Prof. LI Yashu and Assoc. Prof. SHI Linan, the leaders of the two delegations to the 14th FIT World Congress, representing All-China Translators' Association (Yao) and the Science-technology Translators' Association of the Chinese Academy of Sciences (Li and Shi) in Melbourne, that studies in film translation in China had been "unheard-of" (quote from the memo of the interview of them by Jian Li on 14th Feb. 1996).

37. Efforts to invoke research in spoken language and stylistics of drama are represented by the 'solo' publications of Chen (1984, 1986) and Yang (1989, 1991) respectively.

38. Although surtitling the dialogue of a stage play for foreign audiences is not a recent event, drama translation in its real sense of the term was first performed in 1995 by the Chinese Central Experimental Drama Theatre when they presented their drama *Zhuangzhou Tests His Wife* in English. This was hailed as "the first ever drama [sic] not staged in their mother tongue by a Chinese professional troupe in more than the 80-year history of Chinese drama" (p. 27, *Beijing Review* July 17-23, 1995). Also, as a telltale reflection of dearth of drama translation in China, the following quotation from the same news weekly is worth noticing:

The fact that Chinese artists are able to use a foreign language in acting shows that they are brave and creative in their dramatic experiments. This was a good opportunity for foreign audiences to understand what is on stage and for English-language learners to improve their listening comprehension". (p.28)

39. I have collected a number of such unofficial publications relevant to dubbing since my fieldwork in China (Feb. 1994). Most of these articles impart experiences in relation to the artistic aspect of dubbing performance rather than exploring issues or problems in translating for dubbing.

40. See the *Film* volume, *Zhongguo Da Baikequanshu* (China Encyclopaedia, 1991), pp.210-211.

41. See *Xinzhongguo Dianyingde Yaolan* (The Cradle of New China's Cinema, by Hu Chang, 1986), p. 252.

42. See the *Entertainment Page* of *Guangzhou Daily*, 26 March 1997.

43. That is, the China Film Import & Export Corporation, which was set up at the end of 1979. Its predecessor was the Import & Export Department of the China Film Distribution Corporation. Being the only government organization of the whole country, CFIEC is responsible for purchasing and distributing foreign films. Each year it allocates dubbing quotas to the specialist dubbing studios. It also handles all overseas sales of Chinese movies. The corporation is divided into five major departments, each in charge of I/E business with a separate region: Asia, Mid-East, Africa, Europe or America. Besides, there is a translation section and a subtitling workshop under its administration. It also has an agent office in Hong Kong.

44. See "The 1994 Distribution Quota of Dubbing for Feature Films and Animated Films" in *Dianying Shichang* (Cinema Market, a monthly journal of the China Film Import & Export Corporation), 2/94, p.30.

45. This 'qualifying' step is especially necessary for those dubbing directors who have little or no knowledge of the target language; as the truth of the matter, very few of the Chinese directors are competent bilinguals.

46. 'Triply', because the translator has to not only overcome the translational constraints, i.e. the real-time confinement within which words must match the visual without room for footnotes, but also the external constraints largely due to the system, viz., the extremely tight deadline with no incentive and the censorship of obscene or 'culturally-contaminated' words in his translation.

47. Reference to such discouraging conditions of Chinese dubbing translators here (more typically for those working for TV stations) are based on the six-month (February - July, 1994) field survey involving film dubbing studios and TV broadcasting stations in a number of China's major cities, including Guangzhou, Shenzhen, Wuhan, Beijing and Shanghai, as part of this project.

48. See Note 12.

49. This is the biannual national seminar held concurrently together with the First Congress of the China Association of Radio Broadcasting, Film and Television in Nanjing on 14-21, 1993.

50. There is no reference made to the background or additional information in regard to these four principles.

51. A number of such issues will be outlined in Chapter 7 for further research.

Chapter 3

THE INFORMATION FLOW PERSPECTIVE

3.1 Introduction

Film translation is a special type of translational activity in that the linear presentation of the original dialogue into the target text in either the spoken form or the written words must match the visual dimension of the film medium in terms of communicative functions of the speech and the non-verbal language. Aiming at achieving the original effect of the picture and sound working in harmony, the dialogue translator has to make decisions on translation goals and strategies as regards:

- 1) how the SL dialogue should be segmented into working units of translation;
- 2) in what order the content of the identified information should be arranged to keep it in conformity with the interpretative arrangement, i.e., communicative dynamism or CD (first introduced by Firbas 1956; definition see 3.2.2.1) and/or prosodic features (pitch, pause, stress etc.), of the original utterance;
- 3) what information in the original dialogue, given the temporal and spatial constraints,

- must be kept (following the linguistic patterns of SL or incorporating adjustment to meet TL requirements), what expanded or reduced, and what replaced with a comparable concept in the target culture or left out altogether, at a particular grammatical rank;
- 4) in the case of subtitling, what levels of equivalence to the original dialogue should be realised through this phono-graphic transfer from oral to written language.

A basic concern of the present study so far has been to decide which theoretical tools available in linguistics have the potential to provide the most powerful solutions to the particular problems facing the film translator. In spite of the fact that translation studies in recent years have directed growing attention to the Prague model of theme/rheme distinction and the Hallidayan systemic-functional approach (see Newmark 1988, 1991; Hatim 1990; Baker 1992), awareness of the functionalist approach in general and information flow in particular in the circle of film translation has so far remained weak. Kovačić (1995) claims, "Functional models seem to work well in bridging the gap between linguistics proper and other approaches to studying language activities,

the most pertinentamong them being discourse analysis and conversation analysis."(p.2) In her article on subtitling strategies (ibid.) and her other works, she has applied the model of metafunctions developed by Halliday (1985, 1989) to her studies on subtitling with satisfying results to the effect that the ideational-(inter)personal-textual model facilitates the decision-making on "a flexible hierarchy of priorities" in the process of subtitling(ibid.). Brondeel (1994:29) found that transferring CD, as reflected in the prosody of the original film dialogue, into subtitles can earn the target text an "added" communicative value and therefore achieve greater effectiveness in terms of professional approval. This discovery would have found theoretical backup in what Lyons refers to as achieving "the same communicative effect" (1995:156). Also on the functions of intonation and stress in communication, Thomas Herbst's important discovery with respect to the necessity of nucleus-sync in dubbing (Herbst 1987:22; 1991:160) has pointed out an intricate relationship between stressed syllables and the corresponding body language, what Mason calls the "voice-matching" constraints (1994:1067), which has come very close to the theory on the prosodic prominence of new information in the information flow

perspective. Unfortunately, this crucial demand on dubbing has not been sufficiently emphasized nor its significance further explored.

Apart from the above scanty evidence of the applicability of functional models to film translation, the decision to turn to this stream of linguistics for theoretical input and practical solutions to both dubbing and subtitling problems is based on a number of attested assumptions. The first and most important of these is that film dialogue translation must include interpreting the salient features of intonation embedded in SL film dialogue into the corresponding form of the TL representation, such as the pause patterns, stress, tone, duration and speed, because they affect significantly the production and perception of information in film dialogue.

The next deliberation is that the analysis of film dialogue and its translation in the perspective of the dubbing-subtitling dichotomy corresponds to the spoken-written language division in the way that each genre can be systematically described and functionally compared and related to each other in their different contexts. In respect to both these two points of my concern, film dialogue translation

will stand to benefit more from the findings and instruments with respect to intonation and meaning contributed by functional linguistics than from what has been yielded by other schools of linguistics that I enumerated in the previous chapter. For example, studies in the prosody of spoken language and that of written language can be related closely to the same aspect of spoken and written modes of film translation.

My third conviction with regard to the functionalist tradition in approaching the present study is that it offers a balanced approach to textual analysis: its principles attach due importance to the cognitive and social functions of language and enable a text to be analysed from the macro to the micro level, or vice versa. Viewed in these dimensions, film dialogue translation through the process of transfer and synthesis can achieve an overall equivalence in TL in terms of semantic, stylistic, pragmatic and prosodic correspondence.

To hit all these targets in a unified and coherent process, the functional theory on information flow seems to be an ideal weapon. It will be reasoned in this chapter that the functionalist approach to information flow has much more to offer for film

dialogue translation than other approaches which have commonly been explored in film translation, and that a translation approach based on this theory which takes the intonation unit as UT serves as a promising working model for dubbing both as process and product, at least it is the most appropriate answer to the existing problematic English-to-Chinese film dialogue translation.

Research on information flow is copious and diverse. I will in this chapter review the main components of this theory, focusing primarily on three leading trends in this area of research: viz., FSP¹, the Hallidayan approach to information structure and Chafe's functional-cognitive model². What follows will only reflect some major contributions to this area of research, especially the principles of these schools of thought in approaching spoken discourse for understanding the information flow by means of determining the unit of information against a context of the internal structure of discourse. Then I will concentrate on the effects of information flow on the prosody and word order in written as well as spoken discourse, highlighting the important role of the intonation unit in segmenting and controlling the movement of ideas in a dialogic interaction. As feedback to

different models under review, the relevance of these findings to English-Chinese film translation will be discussed. I will conclude this chapter by emphasizing the applicability of the analytical system developed by Chafe (1994) to film dialogue translation.

3.2 Information Flow

As will be detailed below, the term "information flow" (henceforth, interchangeably with **IF**) is attributed to the Prague linguists as the central thesis of FSP. It has been widely adopted and substantiated in the literature by linguists of the functional tradition. It is used to distinguish between "old" and "new" information in speaker's and listener's ideas in the production and perception of the language in use. *Information* in this context equates ideational content, whereas the ongoing change in phase of cognitive activities in interlocutors' minds through time is likened most appropriately to the metaphoric word *Flow*. Information flow influences and interacts with such linguistic features as prosody, word order, verbal structure and pronominalization in both spoken and written discourse.

Before theories of information flow are brought into the foreground, a brief review of the historical development of functional linguistics is necessary.

3.2.1 Overview

The Functionalist-Formalist paradigm has been widely recognized as comprising two distinct linguistic research schools since the mid-70s and it was around that time that what is labelled as the functional approach began to be common. Within the functionalist camp a number of different approaches exist. The basic tenet shared by all of them is that language is an instrument of social interaction and that its cognitive and social functions determine its structures and the grammatical systems. Functional analyses are concerned with the relationship between form and function and the way in which the individual as "a social man" (Halliday 1974) learns and uses language in the context of social communication. The concept of functionalism in linguistics is closely linked with the Prague School of Linguistics, the early precursor of the American functionalism. Vilem Mathesius' work in 1930, which marks the beginning of the Prague tradition, has been followed and developed by many, especially active among them

being Frantisek Danes, Josef Vachek and other Czech linguists. Further development and expansion of the functional drive in linguistics was not only found in the Prague School, or in the influential functional principles illustrated by Bolinger (1977, 1979) in his description of the grammar of Spanish and English, and his studies in intonation and its discourse functions (e.g., Bolinger 1986, 1989); but also in other strands of functionalism such as Halliday (e.g., 1978) and Dik (1978, 1985), with their respective formulation of a more systematic functional grammar, and in the works and the papers of Hopper 1979, Givon 1979a, Chafe 1976, 1980, 1987 and others. During the past two decades or so, quite a number of studies (e.g. Firbas 1974, 1987; Halliday 1985-1994; Chafe 1992a, 1994; Givon 1979b, 1984; Dik 1989) have reintroduced the key concepts and theories of Prague School functionalism into mainstream linguistics.

The greatest contribution of the Prague School to the linguistic world is perhaps the awareness of the communicative goals of an interaction, the so-called functionalist awareness, which is highlighted in an analytical system for the study of the informational organization of the sentence,

what is collectively referred to as Functional Sentence Perspective (FSP).

Much to Mathesius' credit for his pioneering work, two aspects in FSP have been recognised and established: (a) the division of the content structure of the sentence and, (b) its dependency on the context. These two different sets of values are divergently developed into two important dichotomies, namely, the theme-rheme articulation and the given-new information distinction. The latter was discerned from the point of view of retrievability of information from the sentence and the context in which it occurs, when examining the theme-rheme distinction that was uncovered by Mathesius (for these concepts see 3.2.2.1). He further explored various means of expressing the FSP structure including word order and prosody in texts of different types. These fundamental ideas were followed and refined by other functionalist linguists, particularly Jan Firbas, one of the major exponents of this school, whose work is regarded as being "amongst the most prestigious of the Prague School in this area" (Davidse 1987:65). It is the key notion of various elements of a sentence having varying degrees of CD in their contributions to achieving a communicative goal

that initiated the theory of information flow in linguistics³.

3.2.2 Functional Sentence Perspective

The details of the FSP theory are rather complex and there are several distinct approaches within the Prague school itself. As noted above, a recent trend representing the advances of this school may be seen in the effort of Firbas, who, from the late 1950s, devoted most of his studies to investigating the function of communicative dynamism and the interplay of four FSP factors, viz., linearity (order of elements), semantics, context and intonation, and their interaction with communicative function. A predominant concern of this trend is represented by the basic notion of functional sentence perspective, which lies in the positioning of information-bearing sentential units in terms of their theme-rheme arrangement or what is known as communicative dynamism.

3.2.2.1 Communicative Dynamism

According to the FSP theory, within the structure of the sentence, an order predominates in which a *theme*, "what the sentence is about", precedes a *rheme*, "what is said about it". The element linking theme to rheme is labelled *transition*,

which refers mainly to the temporal and modal exponents of the verb (Firbas 1992). Thus in the sentence

(1) *It should be clear.*

Theme Transition Rheme

It would be theme, while *clear* would be rheme; *should be* is the transitional element linking theme to rheme. According to FSP, such thematic structure which involves placing theme before rheme normally matches the linear ordering of syntactic elements in a sentence in SVO languages (e.g., typically in English, the subject of a sentence tends to be thematic and the predicate rhematic).

The relative importance of theme, transition and rheme with respect to their different roles in conveying information and pushing the communication forward is covered by the term **communicative dynamism**. This notion is defined as "the relative extent to which a linguistic element contributes towards the further development of the communication" (Firbas 1992:8). In practice, CD is used to measure the information flow in a sentence in terms of the relative contributions of these elements in each of the tripartite divisions.

Within a sentence, the theme is the element that is considered "foundation-laying" and "context-dependent" (ibid.) and consequently carries the lowest degree of CD. In the "core of the message" or the "non-theme" (id.), i.e., transitional and rhematic elements, the former is communicatively more dynamic than thematic elements but less important, with respect to the amount of unknown information it carries, than the latter. The rheme, normally being "context-independent" (id.), bears the highest degree of CD. That is "the element conveying the piece of information towards which the communication is perspectived." (ib. p.73). Thus in sentence (1) above, the sentential elements appear in order of increasing communicative dynamism, with clear exhibiting the highest degree of CD.

As mentioned earlier in this chapter, from the theme/rheme articulation, a further distinction was drawn between given information - which represents the common ground between speaker and hearer and, new information - what the speaker wishes to make known to hearer. The fact that given is often thematic and rheme often coincides with new obscures to some extent the distinction between the two different types of structure in FSP, as the

thematic and information structures are by and large conflated in the description of CD (see "the contextual factor" in 3.2.2.2). This makes the position of FSP on these two dichotomous sets distinctly different from Halliday's approach to information structure(see 3.2.3).

3.2.2.2 Interacting Factors in FSP

Firbas' version of FSP depends on and centres around the notion of CD. The distribution and assessment of CD in a sentence is determined by four factors: linear order, semantics, context and intonation. The last factor applies to spoken language only.

It was originally understood in FSP ("the FSP linearity principle", see p.118, *ibid.*) that normally CD gradually rises in the straight linear order from the beginning to the end of a sentence, hence theme normally preceding rheme. However, Firbas' work also acknowledges that in other circumstances this syntactic factor (linear modification) is upset by semantic structure and context, and, in spoken discourse, intonation. CD is thus achieved through the interplay of these four factors.

The semantic factor involves the role played by the semantic content of the verb and its semantic relations. The verb can be used either for presentation of a phenomenon or for expressing a quality. These two sets of semantic functions are called 'the presentation scale' and 'the quality scale' (p.67, *ibid.*). The contextual factor relates to information retrievability/irretrievability. Retrievable information (given) is context-dependent, whereas irretrievable information is new and independent of the immediately relevant situational context. The point in this description is that context-independent information carries greater CD than context-dependent information. These factors operate either in the same direction as or override the linear word ordering of CD.

The intonational factor concerns spoken discourse only. The central theme in this part of Firbas' FSP theory is whether there is correspondence between the distribution of CD, as determined by the non-prosodic factors (the first three listed above), and the distribution of prosodic prominence (PP). The conclusion is: sometimes there is perfect correspondence. In the case of sentence (1) above, the rhematic element *clear* receives the greatest PP as well as CD. The three unstressed

words *It, should, and be* show a gradual rise in PP, corresponding to the increasing CD values in the linear arrangement of these elements. But the degree of CD does not always correspond perfectly to that of PP. A variety of such situations are then discussed in Chapter 8 of Firbas 1992. This shows that all these factors are present in any language, but their interplay may vary in different languages.

3.2.2.3 FSP in Translation Studies

The early influence of the Prague functional linguistics on the study of translation can be traced back to the 1930s, but not until 30 years later did it become evident in Mounin 1963 with his communicative approach to translation which concerns the underlying functions of language (See Kelly 1979:passim). However, more confirmed efforts to relate the key concepts of FSP immediately to topics for translation studies have only been seen in recent years (e.g., Newmark 1988, 1991; Hatim & Mason 1990; Baker 1992), in which thematization, born of the theme-rheme distinction in the CD perspective, is held to be a basic aspect of textuality that operates as a major system to support discourse cohesion (Hatim & Mason 1990:212). Firbas' version of information flow has

been welcome in the literature of translation studies (see also Hatim: 1984, 1987) for the way in which that it highlights the communicative goals of an interaction that cause the structure of a sentence to thematize in different perspectives; therefore, it "indicates the importance of correctly preserving emphasis in translation" (Newmark 1988:61) and "suggests that translating between languages with different priorities and different syntactic restrictions necessarily involves a great deal of skewing of patterns of information flow" (Baker 1992:167).

The other useful concept of the FSP adopted in translation is "the context of experience" (Newmark 1991:96), which is understood for translation purposes as the "shared assumptions" (Hatim & Mason 1990:216) between writer (speaker) and readership (listener). In translation, unlike the old information (theme), which can be paraphrased in TL since it is retrievable from the context; the new (the rheme), which is relatively context-independent, needs to be translated precisely. The value of the above-mentioned concepts can be reflected in the observation that "[v]ery often, vague feelings of dissatisfaction with a

translation are ascribable to subtle shifts in the saliency and recoverability of information" (ibid.).

A further aspect that reveals the relevance of FSP to translation is perhaps the contrastive method it has adopted in the analysis of multilingual textual examples. Firbas (1992:13) stresses the importance of this approach: "The contrastive method proves to be a useful heuristic tool capable of throwing light on the characteristic features of the languages contrasted." In practice, his contrastive findings have contributed to the understanding of the translation process; at least it has proved to be helpful in demonstrating how decisions are made in finding textual equivalence between the original text and the translations in different languages (e.g., id.:passim).

As a starting point in discussions of translation problems and strategies in the light of the interaction between different linguistic and contextual factors with the thematic structure of a sentence and its emphasis at the informational level, FSP deserves its established place in the awareness of a translator who is to weigh the functional purposes of ST against the different phonological, lexicogrammatical and syntactic

tendencies in TL and employ accordingly its various linguistic devices in order to transfer the information flow properly and effectively. Firbas' FSP system itself has, however, obvious limitations (see the following in this chapter) and, from a pragmatic point of view, it can offer at its best some basic principles to translation practices and, in the case of translating spoken genre, the applicability problems seem to be unresolvable.

3.2.2.4 FSP in Spoken Communication and Its Relevance to Film Translation

As far as Firbas' theories of CD in spoken discourse (See esp. 1992) are concerned, little attention has been given by linguists in translation to this important aspect of FSP. As early as in Firbas 1985, the problem of the interrelations between FSP, prosody and emotiveness was initially addressed and since then the place of intonation in expressing and distributing various degrees of CD over the sentence has been viewed in a new perspective. The key concerns of these observations and findings, as introduced in 3.3.1.2, may serve as a sound basis for studying information flow in spoken discourse. However, in analysing conversations and planned spoken discourse such as film dialogue and its

translation, Firbas' model does not seem to be readily applicable due to its shortcomings on several accounts.

First of all, the definition of CD needs to specify how the degrees of the relative contributions of sentence elements to the communicative goal can be measured; unless this is done, it is necessary to question its use as an overriding notion to govern all the involved factors in determining the information flow of a sentence. It seems that, in practice, CD tends to be put in oblivion by other watchwords of immediate concern to the translator such as old/new knowledge, theme/focus, context-free/dependent information, unit of information, saliency, emphasis, underlying message, etc. At least, the relation of CD to these functions needs to be clarified. Secondly, FSP purportedly limits itself to the boundaries of individual sentences, although important consideration is given to the context within which a sentence occurs. In an interactional spoken discourse, however, sentences are "independent of cognitive constraints". "There is nothing that holds them to a particular size, as there is for intonation units" (Chafe 1987:46) and therefore they are not the natural discourse unit of information. Thirdly, from a functional-

sociolinguistic point of view, information flow is conditioned primarily by conversation goals initiated and oriented through a turn-taking mechanism in which intonation plays a vital role. However, Firbas' CD and PP theory does not touch on how intonation functions in the turn-taking mechanism (See Sacks et al. 1974; Geluykens 1992). Lastly, it has been pointed out that Firbas' notions of FSP "do not extend to the psychological aspect of communication" (Baker 1992:162) but only rely on intuitive evidence; whereas the introspective dimension in spoken communication is too important to be overlooked (see Chafe 1987, 1994).

In spite of its limitations, the revolutionary step Firbas took to advance the earlier FSP theories by examining conversational discourse (Firbas 1992: Part II) has opened up a very promising testing ground for understanding and controlling information flow in the CD perspective. This fundamental framework, though not overtly defined, has nevertheless thrown new light on the importance of correctly highlighting salient information cross-linguistically in translation.

FSP since Jan Firbas, has developed into a very composite system. As Baker 1992 pointed out, "[t]he analysis of clause elements in terms of FSP is clearly a complex business. It is not as easy to apply or follow as Halliday's system." (p.164)

3.2.3 Halliday's Approach to Information Flow

Both being functional-structuralist by nature, Hallidayan linguistics and the Prague School share much in common in that both are primarily concerned with the external functions in relation to the internal organization the language system serves and its role in human communication, so that they build their descriptions of language, from the macro components to basic elements of structure, on a functional basis. Halliday, however, is characteristically more social in orientation; he has created a well-developed grammatical system in social and pragmatic dimensions, as well as within the context of semantics, thus incorporating language, situation and culture into a hierarchical entity.

As noted earlier, Firbas (id.), in investigating the communicative process in the FSP, differs from the traditional single-system grammatical analysis in that the thematic and rhematic aspects of sentence

structures are considered in terms of known/new information they contain. Influenced by Firbas' FSP, Halliday, attaches great importance to the distribution of theme-rheme articulation; but, he separates thematic and information structures in his treatment of IF within, but not restricted to, the level of the clause. To him, there are two distinct layers of structure, rather than one, to represent clause as message. Discourse information in Halliday's system is more pragmatically processed in this "separating" approach to Theme as contrasted to Firbas' "combining" point of view (see 3.2.3.3).

3.2 3.1 The Clause

Hallidayan linguistics is spearheaded by its systemic-functional grammar (SFG), which is sometimes identified with Halliday's clause grammar because of the centralised reference to the key concept "clause" in most of his works on SFG, especially in Halliday 1985 and 1994 (henceforth, IFG)⁴. In a sense, the clause structure has been the grammatical base on which the Hallidayan functionalism including IF theories is built. Just as the sentence in FSP serves as "a field of relations" and "a distributional field of prosodic prominence" (Firbas 1992:p.15), the role of the clause in SFG can be seen as the hub of all

relations between constituents of grammar, writing, speech and information systems. The adherence to the clause as the fundamental structural unit in SFG is typically evidenced in the organization of *IFG*: Part 1 entitled "The Clause", consisting of three key chapters on clause as message, exchange and representation respectively and, Part 2 "Above, Below and Beyond the Clause" including also "Beside" and "Around" the clause.

The conceptual intricacies of the scale of rank for SFG are presented in *IFG*, where definitions, distinctions and correlations of, and between, constituents in the four different dimensions, viz., grammatical, orthographic, phonological and informational, are frequently reiterated. For the purpose of our later focus of interest in seeking the proper unit of film translation, we may, by interpreting the author, appreciate the rigorousness of the systemic stratification in simplified terms. As shown in Figure 8, comparable concepts are linked up between the systemic options of the clausal units and the corresponding layers of the structural and informational realizations. Here correspondences of units are shown primarily at the level of clause structure and what is immediately above and below that level. "This is

because the mode of interpretation adopted here is a functional one, ...and ...it is the larger units that function more directly in the realization of higher-level patterns" (IFG:p.19). Since there is no direct relation between the functional concepts in the clause system and the formal units of segmentation in speech and writing, what is summed up here is just meant to elucidate the ingenious choice of the notion 'clause' as the starting point towards examining the informational organization of language in actual spoken and written communications.

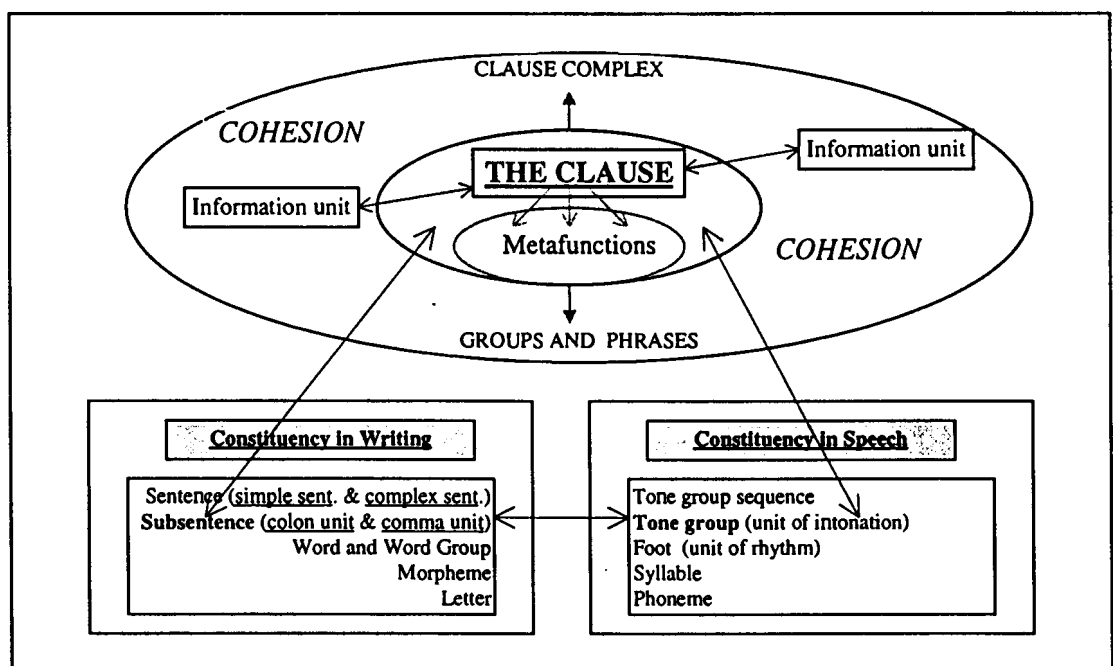

Figure 8

Approximate Correspondence of Layers of Structure Between the Clause Framework and the Linguistic Realizations (According to Halliday 1994)

According to Halliday, "in functional grammar... a clause is the same unit whether it is functioning alone (as a simple sentence) or as part of a clause complex (a compound /complex sentence)"(id.:xxi). In other words, "[a] sentence will be defined, in fact, as a clause complex"(p. 216; for the same point, see also pp. xx, 215, 309); whereas a clause coincides with a simple sentence (pp.180, 216) or a "sub-sentence", whether it is a unit separated by a colon or semicolon or a unit separated by a comma (pp.4-5, 10). "Beside the clause"(p.292), the *tone group*, can be seen as the phonological realization comparable to the clause as a grammatical constituent, although Halliday does not make this point explicit(pp.16, 19). This is because, in his words, "the tone group serves to organize discourse into INFORMATION UNIT"(p.292) and "[o]ne tone group expresses one unit of information"(p.39); but the latter "does not correspond exactly to any unit in the clause grammar". Then he continues, "The nearest grammatical unit is in fact the clause; ... other things being equal, one information unit will be coextensive with one clause"(p.295; see also p.336). Of course, "other things are often not equal"; therefore, "a single clause may be mapped

into two or more information units" or vice versa (p.296). On the other hand, however, Halliday expresses it quite clearly that "[t]he written constituent that derives from the tone group is what we called the 'sub-sentence', marked off by comma or semicolon" (p.10) and, "[t]hese are all interrelated: the sub-sentence in writing ... relates to the tone group in the sound system, and both these relate to a constituent unit in the grammar, the CLAUSE" (p.16). Hence, a tone group corresponds closely to a clause.

We are now in a good position to view the rationale behind the choice of the clause, instead of the sentence, as the key link in a network of systems of relationships in SFG. The sentence, being a constituent of writing, is used "simply to refer to the orthographic unit that is contained between full stops (p.216), although it "does constitute a significant border post" in writing systems (p.xxi). Spoken language, being "a real-time process" by nature (Brazil 1995:12-13), does not fit in with the description by the traditional "sentence grammar". Sentences are qualified merely as "abstract notions" during spoken communication and artificial segments of the "used

speech"(id.:15). The reality that speech is in a constant state of flux gave birth to the approach that it is only the functional increments of which speech is composed that are identified as natural and manageable meaning units for description. "Intonation performs both a direct and indirect service to this sort of chunking... in the same way that syntax does..."(Bolinger 1989:82). In Halliday's system, the melodic unit of speech above the foot, the rhythmic unit, is the tone group. "Melody as a linguistic feature is called INTONATION; so the tone group is the unit of intonation"(p.295). Since it "also functions as the realization of ... a quantum or unit of information in the discourse"(id.), the tone group is the best candidate for anchoring boundaries between the semantic chunks in speech. Thus the place of the tone group has been established as the unit of organization basic to spoken language just as the sentence is the unit basic to written language.

An ideal grammar needs to be able to accommodate all these formal properties of language in an interrelated system to account in full for their functional-informational organizations and semantic choices, transcending, in so doing, the limits of

mode and genre of discourse. This is where Halliday's SFG is intended to come in⁵. To him, a grammar is a purpose-driven, semantics-oriented tool for describing and analysing a piece of language irrespective of "formalised models" of any kinds (Halliday 1964:13; 1994:xix, xxxi). All in all, the clause serves to be the happy medium between writing and speaking for such a "'natural' grammar" (IFG:xvii):

Hence in the analysis of a written text each sentence can be treated as one clause complex, with the 'simple' (one clause) sentence as the limiting case. With a spoken text, we will be able to use the grammar to define and delimit clause complexes, in a way that keeps them as close as possible to the sentences of written English. (p.216)

3.2.3.2 Metafunctions

Three functional configurations are embodied in the structure of a clause. Labelled 'clause as representation', 'clause as exchange' and 'clause as message', these three strands of meaning are identified with the metafunctions', which constitute a focal concept in SFG. Each of these metafunctions relates to a separate dimension, viz., ideational, interpersonal and textual, in the overall meaning of the clause; at the same time,

they associate with each other closely on an equal footing in construing the internal structure of the clause. In fact, these interrelated patterns of meaning operate not only in the clause but throughout the whole of language.

The *ideational* function is to encode our experience of the real or imaginary world. It depends more directly on the grammatical properties of the clause than the other two functions: the *interpersonal* function that encodes speaker attitude and the forms of interaction such as primary speech functions and responses (see *IFG:69*) and, the *textual* function that expresses the relationships between grammatical units and intonational units, respectively, in text with respect to the relevant context. Each of the three dimensions has its own subsystems to interpret its meaning and function from different perspectives and these triplets are all mapped onto each other simultaneously. Table 3 has listed the major components of these ramified systems in the framework of the metafunctions as they are termed and categorized in SFG.

METAFUNCTIONS	IDEATIONAL ← Experiential Logical	INTERPERSONAL ←	TEXTUAL ←
Corresponding Conceptual Categories	Reflective	Active	Relevance
Kinds of Meaning	Representation	Exchange	Message
Status of the Clause	TRANSITIVITY	MOOD	THEME
Semantic Structures	<i>Representational</i>	<i>Interpersonal</i>	<i>Organizational</i>
<i>Choice of Meaning:</i> →			
Systemic Options	Process; Participant; Circumstance	Speech functions (speech role & commodity exchanged)	Thematic structure; Information focus; cohesion
Constituent Structure (Grammatical System)			
<i>Varieties of Subject*:</i> →			
Register Variables	FIELD	TENOR	MODE (GENRE)
Intonation Functions**	Disambiguation; Mor- pho-syntactic marking	Attitude; Illocutiona- ry force; Turn-taking	Information chunking; Thematization; Focus

Table 3

Infrastructure and Correlates of the Metafunctions (According to Halliday 1994)

- * See also Lyons 1977
- ** According to Esser 1987

The concept of metafunctions as general language functions is a macro notion that runs throughout SFG in that it delivers logical mechanisms for explaining the internal makeup of language and, therefore it can be readily related to the functional-semantic paradigms and their relationships in a particular aspect of language as well as language as a whole. An immediate association to bring up is the correlation between these "three more basic functional components" (Malcolm 1991:176) and the register variables of *field*, *tenor* and *mode* evolved in the same semantic system. Ramifications of this system in functional linguistics are numerous. For example, Chafe (1994) uses the

concept to categorize "regulatory intonation units" into subtypes in terms of their discourse marking functions, viz., "interpersonal, textual and cognitive" (p.37). To Esser (1987) these general language functions are "a suitable frame of reference to classify functions of intonation" (p.386; Cf. Table 3).

The consideration of intonation in the framework of basic language functions similar to Halliday's classification, as Esser (id.) observed, was seen in others' works (Lee 1956; Danes 1960; Cruttenden 1970; O'Connor 1973; Brown 1977; Brazil 1980), including Halliday's early theory on intonation. Halliday 1967 proposed a triplet of *tonality*, *tonicity* and *tone* which corresponds to the three metafunctions in terms of *delimitation* (the morpho-phonological segmentation of language unit, which is comparable to ideational function), *focusing* (the prominent syllable in a tone unit, which relates to the textual function) and *modality* (the speech-act functions and attitudinal implications, which pertains the interpersonal functions). Later Halliday replaced the unusual term 'tonality' with the concept *foot* subsumed in the category *rhythm*. This modification is reflected in Halliday 1970 and

it has been used in his account of intonation in his later works ever since.

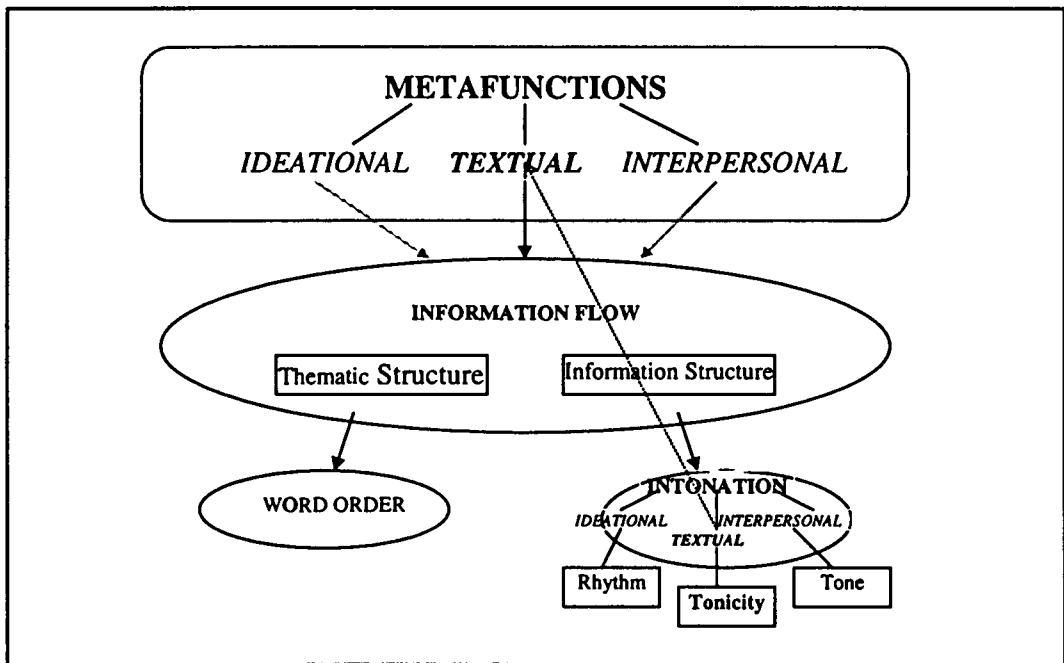

Figure 9

Functions of Intonation as a Subsystem of the Global Functions of Language

The textual function of intonation receives the most weight in its own system and bears direct relevance to the general textual function of language, an area to which Halliday has contributed significantly in recent decades. Of the three areas in his intonation theory, it is tonicity that has been most substantiated with respect to its function performed in the information structure, which is logical and consistent in line with the development of the upper metafunctional division. In other words, this evidences the corollary of the

penetrating operation of the metafunctions in all layers of language. In Halliday's terminology the language function that accounts most for information flow is *textual* and is fulfilled through thematic and information structures, which, in turn, are realized mainly by word order and intonation respectively (see Figure 9).

3.2.3.3 Thematic Structure

As is generally recognized, the influence of the seminal writings of the Prague School since the time of Mathesius may be traced in Halliday's response and approach to the FSP structure and the signalling linguistic devices used in it, including phonological features in respect to language functions (e.g., Mathesius 1937). However, in contrast with the 'combining' approach adopted by the former⁶, who treats the two aspects of the theme (viz., that it is contextually known and it is what the speaker chooses to take as the starting point of an utterance), as comprising the same layer of structure, Halliday insists that the two dichotomies of theme-rheme and given-new need to be contrasted and separated, even though they often coincide. In his view, clause as message is organized in terms of *theme* and *rheme* (from the point of view of the speaker) and *given* and *new*

(from that of the listener) and therefore, it should be analysed in terms of thematic structure and information structure as two essentially different features of discourse organization.

Halliday's Position on Theme

These two approaches lead to fundamentally different criteria for identifying as well as defining the theme. For Halliday, as least in English, theme always occurs at the beginning of the clause regardless of its syntactic status. For Firbas, the theme is the element with the lowest degree of CD and is identified by first distinguishing the degrees of CD in each of the FSP components through assessing all the interacting factors involved. When it comes to defining the theme, Halliday is not content simply to give a repetition of the second layer of meaning in the definition of the theme recognized by the Prague School, i.e., theme as the speaker/writer's point of departure. Rather, he defines it as the point of departure of a message conveyed through a particular unit. "'Theme' is simply the label that we use to suggest what meaning is attached to first position in the clause" (id:53). Meaning is the result of the choice. So it is basically a matter

of thematization through choice of Mood (*IFG:42,47*).

Marked and Unmarked Thematic Structure

The choice of an element of the clause as the theme can be "marked" or "unmarked", depending on the extent of meaning it carries. In a particular language, some elements are typically expected to be in the initial position of a clause, i.e., they are more obligatorily thematic and less meaningful as such a choice than others, so they are unmarked themes. Other elements, when chosen as the theme, have a special status in the thematic structure of the clause, so they represent a "marked" thematic choice. "[S]uch marked themes usually either express some kind of setting for the clause or express a feature of contrast" (*id:48*). The degree of markedness of the theme is therefore closely related to the speaker/writer's intention to bring it to the listener/reader's notice.

According to SFG, different languages, even different genres of discourse within the same language, have different criteria for marked and unmarked thematization. For example, Brown and Yule (1983) find that using place adjuncts as themes is a systematic strategy employed by travel

brochure writers, whereas for detective fiction, an unmarked feature is the constant fronting of the time adverbials. One of the examples given by Halliday is the observation that in everyday conversation the items most often found as the unmarked subject/theme in a declarative clause are personal pronouns, with *I* and *you*, being the most usual forms of theme (IFG:44). This is especially the case in film dialogue which, as a form of dramatic discourse, is basically about "... an *I* addressing a *you*, here and now" (Elam 1980:139).

3.2.3.4 Information Structure

Both Firbas and Halliday take up the problem of the interaction between theme-rheme articulation and the functions of intonation in their respective studies of information flow, but Halliday construes the second phenomenon in a different meaning system. To Halliday, the theme-rheme structure is only one aspect of the clause as message; the other distinction is drawn by him between what is given and what is new in a message. This concerns the information structure as regards what part of the message is recoverable to the hearer and what part is non-recoverable according to the speaker's awareness of the hearer's state of knowledge. The key principle here is how the flow of discourse

information should be broken down into meaningful groups and organized according to the intended information foci within these units in order to convey the message effectively to the hearer. This role is performed by means of intonation. In other words, discourse is segmented into quanta of information between natural pauses of idea units and further marked off with prosodic prominence by the speaker in the process of communication.

Intonation and Given/New Distribution

In the spirit of Halliday's approach which separates thematic structure from information structure, information structure is expressed in spoken rather than written language. As explicated by Halliday & Hasan 1976:

The information systems are those concerned with the organization of the text into units of information. This is expressed in English by the intonation patterns, and it is therefore a feature only of spoken English. (P.325)

Information structure is the encoding of the relative salience of the constituents of a clause, especially nominals, and is realized as choices among phonological and syntactic arrangements. As will be shown in this section, one common way in

English to encode focused information which is not sentence final is by a high falling pitch on the constituent (i.e., the emphatic stress). This puts the new information in focus as opposed to presupposed or given. However, the stressed part might be also recoverable from the context as something given, only when it is used to make contrast with the previous utterance. So new information that receives intonational emphasis can be either fresh or irrecoverable information, or given information retrieved for the purpose of getting attention of the listener to the contrasted meaning.

Foot and Tone Group

Halliday focuses on the interrelations between given/new information and the phonological constituency of language in his studies on this aspect of information flow. He divides the flow of natural speech into the **foot** (the rhythmic unit of the language) and the **tone group** (the melodic unit, less commonly called tone unit). The foot does not carry any function in the expression of meaning; it is subordinate to a higher constituent above it, the tone group. Halliday argues, "Spoken discourse takes the form of a sequence of INFORMATION UNITS, one following the other in unbroken succession with

no pause' or discontinuity between them" (IFG:295). A tone group is then defined as the unit of intonation that is the realization of an information unit in the discourse, normally coinciding with a clause. The information structure is thus rooted in the prosodic organization and is realized by the three domains of intonational choices, viz., *rhythm*, *tonicity* and *tone*. This 'separating' approach to textual phenomena is one of the most powerful arguments in SFG.

The domain of *tonicity* is defined by Halliday (1970:40-41) as "the assignment of tonic prominence to a particular place in the tone group" and "a means of relating what is being said to what has gone before". Therefore, it is the core element of the information structure. Halliday further emphasizes the difference in semantic status between the *tone group* (the dwelling of *tonicity* or tonic prominence) and the *foot* (the unit of rhythm in English) by pointing out that the tone group is not only a phonological constituent but also a unit of information, whereas "[t]he foot is not itself the realization of any semantic unit" and, in this respect, it is like the *syllable* in that it "does not represent a constituent of any

other kind" except when it carries contrast in meaning based on grammatical accent (IFG:295). Here Halliday has shifted the emphasis from what he rightly pointed out earlier that "both the foot and, more especially, the tone group play an important part in the construction of meaning" (id.:292). One of the examples given by Halliday (id.) illustrates the contrast in meaning through the variation in rhythm:

(2)^o

a. / tell me / **WHEN** he / comes /

'inform me of the time of his arrival'

b. / tell me when he / **COMES** /

'inform me at the time of his arrival'

It is clear to see here that tonicity is the domain which overrides rhythm by determining the variation of its patterns according to the different arrangements of salient syllable(s) that carry the information focus. Perhaps that is an appropriate way to interpret Halliday in more explicit terms as regards the relationship between tone group and the foot with respect to their semantic functions. Natural speech, according to Halliday, can be segmented into tone groups which are further divisible into rhythmic groups. "Such 'prosodic'

patterns are found in every language, although both the patterns themselves and their semantic loading may differ significantly from one language to another" (id.).

Tone and Speech Functions

Information focus in spoken discourse is signalled chiefly by tonicity in English (and in Chinese as well, as will be illustrated in 3.2.3.5) and tonicity influences the sequencing of linguistic elements in a tone group. But, what is the place of **tone**, the third essential element of Halliday's triplet by which information structure is realized?

The *tone* is defined by Halliday as a limited choice of distinct intonational patterns that represent "the very large number of different pitch contours used in speech" (1970:7) and a domain through which the interpersonal function of the "information unit" is fulfilled (1994:302). In distinguishing the function of *tonicity* from that of *tone*, Halliday points out that while the former (through the choice of tonic prominence) "expresses the structure of *information*"--- "how the message is divided into units of information, where the main 'new information' lies" (1970:22) and how the

givenness is determined, the latter "expresses *speech function*" and "relates to mood..., modality...and key...; in other words all the factors which go to make up the relation between the speaker and the hearer, in a speech situation" (id.).

According to Halliday, tone in a spoken interaction may be rendered as a signalling system that functions simultaneously with, but superimposes on, the other intonational systems in establishing a meaningful context for interpersonal exchange of message. It helps shape the information structure of an utterance by realizing some non-tonal systems and sub-systems of tone choices involved (e.g., the grammatical system of *mood* and, the logical relations between successive tone units in a discourse). Phonologically, through the system of melodic contours, it finalizes the information structure by expressing it in terms of the speech function intended by an interlocutor.

Figure 10 attempts to illustrate the twofold function the tone performs in the information structuring and turn-taking. In the cognitive dimension, the tone operates in coordination with the systems of tonicity and rhythm in bringing the

unprocessed information that the speaker is directing to the hearer into realization as segmental and suprasegmental units. In the interpersonal dimension, by means of the linguistic system and through the tone of the speaker (Speaker A), a verbalized and tonalized speech function (**SF a**) is performed, which leads to the formation of the information structure embedded in the response of the hearer (i.e., Speaker B in the next turn), which conveys a related speech function (**SF b**). This expressed function, in turn, ushers in Speaker A's next information structuring which is finally presented, again by the tone, to initiate another sequence of speech functions (i.e., **SF a'**, which is to interact with **SF b'**), and so forth. This sequential organization of information flow in a dialogue situation is maintained by the tonal system that signals the speech function of one turn to elicit the information feedback in the next turn in the expression of a responding speech function and thus carries the chain of interaction forward. It must be noted that from the initiation of a speech function to its tonalized form two main stages are involved, viz., **instantiation** and **realization**'.

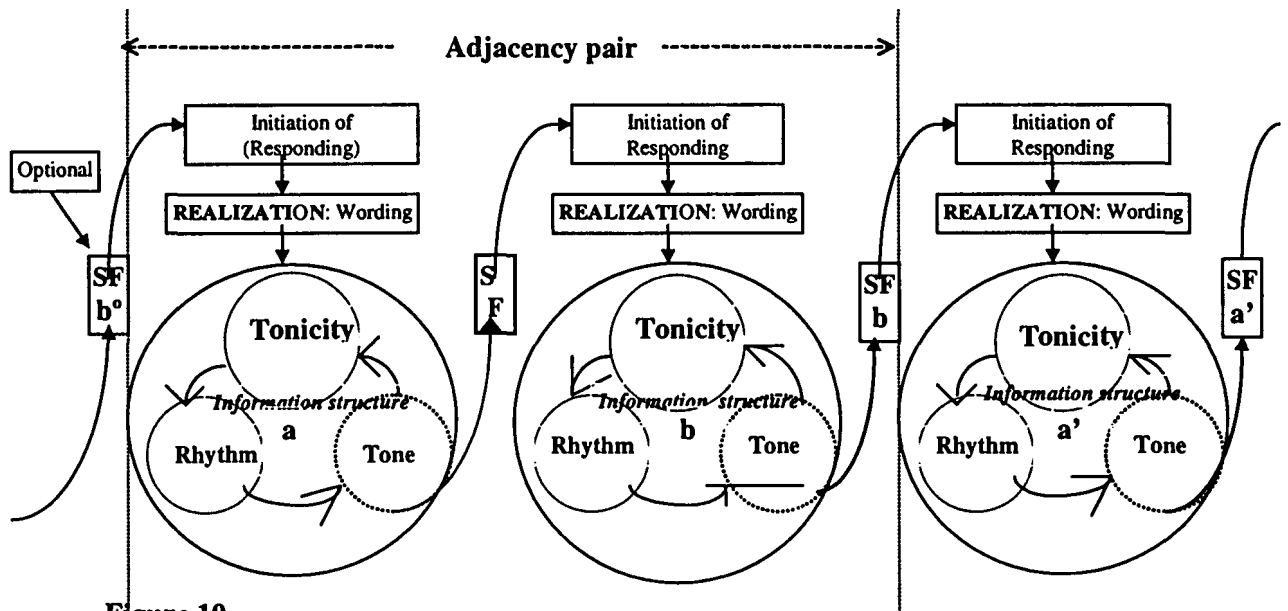

Figure 10

Interactional structure of information flow with the tone construing a speech function on information structure that is to stimulate the response of the other speaker in dialogue

The former covers the selection of information content through the interplay between the metafunctions in the overall meaning system and the environmental determinants (field, tenor and mode) and the choices made "within the semantic and cultural systems" (Malcolm 1994:19). The latter "is the encoding of these choices by means of the linguistic system" (id.). In other words, it formalizes the meaning potential prior to the presentation of text, either in spoken or written forms. In the case of a spoken interaction, the realization stage includes translating the meanings into lexico-grammatical representations (**wording**) and articulating information structure to perform a speech function through the phonological

constituency (**sounding**)(id.:18). Figure 10 has shown a close-up view of this latter component in the *realization* stage.

The relations between types of tone and speech functions in English are generally accounted for in line with the broader theme of intonation and meaning. It has been well documented (e.g., Bolinger 1986; 1989; Brazil 1980; 1995; Fretheim 1987; Halliday 1967; 1970; O'Connor & Arnold 1973) that the cue for approaching spoken data at the outset is intonation, a meaning-distinguishing feature that superimposes on the spoken words and construes the entire phonological constituency. For Halliday, intonational meaning is mainly expressed through the system of tone, because: i) "the falling and rising pitch contours constitute the basic elements of English intonation"(Halliday 1970:23) and, ii) systems of KEY, a network of tone choices, all relate to the mood system (IFG:292, 302).

Apart from conveying an attitudinal meaning (e.g., showing certainty vs uncertainty, or interest vs indifference) and a discoursal meaning (e.g., signalling the end of the speaker's turn), tone may express a third pragmatic function, i.e., showing

whether the speaker is meant to *give* or *demand* something in relation to the listener. Each of these two fundamental types of speech role is distinguished by two variables of "commodity exchanged" as either *goods-&-services* or *information* (id.:68). Since speech function is defined by the meaning of message as exchange, four primary speech functions of OFFER, COMMAND, STATEMENT and QUESTION are derived from the combination of any of the two elements in these two basic distinctions. The speech functions, matched by two sets of possible responses (desired and unexpected), are summarized by Halliday and expressed in the table below.

Role in Exchange	Commodity Exchanged	Initiation	Expected Responses	Discretionary Alternative
give	goods-&-services	OFFER	acceptance	rejection
demand	„	COMMAND	undertaking	refusal
give	information	STATEMENT	acknowledgement	contradiction
demand	„	QUESTION	answer	disclaimer

Table 4

Speech function and responses (From *IFG:69*)

Halliday's schema of basic speech functions is in essence identifiable with speech act theory (e.g., Searle 1965, 1981; Levinson 1983), but it is more semantics-oriented than sociolinguistic and more

restrictedly observed in a dialogue setting than speech interaction in general. It is therefore more promising to be applied as an analytic template in the study of film dialogue and its translation.

3.2.3.5 Implication for Film Dialogue Translation

In sum, Halliday's work on information flow covers a wide range of topics in spoken language production and perception. His most important contribution to this area lies mainly in the aspects of his functional grammar dealing with the inter-dependency of meaning and intonation and of information and prosody, especially his systematic descriptions of the clause, the tone group and their metafunctions in spoken discourse including the relations between tone and speech function. The applicability of a number of Halliday's key concepts to the present study can be explicated through the following discussions.

Thematization and Word Order

With respect to the variations of thematic organization and their degrees of markedness in different languages, English is found to be in the normal word order when the position of the subject overlaps that of the theme at the beginning of a

declarative clause. The most usual form of unmarked theme, according to Halliday, is the one in which the theme, subject and actor are represented by the same one element. It becomes marked if this initial position is given to, for instance, an adverbial group or a prepositional phrase functioning as an adverbial phrase of time or place (adjunct), which is "the most usual form of marked theme" (IFG:44). Halliday notes "[t]he 'most marked' type of Theme in a declarative clause is ... a Complement..." (id.). Elsewhere (p.33) he points out "a possibility of thematic variation, as in *run away I did* ..." to the typical, unmarked form *I ran away*. But he does not explicitly include the possibility of bringing the predicator forward to initial position as a practicable choice to make a highly marked theme. In fact, it is rare to find the predicator in the theme position in authentic English.

By contrast, Chinese tends to accommodate all these clause elements with the position for the topic, which always occurs initially in a sentence (Li 1976) and, therefore, coincides with the concept of theme in the SFG model¹⁰. In other words, such topic-initial word order is the norm, rather than marked structure, in Chinese. In fact, it is

deemed typically "Chinese style" (Chafe 1976) to topicalize or thematize other elements of the clause than the subject, which, indispensable in most clause types in English, is preferably omitted as long as the context meaning is clear in the actual use of the language (see; Xu & Langendoen 1985; Chao 1968). The following examples¹¹ are considered to be typical topic structures in Chinese, which would otherwise be clearly marked if the same word order is found in English.

(3)¹²

- a. Zhe`xie`hua`, wo`bu`xiang`xin`.
these words I not believe
These words, I don't believe.
- b. Ta`hui`shuo`zhe`xie`hua`, wo`bu`xiang`xin`.
he can say these words I not believe
That he could have said these words, I don't believe.
- c. Zhe`xie`hua`ta`hui`shuo`, wo`bu`xiang`xin`.
these words he can say I not believe
That he could have said these words, I don't believe.
- d. Shuo`zhe`xie`hua`, wo` bu`zan`cheng`.
(sb.) say these words I not agree
Saying these words, I don't approve of.
- e. Zhang`jia`, wo` gei`le mei`ge` hai`zi
yi`jian` wan`ju`.

Zhang family('s) I gaveASP every child
one toy

In the Zhang family, I gave every child a toy.

f. Zhei`ge`ren` wo`jue`deji`xing` te`hao`.

This person('s) I feel memory extremely good
About this man, I find his memory exceptionally good.

g. Zai`zhuo`zishang, ta`fang`le` ji`ben`shu`.

Prep table on he put ASP some book
On the table, he put some books.

h. Kan`xi`,` ta` zhi`kan` xi`ju`.

See play he only see comedy
As for plays, he only sees comedies.

These 'Chinese style' examples exhibit a variety of syntactic categories that appear thematically in initial position. The underlined part can be an NP (3-a, -e, -f, -h), VP (3-d), PreP (3-g), a clause (3-b) and a thematized clause (3-c), functioning respectively as an object (3-a, -b, -c), object complement (3-d), adjunct (3-g, -h) and attribute of direct object (3-f) and of indirect object (3-e). We may add here yet another possibility¹³ that thematizes the predicator. This type of thematization, although semantically restricted in limited instances (e.g., the clause must supply end-focus new information about time or place), represents also an unmarked topic structure in

Chinese, and is especially common in spoken Chinese.

(4)

- a. Xue Ying-yu, wo hen chang shi jian le.
learn English I very long time ASP
Learning English, is what I have been doing this for a long time.
- b. Kan xiao shuo, ta tang zai chuang shang.
read novel he lie PreP bed on
Reading a novel, there he is in bed.
- c. Zou le, ta men hou lai.
go ASP they later
Leave, they did later on.

As noted above, the fronting of the predicator is extremely unusual in English unless a most marked thematic choice or special rhetorical effect is desired. So, in (4-a,-b,-c) above, the fronted predicators¹⁴ in Chinese can hardly be rendered into English as such without rearranging other elements in the clause and adjusting the form of the verbal group. Syntactically, this is realized by shifting the predicator before the subject and by filling in the predicate-trace either with an auxiliary verb or repeating the verbal part; however, to achieve translation equivalence functionally this is not a solution. Generally speaking, if such a structure

is to be translated into English as equally unmarked, the inverted word order can not be maintained, except in some cases of informal spoken communication.

Normally, instead of opting for the V-O-S word order to thematize the predicator, English relies more on the less marked *cleft structure* or *WH-structure*. Their equivalents in Chinese (the "shi`... de" and "... shi` ..." constructions), on the contrary, carry more emphasis and are considered highly marked thematic structures. (see Huang & Fawcett 1996; Wu 1996). Prince's observation (1994) that a single construction may have different functions in different languages or a single function may be realized in different constructions in different languages, applies here. In the same vein, Halliday (IFG:208) uses an example (**they cancelled the meeting**) to illustrate the phenomenon that while in Chinese the emphasis on the *process* not the *goal* in the example can be achieved by putting the information focus in the final position through a special Chinese construction (the **ba` ...** construction), "in English it is impossible" (id.). The solution then is found by substituting the *process* with a phrasal verb and splitting it in two: **they called the**

meeting OFF (P.209). Alternatively both in English and Chinese, by foregrounding the goal (the object) so that the process (the verb) is left in the final position as the information focus, the same emphasis can be achieved at the expense of the unmarkedness of the clause. We may then add to Prince's earlier conclusion to the effect that different constructions in the same language may serve a single function only with different shades of markedness in terms of a certain overtone they each carry. This point is significant when translating between two syntactically diversified languages such as English and Chinese, as it will become clearer later.

To sum up, compared with English, Chinese as a "topic-prominent language" (Li & Thompson 1981), has a much freer word order but fewer choices of conveying the emphasis attached to a thematized element of the clause to make it marked. English, being a "subject-prominent language" (Li 1976), is a language with relatively fixed word order and, unlike Chinese, has more restrictions in its manifestation of the theme-rheme arrangement.

Despite the differences, English and Chinese do not differ in canonical word order, both being S-V-O

languages and each having its compatible patterns of thematic structures that correspond functionally to those of the other within an approximate syntactic framework. As meaning is the prime focus in the interpretation of theme, the different patterns of syntactic behaviour and different means of expressing markedness in the thematic status in these two languages become of secondary importance as long as the communicative goal is duly achieved. In translation, especially in film dialogue translation, the flexibility of both languages in this connection allows more room for negotiating meaning through message units of similar textual structures. The employment of intonation mechanisms further reduces the word order differences between the two languages, so that it makes possible the achievement of the ideal translation effect in terms of multi-dimensional equivalence, including lexico-grammatical, textual and informational.

Tonicity and Rhythm in Chinese

Halliday divides rhythm in language into two broad categories: *syllabic* and *pedalian*. The former means the *syllable-timing* type in which the syllable is the rhythmic unit of a language, like

Chinese. The latter is also called by Halliday *foot-timing* for the common term *stress-timing*, with English being a typical example. To illustrate the point raised above that it is tonicity that shapes the patterns of rhythm by adjusting its variables (syllable stress, length and pitch) to form different information structures or to meet different communicative goals, we take the example (2) above to examine the meanings distinguished in Chinese out of the same phonological constituents.

(5)¹⁵

a. / gao`shu`wo` / shen`me SHI`HOU` / ta·lai` /
 tell me what time he come
 Tell me what TIME he comes.

b. / gao`shu`wo` / ta·LAI`de shi`hou` /
 tell me he comeMOD¹⁶ time
 Tell me at the time when he COMES.

It is not surprising to notice that with the tonic prominence highlighting the different focus of information in each of the tone groups, the clause stress falls on the lexical items that carry the identical semantic content in both the Chinese and the English examples in (2). In 2-a, it is the word *when* that receives the primary accent in the tone unit, while in 5-a *shi`hou`* (the time when; when) is heavily stressed; both examples express

exactly the same illocutionary meaning. Similarly, in both 2-b and 5-b, the semantic content is expressed properly through the salient syllable of **comes** in English and **lai'** (come) in Chinese. Comparing the segments of the rhythmic units in the English examples with those in Chinese, we also find a close resemblance between 2-a, 2-b and 5-a, 5-b respectively in the way sequences of ideas within the tone groups are separated, in spite of the different rhythm types to which the two languages belong. Now if we look at another pair of examples used by Halliday (id.:295) in comparison with their Chinese translations, the pivotal role of tonicity as the information organizer and highlighter between the information input (the given and new) and the phonological output (rhythmic and lexico-grammatical representations) will be further clarified.

(6)

a-Eng. /[^] the /question/ WHICH he dis/cussed/¹⁷

(the question : "which did he discuss?")

a-Chi. / [^] ta' /tao~lun`le nei`ge`de/ wen`ti' /

He discuss ASP which MOD question

Back translation:

The question of WHICH ONE he discussed

b-Eng. /[^] the /question which he dis /CUSSED/

(the question that was discussed by him)

b-Chi. /[^] ta~ /tao~lun`guo`de /wen`ti' /

He discuss ASP MOD question

Back translation:

The question that he has discussed

Here, the focus of information in both the English clauses and their Chinese translations is made prominent by means of tonicity. Again it is found that the stressed lexical items in 6-a and 6-b represent the same information focus interlingually, even though in conveying the same meaning as the English examples intend the Chinese renderings have recourse to a different word order with the relative clause preceding the noun in both cases. It is interesting to point out that even this difference could be reduced to none in dialogue translations (in natural or dramatic settings) by adding one or more demonstratives to modify the noun *wen`ti`* (question) in Chinese if the whole flow of information is treated in a larger context. Without detracting from the naturalness of spoken Chinese, this formal approximation in stress and word order between English and Chinese is achieved to satisfy the need of simultaneous cognitive information processing in the case of "on-line" dialogic interaction in lieu of the general translation format between the two languages. Such translation strategies are considered genre-specific and audience-oriented in striving for the "ideal" effect in film dialogue

translation, which is to involve the important issue of the relationship between the translation unit and literal form of the source language in translation (see next chapter for detailed discussion). It is worth pointing out in passing that the stress on the Chinese characters that represents the new information in 6-a-Chi. and 6-b-Chi. is subject to the choice of tonic syllables in the original English examples. If, for example, the stress in 6-b-Eng. shifts to **HE** instead of **discUSSED**, the Chinese translation will accordingly stress the character *ta*⁻ (he) that represents the same semantic realization as well as information focus as in English.

To reiterate, the implication from the above phenomenon in translation suggests that textual representability of tonicity is trans-linguistic and its role as the information filter and given/new indicator in a spoken interaction influences directly the rhythmic organization, and further affects the lexico-grammatical structuring, of a clause. The divergence of the ideational aspect of the languages in the translation of dialogic discourse may be, to a great extent, counterbalanced by the convergence of the textual aspect in the way the means of arranging the

information units and of emphasizing the message in terms of given and new are employed. The upshot of such translation treatment may lead to the achievement of desirable translation equivalence in both formal and functional dimensions.

Five Keys in Chinese Compared With English

Intonation patterns signal types of grammatical structures and indicate speaker attitude and emotions, or suggest other additional information. In spoken English, intonation patterns (or "tones") are expressed mainly by a sequence of *pitch variations* (range, level and direction). Halliday (1970, 1994) has categorized the tones in English into five primary types (coded as 1, 2, ...) and two compound ones (Tone 13 and Tone 53) and ascribed them to meaning in terms of their major and minor speech functions¹⁸.

In spoken Chinese, however, syllable length, or duration, (not the tone of a syllable) play the vital role in performing the same functions. Here, we also assign five tone types (coded as 1, 2... etc.) to Chinese which correspond to the Halliday's tone types to convey the same implied meanings or speech functions respectively. The tones expressed in Chinese depends on the relative syllable length of

the verbal components **neng**^ˊ (could) and **zuo**^ˊ (do): the symbol → represents a prolonged syllable length or the normal stress; ➔ means longer syllable length to mean extra emphasis; and ➡ longest lengthening of the syllable to achieve a 'blockbuster' effect. The symbol ← on the left of a character indicates the reduced syllable length, i.e., instead of putting emphasis on the syllable, it is treated with a shorter and lighter articulation. Example (7) illustrates Halliday's tone system (Halliday 1970:10-12; 1994:302-306) in comparison with the Chinese equivalent devices in terms of types of duration for stressed syllables.

(7)

a-Eng. //1 ^ **he/could do**//

(simple statement)

a-Chi. //1 ^ **ta/neng→ zuo**//

b-Eng. //2 ^ **he/could do**//

('is that what you think? Could he?')

b-Chi. //2 ^ **ta/neng ←zuo**//

c-Eng. //3 ^ **he/could do**//

('I think he could, but it's of no importance')

c-Chi. //3 ^ **ta/neng→ zuo→**//

d-Eng. //4 ^ **he/could do**//

('but he won't, 'but it won't help you', etc.)

d-Chi. //4 ^ **ta/←neng zuo→**//

e-Eng. //5 ^ he/could do//
('so don't you imagine he couldn't! ')
e-Chi. //5 ^ ta/neng→ zuo→//

As illustrated here, tone as the basic element of intonation, as opposed to the concept of phonemic tones in Mandarin Chinese, verbalizes information structure into a speech function. In English pitch contour fulfills the actualization of tone, whereas in Chinese it is the relative duration as the perceptual cue to stress that is the physical material of tone. Therefore, the two pairs of correlates function in the same dimension and for the same effect.

Information Status as Signalled by Stress in Spoken Chinese Discourse

The observation of the phenomenon that, in Chinese, the stress on the new information is realized mainly through lengthened syllable duration with intensity as a subsidiary means¹⁹ diverges from what Tsao (1983) argues that Chinese has to rely on syntactic means such as word order other than syllable stress which is not a viable means to make distinct the new information. In his words, "In English, but not in Chinese, there is another device available to speakers (in oral discourse) to

show the distribution of old-new information in sentences - by means of stress and intonation." (id.:p.103) This ipse dixit, taken for granted in some translation studies (see Baker 1992:136, 151-152), is not without detriment to our understanding of the prosody of Mandarin Chinese, especially with regard to information flow in spoken Chinese discourse.

Intonation is a natural property of a language irrespective of its linguistic affinities. In studying the intonation of Chinese, Bolinger (1989) points out, "... it is wrong to exclude them [tone languages] on the theory that tone languages and intonation languages are separate and distinct classes." (p.49) Then he summarizes that Chinese, as an obvious example, reveals significant broad-scale similarities to nontonal languages in the way different types of focal accent feature different discourse functions. He agrees with other linguists on that these features as basically universal, and "in Chinese the effect of the phonemic tones does not overpower them." (id.)

Chao (1968:35,38) identifies three level of stress in Mandarin: weak, normal and contrasting.

Xiaonan Shen (1993), based on the findings of her studies, first predicts that, in Mandarin, since "the functional load of F_0 is extended to lexical and morphological levels: Stress [sic] distinctions will rest even more strongly on duration and intensity." (p.416). She confirms this hypothesis by carrying out perceptual tests and concludes "that stress in Mandarin can be identified without F_0 information, and that duration is the most important cue." (p.431)

Also from the above illustrations of using tones (in the Hallidayan sense, i.e., the stress pattern in a tone group) to differentiate speech functions, we can assert on firm ground that, like in English, stress and intonation are available as devices for signalling new information in Mandarin Chinese.

3.2.4 Chafe's Functional-Cognitive Model

In the same spirit of viewing melodic units as the basis for understanding information flow in spoken discourse that is more significant than syntactic structure, Chafe (1987) developed a Functional-Cognitive model bearing on a tripartite information structure relevant to spoken discourse. He recognizes an extra property that is intermediate between given and new in terms of the speaker's

assessment of activation cost in the mind of the listener, i.e., the degree of their accessibility to information. In this section, I will first introduce this key concept and a number of other theoretical findings in Chafe's system of information flow in a nutshell. Then I will point out the immediate applicability of his analytical methodology for spoken/written discourse to film dialogue translation.

3.2.4.1 Threefold Distinction of New-Accessible-Given Information

Attaching cognitive significance directly to verbalized chunks of concepts - ideas of objects, events, and properties, Chafe believes that units of information present themselves in any one of three activation states residing in the speaker's and hearer's on-going consciousness, viz., *active*, *semi-active*, or *inactive*, identified respectively with *given*, *accessible* or *new* information. Given information, except when used for contrast, is generally spoken with an attenuated form - unstressed and pronominalized, or even omitted from verbalization altogether. Accessible information, which can be evoked from not so immediate context as the given but is still recoverable with more cost in terms of cognitive effort, usually receives

some degree of stress. But it is the new information in a unit of intonation (see 3.2.4.2) that is vocalized with most prosodic prominence. This accentual distribution is supported by Chafe's hypothesis that "the speaker's purpose in speaking is precisely to bring about changes in the activation states of information in the hearer's mind" (Chafe 1987:25); therefore, the speaker's assumption about what is present in the hearer's consciousness is the prime factor influencing "givenness". In other words, language is a listener-oriented endeavour which is used in such a way that the hearer's cognitive cost to retrieve information during a particular interaction is constantly in the awareness of the speaker so that information is optimally delivered accordingly.

3.2.4.2 Intonation Unit

Basing his system on the *intonation unit* (IU) as the working unit in which spoken discourse is segmented and processed (with a numbered line per unit), Chafe considers this prosodic and functional unit of language to be structurally less problematic, lexically more consistent and cognitively more manageable than the sentence in observing information structure and focus (see *id.*:46). In his words, intonation units are

"spurts of vocalization into which spoken language seems naturally to segment itself." (id.1992:20) and they are "units of considerable cognitive significance" (id. 1993:33). By definition, "[a]n intonation unit is a sequence of words combined under a single, coherent intonation contour, usually preceded by a pause" and "[a]n intonation unit in English typically contains about five or six words, ..." (id.1987:22).

As evidence of "continuing modification" (id. 1993:33) on his system, later additions to this definition include that an intonation unit typically contains "one or more intonation peaks" (id.1988:397), "at least one word with primary accent ... one or more words with secondary accent" (id.1992:20) and that "each segment of speech" (intonation unit) ends in a terminal pitch contour or a "phrase-final pitch contour", which is further identified as either a "non-falling pitch contour" or a "falling pitch contour" (id. 1993:35).

Chafe's *intonation unit* is similar to Halliday's *tone group*. They may be seen as two terms for the same concept of fundamental importance²⁰, i.e., a

new-information-defined unit of spoken language segmented by speech pauses.

The most notable extension of Chafe's system is the observation that some IUs are segmentable into subunits called *accent units*. An accent unit is "a sequence of words built around one word with a primary accent" (id.1992:20), within the same syntactic constituency. The role of accent units as separate idea units which an IU is composed of (sometimes identified with) is further strengthened in his hypothesis that they "verbalize single ideas that are the domain of activation in consciousness"; in other words, each accent unit represents only an item of information that is a focus of consciousness at the moment it is verbalized (id. 1993:41).

3.2.4.3 Chafe's View on the Clause

The centrality of the clause as the basic grammatical unit and its direct relevance to the structure of an IU have been made explicit in Chafe's theory on information flow. On the relation between intonation units and clauses, he concludes, "Each clause verbalizes the idea of an event or state, and usually each intonation unit verbalizes a different event or state from the

preceding, ..." (id. 1994:69). That is to say, the majority of IUs take the form of single clauses. "A small percentage of intonation units are less than clauses, and a few are more." (id.1992:39) They are "either clauses or satellite to clauses" (id.1987:49) or both together. Chafe used the term *extended clause* to refer to clauses plus their satellites, the latter including a piece of a clause (subject or predicate alone), an orientation for one (temporal, spatial or epistemic adverbial constructions) and clausal dysfluencies (false starts, afterthoughts). He then concluded, "the extended clause is an important building block of language, either equivalent to or an elaboration of the intonation unit." (ib.) Therefore, "The clause appears to be the prototypical intonation unit type, ..." (id.:38).

3.2.4.4 Two Cognitive Constraints on Spoken Language

Chafe discovered two constraints under which spoken language operates: "the one new idea at a time constraint" and the "light starting point constraint" (id.:49). The first constraint refers to one of the most important features of spoken language from the cognitive point of view that an IU can communicate no more than one item of new

information. The second, also called "the *light subject constraint*", means that grammatical subjects in spoken language generally serve to express contextually retrievable ideas that are the "hitching posts", or topics as starting points, to which new information is attached (id. 1992:22). Subjects, determined by this role, express information mostly given, occasionally accessible, but almost never new.

3.2.4.5 Sayability and Covert Prosody in Written Language

Writing does not adhere to these two constraints that apply typically to spontaneous spoken language. As far as information density is concerned, the different features between spoken and written language derive from the different circumstances under which they are produced and received. These differences, to interpret Chafe (1992:23-28), can be summed up in terms of two factors: (1) different temporal conditions which the producer (the speaker/writer) is normally subject to --- written language is produced under less time pressure than is speech; (2) freedom of the consumer (the hearer/reader) to adjust the rate of comprehension --- readers can set their own pace in assimilating the information whereas listeners

can only focus on a far less amount of information at a time during the ongoing communication. For these reasons, written language tends to violate the two spoken constraints on information flow.

3.2.4.6 The Analytical Methodology and Its Applicability to the Present Study

Chafe has developed a well-defined, easy-to-apply system for transcribing and analyzing spoken language text, which is based on his theories of the given-accessible-new distinction and the two constraints on spoken language with the intonation unit being the basic functional unit of discourse segmentation, as detailed above. His analytical system explicitly marks all detectable pauses to provide a solid foundation for the subsequent transcription and analysis of spoken discourse.

There are three major steps to take, each involving a series of stages of data processing: (1) identifying separate ideas and segmenting the data for analysis in IUs and accent units; (2) distinguishing given, accessible and new information in each IU; and (3) analyzing the data by measuring them against the established theories. Chafe's transcription system anchors accent units as subunits within each intonation unit. Each

accent unit consists of a sequence of words built around one lexical item with a primary accent, which verbalizes a single idea, activated in the hearer's mind. In other words, the piece of content which receives the most prominent stress is either new or accessible information. An intonation unit contains one or more accent units, hence a cluster of such ideas; but only one of them within a single intonation unit will be new. These are basic clues to understanding how information flows in spoken language from the cognitive perspective. For example, the principle of locating new information according to these conditions can be a key consideration in the analysis of film dialogue, which works consistently with the principles governing spoken discourse. In fact, "[t]hey illuminate important universal characteristics of language, but they can also provide a basis for contrasting the different strategies that different languages use to convey new, accessible, and given information." (Chafe 1994:41)

While Chafe's theories on information flow have mainly drawn on English spoken and written data, his orientation is open to all languages. In fact, his analysis of spoken Seneca (see Chafe 1967,

1994:Ch.12) has verified his statement that some parts of his theories "derive from the mental processes and abilities of all humans, no matter what language they speak, but other things must be specific to English." (id. 1994:146) His examination of the Seneca conversation data shows that, in investigating the information flow in other languages than English, aspects that are sensitive to the particulars of the internal structure and typological delimitation such as the modal length of intonation unit, word class features, word order, deictic usage and other details of grammatical categories, need to be tailored to the description of the language in question, without upsetting the basic outlines of his analytical framework.

In spite of the many particular features in which Seneca differs from English, Chafe concludes that this minority language adheres to the one new idea constraint consistently just like English. He then confirms that "the inability to verbalize more than one independent new idea per intonation unit must reflect a universal limitation on the flow of ideas through consciousness and language." (ibid.:153), and reconfirms that "[the] ability to activate only one new idea per focus of

consciousness seems to depend on limitations inherent in human mental processing, regardless of the language one speaks." (ibid.:159) This phenomenon claimed as universal by Chafe can be attested in the case of Chinese (see next chapter for example) and is of great significance in studying film dialogue translation.

The discrete and sequential nature of the intonation unit in assembling the ongoing conversational interaction makes it an ideal unit of segmentation for spoken language processing. It is also the basic functional unit most natural to the analysis and translation of such discursive discourse as film dialogue. The verification of the theories built on the centrality of the intonation unit, including the one new idea per IU constraint, provides a sound theoretical basis on which the framework for the study of information flow in film dialogue and film dialogue translation can be firmly established.

The rationales of drawing on Chafe's functional-cognitive model for the present study are also due to the fact that Chafe has developed the model in accordance with the cognitive linguistic tradition of the speaking-writing distinction. His

systematic studies of information flow are based on both spoken and written data. Through comparing and contrasting the two different modes of discourse in their similar and different ways of accommodating information, deeper insights to the flow of language and consciousness are gained. This is especially relevant to film dialogue translation with respect to how to consciously adopt different strategies to keep the original information distribution and focus of SL film dialogue for the best dubbing and subtitling effect in their respective media environment.

In this thesis I will adhere to the principles of the analytical system developed by Chafe (1987-1994) as the main instrument of my methodology for the initial phase of segmenting, transcribing and analyzing film dialogue in my translation model.

3.3 Summary

Information flow studies are basically concerned with how the flow of information and the conditions of consciousness are naturally integrated in spoken communication. They reveals the ways the speaker packages the information in a dynamic process of verbalization by means of grammatical devices including intonational means and how the hearer

captures the message intended by the sender likewise within their human capacity.

Theories embraced by the term information flow have opened up a wide avenue of investigation for interpreting and reconstructing language in use. The underlying principles of the functional use of the various linguistic and paralinguistic cues for structuring and retrieving information flow can be broadly summed up as such that the two divisions of analytical parameters, syntax and semantics on the one hand, and prosody and communicative dynamism on the other, should be used all at once in discourse processing instead of being treated independently. In other words, all these sources of information should be seen to work in complete harmony from the point of view of language production as well as perception. The literature reviewed in this chapter has given some hint as to what way the two dimensions of an interaction, i.e., information flow and linguistic architecture, are realized through prosody.

One of the central themes in the study of prosody in this context has been its role in the creation of meaning and the information focus. As made clear in this chapter, thematic structure is viewed

from the perspective of the speaker whereas information structure is listener-oriented, which is based on what part of the message is known and what is new. The communicative effect of the information structure is to foreground a certain idea in an intonation unit , but to background others, by employing prosodic devices. This is the juncture where information flow theories meet the need for theoretical input in film dialogue translation, which is an audience-oriented translation.

In reviewing the translation studies for simultaneous interpretation (SI), Shlesinger(1994) notes, "[t]he functionality of intonational choices and their role in facilitating (or obstructing) communication is by now a universal point of departure in the literature."(p.225) Then he points out, "[l]ittle has been written on the intonation of the interpreter's own output, and its effect on the ultimate addressee has yet to be discussed."(p.226) Such is also the situation for film dialogue translation.

Film dialogue translation bears significant similarities to SI in terms of their "on-line" nature and the cognitive process of translation

production and perception. For his analysis of the production and perception of SI, Shlesinger (id.) uses four broad categories of the salient features of interpretational intonation, viz., tonality, tonicity, tone and prosody. This grouping of intonational constituents derives from Halliday's systemic FG (as reviewed in 3.2.3.4 of this chapter), in which three subsystems of information structuring (tonality, tonicity and tone) are distinguished and, coincidentally, they are exactly what the present study will adopt as essential components of a film dialogue translation theory.

To summarize, the three subsystems, *tonality* - representing the speaker's division of discourse into units of information; *tonicity* - representing the speaker's definition of the focus of information; and *tone* - representing the speaker's classification of the function of information; are key elements of the information structure defined by Halliday and accommodated as such in different interpretative contexts in Chafe's system. They have provided an point of entry towards developing a model for film dialogue translation.

Chapter 3

NOTES

1. FSP, in the present study, applies only to the position adopted by the Prague school linguists, particularly the work of Jan Firbas; instead of being a cover term for any theme/rheme-based approach to information flow as it is sometimes used.

2. In this thesis, the epithet *functional-cognitive* is being used to label Wallace Chafe's model for studying information flow in speaking and writing, instead of "psychological model" as referred to by himself (Chafe 1992a: 216). The main reason for doing so is that, while his observation of language relates directly to the method of cognitive science, his theories stem basically from the traditional functional linguistics with consciousness being centralised as a new theme but without the necessity of formal psychological analysis being fully justified. (See Chafe 1994, esp. chs 2 and 13).

3. The analysis of IF in terms of CD is immediately associated with Jan Firbas' version, which is best presented in Firbas 1992, an overview and synthesis of his work based on much other work in the same Prague tradition but moving far beyond it.

4. Although Halliday claims in this work (the second edition: p. xv) that it does not include the systemic portion of a description of English but only the structural analysis from general to

specific, i.e., the realizations of the deeper systemic features, it is nevertheless regarded as the most comprehensive account of English that has ever been presented within the framework of his theory of SFG, the fuller and more usual term than the *clause grammar*. (For these two terms, see also *id.*:pp.15, 295).

5. Halliday 1994 asserts "the need for grammars of spoken language" as well as "an overview of the grammatical system"; at the same time, he states that "we can attempt a comprehensive view of grammar" (pp.xxxi-xxxv).

6. Linguists like Mathesius, Firbas, Sgall (1973), Dik (1978) and Dijk (1977) who represent or associate with the Prague School adhere to the 'combining' approach to the Theme as opposed to the 'separating' approach advocated by Halliday and other systemicists. (see Fries 1983; Davidse 1987).

7. This is one major area where Halliday's system disagrees with those of other linguists such as Chafe 1994 that marks explicitly all detectable pauses, even within an information unit, although they are considerably shorter.

8. The syllable in block letters in each of the examples receives the tonic prominence, or the primary accent, within the tone group. This indication of the information focus is so emphasized by this writer.

9. These are the two important concepts summed up to denote the two main stages "from meaning

potential to text", viz., **making choices** through the cultural and semantic systems and **encoding choices** by means of the linguistic system (Malcolm:1994). For detailed interpretation of relationships between form, function and context in systemic linguistics, see id.:17-19.

10. *Thematization* and *topicalization* are treated as the same concept in Lyons 1977 (p.500). Although Halliday makes distinction between theme-rheme and topic-comment (*IFG*:38), his definition of *topical theme* that it is the first element that has a function in transitivity and that it constitutes the theme together with anything else that comes before it (id.:53) is only to make the description of the "initial approximation" of the theme in the clause more precise. For the purpose of the present study, this differential detail is not significant.

11. Examples were taken from Xu & Langendoen 1985 with my own arrangement and modifications.

12. In this thesis for citation of examples I use Chinese *pinyin* script - a tone diacritic mark is designated to each syllable (the phonetic representation of a character) immediately **after** it - with the literal translation beneath the corresponding words, in comparison to the English translation to follow. If the source language is English, then the order will be reversed, i.e., first English, then *pinyin* and the word-for-word translation. In these examples, *le*^ˊ is an aspect marker labelled **ASP** and, *zai*[`] is a prepositional marker (**PreP**) that is used with or without a

location specifier such as *shang`* (meaning *up, above or on the surface, etc.*).

The tone marks •, ´, ˇ, and ` represent the first, second, third and fourth tones respectively. There is nil mark following a syllable in the neutral tone.

13. Examples from Chen 1984 with modifications.

14. Three main types of marked theme in English identified by systemic-functional linguists are *fronted theme*, *predicated theme* (also called *it-cleft*; *cleft structure*, or the *enhanced theme construction*) and *identifying theme* (also called *WH-cleft*; *pseudo-cleft structure*; or the *object-as-role-in-event construction*). *Fronted* predicator is the most marked form of the three fronting categories in the first type, the other two being the *fronting of adjunct* and the *fronting of object and complement* (see also Greenbaum & Quirk 1990; Huang & Fawcett 1996).

15. The corresponding emphasis on the stressed syllable(s) of the Chinese character to that used in the English examples in (2) is indicated also by block letters.

16. The particle *de*, which is used in the possessive sense to link up a noun with its modifier, is thus called a modifier marker (MOD) here.

17. In Halliday's coding system the caret ^ represents a silent beat which always appears at

the beginning of the foot. Silence is a systematic feature of the rhythm not only of spoken English but also spoken Chinese, as we can see from these examples. Halliday points out, "... the silent beat also plays a part in grammar, in making a contrast between different meanings" (IFG:9).

18. For the detailed description of the meaning of the tones and the role of tone systems in the grammar by Halliday, see Halliday 1970 and 1994. Briefly listed here the tone types and their respective pitch patterns: Tone 1 = Falling; Tone 2 = High rising; Tone 3 = Low rising; Tone 4 = Falling-rising (rounded); and Tone 5 = Rising-falling (rounded).

19. See Shen 1990, 1993; Jiao & Lu 1996.

20. See Chafe (1994:165).

Chapter 4

A MODEL FOR FILM DIALOGUE TRANSLATION

4.1 Towards an FDT Model Based on Information Flow Theories

The central theme in the study of information flow has been the role of the information structure of discourse in organizing and revealing meaning, including the interdependency of prosodic prominence and information distribution in the case of spoken discourse. By drawing on the concepts, principles and methodologies of the IF studies to inform FDT, our theoretical framework is built on a solid basis because:

- 1) Verbal information-giving in sync with the accompanying pictures is the primary goal of FDT. The translation should not upset the pattern of the original dialogue as visual-centred incremental discourse. In order to enable the 'foreign audience' to experience the same natural way of discourse processing, the original information structure must remain unchanged.
- 2) Prosody and word order in the creation of meaning are crucial to spoken language production and perception (subtitles are also spoken language

text by nature). By means of synchronously-timed stress and rhythm, a faithful film translation can recapture or retain the audio-visual effect of the original as a harmonious whole.

- 3) FDT is different from literary translation in that translation of film and TV dramas aims at conveying the dialogue meaning in the most perceivable manner for the TL-dependent audience. To facilitate processing the on-going bits of information cross-culturally in the screen time available, the intonation unit as the basic unit of film translation can best serve the purpose of highlighting the information focus of each semantic entity and providing easy cues to the speech act function of each utterance.

Before developing our model for film dialogue translation on the above theoretical grounds, some important deliberations are called for to bring into perspective the immediate relevance of the IF theories to some key issues regarding the implementation of the model on dubbing and its general applicability to FDT. For reasons stated earlier (Chapter 1 of this thesis), the discussion and description of our model in this and the next chapter will be focused on its application to dubbing from English to Chinese.

4.1.1 Micro-structure vs. Macro-structure

As can be seen from the previous chapter, the strength of functional linguistics from the information flow perspective consists in its insight into a hierarchy of dimensions of discourse. It allows an objective, manoeuvrable point of view to pan over all levels of spoken discourse: not only its linguistic makeup and informational content, but also its socio-cultural context and interactional organization. It should be stressed that, failing this realization, studies dealing with IF in spoken discourse, purely from the standpoint of information structure, tends to leave out the interactional dimension despite the fact that the former is complemented by and dependent on the latter. Among other prevailing dichotomies in discourse studies, the cleavage between information flow and social interaction has been challenged and approaches incorporating both criteria to the study of spoken discourse have been proposed (e.g., Geluykens 1994; Givon 1997).

Information flow in spoken discourse is, in essence, the outcome of an interactional activity. The dependence of information processing on interaction is determined by the conversational

goals which govern the topic shift and specify the relationship between the micro- and macro-levels in conversation. The former level is concerned with linguistic and extra-linguistic factors contributing to the presentation of information, including the new-given articulation, the prosodic mechanisms, the segmentation constraints, the function of a speech act and the meaning of a dialogue move. On the macro-level there are "large-scale information units" (Swerts & Geluykens 1994) comprising a sequential organization and its infrastructure: the conversation goal, the topic flow, the turn-taking system, the conversation structure marked by the division of speech act sequences, etc. Thus, in view of spoken discourse operating on both levels, information flow is more appropriately understood as "a goal-oriented process" (Geluykens *ibid.*:253).

Understanding information flow in the anatomy of macro-organization of spoken discourse reveals "the interactional collaborative dimension" (*id.*:257) of the conversational genre which is built on a nexus of topical internal structure marked off by the embedded conversational goals. From communicative and social perspectives, a basic structure consisting of initiation, uptake (the hearer's

feedback) and termination of the goal represents the progression pattern of the goals on the macro-level and "it is precisely these goals which structure conversation" (ibid.).

Film has its underlying hierarchical structure branching out from a whole coherent story to a series of acts, sequences, scenes and, shots, which is the smallest unit of film construction. The immediate constituent of a *speech event* is a *speech act* and the same *speech act sequence* (SAS) is normally accommodated within the bounds of a film scene, which spatiotemporally corresponds to a speech event. In other words, the scene in a film is an independent unit with a single general topic which contains one or more goal-centred speech act sequences.

In film dialogue, the development of goals as planned topics is also a cohesive force that sustains the information flow on the macro-level. The boundary marker of the basic unit at this level in most cases coincides with the identification of speech act, which can be made even less problematic than that of spontaneous conversation in natural context¹ by following the principle underlying the 'dialogue paragraph' model (Klammer 1971, Snyder

1980) as applied to dramatic discourse. It is, therefore, theoretically and technically feasible to take the speech act sequence as 'major blocks' of the macro-structure of film dialogue for translation purposes. On the other hand, prosodic, lexical and syntactic choices such as stress, the idiom principle (Sinclair 1991), word order, as instruments for establishing the micro-level, are ultimately determined by "pragmatic considerations to do with the purpose of utterance, real-world conditions and so on." (Hatim and Mason, 1990:101).

The necessity of adopting a comprehensive view of the information flow theories for incorporating them into film dialogue translation process is significant and self-evident. The micro-macro dimensions as structural, cognitive and pragmatic correlates are complementary and inseparable in a viable spoken language translation theory, which is most appropriately configured by the fundamental principle of ATS (analysis-transfer-synthesis) in the standard machine translation (MT) whereby our model for dubbing is eventually developed. Therefore, in applying the model for both translation production and description/evaluation, the film discourse needs to be dissected into parts, acts, scenes, speech act sequences, and

intonation units and be viewed in such top-down perspective and vice versa.

4.1.2 Literal translation and SL-oriented translation

As noted previously, film translation is described fittingly as "a hybrid between translation and interpretation" (Scandura 1996). Many of the principles and techniques suitable for simultaneous interpretation can shed light on dubbing. For example, intonation and word order in the production and perception of simultaneous interpretation hold similar functional significance in the same aspects of dubbing. Although dubbing and subtitling is a planned, lag-free simultaneous interpretation, the outcome of which serves the eye more than the ear, the translation strategy remains the same as that for natural speech interpretation with respect to how to organize the ideas in manageable units and how to present them in a linear manner that is most economical in terms of cognitive load on the listener. In this connection, film dialogue translation is source-language-oriented in terms of word order and prosodic emphasis.

However, because of the formal affinities between FD and drama dialogue, film dialogue translation is easily confused with drama translation which is in essence a type of literary translation with a different order of priorities. For example, to strive for idiomatic representation of all the nuances and beauty of meaning and style in SL, the original form usually has to undergo major reconstruction to bring into play grammatical and phonaesthetic devices and patterns comparable to those in the TL. This is certainly not fit for dubbing. What dubbing/subtitling contributes to the highly constrained medium it deals with is spoken words, but they must mix functionally and harmoniously with the images and other codes within the time slot pre-set. Dubbing, for instance, should not set its standard for creating a voice that sounds exactly like that in home-made movies. This is hardly possible and utterly unnecessary.

The spoken words must match the picture in reinforcing the socio-cultural identity of the screen character as perceived by the audience. Elements of culture-specific implication and the necessary exotic flavour are to be reflected only through the character's language form (the special case of using a different accent is being excluded

here). Idiomatic or free translation can rarely achieve this property and may even ruin the sound-picture harmony completely. In this connection, the translation principle advocated in Benjamin (1968) is particularly true:

Good translation does not seek to dispel the foreignness of languages but on the contrary allows its native language to be affected, expanded and defamiliarized by the foreign tongue. Therefore, the translator engages in the task of transforming the totality of his native language by liberating it from the servitude of sense and sending it adrift to pursue its own course according to the laws of fidelity in the freedom of linguistic flux. (p. 80)

Newmark's unequivocal remark suggests what could be the available strategic choice: "... obviously, if the genius or the particular of the foreign language is to be preserved, cleanly and straight, only two procedures can preserve it - transference and literal translation." (1991:124) But the question remains: what is the formal limit of this desirable foreignness in translated film dialogue? In principle, the main criteria for the allowable degree of the linguistic exoticism retained in the target film dialogue can be established according to two parameters: informational truthfulness and audiences' perceptibility. In other words, "[i]f

at all possible, s/he [the translator] should make an effort to present the target text from a perspective similar to that of the source text" (Baker 1992:172), in so far as the information of the original dialogue remains functionally intact and undistorted and is readily understood and willingly accepted by the audience. So far such SL-oriented translation has been a good answer, at least in film dialogue translation between English and Chinese.

SL-oriented translation in most cases means literal translation but it is more than that. In the case of dubbing, unlike other types of translation, it demands a synthesis of instantaneous effect. The arena of the competition for the best possible translation of a film is a testing ground for the translator to envisage while renewing a drama by contributing to the original multisensory impact that is directed to the target audience and that does not lose momentum or change course through revoicing the character in a foreign language. This challenging translation task makes more allowance for interpretation with regard to what is the ideal TE that should be finally decided by "the Pragmatic Other" (Ruuskanen 1996:893), the foreign audience. They are sitting in front of the screen

not to be incommoded by the intrusive features of the characters' speech but guided by light, naturally-fitted utterances; they are prepared to be minimally distracted by these, while they rely on them subconsciously.

As mentioned earlier, dialogue in a film can be first cut up into parts and/or acts and further divided into scenes which are the highest self-contained unit at the macro level in the film discourse. In a scene (only a dialogue scene as opposed to an action scene is being considered here), FD is organized in speech act sequences and turns, each performing a general speech act function that is part of the FD function. Each turn is then segmented into intonation units (IUs) with one item of new information per IU. According to Chafe, new information is the focus of an IU and is given a primary accent to make it the nuclear (or tonic) syllable (also called nucleus in the British tradition) of the segment and it is where the terminal pitch contour begins. It is one of the most important objectives of dubbing (and subtitling) under this model to transfer this crucial part of an IU into TL in such a faithful way that not only the information content must be true to the original but the corresponding word or

phrase in TL must be received in sync with the original timing for this item and with equal prosodic prominence. With this new information in sync (NI-sync) with the facial expression (especially lip movement) and body language of the speaker visible on screen, the other words in the same segment will be expected to "fall into place" in proximity to the original loci so that word order equivalence is achieved at least at the level of IU.

For the Chinese text a lexical item to represent the idea (concept) of NI can be a character, a character combination or an idiom, depending on which is the best equivalent both in meaning and in form. In every IU this key lexical item for the dialogue line should and can be voiced or projected, as closely as possible, to the original time slot for the NI in English. Even though phonologically English and Chinese are two differently-timed languages with wide gaps in many respects, both are SVO languages in the first place. And from the point of view of language typology, the flexibility of both languages, especially in conversational style, makes it possible to strive for formal approximation in dubbing. For example, English is more isolating

than many other European languages (LDAL:150) and "[t]o a certain degree, English is also an analytic language" like Chinese (DLL:181); and spoken Chinese allows more room for inversion, whether it is due to topicalization, clausal right-dislocation, in-speech-turn shift of deictic centring or varieties of repairs including afterthought. Take for example²:

(1) [Jackie: Sc. 1-1.16]

...A Great ^^beauty | ^she is!
(new)

...Xiao ~^^mei ren | ^zhen ~shi `ge`!
'little belle' really be MSR'

(Cf.: Ta ~zhen ~shi `ge` xiao ~mei ren`!
'She really be MSR little belle!')

(2) [Jackie: Sc. 1-2.4]

(1)...I ^^don't want to be a ^schoolgirl
(new)

...Wo ~^^bu `xiang` dang ~^xue `sheng` le
'I not want be student ASP

(2)... among ^^schoolgirls. (12 syllables)
(new)

... quan ~ zai `^^nu` hai `zi` li. (13 syllables)
encircled PreP girls LOC'

(Cf.: Wo ~bu `xiang` zai `yi` qun `nu` xue `sheng` zhong
'I not want PreP one MSR girl student LOC

... *dang ge nu xue sheng le.*
be MSR girl student ASP')

(17 syllables)

These two dialogue lines would have been impossible to put into "idiomatic Chinese" if they had not been treated in the IU and if the prosodic means had not been employed to achieve the TE functionally. Compared with the original translation (represented by its word-for-word back translation into English) in brackets at the bottom of each example, the improved translation underneath the original English dialogue lines is considered formally and communicatively matching. By using this method some thorny translation problems can be automatically solved satisfactorily. An example from my translation of the American teleplay *A Million-dollar Face*,

(3) [Face: Sc. 2-6.29]

(1)...Glamour Inc. will ^^win
(new)

...*Guang yan gong si hui ^cheng gong*
'Glamor company will succeed

(2)... not ^^because of you
(new)

...*bu hui shi ^yin wei ni*
not will be because of you

(3).. but in ^^spite of you!
(new)

... *shi` ^you ~ ni ~ ye ~ bu` ^^zai` hu!*
be have you still not care'

(Cf.: *Guang` yan` gong` si` ~ you` mei` you` ~ ni` ~ yi` yang` cheng` gong` .*
'Glamour company have not have you still succeed')

However, some NI-sync is not always achieved because of the discrepancies of the two languages. Even so, the information focus is voiced in the close vicinity of the original locus and taking the IU as a whole, the NI being stressed is functionally comparable to the original in terms of timing and semantic importance (Example 4).

(4) [Jackie: Sc. 1-1.16]

(1)...We're going to ^^love her
(new)

...*Wo` men` hui` ^^ai` ta` !*
'we will love her

(2).. more than ^any child | in the ^^whole ^^world!
(new)

..*sheng` guo` shi` jie` shang` ^^ren` he` hai` zi` !*
more than in the world any child'

(Cf.: *Wo` men` hui` `bi` ~ ai` `shi` jie` shang` ren` he` `qi` ta` ~ hai` zi` geng` `ai` `ta` .*
'we will than love in the world any other child more love her')

Here, the Chinese translations have attained the level of naturalness suitable for the spoken language in a film.

To sum up, for the film translator, the freedom of making choices between foreignizing and domesticizing the target language (Hatim 1996) is delimited in FDT where the former option prevails throughout the translation process in keeping with the 'originality' of the film dialogue to yield to the special demands of the film medium. SL-oriented film dialogue translation, basically by literal rendition, can be defined as integration of "semantic translation" and "communicative translation" (Newmark 1991:11-13) which is informationally and interactionally interconnected to the extent that the new information saliency and word order agreement between the two languages in translation are maintained at the level of information segments, i.e. the intonation unit. Paradoxically, this type of incremental "close translation" (id. 1988), instead of inviting the problems of "translationese" (id. 1991), eases the tension stemming from the linguistic/cultural differences, gives the translator more room for creation, and eventually adds an illusory power to the cinematic experience desired by the audience, for it can efficiently minimize "linear dislocation" (Baker 1992:167) in translation and best preserves the "translational character" (Newmark 1991:124) of the target language that

reflects the spirit of the original movie talk. Such necessary literalism in FDT is "the scientific principle of a full translation" (id.:125) if it is applied for the right purpose, in the right manner and to the right place.

4.1.3 Unit of Translation of Film Dialogue

Translation studies, by tradition, tend to make a clear-cut distinction between word-for-word translation and literal translation, which is considered to be a lower level of translation than free translation. These three broad categories of translation correspond respectively to three tiers of translation equivalence being aimed at. Literal translation is similar to word-for-word translation in that a TL equivalent is given for each SL word as far as possible; but, unlike the latter where a series of TL words are simply strung out in the order in which they occur in the SL text, it is adjusted to meet TL requirements, where necessary, with minimal changes made in accordance with the TL grammar. Such classification of translations is based on the grammatical rank to which the unit of translation (UT) for each type is bound. SL-oriented translation in the context of FDT, while sharing some characteristics with literal translation, is not to be confused with the

related concept derived from the above typology because it is a prosodic rather than syntactic unit that the UT of film dialogue is identified with.

A single, categorical definition of UT has been attempted by many in the field of translation without much success: most versions being either too fuzzy or overgeneralized. The reasons are obvious. Different translation tasks rely on different strategies with regard to the grammatical units between which translation equivalents are selected. Furthermore, each translation task often has recourse to different syntactic levels at which the most appropriate UT for a particular stretch of text is chosen. There is also "the bilingual character of the question of unit" (Swadesh 1960) to consider: what is a unit in one language is not necessarily so in the other. (p.436); besides, the concept of UT varies even within a single language (p. 438). "In normal translation", as underscored in Catford (1965:24, 1994:4742), the UT is not bound to a particular rank in the grammatical hierarchy, but is constantly changing. This reaffirmed statement finds in total agreement the conclusions in Newmark (1988:67) that "the unit of translation is a sliding scale" and in Barkhudarov (1993:41) that UT, proposed as "a unit of

translational equivalence" (p. 40) to be more precise, "can be a unit on any of the levels of language" (p.41).

However, in translation dealing with spoken language such as FDT, the generally-received theory of UT, as being either the sentence or a variable shifting up and down the grammatical rank scale, does not apply. Newmark shows that "operatively, most translation is done at the level of the smaller units" (ibid.) than the "natural" unit of translation, i.e., the sentence, which is "virtually irrelevant in speech" (Sinclair et al. 1975; re-quoted from Newmark ibid.). Catford (1994) also acknowledges that it is "quite possible to carry out a translation in which equivalences are deliberately bound to a particular rank" (p. 4742).

The debate on the unit of translation seems to be a never-ending tussle for imposing supremacy, the length and breadth of which is comparable to that of the dub-sub polemic. This old question, however, has taken on much renewed interest and extended significance in recent years in spoken language translation, MT and research on spoken human-machine dialogue systems (translation in its broader sense). One major concern in this line of

research is how and where human and machine translation learn from each other. Paul Bennett has illustrated that UT for MT tends to be smaller than that for human translation and the sentence is "the translation macro-level" for MT (1996:16). The overwhelming view held in the literature on utterance unit of spoken language (e.g. conference papers for ECAI-96 Workshop³) coincides with the principle of spoken language segmentation in the functional studies on IF, in all of which the golden rule of translating (analyzing) spoken language sentence by sentence is bypassed and prosodic information revealed in each clause-length segment is given due respect. The speech act function is also used as an important mechanism in processing and transferring dialogue.

One of the most important differences between film dialogue translation and the 'normal translation' is that there are much stronger demands on the quality of output in terms of clarity and its compatibility with the visual. A high-quality audio-visual translation must fulfil several other criteria: it should preserve the meaning and the style of the original utterance and be idiomatic by the TL standards as well; in particular, it should contribute faithfully to the overall effect

(informational, emotive and aesthetic) of the discourse as created in the original.

In the last chapter, I have claimed that information structuring/segmentation and prosodic properties are fundamental to our understanding of spoken language and the best answer available to a satisfactory problem-solving approach to FDT has been found in the principles of functional grammar and cognitive linguistics, most promisingly, in Chafe's work on IF in spoken/written language. The most important input from this model is that spoken discourse is structured in two major dimensions: prosodic and grammatical. Being "generally complementary and mutually supportive" (Lyons 1995:181), they converge on the unit of information which reflects the increment-by-increment presentation of speech. The central role of the information segmentation in terms of the intonation unit and the clause (including clause fragments) as represented respectively in each of the hierarchical structures, is determined by the special demands and constraints under which IF operates in spoken communication. Compared with the latter, the intonation unit is more stable in length and descriptive in representing the features of spoken language. The definition of the

intonation unit as a segment of discourse spoken in one unbroken prosodic sequence conveying only one item of new information per unit, is consistent across different languages and, cognitively and formally, it qualifies as the unit of translation equivalence of a SL information unit that corresponds to a match in the TL spoken language text. For all the above reasons, I choose the intonation unit as the UT of film dialogue in my model for film dialogue translation.

4.1.4 FIT - the Principle of Equivalent Effect in FDT

Like the thorny question of the definition of UT, translation equivalence (TE) is also a key concept not readily definable and subject to empirical choices and interpretations because of its relative measures in the translation process. It is also intrinsically related to a number of other contentious issues in translation studies, such as translation shifts (Catford 1994), (in)translatability and translation quality assessment, in that all exhibit considerable variability according to different translation situations. By common practice, TE is measured in terms of the principle of equivalent effect on which a systematic theory of dynamic/functional equivalence is built up by Nida and others (see Nida 1964, Nida & Taber 1969,

Jin & Nida 1984 and Jin 1989). While acknowledging its great value and positive influence on TS, Chang (1996) points out that the principle of equivalent effect is only valid for certain types of translating. He suggests that a generally applicable theory of equivalent effect "should have different emphases for different types of texts depending on their inherent or intended functions" (p.14), and that it should also take into consideration the specific problems of different text types, the purpose of a particular translation task and the need of its target language users. In this study, the principle of equivalent effect applied to FDT is to be modified in accordance with the transference of the film dialogue's functions into the TL equivalence in factual, illusive and textual dimensions (aconymed as FIT in the following).

4.1.4.1 Form and Functions of Film Dialogue in the Context of Dubbing

The Principles of Scriptwriting

Before discussing the role dialogue plays in a film, it is necessary to bring to our attention its generic features that reveal what is considered to be good film dialogue and how it works in collaboration with the visual. Since film is so

created as to assume real-life events to the point of dispelling disbelief, its dialogue is situated in a series of carefully reproduced speech events (in terms of scenes⁴). Piecemeal or self-contained, they can be recognized and treated as the basic functional units of film's Macro-structure for descriptive purposes. This ethnographic perspective "... of an analyst looking at a strip of social interaction from the point of view of the speech in it" (Duranti 1985:201) is adopted here as the starting point of making sense of film spoken discourse.

Film dialogue depends on a written script, even though there are external and internal factors that result in discrepancies 'from page to stage'. Since dialogue simulates natural speech but at the same time distinguishes from it to the extent of being able to subsist on the constrained timing affordable in the medium environment, the stylistic and contextual characteristics of film dialogue are so normalized as expressed in the following general guidelines for scriptwriting with regard to dialogue.

- It must be understandable the first time and facilitate the comprehension of the whole movie.

- People speak in their own rhythm, so each character should have a unique speech pattern.
- In informal situations, people tend to speak in half-phrases, so realistic dialogue should likewise sound 'jumpy'.
- Dialogue usually is not longer than 3 continuous lines, as long speeches on screen can be deadly, which must be avoided unless in exposition scenes (approx. 3 ¼ minutes is long enough for most movie scenes).
- Words are a means of expressing characters' mood and emotion which enhance their action. Most people never say what they really feel. Characters don't need to talk about what will be visually displayed within the scene action. In other words, dialogue and visuals don't duplicate.
- Good dialogue is that which goes against, or is contrary to, the action of the scene. Words uttered by the characters but contradicted by their body movements and actions create the most dramatic and effective scenes⁵.

Apart from these demands for making film dialogue sound desirable in the way it normally is, the scriptwriter is also encouraged to try to make his story understandable without the spoken word as far as possible. This extreme view only implies the meaningful existence of dialogue in performing the functions that can not be replaced by the other means of expression in a film. Even though film

dialogue shows only grudgingly the typical features of unplannedness found in real conversation in terms of unpredictability, inexplicitness and non-fluency⁶, film dialogue works by the grammar of natural speech and resembles its speech-act patterning.

All these important features should be faithfully transferred to TL in translation. As explicated earlier, film dialogue translation will benefit from the theories on information production and processing in spontaneous conversations if FD is treated as such. But in the last analysis it is the functions FD serves in film that determines its form.

FIT in Film Dialogue and Its Translation

The functions that film dialogue serves in a film have been enumerated and proved in almost any book on screen scriptwriting or the pertinent part on dialogue in film studies⁷. However, their weight in film dialogue translation has not been adequately recognized. There is need to re-evaluate the functions of film dialogue to define, from a linguistic point of view, their immediate relevance to translation goals set for dubbing and subtitling. To incorporate a largely neglected

film dialogue function (the second one on the following list) with all the commonly detected ones in a nutshell, we arrive at a dubbing-oriented film dialogue function classification under three main headings:

<i>Function</i>	<i>Description</i>
Fact (<i>What</i>)	to give information and tell the story in words; to present exposition and explain what has happened but not been shown; to suggest nature of each character and reveal aspects of characters not otherwise seen
Illusion (<i>How</i>)	to keep the human speech naturalistic-sounding as part of the cinematic illusion; to set the tone of the film (sociolinguistic background and the register of the particular film genre)
Textuality (<i>Why</i>)	to advance the plot or move the storyline forward; to develop issues of the story and set up next event; to add conflict; to maintain the cohesion and coherence of the film discourse

Table 5

Meaning of FIT

The whole meaning of dubbing resides in the transfer of these three functions (FIT) from one language into another, i.e., the film dialogue in the target language (FDt) is expected to fulfil all these same functions that the film dialogue in the source language (FDs) does. But first and foremost, film dialogue serves to provide the audience with information that must be comprehended simultaneously with the other ongoing message from the film. Information in this context means the

factual content, or propositional meaning (as defined in Lyons 1995:44), the addresser (the scriptwriter/ film-maker) intends to convey to the addressee (the audience) through film dialogue. Obviously, achieving translation equivalence that satisfies this primary function not only ranks above all the priorities for film dialogue translation, but also poses a much greater challenge to the effectiveness of its information delivery than that of other types of translation which have fewer medium constraints on the information perception of the TL receiver.

With regard to film dialogue, the foreign audience takes seriously what the native-speaker audience takes for granted, i.e., the spoken words in their own language should be understandable the first time. In the case of subtitling, audiences are most concerned about whether the subtitles can give them partial or even the whole answer to what is happening on the screen. For those relying on the dubbed dialogue, it is "What are they talking about?", rather than, "Do real people actually talk like that?", that becomes vital to their experience in the 'cinematic foreign country'; although their expectations are usually (at least consciously) far from being reduced to such a basic need. This is

because the other two functions, especially the second function - to create a 'linguistic illusion' - can be fulfilled effectively on the basis of the faithful and timely rendering of information. In fact, it is part of the theme of this thesis that the other two functions will be functionally "in place" if the translation of the first function is handled properly.

This irreversible role of the information-giving function, which affects the other functions positively - but not vice versa - can also be proved by the deviant use of dubbing on purpose either to impress viewers with some image being advertised⁸ or to produce an amusing effect in a funny video⁹ in which the original film dialogue is revoiced in a new dialogue with a totally different meaning and a highly deluding effect. On the other hand, such a substitution trick is "a routine method of censorship in totalitarian countries" (Minchinton 1992).

The Role of the Film Translator

Without underrating the goals of dubbing, what is stressed above is that, although it is the aim of the dubbing translator to recapture all the functions that FDs carries to be represented in

FDt, the first function of FIT must always be in control in the translation process when it comes into conflict with the realization of the other functions. That is where different types of loss in translation may occur. The loss, caused inevitably by erroneous approaches to dubbing as well as the special constraints on the FD translator's task, can be identified as loss of meaning, rhythm, formal features, colloquial style, synchronization or speech act force, etc.. And all these can be subsumed under the concept of FIT, viz., loss of FD functions (Figure 11).

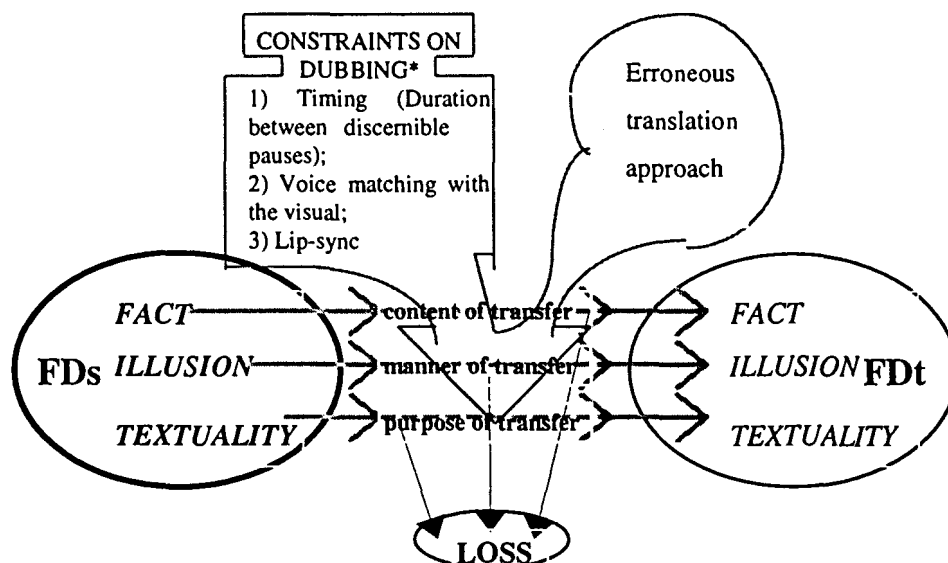

* After I. Mason (1994:1067)

Figure 11

Constraints on dubbing and types of loss

To a limited degree, different types of loss of FD functions in dubbing may be compensated for by employing such translation techniques as expansion, reduction, substitution and summarization (see Wadensjö 1993; Chang 1996). In reality, the ideal that a dubbed film should offer the viewer a new dialogue that restores all the functions of the original can rarely be achieved. However, the translator, in his/her effort to conspire with the dubbing actor to create an illusion true to the original story, can realistically aim at avoiding unnecessary loss of FD functions by adopting appropriate genre-specific strategies and tactics in coping with the translation constraints. This means that translating for dubbing must seek unconventional methodology built on its own principle of equivalent effect (FIT) to obtain the optimum translation equivalence because of its special translation circumstances and the highly demanding target. FIT as a key variable that affects the quality of film translation, chosen and applied correctly, can reduce the loss to a minimum.

Unnaturalness seems to be inherent to Fd; although the contrary is also heard from those less concerned and less critical - "They are doing

quite good dubbing nowadays!", for instance. Such comment pays credit to the dubbing talent performing on the screen rather than the translator working behind the scene. Even though dubbing as a translation process bristles with more problems than dubbing as a performing art and even though it is not uncommon in actual practice that the translator is not the one who finalizes the dialogue lines, it is the translator's work that forms a sound basis of the whole art of dubbing, or undesirably, becomes "the root of all evils" (Herbst 1995:269) if "the rough translation" is not "done with any great care because [of the self-effacing assumption that] the text gets changed anyway" (ibid.).

The essential function that the FDT text fulfils in the film translation process can be better understood if we view FDT as a unique communicative act between the *Sender* (of film as message) and the *Receiver* (the target audience) with the *Translator* (and the dubbing crew) being the language mediator. To take a lead from Uwajeh's performative model of translation (Uwajah:1994:247), the place of the dubbing translator as the "stand-in communicator" determines that the "acting out" of FDT - a code-

resynthesizing stage realized by the dubbing director and actor - depends on the information and the language form, i.e., the FDt script, that the translator provides (Figure 12).

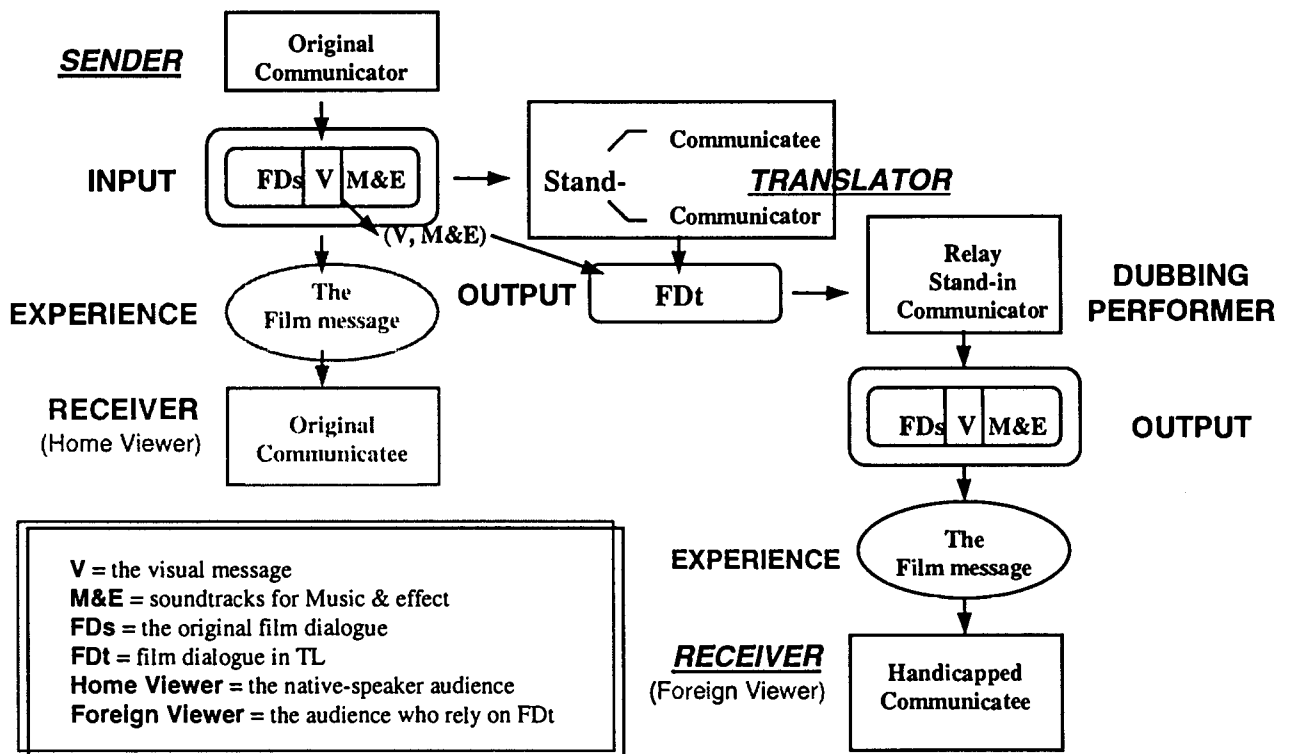

Figure 12.

The role of the translator in the dubbing process

Obviously, a fully-functional TL dialogue script as the outcome of working with a scientific approach is the key to achieving the best possible translation equivalent effect. In the course of his communication with the target user of the FDt, the translator acts as an innovative and creative writer who is competent to turn both the form and

functions of the original film dialogue into the TL with FITness.

4.1.4.2 FITness - Standards for Evaluating FDT Quality

We distinguish **FIT** as the intended functions of the original film dialogue from **FITness** as the equivalent effect produced in film translation. In other words, the FIT-fulfilled FDT with both the form and functions of FDs preserved can be described as possessing the quality of *FITness* (i.e., fitness achieved because of the maximal retention of FIT in a film translation). This FDT-specific paragon is parallel in notion and standards to *naturalness* (As-Safi & Ash-Sharifi 1997) or *appropriateness* (Sager 1989) which are regarded respectively as the hallmark of a superior literary translation and translation in general. Each of these epitomical attributes is achieved through manipulating successfully all the relevant parameters for a defined area of translation which affect its translation quality assessment (TQA) and which are also factors significant in construing the norm of parity for the translation process. By way of introducing two influential models of TQA followed by a closer look at FITness in FDT, the question of how to specify criteria for evaluating film translations aimed at assessing the value of

the product (macro-evaluation) and/or improving the product (micro-evaluation)¹⁰ is hoped to be initially addressed.

Translation Quality Assessment

A yardstick of translation quality assessment exists only in relative terms. There are various approaches to TQA characterized by different criteria and methods which are determined by different objectives of evaluation and affected by other variables involved in the translation process.

J. House (1981), by drawing on theories of contrastive linguistics, proposes a model for TQA which makes parallel comparisons between ST and TT via metalinguistic mechanisms from the perspectives of functional and socio-cultural transference, concentrating on the macro structure of the translation and its effect. The basic framework of this model is focused on the intended functions of source language text (SLT). House has contrived a unified analytical system which can be applied to most types of text to define SLT form and function. They can then be used as the criteria against which to check the target language text (TLT) to find out mismatches of the two texts, so that quality

assessment can be stated according to the translation problems detected (Figure 13).

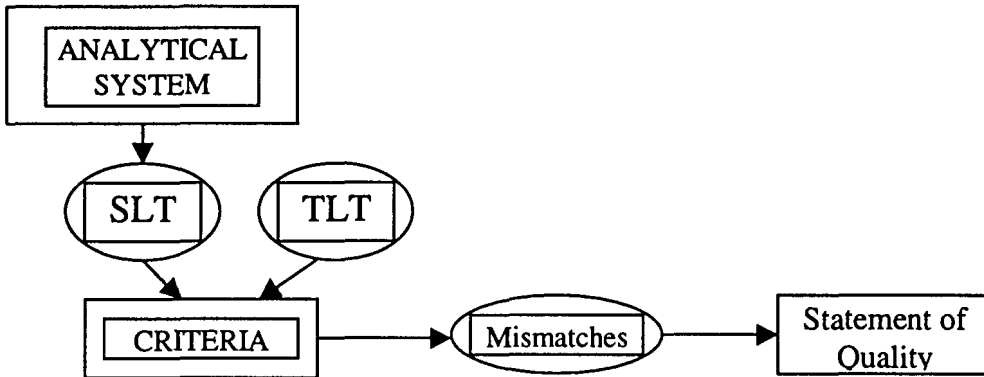

Figure 13
The Translation Quality Assessment Model developed by House (1981)

Hermeneutic in approach, the TQA theory formulated by R. Stolze (1996) consists of detailed evaluation parameters, including four **translatoric categories** (*thematics, lexis, pragmatics and stylistics*) combined with 3 different **perspectives** viewed by different product users to each category, *dynamic* (translation professionals' perspective), *static* (teaching perspective) and *prospective* (client perspective). The assessment criteria she has set up are translation user-oriented (Figure 14).

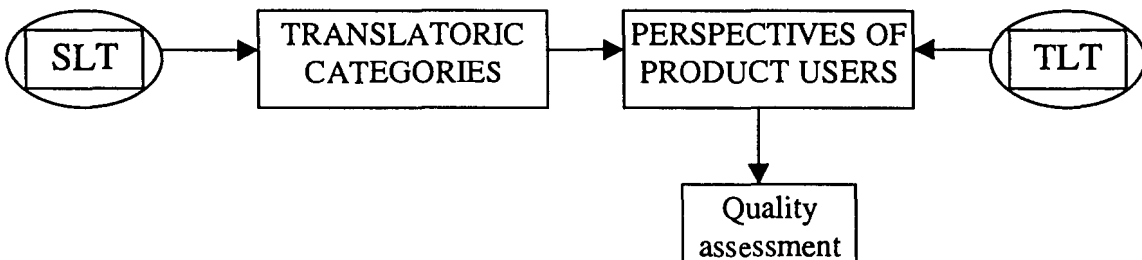

Figure 14
Interpreting the Translation Quality Assessment Model by Stolze (1996)

Stolze's model first fits SLT into one of the 4 broad translation types in terms of text formulation, each of which is then open to three different sets of criteria required by the 3 categories of translation product users. Thus the translation categories support a general model to be adapted and selected for each different text type. By comparison, House's model, in demonstrating its practicability, focuses on the distinction between two broad types of translation only, viz., *overt translation* and *covert translation*. But both take into consideration pragmatic functions related to different translation strategies as applied from a textological or typological point of view. On the other hand, House sticks to established global criteria for TQA governed by language functions, whereas Stolze emphasizes the importance of viewing both text and translation as a dynamic whole in selecting the assessment criteria according to different end-user perspectives and their holistic integration. It is therefore more prescriptive than interpretative as compared with the former which is a typical descriptive model.

As will be further propounded in this chapter, our model for film dialogue translation (see 4.2 next)

which can be labelled as one for FDT quality control and assessment is aimed at serving a dual-purpose function in terms of: (a) guiding the translation by the standards of FITness as to giving due treatment to all variables affecting the translation quality, not only the situational features of a given translation but also the translation initiator factor as well as the prospective client's needs involved, and (b) evaluating the finished product by comparing TT with ST in relation to an 'ideal translation' in a comprehensive manner with FITness as the key criterion. Hence the need of integrating the above TQA models for the purpose of the present study.

FITness in FDT

So far the working relationship between translation equivalence and quality evaluation in the context of film translation has been interpreted such that the desired TE as the goal and quality criteria for FDT can be subsumed under the heading of FITness which is derived from a medium-specific analysis of the overall 'equivalent effect' basic to a quality film translation product.

In enumerating different objectives of TQA, Sager (1989:97) points out that the most important one is

concerned with the evaluation of "the appropriateness for [a translation's] intended purpose" of "achieving the desired communicative effect". Appropriateness, as defined by Sager (id.:98), is embodied in four criteria: accuracy, intelligibility, functional adequacy and formal presentation. However, Sager has stated it explicitly that "we exclude literary translation since it is subject to different criteria and must therefore be evaluated differently." (id.:96) In furtherance of this theory towards specifying the criteria for evaluating literary translation, As-Safi & Ash-Sharifi (1997) highlights naturalness to be the conceptual word appropriate to literary translation that attains "a matching literary level to the original" (p. 60). The main features of naturalness are classified as grammaticality, acceptability, idiomaticity, authenticity and contemporaneity, all of which concur to produce the desired effect - intelligibility, accessibility or readability (ibid.).

Apart from the general principle of quality and evaluation standards, naturalness and FITness as embodiment of translation ideals also share some common properties in their specific criteria of achieving translation equivalence, for example,

idiomaticity and authenticity. However, translation equivalence is a variable that needs to be redefined in FDT. From the perspective of translating for the media, film translation distances itself from literary translation more evidently than the diversification of these two genres of translation would lead one to expect. This may be seen in the light of the unique status of FITness.

The concept of FITness is a genre-specific version of the notion *dynamic equivalence*, which is "the closest natural equivalent to the source-language message." (Nida 1964:166). It is interpreted in a hierarchy of dimensions: lexical, semantic, syntactic, stylistic, pragmatic and communicative. For a scene of verbal duel, "conflict" is the priority; a fun-prevailing, entertaining scene, "humorous" and "comic" are the effect to be after; a court scene must be rendered with oratorical clarity and assuming rigour of reasoning; and a literary and poetic drama must reflect the original beauty of the language and the subtlety of the lines and the art in delivering them, and so on. These instances of translation equivalence on the macro-level arrive at creating faithfully the general 'tone' of the scene or a speech act

sequence. On the micro-level and more importantly, maintaining the audio-visual information synchronization through new-information-prominent TL verbal representation is the overriding factor in achieving TE, or FITness, in FDT. From the point of view of the consumer, this is an effective way to make film dialogue translation carry both quality and conviction.

Levels of FITness

In conformity with the three general objectives that construe FIT, FITness is consequently realized in terms of *informativeness* (fact), *delusiveness* (illusion) and *cohesiveness* (textuality). Each of these salient features is the outcome of decision-making on attaining the desired translation equivalence on different levels of the film dialogue, viz., *semantic*, *syntactic*, *prosodic*, *idiomatic*, *sociolinguistic* and *organic*. They constitute two major dimensions of FITness, which can be understood in a set of correlated dichotomies from different perspectives (Figure 15).

In interpreting the six levels on which translation equivalence occurs linguistically, paradigmatically, stylistically and syntagmatically, it needs to be

iterated that our discussion on FITness is based on the premise that intonation unit is the constant UT of film dialogue; in other words, the word order agreement between FDs and FDt must be maintained in the form of equal increments of IUs.

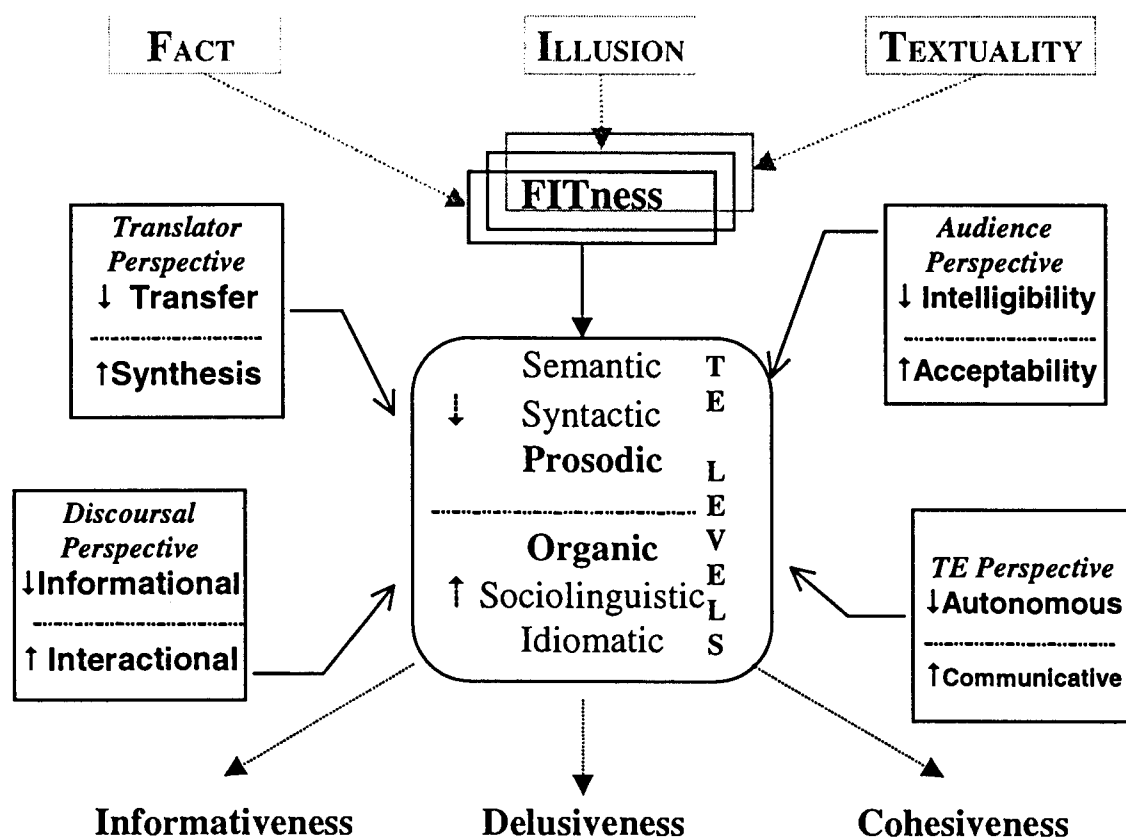

Figure 15

Aspects of FITness viewed in different perspectives

Anchoring at each designated IU in rendering the words as a sense group into TL, the translator has to weigh insightfully both the informational and interactional implications by means of taking the related two steps of transfer, which deals with

linguistic conversion, and synthesis, which organizes and polishes the initial TL codes into a natural flow of the overall discourse. To the audience the translator's performance in the first stage affects their basic understanding of the dialogue and the result from the latter stage determines whether the dialogue is perceived as an integral part of the movie or an unnatural representation of the characters' speech.

The relationship between these two stages of operation is homologous to that of text and context in discourse analysis. In fact, the equivalent language form and function in TL come hand in hand through the transferring and synthesizing process which distinguishes the local features of SL from the global ones while treating the original discourse as an organic whole. "A translator must therefore bear in mind both its autonomous and communicative aspects and a theory of equivalence should take both elements into account." (Bassnett 1991:29) The autonomous/communicative character in film dialogue discourse is reflected in two dimensions of a structural-contextual field for TE, each involving a hierarchy of parameters for consideration. The structural dimension consists of :

- (a) the *semantic* equivalence, which is gained at the lexical level with word-to-word, or, in the case of English-Chinese FDT, lexeme-to-lexeme, correspondence;
- (b) the *syntactic* equivalence, i.e., the tagmeme-to-tagmeme correspondence, or resemblance of the grammatical structure in that the same word/phrase order in TL as compared with SL is attained; and
- (c) the *prosodic* equivalence, the highest-level match in the first dimension, which sees that the TL item representing the new information be in equal position, timing and stress to those of the original and that, in some cases, most or the entire segment be in the similar rhythm and intonation contour to those of the original. The prosodic level must be distinguished from the phonological component, which is of little comparability potential in inter-lingual translation, with the exception for poetry translation.

Going beyond the formal conceptualization of the dialogue meaning, the contextual dimension attends to stylistic and pragmatic features, ensuring similar effect in natural, logical and artistic terms to be achieved in FDT. Carrying over from the last division, it also has three levels on which the translator seeks:

- (d) *idiomatic* equivalence, which is more than a grammatical and informative rendition as derived from the first dimension - it is concerned with the colloquial style and usage in the TL;
- (e) *sociolinguistic* equivalence, or authenticity, which defines the social status and identity of the speaker in terms of register as well as sociolectic and idiolectic features; and
- (f) *organic* equivalence, or cohesive equivalence, at the top level of the second dimension, which contextualizes the translation of the IU and establishes the parity of textuality between FDs and FDt, so that the translation of the segment fits appropriately into the sequence of IUs.

In each of the two dimensions, there is a hierarchy of priorities with the primary goal set at guaranteeing the equivalent effect on the top level, i.e., *prosodic* in the informational dimension and *organic* in the interactional one, among the other levels on which TE may or may not be present, even at the expense of closer approximation on some or all of these other levels. This is because our translation model is driven by FIT as the underlying principle that determines

that spoken language translation in the film medium must maintain the minimal functions of being informative, delusive and cohesive to represent the dialogue as it is intended in SL and expected in TL.

As a consequence of applying the FIT principle to our model to arrive at the functional equivalence on top of the formal equivalence, the translation process yields translations in coherent IU-based segments with various degrees of equivalent match. There are basically four types:

Type 1. Perfect match

This is the most ideal scenario, which is only incidental in the translation between two widely diversified languages like English and Chinese. Here is an example¹¹ from *The Silence of the Lambs* (Scene 29), spoken by Dr Lecter 'the Cannibal'. Comparing the Chinese translation with the original English segment, it matches tightly with each other in all respects judging against the 6 level criteria.

(1)

... People will say .. we're in love.

... Ren men yao shuo .l. wo men zai xiang ai .
People will say we are in love

(Back translation: People will say we are in love.)

In this intonation unit, each word or prepositional phrase in the original is rendered into the corresponding Chinese character or ci' (character combination, which is underlined) in exactly the same order and there is perfect match for the primary accent, which falls on the new information, and secondary accent, which falls on the accessible information in the first accent unit, between both languages. In a higher dimension, the translation sounds idiomatic in spoken Mandarin and natural from the speaker in his particular role at the particular moment and in the particular social context contrived. Lastly it fits in the speech act sequence in the last dialogue between Agent Starring and Lecter.

Type 2. Form-skewed match

This is the next-to-perfect match in that the equivalent effect is basically achieved on all levels except that there is only partial similitude in lexical meaning and/or syntactic structure between FDs and FDt. Although semantically and syntactically it is hard to match the original closely, the general rhythm and word order are inventively copied after the stressed words are set in position. The outcome is functional and desirable spoken TL with maximal formal

correspondence to SL. Here is an example from *Good Morning, Vietnam!* (1987), a scene in a Saigon saloon, where the army DJ Adrian Cronauer said to Jimmy Wah, the bar owner, half-jokingly at the end of their first bit of dialogue:

(2)

... You're a very sick ^^man.

... Ni ~ xiang dang ^^bian tai`.

you pretty pervert

(Back translation: You are an aberrant personality.)

This seemingly simple line would hardly make sense if translated literally into Chinese. So the predicative noun phrase is substituted with an adjective to be the subject complement. Even though it has lost full semantic and syntactic equivalence, it maintains the SVP order, similar length and the end-focus stress in Chinese. The utterance sounds idiomatic, equally sarcastic in function and has the same visual association to the audience.

Sometimes the semantic and syntactic substitution extends to the whole clause in order to retain the formal resemblance. The following are two dialogue segments from two scenes in the movie *Graduate* (1967) in conversations between Benjamin, a young college graduate (played by Dustin Hoffman), and

Mrs. Robinson, one of his parents' oldest friends. The first line refers to what Ben has said earlier about Mrs. Robinson trying to seduce him.

(3)

... It's the ^{^^}worst thing I've ever [^]said to anyone.

... *Zhe`shi` ^{^^}zui`bu`hao`de`hua` | wo`bu`gai` [^]shuo`de.*

this is worst word I shouldn't say ASP

(Back translation: This is the worst words I shouldn't have said.)

Here, if the attributive clause I've ever said to anyone is translate as such into Chinese (*wo` suo` shuo`guo`de`*), it must be put in front of *zui`bu`hao`de`hua`* (the worst words) to be acceptable to the audience. But it would devastate the original pattern of information flow and still sound unnatural. As a matter of fact, this difference in the position of relative clause in relation to the noun phrase it modifies poses one of the major problems in translation between English and Chinese, especially in spoken language translation where an inverted word order in TL is considered the last strategy. Substituting the clause with an 'afterthought' or a similar functional element to maintain the original word order, though with some loss of meaning, seems to be a good solution.

The next example consists of two consecutive IUs, also said by Ben to Mrs. Robinson about dating her daughter, Elaine.

(4)

(1)... I'm not ^{^^}good enough for her to [^]associate with | am [^]I?

... *Wo ~ bu ^pei` he`ta` ^jiao`wang` | ^shi`ma?*
I not deserve with her associate right Q¹²

(Back translation: I don't deserve to associate with her, is it?)

(2)... I'm not good [^]enough to even ^{^^}talk about her | am [^]I?

... *Wo`shen`zhi` ^bu`pei` ^^tan`qi` ta`|^shi`ma?*
I even not deserve mention her right Q

(Back translation: I don't even deserve to mention her, is it?)

Both IUs in Chinese preserve the basic syntactic and prosodic features in English, with only a few lexical items chosen to use analogously, e.g., *bu`pei`* (not deserve) for not good enough and *shi`ma* (the general 'is it') for **am I**, and one case of dislocation on the syntactic level, i.e., the position of *shen`zhi`* (even). Apart from these discrepancies, the whole rendition duplicates the original both formally and functionally.

Type 3. Function-skewed match

Owing to great differences between English and Chinese in language and culture, full formal correspondence in translation is a luxury that comes by only by coincidence. However, the film translator, by exercising his/her creativity, can

establish the closest possible relationship between SL and TL indicated by similar formal and functional features, since every language (culture) is rich in its own indefinable ways to make it possible. Realistically, it is the functional equivalence that the translator is after. In most cases, semantic, syntactic and (part of) prosodic equivalence must give way to meeting the other macro-level criteria in order to produce stylistically and sociolinguistically appropriate translations. But since such higher-level match operates in parallel to the original informational structure, it demands an approximate equivalent to the information focus to be juxtaposed in TL so that the translation still bears resemblance to the basic formal framework of the original.

From *Sabrina* (the 1995 remake), we get Examples (5) and (6) from a dialogue between a chauffeur and his daughter Sabrina. The father is concerned about Sabrina's obsession with the handsome son of his employer, David, as she spends an inordinate amount of time sitting up in a tree spying on him.

(5)

(1) ... You've spent ^more time up in that ^^tree

... *Ni ~ hua ~ ^tai duo de shi jian ~ zai ~ ^^shu shang*
 you spend too much time in tree LOC

(2) .. than you have on solid ^^ground.

...ying ^ˊgai ^ˊhui ^ˊdao ^ˋ ^ˋxian ^ˋshi ^ˋ
should return to reality

(Back translation: You've spent too much time in the tree when you should come back to the reality.)

(6)

(1)... There's much ^ˋmore to you

... Sheng ^ˋhuo ^ˋdui ^ˋni ^ˋ ^ˋyuan ^ˋbu ^ˋzhi ^ˋ
life to you far more than

(2).. than this ^ˋobsession.

.. zhi ^ˋchen ^ˋmi ^ˋ ^ˋhuan ^ˋxiang ^ˋ
just indulge in illusion

(Back translation: Life to you is far more than indulging in fantasy.)

The translations of both IUs delivered by the father have achieved the TE on the prosodic level and all the interactional levels, since the Chinese segments are faithful to the original in that they are timed with the exact information foci, idiomatic, suitable for a father's advice in that particular situation spoken by a man of means (it turns out later that the chauffeur is a multimillionaire in disguise) and in harmony with the adjoining utterance. However, the formal correspondence at the semantic and syntactic levels are sacrificed for the functional effect; otherwise they would have sounded either unintelligible or unidiomatic. For example, the metaphoric use of **on solid ground** has to lose its pun in translating into Chinese because none of the available choices

of literal rendition, *hui`dao`di`shang* (back to ground), *xia`dao`shi`di`* (down to solid ground), *jiao`ta`shi`di`* (stand on solid ground), etc. fits in with the context. On the other hand, the **There be** structure and the comparative clause (**more**)... **than**... have to be rearranged into different patterns in Chinese in order to make sense and sound natural to the ear. The latter phenomenon actually poses another translatability problem in the context of SL-oriented translation, because the comparative structure expressed in Chinese, ... *bi`... geng`...* (...than... more...), is just the inverse of the English version.

Type 4. Minimal match

As a matter of principle, priority is given to prosodic and organic equivalence in all cases, which means, to meet the minimal criteria for equivalent effect, at least each these two parameters topping the two FITness dimensions must be adequately taken into consideration. This is especially important in cases of dealing with colloquial usage of language including translating idioms, slang expressions, phrasal words, aphoristic sayings and culture-specific allusions. Here are two examples that involve brain-racking

rumination in spite of their simplicity. The first one is taken from the first scene of *Speed* (1995) uttered by the cold-blood killer as he was stabbing a security guard to death with a dagger.

(7)

... Nothing ^^personal

...He ǎni ǎǎmei ʻchou ʻ

with you no enmity

(Back translation: No malicious feelings about you.)

This is by no means the best option by the standards of idiomaticity and authenticity, which would have led to some set expression; the favoured cliché would be the most likely one in such a situation:

... ^^Bu hao ǎyi ʻsi

It's embarrassing. (Sorry.)

Although it fits in with the brutality of the scoundrel and is far more natural than the more 'faithful' translations such as *Mei ʻge ren ʻen ʻyuan ʻ* (No personal feelings), *Bu ʻshi ʻsi ʻchou ʻ* (It's not personal rancour) or *Fei ʻge ren ʻyuan ʻyin ʻ* (Not for personal reasons), none of these translations can be compared to the version chosen in (7), which creates both the prosodic and communicative effect.

The second example is a case of how to put a simple utterance into a Chinese equivalent that has to abandon formal likeness to the source in order to

sound appropriate without losing the information focus and textuality in the speech event. This is from the film *How to Make an American Quilt* (1995). In a swimming-pool, Hy, Finn's grandmother (played by Ellen Burstyn), being splashed all over by a boy who has just dived in, shouts out,

(8)

... **That's not** ^{^^}allowed!

... Bu`yao` ^{^^}hu`lai`
 don't make trouble

(Back translation: Don't make trouble!)

The reasons for putting this four-syllable utterance into such a linguistically diverse phrase are obviously accountable from the pragmatic point of view. Other options of equal length could be:

(a) ... Na`yang` ^{^^}bu`xing`
 that not allowed

(b) ... Jin`zhi` ^{^^}na`yang`
 forbid that

(c) ... Bu`neng` ^{^^}zhei`yang`
 can't like this

(d) ... Bu`xu` ^{^^}dao`luan`
 not allowed make trouble

Options (a) and (b), influenced by the deictic reference **that** in English, do not represent the spontaneous reaction of a native speaker of Chinese in a similar speech situation, although they are faithful on the semantic level and, for

(a), on the syntactic level as well. Option (c) sounds rigid too, because a person like Hy, then and there, would not keep down her annoyance and nervousness by speaking in a far less authoritative manner than what and how is actually said. Perhaps the second best choice is (d), as it lays similarly timed stress to convey the meaning of **not allowed** and is naturally-sounding in the circumstances, except for its lesser equivalence achieved on the prosodic level in comparison with (8), where the lip-synch effect is ideally realized in that the utterance ends with a descending diphthong in both English (/au/) and Chinese (/ai/).

For all the above reasons to the contrary, the translation in (8) is the optimal version out of the 'minimal match' situation.

Delimiting the description of the ideal translation quality¹³ to the four types of desirable FITness status as a result of the interplay of the parameters up and down the different levels has implications for the feasibility and viability of our model for FDT, the fundamental principle of which is sticking to IU as the unit of translation and maintaining juxtaposed NI focus throughout the translation process. However, the four match types

should not be viewed as clear-cut divisions but as interrelated and overlapping categories along a continuum on which equivalence to form and function is achieved in varying degrees.

To have a better understanding of how these types distribute over a continuous stretch of discourse in terms of relative frequency of occurrence, Example (9) below, again taken from *Sabrina* (1995), suggests that translation strategies in FDT can be centred around these four combinations of equivalent elements. It shows more clearly the meaning of organic equivalence that guarantees coherence between IUs and between larger units.

It takes place in a scene where Linus and David have an argument. David comes barging into his older brother Linus's office extremely angry that his brother is trying to make financial gain from his wedding plans. David accuses Linus of setting the whole thing up, but Linus counters that David himself asked him to make David look good in front of his fiancée. David expresses doubts about whether he is ready for marriage. Linus tells him he should grow up and be an adult. Illustrated here is only the part that is towards the end of the dialogue when Linus gives David a lecture.

First the selected original dialogue segment is shown as a whole (using // to mark off the IUs) , then juxtaposed to its Chinese translation one IU per line with the syllable counts compared with each other, as well as the match category assessed alongside.

(9)

Linus: I pay for your life, David. //My life makes your life possible.//

David: I resent that.//

Linus: So do I.// David, Look at yourself.// You went to Law School,// you never took the bar.// You went to business school,// I can't get you anywhere near the office.// You studied languages// you don't speak,// instruments// you don't play.// You have a series of girlfriends// you never see more than twice.// Do you not see a pattern here?// (16 IUs)

(from Scene: 'Two Brothers Argue', *Sabrina* 1995)

L: (1) ... I ^pay for your ^life, David. (7 syllables)

Shi`Wo`~^^yang`zhe`~^ni`~,Da`wei` (7 syllables) [Type 3]

be I sustain you David

(Back translation: It's me who support you, David)

(2) ... ^^My life makes ^^your life possible.¹⁴ (8 syllables)

... ^^Wo`~huo`de`hao`~^^ni`cai`bu`chou`chi`. (8.5 syllables)¹⁵[Type 4]

I live well you only not worry food

(Back translation: Only if I fare well can you be well-fed.)

D: .. I ^^resent that. (4 syllables)

.. Wo`^^fan` tou`le`zhe`yang` . (5.5 syllables) [Type 2]

I hate enough ASP this

(Back translation: I've had enough.)

L: (1) ... So do ^^I. (3 syllables)

- ... *Wo^ˋ ˋˋye^ˋshi^ˋ* (3 syllables) [Type 4]
 I too be
 (Back translation: I am also.)
- (2) ... David, ˋˋlook at yourself. (6 syllables)
- ... *Da^ˋwei^ˋ; ˋˋkan^ˋkan^ˋ ni^ˋzi^ˋji^ˋ* (6.5 syllables) [Type 1]
 David look yourself
 (Back translation: David, look at yourself.)
- (3)... You went to ˋˋLaw School, (5 syllables)
- Ni^ˋdu^ˋle ˋˋfa^ˋlü^ˋ*, (5 syllables) [Type 2]
 you studyASP law
 (Back translation: You studied law.)
- (4).. you ˋnever took the ˋˋbar. (6 syllables)
- .. *que^ˋ ˋˋcong^ˋbu^ˋ ˋˋzhi^ˋye^ˋ* (5 syllables) [Type 3]
 but never practice
 (Back translation: But never practice.)
- (5)... You went to ˋˋbusiness school, (7 syllables)
- ... *Ni^ˋshang^ˋguo^ˋ ˋˋshang^ˋxiao^ˋ* (5 syllables) [Type 2]
 you go ASP business school
 (Back translation: You went to business school.)
- (6).. I can't get you ˋanywhere near the ˋˋoffice. (11 syllables)
- .. *wo^ˋcong^ˋbu^ˋjian^ˋ ni^ˋzou^ˋjin^ˋ ˋˋxie^ˋzi^ˋlou^ˋ* (10 syllables) [Type 3]
 I never see you walk into office building
 (Back translation: I never see you walk into the office building.)
- (7)... You studied ˋˋlanguages, (6 syllables)
- ... *Ni^ˋxue^ˋle ˋˋwai^ˋyu^ˋ,* (5 syllables) [Type 1]
 you study ASP foreign languages
 (Back translation: You studied foreign languages.)
- (8)..you don't ˋˋspeak. (3 syllables)
- .. *you^ˋ bu^ˋhui^ˋ ˋˋjiang^ˋ* (4 syllables) [Type 2]
 yet not able to speak
 (Back translation: but don't speak.)

- (9) ... ^{^^}instruments (3 syllables)
 ... *mai 7e ^yue `qi `* (4 syllables) [Type 2]
 buy ASP instruments
 (Back translation: You bought instruments.)
- (10) ..you don't ^{^^}play. (3 syllables)
 .. *hai `bu `hui ` ^wan `r.* (4 syllables) [Type 2]
 still not able to play
 (Back translation: but can't play.)
- (11)... You have a [^]series of ^{^^}girlfriends (8 syllables)
 ... *Ni 7yi 7ge 7yi 7ge `de ^huan ` ^^nu 7peng 7you* (9 syllables) [Type 3]
 you one by one change girl friends
 (Back translation: You changed girlfriends one after another.)
- (12).. you [^]never see more than ^{^^}twice. (7 syllables)
 .. *mei 7ge 7jian 7mian 7bu 7chao 7guo ` ^liang 7ci* (8.5 syllables) [Type 3]
 every meet not exceed twice
 (Back translation: You see each of them no more than twice.)
- (13)... Do you not see a ^{^^}pattern here? (8 syllables)
 ... *Ni 7kan 7bu 7chu 7ni 7you 7^wen 7ti 7ma?* (8.5 syllables) [Type 3]
 You see not ASP you have problem Q
 (Back translation: Don't you see you have a problem?)

From this example we are informed of what probably happens in actual translation operations as to what percentage of each type of translation strategy is in use, if the same translation methodology as ours is applied. As it shows, of 16 IUs translated into Chinese, 75% of them belong to Types 2 and 3 situations with 37.5% to each category; whereas, in contrast, Types 1 and 4 together make up 25% of the total (occurring in 12.5% respectively). On the other hand, we see no consistent correlation between the syllable count difference (sameness) of

a FDt segment as compared with the FDs and the pertinent match type the translation is identified with. But significant as it were is the result that the discrepancy in the number of syllables between FDs and FDt in all segments never exceeds 1.5 syllables, hence a potentially close lip-sync effect in dubbing. These initial findings still need further verification; however, it does demonstrate the effectiveness of our IU-centred FITness-targeted translation approach, the principle of which applies equally well to dubbing and subtitling as will be considered in Chapter 6.

4.1.5 Summary

Our discussion above of the most-debated topics for translation in general and dubbing in particular in the information flow perspective has shown its theoretical consequences on these focal areas of primary concern in TS and clarified the guiding principle of FDT. The IF theory as applied in developing our model for FDT has so far provided a powerful foundation on which the solutions to those conceptual perplexities addressed above have been initially justified and a methodology for FDT with special reference to English-to-Chinese dubbing using our model is to be defined and refined next.

4.2 Presentation of the Model

The methodology adopted for testifying the validity of our model for guiding the translation process and evaluating the translation product can be briefly described as FIT-bound, NI-sync and A-T-S schematized, which are summoned to dub this model **FITNIATS**. It is intended to be pragmatic and multi-functional, encompassing operative, descriptive, comparative and evaluative dimensions. Although the FITNIATS model is fit for both dubbing and subtitling, the following discussion and the ensuing application of the model will dwell on dubbing. This provides the most appropriate basis for the demonstration of the capabilities of the model, since translating for dubbing, unlike subtitling, is meant to create a full substitute for the original and, in the English-to-Chinese FDT context, the quality of subtitles, which are parasitic on a dubbing script, depends on the improvement of its base.

4.2.1 The FITNIATS Model

For human dubbing-targeted translation, it is impossible to prescribe lists of translation tasks with a yes/no option in a non-negotiable system set up by a water-tight flowchart, although the day will come when MT takes over the whole business.

Translating for dubbing is a highly creative speech art that demands the human faculty to manipulate dynamic expression and cultural subtlety across two different languages resourcefully. Therefore, the present model does not intend to formalize the translation process by stipulating rules by which certain grammatical constituents should be accordingly isolated from the text for translation, or by which translating FD must proceed rigidly along the stages demarcated in an assembly line manner. What is being proposed is a new way of thinking on practical matters concerning a standard procedure which offers more direction and efficiency to dubbing translation and also for quality-assessing purposes. It is accommodated in the framework of A-T-S, the three major stages in the setting of MT; and centres on the new information transfer at the level of IU (Figure 16).

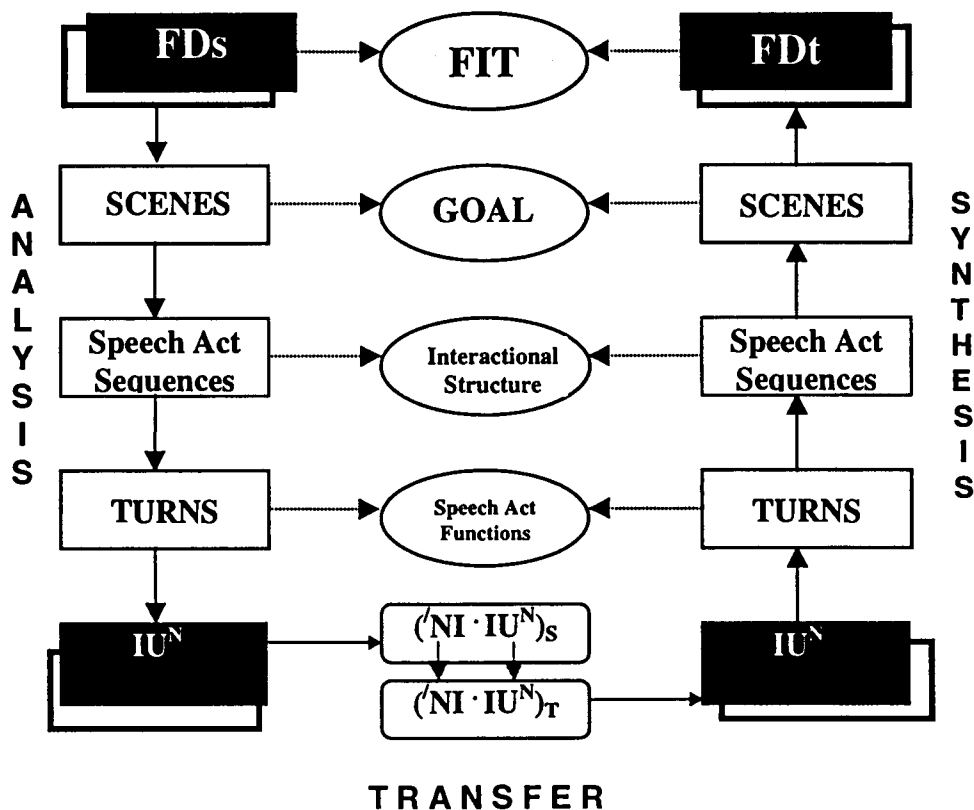

IU = intonation unit
 IU^N = intonation units
 'NI = new information with primary accent
 ('NI · IU^N) = locate and synchronize the one new idea in each IU_S with that in IU_T

(~)_S = in SL
 (~)_T = in TL

Figure 16

An FIT-bound, NI-sync A-T-S model for dubbing (FITNIATS)

The Analysis module as an essential component of FITNIATS is a top-down process of anatomy applied to the original FD and, in the case of the assessing translation quality, carried out in comparison with FD_t. It examines both the structural (textual) and contextual aspects of FDs, focusing on speech act sequence recognition (dialogue paragraphing), speech act functions (designations of adjacency pairs) and the

identification of intonation units (segmentation and given/new information location). Transfer, or the initial rendering, takes place at the micro level where each segment of information in FDs is translated into the TL by the IU according to the principle of equivalent effect, which is subject to modification on the interactional levels to result in one of the four broad types of match (Cf. 4.1.4.2;). The Synthesis stage is a bottom-up process following the translation of the IU and focusing on achieving cohesion and coherence between the IUs and its upper levels. Idiomaticity and sociolinguistic features of the translation are also the main concerns. Formal and functional translation equivalence is aimed at every corresponding level between FDs and FDt. The ultimate product is ideally a coequal of FIT with the original. In practice, the special treatment to qualify FDt to be either a dubbed or subtitled version is carried out in the course of the synthesis.

4.2.2 The Data

I chose an imported TV mini-series¹⁶ from America (coded **FDs** in the analysis) and its dubbed version (code **FDt1**) to be the data for attesting the applicability of my film translation model. It is

the 1991 Emmy Award nominee *A Woman Named Jackie* (directed by Larry Peerce; **Jackie** for short). *Jackie* was dubbed and subtitled into Chinese (Mandarin) for viewing on TV all over China by the translation team of Guangdong Television (GDTV) in Guangzhou (Chinese title *Zong`tong` Fu`ren*, produced in 1993). My translation for dubbing of the relevant scenes in *Jackie* (coded **FDt2**), which is the result of the application of the translation approach proposed in this thesis, will be used to compare with the GDTV translation.

The rationales for selecting this film and its translations for my FDT studies are:

- (1) it represents the state-of-the-art dubbing for cinema and television in China, because it is the product of a leading Chinese television station, the only one in the whole country that had its own professional film translation team¹⁷ and the translation was done by a senior professional translator working in the field of film translation (job title: *jiao`yi`*, or translation editor);
- (2) it was released in videotapes (VCDs) and transmitted for public viewing on TV, so that the data sources for FDs and FDt1 are available to be transcribed into dialogue

scripts which are accurate as to what is heard on the screen for our research purposes;

- (3) dialogue plays a substantial role throughout this teleplay and the original dialogue is well-composed and authentic-sounding; and
- (4) my translation of the teleplay to represent the improved dubbed version is the outcome of employing the new methodology initiated in this study which has been tested as consistently valid and reliable under the FIT theory and in comparison with the original dialogue and the broadcast translation throughout the experimentation I carried out on the entire teleplay.

4.2.3 Description of the Method

In the first part of this chapter, we have examined four interrelated issues vital to FDT, including dimensions of information flow, grounds for foreignizing film translation and its reliance on prosody and word order, unit of translation and FITness in film translation and quality evaluation. The FITNIATS model has attempted to incorporate all these considerations into the theoretical system derived from functional linguistics and made special to English-Chinese dubbing for purposes of

maximizing the original power of FIT in the FDT and describing/assessing the translation quality of the dubbing products.

The methodology is basically qualitative while supported by statistical evidence. Through this case study on the film by means of parallel text analyses and problem-solving demonstrations with the provision of a 'favourable' translation intended by myself, I will testify the inadequacy and limitation of the traditional sentence-based film translation approach against the soundness and viability of the IU-based model that can lead to superior quality film translation for dubbing in terms of arriving at functional and communicative equivalence. In each of the samples for analysis from the film translation data mentioned above, I have tallied the instances of observance and violation to the constraints on FDT in general, and the principles of FIT in particular, to certify the cause of common problems found in English-Chinese dubbed films. The steps are taken along the sequence of three self-contained translation/evaluation modules of A-T-S, which nevertheless do not represent an unintegrated linear process of passing detached components of a binary system one after another. The central link, the transfer

module, conjoins the two reverse processes of analysis and synthesis into a correlative and interpretative composite.

4.2.3.1 Analysis of FDs

The analysis of the original film dialogue is to establish the base of the translation and evaluation process. As an integral component of the FITNIATS model, it sets out to examine the discourse structure of FDs from top down with the eventual result of breaking it up into IUs against a clear, meaningful context prior to the transfer stage. The analysis module, consisting of structural (textual) and contextual dimensions in itself, represents the infrastructure of the model.

The structural analysis of FDs combined with the contextual analysis proceeds basically within the confines of the first phase of the tripartite process, focusing on different tiers of the dialogue organization from the scene, the speech act sequence, to the turn and the intonation unit, to interpret the textuality and information structure of FDs at both formal and functional levels. Through the structural analysis, the linguistic and extra-linguistic characteristics of the dialogue are to be identified; however, the

description of its informational and interactional aspects is not complete without viewing it in a full context which also includes the stylistic, socio-cultural and pragmatic features of FDs.

1. Scene

The analysis of FDs is done scene by scene; the theme or the goal of each scene is first identified, which sets the general tone of the scene and serves as an index for the translator's working agenda.

2. Speech Act Sequence

Within each scene there may be one or more speech act sequences. Speech act sequence (**SAS**) in this context is defined as the basic unit of the interactional structure of FD that indicates the sequential organization of the discourse in terms of speech act grouping or the topic flow. The boundary marker for SAS is indicated by the end of a group of related utterances centring around the same subject or serving thematically connected speech act functions and the beginning of the next group. For practical purposes, we refer to the components of these groups indiscriminately as *adjacency pairs* of different types.

SAS comprises two major types: *Autonomous Adjacency Pair (AAP)* and *Consecutive Adjacency Pair (CAP)*. As illustrated below, the former initiates a new topic or an independent speech act and, unlike the latter, it can stand alone or take a CAP, which always ties to the previous adjacency pair(s) or non-verbal information:

Autonomous Adjacency Pair

Gittes: **I found these in your backyard — in your fish pond. They belong to your husband, didn't they?... didn't they?**

Evelyn: **I don't know. I mean yes, probably.**

(*Chinatown* 1974)

Consecutive Adjacency Pair

Paul: **Are you scared?**

Jeanne: **No, not anymore. Not now ... let me go. I'll come back.**

(*Last Tango in Paris* 1972)

The anaphoric referents *anymore*, *now* and *back* are clues of the CAP's dependency on the previous message.

CAP can be either *active (CAP_A)* or *passive (CAP_P)*. CAP_A is self-initiated whereas CAP_P is formed as a result of Person A's contradiction, challenge or refusal which takes over the last speech act to put Person B (in the role of the hearer when making the last remark) into the next speaker role. Both AAP and CAP can be either *Terminated Adjacency Pair*

(**TAP**) or *Unsettled Adjacency Pair* (**UAP**). For example,

Person A (Speaker): But is she still interested?	>	CAP_A ; TAP
Person B (Hearer): Yes, she is ... all along.		
↓ ↓		
[(Speaker): Yes, she is ... all along.]	>	CAP_P ; UAP
Person A (Hearer): Oh, yeah?		

Generally speaking, within a scene, film dialogue consists of more CAPs and UAPs than AAPs and TAPs; and more often than not, the end of the scene finds UAP closing the dialogue with either a verbally countering utterance or a non-verbal (visual) response, which contradicts the last utterance or leaves it unresolved. Figure 17 shows the structure of SAS in our film dialogue analysis for translation:

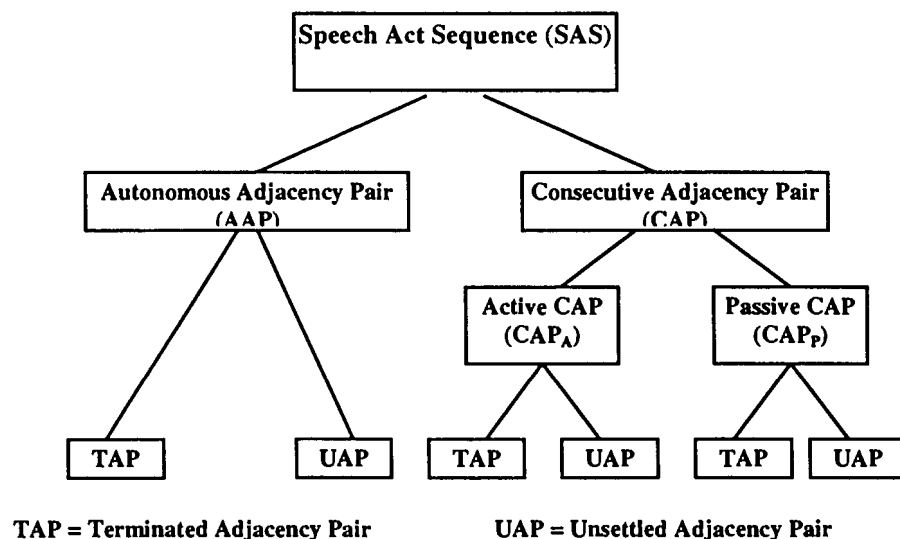

Figure 17

The basic binary structure of speech act sequence

Breaking film dialogue marked by a scene into SASS is conducive to a better understanding of the information flow at the macro-level of the FDs under translation for achieving functional equivalence of speech acts in FDt. It is a step leading to a more meaningful and purposeful segmentation of FDs into smaller units.

3. The Turn and speech act function

At a lower level of the discourse structure, there is the Turn. A turn is the speaker role being taken by an interlocutor during a conversation. In FD the turn-taking rule is generally more cooperatively observed by the dialogic parties. In most cases, a turn in FD represents one or more speech acts (or moves) which are cognitively more manageable than natural speech. The analysis of turns in FDs in relation to their speech act functions serves as a pragmatic focus for the ensuing translation on what the audience concerns first and foremost: what point does the character on screen try to make? But prior to the translation, units of information in a speech turn must be further processed.

4. Intonation Unit

FDs is then segmented into IU which is punctuated by the natural pause indicated in the speaker's turn auditorily and semantically. An IU is either an idea unit by itself or consists of more than one idea unit with a primary accent marked on the lexical item representing the new or accessible information. For our purposes, the new information in each IU is accentuated as the focal point for the next phase in our model, i.e. Transfer.

With the conclusion of the analysis, well-defined standards for the subsequent translation and its quality assessment are set up, which specify not only semantic, syntactic and prosodic measures, but also idiomatic, sociolinguistic and organic parameters. Carried out in one process, the two-dimensional analysis of FDs integrates all these considerations into the correlates of form and content, meaning and function, text and context.

4.2.3.2 The Translation Process of FDt2

The translation process should be understood as one that runs through the FITNIATS course from Analysis to Synthesis via Transfer which is the centre of the activity. Here we concentrate only on the latter two stages, assuming my translation of Jackie was conducted strictly in accordance of the

FITNIATS method, with a sound basis of the analysis done to start with and the special considerations and treatment given to the special mode of dubbing wherein the translation was eventually completed. In the course of implementing the model and the ensuing discussions, FDT2 stands for my intended dubbing-ready translation of *Jackie*. Providing FDT2 is an essential part of my study that is based on a criteria-defined and application-proven comparative methodology. The purpose of using such a translation as exemplification of the optimal solution to the problems detected in the parallel versions is not meant to demonstrate what *should* be done but what can be done with the FITNIATS model. It reveals the potentialities of this new functional approach to FDT for empowering English-to-Chinese film translators to be more efficient, creative and resourceful in their work.

1. Transcription and coding

Previous to the actual translation of FDs, the Analysis stage has narrowed its scrutiny down to the intonation units that compose the dialogue text, which, for pragmatic translation studies, must be either the continuity script provided with the release of the film¹⁸ or a verbatim text transcribed later from the actual dialogue

soundtrack¹⁹. In the case of this study, the full dialogue text (as distinguished from the samples shown in this thesis) is transcribed scene by scene with the character's name heading his/her speech turn. The texts are divided into SASs (marked at the end of each SAS) and finally segmented into the IUs (using slash "/" to separate IUs and a vertical bar "|" to separate accent units, and the primary stress symbol "'" and underline to mark out the New Information). The translation thus proceeds with a clearly analysed and coded transcript of FDs as the starting point.

2. Focusing on New Information

After the textual and contextual analysis of FDs, the translating task enters the second phase, Transfer. The semantic content of each IU is rendered into Chinese Mandarin in order of idea segments therein. Each idea unit is treated as a whole semantic entity, which is represented in the form of a word, a word combination, a phrase, or a group (a collocational expression or a colloquial idiom).

The focal point is the rendering of the lexical item which gives the new information in the IU. The information content overrides the correspon-

dence between the surface structures of the two languages, e.g., grammatical category; but, the timing and position of the NI in the IU are given the priority to ensure the closest approximation. Three secondary considerations hinge on this primary concern: the choice of the clause pattern, the adjustment of the word order and the naturalness of the entire IU in Chinese.

3. IUs into Turns

Assembling translated IUs into the Turn is the next step where the third phase Synthesis starts. Structurally, the same strategies as relevant to the syntactic arrangement of idea units apply. But the contextual adjustment based on the specified stylistic, socio-cultural and pragmatic factors can be decisive, because even if the structural correspondence is achieved at the Turn level, the same information can still be expressed in numerous different ways suggesting different nuances of speaker intent and role-relationship. To transfer the full speech act function(s) of the FDs turn faithfully into the FDt turn without losing the formal equivalence is the objective here. This is at the juncture of Transfer and Synthesis, a crucial part which requires most personal judgement, and this is where the FITNIATS model

makes the greatest qualitative difference between machine translation and human translation.

4. Keeping SAS in place

Speech Act Sequence marks the boundary of subdivisions next to the scene in FD discourse. The principle implemented here is to maintain the clear texture of FDs at the paragraph level in FDT. The structural equivalence can be automatically achieved if the lower level transfer and synthesis are made successfully; however, the interactional structure of FDT must show the full information content in each utterance with its in-situ speech act function delivered in an organic manner. The adjustment at this higher level of Synthesis to reflect appropriately the topic flow and change in style and mood, etc. as indicated in FDs is especially important in endowing FDT with desired cohesiveness.

5. Goal is achieved at the Scene

Bearing in mind that recapturing FIT functions in FDT is the overall aim of the FDT task, the translator should be more realistically orientated to attaining a succession of immediate goals by steps. The Scene is the appropriate macro working unit of a film for translation. Through my

analysis of *Jackie*, every scene is designated a sub-title which represents my understanding of the goal or the general topic of the scene. When the "knitting" of SASs has reached the end of a scene, a comprehensive check of this portion of FDt takes place in comparison of the corresponding part of FDs for "goal-matching". Both structural and contextual analytical criteria are called in to ensure the optimal equivalent effect is attained in informational and interactional dimensions of the scene.

6. End-user requirements and expectations

Finally, all translated dialogue parts in scenes are put to test in the film as a whole to avoid any uncalled-for stylistic inconsistency, dramatic incongruity and information inadequacy. In the final analysis, it is the translation product user - be it the targeted audience of the film or the "translation initiator" (Hewson & Martin 1991) - who has the authority to judge the quality of the translation from a pragmatic point of view. Their perspectives of a successful translation should be taken as the ultimate objective of the whole translation task, from the FDt script formulation to the finished dubbed version.

Table 6 below maps out a summary of the basic working procedures I took in translating the film, beyond which extra steps are to be taken to meet the specific technical demands of dubbing. The same transcription conventions are used for all the data samples in this study.

STEP	TASK	PURPOSE	TRANSCRIPTION CONVENTION	INSTRUMENTS
A	Transcribe FDs verbatim and divide the script in parts → acts → scenes → speech turns and mark them in order	To have a macro-view of the organization of the film as discourse and to make FDs manageable	Identify the name of the film in one word and number each scene as Film name:Sc. part-act.scene in Arabic numerals and use an initial in front of the IU number to indicate a particular character's speech turn, e.g., Lamb: Sc. 1-2.7, L (1)...., meaning the first IU in Lecter H.'s turn in Scene 7, etc.	
B	Identify idea groups and segment them into IUs and accent units	To break down FDs into units of information	Using three dots to indicate a longer pause and two dots a shorter pause between IUs and a horizontal bar to separate <i>accent units</i> within an IU; each IU is numbered (in brackets) and takes a new line	Chafe's system (1993)
C	Locate the NI in each IU and mark it with primary accent and mark accessible information in each accent unit with either primary or secondary accent	To highlight the information focus of each IU and the information of secondary importance	Using ^^ to show the NI with primary accent and ^ in front of accessible information with secondary accent	Chafe's system (1993)
D	After the scene-by-scene analysis of FDs (detailed in 4.2.3.1). Transfer the information into Chinese, IU by IU with NI in sync with the original	To achieve the optimum effect of simultaneous information delivery to match the visual and the formal resemblance of the original spoken language features	The ^^ and ^ are used as in FDs, but in Chinese the actual stress is realized through change of duration rather than that of intensity and pitch on F ₀ .	The correlational model of equivalence for English tone types (according to Halliday 1994: 302-307; 1970: 2.1-4.3) and stress system in Mandarin Chinese (3.2.3.5 of this thesis)
E	Check the coherence of the translation between IUs and at the levels of speech turns and SASs in terms of speech act function and cohesiveness	To synthesize the information chunks into naturally-expressed speech turns and SASs which are functionally equal to the original and stylistically appropriate along the foreignizing-domesticating continuum of translation strategies (Hatim 1996)		the FITness criteria and the SAS classification (this thesis); parameters in Halliday's schema of speech functions and responses (Halliday 1994:69)
F	Examine the connection and transition of FDt in the order of scene → act → part → film, to make necessary adjustment and modification	To strike the desired balance between the micro-unit and macro-unit harmony of the film as discourse		The FIT principle; The bottom-up approach to translation for discourse textuality (Baker 1992)

Table 6

Dubbing-oriented translation procedures under the FITNIATS model

4.2.3.3 Comparison, Evaluation and Discussion of the Findings

The Analysis of FDs as a result of implementing the FITNIATS model provides a metalinguistic representation of the original against which the translation quality of FDT is assessed. In this study, FDT1 and FDT2 are also compared with each other side by side. The triangular comparisons of FDs and FDT texts and between FDT1 and FDT2 are made simultaneously, with the installation of FDT2 serving two purposes: (a) to use it as an ideal translation, which can be defined in this context as a concrete illustration of the evaluation criteria specified from the analysis of FDs, to facilitate assessing the quality of FDT1 and, (b) to testify that FDT2 is a desirable improvement on FDT1, or an effective solution to its translation problems, which in virtuality serve as a foil to the high quality standard of FDT2, hence further proof of the validity of the FITNIATS model.

The study of the translation data is carried out SAS by SAS within the confines of a scene which is managed as the independent working division next to the whole teleplay for this research. The comparison within each SAS is Turn-paced, because the turn is the smallest comparable segment that

appear in the same order and consist of an equal number in both FDt1 and FDt2. Within each turn, intonation units are separated and numbered for FDs and FDt2. IUs are detected according to the segmentation method concerning the discernible pauses and the tonic syllable (Chafe 1993) and itemized one after another²⁰.

In the next Chapter, three samples representing three scenes from three different parts of *Jackie* and FDt are selected to show the analytical process of the case study. Following the comparisons at the end of each SAS and each sample (scene), a summary based on quantitative evidence are produced to analyse the problems found in FDt1 that are in violation of and incompatibility with the principles set by our model. Key statistical results (IU-, turn-, SAS- or scene-based) with respect to FDt1 include:

- Number of syllables in FDt in comparison with that in FDs;
- Number and percentage of NI Dislocations and misidentifications;
- Instances of causes for dislocating the NI: either the *motivated* type including TL-oriented poor style and the unnecessary marked structure, or the *constrained* type including poor solutions to problems of syntactic, idiomatic or cultural translatability.

- Number and types of mistranslations of information (wrong, partially misrepresented or inappropriate, or totally missing): *linguistic, stylistic, pragmatic* (speech act function, inter-actional structure, coherence), etc.

Samples are randomly selected to represent the results of our experimentation with the FITNIATS model. The overall outcome from the application of the model to FDt1 in its entirety is discussed, and a general statement of translation quality of FDt1 and FDt2 is finally drawn from the analysis and comparison of the source text and translation texts at the end of the chapter. In focusing on the mismatches identified in FDt1 by the FITness standards with statistical backup, the discussion aims at taking a balanced, non-subjective view of FDt1 text and interpreting them in the perspective of the product users.

4.2.4 Validity of the Model

As described above, the FITNIATS translation model I have proposed can be used to serve dual purposes: (1) to guide and facilitate the translation process of a film for dubbing (subtitling) by taking the goal-specified, priority-oriented steps; and (2) to evaluate a dubbing (subtitling) product in comparison with the source text by measuring the quality of the actual transfer of the information

segments and the focus in each of them against the translation goals established by the model in terms of communicatively equivalent effect. The implementation of the quality assessment criteria is fulfilled and interpreted mainly through observing the formal and functional mismatches between FDs and FDt at various levels of the dialogue discourse structure and in various TE-targeted dimensions.

The schematic structure of the "two-in-one" organization that features the methodology employed in this thesis is represented by the following sketch (Figure 18), which shows that both processes of the translation and quality assessment of a film can be integrated and built into the same model.

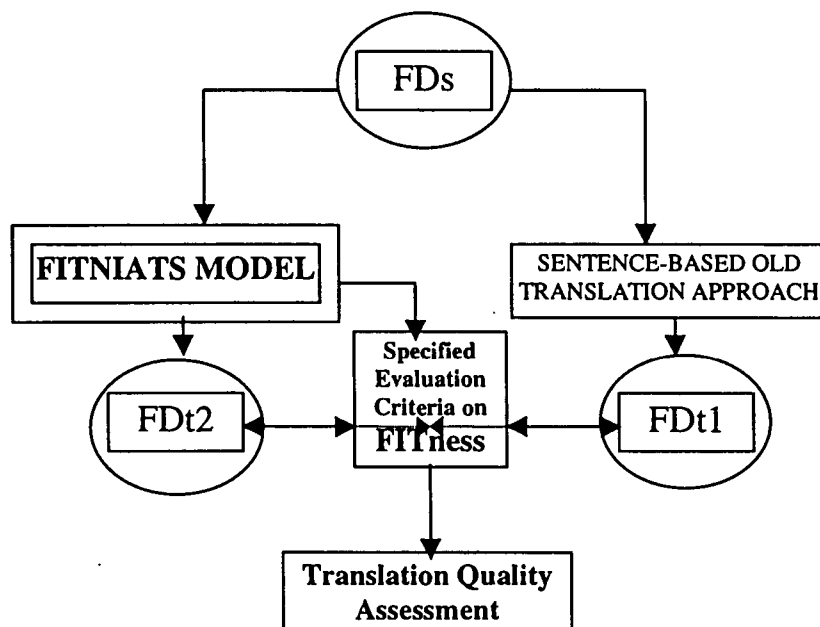

Figure 18
Process of the case studies testifying the dual functions of the FITNIATS model

The translation quality of both target texts can be stated on a solid ground with convincing evidence from applying the well-defined and contextualized assessment criteria; while the comparison between the two target language texts (FDt1 and FDt2) adds an extra dimension to the reliability of the model. The centrality of the FITness standards and the superiority of the FDt2 construe the validity of the model in optimizing and managing film translation process and product, the relationship of which can be stated as such that a theoretically and pragmatically justified translation approach ensures a sound scientific process that leads to a high quality product; in turn, the quality of the product verifies the effectiveness of the approach to a translation process.

In closing, the main purpose of this study is to establish a new methodology for dubbing, which is potentially applicable to subtitling as well. It is pragmatic and adaptable in approach in that translation quality assessment is preferred to be a tool more to the effect of quality control of the translator's own work than critic's evaluation of the finished product for academic purposes. The overwhelming message of the FITNIATS model is to

view translation more as a process than a product. The methodology involved is therefore dynamic and context-dependent rather than rule-governed and prescriptive.

Chapter 4

NOTES

1. See Levinson 1983 regarding the identification of speech acts.

2. The transcription conventions in the examples are also chosen to be the system for the analysis of the main data and will be explained later in this chapter. Note the following abbreviations in the word-for-word translation of the dialogue into Chinese: **MSR** = measure word and **LOC** = locational suffix on nouns in collocation with a preposition.

3. European Conference on Artificial Intelligence

4. In most cases, speech event is structurally equivalent to a dramatic event which constitutes a play scene. Although a scene in a film may involve more than one play scene, our analysis of film dialogue deems this difference negligible for reasons self-explanatory.

5. Take for example, compared with the practice in mainland China, dialogue in Hong Kong movie, which is generally more lively and attractive because it does not go with the talking heads, but has the visuals show different images when voice is heard.

6. As detailed in Li (1987:59).

7. Generally outlined are three basic functions that dialogue: (1) moves the plot forward, (2)

reveals characterization, and (3) provides information and exposition.

8. An example of such successful experiments is the IBM television commercial which uses the opening scenes of the American musical *The Sound of Music* to dub a dialogue in the mouths of the convent sisters on the topic of superiority of the computer product.

9. For instance, a television comic show called *Peiyin* (Dubbing) consists mainly of a videotaped mini-drama in three dubbed versions, each with a dialogue of totally different content. As they were presented in succession, the same performance turned out to be three totally different stories (Broadcast on China Central Television -Channel 1, on 19th April 1994).

10. The distinction between macro- and micro-evaluation is made by Sager (1989:97).

11. This example and all the ensuing ones in this section are assumed to be translations of desired quality. All of them are translated by myself as a result of using the FITNIATS model, which is detailed in 4.2 of this thesis. The Scene number identifies with the dialogue script of the original soundtrack transcribed by me.

12. **Ma** is a question marker (Q) in Mandarin Chinese.

13. Cf. Note 11 of this chapter.

14. In an intonation unit, primary stress can take place on two items of given information only when

they are put in contrast. (see also Halliday 1994; Chafe 1994)

15. A Chinese character in the neutral tone is counted as $\frac{1}{4}$ syllable.

16. In this thesis, on occasion when the distinction between a cinema movie and a television drama is considered insignificant, the word *film* is given expediency of being a neutral term. Most of time though, the generic term *teleplay* is used to refer to the TV series.

17. This refers to the situation in the mid-1994. Such a translation team affiliated to a television station, by definition, consisted of a translation office, a full-time dubbing crew including a dubbing director (at least), dubbing performers and the technical personnel and a production workshop.

18. In most cases, only an abridged version of the continuity script is available to the film translator, which includes the full dialogue list as well as the cast list and production credits.

19. In the case of this study, all the transcription of the dialogues and their translations of the two data films were done by myself.

20. In the analysis of the entire teleplay, the comparison of the intonation units was mainly done by parallel-text cross-viewing, marking and note-taking. The arrangement of IUs in separate lines is only for illustrating samples used in this thesis.

Chapter 5

APPLICATION OF THE FITNIATS MODEL

5.1 The Test Case: *Jackie*

The mini-series *A Woman Named Jackie* (*Jackie*) starring Roma Downey is a biographical portrayal of the first lady Jacqueline B. Kennedy Onassis (1929-1994). Despite some discernible suspicion about its propagandist element from among audiences, who perhaps unconsciously pass judgement on the political correctness of the story, the Emmy Award nominee has won general acclaim for its artistic quality. In my view, it is also a linguistically successful drama in that the dialogue plays its heavy part functionally and appropriately throughout. *Jackie* was introduced to the Chinese TV audience in May 1993 when the dubbed version was made by the dubbing team of Guangdong Television station. Regretfully, the translation (FDt1) typifies a problem-ridden outcome of the traditional sentence-by-sentence literary translation approach which has been widely adopted in China.

An attempted improvement of FDt1, my own translation (FDt2) of the dialogue in *Jackie*¹ is a product of SL-oriented translation observant of the new methodology proposed in this thesis. It is compared with the original text (FDs) and FDt1 to demonstrate the viability of the FITNIAST model and offers supporting evidence of the dubious quality of FDt1 to the identification the mismatches between FDs and FDt1.

The discourse structure of the teleplay is perceived as consisting of six tiers with the Scene being the working unit for the translator's break-up of the task. Figure 19 shows that it is, from top down, divided into:

3 parts → 7 acts each → 150 scenes in all
(Part 1: 47; Part 2: 64; Part 3: 39) →
speech act sequences (which sometimes
coincide with scenes) → turns → intonation
units (the unit of FDT).

The mapping of the basic structure of a film gives the translator a clear and correct orientation, which is a necessary step before setting about the task of the analysis and translation, especially if it is a sizeable one.

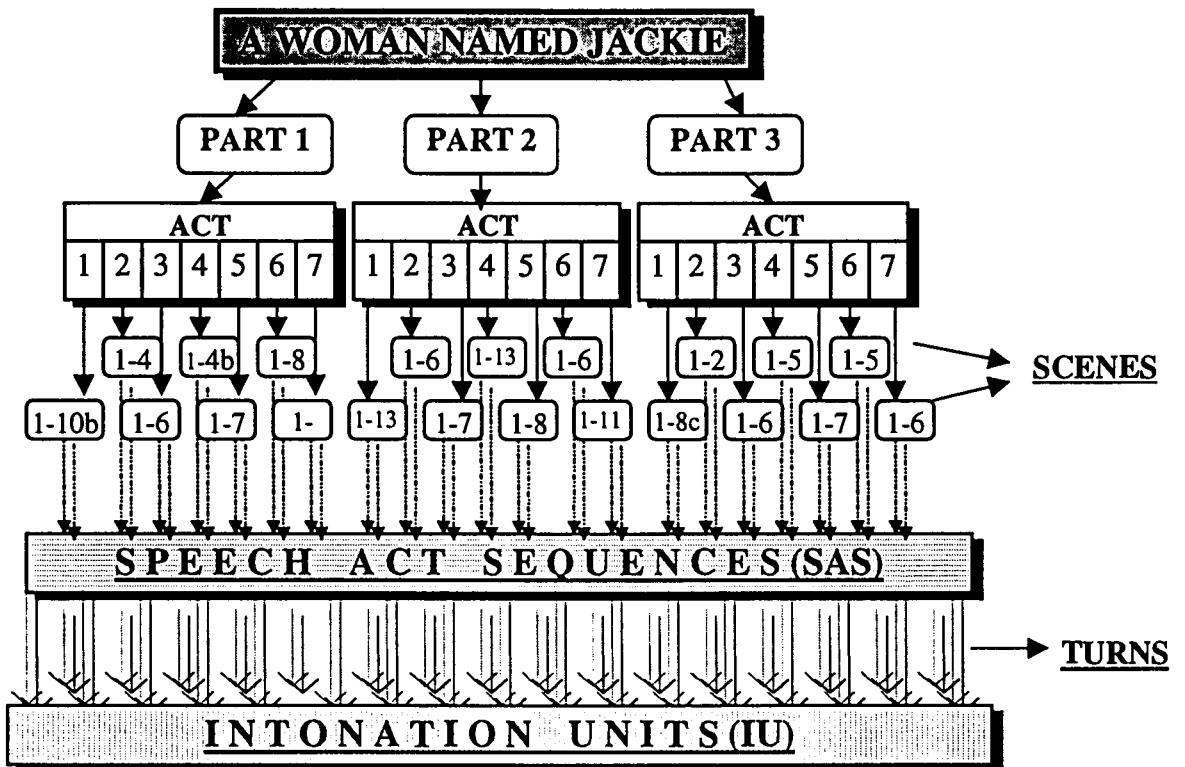

Figure 19

Basic Discourse structure of *Jackie*

By following the above plan throughout in my initial study of the data, I have compared the GDTV translation with the English original and verified my assumption that FDT1 is a strictly sentence-by-sentence translation derived from the conventional film translation approach that views the structure of a film as simply consisting of sentences assigned to different characters contained by the scene. By failing to see the important roles of the SAS and IU in a spoken discourse, it has missed out on perceiving and interpreting the very key constituents of the interactional and informational

constructs which are vital to film dialogue translation.

In this case study, I have randomly selected three samples from my experimentation with the data, each covering the dialogue in a scene which appears in a different part of *Jackie*. Since FDt1 was obviously done according to the continuity script² of the teleplay which was not available to me, I transcribed the dialogue soundtrack from a videotaped copy of the teleplay³ to ensure that the same source text as the dialogue included in the continuity script was used for my translation and analysis.

In the following analysis, these three samples will be treated in their respective sections; with comments, where necessary, after each analysed IU and character's turn, and discussions at the end of each speech act sequence as well as the end of each section. A general discussion and summary of the results from the study of the whole teleplay will be delivered in the final section.

5.2 Sample 1: *Breakup*

The first sample for analysis is excerpted from my transcription of the original dialogue in Scene 4,

Act 1, Part 1 of the teleplay. The dialogue sounds like an intense dispute that reveals the apparent crisis of a marital relationship. Triggered by another 'leak' of the husband's loose living anecdotes, a verbal duel follows between Janet and Bouvier, Jackie's alienated parents. The couple vociferate deep-seated prejudice they hold against each other throughout the irreconcilable wrangle in this scene, which foreshadows their imminent divorce. The process of data analyses of this first sample will be detailed in the following parts of this section.

5.2.1 Analysis of the Source Text

The *mise-en-scène* is perceived as an upper-middle-class family in America of the mid-30s. The speakers are two opinionated people who are being disdainful of one another with respect to what one is proud of possessing, which is held as what the other is lacking, i.e., Bouvier's self-styled 'nobleness' versus Janet's self-assured 'noble-mindedness'. The analysis will start from identifying the central theme and the general tone of this dialogue segment.

The Scene

It can be entitled "Break-up" as the dissension between the couple has brought their marriage to a head. The general tone of the scene as revealed by the exchanges of the verbal and non-verbal message is loveless, cutting, antagonistic and tit-for-tat.

The Speech Act Sequences

Next, dividing the dialogue into speech acts and SASs, and marking each of them sequentially, we put the goals of the interaction at the SAS level in perspective. Here is the initially coded transcription (up to the Turn level) of the dialogue. A number in brackets is given to each preceding speech act; at the end of each SAS, its referring number is interposed between the symbols >>> and //. Any information put in square brackets to show the locale, action or moods of the character, etc. is from my interpretations of the actual show as seen on the videotape. An N-dash " - " indicates where an interruption occurs.

[Jackie Sc.1-1.4]

[The morning after the horse-riding competition at the jumping course, where a local tabloid photographer caught Bouvier and Lorrain Murrey in the act of literally holding hands behind Janet's back as she posed for the winner's picture. At the

breakfast table, Janet is opening her mail. She looks at a newspaper clipping and a note.]

JANET: Interesting item in the *Daily News*: "... It looks like the Bouviers and Miss Murrey are having a grand old time." [pause, then angrily] ... Behind the dumb little wife's back. (1)

BOUVIER: Don't be silly. I'm fond of Lorraine, just as you are - (2)

JANET: You bastard! (3)

BOUVIER: For Heaven's sake, we're just friends! (4) I had no idea we would be in the picture.... Who sent you this? (5)

JANET: A good friend who wanted me to know, [reading the note] "... what everybody else already knows about Jack.". But of course I've known all along.(6) You can't keep your trousers buttoned.(7) >>>SAS#1//

BOUVIER: [maintaining dignity] The difference between you and I, my dear, is that you're so terrified of not fitting in, you've forgotten how to live - (8)

JANET: I know how to live a decent, proper life! (9)

BOUVIER: you can't take a breath without referring to an etiquette book! (10)

JANET: You should try sometimes. (11)

BOUVIER: I don't give a tinker's damn what people say. (12)

JANET: [sarcastic] Of course you don't - because you're a selfish drunk! (13)

>>>SAS#2//

BOUVIER: My drinking was never a problem when the Bouvier name got you into the Social Register. (14)

JANET: That was not why I married you. (15)

BOUVIER: So you never wanted from me. (16)

JANET: [voice trembling] That's not true. I want a husband. A family - (17)

BOUVIER: [scornful] A family! All you want to do is claw your way to the top of society because your father came from nowhere - (18)

JANET: [incensed] At least my father made his own money! (19)

BOUVIER: Mine didn't? (20)

JANET: And he doesn't lie about our family history like your father ... [breaks out] shamelessly making up a story that you're descended from French aristocracy - (21)

BOUVIER: The Bouvier did descend from French aristocracy. (22)

JANET: [loudly] The Bouviers were nothing but a bunch of filthy cow farmers! (23)

BOUVIER: For better or worse, we are what we are. (24)
 JANET: I can't accept that. (25)
 >>>SAS#3//
 BOUVIER: The question then is, how do you choose to live your life? (26)
 JANET: Exactly. (27)
 BOUVIER: Elevated like I do? Or by the book like you do? (28)
 JANET: [calmly] I choose to make a respectable life for my daughters.
 [determined] If necessary, I do by myself. (29)
 >>>SAS#4//

There are 4 Speech Act Sequences in this dialogue, each being profiled in terms of topic, function and adjacency pair (AP) status as follows:

SAS #1: (1) - (7)

Topic: Janet's anger over Bouvier's cheat
Function: Cause of the conflict
Adjacency pair status:
 AP1 [(1)-(2)]: AAP, UAP; AP2 [(3)-(4)]:CAP_A, TAP; AP3 [(5)-(6)]: CAP_A, TAP; AP4 [(7)-(7)]: CAP_A, UAP.

SAS #2: (8) - (13)

Topic: Mutual criticism of each other's way of life
Function: Bouvier's diversion of the confrontation
Adjacency pair status:
 AP5 [(8)-(9)]: AAP, TAP; AP6 [(10)-(11)]: AAP, TAP; AP7 [(12)-(13)]:CAP_A, TAP.

SAS #3: (14) - (25)

Topic: Low opinions of each other's background
Function: Step-up of the conflict
Adjacency pair status:

AP8 [(14)-(15)]: CAP_A, UAP; AP9 [(16)-(17)]: CAP_A, UAP; AP10 [(18)-(19)]: CAP_A, UAP; AP11 [(20)-(21)]: CAP_A, UAP; AP12 [(22)-(23)]: CAP_A, TAP; AP13 [(24)-(25)]: CAP_A, TAP.

SAS #4: (26) - (29)

Topic: Hint of the forthcoming break-up

Function: Outcome of the conflict

Adjacency pair status:

AP14 [(26)-(27)]: CAP_A, TAP; AP15 [(28)-(29)]: CAP_A, TAP.

While the main clues to the interactive patterning are usually uncovered by a stylistic analysis of the dramatic discourse in terms of its adjacency pairs, turn-taking and speech-act functions effected, the interpretation of the AP status from the standpoint of AP type distinction provides an extra dimension in which the power relations between the interlocutors and their attitudes can be monitored. From the above SAS-focused findings, the occurrences of different types of AP in this dialogue is summed up in Table 7.

Total # of Adjacency Pairs =15	AAP	%	CAP A P		%	TAP	%	UAP	%
JANET	1	6.7	2	-	13.3	8	53.3	4	26.7
BOUVIER	2	13.3	10	-	66.7	1	6.7	2	13.3
TOTAL (% of total APs)	3	20	12		80	9	60	6	40

Table 7

Sample 1:
Number and percentage of types of adjacency pairs ascribed to each character

From the above tally, we are informed of the drift of the APs and speaker-hearer power status in this interaction in at least 5 respects:

1. Overall, this dialogue is dominated by the use of CAP_s (80%), showing a volley of unhesitating comebacks to the partner's retorts. This is compatible with the escalating tension of a heated argument in which a speaker tends to take up the previous issue raised by the other party but remains in an aggressive role by initiating a new point.
2. On the other hand, there are more TAPs than UAPs in the whole dialogue (with a ratio of 3:2), five out of 6 of the latter category being the results of interruption and one (the silent response to (7)) being Bouvier's choice to avoid a clash with Janet on his amour. Such repeated presence of TAPs in this context suggests the nonnegotiable situation as the prevailing attitude adopted is straightforward and conclusive.
3. Bouvier holds most of the Speaker role (12 AAPs and CAP_s, or 66.7%, of the total) to " get the upper hand" , a clear indication that he is more in control of the talk.
4. By contrast, the only three initiations of AP by Janet are emotionally driven - her response to the surprising exposure of her husband's affair in (1) as AAP and her two angry curses in (3) and (7) as CAP_s, are

delivered somewhat impulsively (immediately following her last speech act/move). This further reflects her passiveness in the quarrel.

5. However, in almost all her other responses (except for those cut short by Bouvier), Janet uses TAPs to return his affronts, which proves her unequivocal and determined stance.

Such an observation is meaningful in that the translator needs to ascertain how the interactional structuring serves the conversation goals and how the pragmatic principles operating in this dialogue correspond to the verbal information content and extralinguistic features, before an equally cohesive discourse can be reinstated in the TL. In fact, the conversational metastrategy adopted by the speakers is consistent with their sociolinguistic roles in terms of the speaking end, key and form (Hymes 1972), which are created here to effect characterization. A further look at what is entailed in the function each speech act performs in relation to the turn-taking pattern will further clarify this reality in the dramatic world being created.

The Turns

The functions that the 29 speech acts in 27 turns serve in the dialogue as drawn up in Figure 20 provide an array of links to substantiate the topic flow within the interactional frame. The adjacency pairs are conjoined by >; standing-alone speech acts are marked with →. Where there is more than one function performed within the same stretch of utterance (as in Speech Acts (1), (2), (5), (6), etc.), the second speech act function is counted as the main intent. For expediency, they are exclusively treated as two moves dealing a single illocutionary force and brought together in one speech act box (with a hyphen) in the ensuing analysis. According to Halliday's broad classification of speech act function (Halliday 1994:69), the turn-taking structure of the dialogue progresses like this:

Scene: Break-up

Abbreviations — Ack(nowledge.) = Acknowledgement; Ans. = Answer; Ccmd. = Command; Disc. = Disclaimer; Que. = Question; State. = Statement

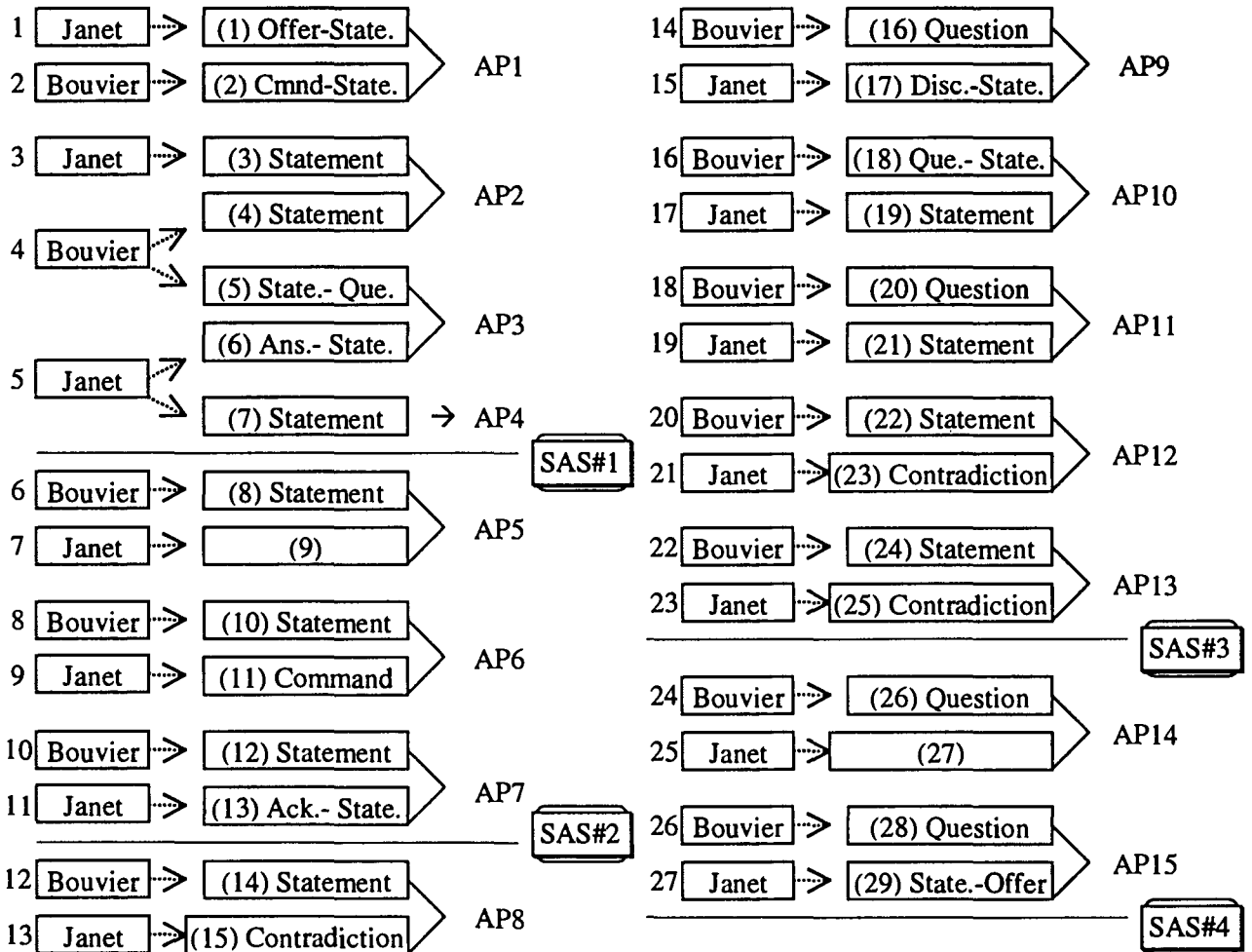

Figure 20
Sample 1: The performance of speech acts in the organization of the turn, AP and SAS

The identification of the speech act functions evidences the turn-taking strategy used in this dialogue and enables the translation to be clearly oriented at the turn level. This progression chart has at least these significant points to offer:

1. According to Halliday (ibid.), contrary to an expected response to an initiating speech act in an AP, a discretionary alternative usually represents some negative or disagreeable reaction, e.g. rejection of an offer, refusal to a command, contradiction to a statement or disclaimer to a question. As can be seen in (9), (15), (17), (23) and (25) in this selection, Janet uses 5 such contradicting speech acts explicitly in reply to Bouvier, who uses none of them. This shows that Janet's attitude in this talk is more straightforward and her position is more on the defensive.

2. However, the main response strategy for both of them is using an initiating speech act, be it a statement, a question or a command; or a CAP_A, where a CAP_p is normally used, e.g., in (4), (8), (22) and (29). Altogether, there are 11 instances of such deviant use of an initiation instead of a direct response that would have been elicited by the previous speech act. The repeated occurrence of counter-attack by sticking to one's own point while avoiding or ignoring the other's challenge indicates the speakers' mutual contempt and their obstinacy in their critical relationship. On the other hand, it also accounts for Bouvier's evasive tactic about his infidelity as well as the fact that the conflict is still kept under restraint in spite of the sustained exchanges of riposte.

3. With respect to those 8 places in this selection where more than one move occurs in an utterance intended to perform a speech act, they are all instances of attempted indirect speech act at the onset but yielding to a direct speech act to end the turn, meaning that the grim nature of the opposition favours little verbal manoeuvring notwithstanding the speakers' apparent preference for a genteel manner to asperity.

4. The relatively low occurrence of turns consisting of more than one speech act in each (spotted only in Turns 4 and 5) reflects the changing tempo of the argument.

The analysis of the forms and functions of its constituent speech acts further clarifies the relations between the macro and micro structures of film dialogue and elucidates the distinction between the key constructs at the turn level and the sentence, which is the only focus of the traditional translation approach in terms of the unit for analysis and of translation. Our view of the dialogue is yet to extend to the smaller segment to get hold of the flow of information.

The Intonation Units

With the provision of a lucid context within which increments of information are built up to form the identified speech acts, we are ready to break down the dialogue into units of intonation and to mark out the new information they contain.

The 55 IUs as separated below reveal the micro structure of the dialogue with the effect of showing the information flow and focus. Each IU contains one or more than one idea unit; the accented words are either new (boldfaced) or accessible information in the consciousness of the hearer. Some are in the form of single words or single words as separate lexical items lined up for emphasis or in contrast; others are lexical items combined into one concept. The latter is usually found in cases of a verbal structure (auxiliary verb plus the verb), an idiomatic collocation and an NP. In this dialogue, the new information representations in the IUs (4, 13, 14, 16, 19, 22, 23, 34, and 49) come in more than one word and they should be taken as a whole. The symbol " = " indicates the lengthening of the preceding syllable.

- JANET: (1) ... **Interesting** item .. in the Daily **News**
(2) ... It looks like that **Bouviere** and Miss **Murrey**

(3) .. are having a **grand** old time.

(4) ... **Behind** the dumb little wife's **back** .

BOUVIER: (5) ... Don't be **silly** =.

(6) ... **I'm** fond of Lorraine! just as **you** are –

JANET: (7) .. You **bastard!**

BOUVIER: (8) ... For **Heaven's** sake .. we're just **friends** =!

(9) ... I had **no** idea we would be in the **picture**.–

(10) ..**Who** sent you this?

JANET: (11) ... A good **friend** who wanted me to **know**,

(12) ... what everybody **else** **already** knows about Jack..

(13) ... **But** of **course** I've known **all** **along**.

(14) ... You **can't** **keep** your trousers **buttoned**.
>>>SAS#1//

BOUVIER: (15) ... The **difference** between **you** and **I** .. my dear,

(16) ..is that you're so **terrified** of not **fitting** **in**,

(17) .. you've **forgotten** how to **live** –

JANET: (18) ... I know how to live a **decent**, **proper** life!

BOUVIER: (19) ... you **can't** **take** a **breath**

(20) .. **without** referring to an **etiquette** book!

JANET: (21) ... **You** should try sometimes.

BOUVIER: (22) ... I don't **give** a **tinker's** **damn** | what people **say**.

JANET: (23) ... **Of** **course** you **don't** –

(24) .. because you're a **selfish** **drunk!** >>>SAS#2//

BOUVIER: (25) ... **My** drinking was **never** a problem

(26) .. when the **Bouvier** name got you into the Social **Register**.

JANET: (27) ... That was **not** **why** I married you.

BOUVIER: (28) ... So you **never** **wanted** from me.

JANET: (29) ... That's **not** **true**.

(30) ... I want a **husband**.

(31) ... A **family** –

BOUVIER: (32) ..A **family!**

(33) ... **All** you want to do

(34) .. is **claw** your **way** | to the **top** of **society**

(35) .. because your **father** came from **nowhere** –

JANET: (36) .. At least ^my father made his ^^own money!

BOUVIER: (37) ... ^^Mine didn't?

JANET: (38) ... And he doesn't ^^lie about our family history
(39) .. like ^^your father–
(40) ... ^^shamelessly ^making up a story
(41) .. that you're descended from ^French ^^aristocracy –

BOUVIER: (42) ... The Bouvier ^^did ^descend from French aristocracy.

JANET: (43) ... The Bouviers were ^^nothing =
(44) .. but a bunch of ^filthy ^^cow ^^farmers!

BOUVIER: (45) ... For ^^better or ^^worse,
(46) .. we ^are what we ^^are.

JANET: (47) ... I ^^can't accept ^that. >>>SAS#3//

BOUVIER: (48) ... The ^^question then ^is,
(49) ..how do you choose to ^live your ^^life?

JANET: (50) ... ^^Exactly.

BOUVIER: (51) ... ^^Elevated like ^I do?
(52) ... Or by the ^book like ^^you do?

JANET: (53) ... I choose to make a ^^respectable life | for my ^^daughters.
(54) ... If ^^necessary,
(55) ... I ^do by ^^myself. >>>SAS#4//

Summary

The eventual narrowing down of the analysis to IUs forms the basis on which specific criteria can be readily comprehended for the translation to meet. To provide a complete view of the dialogue with its structural and contextual bearings at a glance, Table 8 incorporates the results of the analysis from each step into an elaborate IU list, where bracketed turns show the second speech act that is delivered by the same speaker; and the speech acts

numbered (-a) or (-b) indicates one of the two moves within the same speech act.

Jackie Sc.1-1.4

Scene: Break-up

Tone: shaming, cutting, antagonistic

TURN	SPEECH ACT FUNCTION	I U	CODED TRANSCRIPT OF THE DIALOGUE	Adjac. Pair STATUS	SAS TOPIC
1. JANET	(1a) Offer	1	... ^Interesting item .. in the Daily ^News	AP1:	SAS#1 Topic: Janet's anger over Bouvier's cheat
		2	... It looks like that ^Bouviere and Miss ^Murrey	AAP/ UAP	
		3	..are having a ^grand ^old time.		
	(1b) Statement	4	... ^Behind the dumb little wife's ^back .		
2. BOUVIER	(2a) Command	5	... Don't be ^silly =.		
	(2b) Statement	6	... ^I'm ^fond of Lorraine! just as ^you are -		
3. JANET	(3) Statement	7	.. You ^bastard!	AP2:	
4. BOUVIER	(4) Statement	8	... For ^Heaven's sake .. we're just ^friends =!	CAP _A / TAP	Function:
(BOUVIER)	(5a) Statement	9	... I had ^no idea we would be in the ^picture.-	AP3:	Cause of the Conflict
	(5b) Question	10	..^Who sent you this?	CAP _A / TAP	
5. JANET	(6a) Answer	11	... A good ^friend who wanted me to ^know,		
		12	... what everybody ^else ^already knows about Jack..		
	(6b) Statement	13	... But of ^course I've known all ^^along.		
(JANET)	(7) Statement →	14	... You ^can't keep your trousers ^^buttoned.	AP4: CAP _A / UAP	
6. BOUVIER	(8) Statement	15	... The ^^difference between ^you and ^I .. my dear,	AP5:	SAS#2 Topic: Mutual criticism of each other's way of life
		16	..is that you're so ^terrified of not fitting ^^in,	AAP/ TAP	
		17	.. you've ^forgotten how to ^^live -		
7. JANET	(9) Contradiction	18	... I know how to live a ^decent, ^^proper life!		
8. BOUVIER	(10) Statement	19	... you ^can't take a ^breath	AP6:	each other's way of life
		20	.. ^without referring to an ^^etiquette book!	AAP/ TAP	
9. JANET	(11) Command	21	... ^^You should try sometimes.		
10. BOUVIER	(12) Statement	22	... I don't give a ^tinker's ^^damn what people ^^say.	AP7: CAP _A TAP	Function: B's Diver- sion of the confrontation
11. JANET	(13a) Acknowledg..	23	... Of ^^course you ^don't -		
	(13b) Statement	24	.. because you're a ^selfish ^^drunk!		
12. BOUVIER	(14) Statement	25	... ^My drinking was ^^never a problem	AP8:	SAS#3 Topic: Low opinions
		26	.. when the ^Bouvier name got ^you into the Social ^Register.	CAP _A / TAP	

13. JANET	(15) Contradiction	27	... That was ^not ^^why I married you.		of each other's background
14. BOUVIER	(16) Question	28	... So you ^^never ^wanted from me.	AP9:	
15. JANET	(17a) Disclaimer	29	... That's ^not ^^true.	CAP _A / UAP	
	(17b) Statement	30	... I ^^want a husband.		<i>Function:</i> Step-up of the conflict
		31	... A ^^family –		
16. BOUVIER	(18a) Question	32	..A ^^family!	AP10:	
	(18b) Statement	33	... ^^All you want to do	CAP _A / TAP	
		34	.. is ^claw your ^^way to the ^^top of ^society		
		35	.. because your ^father came from ^^nowhere –		
17. JANET	(19) Statement	36	.. At least ^my father made his ^^own money!		
18. BOUVIER	(20) Question	37	... ^^Mine didn't?	AP11:	
19. JANET	(21) Statement	38	... And he doesn't ^^lie about our family history	CAP _A / UAP	
		39	.. like ^^your father–		
		40	... ^^shamelessly ^making up a story		
		41	.. that you're descended from ^French^^aristocracy –		
20. BOUVIER	(22) Statement	42	... The Bouvier ^^did ^descend from French aristocracy.	AP12: CAP _A / TAP	
21. JANET	(23) Contradiction	43	... The Bouviers were ^^no=thing		
		44	.. but a bunch of ^filthy ^^cow ^^farmers!		
22. BOUVIER	(24) Statement	45	... For ^^better or ^^worse,	AP13:	
		46	.. we ^are what we ^^are.	CAP _A / TAP	
23. JANET	(25) Contradiction	47	... I ^^can't accept ^that.		
24. BOUVIER	(26) Question	48	... The ^^question then ^is,	AP14:	SAS#4 <i>Topic:</i>
		49	..how do you choose to ^live your ^^life?	CAP _A / TAP	
25. JANET	(27) Acknowledg.	50	... ^^Exactly.		Hint of the forthcoming break-up
26. BOUVIER	(28) Question	51	... ^^Elevated like ^i do?	AP15:	
		52	... Or by the ^book like ^^you do?	CAP _A / TAP	
27. JANET	(29a) Statement	53	... I choose to make a ^^respectable life for my ^^daughters.		<i>Function:</i> Outcome of the conflict
	(29b) Offer	54	... If ^^necessary,		
		55	.. I ^do by ^^myself.		

Table 8

Structural breakdown of the Scene *Break-up* and the contextual relations between its components from both informational and interactional perspectives

This summary sheet serves as a quick overview of the analysis findings and is to be used for the other samples under study in this chapters to represent the bulk of the analysis outcome. Even

though it is not necessarily used as the standard format for a dialogue script analysed, the principles of segmentation and coding and the parameters involved must be observed throughout the analysis process.

This analysis has presented the relevant information mainly in a macro perspective; with this discernment, micro-analysis of the dialogue as to what linguistic, stylistic, socio-cultural and pragmatic particulars it features must be represented in the translation will be considered in the course of the comparison and evaluation.

5.2.2 Comparison and Evaluation

In the above analysis, we have interpreted the FDs sample in terms of its informational and interactional underpinnings which account for its FIT functions or FITness features. In the parallel analysis that follows, segments of FDt1 are placed to the left and FDt2 to the right of a line separating the two translations, which are superposed by the original as the embodiment of the standard against which they are assessed.

Both versions of FDt are presented in the Romanized pinyin script in italic typeface. Each pinyin

representation of a character or a character group (as the minimal meaningful unit in an idiomatic phrase) has a literal English translation in subscript. The sample is examined IU by IU throughout the analysis and rounded up in four divisions of speech act sequence (**SAS**), under which boundaries are also marked out anterior to each adjacency pair (**AP**) and speech act (**SA**). These three boundary codes consist of the preceding abbreviations numbered in sequence and followed by a symbol of arrowhead " > " (triple, double or single) respectively. To demonstrate the whole process of our analysis, full details are offered below for Sample 1.

SAS#1>>>

AP1>>

1. JANET

SA(1a)>

(1)...^^Interesting item .. in the Daily ^News

... Zai Mei Ri Xin Wen li..
 PreP daily news LOC
 you tiao ^hen you qu de xin wen ...
 have MSR very interesting news

... ^You qu de xiao xi .. Mei Ri`
 interesting news daily
 ^Xin Wen` shang
 news LOC

Although putting a prepositional phrase (PP) at the beginning of a sentence is in keeping with the norm of grammatical Chinese, it is not uncommon to invert the order of the main clause and the PP (expressed as an afterthought) in colloquial usage.

Only in this respect, the word order conforms to that of the corresponding structure in English. **IU(1)** is treated poorly in FDt1 in that it not only loses the original rhythm and information focus but also stretches FDs a bit too far to fit in the designated time slot naturally. By retaining the original syntactic and prosodic features, FDt2 is able to discard *tiao´*, *henˇ* as well as the preposition *zai`* and the verb *youˇ* (which are necessary for more formal style) without sounding less idiomatically Chinese.

(2) ... It looks like that [^]Bouvi^{er} and Miss [^]Murrey

.. *Kan`lai´`[^]Bu`wei´erˇ`he´[^]Mo`liˇ*
 look like Bouvier and Murrey

Xiao`jieˇ
 miss

... *Kan`lai´`[^]Bu`wei´erˇ`he´[^]Mo`liˇ*
 look like Bouvier and Murrey

Xiao`jieˇ
 miss

(3) ..are having a [^]grand [^]old time.

..[^]*ri`zi`guo`de`henˇ[^]yu`kuai`.*
 life spend ASP very happy

... *qing´[^]shen`|[^]yi`chang`=´.*
 affection deep friendship long

Both FDt's use the substitution strategy to avoid literal translation of the phrase in **IU(3)**, but with different effects. The translation in FDt1, while not short of the sarcastic tone, sounds too explicit about the affair between Bouvier and Miss Murrey; hence semantically it does not fit. Using a set phrase (a four-character idiom), FDt2 conveys

the original meaning appropriately for the reason that the phrase is most often used to suggest and describe the on-going aspect of an intimate relationship, such as in commenting on a live scene or a picture. Being of the Type 4 match, it keeps the mid-focus of new information, while the longer duration of the stressed syllables and the lengthening of the final sound fill up the timing gap left by the reduced number of syllables as compared with the FDs.

SA(1b)>

(4) ... [^]Behind the dumb little wife's ^{^^}back .

.. Shi ^{^^}bei zhe nei ge ^{^^}ben dan`
 be behind that MSR stupid
[^]qi zi gan de.
 wife do ASP

... [^]zai ta ben dan` tai tai de
^{^^}bei hou`
 PreP his stupid wife MOD back

Putting the flexibility of spoken language grammar aside, FDT1 uses a clause in the emphatic "**shi`... de**" construction to render this PP, only to sound wordy and upset the original NI focus. Actually, "**zai`... (sb. de) bei hou`**" matches the English "**behind ... (sb's) back**" formally and functionally.

2. BOUVIER

SA(2a)>

(5)... Don't be ^{^^}silly =

... Ni ^{^^}bie fan sha` le
 you don't be silly ASP

... Bie fa` ^{^^}sha`
 don't be silly

Another instance found in FDt1 of being unnecessarily wordy to mean more spoken-like at the expense of the SL's form and function. FDt2 has overcome this common FDT problem of using too much discretion in rendering colloquial expressions to the effect of being further away from spoken style.

SA(2b)>

(6) ... ^I'm ^fond of Lorraine| just as ^^you are -

<p>..wo <u>xi huan</u> ^<u>he jiu</u> ,jiu xiang `^^ni ~ I like drinking just as <u>you</u> <u>xi huan</u> ~ - like</p>	<p>... ^Wo <u>xi huan</u> <u>Ruo lin</u> <u>bu jiu</u> `xiang` I like Lorraine just as ^^ni `ye` ~ - you also</p>
--	--

Obviously, FDt1 mistranslates the original meaning of Lorraine, the first name of Miss Murrey, for a wine brand; hence he jiu (drinking) is initiated as new information out of context.

AP2>>

3. JANET

SA(3)>

(7) .. You ^^bastard!

<p>.. Ni ~ zhei `ge` ^<u>chu sheng</u>! you this MSR beast</p>	<p>... Ni ~ ^^<u>hun zhang</u> `! you bastard</p>
---	--

FDt1 is being too strong in connotation and in tone by using the word chu sheng and in so doing has to interject zhei ge between ni and the curse word. The word hun zhang chosen by FDt2 has the

association of messing around sexually in the northern Chinese culture apart from being a less piercing cuss, hence a suitable one for the swearing in this context.

4. BOUVIER

SA(4)>

(8) ... For ^Heaven's sake .. we're just ^^friends =!

Kan`zai`^^Shang`^di`de`fen`shang,Zhen`
In the name of God Janet

ni`ie..wo`he`ia`bu`guo`shi`^^peng`you!
I and she only be friends

... Shang`^tian`bao`zheng`..wo`men`zhi`
Swear to Heaven we just

shi`^^peng`=you!
be friends

FDt1 has too many syllables for the original IU length due to two mishandled renditions. The expletive, though the common translation of the western-style swearing, sounds too dramatic and cliched for the context. The other problem lies in the much expanded subject for **we** (wo`he`ta`.), the disastrous consequence of the mistranslation in SA (2b). On the other hand, FDt2 follows the original closely, an ideal case of Type 1 match.

AP3>>

SA(5a)>

(9) ... I had ^no idea we would be in the ^^picture.-

... Wo`mei`xiang`dao`hui`zai`^^zhao`
I not think ASP would PreP photo

pian`shang`chu`xian`.
LOC appear

... Mei`^xiang`dao`wo`men`hui`shang`
Not think ASP we would be in

^^zhao`pian`r`
photo

One of the recurring problems in FDt1 is the unnecessary retention of the deictic subject for the Chinese sentence, which reduces its naturalness and leaves less room for the overall formal correspondence between the two languages, since zero anaphora as the more likely Chinese usage in these situations should be observed.

SA(5b)>

(10) ..^^Who sent you this?

.. ^^Shei 'gei 'ni ~ de?
who give you ASP

| .. ^^Shei 'gei 'ni ~ de?
| who give you ASP

5. JANET

SA(6a)>

(11) ... A good ^^friend who wanted me to ^know,

..Shi 'yi ~ wei ` xiang rang wo ~ ^^zhi ~dao`
Be one MSR want let me know
zhe jian `shi ` de hao ~ ^^peng you.
this MSR affair MOD good friend

| ... Yi ` ge ` hao ~ ^^peng you xiang`
| One MSR good friend want
| rang `wo ~ ^^zhi ~dao`
| let me know

By treating the NP modifier as the predicate, FDt2 has avoided the inversion problem in FDt1 that the relative clause is left-dislocated in keeping with the normal Chinese word order at the expense of the correct positioning of the information focus **peng you** (friend). The in-situ prosodic prominence in FDt2 functions as the recompensing device for this syntactic discrepancy in terms of a major departure from the original grammatical rank and paves the way for transiting functionally to the next IU.

(12) .. what everybody ^{else} ^{already} knows about Jack..

<p>..zhe `shi` ^<u>zhong suo zhou zhi`</u> de, this be well-known MOD</p> <p><u>guan`yu`</u> ^<u>Bu wei er`</u> de shi` about Bouvier MOD affair</p>	<p>.. <u>Da jia`</u> ^<u>dou zhi`dao`</u> de <u>you`guan`</u> everybody all know MOD about</p> <p><u>Jie ke`</u> de shir` Jack MOD affair</p>
--	---

As the consequence of rigidly sticking to the typical Chinese word order in the preceding FDt1, the meaning of the embedded object clause of FDs here is initiated in the form of an incoherent-sounding sentence on the left side above. The translation on the right, by contrast, remains the natural object of the verb **zhi`dao`** (to know) in FDt2 for IU(11).

SA(6b)>

(13) ... But of ^{course} I've known all ^{along}.

<p>..<u>Dang`ran`</u> ,wo` ye` ^<u>yi`zhi`</u> ^<u>zhi`dao`</u> of course I also all along know</p> <p><u>zhei`jian`shi`</u> this MRS affair</p>	<p>... ^<u>Dang`ran`</u> wo` xin` li` yi`zhi` of course my mind LOC all along</p> <p><u>dou`</u> ^<u>ming`bai`</u> all clear</p>
--	--

FDt2 here has achieved the Type 4 match effect by using the idiomatic phrase **xi`li ming`bai** (clear in one's mind) instead of the weaker Chinese word **zhi`dao`** to reflect more appropriately the degree of one's knowledge of something secretive throughout its course, which is exactly what the original intends to convey. The end-focus compensates for the left-dislocation of **yi`zhi`** (all along), an

adverbial phrase which in Chinese rarely appears at the end of an utterance.

AP4>>

SA(7)>

(14) ... You ^can't keep your trousers ^^buttoned.

..Ni <u>dexing</u> <u>wei</u> ^^ jiu <u>shi</u> <u>bu</u> <u>jian</u> <u>dian</u>Ni ~^jiu <u>bu</u> <u>neng</u> <u>ba</u> <u>ku</u> <u>lian</u> ^^la <u>jin</u> .
your conduct just be not restrained		you just can't PreP zipper pull tight

FDt1 chooses to interpret the slangy expression in a more Chinese and much more formal manner while failing to strike home the original force of contempt and indignation produced by the pungent idiom. Contrastingly, FDt2 effectively transfers it into an SL-oriented phrase, which is vividly exotic but perfectly comprehensible to the TL audience. In fact, this example of desirable foreignization has achieved the equivalent effect to the original in almost all dimensions of FITness.

From the analysis above, it can be seen that even though it has conveyed the general propositional meaning understandably, FDt1 of this speech act sequence is a problematic translation on a number of accounts. First, in rearranging the word order according to the Chinese syntactic rules, it has made two instances of major inversion in the first and last turns only to bring about a catastrophic

effect in dubbing. Second, it has committed an unforgivable mistranslation in **SA(2b)** which puts the cohesiveness of the whole sequence in jeopardy. Third, it has lost some genre features of spoken language present in the original, such as terseness and idiomaticity. None of these problems is found in FDt2 of the same dialogue segment, which implies that they could have been avoided in FDt1 if the approach appropriate for dubbing (E-C) had been adopted.

Summary of SAS#1

In this summary of **SAS#1** and the ensuing ones, we concentrate on two major aspects of FDt1 which are particularly relevant to translation for dubbing, viz., syllables used per turn and in the whole SAS, in comparison with FDs and FDt2; and instances of failure to designate correctly new information in each IU of FDt1 as benchmarked against the FDs' information structure. As defined for the previous examples, a Chinese character in the neutral tone is counted as half a syllable in duration for all the statistics in this chapter.

TURN NUMBER OF		1	2	3	4	5	SAS#1 TOTAL
		FDs	<i>Syll.</i>	35	14	3	
FDt1	<i>Diff.</i>	+4	+0.5	+2	+8	+8.5	+23 (20%)
	<i>Syll.</i>	39	14.5	5	32	46.5	137
FDt2	<i>Diff.</i>	-4	-1	0	-2.5	+0.5	-7 (6.1%)
	<i>Syll.</i>	31	13	3	21.5	38.5	107

<p>Abbreviations</p> <p><i>Syll.</i>: number of syllables; <i>Diff.</i>: Difference; +: more; -: less</p>
--

Table 9

Sample 1 - SAS#1:
Number of syllables in each turn and the difference between FDs and FDt

The figures of syllable count in Table 9 measure the total number of syllables constituting each turn and the whole SAS of FDs and FDt. They are only approximations in view of the actual time for articulation designated to each syllable, because the duration of a syllable varies between English and Chinese (stress-timed vs. syllable-timed) and from syllable to syllable in the same language, e.g., the length of a stressed syllable is different from that of an unstressed one. Nevertheless, the difference in number of syllables in this sequence between FDt1 and FDs is too significant to be taken as coincidental. The densely-worded spoken segments reflect an unnaturally faster tempo at which FDt has to be

vocalized as compared with the original delivery speed in the same time slots. In contrast, FDT2 maintains its fidelity to FDs in keeping with its rhythm and pace at which a close syllable count is achieved.

The other notable quantified outcome of the analysis is concerned with the rate of corruption of the information structure at the level of the IU in FDT1.

TURN		1				2		3	4			5				SAS Σ=
IU		1	2	3	4	5	6	7	8	9	10	11	12	13	14	14
NI	<i>D</i>			X					X	X		X		X		5
	<i>M</i>				X											1
	<i>DM</i>	X				X	X								X	4
TOTAL		3				2		-	2			3				10
%		75%				100%		0	67%			75%				71%

Abbreviations
D: dislocated; *M*: misplaced; *DM*: both *D* and *M*; Σ=: total; %: percentage of wrong information focus in a turn / SAS as tallied against FDs' total number of NIs

Table 10

**Sample 1 - SAS#1:
 Instances of loss of NI synchronicity with the original timing obtained in FDT1**

As shown in Table 10, of the 14 IUs that constitute the speech act sequence, ten of them have either failed to keep the new information to the original timing for each of the IUs or placed the NI on the wrong lexical item(s), or have both dislocated⁵ and misplaced the information focus. Although these

figures can only be understood in relative terms, the SAS percentage of the problem occurrence does reveal a high-frequency loss of this crucial function of film dialogue throughout the questionable translation.

SAS#2>>>

AP5>>

6. BOUVIER

SA(8)>

(15) ... The ^{^^}difference between [^]you and [^]I .. my dear,

... [^]Ni [^]he [^]wo zhi jian de [^]qu bei ,
 you and I between MOD difference

	... <u>Wo men</u> ^{^^} <u>bu tong de</u>	<u>di fang</u>
	.. <u>qin ai</u> de,	
	our different point	my dear

In most cases, to translate the English prepositional phrase into Chinese as such, one has to reverse its original position in relation to the word(s) it modifies after the translation. As pointed out earlier, this poses a particular problem in FDT between the two languages where the original word order should be maximally preserved in the TL. In the above IU, FDT2 has achieved the Type 3 match effect in rendering the English PP functionally without putting the NI focus out of place. By means of choosing a less emphatic, but more colloquial, phrase of the same meaning as conveyed through the one opted by FDT1, FDT2 has bypassed the translation dilemma and, with fewer characters called forth to represent the PP,

allowed enough room for the culturally-tinted translation, *qin'ai de* (from the vocative **my dear**), which is unwarrantably left out in FDt1.

(16) ..is that you're so terrified of not fitting in,

..jiu zai yu ni ^{zong shi} hai pa
just lie in you always fear
wo men bu pi pei
we not match

..jiu zai ni zong zhen me hai pa
just PreP you always so afraid
shen huo bu he gui fan
living not conform to rules

FDt1 not only dislocates the information focus but also misinterprets the meaning of **fitting in** entailed in this context.

(17) .. you've forgotten how to live –

..ni yi jing wang le ru he
you already forget ASP how
guo ri zi le
live a life ASP

... ni wang le zen me qu
you forget ASP how to
^{sheng huo}
live

The phrase **how to live** is imprecisely rendered into *ru he* (formal) *guo ri zi* (informal), an odd combination for spoken Chinese.

7. JANET

SA(9)>

(18) ... I know how to live a decent, proper life!

..Wo zhi dao ru he qu guo zheng pai
I know how to spend righteous
de ri zi
MOD days

... Wo zhi dao zen me qu ti mian
I know how to decently
^{zheng pai} de sheng huo
righteously MOD live

Both translations insert the modifiers into the same phrase previously used to recapture the original structuring of the repartee. However, instead of nominalizing the verb for **live** (*sheng`huo`*) and calling in another verb to form a collocation to resemble the "verb + complement" construction **how to live a life**, FDt2 chooses to be more idiomatically Chinese by maintaining the phrase *qu`... sheng`huo`*. Thus it sounds more pointed and dynamic than FDt1 and more in keeping with FDs in spirit where **live** has stayed in its verbal role across the adjacency pair. Another problem found in FDt2, which is unforgivable, is the missing of the meaning carried in word **decent** in FDs.

AP6>>

8. BOUVIER

SA(10)>

(19) ... you ^can't take a ^^breath

<p>..Ni `yao `shi `bu `can `kao `you `guan `^^li `yi `</p> <p>you if not refer about protocol</p> <p>de shu` MOD book</p>	<p>... Ni `^chuan `bu `liao `^^da `qi `</p> <p>you can't take big breath</p>
---	--

Again, this is another challenge of the dilemma to the translator in dealing with an English PP (in this case the Chinese translation needs to convert it into an "if-clause") as to whether to invert

the word order of the translation in the sentence to sound "more Chinese" at the expense of losing the original information focus altogether, or to stick to the FITness principle by availing himself of the grammatical flexibility of spoken Chinese by treating the PP as an increment of idea on the independent clause to approximate the original syntax. FDt2 in choosing to foreignize the translation creatively solves the likely problem of sounding intolerably exotic with such word-order formation that has traditionally been rejected as a typically "westernized sentence"; quite the contrary, it works naturally on the grammar of speech without violating the idiomaticity of translation, as can be seen next.

(20) .. ^without referring to an ^^etiquette book!

..lian kou ~ ^^ qi ye bu gan chuan ~
 even MSR breath ←⁶ not dare take

<p><u>yao</u> <u>shi</u> <u>bu</u> <u>shou</u> <u>zhe</u> ^^ <u>shu</u> <u>ben</u> ~ If not stick to books and</p>	<p><u>jiao</u> <u>tiao</u> ! rules</p>
---	---

The figurative use of **an etiquette book** is appropriately equated with the four-character idiom **shu ben jiao tiao** in FDt2; whereas FDt1's literal translation of it in the previous IU is highly misleading (the similar problem occurs in IU 52).

9. JANET

SA(11)>

(21) ... ^^You ^should try sometimes.

.. ^^Ni ^ye ying gai kan kan.
you too should have a look

... ^^Ni ^dao shi yao zhe yang.
you 'd better need do such

As a consequence of the word-for-word translation of the above metonymy into Chinese which can only be understood literally, FDt1 dwells on the concrete meaning of the verb in association with the previous signification, hence **kan kan** (have a look) is used, a further departure from the original meaning.

AP7>>

10. BOUVIER

SA(12)>

(22) ... I don't give a ^^tinker's damn | what people ^^say.

..Wo cai bu jie yi bie ren zen me
I just not mind others how

...Wo cai bu zai hu bie ren ta ma de
I just not care others CURSE

^kan zen me shuo ne!
think how say M'

zen me shou .
how say

Translating coarse language in film dialogue into TL equivalent is called for as part of a character's sociolinguistic profile. FDt1 is obviously too weak a version to stand for the brazen speech of Bouvier, whose overbearing pride is tellingly revealed by the slang and insolent sharpness of this reply. FDt2 on the other hand reflects these features adequately.

11. JANET

SA(13a)>

(23) ... Of ^{^^}course you [^]don't -

..Ni ^{^^} <u>dang ran</u> bu hui [^] jie yi Ni ^{^^} <u>dang ran</u> bu [^] zai hu -
you of course not will mind		you of course not care

Carried over from the last IU, *jie yi* repeats here in FDT1 only to betray further the improper choice of the words which sound too bookish for the speech situation.

SA(13b)>

(24) .. because you're a [^]selfish ^{^^}drunk!

.. <u>yin wei</u> ni shi ge [^] zi si de		... <u>yin wei</u> ni shi ge [^] zi si de
because you be MSR selfish		because you be MSR selfish
^{^^} <u>jiu gui</u> ?		^{^^} <u>jiu gui</u> ?
drunkard		drunkard

Summary of SAS#2

In this speech act sequence, FDT1 has inverted the word order twice in rendering the two PPs in the original dialogue (IUs 15 and 19-20), so that the Chinese translations read grammatically more naturally in the sentence perspective, but have thus sacrificed their FITNESS with respect to the audio-visual co-ordination in the course of the information delivery. Apart from this NI-misrepresentation problem that is uncalled-for in

dubbing, FDt1 has some less damaging translation problems in four instances (IUs 16, 18, 21 and 22), which will be addressed for quantitative significance in the summary of the entire scene in 5.2.3. In the summary table below, it is noted that FDt1 has exceeded FDs by using 12% more of its total number of syllables. This disparity is just slightly lower compared with the 14% extra syllables used in the previous SAS.

TURN NUMBER OF		6	7	8	9	10	11	SAS#2 TOTAL
FDs	<i>Syll.</i>	30	11	16	5	11	11	84
FDt1	<i>Diff.</i>	0	0	+2.5	+0.5	+1.5	+5.5	+10 (12%)
	<i>Syll.</i>	30	11	18.5	5.5	12.5	16.5	94
FDt2	<i>Diff.</i>	-0.5	+1	-1	+0.5	+1	+4	+5 (6.0%)
	<i>Syll.</i>	29.5	12	15	5.5	12	15	89

Table 11

**Sample 1 - SAS#2:
Number of syllables in each turn and the difference between FDs and FDt**

Also compared with SAS#1, it seems the violation to the FITness principle concerning the translation of information structure in this SAS is less frequent. The next table shows that the information focus has been upset and/or misrepresented in four instances, or in 40% of the IUs of FDt1.

TURN	6			7	8		9	10	11		SAS Σ=
IU	15	16	17	18	19	20	21	22	23	24	10
NI	D	X									1
	M										0
	DM		X		X	X					3
TOTAL	2			-	2		-	-	-		4
%	67%			0	100%		0	0	0		40%

Table 12

**Sample 1 - SAS#2:
Instances of loss of NI synchrony with the original timing obtained in FDt1**

However, three out of these four instances are the total original NI loss (*DM*), which is very similar in severity to the next two SASs (all of them have approximately three-quarters out of the total wrong information structure problems belonging to this type). This phenomenon is partly accountable to FDt1's perceivable disorienting artificiality.

SAS#3>>>

AP8>>

12. BOUVIER

SA(14)>

(25) ... My ^drinking was ^^never a problem

<p>..Wo <u>men</u>^ <u>jie</u> <u>hun</u> ~ni <u>jia</u> ~shang ` ^^<u>Bu</u> `</p> <p style="padding-left: 2em;">we marry you add ASP Bou-</p>	<p>... Wo ~^<u>he</u> <u>jiu</u> ~^^<u>mei</u> <u>you</u> ~guo <u>wen</u> <u>ti</u> `</p> <p style="padding-left: 2em;">my drinking have no ASP problem</p>
<p><u>wei</u> <u>er</u> ~ zhei `ge <u>xing</u> <u>shi</u> `de <u>shi</u> <u>hou</u> `</p> <p style="padding-left: 2em;">vier this MSR surname MOD time</p>	

The translation approach adopted for FDt1 is powerless in keeping the postposition of an adverbial clause unchanged in a sentence, therefore

inversion is resorted to. This devastating shift of the information foci compounded by the inaccurate rendition in the next IU finds these two connected segments of FDt1 a disastrous example of the translation for dubbing.

(26) .. when the **^^Bouvier** name got you into the Social **^Register**.

.. ni ^{^-} zhi dao wo shi [^] he jiu de.
 you know I F⁸ drink T

... zai ni sui ^{^-} Bu wei er zheng shi
 PreP you follow Bouvier legally
gai huan [^] xing shi de shi hou
 change surname MOD time

Both translations choose to interpret the connotative meaning of the above adverbial clause to the effect that the message "when we were getting married" and "you have been since renamed Bouvier" gets across clearly; but FDt2 keeps the information focus in place and uses the phrase that means "when you (accordingly) changed your surname to Bouvier legally" to gain the equivalent effect of the locution used in FDs that is not so explicitly expressed as FDt1 in IU(25) does.

13. JANET

SA(15)>

(27) ... That was **^not** **^^why** I married you.

.. Na ye bu shi wo he ni [^] jie hun de
 that just not be I and you marry MOD
^{^^} yuan yin .
 reason

... Wo bu shi [^] wei ^{^^} zhei ge jia gei ni .
 I not be for this marry to you

FDt1 has lost cohesiveness altogether here owing to its mishandling of the information in the last turn. The intent of Bouvier in making the simple point of "when we were married" by way of implying, putting his family name in focus, is apparently not fully perceived by the translator of FDt1; consequently, the direct translation of the deictic reference **that** in FDt1 for the above turn is deemed meaningless since the segment that literally means "you knew I drank" is the immediate related situation the pronoun referred to. In contrast, FDt2, being a Type 4 match, expresses in idiomatic Chinese the same meaning as intended by FDs, that is, to marry after the Bouvier name.

AP9>>

14. BOUVIER

SA(16)>

(28) ... So you ^{^^}never [^]wanted from me.

<p>..Ke ˊni ˊ jia ˋ gei ˊ wo ˊ yi ˊ hou ˋ .wo ˊ ˊ yi ˊ zhi ˋ ˊ</p> <p>But you marry to me since I all along</p> <p>ye ˊ mei ˊ you ˊ gai ˊ bian ˋ .</p> <p>even never change</p>	<p>... Na ˋ ni ˊ ˊ ˊ cong ˋ bu ˋ xiang ˊ ˊ de ˋ dao ˋ</p> <p>so you never intend get from</p> <p>wo ˊ shen ˊ me.</p> <p>me whatever</p>
---	---

By the same logic, FDt1 keeps harping on the topic of Bouvier's drinking and thus departs further from the on-going flow of the dialogue.

15. JANET

SA(17a)>

(29) ... That's ^not ^true.

..Zhe `^^bu `shi `shi `shi` this not be fact		... ^Bu `^^dui` not true
---	--	-----------------------------

As can be expected from FDt1, the reply above dangles between the last speech act and the next two segments, giving away the translator's uncertainty as to what is actually being talked about – otherwise the translation of FDt1 would have had no reason for being so wordy.

SA(17b)>

(30) ... I ^^want a husband.

... Wo `yao `de shi `yi `ge `^^zhang `fu, I want T ⁹ F a MSR husband		... Wo `^^xu `yao `yi `ge `zhang `fu I want a MSR husband
--	--	--

The pseudo-cleft structure *wo `yao `de shi`...* (what I want is...) used by FDt1 is unnecessary and the information focus is thereby misplaced

(31) ... A ^^family –

.. yi `ge `^^jia `ting` a MSR family		.. yi `ge `^^jia `ting` a MSR family
---	--	---

AP10>>

16. BOUVIER

SA(18a)>

(32) ..A ^^family!

..Hng, yi `ge `^^jia `ting` humph a MSR family		... yi `ge `^^jia `ting`! a MSR family
---	--	---

The space-taking interjection would not have been used in FDT1, if the role that prosody plays in indicating the speaker's attitude and emotional state had been fully recognized.

SA(18b)>

(33) ... ^{^^}All you want to do

<p>..Ni ^ˇxiang ^ˇde ^{^^}wu ^ˊfei ^ˇ shi ^ˇ</p> <p>you intend T nothing but F</p>	<p>... ^{^^}Wu ^ˊfei ^ˇ ni ^ˇshi ^ˇxiang ^ˇ</p> <p>nothing but you F intend</p>
--	---

FDT1 above intends to lay stress on wu ^ˊfei ^ˇ (nothing but) through the emphatic pattern "what you want is nothing but..." with no regard for the new information locus in the IU. This much-favoured strategy of using the pseudo-cleft sentence for thematic saliency as evidenced in the FDT1 version of the teleplay, reflects one of the major differences between the FITNIATS theory and the traditional approach in that the latter relies on syntactic means rather than prosodic devices to accentuate new information.

(34) .. is [^]claw your ^{^^}way | to the ^{^^}top of [^]society

<p>..yao ^ˋpa ^ˋdao ^ˇ ^{^^}shang ^ˋceng ^ˋshe ^ˋhui ^ˋqu ^ˋ ;</p> <p>want climb ASP top of society LOC</p>	<p>... ^{^^}li ^ˋyong ^ˋwo ^ˋpa ^ˋjin ^ˇ ^{^^}shang ^ˋceng ^ˋ</p> <p>use me claw into top of</p> <p><u>she ^ˋhui ^ˋ li,</u></p> <p>society LOC</p>
---	---

The approach underlying the FDT2 version rejects the practice of translating each segment in isolation; instead, it integrates decisions about

information with those about interaction in terms of seeking TE in both dimensions. In the above translation, FDt2 adopts the expansion strategy by adding to the segment *li`yong`wo`* (meaning in this context "to take the advantage of marrying me") to achieve fitness at both prosodic and organic levels.

(35) .. because your ^father came from ^^nowhere -

..*yin`wei`ni`de`fu`qin`bu`zhi`dao`shi`lai`*
 because your father not know F come
zi`^^he`fang`de`..

LOC which direction MOD

... *yin`wei`ni`^fu`qin`bu`zhi`shi`*
 because your father not know be
 ^^*shen`me`-*

what

Mechanically translated from the idiom " **come from nowhere**" , the poetically-sounding Chinese phrase in FDt1 fails to represent this remark of a demeaning nature functionally, since it has lost the contemptuous tone and the biting force carried in the verbal slap. FDt2 uses a corresponding Chinese idiom *bu`zhi`shi`shen`me`* (a nobody) which is usually followed by the insulting reference *wen`yir`* or *dong`xi`* (stuff, despicable creature) to finish with. Thus it bears the formal and functional resemblance to the original.

17. JANET

SA(19)>

(36) .. At least ^my father made his ^^own money!

..Qi ma wo fu qin de [^] [^]qian shi ta ⁻
at least my father MOD money F him

[^]zi ji zhuan de.
self make

... Zhi shao [^]wo fu qin kao [^] [^]zi ji ⁻
at least my father by self

zheng qian [^]
earn money

Resorting to the emphatic **shi**... **de** construction unnecessarily, FDt1 not only upsets the information flow from the original end-focus on **zi ji** (own) to the mid-sentence focus on **qian** (money), which is given both syntactic saliency and prosodic prominence; but also has to use three excessive syllables for this unit. FDt2 in comparison conveys faithfully the original meaning with the right NI focus and an equal number of syllables.

AP11>>

18. BOUVIER

SA(20)>

(37) ... ^{^^}Mine didn't?

.. Nan dao [^] [^]wo de bu shi ma [?]
didn't mine not so Q

... [^]Wo fu qin bu shi [?]
my father not so

Although **wo de** is similar to the possessive pronoun mine in representing both people and object, it is unusual in Chinese to use it as the subject to refer to a person. FDt1 needs to improve on this account, i.e., **wo de** should be used as an adjective pronoun to be followed by **fu qin** (father) to sound natural. On another account, to be eligible as an

acceptable dubbing line, it should get rid of needless words so that the FDs form is respected in terms of the position of the stressed word and the length of the IU.

19. JANET

SA(21)>

(38) ... And he doesn't ^{^^}lie about our family [^]history

.. <u>Guan • yu</u> <u>wo' mende</u> ^{^^} <u>jia • shi</u> ,		... <u>Ta • ye</u> <u>bu</u> ^{^^} <u>bian • zao</u> <u>shen' me</u>
as to our family history		he either not make up what
		<u>liao' bu qi' de</u> [^] <u>jia • shi</u>
		extraordinary family history

Here again a word order problem with FDt1 with regard to translating and placing a PP in a sentence. Without exception, FDt1 chooses to left-dislocate the translations for **about our family history** and the next PP, leaving the key word **lie** far behind the original position.

(39).. like ^{^^}your father-

.. <u>ta</u> <u>bu</u> <u>hui</u> <u>xiang</u> ^{^^} <u>ni' fu qin na</u> <u>yang</u>		... <u>xiang</u> ^{^^} <u>ni' fu qin</u>
he not good at like your father that way		like your father
^{^^} <u>sa • huang</u> ..		
lie		

(40) ... ^{^^}shamelessly [^]making up a story

.. <u>na</u> <u>yang</u> ^{^^} <u>hou yan wu chi' de</u> [^] <u>bian • zao</u>		... ^{^^} <u>wu chi' de</u> ^{^^} <u>sa • huang</u> <u>shuo</u> <u>shen' me</u>
that way shamelessly make up		shamelessly lie say what

Overlooking the adequacy of prosodic means in stressing the syllables for **shamelessly**, FDt1 employs lexical reinforcement (two synonymous

characters added before *wu'chi* to form a set phrase) to underscore the adverb; while the jamming of the preceding *na yang* (so) is a follow-up parallel to the previous one, only to make the whole string of words sound highly constructed.

(41) .. that you're descended from ^French ^aristocracy -

<p>.. <i>ni men shi</i> ^<i>Fa guo</i> ^<i>gui zu</i> de you be French aristocracy MOD ^<i>hou yi</i> ... descendent</p>	<p>... <i>ni men de zu shang shi</i> ^<i>Fa guo</i> your ancestor be ^French ^<i>gui zu</i> aristocracy</p>
---	--

There is no reason why *gui zu* (aristocracy) should not retain its end-focal position for better effect in dubbing, even though the PP has to be turned into a subject complement in FDT2.

AP12>>

20. BOUVIER

SA(22)>

(42) ... The Bouvier ^did ^descend from French aristocracy.

<p>.. <i>Wo men Bu wei er</i> ^<i>ben lai</i> ^<i>jiu shi</i> we Bouvier as it was just be ^<i>Fa guo</i> ^<i>gui zu</i> de ^<i>hou yi</i>. French aristocracy MOD descendant</p>	<p>... <i>Bu wei er</i> ^<i>que shi shi chu sheng</i> Bouvier indeed be descend from ^<i>Fa guo</i> ^<i>gui zu</i>. French aristocracy</p>
--	---

Had FDT1 adopted a different approach that is oriented to spoken language translation and takes translating prosody as part of the FDT task, the above segment would have been less wordy by saving

the words *wo`men* (we) and *ben`lai`* (as it was) that are damagingly gratuitous.

21. JANET

SA(23)>

(43) ... The Bouviers were ^{^^}no=thing

.. *Bu`wei`er`yi`jia`zi`^{^^}shen`me`ye`*
 Bouvier whole family what at all
bu`shi`
 not be

... *Bu`wei`er`jia`^{^^}shen`me`dou`*
 Bouvier family what all
bu`shi`
 not be

The lengthening of nothing as articulated on the original soundtrack makes room for the extra three syllables after *shen`me* opted by both Chinese versions, since the whole string of words is the best choice for rendering this unique indefinite pronoun. The difference between them here, though minor, lies in the important consideration as regards choosing words that suit the spoken language context more or less. Words chosen by FDt2 such as *dou`* (all) and, in the next IU, *jin`* (completely) and *yi`qun`* (a bunch of) are more characteristic of the colloquial lexis than their counterparts in FDt1, viz., *ye`*, *zhi`* and *yi`xie`*.

(44) .. but a bunch of ^{^^}filthy ^{^^}cow ^{^^}farmers!

.. *zhi`shi`yi`xie`^{^^}ang`zang`de`*
 only be one MSR dirty MOD
^{^^}*xiang`ba`lao`!*
 country bumpkin

... *jin`shi`yi`qun`^{^^}ang`zang`de`*
 all be one MSR dirty MOD
^{^^}*xiang`ba`lao`!*
 country bumpkin

AP13>>

22. BOUVIER

SA(24)>

(45) ... For ^{^^}better or ^{^^}worse,

.. <u>Bu</u> <u>guan</u> <u>shi</u> ^{^^} <u>hao</u> <u>shi</u> ^{^^} <u>huai</u> ;		... <u>Shuo</u> ^{^^} <u>hao</u> <u>shuo</u> ^{^^} <u>huai</u> ;
no matter be good be bad		say good say bad

This is further evidence of the fact that FDt1 tends to use words lavishly with little differentiation made between literary translation and film translation.

(46) .. we [^]are what we ^{^^}are.

.. <u>wo</u> <u>men</u> ^{^^} <u>jiu</u> <u>shi</u> <u>wo</u> <u>men</u> .		.. <u>wo</u> <u>men</u> [^] <u>jiu</u> <u>shi</u> ^{^^} <u>gui</u> <u>zu</u> .
we still be we		we still be aristocracy

Idiomatic Chinese notwithstanding, FDt1 is too vague to match FDs, since the wh-clause **what we are** stands for **aristocracy**, not **we**. FDt2, by allowing more freedom in the rendition, prioritizes achieving prosodic and organic equivalence and gains the objective thereby.

23. JANET

SA(25)>

(47) ... I ^{^^}can't accept [^]that.

.. <u>Wo</u> ^{^^} <u>bu</u> <u>neng</u> <u>jie</u> <u>shou</u> <u>Wo</u> ^{^^} <u>wu</u> <u>fa</u> [^] <u>ren</u> <u>shou</u> .
I not can accept		I can't bear

FDt2 is a stronger version than FDt1 through careful choice of words to restore the meaning of the original speech act.

Summary of SAS#3

This SAS contains 23 IUs in 12 turns, the longest one in the whole dialogue of this scene. The sequence centres around the low opinion the couple have of each other's origin and suggests mounting tension of the relationship in the irreconcilable situation. FDt1 conveys the topic and the atmosphere accordingly; but, as noted in the above analysis, it fails in varying degrees to achieve the equivalent effect in all six dimensions of the FITness criteria. The following statistic summaries support this conclusion by providing evidence that shows the discrepancies of the informational structure make-up between FDt1 and FDs that affect the very basis of the audio-visual effect of the dubbed dialogue and the cohesion of its interactional structure.

TURN		12	13	14	15	16	17	18	19	20	21	22	23	SAS#3 TOTAL
NUMBER OF														
FDs	Syll.	24	8	8	12	29	10	3	40	13	15	10	5	177
FDt1	Diff.	-0.5	+3.5	+7	+4.5	+3.5	+2	+3	-5.5	+2	+4.5	+1	0	+25 (14%)
	Syll.	23.5	11.5	15	16.5	32.5	12	6	34.5	15	19.5	11	5	202
FDt2	Diff.	-1.5	+0.5	+1.5	+0.5	-1.5	-0.5	+1.5	-8	-1	+3	-0.5	0	-6 (3.4%)
	Syll.	22.5	8.5	9.5	12.5	27.5	9.5	4.5	32	12	18	9.5	5	171

Table 13

Sample 1 - SAS#3:
Number of syllables in each turn and the difference between FDs and FDt

TURN		12		13	14			15			16			17
IU		25	26	27	28	29	30	31	32	33	34	35	36	
NI	<i>D</i>									X				
	<i>M</i>											X	X	
	<i>DM</i>	X	X	X	X	X	X							
TOTAL		2		1	1	2			2			1		
%		100%		100%	100%	67%			50%			100%		

18	19					20	21		22		23	SAS Σ=
37	38	39	40	41	42	43	44	45	46	47	23	
					X						2	
											2	
	X	X		X					X		10	
-	3					1	-	1		-	14	
0	75%					100%	0	50%		0	61%	

Table 14

Sample 1 - SAS#3:
Instances of loss of NI synchronicity with the original timing obtained in FDt1

The above tables show that FDt1 has used syllables in excess of 14% on the average of the total number contained in the original time span available to a

turn, and betrayed the original NI in 61% of all the IUs in this SAS, of which 71% are both dislocated and misplaced.

SAS#4>>>

AP14>>

24. BOUVIER

SA(26)>

(48) ... The ^{^^}question then [^]is,

.. <u>Ni</u> <u>de</u> ^{^^} <u>yi</u> <u>si</u> <u>shi</u> `		... ^{^^} <u>Wen</u> <u>ti</u> ` <u>na</u> <u>jiu</u> <u>shi</u> `
your intention be		question then just be

FDt1 uses too free a translation to state plainly and misleadingly what is intended by this utterance and the next, leaving out the undertone of Bouvier's sustained ego and his incapability to assume power over the deteriorating relationship.

(49) ..how do you choose to [^]live your ^{^^}life?

.. <u>ni</u> <u>xiang</u> ^{^^} <u>chong</u> <u>xin</u> [^] <u>xuan</u> <u>ze</u> ` <u>dui</u> <u>ma</u> ?		... <u>ni</u> <u>yao</u> <u>zen</u> <u>me</u> <u>qu</u> <u>guo</u> <u>ni</u> <u>de</u> ^{^^} <u>ri</u> <u>zi</u> ?
you want again choose TAG-Q		you will how to live your life

Thus, in back translation, the whole speech turn for FDt1 reads: " What you mean is: you want to make your choice again. Is that right?" . Judged against the FITness criteria, it fails to gain TE at all six levels, because:

(1) semantically, the key elements of the speech turn are misrepresented: **the question ≠ what you**

mean; and how to choose to live your life ≠ re-make your choice;

(2) the original question is expressed in the form of a statement in a totally different structure and word order;

(3) the original rhythm is lost completely and the information focus indicated by the accentuated words in both IUs is a far cry from the original in timing and in location;

(4) The colloquial idiom **to live one's life** is replaced by a highly equivocal phrase with undue formality, which sounds inconsistent in style in the context;

(5) Bouvier's arrogance and cynical nature as reflected in this slur are missing from the translation which misleadingly strikes the audience as being an earnest, genteel confirmation made by a well-meaning person in a well-intentioned effort; and

(6) there is a lack of cohesiveness between this speech act and the ensuing ones, on account of the excessive liberty taken in translating Bouvier's question that is turned into an assumption that Janet will "make a choice again" (meaning "to end this marriage"), which is confirmed by the definite answer in the next turn. This gives rise to inconsistency and incoherence in the following question raised by Bouvier and the message hinted by Janet in the last speech act of this scene (SA 29b), i.e., "if we can't make up, I will live by myself", as these utterances are made redundant and irrelevant by the mistranslation here.

25. JANET

SA(27)>

(50) ... ^^Exactly.

..^^Zheng`shi`zhei`ge`yi`si.
just be this MSR meaning

... ^^Mei`cuo`.
not wrong

FDt1 here gives another instance of indulging in sentence-wide free translation to such an extent that the outcome is utterly uncalled-for in dubbing. Considering the fact that FDt1 is a verbatim transcript of the dubbed TV series which have been repeatedly transmitted and videotaped for the Chinese viewers, it is a regrettable fact that the translation can be so heedless of the basic synchronization demand on dubbing from time to time. As pointed out earlier, this serious problem of being profusely wordy is due to the translator's total negligence in translating prosody under the influence of the traditional literary approach that simply treats film dialogue text as written dramatic literature.

AP15>>

26. BOUVIER

SA(28)>

(51) ... ^^Elevated like ^I do?

..Xiang`wo`nei`yang`,`guo`^^kuai`le`
like I that way live happy

de`ri`zi`?
MOD life

... ^^Kuai`kuai`Huo`huo`xiang`wo`
Elevated like I

zhe`yang`?
this way

FDt2 uses a colloquial expression for **elevated** without inverting the position of the Chinese equivalent for the PP (**like I do**) and it sounds natural and idiomatic. Despite its restructuring and expansion to gain the same effect, FDt1 does not sound any more so, but perhaps less. What it has lost is too valuable to ignore - what makes good dubbing: the original rhythm, timing and information flow.

(52) ... Or by the [^]book like ^{^^}you do?

<p>..<u>Hai shi</u> `xiang `^^ni `nei yang `.. kao `</p> <p>or like you that way by</p> <p>^^<u>shu</u>-<u>ben</u> `guo `ri `zi?</p> <p>book live life</p>	<p>...<u>Hai shi</u> `^<u>shou</u> `jiu `xiang `^^ni `?</p> <p>or conservative like you</p>
--	---

The exactly same translation method is adopted for this FDt1 segment as for the last, and the same problem of NI dislocation, with the difference only in having more excessive syllables here. In FDt1, the idiom **by the book** is literally translated into Chinese that requires a verbal phrase to follow as complement of the collocation, hence *guo ri zi* has to be added. Compared with the meaning translation in FDt2, the six-syllable phrase in FDt1 is not only less disdainful for the speech situation but also misleading (in Chinese, the phrase is most often used to poke fun at a bookworm).

27. JANET

SA(29a)>

(53) ... I choose to make a ^{^^}respectable life | for my ^{^^}daughters.

..Wo yao wei wo de ^{^^}nu er men
 I want for my daughters
xuan ze yi zhong ^{^^}gao ya de
 choose one kind graceful MOD
^{^^}shou ren zun jing de sheng huo .

	respectable	MOD	life
..	Wo yao	you yi zhong	^{^^} <u>shou ren</u>
	I want	get a kind	respec-
	<u>zu jing</u>	de	<u>sheng huo</u> <u>wei le</u> ^{^^} <u>nu er</u>
	table	MOD	life for daughter

The lexical as well as syntactic arrangement of FDt1 for this statement put three items of information in the foreground: nu er men (daughters), gao ya de (graceful) and shou ren zun jing de (respectable), which are barely managed to sound as such in a breathless "word race". Such violation of the natural law of spoken language in the translation explains the cause of the typical speaking style designated to most Chinese dubbed films. FDt2, respecting the one-NI per IU rule, has rightly identified the information focus with no unnecessary addition (such as gao ya de) and inversion (the **for..** PP) and achieved the desirable equivalent effect.

SA(29b)>

(54) ... If ^{^^}necessary,

..^{^^}Bi yao de shi hou ;
 necessary MOD time

...	You	^{^^} <u>bi yao</u> ;
	there be	necessity

For reasons not justifiable, FDt1 tends to stereotype the ill-conceived western way of talk by sounding formal and consequently verbose, as the translation of the above IU confirms.

(55) ..I^do by ^^myself.

..wo <u>ke</u> <u>yi</u> ~ ^^ <u>zi</u> <u>ji</u> ~ ^^ <u>yi</u> <u>ge</u> <u>ren</u> ^ <u>guo</u> `		... wo ~^ <u>quan</u> ^ <u>kao</u> ^^ <u>zi</u> <u>ji</u> `
I can self one MSR person live		I all rely on self

Since I do in FDs stands for to choose a **respectable life**, the possibility of terminating the marriage has not been touched upon until this point (compare the last point of the above comment made on IU 49). Leaving aside this conflict and the recurring problems of misplacing information focus and running overtime in this segment, FDt1 turns out an erroneous translation in that by saying zi ji ~ yi ge ren ^ guo ` (a frequently-used Chinese saying, meaning "to live by myself alone"), Janet actually is giving up her daughters rather than creating a life for them by herself, as she asserts in the previous utterance.

Summary of SAS#4

Tables 15 and 16 below confirm the ruinous tendency that has been addressed in the previous SAS summaries concerning FDt1: to take too much liberty of "domesticating" (Hatim 1996) the SL sentences

to the extent of putting into oblivion the demands on translating for dubbing. For this short sequence, FDt1 has packed 32% additional syllables into the optimal range of phonetic substance set up by FDs and mishandled 75% of all the IUs in terms of disordering the original information flow.

TURN NUMBER OF		24	25	26	27	SAS#4 TOTAL
FDs	<i>Syll.</i>	13	3	14	24	54
FDt1	<i>Diff.</i>	-1	+2.5	+6.5	+9.5	+17.5 (32%)
	<i>Syll.</i>	12	5.5	20.5	33.5	71.5
FDt2	<i>Diff.</i>	+1	-1	-1	-1	-2 (3.7%)
	<i>Syll.</i>	14	2	13	23	52

Table 15

**Sample 1 - SAS#4:
Number of syllables in each turn and the difference between FDs and FDt**

TURN		24		25	26		27		SAS Σ=	
IU		48	49	50	51	52	53	54	55	8
NI	<i>D</i>				X				X	2
	<i>M</i>									0
	<i>DM</i>	X	X			X	X			4
TOTAL		2		-	2		2			6
%		100%		0	100%		67%			75%

Table 16

**Sample 1 - SAS#4:
Instances of loss of NI synchronicity with the original timing obtained in FDt1**

The sequential discussions of the translation problems observed in FDt1, being counterpointed by FDt2's close formal and functional match to the original, have initially proved that the implementation of a correct approach to translating for dubbing distinguishes a quality translation and a problematic one; and that the frequently occurring problems in FDt1 are not isolated or accidental instances but common ones that exist widely in this teleplay as well as in other Chinese dubbed audiovisual products made for the cinema and television, because it qualifies as a typical example that represents the consequence of using the sentence-by-sentence, TL-oriented, genre-indiscriminate translation methodology. These points will be seen more clearly through the overview of the findings in the end-of-scene summaries and the general discussion of the whole teleplay.

5.2.3 Discussion of the Results

Through the analysis of our data as Sample 1, all the SAS summaries have reached a similar conclusion that FDt1 misrepresents FDs in two distinct regards, which can be viewed now in the perspective of the whole scene. First, for each of the SAS's, FDt1 has exceeded the syllable number contained in

their relevant source segments by 17.6 % on average and tended to use considerably more syllables for every turn than the original. In contrast to FDt1, FDt2 has been in conformity with the FDs wordage length (approximate to the IU), with a difference of only 2.3% less the source syllable number for the whole dialogue segment (*Sc. 1-1.4*).

Second, in breach of the law of spoken language as a single-NI-focused incremental process and in defiance of the interdependency between the spoken words and the accompanying paralinguistic/ prosodic message, both of which are vital to the word-picture coordination in dubbing, FDt1 has either dislocated or misplaced the information focus in each segment between pauses to such an extent that out of 55 IUs in this dialogue scene, 61.8% have lost the right information focus. Opposite to such disregard for the original information structure, FDt2 has kept a high-degree of equality with FDs throughout in retaining each and every NI in situ. Table 17 is a combined summary of these observations for the entire scene.

<i>Jackie Sc. 1-1.4</i>		SAS#1	SAS#2	SAS#3	SAS#4	TOTAL
# of	FDS	114	84	177	54	429
Syll.	FDT1/FDT2	137/107	94/89	202/171	71.5/52	504.5/419
Difference		23/-7	10/5	25/-6	17.5/-2	75.5/-10
Difference (%)		20.2/-6.1	11.9/6	14.1/-3.4	32.4/-3.7	<u>17.6/-2.3</u>
Total # of IUs		14	10	23	8	55
NI loss in FDT1		10	4	14	6	34
NI loss (%)		71	40	61	75	<u>61.8</u>

Table 17

Sample 1: Differences in syllables used between FDS and FDT and NI failure in FDT1

To further look into the two interrelated problems in FDT1, a graphic representation (Figure 21) showing the differences in syllabic density of FDS, FDT1 and FDT2 by the SAS indicates more clearly the wordiness of FDT1 and a similarity between FDT2 and FDS in length. The figures on top of the FDT bars stand for the percentage of syllables exceeding or below the syllable numbers contained in FDS' four SASs.

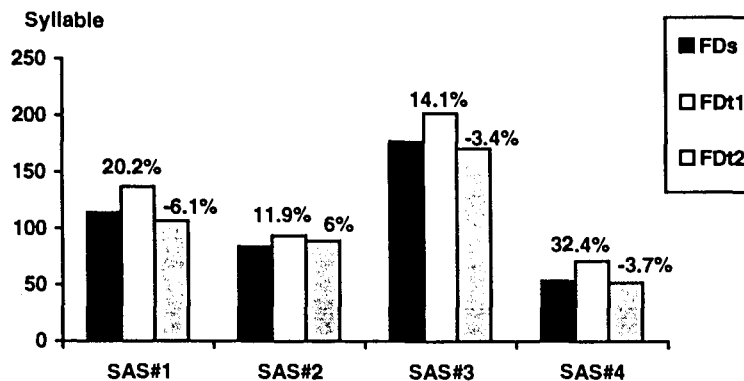

Figure 21

Sample 1: Syllable count by speech act sequence and discrepancies in percentage between FDS and FDT

On the other hand, causes of FDt1's mishandling of the new information in each IU need to be further identified. While the placement of NI on the wrong lexical item in each IU is generally caused by the translator's and, occasionally, the dubbing performer's, misidentification of the original information flow, the dislocation of the NI because of the imposed new word order that shifts the information focus out of place is undoubtedly the translator's responsibility. As tallied in Table 18, the frequent recurrence of the problem due to the four main factors of FDt1's methodological unfitness further proves its impuissance to achieve the equivalent effect in the audiovisual translation of spoken language.

It needs to be pointed out that the NI dislocation problem can be caused by more than one factor, or may be the consequence of a combination of different choices across the types made by the translator; for example, opting for inversion of the word order because of the SC factor may be complicated by further changing the original unmarked structure into a cleft sentence in Chinese. Here only the main factor is singled out

for consideration as the cause for the problem IU in question.

SAS	DISLOCATION TYPE				D (incl. DM) Total	M (excl. DM)	TOTAL
	Motivated		Constrained				
	PS	MS	SC	ID			
1	4	1	2	2	9	1	10
2	-	1	3	-	4	-	4
3	4	3	5	1	12	2	14
4	1	1	2	1	6	-	6
TOTAL	9/31	6/31	12/31	4/31	31/34	3/34	34/55
%	29%	19%	39%	13%	91%	8.8%	61.8%

N = 55

Abbreviations

PS: poor style, TL-oriented translation, etc.; *MS*: unnecessary marked structures; *SC*: FDs syntactic constraints; *ID*: idiomatic or culture-specific expressions in FDs; %: percentage of the total in the upper line after the /

Table 18
Sample 1: Causes of NI dislocation and their relative frequency in FDT1

The dislocation of the NI results from permutations of the FDs word order either motivated by the translator's preferred arrangements or compelled by the translator's available solutions to translatability obstacles. Of the the first type, there are two subdivisions, namely, *PS* and *MS*. The former means poor style on account of its literary or highly-constructed, and mostly wantonly expanded, rendering of the spoken text. It is TL-oriented translation after the grammar of written Chinese with little regards for the demands on the dialogue dubbing. *MS*, or marked structure, is the other common cause of translator-initiated NI

dislocation As illustrated in the last section, the translator of FDt1 tends to overlook the information-giving function of prosody (intonation and stress) and resort to syntactic means to make the translation look emphatic enough to match the English original. Consequently, unnecessary use of a marked structure, instead of an otherwise unmarked but more faithful translation, is opted for. Table 18 has shown that PS and MS together take up **48%** of the causes to account for the motivated type of dislocation, with the former being a more obsessing source of the problem.

The other type of dislocation is mainly caused by the translator's poor solutions to certain translation problems stemming from the essential interlingual or cross-cultural differences where it is nearly impossible to either transfer the original syntactic structures into idiomatic Chinese without having recourse to inversion, or convert some colloquial or culturally-alluded expressions into understandable Chinese without overall adaptation. The two common reasons that force the translator to get around the challenge of formal correspondence at the expense of discarding the original information structure are labelled as SC and ID in the present study.

Syntactic constraints (*SC*) refers particularly to the fact that the structure of a FDs sentence containing a post-positive prepositional phrase, a non-finite verbal phrase (e.g., an infinitive or participial phrase), or a relative or adverbial clause, is such a far cry from the corresponding Chinese syntax that inversion of the word order is in most cases inevitable in order to render the English original into grammatically acceptable Chinese. Contrary to this intention, the outcome of the restructuring generally finds FDT1 sounding unnatural and confusing as spoken language because of its plannedness and loss of the natural information distribution in an utterance. Of the four identified causes, SC turns out to be the strongest one that accounts for 39% of all the 31 instances of the NI dislocation. In Sample 1, this is 3 times higher than the occurrence frequency of *ID*, the other seemingly insurmountable obstacle – to translate certain idiomatic expressions (especially those which are language- or culture-specific) without making over the original structure into a new one. Together, these two causes of the constrained type make another major source of the dislocation problem (52% out of all the instances of the dislocation in FDT1, Sample

1), slightly more haunting than the motivated causes.

The total number of the dislocation instances including DM (dislocation and misplacement of NI occurring in the same IU) accounts for 91% of the sum total of the NI loss (in 31 out of the 34 pertinent ill-translated IUs in FDt1, Sample 1), which reveals the severity of a FDT malpractice in FDt1 as the result of using the traditional sentence-based, genre-undefinable approach to dubbing.

The NI loss, either as a result of dislocation or misplacement, or both, that causes the missing of the right information focus to the majority of the segments of Sample 1 (61.8%), poses a serious quality problem in FDt1. This problem, however, could have been resolved or largely avoided if the FITNIATS approach had been adopted. As demonstrated in FDt2, all the obstacles to translatability have been overcome successfully and there is no NI loss problem detected whatsoever. The translation quality of FDt1 is unquestionably inferior to FDt2 just on this account alone, not to mention the mistranslations found in FDt1, which, although not isolable from the influence of the disputable methodology, are largely due to the translator's

linguistic and communicative competence as well as translation skills.

The following is a summary of the instances of incorrect or inappropriate translation in FDt1 as pointed out in the previous section. Collectively referred to as mistranslations, they are divided into three basic categories of mismatch with the original, viz., *linguistic* (including wrong interpretation of an idiom or the socio-cultural connotations of an expression or lexical item), *stylistic* (including wrong register and unacceptable style for the spoken channel) and *pragmatic* (including errors that are directly accountable for misrepresented speech act function, corrupted interactional structure and loss of coherence). To indicate the erroneous extent to which a mistake is committed, three kinds of mistranslation are distinguished: totally wrong (*W*), partially incorrect (*P*) and the whole semantic entity missing or discarded (*M*).

N = 55

SAS	Linguistic	IU	Stylistic	IU	Pragmatic	IU	TOTAL		
							W	P	M
1	1W	(6)	1P, 1W	(3,14)	-		2	1	-
2	1M	(18)	1M	(22)	2P, 1W	(16,19,21)	1	2	2
3	1W	(28)	-		1W	(27)	2	-	-
4	-		-		1W, 3P	(48,49,52,55)	1	3	-
Σ	3 (21.4%)		3 (21.4%)		8(57.1%)		14 (25.5%)		

Table 19

Sample 1: Types of mistranslation in FDt1

In this selection of the dialogue that consists of 55 IUs, more than a quarter (25.5%) of them contain a translation error of some kind. A majority of these 14 mistranslations found in FDt1 (57.1%) are related to unfaithful rendering of the relevant *pragmatic* functions intended by FDs, an indication of misunderstanding of the dialogue in the informational and interactional dimensions; whereas the considerably high percentage of errors of the *linguistic* and *sylistic* categories (42.8%) provides further evidence of the quality problem of FDt1. Altogether, there are 6 places in Sample 1 where the translator of FDt1 has failed outright to deliver the correct message.

In sharp contrast, FDt2 not only is free from any betrayal of the original propositional or illocutionary meanings, but also has successfully achieved a high degree of formal and functional match with FDs in Sample 1.

5.3 Sample 2: *Estrangement*

The second sample for analysis is the dialogue between Jackie and Jack (JFK) in *Scene 13, Act 1, Part 2* of the teleplay. For the first time in the story, it unveils a clashing verbal exchange between the couple as their marriage is in trouble.

The following analysis of FDs and the ensuing examination of FDt's translation quality will proceed as in Sample 1, but with less detailed explanation of the steps taken in the actual process.

5.3.1 Analysis of the Source Text

This scene takes place in a hospital room five days after Jackie's emergency Caesarean in which she lost her baby. Jack just has just come back from a lingering overseas trip in Italy, where he has been seen in the company of a young woman. Jack apologizes for his lateness when he starts the dialogue with his frail wife sitting up in bed.

The Scene

"Estrangement" sums up the topic of this scene, throughout which the atmosphere is tense and at times stifling as the relations between Jackie and Jack have come to the verge of alienation. Jackie sets the tone of the dialogue and it remains to be serious, cold and sometimes vindictive. As in Sample one, there is also an irreconcilable but "cooled-off" ending after the escalating of the conflict.

The Speech Act Sequences

There are 22 speech acts delivered in 4 sequences.

[Jackie Sc. 2-1.13]

JACK: I should've been here.(1)

JACKIE: I failed you.(2)

JACK: No, Jackie – (3)

JACKIE: [steely] And you failed me...

[Her voice stops him.]

JACKIE: ... as a husband. A friend. Someone I thought I could trust.(4)

JACK: I know – (5)

JACKIE: You don't know.(6a) You have no idea what I've been through.(6b) I don't even think you care.(7)

>>>SAS#1//

JACK: Did they give you anything for the pain?(8)

JACKIE: Yes.(9a) But it doesn't help.(9b) Your sister Pat had a baby two days ago ... (10)

JACK: I heard. (11)

JACKIE: And Ethel's due next month. She won't lose her baby. (12)

JACK: Come on, come on, now. This isn't some kind of race – (13)

>>>SAS#2//

JACKIE: It's what Kennedy wives are expected to do. Make babies, make politics ... and turn the other way when it comes to their husbands' indiscretions. (14a) [eye confrontation] Guess I've failed at all three. (14b)

JACK: What do you mean? (15)

JACKIE: You forget ... I grew up with one of the greatest philanderers of all time. I know exactly how it's done, Jack.(16)

>>>SAS#3//

JACK: Maybe I should start spending more time at home – (17)

JACKIE: We don't have a home. (18) I want to live with my mother in Newport.(19)

JACK: Wait a minute. Wait a minute. (20a) I've ... I've lost my daughter. I've lost ... you too ... you know. Now suddenly I'm losing my wife.(20b)

JACKIE: Not so sudden, Jack. Not so sudden. It actually took five days.(21) Five days of lying here alone during the lowest time of my life, needing my husband to be with me finally realisinghe never will be.(22)

>>>SAS#4//

[Cut out]

Each SAS contains the following information about the topic, the discourse function and AP status:

SAS #1: (1) - (7)

Topic: Jackie expressing her disappointment in Jack

Function: Evoking a topic

Adjacency pair status:

AP1 [(1)-(7)]: AAP, UAP; AP2 [(2)-(3)]:AAP, TAP; AP3 [(4)-(5)]: CAP_A, TAP;

AP4 [(5)-(6)]: CAP_P, TAP; AP5 [(7)-(7)]: CAP_A, UAP

SAS #2: (8) - (13)

Topic: Contrasting her situation with Jack's sisters'

Function: Holding on her topic

Adjacency pair status:

AP6 [(8)-(9)]: AAP, TAP; AP7 [(10)-(11)]: AAP, TAP; AP8 [(12)-(13)]:CAP_A,

TAP.

SAS #3: (14) - (16)

Topic: Complaining about her circumstances

Function: Focusing on the issue

Adjacency pair status:

AP9 [(14)-(15)]: CAP_A, UAP; AP10 [(15)-(16)]: CAP_P, TAP.

SAS #4: (17) - (22)

Topic: Jackie justifying her decision to separate

Function: Terminating the conflict

Adjacency pair status:

AP11 [(17)-(18)]: AAP, TAP; **AP12** [(19)-(20)]: AAP, UAP; **AP13** [(20)-(21)]: CAP_A, TAP; **AP14** [(22)-(22)]: CAP_A, UAP.

The AP status with respect to the occurrence rate of each AP type as initiated by one or the other character in the dialogue is analyzed as follows:

Total # of Adjacency Pairs =14	AAP	%	CAP		%	TAP	%	UAP	%
			A	P					
JACKIE	3	21.4	6	1	50.0	5	35.7	1	7.1
JACK	3	21.4	-	1	7.1	4	28.6	4	28.6
TOTAL (% of total APs)	6	42.9	8		57.1	9	64.3	5	35.7

Table 20

Sample 2:

Number and percentage of types of adjacency pairs ascribed to each character

Table 20 provides telltale figures that can be interpreted as findings significant in the following respects:

- (1) In this dialogue, Jackie uses most of the initiating APs (9 out of 12, or 75% of the total number of AAPs and CAPAs in this dialogue), a clear indication of her determinate attitude and control of the topic flow.
- (2) The facts that, in total, there are equal numbers of AAPs and CAPAs (both take up 42.9% of the AP total) and more TAPs than

UAPs (at a ratio of 1.8:1) support the earlier observation about the general tone of the dialogue that carries hidden tension behind unconcealed coldness. Jackie is responsible for initiating most of the CAPs (7 times out of 8), an outcome of her unswerving insistence on making a stand; whereas the relatively high frequency of AAPs (considering the length of the dialogue) reflects the disharmony of the conversational parties. The more frequent use of TAPs, another gesture of the discouraging tempo of the dialogue, matches Jackie's calmness in having to alienate on the one hand and Jack's eagerness to pacify his wife on the other.

(3) Jack adopts a passive and somewhat elusive stance throughout the dialogue. This can be seen by the fact that he is in the speaker role only four times, (1), (8), (17) and (15). Although taking up the AAP may suggest one's active role or enthusiastic participation in a conversation, it may also serve to hide an evasive or defensive posture. In this dialogue, Jack initiates AAP three times; but all these speech acts are either used as the apologetic opening (see SA (1)) or a strategy to avoid getting into a conflict (SAs (8) and (17)). The only CAPP that brings him in a speaker role (SA (15)) is resulted from his timid resistance to the inexorable pressure from Jackie.

(4) On the other hand, consistent with his intention to be in a low key in the

dialogue, the four instances of UAPs he opts are not meant to be uncooperative. To SAs (7) and (22), he chooses not to confront Jackie's emotional whimper by either changing subjects or keeping silent; whereas SAs (15) and (20) are the only two contradictory responses to Jackie's hard-bitten remarks.

(5) Noteworthy is also the fact that Jack is interrupted four times by Jackie in his appeasing effort to elicit Jackie's forgiveness by signalling TAP and AAP. All the four relevant speech acts ((3), (5), (13) and (17)) his uses are cut short by her with four different types of APs. This is motivated by her contempt for and increasingly distant attitude towards Jack.

Having examined the AP structure and the SA in sequence, the analysis of the dialogue at the turn level will show more explicitly the interactional structure and the topic flow of this scene.

The Turn

A speech turn can accommodate more than one speech act and a speech act can function in more than one adjacency pair. This situation presents itself more frequently in this sample than the previous one.

Scene: Estrangement

Abbreviations — Ack(nowledge.) = Acknowledgement; Ans. = Answer;
Cmnd. = Command; Contr.= Contradiction; Que.= Question; State.=
Statement

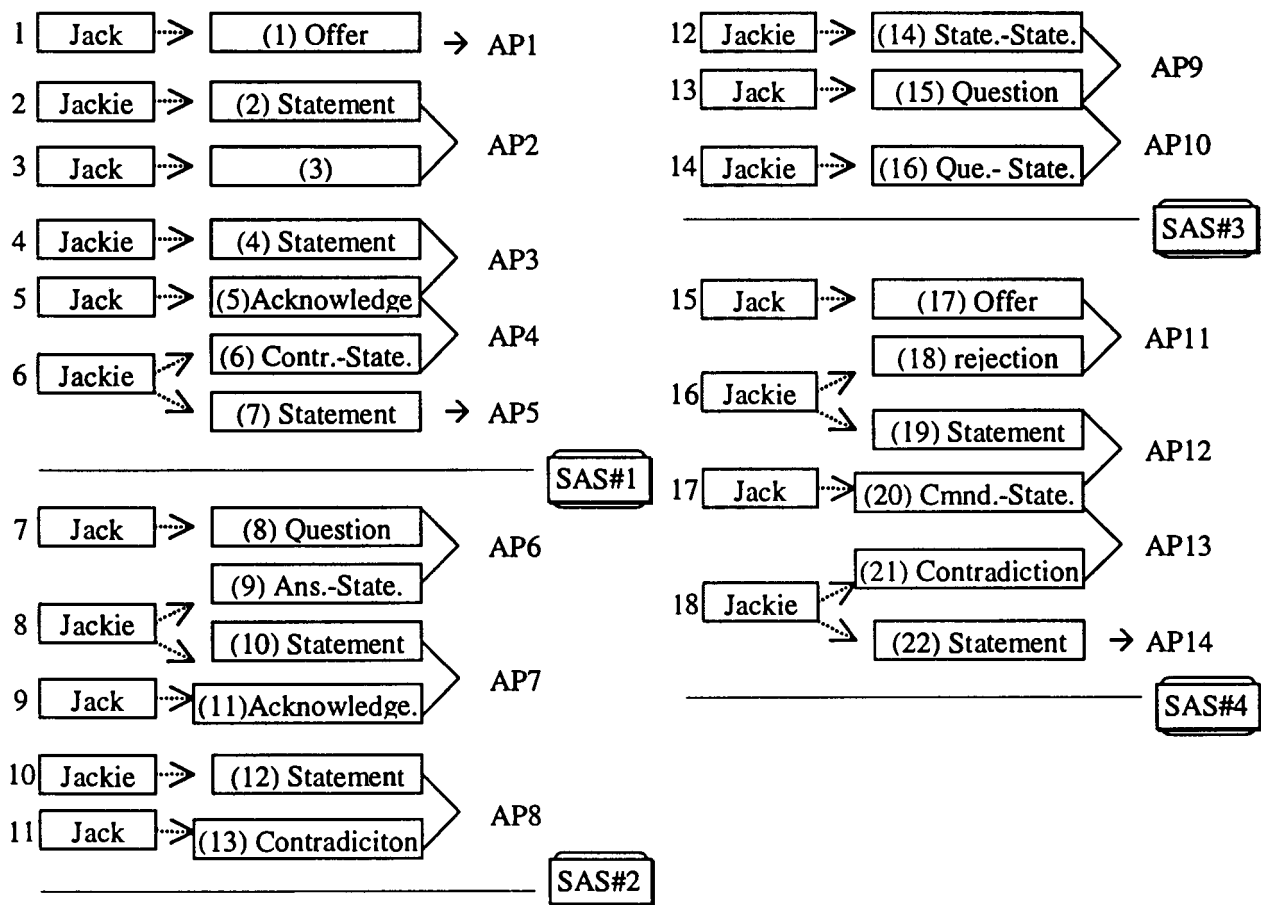

Figure 22

Sample 2: The performance of speech acts in the organization of the turn, AP and SAS

From our analysis of the speech act status of the 18 turns in this interaction, what is most significant about the speakers' attitudes reflected in the SA functions they intend in their turns is that Jackie in her 9 turns has used 11 speech acts functioned as "Statement" (Halliday *ibid.*), which is in sharp contrast to those in Jack's turns where there is only one instance that can be regarded as

"Statement" (SA 20b). This substantiates the conclusion from the previous analysis on the higher levels that Jackie is in control of the talk and her tone reveals a fair amount of apathy, displeasure and frustration which makes Jack's stance seem even shakier.

The Intonation Units

The segmentation of this dialogue into 46 intonation units shows the information structure of the utterances and their dynamic links to the higher functional segments. Apart from being informed by such analysis carried out in the same manner as with Sample 1, the findings that Jackie uses a series of intonation units to serve a single speech act more than Jack does are revealing. Each of the 4 speech acts Jackie uses (SAs 4, 14a, 16a and 22) is expressed by more than one IU (4, 5, 2, and 6 respectively), with the average number of IU being 4.25. This phenomenon clearly indicates Jackie's sustained holding of the floor out of her legitimate reasons for maintaining the power-relationship in her favour.

Here is the final result of the analysis of FDs (Sample 2) in a panoramic view (Table 21).

Jackie Sc.2-1.13

Scene: Estrangement

Tone: serious, cold, vindictive

TURN	SPEECH ACT FUNCTION	IU	CODED TRANSCRIPT OF THE DIALOGUE	Adjac. Pair STATUS	SAS TOPIC
1. JACK	(1) Offer →	1	... I ^should've ^^been here	AP1: AAP/UAP	SAS#1 Topic:
2. JACKIE	(2) Statement	2	... I ^^failed you	AP2:	Jackie
3. JACK	(3) Contradiction	3	.. ^^no ..Jackie –	AAP/ TAP	expressing her
4. JACKIE	(4) Statement	4	... And ^you failed ^^me.	AP3: CAP_/TAP	disappointment in Jack
		5	... As a ^^husband		
		6	... A ^^friend		
		7	.. Someone I ^thought I could ^^trust.		
5. JACK	(5) Acknowledge.	8	... I .. ^^know –	AP4: CAP_/TAP	Function: Evoking a topic
(JACK)	(5) Acknowledge.	8	... I .. ^^know –		
6. JACKIE	(6a) Contradiction	9	.. You ^^don't know.		
	(6b) Statement	10	...You have ^^no idea what I've ^been ^^through		
(JACKIE)	(7) Statement →	11	... I don't even think you ^^care.	AP5: CAP_/ UAP	
7. JACK	(8) Question	12	... Did they give you ^anything for the ^^pain?	AP6:	SAS#2
8. JACKIE	(9a) Answer	13	... ^^Yes	AAP/ TAP	Topic: Contrasting
	(9b) Statement		but it ^^doesn't ^help.		
(JACKIE)	(10) Statement →	14	... Your ^sister Pat had a ^^baby .. two days ^ago.	AP7: AAP/ TAP	her situation with Jack's sisters'
9. JACK	(1i) Acknowledg.	15	... I ^^heard.		
10. JACKIE	(12) Statement	16	.. And ^^Ethel's duel next ^^month.	AP8: CAP_/TAP	Function: Holding on her topic
		17	.. She ^won't ^^lose her baby –		
11. JACK	(13) Contradiction	18	.. ^^come on ^^come on, now		
		19	... This ^isn't some kind of ^^race.		
12. JACKIE	(14a) Statement	20	... It's what ^^Kennedy ^wives are ^^expected to do	AP9: CAP_/ UAP	SAS#3 Topic: Complaining about her circumstances
		21	... Make ^^babies.		
		22	... make ^^politics		
		23	... and tum the ^^other way		
		24	.. when it comes to their ^husband's ^^indiscretions		
	(14b) Statement	25	... Guess I've ^^failed at ^all ^^three		Function: Focusing on the issue
13. JACK	(15) Question	26	.. What do you ^^mean?	AP10: CAP_/TAP	
(JACK)	(15) Question	26	.. What do you ^^mean?		
14. JACKIE	(16a) Question	27	... You ^^forget		
		28	... I grew up with one of the ^greatest ^^philanderers of ^all ^^time		
	(16b) Statement	29	... I know ^^exactly ^^how it's ^done, Jack		

15. JACK	(17) Offer	30	... Maybe I should start spending ^^more ^time at ^^home ...	API1: AAP/ TAP	SAS#4 Topic: Jackie justifying her decision to separate
16. JACKIE	(18) rejection	31	... We ^^don't ^have a home		
(JACKIE)	(19) Statement	32	.. I want to live with my ^^mother in ^Newport	API2: AAP/UAP	Function: Terminating the conflict
17. JACK	(20a) Command	33	... ^^Wait a minute		
		34	.. ^^Wait a minute		
	(20b) Statement	35	.. I just ^got off a ^^plane		
		36	.. I've ^lost my ^^daughter		
		37	... ^^You ^too .. you know		
		38	... ^Now ^^suddenly		
39	.. I'm losing my ^^wife				
(JACK)	(20b) Statement	38	... ^Now ^^suddenly	API3: CAP _A /TAP	
		39	.. I'm losing my ^^wife		
18. JACKIE	(21) Contradiction	40	... ^^Not so sudden .. Jack	API4: CAP _A /UAP	
	(22) Statement →	41	.. It actually took ^^five ^days		
		42	... ^Five= ^days= of lying here ^^alone		
		43	... during the ^^lowest time of my ^life		
		44	.. ^^desperately needing my ^husband to be ^^with me		
		45	... and ^^finally realizing		
46	.. he ^^never ^will be.				

Table 21

Structural breakdown of the Scene *Estrangement* and the contextual relations between its components from both informational and interactional perspectives

5.3.2 Comparison and Evaluation

The presentation of the analysis of FDT in Sample 2 will proceed in the same manner as in Sample 1, except that comments on the translation problems of FDT1 at the IU level are made only where necessary. The summaries at end of each speech act sequence are also intended to look briefer through reducing repetition of the same points of the findings as made in the previous analyses.

SAS#1>>>

AP1>>

SA(1)>

1. JACK

(1) ... I ^should've ^^been here

..Wo ˊ^^zao ˊjiu ˊgai ˊzai ˊzhe ˊr.		.. Wo ˊgai ˊzai ˊ^^zher ˊde.
I early ASP should PreP here		I should PreP here ASP

FDt1 uses an emphatic grammatical structure at the expense of the original information structure.

AP2>>

SA(2)>

2. JACKIE

(2) ... I ^^failed you

... Wo ˊrang ni ˊ^^shi ˊwang ˊle.		... Wo ˊ ^^gu ˊfu ˊle ni ˊ.
I make you disappointed ASP		I fail ASP you

By choosing a different verb, FDT2 has kept the SL word order and avoided the NI dislocation caused by the passivisation in FDT1, which consists twice as many the original number of syllables.

SA(3)>

3. JACK

(3) .. ^^no ..Jackie -

... A ˊ, Jie ˊji ˊ.		... ^^Bu ˊ, Jie ˊji ˊ.
Ah Jackie		No, Jackie

AP3>>

SA(4)>

4. JACKIE

(4) ... And ^you failed ^^me.

... Ni ˊye ˊrang ˊ^^wo ˊshi ˊwang ˊle		... ^Ni ˊye ˊgu ˊfu ˊle ^^wo ˊ.
you too make me disappointed ASP		you too fail ASP me

FDt1 has the same problem as found in IU (2).

(5) ... As a ^{^^}husband

zuo`wei` ^^zhang`fu`
as husband

Zuo`wei` ^^zhang`fu`
as husband

(6) ... A ^{^^}friend

.. zuo`wei`yi`ge` ^^peng`you`
as one MSR friend

.. ^^peng`you`
friend

The damaging repetition of zuo`wei` in FDT1 would be acceptable but still not necessary in a non-dubbing translation context. The addition of yi`ge` is absolutely uncalled-for.

(7) .. someone I [^]thought I could ^{^^}trust.

.. wo`yi`wei` wo`ying`gai`
I think I should
^^xin`ren`ni`
trust you

.. yi`ge` wo`ceng` ^^xin`ren`de` ...
one MSR I once trust MOD

AP4>>

5. JACK

SA(5)>

(8) ... I .. ^{^^}know -

... Wo`^^zhi`dao` ...
I know

... Wo`^^zhi`dao` -
I know

6. JACKIE

SA(6a)>

(9) .. You ^{^^}don't know.

.. Ni`^^bu`zhi`dao` :
You not know

.. Ni`^^bu`zhi`dao` :
You not know

AP5>>

SA(6b)>

(10) ...You have ^^no idea | what I've ^been ^^through

..Ni <u>jian zhi</u> ^^^wu fa ^xiang xiang`		... Ni <u>gen ben</u> ^^bu zhi dao wo`
you simply no way imagine		you altogether don't know I
wo <u>de gan shou</u> `		<u>zen me</u> ^^guo lai de
my feelings		how been through

By using three strong word groups to emphasize what is not so intended in the original, FDt1 greatly weakens the focal information, i.e., what happened to Jackie in the past week.

SA(7)>

(11) ... I don't even think you ^^care.

.. Wo <u>shen shi</u> ren wei ni`		... Ni <u>shen zhi</u> bu ^^zai hu.
I even think you		you even not care
^^gen ben jiu bu guan xin wo`		
simply just not care about me		

This is another evidence to show that FDt1, by overlooking the function of prosodic means in foregrounding the NI, it relies on lexical and syntactic means to lay emphasis in a wordy way and on the misidentified NI at that.

Summary of SAS#1

TURN NUMBER OF		1	2	3	4	5	6	SAS#1 TOTAL
		FDs	<i>Syll.</i>	5	3	3	17	
FDt1	<i>Diff.</i>	+1	+2.5	0	+8	+1	+8.5	+21 (42.9%)
	<i>Syll.</i>	6	5.5	3	25	3	27.5	70
FDt2	<i>Diff.</i>	0	+1.5	0	+0.5	+1	+1.5	+4.5 (9.2%)
	<i>Syll.</i>	5	4.5	3	17.5	3	20.5	53.5

Table 22

Sample 2 - SAS#1:

Number of syllables in each turn and the difference between FDs and FDt

Obviously, FDt1 has departed from FDs considerably in having a far greater syllable density (with excessive syllables used **42.9%**) in this sequence, which is devastating in dubbing.

TURN		1	2	3	4				5	6		SAS Σ=	
IU		1	2	3	4	5	6	7	8	9	10	11	11
NI	<i>D</i>		X		X		X						3
	<i>M</i>												0
	<i>DM</i>	X		X							X	X	4
TOTAL		1	1	1	2				-	2		7	
%		100%	100%	100%	50%				0	66.7%		63.6%	

Table 23

Sample 2 - SAS#1:

Instances of loss of NI synchronicity with the original timing obtained in FDt1

The above table shows that in 11 intonation units as timed by FDs, FDt1 fails to deliver the NI in 7 of

them properly, either because of the dislocation or misidentification of the information focus.

SAS#2>>>

AP6>>

7. JACK

SA(8)>

(12) ... Did they give you ^anything for the ^^pain?

.. Ta men gei ni shen me
they give you what

^^ zhi tong ma?
stop pain Q

... Ta men gei ni shen men
they give you what

^^ zhi tong de ma?
pain-killer Q

8. JACKIE

SA(9a, 9b)>

(13) ... ^^Yes | but it ^^doesn't ^help.

... ^^ Gei le. ^^ Mei yong .
give ASP no use

... ^^ Gei le. | Bu guo . ^^ mei yong .
give ASP but no use

The difference between the two versions of FDT is that FDT1 is pragmatically inappropriate in sounding too abrupt and irritable.

AP7>>

SA(10)>

(14)... Your ^sister Pat had a ^^baby two days ^ago.

.. Ni de ^^ mei mei Pa di liang tian .
your sister Pat two day

qian sheng le ge ^^ hai zi .
ago give birth ASP MSR baby

... Ni ^^ mei mei Pa di sheng le
your sister Pat give birth ASP

^^ hai zi , liang tian qian .
baby two day ago

The translation of the PP two days ago in FDT1 is left-dislocated to fit in the normal TL word order resulting the change of the original NI from the mid-focus to the end-focus. FDT2 keeps the FDs word order as well as the information focus with a

desirable ring about spoken mandarin. On the other hand, the redundant words *de* in *Ni`de* and *ge`* in *sheng` le ge`* (gave birth to one...) make FDt1 sound in poor style.

9. JACK

SA(11)>

(15)... I^^heard.

.. *Wo` ^ting`shuo`le.*
I hear ASP

... *^^Ting`shuo`le.*
hear ASP

AP8>>

10. JACKIE

SA(12)>

(16) .. And ^^Ethel's due | next ^^month.

.. *^Ai`sai`er`de` yu`chan`qi`shi`*
Ethel MOD expected date be

... *^^Ai`sai`er` yu`chan`*
Ethel expect to give birth

^^xia`yi`ge`yue`
next one MSR month

| *^^xia`ge`yue`*
next MSR month

FDt1 by rigidly following the elliptical noun form of *Ethel's* in FDs, has to add *yu`chan`qi`* (expected date of the childbirth) in the translation and use the time adverbial predicatively with the linking verb *shi`*; thus has upset the information flow.

(17) .. She ^won't ^^lose her baby -

.. *ta`bu`hui`^shi`qu`^^ta`de`hai`zi.*
she not will lose ASP her baby

| ... *Ta`bu`hui`^^shi`diao`hai`zi.*
she not will lose ASP baby

The possessive pronoun *ta`de`* (her) is generally not used in such context unless for emphasis or contrast. Obviously, FDt1 means to stress on this

word instead of the focal point of this utterance,
 "to lose her baby like Jackie herself did".

11. JACK

SA(13)>

(18) .. ^^come on | ^^come on, now

.. ^^Hao^vle, hao^vle,
 All right all right

... ^^Hao^vle | ^^hao^vle hao^vle
 All right all right all right

(19)... This ^isn't some kind of ^^race.

... Zhe `you `bu shi `shen^vme ^^bi^vsai `.
 this NEG¹⁰ not be what race

...Zhe `you `bu shi `shen^vmen^^bi^vsai `.
 this NEG not be what race

Summary of SAS#2

NUMBER OF		TURN					SAS#2 TOTAL
		7	8	9	10	11	
FDs	<i>Syll.</i>	9	18	2	12	12	53
FDt1	<i>Diff.</i>	-1.5	0	+1.5	+7	-1.5	+5.5 (10.4%)
	<i>Syll.</i>	7.5	18	3.5	19	10.5	58.5
FDt2	<i>Diff.</i>	-1	0	+0.5	+2.5	0	+2 (3.7%)
	<i>Syll.</i>	8	18	2.5	14.5	12	55

Table 24

Sample 2 - SAS#2:
 Number of syllables in each turn and the difference between FDs and FDt

Although in Table 24 the difference in syllable count between FDs and FDt1 is not so striking, the additional syllables used in FDt1 to the original length is nearly three times as many as those in FDt2. This is still significant for such a relatively short sequence in revealing FDt1's problem of verbosity in dubbing.

TURN		7	8		9	10		11	SAS Σ=	
IU		12	13	14	15	16	17	18	19	8
NI	D			X						1
	M						X			1
	DM					X				1
TOTAL		-	1		-	2		-		3
%		0	50%		0	100%		0		37.5%

Table 25

Sample 2 - SAS#2:

Instances of loss of NI synchronicity with the original timing obtained in FDT1

It is not negligible that three different types of loss of NI are found in FDT1 out of this short sequence of 8 IUs.

SAS#3>>>

AP9>>

12. JACKIE

SA(14a)>

(20) ... It's what ^{^^}Kennedy [^]wives | are ^{^^}expected to do

... Zuo wei ^{^^}Ken ni di jia ⁻ de qi zi,
as Kennedy family MOD wife

... Zhe jiu shi ^{^^}Ken ni di jia ⁻
this just F Kennedy family

[^]qi zi | ^{^^}yao zuo de:
wife must do T

(21) ... Make ^{^^}babies.

.. jiu shi yao ni ji sheng ⁻ ^{^^}hai zi
just be want you not only make baby

... Sheng ⁻ ^{^^}hai zi,
make baby

FDT1 has upset the FDTs rhythm by sticking to the TL grammar with no regard to the lip-sync effect for a series of mismatched information segments in this turn, as will be further seen through to the IU (25).

(22) ... make ^^politics

.. you yao` ^^can zheng` ...
but also must partake in politics

... mang` ^^can zheng`
busy partake in politics

(23)... and turn the ^^other way

.. dang`ni`de` zhang fu xing wei`
when your husband behaviour

... hai`yao` ^^shi`er`bu`jian`
also must turn a blind eye to

^^you`shi`jian`dian`shi`,
not so discreet ←

FDt1 has brought forward the time adverbial **when** ... to the beginning of the main clause in dealing with the translation obstacle to keeping the original word order and sounding naturally Chinese at the same time, but only to permute the original information presentation in so doing.

(24) .. when it comes to their ^husband's ^^indiscretions

.. hai`yao` ^^zhuang`chu`ling`
also must pretend ASP another
yi`ge` yang`zi`.
one MSR look

... ta`men` zhang fu de`
their husband
^^xing`wei`bu`jian`
indiscretion

By contrast, FDt2 has successfully solved this problem by changing the sentence pattern to get around the adverbial clause tangle while keeping the timing of the original information unchanged.

SA(14b)>

(25) ... Guess I've ^^failed | at ^all ^^three

.. ^^San`ge` fang`mian`wo`dou`
three MSR respect I all
shi`bai`le`.
fail ASP

... Wo` ^^kui`dui` | zhe`
I ashamed to face these
^^san`fang`mian`
three respects

Again, FDt1 is unable to keep the PP in the postposed position and has to sacrifice the FDs

structure to fit in the standard Chinese grammar. FDt2 on the other hand has tactically retained the original position of the message convey by the PP by making the verb transitive.

AP10>>

13. JACK

SA(15)>

(26).. What do you ^^mean?

.. Ni ~ ^^zhe shi <u>shen me</u> yi `si?		... <u>Shen me</u> ^^yi `si?
you this be what meaning		what meaning

Pragmatically, FDt1 doesn't faithfully convey Jack's timid response to Jackie's hint about his indiscreet behaviour, which shouldn't have been so pointed and stern in tone as the translation appears to be. In fact, Jack's question is focused on the propositional meaning rather than the illocutionary meaning of Jackie's remark.

14. JACKIE

SA(16a)>

(27) ... You ^^forget

.. Ni ~ ^^wang `le...		... Ni ~ ^^ wang `le,
you forget ASP		you forget ASP

(28) ... I grew up with one of the ^greatest ^^philanderers | of ^all ^time

.. wo yi zhi `he `yi `ge `ai `qing `bu `		...wo shi `cong `xiao `jiu `kan `zhe yi `ge `
I all along with one MSR love not		I F since child watch ASP one MSR
^^zhuān `yi `de ren `yi `qi `sheng `huo `.		^^qing `chang `gao `shou `zhang `da `de.
faithful MOD person together live		debauchee grow up T

The "philanderer" refers to Jackie's father Bouvier; plus all the modifiers to this word, it is similar to the Chinese phrase qing chang gao shou

(a womanizer) in concept and style. FDT1's ambiguity exposes the uncertainty in recognizing this fact and mis-directs the focus of information of this segment.

SA(16b)>

(29)... I know ^{^^}exactly | ^{^^}how it's [^]done, Jack

Suo yi wo fei chang liao jie
so I very much know

zhe jian shi, Jie ke.
this MSR affair Jack

Tai qing chu shi zen me hui
too clear about be what sort

shir le, Jie ke.
affair ASP Jack

Because of the confused logic in the previous translation, suo yi (therefore) is used in FDT1 in an attempt to smear some cohesion between the two segments to make sense of their relevance to each other. However, zhe jian shi (this affair) specifies the subject of Jackie's knowledge as not being such cheating business in general but what Jack did this time behind her back., and thus eventually misleads the audience.

Summary of SAS#3

As can be seen in the tally below, FDT1 has used 16.2% more syllables than the original; whereas FDT2, being very close to the original in segment length once again, has used 4.7% less the overall number of syllables in FDs.

TURN NUMBER OF		12	13	14	SAS#3 TOTAL
		FDs	Syll.	42	
FDt1	Diff.	+5.5	+3	+3.5	+12 (16.2%)
	Syll.	47.5	7	31.5	86
FDt2	Diff.	-3.5	0	0	-3.5 (4.7%)
	Syll.	38.5	4	28	70.5

Table 26

Sample 2 - SAS#3:
Number of syllables in each turn and the difference between FDs and FDt

TURN		12					13	14			SAS Σ=	
IU		20	21	22	23	24	25	26	27	28	29	10
NI	D		X		X	X	X					4
	M									X		1
	DM							X			X	2
TOTAL		4					1	2			7	
%		66.7%					100%	66.7%			70%	

Table 27

Sample 2 - SAS#3:
Instances of loss of NI synchronicity with the original timing obtained in FDt1

Here again is the familiar situation in that FDt1 contains a high percentage of NI dislocation and misplacement in a sequence of the average length (Cf. Table 17).

SAS#4>>>

AP11>>

15. JACK

SA(17)>

(30) ... Maybe I should start spending ^{^^}more [^]time | at ^{^^}home ..

.. Wo ^ˇyi ^ˊhou ^ˋduo ^ˋhua ^ˋdianr ^ˇ
I from now on more spend a little

shi ^ˊjian ^ˋzai ^ˋjia ^ˋli.
time PreP home LOC

... Ye ^ˇxu ^ˇwo ^ˋying ^ˋgai ^ˋduo ^ˋdai ^ˋ
Maybe I should more stay

zai ^ˋjia ^ˋli ^ˇle.
PreP home LOC ASP

The dislocation of the NI here in FDt1 should have been avoided if less freedom and more regard for dubbing as a special translation were given in the translating process.

16. JACK

SA(18)>

(31) ... We ^{^^}don't [^]have a home

.. Wo ^ˇmen ^{^^}mei ^ˊyou ^ˋjia ^ˋ.
we not have home

... Wo ^ˇmen ^{^^}mei ^ˊyou ^ˋjia ^ˋ.
we not have home

AP12>>

SA(19)>

(32) .. I want to live with my ^{^^}mother in [^]Newport

.. Wo ^ˇyao ^ˋqu ^ˋNiu ^ˋbo ^ˋte ^ˋgen ^ˋwo ^ˇ
I want go Newport with my

mu ^ˋqin ^ˋzhu ^ˋle.
mother live ASP

... Wo ^ˇyao ^ˋgen ^ˋwo ^ˋmu ^ˋqin ^ˋzhu ^ˋ
I want with my mother live

zai ^ˋNiu ^ˋbo ^ˋte ^ˋ.
PreP Newport

FDt2 sounds perfectly spoken Mandarin even though the translation of the PP **in Newport** stays in the original position. FDt1, without heeding the dubbing requirement for the NI timing, unhesitatingly uses the regular translating strategy of left-dislocating the PP and upsets the whole information structure at the same time.

17. JACK

SA(20a)>

(33) ... ^{^^}Wait a minute

.. Wei , ni ~ ^^ <u>deng yi deng</u> ~ hay you wait a while		... ^^ <u>Man zhe, man zhe.</u> slowly (hold on)
--	--	---

(34) .. ^^Wait a minute

.. ^^ <u>deng yi deng</u> ~ wait a while		... ^^ <u>man zhe</u> .. hold on
---	--	-------------------------------------

SA(20b)>

(35) .. I ^just got off a ^^plane

.. Wo ~ ^^ <u>gang xia fei ji</u> ~ I just off plane		... Wo ~ ^yi xia ~ ^^ <u>fei ji</u> ~ I just off plane
---	--	---

(36) ... I've ^lost my ^^daughter

.. Wo ~ yi jing ~ <u>shi qu</u> le ^^ <u>nu er</u> ^ I already lose ASP daughter		... Wo ~ yi jing ~ ^mei le ^^ <u>nu er</u> ^ I already lose ASP daughter
---	--	---

(37) ... ^^You ^too .. you know

.. ^^Ni ~ ye ~ <u>shi qu</u> le ta ^ you too lose ASP her		... ^^Ni ~ ye ~ <u>shi</u> , <u>shi ba</u> ... you too isn't it
--	--	--

FDt1 fails to achieve the equivalent effect for this segment in both semantic and stylistic dimensions

AP13>>

(38) ... ^Now ^^suddenly

.. wo ~ you ~ yao ~ <u>shi qu</u> wo ~ de ^^ <u>qi zi</u> . I also have to lose my wife		... <u>xian zai</u> ~ ^^ <u>tu ran jian</u> ; now suddenly
--	--	---

The misplacement of the whole IU in FDt1 for this time-slot is unforgivable, because it is clearly caused by the translator's unrestrained liberty of re-ordering information units after the style that is presumably considered more Chinese. Besides, **wo de** (my) in this translation should be left out if the effort here is not to make it sound un-Chinese. The next FDt1 segment is a translation for this FDS IU.

(39) .. I'm losing my ^^wife

.. <u>Zhe</u> <u>dui</u> <u>wo</u> <u>lai</u> <u>shuo</u> <u>tai</u> <u>iu</u> <u>ran</u> <u>le</u> !		... <u>Wo</u> <u>you</u> <u>yao</u> <u>shi</u> <u>qu</u> <u>qi</u> <u>zi</u>
this to me too sudden ASP		I also will lose wife

FDt1 here is meant to be a round-up remark on what has been said in the previous segments only to misdirect the original flow of information. The translation by itself is wordy and not faithful.

18. JACKIE

SA(21)>

(40) ... ^^Not so sudden .. Jack

.. <u>Yi</u> <u>dian</u> <u>r</u> <u>ye</u> <u>bu</u> <u>iu</u> <u>ran</u> , <u>Jie</u> <u>ke</u> <u>Bing</u> <u>bu</u> <u>tu</u> <u>ran</u> , <u>Jie</u> <u>ke</u> .
not a bit sudden Jack		not so sudden Jack

API4>>

SA(22)>

(41) .. It actually took ^^five ^days

.. <u>Shi</u> <u>shi</u> <u>shang</u> <u>wo</u> <u>yi</u> <u>jing</u> <u>hua</u> <u>le</u>		... <u>Qi</u> <u>shi</u> <u>yi</u> <u>jing</u> <u>wu</u> <u>tian</u> <u>le</u> .
in fact I already spend ASP		actually already five day ASP
<u>wu</u> <u>tian</u> <u>shi</u> <u>jian</u> .		
five day time		

FDt1 unnecessarily puts emphasis on the first half of the segment only to make it sound too formal and unfit for the sociolinguistic context.

(42) ... ^Five= ^days= of lying here ^^alone

.. <u>Zhe</u> <u>shi</u> <u>wo</u> <u>yi</u> <u>sheng</u> <u>zhong</u> <u>zui</u>		... <u>Wu</u> <u>tian</u> <u>jiu</u> <u>tang</u> <u>zai</u> <u>zher</u> , <u>wo</u>
this be my in life most		five day just lie PreP here me
<u>di</u> <u>luo</u> <u>de</u> <u>wu</u> <u>tian</u> ,		<u>yi</u> <u>ge</u> <u>ren</u> .
low MOD five day		one person

On the left column, the translation of this IU is preempted by the translation of the next IU. The reason for this change of the IU order is due to the syntactic constraint caused by the PP **during the**

lowest time of my life in the next IU that leaves little alternative for the translator but to restructure the whole sentence. Unable or unmotivated to keep it in the original position, FDt1 reverses the order between the main clause and the PP as a legitimate translation move to deal with such problem stemming from the interlingual difference, while ignoring its devastating side-effect on dubbing. The shift of the information focus is also due to fact that this translation has used the unnecessary emphatic construction *zhe`shi`... zui`... de* (it is the most ... of ...) instead of the a simple time adverbial for the PP. FDT2 is faithful to the original in having achieved the Type 2 match effect. The lengthening of the two syllables in FDs leaves just enough room for FDT2's two additional words without missing the exact timing.

(43) ... during the ^^lowest time of my ^life

<p>.. wo <u>dan`du</u> `^^yi`ge`ren`tang`zai` I alone one person lie PreP</p> <p><u>zhe`li</u>, here</p>	<p>... Yi`sheng`zhong`^^zui`di`luo` during the whole life most low</p> <p>de`re`zi MOD days</p>
--	---

By FDt1's rendering in an re-shuffled word order, this stretch of utterance sounds increasingly constructed and undesriably poetic as it reaches to the end of the turn.

(44) .. ^^desperately needing my ^husband | to be ^^with me

.. ^^ <u>fei</u> <u>chang</u> <u>xu</u> <u>yao</u> <u>wo</u> <u>de</u> <u>zhang</u> <u>fu</u>		... ^^ <u>fei</u> <u>chang</u> <u>fei</u> <u>chang</u> <u>xu</u> <u>yao</u>
very much need my husband		desperately need
<u>he</u> <u>wo</u> <u>zai</u> <u>yi</u> <u>qi</u> ...		<u>zhang</u> <u>fu</u> <u>zai</u> <u>wo</u> <u>shen</u> <u>bian</u>
with me together		husband PreP my side

Two points are worth mentioning with regard to the translations of this segment: a) **fei** **chang** needs to double up to match the intensity carried by **desperately**; and b) by following the English usage rigidly, FDT1 has used the needless **wo** **de** to modify **zhang** **fu**, which makes the translation even more in lack of the naturalness of spoken language.

(45) ... and ^^finally realizing

.. <u>zui</u> <u>hou</u> <u>wo</u> ^^ <u>zhong</u> <u>yu</u> <u>yi</u> <u>shi</u> <u>dao</u> <u>zui</u> <u>hou</u> ^^ <u>zhong</u> <u>yu</u> <u>ming</u> <u>bai</u> <u>le</u> ..
at last I finally realize ASP		at last finally clear ASP

(46) he ^^never ^will be.

.. ^^ <u>yong</u> <u>yuan</u> <u>ye</u> <u>bu</u> <u>hui</u> <u>le</u> <u>ta</u> ^^ <u>gen</u> <u>ben</u> <u>bu</u> <u>hui</u>
for ever NEG not will ASP		he absolutely not will

Apart from being an unnecessarily longer translation than FDT2, FDT1 has changed the tone of the original from the one that conveys some bitterness in the convinced realization to one that greatly weakens the miserable feelings suggested by the original utterance.

Summary of SAS#4

NUMBER OF		TURN				SAS#4 TOTAL
		15	16	17	18	
FDs	Syll.	11	16	34	54	115
FDt1	Diff.	0	0	+9	+13.5	+22.5 (19.6%)
	Syll.	11	16	43	67.5	137.5
FDt2	Diff.	-0.5	-0.5	-0.5	+1	-0.5 (0.4%)
	Syll.	10.5	15.5	33.5	55	114.5

Table 28

Sample 2 - SAS#4:

Number of syllables in each turn and the difference between FDs and FDt

The figures shown in the above table are self-explanatory. Without doubt, FDt1 is intolerably wordy with as many as 19.6% extra syllables used, which is certainly unacceptable in the dubbing context. FDt2 maintains the similar length of each segment to FDs as a basic feature of its formal correspondence to the original. The syllable count between FDt2 and FDs in the whole sequence is convincingly close.

TURN	15	16	17						18						SAS Σ=			
IU	30	31	32	33	34	35	36	37	38	39	40	41	42	43	44	45	46	17
NI	D	X							X			X	X					4
	M																	0
	DM		X			X				X				X				4
TOTAL	1	1	3						3						8			
%	100%	50%	42.9%						42.9%						47.1%			

Table 29

Sample 2 - SAS#4:

Instances of loss of NI synchronicity with the original timing obtained in FDt1

Misplacement of the information focus on a wrong lexical item usually takes place with its appearance in a different position from the original one in an IU. That explains why instances of *M* alone are not frequently found. Dislocation of the NI is the widespread phenomenon throughout FDt1. In this sequence there are equal numbers of *D* and *DM* which together happen to nearly half of all the IUs. As will be seen in the summary of Sample 2, the severity of this problem is consistent with the findings in the previous sample.

5.3.3 Discussion of the Results

On the average, our analysis of Sample 2 so far has yielded very similar results at the SAS level to those found in Sample 1. With respect to the syllable count and the NI loss in FDt1, the following tabulated summary offers a full view of the major facts from each SAS as well as the resultant statistics of the whole dialogue in this scene.

<i>Jackie Sc. 2-1.13</i>		SAS#1	SAS#2	SAS#3	SAS#4	TOTAL
# of	FDs	49	53	74	115	291
Syll.	FDt1/FDt2	70/53.5	58.5/55	86/70.5	137.5/114.5	352/293.5
Difference		21/4.5	5.5/2	12/-3.5	22.5/-0.5	61/2.5
Difference (%)		42.9/9.2	10.4/3.7	16.2/-4.7	19.6/-0.4	<u>21/0.9</u>
Total # of IUs		11	8	10	17	46
NI loss in FDt1		7	3	7	8	25
NI loss (%)		63.6	37.5	70	47.1	<u>54.3</u>

Table 30

Sample 2: Differences in syllables used between FDs and FDt and NI failure in FDt1

Table 30 shows that FDt1 has used 21% more syllables than FDs in this dialogue scene whereas the difference in number of syllable used by FDt2 from that of FDs is insignificant (less than 1%). On the other hand, the loss of the information focus in FDt1 is still heavy – more than half of the information segments (54.3%) fail to deliver the New Information in a faithful manner in keeping with the original intention and timing.

From another point of view, the tendency to use more words than appropriate in rendering each segment of FDs into FDt1 can be confirmed by the similar findings in terms of the percentage range of excessive syllables used in this sample to those in the last sample (42.9% ↔ 10.4% as compared with 32.4% ↔ 11.9%). By the same token, the consistent status of FDt2 in approximating the same number of

syllables used by FDs can also be evidenced by such an observation (9.2% ↔ - 4.7% as compared with 6% ↔ - 6.1%), which can be more clearly perceived from Figure 23 (as compared with Figure 22).

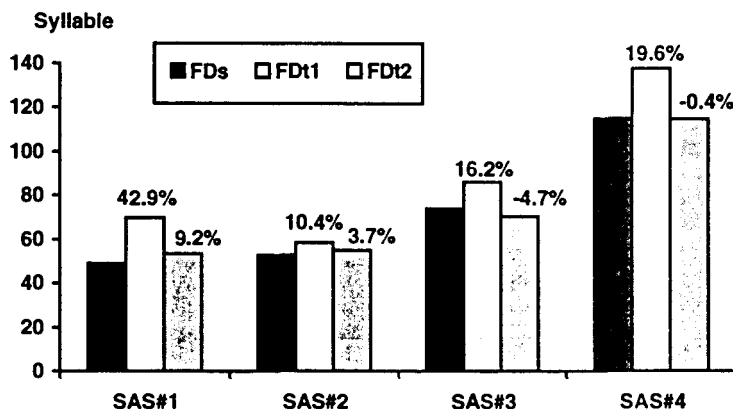

Figure 23

Sample 2: Syllable count by speech act sequence and discrepancies in percentage between FDs and FDT

The distribution of the NI dislocation types in this sample is found as follows.

SAS	DISLOCATION TYPE				D (incl. DM) Total	M (excl. DM)	TOTAL
	Motivated		Constrained				
	PS	MS	SC	ID			
1	3	1	1	2	7	0	7
2	1	-	1	-	2	1	3
3	3	-	3	-	6	1	7
4	3	2	3	-	8	0	8
TOTAL	10/23	3/23	8/23	2/23	23/25	2/25	25/46
%	43.5%	13%	34.8%	8.7%	92%	8%	54.3%

N = 46

Table 31

Sample 2: Causes of NI dislocation and their relative frequency in FDT1

As indicated here, in this sample PS and SC are also the two major factors that contribute to the motivated and constrained types of causes to

account for the NI dislocation respectively. Compared with Sample 1, the frequencies of occurrence of them in all the instances of NI dislocation in the entire sample are fairly close, albeit the other way round: 56.5% and 43.5% versus 48% and 52%. The percentage of the dislocation, as distinguished from misplacement, of the NI in all the instances of the NI loss in this sample is 92%, which is a re-occurrence of the situation in sample 1 where the figure is 91%.

The error rate in FDt1 is also higher in this selection with 36.9% of all the 46 information segments being mistranslated by the linguistic, stylistic or pragmatic criteria.

N = 46

SAS	Linguistic	IU	Stylistic	IU	Pragmatic	IU	TOTAL		
							W	P	M
1	-		2P	(7, 10)	2P	(3, 11)	-	4	-
2	-		-		1P	(12)	-	1	-
3	2P, 1W	(24,28,29)	1P	(23)	1P	(26)	1	4	-
4	1M	(37)	1P,2W	(45,33,39)	2P,1M	(41,42,46)	2	3	2
Σ	4 (23.5%)		6 (35.3%)		7(41.2%)		17 (36.9%)		

Table 32

Sample 2: Types of mistranslation in FDt1

As Table 32 indicates, problems related to the pragmatic function of the translation are more numerous (41.2%) than those in the other two dimensions, although each of them occurs frequently enough (23.5% and 35.3% respectively).

5.4 Sample 3: *Mutuality*

The third sample for scrutiny, like the previous two, is randomly selected from our experiment with the FITNIAST model on the mini-series. It is a dialogue from *Scene 2, Act 2, Part 3* of *Jackie* between Jackie and Bobby (i.e., Robert Kennedy, Jack's brother). For the sake of simplicity, the analytical process in this section will be presented only in a short form, focusing on the results.

5.4.1 Analysis of the Source Text

This dialogue takes place not long after JFK's assassination, in front of the first house owned by Jack and Jackie, now home of the Robert Kennedy family. The scene is set in an atmosphere of melancholy, which is brightened up by some communion of morale-boosting towards the end. Overall it conveys a reciprocity of sentiments, hence the theme title ***Mutuality***. The general tone is depressive, mood-sharing, supporting and suggestively intimate.

Arrived at the comprehensive breakdown of FDs after going through the analytical process, Table 33 shows the eventual result of a series of steps

taken from examining the dialogue in both the informational and interactional dimensions.

Jackie Sc.3-2.2

Scene: Mutuality

Tone: depressive, encouragement-finding

TURN	SPEECH ACT FUNCTION	IU	CODED TRANSCRIPT OF THE DIALOGUE	Adjac. Pair STATUS	SAS TOPIC
1. BOBBY	(1) Offer →	1	... I'm ^^glad you ^came today.	API: AAP/UAP	SAS#1 Topic: Jackie's melancholic mood
(BOBBY)	(2) Statement	2	... I know how ^^hard it is for you.	AP2:	
2. JACKIE	(3) Acknowledge.	3	.. And ^^you.	AAP/ TAP	
(JACKIE)	(4) Statement	4	... All the ^bright light has ^^gone from the world.	AP3:	Function: Setting the scene
3. BOBBY	(5) Command	5	... ^^Jackie –	AAP/UAP	
4. JACKIE	(6a) Statement	6	... I ^^try ...	AP4: CAP/TAP	
		7	.. I ^^do ...		
		8	... I ^^try ...		
		9	... Just like ^^you were ^trying out there in the field		
(6b) Statement →	10	.. And maybe it ^seems like ^^playing the game			
	11	... But it has ^no ^^meaning.			
5. BOBBY	(7) Statement	12	... I'm thinking about ^^leaving the ^Administration	AP5: AAP/UAP	SAS#2 Topic: Bobby's predicament Function: Focusing on the main problem
6. JACKIE	(8) Question	13	... ^^What?	AP6: CAP/TAP	
(JACKIE)	(8) Question	13	... ^^What?		
7. BOBBY	(9) Answer	14	... I'm ^no good to ^^anybody.		
		15	... ^^Can't ^eat.		
		16	... Can't ^^sleep		
		17	... Can't ^^work.		
		18	... Go to the ^Capitol every ^^day...		
		19	... ^^Memories...		
(BOBBY)	(9) Statement	14	AP7:	
19		... ^^Memories...			
8. JACKIE	(10) Acknowledge.	20	... I ^^know.	CAP/TAP	
9. BOBBY	(11) Statement →	21	... ^^Johnson and his clone's trying to ^credit l of what ^^Jack did	AP8:	AAP/UAP
		22	... and I ^don't want to ^^stick around l to ^^see that happen		
		23	... Besides, Lyndon can't ^stand ^^me l nor I ^^him		
10. JACKIE	(12) Command	24	... Don't ^^quit on us, Bobby.	AP9:	SAS#3 Topic: Jackie's effort to encourage Bobby and herself
11. BOBBY	(13) Contradiction	25	... I ^didn't ^^say l was quitting –	CAP/UAP	
12. JACKIE	(14a) Statement	26	... You're giving ^^up,	API0:	
		27	.. I can ^^feel it	CAP/TAP	
	(14b) Command	28	... But you and I can't ^^afford to do that,		
		29	... because of the ^^children		
	(14c) Statement	30	... John-John needs a ^strong ^^father		

			figure ...		
13. BOBBY	(15a) Undertaking	31	... I'll [^] be there for [^] John-John.		<i>Function:</i>
	(15b) Statement	32	... I'm just not [^] sure about the ^{^^} rest right now		
14. JACKIE	(16) Statement →	33	... You know [^] Jack would have [^] wanted us to ^{^^} carry on	AP11:	Confirming the solution
		34	.. ^{^^} Me through the ^{^^} children	AAP/UAP	
		35	... ^{^^} you through continuing to ^{^^} serve		
15. BOBBY	(17) Question	36	... You know what Jack would have ^{^^} said...	AP12:	SAS#4
16. JACKIE	(18) Question	37	... ^{^^} What would he have said?	AAP/UAP	<i>Topic:</i>
(JACKIE)	(18) Question	37	... ^{^^} What would he have said?	AP13:	Comforting closeness
17. BOBBY	(19) Answer	38	.. Something ^{^^} unprintable.	CAP _p /TAP	
18. JACKIE	(20) Question	39	... Will you ^{^^} think about it?	AP14:	
19. BOBBY	(21) Answer	40	... ^{^^} Sure.	CAP _p /TAP	<i>Function:</i>
(BOBBY)	(22) Statement	41	... I ^{^^} love you, kid.	AP15:	A cheering ending
20. JACKIE	(23) Statement	42	... I love ^{^^} you, too.	AAP/TAP	

Table 33

Structural breakdown of the Scene *Mutuality* and the contextual relations between its components from both informational and interactional perspectives

A remarkably different feature of this dialogue from the previous two is that there is little tension in the interaction and the tempo is slow and easygoing. This significant point for effective translation can be informed by the fact that: (a) more than half of the adjacency pairs that constitute the dialogue are of the AAP type (53.3%); (b) for both parties, there are frequent undisturbed long turns that contain in each of them more than one speech act or, a speech act consisting of a string of intonation units; and (c) the same general topic keeps its flow cohesively with each adjacency pair in spite of the high percentage of the preceding UAPs (46.7%).

These and other conclusions drawn from the analytical phase have provided a sound basis for the evaluation of the translations next.

5.4.2 Comparison and Evaluation

In this part of the sample study, only part of those instances of translation problems in FDT1 are selected for discussion that, while representing the most likely solutions to the typical English-to-Chinese translation 'posers', have been drastically remedied to suit the dubbing demands with satisfactory effect by using the FITNIATS approach. These examples are marked with the turn number and the IU number only. The SAS summaries are left out, but the key statistics can also be found in the end-of-scene summary in 5.4.3

1. BOBBY

(1) ... I'm ^{^^}glad you [^]came today.

.. Ni jīn tiān néng ^ˊlái ^ˊwǒ hěn ~
 you today can come I very

^{^^}gāo xìng ˋ .
 glad

... ^{^^}Tai hào ˋle ni ^ˋlái ^ˊle
 so good ASP you come ASP

FDT1 is no doubt idiomatic Chinese, but a better alternative is not impossible. FDT2, in keeping the FDs word order, remains to be natural and faithful in spirit. It has the appropriate degree

of formality for the context and, more importantly, is dubbing-friendly.

(2) ... I know how **hard** it is for you.

<p>.. <u>Wo</u> <u>hen</u> <u>li</u> <u>jie</u> <u>ni</u> <u>de</u> <u>xin</u> <u>qing</u> . I very understand your feelings</p>	<p>... <u>Zhi</u> <u>dao</u> <u>duo</u> <u>bu</u> <u>rong</u> <u>yi</u> <u>zhe</u> <u>dui</u> <u>ni</u> . know how hard this for you</p>
---	---

The translation of this utterance into Chinese is another translator's headache if free translation is not called for, since a direct translation for the PP **for you** is customarily not put after the verbal phrase in Chinese. FDt1 chooses to interpret the meaning in the TL manner but has thus departed from the original in form and function. To overcome this problem, FDt2 renders FDs in an equally colloquial style, using an add-on phrase **zhe dui ni** (it is for you) to finish an SL-oriented structure with, which is as well in keeping with spoken Chinese grammar.

2. JACKIE

(3) ... And **you**.

<p>... <u>Ni</u> <u>ne</u> ? and you?</p>	<p>... <u>Ni</u> <u>ye</u> <u>shi</u> . you too be</p>
--	---

FDt1 is totally out of context. It is a gross mistake that FDt1 has betrayed the original by treating IU(3) as a question and breaking the coherence between this utterance and IU(2).

7. BOBBY

(14) ... I'm ^no good to ^^anybody.

..Wo ʔdui ʔʔshei ʔdou ʔmei ʔyou ʔhao ʔchu ʔ. | ..Wo ʔwu ʔzhu ʔyu ʔʔren ʔhe ʔren ʔ.
I to anybody all no good | I no help to anybody

FDt1 has adapted the original into a similar Chinese expression, but dislocated the information focus in so doing. By drawing on the rich resources of expression and the flexible usage of colloquialism in Chinese, FDt2, has got over the obstacle created by the PP to anybody and achieved the FITness effect.

12. JACKIE

(26) ... You're giving ^^up,

... Dan ʔwo ʔʔgan ʔjue ʔdao ʔ | ... Ni ʔzai ʔʔfang ʔqi ʔ.
but I feel ASP | you ASP give up

IUs (26-27) are rendered in the reverse order in FDt1, presumably for the purpose of sounding 'more Chinese'. As a matter of fact, such luxury is taboo in translating for dubbing for the simple reason that the words must match the picture, even though the process of the articulation takes only 1.77 seconds. The accumulative effect of the audio-visual gap is disastrous, because a film is a continuing human experience of intensive synthesized reception. This fact can be counter-evidenced by the distinctive effect created by FDt2, which in this case does not sound less natural by retaining the FDs word order.

(27)... I can feel it.

<p>... ni ˊ zai ˋ ˋˋfang qi ˋ : you ASP give up</p>	<p>... wo ˋ neng ˋ ˋˋgan dao ˋ : I can feel ASP</p>
--	--

The next 3 IUs reveal two instances of undesirable TL-oriented translation in FDt1, but instead of being the motivated inversion, they are the result of adopting poor solutions to the translatability problem caused by the syntactic constraint. In IUs (28-29), it is the PP **because of the children**, and in IU (31), it is the PP **for John-John**, that seem to leave the translator of FDt1 little choice but transposing the PPs from the original position. Twice again, FDt2 has successfully overcome this stumper and arrived at Type 2 match in both cases.

(28) ... But you and I can't afford to do that

<p>... <u>Wei le hai zimen</u>, for children</p>	<p>... Ke ni ˋ he wo ˋ ˋˋbu neng zhen me zuo ˋ But you and I can not like this do</p>
---	---

(29) ... because of the children

<p>... wo he ni ˋ dou ˋ ˋˋbu neng fang qi ˋ : I and you neither can't give up</p>	<p>... yin wei ˋ you ˋ ˋˋhai zi men. because there be children</p>
--	---

13. BOBBY

(31) ... I'll be there for John-John.

<p>.. <u>Wei le xiao Yue han</u> wo hui liu ˋ for little John I will stay zai nar ˋ PreP there</p>	<p>... Wo hui liu ˋ zai nar wei xiao ˋ I will stay PreP there for little <u>Yue han</u> John</p>
---	---

From the comparative analysis throughout this scene, it re-confirms our initial conclusion that

FDt1 bristles with fatal problems for dubbing in both form and function. The same problems with similar severity are detected in FDt1 in this dialogue compared with the previous two samples, the evidence of which will be detailed in the summary of Sample 1 below.

5.4.3 Discussion of the Results

The analysis of this final sample has also exposed the severity of the two major related problems of FDt1, viz., the oversized lexical representation and the misrepresented information structure of the original dialogue. The upper and lower parts of Table 34 indicate respectively that, in this selection, FDt1 has used 20.6% more syllables of the FDs total and that 52.4% of the translation segments which are timed to fit in the original designated slots for the spoken words to match the visual have failed to deliver the flow of information appropriately.

<i>Jackie Sc. 3-2.2</i>		SAS#1	SAS#2	SAS#3	SAS#4	TOTAL
# of	FDs	60	81	88	33	262
Syll.	FDt1/FDt2	82/62.5	91/79	103.5/91.5	39.5/33.5	316/266.5
Difference		22/2.5	10/-2	15.5/3.5	6.5/0.5	54/4.5
Difference (%)		36.7/4.2	12.3/-2.5	17.6/3.9	19.7/1.5	<u>20.6/1.7</u>
Total # of IUs		11	12	12	7	42
NI loss in FDt1		6	5	9	2	22
NI loss (%)		54.5	41.7	75	28.6	<u>52.4</u>

Table 34

Sample 3: Differences in syllables used between FDs and FDt and NI failure in FDt1

These two problems are further addressed as follows. Figure 24 shows graphically the difference in syllabic density between FDt1 and FDt2 benchmarked against that of the original. The two ends of the difference range for FDt1 spans 36.7% ↔ 12.3%, whereas for FDt2 it is still as low as 4.2% ↔ -2.5%.

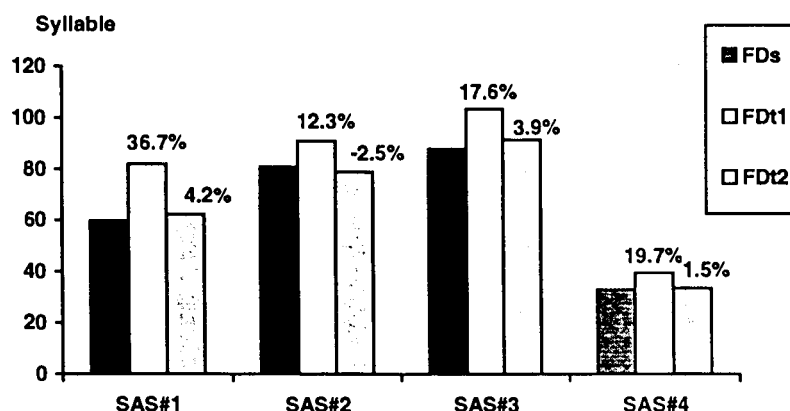

Figure 24

Sample 3: Syllable count by speech act sequence and discrepancies in percentage between FDs and FDt

Table 35 tallies the instances of different dislocation or loss of the information focus in each speech act sequence, as well as the total number and occurrence frequency of such loss in the entire dialogue scene.

SAS	DISLOCATION TYPE				D (incl. DM)	M (excl. DM)	TOTAL
	Motivated		Constrained				
	PS	MS	SC	ID	Total		
1	2	1	3	-	6	0	6
2	1	-	2	1	4	1	5
3	3	-	5	-	8	1	9
4	-	-	1	1	2	0	2
TOTAL	6/20	1/20	11/20	2/20	20/22	2/22	22/42
%	30%	5%	55%	10%	90.9%	9%	52.4%

N = 42

Table 35
Sample 3: Causes of NI dislocation and their relative frequency in FDt1

As it shows, **90.9%** out of the 22 instances of misrepresented information structure are caused by dislocation of the NI in each segment, either initiated by the translator in pursuit of a certain style (**35%**) or compelled by the linguistic/cross-cultural constraints to re-structure in conformity with the standard TL grammar (**65%**).

The last evidence of FDt1's problematic quality from the analysis of this sample is regarding the condition of the quantity and types of mistranslation in FDt1, which are summarized in Table 36 below.

SAS	Linguistic	IU	Stylistic	IU	Pragmatic	IU	TOTAL		
							W	P	M
1	-		1P	(4)	2P, 1W	(2,3,10)	1	3	-
2	1W	(12)	-		1P	(19)	1	1	-
3	2W	(24,25)	1P	(35)	1W	(32)	3	1	-
4	1W	(38)	-		1M	(41)	1	-	1
Σ	4 (33.3%)		2 (16.7%)		6 (50%)		12 (28.6%)		

Table 36

Sample 3: Types of mistranslation in FDt1

As in the previous samples, the error rate is around 30% of all the segments for translation, and the mistakes of the *pragmatic* category also pose the most outstanding problem (50%).

5.5 General Discussion of the Results

From the analysis of the three samples above, findings can now be compared and general comments be made with respect to the translation quality of FDt1 and FDt2 in the perspective of the whole teleplay. We will first examine the key statistics from the three end-of-the-scene discussions tout ensemble, which will stand as the key evidence of the disparate TQ standards of FDt1 versus FDt2, even though this study is not meant to be a quantitative one. Then we will arrive at the final evaluative statement on the TQ of the two translations based on these findings in substantiating and validating the assumption from

our implementation of the FITNIATS model on FDT1 and FDT2 throughout the process of our case study of Jackie in its entirety.

First, strikingly similar results of the syllable count in percentage ratio are found in the three dialogues despite the difference in sample size.

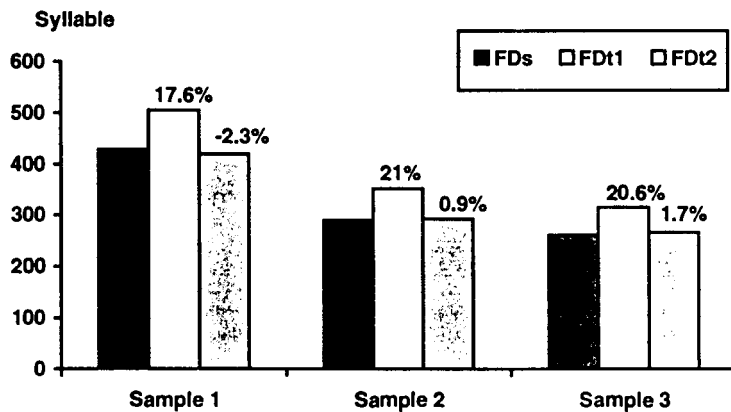

Figure 25
Syllable count by samples and discrepancies in percentage between FDs and FDT

As Figure 25 shows, FDT1 outgrows FDs in number of syllables contained by around 20% in all the three cases. By contrast, FDT2 consistently approximates the original length with a difference of only less than 2.5%. In the context of translating for FD dubbing, it is essential to attain the goal of formal correspondence to the SLT, the syllabic density of which must be taken as a threshold template to meet. FDT1's verbosity is an inevitable outcome of the erroneous approach to FDT and, in turn, it frequently causes total confusion of the

original information structure, as indicated in Figure 26.

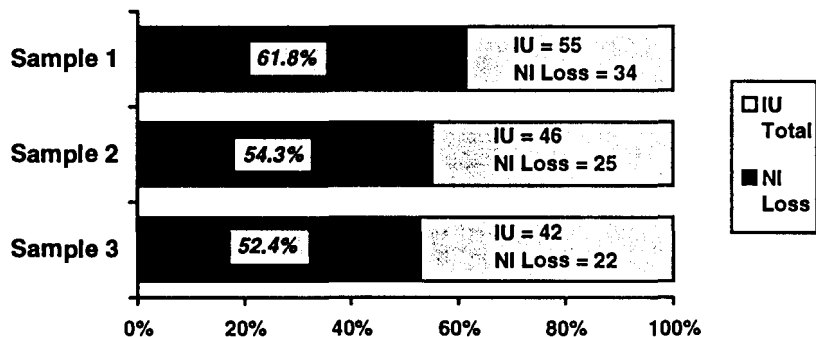

Figure 26
Instances in percentage of corrupted information structure in each sample

If we take each sample as an absolute entity by itself regardless of the number of IUs it possesses, we have the basis to compare the three samples with each other as to the severity of the loss of information focus and content in percentage. From Table 26, it is easy to see that, in all three sample dialogues segmented in IUs, **over 50%** of them have missed out the NI, either in situ or in existence. Instances of partially dislocated or misplaced NI are not taken into account; in other words, there are a very meagre number of FDT1 segments that have the close match with the original in terms of information flow.

Apart from this serious problem, there are mistranslations that are unfaithful to the original by the linguistic, stylistic or pragmatic standards, most of which are not just relevant to

dubbing. Although errors and mistakes exist in any translation, the fact that they occur with such frequency and regularity in FDt1 is worth investigating. From Figure 27 below, we have a clearer picture of the mistranslation ratio in each sample and the overall condition of FDt1's fidelity to the original.

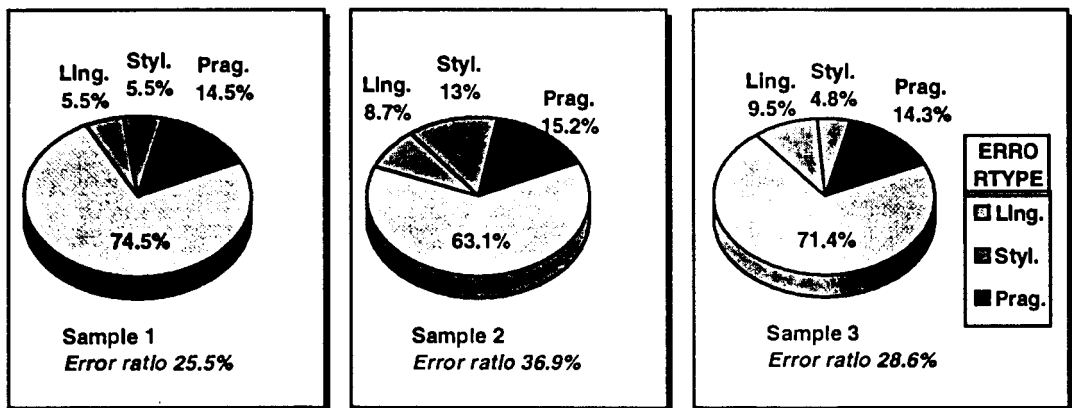

Figure 27
Percentage ratios of mistranslations and the distribution of the error types in each of the three samples in comparison

In spite of differing in quantity of IUs, all of the three FDt1 samples suffer a high percentage of loss or distortion of meaning. This is surprising either by the standard of the basic FITNESS required of dubbing or in view of the prestigious status of FDt1 as being an award-winning *yi`zhi`pian`* (dubbed foreign language film) and home-video title at the national level¹¹. The mean of the error occurrence rate is 30%, which is in conformity with the average of the mistranslations collected from the whole teleplay.

Examples of glaring errors found in other scenes, of the linguistic category, include hen`duan`de ming`dan` (a very short list) for **shortlist**; Ni`men fang`song` fang`song` (you take a relaxation) for **take it easy** and Ni`ba`wo`nong`de jing`shen`shi`chang`le (you have made me a lunatic) for **You made me crazy**. For those stylistically unacceptable ones, these are more typical: xin`gan` (a term of endearment suggesting a man's possessive desire and, usually exaggerated passion, for a woman, which sounds out of place in the kind of relationship between Jack and Jackie) for **sweetheart**; bei`bu` (a scientific term for 'a person's back') for **back** which is being used informally in referring Jack's pain in the back and Wo`zhi`dao`ta`shi`ping`an`wu`shi`de (I knew he was safe and sound) for **I knew he would be alright**. As for those pragmatically problematic translations, the follow segment provides a telltale instance of the functional failure:

Jackie:Sc. 2-5.3

[Palace of Versailles, Paris. Jack is on a state visit to France with Jackie. Jackie

dances with De Gaulle, the French President, while Jack is dancing with a beautiful woman. She then wanders into the adjacent room and marvels at the magnificence of the architecture, where Jack joins her. Both of them are in a very good humour.]

1. JACK: Hi, you had De Gaulle eating out of your hand. He actually smiled once or twice.
2. JACKIE: I think he's quite charming, in a majestic sort of way.
3. JACKIE: Oh? Attracted to him, were you?
4. JACK: Not as attracted as you seemed to be to the wife of the whatever that you were dancing with. The dark lady of the finger waves...
5. JACK: Duty dance.

The following is FDt1 (the left column) in parallel with FDt2 (the right column) for this dialogue. Both scripts are in their untreated form:

1. JACK

Wei ` , ni^v ba^v Dai • gao • le nong` de
Hi you → De Gaulle make ASP

shen`hun`dian • dao^v le. Wo^v zhu`yi`
infatuated ASP I notice

dao` ta • zhen • de xiao` le yi •
ASP he genuinely smile ASP one

lian^v ci` .
two time

Hei ` , ni^v ba^v Dai • gao • le nong` de
Hi you → De Gaulle make ASP

shen`hun`dian • dao^v le. Ta •
infatuated ASP he

ke^v zhen • xiao` le yi • liang^v ci` .
indeed smile Asp one two time

2. JACKIE

Wo^v jue` de ta • xiang • dang • ke^v ai`
I find he quite lovely

hai` you^v xie • wei • yan`
also have some majestic dignity

Wo^v xiang^v ta • ting^v you^v mei` li` ,
I think he fairly have charm

you^v wei • yan` de feng • du`
have majestic MOD manners

3. JACK

Ni^v bei^ˊ ta • gei^v xi • yin^v zhu^ˊ le.
you → he PAS¹² attract -ed ASP

shi^ˊ ma?
isn't it

A, mi^ˊ shang^ˊ ta • le, shi^ˊ ma?
oh attract -ed he ASP isn't it

4. JACKIE

Hai^ˊ bu^ˊ ru^ˊ nei^ˊ wei^ˊ he^ˊ ni^v
yet not than that MSR with you

tiao^v wu^v de bu^ˊ zhi^ˊ shen • me^ˊ
dance MOD not know what

ren^ˊ de tai^ˊ tai^ˊ na^ˊ me^ˊ xi • yin^v
person MOD wife that attract

ni^v ne.
you MOD.

Mei^ˊ na^ˊ me^ˊ zhao^ˊ mi^ˊ, xiang • ni^v
not that attracted as you

dui^ˊ nei^ˊ wei^ˊ fu • ren^ˊ, bu^ˊ zhi^ˊ shi^ˊ
to that MSR wife not know be

shei^ˊ de, he^ˊ ni^v tiao^v zhe^v wu^v...
whose with you dancing

shen • fu • se^ˊ de, huang^ˊ shou^v zhi^v de...
dark-skinned MOD wave finger MOD

5. JACK

Na^ˊ shi^ˊ zhi^ˊ ze^ˊ de xu • yao^ˊ.
that be duty MOD need

ying^ˊ chou^ˊ er^ˊ yi^v
courtesy only

The differences between the two translations of this segment are considerable. Leaving aside other problems that FDT1 has tended to be obsessed with and that FDT2 is generally free from, FDT1 version has damaged the touch of humour in this dialogue with ambiguous expressions and too serious a tone (especially in effect in Turns 1, 2 and 4). Pragmatically, it is questionable in conveying the right functions and has at least two accounts of mistranslation (in Turns 1 and 4; not including the missing of the translations for 3 places in Turns 3 and 4). Such indicative misrepresentations of the

SLT in the pragmatic dimension are found more numerous in the teleplay as a whole than the other two problem areas. According to our observation on the 3 samples (see Table 27), such errors occur in close to **15%** of all the IU segments of each of the dialogue without exception.

Having compared the results from the analyses of the 3 samples and found them consistent in reflecting the overall findings of the whole test case exemplarily, we are now in a position to make general statement of TQ assessment of FDt1.

The methodology that FDt1 sticks to is one representing a TS-uninformed, pre-linguistic-era translation approach that rigidly takes the sentence as the unchanging unit of translation and favours the traditional literary translation strategies in pursuit of a stage-sounding dramatic style by written grammar regardless of the dynamic features of film spoken discourse. On the other hand, within the confines the sentential rank, it tends to allow too much liberty in being able to render the minutest details of the original sentence in a TL-oriented free manner.

Throughout the whole teleplay, FDt1 is presented in a strict sentence-to-sentence translation format that matches up with the number of FDs segments with end-of-sentence punctuation (a full stop, a question mark or an exclamation mark). The word order within a sentence in FDs is tailored or permuted after the translation to meet the standards of the grammar of written Chinese. For example, the positions of the elements in FDt1 that correspond to the Wh-questions, relative and adverbial clauses, or prepositional phrases in FDs, are generally reversed in a sentence. Other than being driven by the syntactic constraints, there are frequent motivated restructuring of the original form to domesticate the translation. Information focus and prosodic message are thus ignored outright, and so it is impossible to fit FDt1 in the FDs IU pattern and locate the information emphasis in each of the chunks or spurts of words that pace the original speech.

The consequences are disastrous: nucleus-sync or NI-sync is lost most of the time and the constraints on timing and the coordination between the spoken words and non-verbal language are obviously not heeded by and large, except for the remedial treatment of lip-synchronization out of

pure technical considerations. Putting readability over performability, such translation might sound "smooth" as a dramatic text for reading in isolation from the picture, albeit the unnatural style and the missing, even incomprehensible, information on page; but on stage, it is, in their awareness or not, a cluster bomb of words to the viewers.

Therefore, we may conclude that FDT1, as a translation for dubbing, has not been successful in representing FDs faithfully by the general standards, despite the translator's effort to dilate on what is understood of the original through a stringently one-to-one meaning transfer at the sentence level. By slighting the function of intonation means in FD and its relation to spoken language translation, as well as the media constraints on film dubbing, it has partly damaged the original dialogue. As our study shows, the formal and functional mismatches between FDT1 and FDs are so considerable that it has virtually misled the audience into a linguistically distorted Chinese version of the teleplay. All in all, it has failed to hit the goals set by the FITNESS criteria.

In contrast, FDt2 makes much more sense to go with the motion picture. It is an SL-oriented translation but never ceases to be of good colloquial style judged by the grammar of spoken Chinese; and more significantly, it is well-merged into the dramatic world with the original information flow. Hence, it is fit for dubbing.

Chapter 5

NOTES

1. Although my dubbing-ready translation of the teleplay has not been used as a performing script, it was based on the successful translating and dubbing experience of another of my translations using the same translation method. This latter case is my three-month collaboration with the GDTV dubbing team for the revoicing of the English dialogue in the American teleplay *A Million-Dollar Face* (March - June, 1994) on my translation script.

2. A shooting script is written before a film is shot; a continuity script comes after. The making of a film, from its shooting to the final editing, undergoes constant changes from what is planned in the shooting script. There are always discrepancies between a shooting script and the film in its released form. Even the final revised version of a shooting script is no guarantee of absolute accuracy between what is read on the page and what is heard and seen on screen. The dialogue in a continuity script, on the other hand, is accurate to what is spoken in the teleplay.

3. Later in July 1996, thanks to Mr. Walt Hoylman, the Sound Mixer of the Mini-series *Jackie*, who supplied me with the revised version (June 1991) of the original shooting script, I was finally able to complete my transcript of the dialogue.

4. Within the time span of each turn, FDt1 is generally more 'packed' in number of syllables than FDt2, and may contain more IUs with shorter pauses

in between. For the purpose of parallel comparison, the segmentation of FDT1 into IUs hinges on their corresponding FDTs IU time slots under which each segment of FDT1 may consist of more than one IU, but consistently matches the ranking of a syntactic constituent.

5. Dislocation of the NI here is identified on the grounds that the timing for the NI to occur in a FDT IU should not allow a tolerance of more than 4 syllables off the original locus, hence the criterion adopted for this analysis.

6. The symbol ← in the subscript indicates the double-underlined word above it is used together with preceding word(s) underlined as an inseparable unit. In this case, *lian'* ... *ye~...* is a collocation.

7. It stands for a 'mood word' that shows the speaker's attitude, or functions as an intensifier at the end of an exclamation or a statement. **Ne** is such a form word attached to a declarative sentence to be more affirmative; it should be distinguished from **Ne** the question marker (Q).

8. The "*shi`... de*" construction in Mandarin involves the use of the focus marker (F) *shi`* in conjunction with *de* the topic marker (T) "to highlight the unmarked information focus in the original" (Wu 1996:289).

9. Cf. Note 3 above. The "**verb + de (T) + shi` (F) ...**" construction is a common topic-focus pattern

in Chinese which corresponds to the English pseudo-cleft sentence.

10. The grammatical word *you`* is used in a rhetorical question or a negative sentence to add more emphasis. Words of such function are marked as **NEG** in the word-for-word translation for FDT text.

11. The same FDT1 entitled *Zong`tong` Fu`ren`* (literally, "president's wife"), which is the TV transmitted version of Jackie dubbed in Mandarin Chinese, was renamed *Di`yi` Fu`ren`* ("first lady") as a homevideo title produced by the Hubei Provincial Audio-visual Production Company in 1994 and won the Best Audio-visual Product Award (*Zui`jia` Yin`xiang` Jiang`* of the year) issued by the central government for its nationwide popularity in China.

12. **PAS** means passive voice structure. A common collocation is *bei` ... gei` + verb zhu` le* (be + Past Participle by ...), as used in this sentence.

Chapter 6

IMPLICATIONS FOR SUBTITLING

6.1 Speech and Writing

The implementation of the FITNIATS model in the test case Jackie has attempted to demonstrate its effectiveness in applying the FITness criteria for translation and evaluation in the context of English-Chinese FD dubbing. The implications of this innovation for subtitling deserve a concentrated look. In this chapter, we will focus on the issue of applicability of the FITNIATS model to subtitling in an attempt to confirm in theory our hypothesis that dubbing and subtitling can be accommodated in the same translation methodology and guided by the same FDT principles formulated by our model. To validate its potential value in optimizing subtitling translation and TQ assessment, we will demonstrate the common ground underlying these two mutually exclusive modes of FDT. First we need to identify film subtitles as a special type of translation which is distinguished from, but not in opposition to, dubbing, in the same way as writing may be distinguished vis-à-vis speaking.

6.1.1 Subtitles as Mixed Language

Subtitles, because of their written form, are easily confused with writing as distinct from speech. Subtitling is speech written down in a different language and presented simultaneously as the speaking happens. Such a special translation activity predetermines subtitles being a mixed medium of an intermediate style of speaking and reading.

In contrasting speech with writing, Miller (1994) enumerates the following five major properties distinguishing spoken from written language:

First, informal spoken language is produced in real time, ...

Second, spontaneous speech is subject to the limitations of short-term memory, which reinforces the no-editing effect.

Third, speaking is much faster than writing, ... That is, listeners must process instantly a rapidly produced and evanescent stream of speech, a task facilitated by simple syntax and simple vocabulary. ...

Fourth, spontaneous speech is typically produced by people talking face-to-face in a particular context. It is accompanied by gestures, eye-gaze, facial expressions, and body-postures, all of which signal information. ...

Fifth, ... spoken language, ... possesses resources of pitch, amplitude, rhythm, and voice quality (p. 4302)

These properties that mark informal spoken language are not found in written language. Since the relationship between dubbing and subtitling tends to be compared to that between speaking and writing, we may challenge such an analogy by measuring subtitles against the above speaking-only features.

Film dialogue is not spontaneous spoken language, but it aims to sound as such. If we take dubbed FD as corresponding to the speaking end of the dichotomy, we can't place subtitles at the other end, for the reason that none of the five distinctive features listed above excludes subtitles. First of all, subtitles are delivered in real-time and accompanied by extralinguistic and prosodic features of spoken language; and the perception (reading) of them takes place as swiftly as listening to the dialogue that is written down in simple colloquial style. Besides, both dubbed dialogue and subtitles stay in short-term memory in the receiver and are designed to appear incremental in their production to reflect the unplanned

features (no-editing effect) of natural speech. Finally, prosody is visible in subtitles through the orthographic indications of the pacing and emphasis of the information structuring that are "deducible from the grammatical properties of the writing" (Davies 1994; see also Viezzi 1993; Fries 1992; Chafe 1988) as well as the available photographic translation means which aim at counteracting the limitations of written dialogue in reflecting its innate prosody (Karamitroglou 1998).

Therefore, defining film subtitles as bona fide written language that is diverted from and incompatible with the spoken words in dubbing is erroneous and detrimental to developing FDT theory and practice.

6.1.2 Subtitling as a Special Type of SLT

In analysing variables which affect the translation process, Sager (1989) reveals the relation of the form and type of the translation to the communicative status of the translation. On the one hand, the former is described in such summary terms, "[t]ranslation can ... be full substitutes of an original with the same range of functions and readership or derived texts which co-exist with the

original involving two processes, e.g. a translation and a reduction." (p. 93). On the other hand, three general types are identified in the latter, with Type A being defined as "a full substitute for the monolingual reader", Type B as "an alternative to the original ... [which] co-exists with it" and Type C as "a full equal with the original in all respects ... [which] may therefore serve as a basis for other translation" (ibid.).

This description applies to the actual situation of FDT in that it has immediate implications in two respects: (a) dubbing and subtitling fit in the definition of the two major types respectively, i.e., a full substitute of the original and a reductive text co-existing with the original; and (b) dubbing and subtitling texts can be developed from the same full-functional translation as a standard base (as distinguished from the traditional 'rough translation' which generally functions only as an interpretation of the original and needs to undergo drastic changes before being turned into a text suitable for dubbing).

Translating a film entails making a choice between either replacing the original language with a

translation (dubbing) or retaining it in co-existence with a translation (subtitling and voice-over). The translation can be delivered in either spoken or written mode. But the fundamental principle involved in both cases is the same: striving for the equivalent effect produced by the closest match possible in informational and interactional dimensions between FDs and FDt. The FIT-oriented analysis-transfer-synthesis translation procedures apply to the formulation of a technically unrefined or untreated translation as the basis for either dubbing or subtitling as end products.

The dubbing text is in a sense a full translation of the original dialogue including the prosodic features. Subtitles have to make constant use of meaning-dense lexical items and other elliptical means to compact information from rapid speech and leave room for occasional short cultural footnotes at the expense of the colloquial style. However, both methods of film translation must stick to the objective of reaching as nearly as possible the high-water mark of the FITness criteria to arrive at the optimal translation equivalence in form and functions including the original rhythm and information focus. Therefore subtitles can be seen

as a special skeleton dialogue text derived from a full (not necessarily performable) TT text after the medium-driven lexical reduction and structural condensation. In this sense, subtitling can be regarded as a special type of spoken language translation that shares the major properties of real-time speech translation with, for example, simultaneous interpretation.

6.2 Dubbing and Subtitling

It has generally been the case that dubbing and Subtitling have been treated as completely different activities representing different categories of translation process and product. Emphasis has been unduly laid on the technicalities of these two different methods of language transfer, despite the fact that both endeavours start from the same audio-visual source and end up with the same 'spoken language' in terms of rhythm, mechanisms, functions, main stylistic features and information contents, as the original, even though in different language genres. Too much focus on their different characteristics has led to a failure to seek common ground on which these two seemingly incomparable forms of language transfer may be considered as a unified type of translation. For example, the relation between word order and

new/given information distribution in the original film dialogue should be retained in TL in both spoken and written forms on screen. Related to this topic, segmentation principles applied in the course of analysing and grouping the original spoken words into minimal units of translation (including the spotting process for both dubbing and subtitling) should be consistently and simultaneously information-dictated, irrespective of the genre difference of the target language.

In short, the trend towards plunging dubbing and subtitling into total opposition or dissociation in FDT studies should now be queried. The relationship between these two separated film translation activities should be redefined in a new research context, which transcends the media-driven economic and technological dimensions.

6.2.1 Subtitles out of the Dubbing Script

As mentioned in the Chapter 1 of this thesis, so far in mainland China, there has been no specialized subtitling company nor such a department within a television station or a film studio. Subtitled versions of foreign movies or television dramas are produced by these professional film translators only occasionally for

foreign language learning or promotion purposes. The standard practice of subtitling a feature film or a teleplay for showing on TV is simple and direct. The translator marks off what he/she thinks to be viable subtitles on the dubbing dialogue list in semantically self-contained segments for no more than 13 Chinese characters' apiece, with a requirement to minimize empty words, such as interjections, and certain address forms, appositives, mood indicatives, parenthetic remarks and repetitions if there is conflict with the wordage limit; then the 'raw subtitles' are keyed line by line into a computer and projected to the relevant frames with adjustment in wording and speed to keep to the speaker's timing. Thus by utilizing the dubbing script and combining the spotting, adaptation, insertion and correction into one step, this practice inverts the normal subtitling procedures in that composition of the subtitles anticipates the initial decision on what and how words should be extracted from the original dialogue to adapt to a particular series of frames.

This phenomenon has confirmed the need to field crucial questions as regards: Is it necessary to distinguish subtitling from dubbing as different

types of translation? If there is established common ground which subsumes both dubbing and subtitling under FDT, can our translation model be useful for both dubbing and subtitling? To what extent can subtitling copy dubbing lines?

The practice of direct use of a dubbing script simply by clipping on the less important words immediately calls into question the status of the dubbing script itself and the applicability of the normal reduction (adaptation) principle. Leaving aside the existing problems of legibility and readability caused by this subtitling method and its consequent damaging effect on the original story, the expediency of using the same translation for dual purposes and the stable ratings of this type of programme kept by the Chinese viewers do have their positive implications.

Practically, it can be an economical solution to different audience preferences for either a dubbed and subtitled version of a film provided such a need statistically merits the creation of the latter. Theoretically, the main semantic content and the information focal point of each spoken line should be rendered into subtitles in keeping with the word order and timing of the original film

without much difference from preparing a translation for dubbing. Technically, being a full translation of the dialogue, the script for dubbing can serve as an ideal base from which subtitles are 'tailored out', given the dubbing script per se be stylistically and cognitively viable and the subtitler adopt appropriate strategies and techniques to proceed, such as carrying out spotting (for subtitling) prior to the segmentation of the dubbing script and further trimming it down with a fair amount of clipping and condensation to meet the spatiotemporal demands special to subtitling. Thus the hypothesis that quality subtitles can be composed directly out of the dubbing script of the same film and both dubbing and subtitling can benefit from the same raw translation as the starting point leading to further modifications under each other's own medium context, is furnished with positive evidence from this practice.

6.2.2 Applicability of the FITNIATS Model to Subtitling

The viability of the FITNIATS model consists in its theoretical probity which has been initially attested in this study. By incorporating the IF theory and the relevant findings from research in TS, linguistics and media discourse into one

translation scheme, the model, with its multi-disciplinary bearing, holds a confirmed edge in translating and assessing film dialogue.

While the operation of our model on dubbing has been proved to be effective, its applicability to subtitling as an equally legitimate art of translation is yet to be validated. The status of subtitling as such in FDT needs to be further clarified to dispel the myth that subtitling, because of its condensed form, is inevitably reduced to a type of interpretation rather than translation in the same sense as applied to dubbing.

In a subtitled film, the original dialogue soundtrack co-exists with subtitles, which makes them not only seem accessory but also liable to criticism from anyone familiar with the SL, should inaccurate or mistaken translation occur. At the same time, the translator/subtitler must fit the subtitles into the limited time/space available to match the picture with good timing. These constraints have led to a misconception that the translator for subtitling is entitled to more flexibility in representing FDs with much greater freedom and vagueness than the dubbing translator

who is committed to restoring a full dialogue text. The fact that the translator necessarily has recourse to omission and compression as the prevailing translation strategies to shorten the dialogue lines in a large measure does not justify the devaluation of subtitling from the status of a full-functional translation. The reduction in subtitling should be an outcome of trimming down on a complete and faithful translation, be it in its physical or conceptual formulation.

Apart from the spatio-temporal constraints on the presentation of subtitles, a commonly neglected factor that necessitates the reduction is due to an extra cognitive burden on the receiver of subtitles that affects their comprehension speed. Contrary to the relevant findings in the standard speech vs. writing theory (see, e.g. Miller 1994), reading subtitles is not faster than listening to the on-going film dialogue in most cases, because the perception is subject to a process of synthesis of all the codes received from the film, including the original dialogue soundtrack. In both cases of dubbing and subtitling, the audience always surrenders the priority of their attention to the main information input, the message from the visual, while matching it with what they hear or

read from the translation being provided. In watching a dubbed film, with no original prosodic clues present, what is perceived from the dubbed dialogue tends to be readily absorbed in the audience's consciousness, unless the translation is too wide of the mark.

Subtitles are projected with the original dialogue in the background so that the intake of the lexical meaning is constantly influenced by the prosodic modulations of the voice being heard, which is a more imposing signal in construing the picture. As long as the dialogue is heard, it unavoidably works in the audience's subconsciousness to either facilitate or hamper the comprehension of the dialogue, even if they have no knowledge of the SL. Sustained lengthy and unduly frequent subtitles add more burdens to the synthesis effort and greatly increase the chances of mismatch between the words read and tones heard. By reasonably shortening the length of subtitles and increasing their duration, the information from the background voice can work to the advantage of the audience for comprehending the subtitles instead of interfering with it. Therefore the legibility and readability of subtitles must be maintained in such a way that they require the least effort to be understood as

" think units" (Nörby 1998) the first time and are timed within close proximity where the saliency of the original voice that marks the information focus of the relevant unit is perceived. In serving this purpose, reduction as an indispensable means to make subtitles lexically and syntactically easy to process does not bring subtitling down to an inferior type of translation to dubbing.

Subtitling is a creative translation activity that has no fundamental difference from dubbing in terms of its translation process and quality assessment criteria. As will be shown in the following example, it is a questionable and problematic practice treating subtitling as no more than filling designated slots with telegraphic-styled text while composing them, or pruning a finished dubbing script down to a slightly smaller size without querying the soundness of such direct phonographic transfer. In both cases, spotting out of purely technical considerations has been used as the only preparation for the subtitling and the requirements for fitting the words in the time/space available, rather than the creation of subtitles per se, seem to be the translators' chief concern.

I select from the data for my related research topic an example that consists of three subtitled versions of the same dialogue segment in the American film *The Silence of the Lambs* (the 1991 five-Oscars winner; directed by Jonathan Demme; **Lambs** for short). The translations are taken from the subtitled film produced by Beijing Television in videotape (Chinese title *Chen mo`de Gao`yang`*, subtitled in Chinese in 1992; coded **FDt1**) and the one by Hong Kong ERA Home Entertainment Ltd. in VCD (same title as **FDt1**, 1991©; coded **HKsub**)². They were first shown on a CCTV³ television channel in China and the ATV⁴ in Hong Kong, respectively. My translation⁵ that is attempted to be used as subtitles of the dialogue (coded **FDt2**) is juxtaposed last to demonstrate the applicability of the FITNIATS model for subtitling.

The actual running time of the original dialogue (FDs) is cut into 14 segments representing a series of designated time slots for subtitle flashes; each FDs slot consists of one or more IUs (separated with a forward slash at the end). Each projection of subtitles takes place during the vocalization of each corresponding FDs line. If there are two subtitle flashes within that timeframe, they are marked as **-a** and **-b** respectively at the end of the

code name of the version concerned (in this example, this happens only to FDt1); on the other hand, if a subtitle line is left on the screen over two FDs dialogue lines, the code name is shaded with the arrow symbol boldfaced (in this example, only HKsub has this double retention; see e.g., under the time slots ④, ⑥, ⑧ etc.). Each pinyin word in the subtitles is underlined to represent a Chinese character and there are word-for-word translations underneath every subtitled line.

This is part of the first interchange in this film between the FBI Agent Clarice Starling and Dr. Hannibal Lecter. The "Cannibal" Lecter said the following to Clarice when she came to his asylum cell to ask him to help her find a serial killer.

[*Lambs*: Sc. 1-6]

(After he flips through the questionnaire prepared by Clarice, Lester jeers at her for being too naïve in trying to "dissect" him "with this blunt little tool". His voice remains gentle.)

LESTER

(Frame starts: 25318; Fame Rate = 23.976 Frame/Sec.)

① You're so ambitious, / aren't you...?

FDt1 → **Ni hèn you yě xīn wà!**
 you very ambitious E⁶

HKsub → **nǐ jù yě xīn**
 you have ambition

FDt2 → **nǐ hèn you yě xīn a!**
 you very ambitious E

② You know what you look like to me,

FDt1 → Zhi dao ni bei zhe piao liang bao chuan zhe lian jia xie
 know you carry ASP nice bag wear ASP cheap shoes

HKsub → ni yong gui shou dai pian yi xie de tu bao zi
 you use expensive bag cheap shoes MOD rube

FDt2 → zhi dao ni kan shang qu xiang shen me?
 know you look like what

③ with your good bag and your cheap shoes? / You look like a rube.

FDt1a → kan shang qu xiang shen me ma?
 look like what Q

FDt1b → xiang ge tu bao zi
 like MSR rube

HKsub → mei pin wei de tu bao zi
 no taste MOD rube

FDt2 → piao liang de bao , lian jia de xie , xiang ge tu bao zi
 nice MOD bag cheap MOD shoes like MSR rube

④ A well-scrubbed, hustling rube with a little taste.

FDt1 → man di shi pi yu ben ming de ren , zhen mei yi si!
 all over the place be hustling MOD people really no meaning

HKsub → mei pin wei de tu bao zi
 no taste MOD rube

FDt2 → jing xin shu li , pi yu ben ming , you dian pin wei
 well-scrubbed hustling have a little taste

⑤ Good nutrition has given you some length of bone,

FDt1 → zeng jia ying yang ye xu hui rang ni zhang da
 add nutrition perhaps will make you grow up

HKsub → ni shen ti po qiang zhuang , dan shi zhong qiong kun
 your physique pretty strong but always in poverty

FDt2 → hao de ying yang rang ni zeng gao ,
 good MOD nutrition make you grow taller

⑥ but you're not more than one generation from poor white trash,

/ are you, Agent Starling?

FDt1a → **ke shi zai ye wai e lei de huan jing zhong**
but PreP wilderness adverse MOD environment LOC

FDt1b → **ye zhi neng huo yi dai**
but only can survive one generation

HKsub → **ni shen ti po qiang zhuang , dan shi zhong qiong kun**
your physique pretty strong but always in poverty

FDt2 → **hai shi lai zi nan fang de qiong ren**
still be from South MOD poor people

⑦ And that accent you've tried so desperately to shed -

FDt1 → **ni pin ming er jue wang de ba zi ji cang zai jia**
you deparately PAS yourself hide PreP home

HKsub → **nu li bai tuo na xi Wei zhen ni ya kou yin**
try rid of that West Virginia accent

FDt2 → **ni na kou xiang yin yi zhi pin ming yan gai**
you that MSR country accent always desperately cover

⑧ pure West Virginia.

FDt1 → **jiu zai Xi Fo ji ni ya**
only PreP West Virginia

HKsub → **nu li bai tuo na xi Wei zhen ni ya kou yin**
try rid of that West Virginia accent

FDt2 → **hai shi di dao de Xi Fo kou yin**
still be pure MOD W. V. accent

⑨ What's your father, dear? / Is he a coal miner?

FDt1 → **dan ni fu qin zhi bu guo shi ge kuang gong**
but your father nothing but be MSR miner

HKsub → **fu qin shi kuang gong ? shen fen di wei ?**
father be miner status humble

FDt2 → **ni fu qin shi shen me ? shi ge kuang gong ba ?**
your father be what be MSR miner Q

⑩ Did he stink of Oleum?

FDt1 → **hen bu qi yan**
very negligible

HKsub → **fu qin shi kuang gong ? shen fen di wei ?**
father be miner status humble

FDt2 → **hun shen san fa you yan wei ba?**
all over give off oily smoky smell Q

①① You know how quickly the boys found you!

FDt1 → **ni hen kuai bei nei ge nan ren fa xian le**
you soon PAS that MSR man find ASP

HKsub → **nan hai zi kan shang ni , qi che hou gui hun**
boy choose you car backseat mess around

FDt2 → **nan hai zi qing yi nong ni dao zhou**
boy easily get you in hand

①② All those tedious, sticky fumbblings, / in the back seats of cars,

FDt1 → **qi che yao shi zai che zuo pang wu li yao bai zhe**
car key ASP driver seat side faintly dangle ASP

HKsub → **nan hai zi kan shang ni , qi che hou gui hun**
boy choose you car backseat mess around

FDt2 → **duo shao ci gui hun qi che li**
how many times mess around car LOC

①③ while you could only dream of getting out. / Getting anywhere -

FDt1 → **ni huan xiang zhe zi ji neng tao chu gu**
you dream ASP yourself can get out

HKsub → **ni zhi xiang li kai dao bie chu gu**
you only want leave for other place LOC

FDt2 → **ni zhi neng huan xiang tao chu gu**
you only can dream get out

①④ Getting all the way/ — to the F = B = I =

FDt1 → **tao chu gu , tao dao Lian bang diao cha ju**
get out escape to federal investigation bureau

HKsub → **ru Lian bang diao cha ju**
join federal investigation bureau

FDt2 → **yi zhi tao dao Lian bang diao cha ju ...**
all the way escape to federal investigation bureau

(Frame ends: 26356; duration = 43.29 Sec.)

Table 37 is a summary of the main parameters derived from this selection.

Running time = 43.29 sec.	Total # of Chinese characters used*	Number of subtitle projections	Average length (# of Chinese characters)**	Average duration of each flash (sec.)	Retention of the same subtitle over 2 time slots	Instances of 2 consecutive subtitles per time slot
FDt1	158	16	11.29	2.7	0	2
HKsub	81	9	5.79	4.8	5	0
FDt2	129	14	9.21	3.1	0	0

* A Chinese character takes the space of two ASCII characters.

** This is the average character number of a single-line subtitle derived from having the total number of Chinese characters used by the relevant subtitled version equally distributed to the 14 designated time slots.

Table 37

Spatial and temporal status of the subtitled versions in terms of subtitle length and duration

If we compare the three translations, we can find in good faith these differences:

1. **FDt1**, clipped directly from its dubbed version⁷, is wordy and has too short duration for each subtitle line (2.7 seconds on the average). Such lengthy subtitles with less retention time than normally required appear as swift flashes on the screen that strain the viewers' eye in the first place, not to mention the confusion caused by the glaring mistranslations and mismatches to the original information structure.
2. The Hong Kong version has much better readability and provides a synoptic caption for the picture clearly, though with much loss of meaning. The style of the subtitles is brief, condensed and incapable of being uttered, occasionally desirably compendious, but most of the time regrettably over-

simplified. With heavily reduced wordage and less frequent and more retentive subtitle flashes, the translation serves well as a rough interpretation of the dialogue; however, numerous cross-timeslot subtitles (in this short segment there are as many as 5 such occurrences) exceed the maximum duration (3.5 seconds) allowed for a subtitle line to avoid automatic re-reading of the subtitles which is to "generate feelings of distrust toward the (quality of the) subtitles" (Karamitroglou 1998) among the audience.

3. FDT2 retains the original rhythm and the NI positions faithfully and it is a fuller translation than the other two versions with close match to the 14 FDs segments in meaning and timing. Maintaining an appropriate pace and length, the subtitles are delivered with easy readability while keeping the colloquial features of the original spoken lines. There are no double flashes in the same timeslot nor lagging-out time, with the average duration of a subtitle line being 3.1 seconds. Therefore, it shows a fine balance between retaining a maximum of the FDs content and leaving the viewer adequate time for the synthesis of all the available information from the film, hence potentially an ideal subtitled version in dynamic and communicative equivalence to the original dialogue.

From the illustration above, we can sense the potentiality of the FITNIATS model in serving

subtitling as effectively as it does dubbing. Nevertheless, the actual subtitling circumstances invite more challenges than the mere conceptualization of the factors that affect the quality of a subtitled product can meet. The art of subtitling in terms of its practical technicalities is a sophisticated area of knowledge in its own right, which is beyond the scope of this discussion. What is attempted here is to explore the possibility of relating the norms of subtitling set by the international standards to the practicability of specific strategies for overcoming the linguistic and technical constraints as relevant to the English-Chinese subtitling in the context of the FITNIATS model. The heavy constraints subtitling is under can be exemplified by the following fact. To quote Nörby (ibid.):

The TV translator has got two lines of 34 spaces each to summarize what is said in 6 seconds. The work thus has its restrictions. I may have found a smashing phrase - and then it is one letter too long.

Despite the medium differences, the application of our model to dubbing and our initial experiment in the case of subtitling the *Lambs* have promised good implications for subtitling in that dubbing and subtitling as different end products of FDT can be

unified in the same translation activity, and that it is achievable that subtitling be processed in the same film translation theoretical framework that transcends the differences between dubbing and subtitling in form and formulation. Both of them belong to a bona fide translation type while being technically constrained in their own ways with respect to representing the original dialogue. The goals set by the FITness criteria for attaining equivalent effect in FDT prevail over the preoccupation with the electronic aspect of subtitling and can be expected to be realized in the general practice of translating and evaluating of subtitles as the alter ego of dubbing.

6.3 Summary

In order to make a dialogue translation operational in the genre-specific environment suitable for either the lip-sync spoken words or the shifting written text, special considerations and treatment are required of each of the two modes of FDs representation, which result in two distinctive sets of working procedures. The centre of the concern in these cases is, for dubbing, the principle of synchronization, whereas for subtitling, it is the principle of reduction.

However, traditional film translation theory and practice, overwhelmingly influenced by the conflict arising from the dub-sub preference, tend to exaggerate the "essential discorrespondence" (Haas 1970:passim; e.g., pp.85, 86) between the two media while losing sight of their common ground in translation methodology. So much emphasis has been laid on the eventual presentation technicalities as well as economic aspects including production cost and commercial practicality that it seems as if there were little for dubbing and subtitling to share in the translation process.

Dubbing and subtitling differ in the mediums used in the translation situations (spoken-to-spoken vs. spoken-to-written). But both have the identical source language to work on and both represent or enhance the speech code as an integral part of the whole audio-visual discourse. Subtitling is in essence a simultaneous translation or, in a sense, a refined spoken dialogue transcript. Subject to the medium constraints, it is intended to be only a semi-verbatim rendering; however, the basic rhythm, structure and stylistic features of the original dialogue should be reflected to a maximal degree in the subtitles in order to meet the FITNESS criteria. From the IF point of view, this desired

goal can be realized to a satisfactory effect notwithstanding the contextual constraints particular to the subtitling process, viz.,:

- genre crossover restrictions - certain features of speech have to be represented in the TL in written form, such as non-standard usage, dialectal variation and varying levels of colloquialism;
- physical constraints of available space;
- the sequence of speech acts that has to be perceived as it occurs through synchronized subtitles;
- the overall coherence to be ensured despite the brevity of each dialogue segment; and
- Limited means to reflect stress and intonation and other prosodic features.

As a matter of fact, the tension between reaching for the goal to produce the nearest possible communicative equivalence to FDs that subtitles can potentially represent and overcoming the resistance produced by those constraints can be alleviated by using the FDT methodology being proposed in the present study.

This is because, first of all, the essential parameters embodied in the FIT principle as targeted TE are attainable in both dubbing and subtitling:

F - information and its focus and distribution in an IU;

I - prosodic features including rhythm, stress, pause and tone, naturalness in spoken language, word-visual harmony;

T - coherence, textuality within and between speech act sequences.

Directly or functionally, the transference of these elements into the dubbed dialogue or subtitles proceeds with a well-defined and effective translation procedure, which is based on the IF canon as applied to film translation in both cases - sticking to the NI focus in each IU in sync with that of the original dialogue.

Secondly, prosody in spoken language, including film dialogue, is a functional property that is the key link between the autonomous dimension and communicative dimension of the discourse. Even though intended for sight interpretation instead of oral performance, subtitles should convert the key prosodic features into their equivalents that are available in written language, which can also have a considerable theme-reinforcing and mood-creating functions, to mitigate the consequence of having to reduce words and intonation in the subtitling context. As pointed out before, the vocal code is the only textual variable of FDT so that words and

intonation are the two major components of film dialogue that are relevant to translation as product. In subtitling, since neither component can be fully transferable into subtitles, especially the intonation that goes with the spoken words, it justifies the need for more accurate picture-subtitle co-ordination and confirmation by keeping to the original rhythm and the locus of the tonic syllable(s) of the key word(s) in subtitling to match the image on screen especially non-verbal language.

Thirdly, only by applying such an IU-timed, NI-sync translation procedure to subtitling can subtitles and the original dialogue soundtrack be merged into a complementary whole to compensate for the intonation loss since subtitles as written text also need to be 'dubbed' with a tonal dimension by the accompanying vocalization. Disregarding the synchrony between the written words and the corresponding spoken words can only cause discord, confusion and even misunderstanding, even though the latter is subconsciously perceived by the foreign audience.

Lastly, our model for FDT is based on the theories which pertain to spoken language translation in

general and dubbing in particular. Nevertheless it is conceived of as valid and effective for subtitling as well, also because dubbing and subtitling as different forms of translation from the same source can start with "a full equal with the original" as the basis (Cf. Sager *ibid.*) on which a genre-oriented translation for revoicing or subtitles is formed. The central theme of MT, the analysis-transfer-synthesis (A-T-S) procedure, is adapted for the three corresponding modules that comprise our model, involving a multi-level, top-down and bottom-up A-T-S process, appropriate for either form of film dialogue translation to go through, even though they need to undergo special medium-driven treatment to be finalized after the requirements on various levels are basically met. In other words, the formation of a preliminary translation (physical or conceptual) is not mode-specific, but it is necessary to serve as an ideal basis suitable for both dubbing and subtitling.

In sum, one of the concerns of this thesis is to find the common ground for both dubbing and subtitling as translation process. It has attempted through this chapter to clarify the implication that our film translation model with FIT as the main thrust can accommodate both dubbing and

subtitling in the same translation procedure as far as the fulfilment of the essential stages of analysis, transfer and synthesis prior to the stage of adjusting the base script to the special contextual and formal demands on either mode. The significant change lies in adopting the fundamental principle of using the IU as the unit of translation in the subtitling process as in dubbing, with the consequent changes in the principle of spotting and the approach to the genre crossover steps, that is, whether it is necessary to reach an unabridged version before turning out a reductive text. This two-step rendering, under the normal circumstances, can be combined in a single process with the fuller NI-anchored translation formed in the subtitler's consciousness only; but it is a step to be taken in order to maintain FITness in subtitles.

Thus, by keeping the standard subtitling working routine undisturbed in that subtitles are composed directly from the 'spotted' FDs script through keying in the translation against the sound and picture on screen, the change only takes place in methodology rather than in actual methods - it adds a prosodic (communicative) dimension to subtitles without coming into conflict with the

established subtitling principles and strategies. So there is reason to believe that unifying two working procedures of dubbing and subtitling into a translation model by taking the common point of entry and following the same A-T-S procedure with different emphases and technical modification will result in a more efficient, adaptable, hence more economical⁸, methodology. After all, from the functional point of view, dubbing and subtitling belong to basically the same type of translation that ends up in different medium forms.

Chapter 6

NOTES

1. A Chinese character takes the space of two typographical characters, or two computer letters in English.

2. The reasons for selecting these two translations for my research are similar to those stated for Jackie. Apart from their qualification for representing the state-of-the-art subtitling for television in China and Hong Kong, as they are the products of two prestigious television stations, as well as the weight and the good quality of the dialogue in the original movie; it is also because the subtitling skills and techniques in Hong Kong are in general more advanced than those of the mainland China and deserve translation studies, especially in comparison with the mainland.

3. The China Central Television Station.

4. The Asian Television of RTHK.

5. My translation of *Lambs* representing the improved subtitled version is the outcome of employing the new methodology initiated in this study which has been found to be consistently valid and reliable under the FIT theory and in comparison with the original dialogue and the two other broadcast translations throughout the experimentation I carried out on the entire film.

6. Exclamatory particles in Chinese attached to the end of a sentence are marked as **E**.

7. *Chen Mo`de Gao`yang`* (silent lambs), *Yi`zhi`pian`* (dubbed film) No. 6 (1992), Translator: Lan Qing;

Dubbing Director Peng He, Producer: Li Zi, Beijing Television, 1992.

8. Taking the unified procedure as a whole, there will be no extra cost incurred for subtitling.

Chapter 7

CONCLUSION

7.1 Concluding Remarks

This study attempts to propose a new approach to foreign-language film/TV translation in the context of investigating English-to-Chinese dubbing both as process and product. The main outcome resides in the initiation and validation of a pragmatic model for film dialogue translation and quality assessment. Through analyzing and comparing authentic film dialogue scripts and their translations in the perspective of information flow, this corpus-based study has testified the applicability of the FITNIATS model that is based on the relevant theories of functional linguistics. It has demonstrated that an effective key to improving the unnatural and misleading "translation talk" which is widespread in English-Chinese dubbed films and TV dramas lies in the change of the translation approach and methodology. With consistent evidence from the test case *Jackie* and other samples cited in this thesis, it has shown that film translation should not be treated as pure text translation without transferring the prosodic

properties of the original film dialogue into the commensurate functions of TL. It argues that, in order to reduce confusion and loss of meaning/rhythm in dubbing, the SL dialogue should be rendered in intonation units with the stressed syllables well-timed in TL to keep the corresponding information foci in sync with the visual message.

The consequences of divorcing the translation from the oral presentation of film dialogue are held accountable for the various translation problems in the Chinese dubbing. It has been made clear that such practice stems from the approach that views dubbing as no more than a dramatic voice recreation wherein the interpretation of the prosodic message of FDs is beyond the translator's responsibility that is only to 'tell the story' by the written script in TL. However, dubbing as a special genre of spoken language translation cannot afford to slight the instrumentality of prosody in its translation process, because the final 'on-line delivery' of the spoken words in TL is configured by the FDT script which has the potential power to enable or disable the dubbing voice to match plausibly the corresponding visual allusions that reveal mood, tone, body language, emphasis in an

information unit and the sociolinguistic features of the characters "miming" on the screen.

In the case of dubbing from English to Chinese, it has initially been confirmed that conveying the prosodic information to the fullest extent possible from FDs to FDt, such as rhythm, pause, stress, duration, and other intonation means, is significant and feasible in retaining the original effect of the sound and image working synchronously to achieve a faithful and artistically-qualified translation end-product. The original FD functions may devastatingly collapse in FDt if frequent disharmony occurs between the voice and the picture in these respects.

One of the innovative contributions this research intends to make to FDT theory is the justification of the necessity and viability of establishing the intonation unit as the unit of film dialogue translation. As expounded in Chapters 3 and 4 and illustrated in Chapters 5 and 6, using the IU as the micro-level unit of information transfer not only makes the optimal formal correspondence between FDs and FDt possible, which is necessary in FDT; but also facilitates the realization of the macro-level functions.

This represents a major shift in thinking from the relevant theories on UT. At least in dubbing and subtitling between English and Chinese, the sentence has been unchangingly and exclusively used as the unit of translation. Rigidly sticking to the sentence to sentence formula as the translation metastrategy while ignoring the information structure of the spoken discourse has resulted in serious stylistic as well as communicative problems as our data analysis shows. From the outset, this thesis has queried the appropriateness of such praxis and underscored the need for an FDT theory that is informed by a well-conceptualized grammar of spoken language; and has proved its great value in offering the screen translator a functional measure for processing information in a new perspective and presenting FDT in an incremental manner in keeping with the modus operandi of spoken language production and spoken language translation.

Taking the IU as the unit of FDT is identified as a step forward towards merging this new concept and practice into a converging definition of the unit of segmentation and the resultant methodology which operate effectively in the fields of SLT, MT and NLP. Being designed as naturalistic speech par

excellence, film dialogue works consistently in the same structural and functional patterning as spontaneous discourse; and the translation process can thus be guided by the same principles on speech conversion and generation as applied to the above related disciplines. On the other hand, unlike unplanned speech where the goal shift and the topic flow are more unpredictable and the constituting IUs more uneven, film dialogue is more purposefully organized. In most cases, its segmentation into the IUs coincides with the traditional division of the sentence into meaning units or sense groups on the corresponding grammatical rank. It is therefore more manageable to hold the IU as the key link between processing elements in the information structure at the micro level and those in the interactional structure at the macro level in film translation.

Missing this key link in FDT, as found in the case of FDT1, the translator tends to lose sight of the priority in FDT with respect to transferring faithfully the textual and contextual functions of FDs, while taking too much liberty in domesticating the translation within the TL sentence by either scrambling the constituent structure or changing the syntagmatic relations of the original. As a

result, the translation product fails to meet the FITness criteria on account of its high mistranslation rate in terms of inappropriate style, loss of prosodic message and information focus, and distorted meaning, including misrepresented pragmatic functions.

The research reported in this thesis on film dialogue translation falls within the boundary of dubbing, with heed also paid to the implications of the our FDT theory for subtitling. Given the scope of the project, the present study has not been able to address issues in subtitling in detail through implementing the model on English-Chinese subtitled audio-visual products. Nevertheless, it has attempted to reach an initial conclusion that the products of dubbing and subtitling are both medium-driven representations of the original screen dramatic dialogue and share most of its stylistic features and functions; and that while dubbing must approximate every aspect of the original dialogue in its TL form and function, subtitles should also aim at representing the original speech as closely and fully as possible, for subtitles as a discourse type are by nature a spoken variety realised in written words. Based on this view, the hypothesis has been advanced with due confidence that our

FITNIATS model will operate effectively on subtitling as well, to improve the translation process and evaluate subtitled products by valid and reliable criteria.

In conclusion, aiming at laying the groundwork for a new, pragmatic theory of film dialogue translation to provide answers to the urgent problems that have widely existed in the audio-visual products in China, this study has attempted to adopt a systematic and focused approach in the developing and attesting the FITNIATS model that integrates the information flow theories on spoken and written language with the relevant theoretical and empirical findings from TS and other related branches of linguistics. It has attempted to bring into attention the place of dubbing and subtitling as special genres of translation, whose relationship should be redefined with a new approach; identify the causes of the translation problems in the this field in the English-to-Chinese context; justify the needs for a new methodology and provide a promising solution. Overall, answers have been offered to the following questions: (a) what are the priorities of translating for dubbing? (b) what are the criteria for achieving equivalent effect in dubbing and how

may they be used to evaluate the translation quality of a film? What is good dubbing in Chinese? (c) to what extent and in what way is information flow theory applicable to the film dialogue translation and why might prosody be the key to retaining the information and interaction structures of original film dialogue? (d) why is the intonation unit the appropriate unit of film translation? and (e) what are the implications of this study for subtitling? The theoretical and practical consequences of the FITNIATS model may go beyond film translation in the Chinese context, which calls for further studies.

7.2 Limitations

While this thesis has sought to achieve the highest levels of comprehensiveness and relevance possible, it is important to acknowledge its limitations.

First of all, FDT studies is a fast-developing field born into an unpredictably ever-changing global environment in this fleeting information age. With growing international exchange and a proliferation of audio-visual products, services and advanced media technologies, it is literally impossible to keep abreast of the state of the art. Knowledge and techniques as well as the consumer's preferences and choices are updated swiftly in

dubbing and subtitling. The research outcome of this project needs to be followed up by further research as new literature and new practices emerge in the field.

Secondly, in testing the applicability of the theory and methodology advocated by this study, only language-specific evidence has been produced and the experimentation conducted for this study has been limited to data in English and Chinese only.

Thirdly, it must be emphasized that, in actual practice, it is essential to take into full account the end-user criteria. These are subsumed under the FITNIATS model in generalized terms, but must be specified in each individual case to be able to finalize a translation that meets the prescribed requirements of the targeted consumer or the translation initiator. In this study the end-user requirements are derived principally from the theory, the relevant literature and personal experiences; what has not been attempted here is a quantitative survey of country-specific viewers' preferences and corporate standards' .

Given that no wide audience reactions have been elicited to support the view expressed in this study with respect to the translation quality of FDt1 and FDt2², the research results lack substantiation in the pragmatic dimension. In addition, it would have been ideal if FDt2 had been presented in the actual setting.

Lastly, our analysis of the prosodic aspect of the film data has been based on the faithful transcribing and coding of the dialogue transcripts that were done strictly according to the original soundtrack of the films. However, although features of pause, stress, and duration offer the primary clues to the emphases and the general information distribution in an IU, they are not a constant parameter. The performing of the same dialogue line may vary from one dubbing actor to another, in spite of the translator's interpretation and configuration of the dialogue. To quote the Hollywood actor Matt Damon, who successfully composed the dialogue script for the Oscar-winning film in which he stars, "To have a good movie script is one thing; to have it performed in each other's own way is another."³ This point was more succinctly expressed by Walter Hoylman, Sound-mixer of *Jackie*,

" I have heard actors deliver the same lines
4 different ways each having a different
meaning that is what makes the difference
between a good actor and a great actor." 4

In getting the prosodic message from the soundtrack to analyze and assess the final product of a film and its translation, the actor's and director's freedom in acting out a dialogue script should be taken into consideration. Therefore, the location of the stressed syllables and determination of the information focus in an IU to some extent depend also on individual actor's performance, which implies the quality of a translation as indicated by its prosodic effect is a relative concept.

These limitations notwithstanding, this thesis claims to have achieved the purpose it has stated at the beginning. However, research on the basis of this study needs to be pursued further.

7.3 Recommendations for Further Research

As reiterated in this thesis, the need for research in translation studies for dubbing and subtitling between English and Chinese in keeping with the world trend in terms of the nature, focus, scope and depth of the studies in this field has become a matter of urgency, with the globalization of

cultural exchanges between China and the world and the expansion of the Chinese audio-visual market. Apart from the general information-upgrading and theory-building for China's FDT studies, there are a number of related issues specific to the country's situation that reveal themselves to be of universal significance.

Dubbing in Dialect vs. Standard Speech

Being the national 'common speech', Putonghua (or the spoken form of Modern Standard Chinese which is often inaccurately equated with Mandarin) is the designated target language for dubbing a film into in China. Dubbing in regional dialects is only occasionally seen in local television programmes. Amid the nation-wide dubbing-for-television upsurge, partly influenced by the Hong Kong practice of dubbing for television exclusively in Cantonese, the Guangdong Television started from the early 90s to produce more and more dubbed TV films and series in Cantonese to cater for the local audience.

However, dubbing in local dialect instead of Putonghua has not gained solid ground, for the prejudice against using a dialect to dub a film that is originally voiced in the standard variety

of a foreign language has been strong and widespread among professionals and audiences alike. In Guangzhou, there was a month-long public debate over this issue in the press in 1994⁵ that reflected the deepened conflict between two opposing opinions: A. versus B.

A: As the corollary of the development from the Beijing dialect and the North Mandarin dialect group plus loans from other regional dialects⁶, Putonghua is more powerful than any Chinese dialect in that it is the only variety comparable to 'the language of the mass media' of any other linguistically-diversified country. Dubbing in Cantonese to some extent ruins the original art because it is only Putonghua, not any dialect, that is on the equal footing with the original 'national' standard language (be it the BBC English, the General American, or the French of Paris);

B: A regional dialect is as legitimate and capable as Putonghua for the purpose of dubbing to achieve the closest possible linguistic and artistic effect of the original. It is meaningless to draw analogy between SL and TL in terms of official status, expressiveness and generic register, because dubbing is an illusion, unnatural in the first place, and any variety of TL chosen is but an approximation to the original.

The discussion subsided with the conclusion that it had gone beyond the scope of film translation, but the conflict is far from being resolved. It could be argued that, whether it is appropriate or should be recommended to dub in a dialect rather than a standard language variety that represents the target culture is a matter that needs investigation from a linguistic (translational) rather than sociolinguistic point of view.

The Mainland and Hong Kong

Hong Kong is a major source of English-to-Chinese subtitled audio-video products which are effectual in quality and quantity. As pointed out earlier, there is much to borrow from the Hong Kong experience for improving subtitling in the Mainland.

Subtitling has been used in Hong Kong as the way to translate foreign language film and TV programmes for the local audience. In fact, every movie is required by law to be subtitled either in English (for Chinese movies) or Chinese (for foreign movies). Cantonese dubbed movie versions are used only for the Bilingual (Laiyam) switching system for television viewers, but they are only occasionally available. Because of the different

systems for film importation, translation and distribution, Hong Kong and Mainland China have had their own practices and standards concerning film translations. It is not unusual to see in the audio-visual market that the same American movie has a Hong Kong subtitled version and a Mainland dubbed version, or even two different subtitled/dubbed versions from the two systems.

How Hong Kong and the Mainland should learn and benefit from each other in the field of film translation is a research-worthy topic never attended to. With closer contact and more frequent cultural exchanges between Hong Kong and the Mainland after the 97 Handover, will their different orientations, criteria and practices with respect to audio-visual products to some extent converge under the mutual influence of the two systems and in what possible ways? Will the increasing popularity of Mandarin in Hong Kong and English in the Mainland facilitate the change, with the audience preference becoming more subtitling-oriented (in the Mainland) or more dubbing-oriented (in Hong Kong), for instance? What, and to what extent, can they borrow from each other's successful experiences and technologies in film translation?

Answers to these and other questions regarding English-to-Chinese film translation may become more significant to researchers and professionals working in this field in both parts of China as the country becomes culturally more unified.

The Translator's Context

It has been pointed out in this study that, apart from the translator's communicative skills and the methodology employed, the quality of a film translation is also subject to the external factors affecting a translator's work, including the pressure from the translation initiator (if it is different from the translator), the consumer's special demands, the time and economic constraints on the translation task, etc. Based on two telling anecdotes⁷ and other empirical observations, this seems to be a topic of particular significance in the Chinese context for further investigation.

In China, because of the intricacies of the administrative systems and relationships and other socio-economic factors in addition to the usual circumstantial ones, some have argued that the professional status of the film/TV translator is not up to the required standard. Such a view has

also been reflected in the consistent attitudes of some practitioners towards the value of their work, which has been regarded as inferior and unimportant.

This observation, in view of its significance to film translation studies in China in general and to the practicality of the acceptance of the FITNIATS model by Chinese film translators in particular, deserves an extensive survey to verify. In analyzing an audio-visual translation, the translator's constraints must be taken into full consideration to isolate the individual case and incidental instances from the general level and trend of practice, so that the assessment of translation quality can be more objectively informative. As a matter of fact, investigating the translation's own context in general is a valuable research topic needing to be looked into.

7.4 Looking Into the Future: The 'Titanic' Phenomenon

James Cameron's blockbuster Titanic has been the greatest hit in Chinese box-office history. "Dubbed and uncensored"⁸, it started showing in China on April 2nd, 1998, lagging behind Hong Kong by three and a half months, but still quite timely

in the lingering of "the-Oscar-goes-to..." excitement over this big winner. The *Titanic* fever heat reached every Chinese city and beyond, breaking box-office records one after another.

In Beijing, 3rd April, the first day of *Titanic*, 16 city cinemas sold out the tickets totalling 1.06 million yuan (US\$ 127,711), breaking the single-film daily box-office record in the region⁹. The film nearly tripled the record for the 'hottest' Chinese film and made about 2.5 million US dollars by the end of the 20 days of its run in the capital¹⁰. In Eastern China, unprecedentedly, the first day matinees of the film were exclusively 'full house' throughout Shanghai, a city more famous for its night life¹¹. Shanghai's two biggest cinemas said that the day-time showings were 90-95 percent sold out, even though the tickets were selling for 35-50 yuan (US\$4.2-6), fairly high considering an urban person's average monthly income which is only 700 yuan (US\$84)¹². In the Southern city Guangzhou, the *Titanic* storm also swept across the whole metropolis. The launch of the premiere on the 2nd April received from ticket sales more than 500,000 yuan (US\$ 60,241) for the day. The first week (up to April 9th) box-office sum exceeded 4.8 million yuan (US\$ 578,313). "More

than 2 million yuan from the first five days alone, it was absolutely the record high in the history of Guangzhou cinema"¹³.

A remarkable cinematic event in China, *Titanic* became 'the talk of the town' everywhere in the country. In Guangzhou, people turned out in such a frenzied manner that public lectures, seminars, debates, radio phone-ins, TV quizshows and even package tours (for those living in the neighbouring country areas), were literally in full swing, not to mention the ever-crawling ticket queues, the make-shift seats and standing room added into cinemas, as well as a profusion of placards and posters (8 different varieties from the government film distributors alone) - all because of *Titanic*¹⁴.

The *Titanic* wave in China went beyond the craze for Hollywood megamovies. From behind this social phenomenon, too much pabulum was left undigested. What seems to be more relevant here is the revelations this event made to film translation researchers.

(1) Being one of the elite American movies for general release in China, *Titanic* has picturesquely disclosed the big sale potential of this world movie market, which is too

massive for only ten new 'megahits' a year. More importations of choice foreign films are inevitable and so are greater demands for quality film translations.

(2) That dubbing is undoubtedly the preferred form for translating foreign language films to the great majority of Chinese viewers was confirmed by the unanimous choice made for viewing this movie. The movie's video compact discs, usually videotaped in cinemas during showtime in places like Hong Kong, had been in easy access on the mainland even several months before the dubbed *Titanic* movie was released. To own a VCD copy of the movie cost only about 75% of the price of a ticket for the cinema dubbed version. The main reason for the unsubdued number and exuberance of the cinema-goers is apparently one of dubbing over subtitling, as the following three news reports reveal (the emphasis is mine):

- The movie's pirated VCD... has been widely available for over a month at a price of 30 Yuan (US\$3.6), **but it is in English with Chinese subtitles.** (CND, 04/02/98)
- The VCD of the film is sold at 30 yuan a set, cheaper than a ticket for the movie, which is 35-50 yuan; but according to the *Titanic* fans, the cinema version is not only much clearer but also it is dubbed in Chinese. (My translation; News of the Week, in *Hua Xia Wen Zhai*, No. 366, April 3rd 1998, cm9804a)

- There are at least three versions of Titanic showing at all cinemas in Guangzhou: the subtitled SDDS version and two dubbed versions, one in SR stereo sound and the other in SRD digital sound. ... They each show their pros and cons. The SDDS version keeps the original flavour, but forces the eyes to follow the subtitles so that the pictures are sometimes overlooked for chasing the words. The dubbed versions can make up for this disadvantage to enable the audience to concentrate on the details of the performance. (My translation; Guangzhou Daily, 10 April 1998)

According to the results of a questionnaire survey of Beijing's cinemas (medium-sized-or-above), over 85% of the subjects are in the opinion that the affordable ticket price for a dubbed imported movie should be 50% less of the current normal price (20-30 yuan), which is usually two to three times that of a domestically-made film¹⁵. However, the ticket for the dubbed *Titanic* priced well beyond the upper limit and sold well, in spite of the availability of the cheaper subtitled VCD versions shown concurrently in privately-owned cinemas in the Chinese major cities.

- (3) The dubbed *Titanic* produced by the Shanghai Film Dubbing Studio is generally acclaimed as a huge success. But criticisms of the mismatches found in the dubbed dialogue of *Titanic* in comparison with the original by earnest or nit-picking critics from among the

English-enlightened audiences are just as unsparing as the praises for the translation. Whether the remarks about Jack's language being made "overrefined" for a vagrant boy, the Chinese Rose sounding a bit "too affectionate", or the humour of her centenarian version (in "[How extraordinary! Still the same mirror;] the reflection has changed a bit though") being unforgivably ruined in translation, etc., etc.¹⁶, reflect the audiences' heightened awareness of the translation quality and existing problems in dubbing which are worth further investigation.

- (4) On the other hand, subtitling has become the favoured choice by more and more foreign film goers who are better-educated and mostly English-learning enthusiasts in big cities. According to a survey on the dub-sub preference among Shanghai audiences in the wake of Titanic tour in the city¹⁷, 67.34% of the audience prefer subtitling; 48.66% find dubbed versions enjoyable. In the literateness dimension, 60.22% of those who have received tertiary education are fond of the subtitling mode, whereas those who insist on dubbing being unquestionably the more desirable have a schooling at secondary or lower levels, which take up 53.48% of the audience number total. The survey highlights two major factors contributing to this new trend: (a) English has been playing an increasingly important role in the daily life of Shanghai people as this China's largest city is developing into a new-century metropolis by leaps and bounds. To watch a

subtitled movie, more and more people take it as a good learning opportunity for improving their spoken English as well as for entertainment; (b) With subtitled films on VCDs entering into more and more families, people's traditional viewing habits are undergoing change. More and more people are used to reading subtitles to understand a foreign language movie while benefiting from having the original soundtrack.

The survey predicts that the percentage of the audience preference for subtitling will increase with the upgrading of the individual's self-cultivation of literary/artistic taste and the quality of the city's cultural life in general. The *Titanic* case is cited as part of the supporting evidence of this trend. Throughout its first run in the city, the only two cinemas showing the subtitled versions of the movie were unceasingly overcrowded, making the highest box-office record ever of all city cinemas. The survey concludes that there is an irreversible pro-subtitling current in the changing cultural life of the Shanghai people. Or may it also be that of the people elsewhere in the country?†

Chapter 7

NOTES

1. Predictably, these criteria will be rationalized and internationalized in the foreseeable future in the PRC.

2. In the course of this research project, I carried out a series of informal audience survey on a small but extensive scale to elicit their reactions to and comments on the research data. These investigations took place immediately after the viewing of selected episodes from FDt1 and my vocalized demonstrations of FDt2 as an alternative translation in comparison with FDt1. As the results of this study would lead us to expect, FDt1 was unanimously regarded as unnatural in style and dubious in fidelity; in contrast, FDt2 was unhesitatingly acclaimed to be superior to FDt1 even if in its pre-dubbing form.

3. *Oprah: Interviewing Robin Williams and Matt Damon* about the Megahit *Good Will Hunting* (1997), NBC Television, February 1998.

4. Walter Hoylman: email to Jian Li, 25th July, 1996.

5. See "Qicai Kuaiyu" Section of *Yangcheng Wanbao* (Ram-city Evening) newspaper between April 9th, 1994 and May 17th, 1994.

6. For details see Davies 1992:192-206.

7. This refers to totally different reactions I received from a dubbing/subtitling translator of the Guangdong Television and a subtitler of the SBS Television to the same subject I initiated in conversations with them in China and Australia respectively. Both of them were a full-time senior film translators whom I was meeting for the first time.

(Having explained the same topic in film dialogue translation I would research into)

GDTV translator(05/94):

What's the point of doing such a study!?

SBS subtitler (02/96):

Hope you'll be lenient to us.

Their different attitudes reveal different degrees of sense of responsibility for their work. One of the known reasons is that a SBS subtitler is in control of the whole translation process, whereas the GDTV translator's work had been subject to unexpected censorship, or wanton changes by other people including the dubbing director and the actors as well as those in charge of the staff and production.

8. As reported by CND (China News Digest), April 2, 1998, in *Global News*, No. GL98-049, <http://www.cnd.org/>

9. See *China's Scholars Abroad* (electronic edition), No. 170, April 17, 1998, <http://www.chisa.edu.cn/>

10. According to the Beijing United Film Company, the film's local distributor. (CND, 04/21/98).

11. Reported by *Hua Xia Wen Zhai* (cm9804a), No. 366, <http://www.cnd.org/HXWZ/>

12. Reported by CND, 04/02/98.

13. From *Guangzhou Daily*, April 10, 1998.

14. Ibid.

15. See *Guangzhou Daily*, Feb. 24, 1998, reported by Li Hua from Beijing.

16. Information from the email exchanges with YAN Jie, a journalist of *Nanfang Zhoumo* (Weekend in South China) newspaper supplement, between 3rd - 30th April, 1998.

17. See '*Entertainment News*', *Guangzhou Daily*, June 11, 1998.

REFERENCES

- Armer, A. A. 1993. *Writing the Screenplay: TV and Film*. Wadsworth Publishing Company: California.
- Arnaiz, C. 1996. "Film Translation and the Cultural Space". In *Proceedings of XIVth World Congress of the FIT (Feb. 1996)*, pp. 432-440.
- Arnáiz, C. 1996. "Film Translation and the Cultural Space". In *Proceedings of the 14th FIT World Congress, Melbourne Feb. 1996*. AUSIT: Melbourne. pp. 432-440.
- As-Safi, A. & Ash-Sharifi, I. S. 1997. Naturalness in Literary Translation. *Babel*, 43 (1), 60-75.
- Baker, Mona 1992. *In Other Words: A coursebook on translation*. Routledge: London and New York.
- Barbe, K. 1996. Dubbing in the Translation Classroom. *Perspective: Studies in Translatology*, 4 (2), 274.
- Barkhudarov, L. 1993. "The Problem of the Unit of Translation". In Zlateva, P. (Ed.) *Translation as Social Action*. Routledge: London & New York. pp39-46.
- Bassnett, S. 1991. *Translation Studies*. Routledge: London.
- Bell, R. T. 1991. *Translation and Translating: Theory and Practice*. Longman: London & New York.
- Benjamin, W. 1979. "The task of the translator". In Arendt, H. (Ed.) *Illustrations*. Foutana:London. pp. 76 - 89.
- Bennett, P. 1996. The translation unit in human and machine. *Babel*, 40 (1), 12-20.
- Bishop, R. 1988. "There's nothing natural about natural conversation: a look at dialogue in fiction and drama". In Jurak, M. (Ed.) *Cross-cultural Studies: American, Canadian and European Literature 1945-1985*. Ljubljana. pp. 257-265.
- Blacker, I. R. 1986. *The Elements of Screenwriting: A guide for film and television writers*. MacMillan Publishing Company/Collier MacMillan Publishers: New York/London.
- Bolinger, D. 1986. *Intonation and Its Parts: Melody in Spoken English*. Stanford University Press: California.

- Bolinger, D. 1989. *Intonation and Its Uses: Melody in Grammar and Discourse*. Stanford University Press: California.
- Bolton, K. & Kwok, H. (Ed.) 1992. *Sociolinguistics Today: International Perspectives*. Routledge: London/New York.
- Brandle, M. 1997. "The Quest for Language Equivalence Through TV Subtitles". In *Proceedings of XIVth World Congress of the FIT (Feb. 1996)*. pp. 966-977.
- Brazil, D. 1985. *The Communicative Value of Intonation*. (Monograph No. 8), University of Birmingham: Birmingham.
- Brazil, D. 1995. *A Grammar of Speech*. Oxford University Press: Oxford.
- Brondeel, H. 1994. Teaching subtitling routines. *Meta*, xxxix (1), 27-33.
- Budick, S. & Iser, W. (Eds.) 1996. *The Translatability of Cultures: Figurations of the Space Between*. Stanford University Press: Stanford.
- Burton, D. 1980. *Dialogue and Discourse: A Sociolinguistic Approach to Modern Drama Dialogue and Naturally Occurring Conversation*. Routledge & Kegan Paul: London.
- Catford, J. C. 1965. *A Linguistic Theory of Translation*. Blackwell: Oxford.
- Catford, J. C. 1994. "Translation: Overview". In: Asher, R. E. (Ed.) *The Encyclopaedia of Language and Linguistics*. pp. 4738-4747.
- Cattrysse, P. 1992. Film (Adaptation) as Translation: Some Methodological Proposals. *Target*, 4 (1), 53-70.
- Cattrysse, P. 1998. "Translation in the New Media Age: Implication for Research and Training". In Gambier, Y. (Ed.) *Translaing for the Media*. Stjerome:Turku. pp. 7-12.
- Chafe, W. 1982. "Integration and Involvement in Speaking, Writing and Oral Literature". In Tannen, D. (Ed.) *Spoken and Written Language: Exploring Orality and Literacy*. ALEX: New Jersey.
- Chafe, W. 1987. "Cognitive constraints on information flow". In: R. S. Tomlin (Ed.) *Coherence and Grounding in Discourse*. John Benjamins:Amsterdam. pp. 21-51.
- Chafe, W. 1988. Punctuation and the prosody of written language. *Written Communication*, 5 (4), 395-426.

- Chafe, W. 1992a. "Information flow in speaking and writing". In P. Downing et al (Ed.) *The Linguistics of Literacy*. John Benjamins:Amsterdam. pp.17-29.
- Chafe, W. 1992b. "The flow of ideas in a sample of written language". In W. C. Mann and Thompson, S. A.(Eds) *Discourse Description: Diverse Linguistic Analyses of a Fund-raising Text*. John Benjamins:Amsterdam. pp. 267-294.
- Chafe, W. 1993. "Prosodic and functional units of language". In: J. A. Edwards and Lampert, M. D. (Eds) *Talking Data: Transcription and Coding in Discourse Research*. Erlbaum:Hillsdale, NJ. pp. 33-43.
- Chafe, W. 1994. *Discourse, Consciousness, and Time: The Flow in. Displacement of Conscious Experience in Speaking and Writing*. The University of Chicago Press:Chicago and London.
- Chalier, C. 1996. "If I Read You Well, You Promise Me the World: the Challenge of Subtitling for Australian TV Today". In: *Proceedings of XIVth World Congress of the FIT (Feb. 1996)*, pp. 441-447.
- Chang, N. F. 1996. Towards a better general theory of equivalent effect. *Babel*, 42 (1), 1-17.
- Che, Shi 1991. "Peiyinde Benxing (The Nature of Dubbing)". In: *Selected Papers of the Second National Conference on Work in Dubbing for Television, 4-10 Oct. 1991, Lanzhou*. Dubbing Section, Guangdong TV. Unpublished.: Guangzhou. pp. 29-37.
- Chen, C. 1980. *Dependent Clauses in Mandarin Chinese*. PhD. Thesis UMI Dissertation Services.
- Chen, Jianmin 1984. *Haiyu Kouyu (Spoken Chinese)*. Beijing Publishing House: Beijing.
- Chen, Jianmin 1986. *Xiandai Hanyu Juxing Lun (On Modern Chinese Sentence Patterns)*. Yuwen (Language) Press: Beijing.
- Chen H. & Tzeng, O. (Eds.) 1992. *Language Processing in Chinese*. Advances in Psychology 90. North-Holland: Amsterdam/London/New York.
- Cmejrkova, S. et al (Eds.) 1994. *Writing vs Speaking: Language, text, discourse, communication*. Proceedings of the conference held at the CLIAS of the Czech Republic, Prague, Oct. 14-16, 1992GNV: Tubingen.
- Cook, G. 1992. *The Discourse of Advertising*. Routledge: London/New York.
- Coulmas, F. (Ed.) 1981. *Conversational Routine: Explorations in Standardized communication Situations and Prepatterned Speech*. Mouton: The Hague.

- Coulthard, M. 1977. *An Introduction to Discourse Analysis*. Longman: London.
- Coulthard, M. 1992. *Advances in Spoken Discourse Analysis*. Routledge: London.
- Crampton, P. 1989. "The spoken word". In C. Picken (Ed.) *The Translator's Handbook*. Aslib:London. pp.118-119.
- Crystal, D. 1969. *Prosodic systems and Intonation in English*. Cambridge University Press: London.
- Crystal, D. 1975. *The English Tone of Voice*. Edward Arnold: London.
- Custen, G.F. 1982. "Talking about film". In S.Thomas (Ed.) *Film/Culture: Explorations of Cinema in its Social Context*. ABLEX:New Jersey. pp. 237-246.
- de Linde, Zoe 1995. 'Read my lips': Subtitling principles, practices, and problems. *Perspectives: Studies in Translatology*, 1, 9-20.
- Danan, M. 1991. Dubbing as an expression of nationalism. *META: Translators' Journal*, 36 (4), 606-614.
- Davies, M. 1994. "Intonation IS visible in written English". In Cmejrkova, S. et al (Eds.) (1994) . pp. 199-203.
- Davies, P. 1992. "The non-Beijing dialect component in Modern Standard Chinese". In: Bolton, K. & Kwok, H. (Eds.) *Sociolinguistics Today: International Perspectives*. Routledge: London & New York. pp.192-206.
- Dean, Richard 1987. The Subs and Dubs Divide. *TV World*, June/July 1987, X (5), 38-39.
- Delabastita, D. 1989. Translation and mass-communication: film and T.V. translation as evidence of cultural dynamics. *BABEL*, 35 (4), 193-218.
- Delabastita, D. 1990. "Translation and Mass Media". In: Bassnett, S. & Lefevere, A. (Eds.) *Translation, History and Culture*. Pinter:London. pp. 97-109.
- Delabastita, D. 1995. "Translation and Mass Communication". In Chan, S. & Pollard, D. E. (Eds.) *Encyclopedia of Translation*. The Chinese University Press:Hong Kong.
- Devereaux, M. 1986. Of "Talk and Brown Furniture": the aesthetics of film dialogue. *Post Script: Essays in Film and the Humanities*, 6 (1), 32-52.

- Dijk, T.A. van (Ed.) 1985a. *Handbook of Discourse Analysis*. 1 Academic: London.
- Dijk, T.A. van (Ed.) 1985b. *Handbook of Discourse Analysis*. 3 Academic: London.
- Dijk, T.A. van (Ed.) 1985c. *Discourse and Communication: New Approaches to the Analysis of Mass Media Discourse and Communication*. Walter de Gruyter: Berlin.
- Dirven, R. & Fried, V. (Eds.) 1987. *Functionalism in Linguistics*. LLSEE 20. John Benjamins: Amsterdam/ Philadelphia.
- Doherty, M. 1992. Relativity of sentence boundary. *Babel*, 38 (2), 72-78.
- Dopheide, T. 1996. "'Just an Illusion': A Review of Practical Problems in Dubbing American Movies". Article presented in the international conference *LANGUAGE & THE MEDIA*, Berlin Nov. 1996, (provided by the author).
- Doty, K. L. 1984. *Fiction Into Drama: A pragmatic analysis of dramatic dialogue in Adaptations*. PhD. Thesis UMI Dissertation Services.
- Downes, W. 1988. "Discourse and drama: King Lear's 'question' to his daughters". In W.van Peer (Ed.) *The Taming of the Text: Explorations in Language, Literature and Culture*. Routledge: London. pp. 225-257.
- Downing, J. (Ed.) 1987. *Film and Politics in the Third World*. Praeger: New York.
- Dries, J. 1994-95. Breaking Language Barriers Behind the Broken Wall (Voice-over, Dubbing or Subtitling?). *Intermedia*, XXII (6, December-January), 35-37.
- Dries, J. 1995. *Dubbing and Subtitling: Guidelines for Production and Distribution*. The European Institute for the Media: Düsseldorf.
- Duranti, A 1985. "Sociocultural dimensions of discourse". In T.A.van Dijk (Ed.) *Handbook of Discourse Analysis*. Vol. 1. Academic: London.
- El-Sakran, T. M. 1997. Subtitling versus dubbing: a Case Study of Egyptian TV programmes. *Translatio - FIT Newsletter*, XVI (1-2), 95-104.
- Elam, K. 1980. *The Semiotics of Theatre and Drama*. Methuen: London.
- Eustace, G. 1990. *Writing for Corporate Video*. Focal Press: London/Boston.
- EX: The Online World of Anime and Manga 1998. Subtitling Versus Dubbing. <http://www.ex.org/1.5/0.4-survey1.html>; [~1.5/0.5-survey2.html](http://www.ex.org/~1.5/0.5-survey2.html), 1 (5).
- Fan, X. 1991. *Hanyu de Duanyu (Chinese Phrases)*. The Commercial Press: Beijing.

- Fairclough, N. 1995. *Media Discourse*. Edward Arnold: New York.
- Fillmore, C. 1985. "Linguistics as a tool for discourse analysis". In T.A.van Dijk (Ed.) *Handbook of Discourse Analysis*. Academic: London. pp. 11-39.
- Firbas, J. 1992. *Functional Sentence Perspective in Written and Spoken Communication*. Cambridge University Press: New York.
- Fodor, I. 1976. *Film Dubbing: Phonetic, Semiotic, Esthetic and Psychological Aspects*. Helmut Buske: Hamburg.
- Fox, B. A. 1987. *Discourse Structure and Anaphora: Written and conversational English*. Cambridge University Press: Cambridge/New York.
- Fries, P. H. 1992. The Structuring of Information in Written English Text. *Language Sciences*, 14 (4), 461-488.
- Fronek, J. 1978. *Thematic Meaning and Translation: Functional sentence perspective and its relevance for contrastive language study*. PhD. Thesis The British Library .
- Gambier, Y. (Ed.) 1998. *Translating for the Media: Papers from the International Conference Languages & the Media*. Stjerome: Turku.
- Gambier, Yves 1994. "Audio-visual Communication: Typological Detour". In Dollerup, C. & Loddegaard, A. (Ed.) *Teaching Translation and Interpreting 2: Insights, aims, visions*. John Benjamins: Amsterdam/Philadelphia. pp. 275-283.
- Geist, K. 1991. English in non-English-language films. *World Englishes*, 10 (3), 263-274.
- Geluykens, R. 1994. "Interactional and topical coherence in conversation". In Cmejrkova et al (Eds.) *Writing vs Speaking: Language, text, discourse, communication*. GNV: Tübingen. pp. 251-258.
- Gentzler, E. 1993. *Contemporary Translation Theories*. Routledge: London & New York.
- Givon, T. (Ed.) 1997. *Conversation: Cognitive, Communicative and Social Perspectives*. John Benjamins: London/New York.
- Golomstock, Igor 1990. *Totalitarian Art: in the Soviet Union, the Third Reich, Fascist Italy and the People's Republic of China*. Collins Harvill: London.

- Gostand, R. 1980. "Verbal and non-verbal communication: drama as translation". In O. Zuber (Ed.) *The Languages of Theatre: Problems in the Translation and Transposition of Drama*. Pergamon: Oxford.
- Gottlieb, H. 1992. "Subtitling - A New University Discipline". In Dollerup, C. & Loddegaard, A. (Ed.) *Teaching Translation and Interpretation: Training, talent, and experience*. John Benjamins: Amsterdam/Philadelphia. pp. 161-170.
- Gottlieb, H. 1994a. "Subtitling: People Translating People". In Dollerup, C. & Loddegaard, A. (Ed.) *Teaching Translation and Interpreting 2: Insights, aims, visions*. John Benjamins: Amsterdam/Philadelphia. pp. 261-274.
- Gottlieb, H. 1994b. Subtitling: Diagonal Translation. *Perspectives: Studies in Translatology*, 2 (1), 101-121.
- Gottlieb, H. 1995. "Subtitling". In Chan, S. & Pollard, D. E. (Eds.) *Encyclopedia of Translation*. The Chinese University Press: Hong Kong.
- Grace, G. W. 1987. *The Linguistic Construction of Reality*. CROOM HELM: London/New York/Sydney.
- Grillo, V. & Kawin, B. 1981. Reading at the movies: subtitles, silence, and the structure of the brain. *Post Script*, 1 (1), 25-32.
- Gutt, E.- A. 1991. *Translation and Relevance: Cognition and context*. Basil Blackwell: Oxford/Cambridge.
- Halliday, M. A. K. 1964. "Syntax and the consumer". In *Georgetown Monograph Series on Language and Linguistics 17*. Georgetown University Press: Washington. pp. 189-206.
- Halliday, M. A. K. 1966. "Descriptive linguistics in literary studies". In McIntosh, A. & Halliday, M.A.K. (Eds.) *Patterns of Language: Papers in General, Descriptive and Applied Linguistics*. Longman, Green and Co. LTD: London. pp. 56-69.
- Halliday, M. A. K. 1970. *A Course in Spoken English: Intonation*. Oxford University Press: London.
- Halliday, M. A. K. 1994. *An Introduction to Functional Grammar*. Edward Arnold: London.
- Hartmann, R.R.K. 1980. *Contrastive Textology: Comparative Discourse Analysis in Applied Linguistics*. Groos: Heidelberg.

- Hartmann, R.R.K. 1981. Contrastive textology, applied linguistics and translation. *Poetics Today*, 2 (4), 111-120.
- Hass , W. 1970. *Phono-graphic Translation*. Manchester University Press: Manchester.
- Hatim, B. 1984. A text typological approach to syllabus design in translating. *Incorporated Linguist*, 23 (3), 146-49.
- Hatim, B. 1996. "Text world in transition: orality and text structure in translation". In *ALAA '96 Conference Proceedings*.
- Hatim, B. & Mason, I. 1990. *Discourse and the Translator*. Longman: London.
- Hatim, B. & Mason, I. 1997. *The Translator as Communicator*. Routledge: London & New York.
- Hattori, S. et al (Eds.) 1990. *Proceedings of the 8th International Congress of Linguists, Aug. 29 - Sep. 4, 1982*. Tokyo: Tokyo Press.
- Hayward, S. 1984. Prolegomena II: an application of discourse analysis to filmic language. *Language and Style: an International Journal*, 17 (4), 275-285.
- Heath, Stephen & Mellencamp, P. (Eds.) 1983. *Cinema and Language*. University Publications of America, Inc.: California.
- Herbst, T. 1987. A pragmatic translation approach to dubbing. *EBU Review*, 38 (6), 21-23.
- Herbst, T. 1991. "A plot-oriented nucleus-lip-sync governed translation approach to dubbing". In G. M. Luyken et al (Eds.) *Overcoming Language Barriers in Television*. European Institute for the Media: Manchester. pp. 158-165.
- Herbst, T. 1995. People Do Not Talk in Sentences: Dubbing and the idiom principle. *Translatio (FIT Newsletter)*, XIV (1995) (3-4), 257-271.
- Hervey, S. & Higgins, I. 1992. *Thinking Translation: A Course in Translation Method: French-English*. Routledge: London and New York.
- Hess-Luttich, E. W. B. 1985. "Dramatic discourse". In T. A. van Dijk (Ed.) *Discourse and Literature*. John Benjamins Publishing Company: Amsterdam. pp. 199-214.
- Hoffer, Bates L. 1984. "Cross-Cultural Sociolinguistic Profiles Misreadings and Misunderstandings". In Hattori S. & Inoue K. (Ed) *Proceedings of the 13th*

International Congress of Linguists. The Proceeding Publishing Committee of the 13th ICL: Tokyo. pp. 801-804.

House, J. 1981. *A Model for Translation Quality Assessment*. GNV: Tubingen.

House, J. & Blum-Kulka, S. (Ed.) 1986. *Interlingual and Intercultural Communication: Discourse and Cognition in Translation and Second Language Acquisition Studies*. GNVT: Germany.

Howkins, J. 1982. *Mass Communication in China*. Longman: New York.

Hymes, D. 1968. "The ethnography of speaking". In J.A. Fishman (Ed.) *Readings in Sociology of Language*. Mouton: The Hague. pp. 99-138.

Hymes, D. 1974. *Foundations in Sociolinguistics: An Ethnographic Approach*. UPP: Philadelphia.

Hymes, D. 1986. "Models of the interaction of language and social life". In J. Gumperz & D. Hymes *Directions in Sociolinguistics: The Ethnography of Communication*. Basil Blackwell: Oxford. pp. 35-71.

Ivarsson, Jan 1992. *Subtitling for the Medi: A Handbook of an Art*. Transedit: Stockholm.

Jame, H. 1998. "Screen Translation Training and European Co-operation". In Gambier, Y. (Ed.) 1998. pp. 243-258.

James, C. 1989. Genre analysis and the translator. *Target: International Journal of Translation Studies*, 1 (1), 29-41.

James H. & Roffe, I. & Thorne, D. 1996. "Screen Translation at University of Wales, Lampeter: the Case for a European Perspective". In Dollerup, C. & Appel, V. (Eds.) *Teaching Translation and Interpreting 3: New horizons*. John Benjamins: Amsterdam/Philadelphia.

Jin, D. 1989. *Dengxiao Fanyi Tansuo (In Search of Equivalent Effect Translating)*. China Translation & Publishing Corporation: Beijing.

Jin, D. & Nida, E.A. 1984. *On Translation: With special reference to Chinese and English*. China Translation & Publishing Corporation: Beijing.

Johnston, D. (Ed.) 1996. *Stages of Translation: Essays and interviews for the stage*. Absolute Classics: Scarborough, England.

Kachru, Y. 1992. Speech acts in the other tongue: an integrated approach to cross-cultural research. *World Englishes*, 11 (2/3), 235-240.

- Karamitroglou, Fotios 1998. A Proposed Set of Subtitling Standards in Europe. *Translation Journal*, 2 (April) (2).
- Kelly, L. G. 1979. *The True Interpreter: A History of Translation*. Basil Blackwell: Oxford.
- Key, M.R. (Ed.) 1980. *The Relationship of Verbal and Nonverbal Communication*. Mouton: The Hague.
- Kilborn, R. 1989. 'They don't speak proper English': a new look at the dubbing and subtitling debate. *Journal of Multilingual and Multicultural Development*, 10 (5), 421-434.
- Kilborn, R. 1992. *Television Soaps*. Batsford: London.
- Klammer, T. 1971. *The Structure of Dialogue Paragraph in Written English Dramatic and Narrative Discourse*. PhD. Dissertation University of Michigan: .
- Klerkx, J. 1998. "The Place of Subtitling in a Translator Training Course". In Gambire, Y. (Ed.) 1998. pp. 259-264.
- Kovacic, I. 1992. *A Linguistic Approach to Subtitling Television Programs*. PhD. Dissertation Abstract University of Ljubljana: Ljubljana.
- Kovacic, I. 1994. "Relevance as a Factor in Subtitling Reductions". In Dollerup, C. & Loddegaard, A. (Ed.) *Teaching Translation and Interpreting 2: Insights, aims, visions*. John Benjamins: Amsterdam/Philadelphia. pp. 245-251.
- Kovacic, I. 1995. Reception of subtitles: The non-existent ideal viewer. *Translatio (FIT Newsletter)*, XIV (1995) (3-4), 376-383.
- Kovacic, I. 1996a. "Six Subtitlers - Six Subtitling Texts". In *Paper presented at Dublin conference on screen translation, 9 - 11 May 1996*. Personal provision.
- Kovacic, I. 1996b. "Teaching Translation: Reinforcing Norms or Changing Them? The Case of Subtitling". In Dollerup, C. & Appel, V. (Eds.) *Teaching Translation and Interpreting 3: New horizons*. John Benjamins: Amsterdam/Philadelphia.
- Kovacic, I. 1996c. "Subtitling strategies: a flexible hierarchy of priorities". In Bosinelli, R. M. B. & Heiss, C. *Multimedia Translation for Film, TV and the Stage*. CLUEB: Bologna.

- Kovacic, I. 1998. "Language in the Media - A New Challenge for Translator Trainers". In Gambier, Y. (Ed.) 1998. pp. 123-129.
- Leech, G. & Short, M. 1981. *Style in Fiction*. Longman: London.
- Levinson, S. C. 1983. *Pragmatics*. Cambridge University Press: Cambridge.
- Li, J. 1987. *Film Dialogue: From a Linguistic Point of View*. MA thesis. Unpublished. GIFL: Guangzhou.
- Li, L. 1986. *Xiandai Hanyu Juxing (Modern Chinese Sentence Patterns)*. Commercial Press: Beijing.
- Li, Zhen 1992. Yizhipian Sandu Chuangzuode Xingzhi he Fangfa (The Nature and Methodology of the Third Creation: the Case of Dubbing). *Dianying Yishu (The Art of Cinema)*, 3, 51-57, 92. (In Chinese).
- Liang, T. 1993. *Zero Anaphora in Chinese: Cognitive strategies in discourse*. PhD. Thesis UMI Dissertation Services.
- Liu, Siliang 1993. Speech at the First Congress of the China Association of Radio Broadcasting, Film and Television and the Third National Conference on Work in Dubbing for TV. 14-21 June 1993, Nanjing.
- Lull, J. v. *China Turned On: Television, Reform, and Resistance*. Routledge: London.
- Luyken, G.-M. et al. 1991. *Overcoming Language Barriers in Television.: Dubbing and Subtitling for the European Audience*. EIM: Manchester.
- Lyons, J. 1995. *Linguistic Semantics: An Introduction*. Cambridge University Press: New York.
- Machefer, Daniele 1987. *Deux Aspects de la Traduction au Cinema*. Universite de Lille III.
- Mackerras, C. 1981. *The Performing Arts in Contemporary China*. Routledge & Kegan Paul: London.
- Mackerras, C. & Wichmann, E. (Eds.) 1983. *Chinese Theatre: From its Origins to the Present Day*. U. of Hawaii Press: Honolulu.
- Major, W. 1996. Hollywood's New Orientation. *BOXOFFICE magazine (electronic edition)*, (Feb. 2), <http://www.boxoff.com/index.html> .
- Malcolm, I. 1979. The west Australian Aboriginal child and classroom interaction: a sociolinguistic approach. *Journal of Pragmatics*, 3, 305-320.

- Malcolm, I. 1982. Speech events of the Aboriginal classroom. *Intl. J. Soc. Lang*, 36, 115-134.
- Malcolm, I. 1991. "The relevance of the ethnography of communication to the language teacher". In I. Malcolm (Ed.) *Linguistics in the Service of Society: Essays in Honour of Susan Kaldor*. ECU: Perth. pp. 171-190.
- Malmkjaer, K. 1993. Underpinning Translation Theory. *Target*, 5 (2), 133-148.
- Mason, I. 1994. "Dubbing and subtitling, film and television". In R. E. Asher (Ed.) *The Encyclopaedia of Language and Linguistics*. pp. 1066-1069.
- Mateo, M. 1995. Constraints and Possibilities of Performance Elements in Drama Translation. *Perspectives: Studies in Translatology*, 1, 21-33.
- McConnell-Duff, Alan. 1989. "A foreign country: on the translation of stage plays". In H. Coleman (Ed.) *Working with Language: a Multidisciplinary Consideration of Language Use in Work Contexts*. Mouton de Gruyter: Berlin. pp. 231-260.
- McDougall, B.S. (Ed.) 1984. *Popular Chinese Literature and Performing Arts in the People's Republic of China, 1949-1979*. U. of California Press: Berkeley.
- McGinnis, S. G. 1990. *A Pragmatic Analysis of Mandarin Interrogatives : Data from modern Taiwan drama*. PhD Thesis UMI Dissertation Services: .
- Melrose, S. 1994. *A Semiotics of the Dramatic Text*. Macmillan: London.
- Miller, J. E. 1994. "Speech and Writing". In Asher, R. E. (Ed.) *The Encyclopaedia of Language and Linguistics*. pp. 4310 - 4306.
- Miller, P.P. 1990. *Script Supervision and Film Continuity*. Focal Press: Boston.
- Minchinton, J. 1987. Fitting Titles: The subtitler's Art and the thread of Euro titles. *Sight and Sound: International Film Quarterly, Autumn 1987*, 56 (4), 279-282.
- Minchinton, J. 1992. "Dubbing, sub-titling and voice-overs". In C. Picken (Ed.) *ITI Conference 6 Proceedings*. ASLIB: London. pp. 89-96.
- Mohanty, N. 1996. Intranslatability and the translator's task. *Perspectives: Studies in Translatology*, 4 (2), 163-171.
- Moskowitz, K. 1979. Subtitles vs. dubbing: Debate goes on. *Take One (Toronto)*, 7 (5 , April 15.), 58.

- Negergaard-Larsen, Birgit 1993. Culture-bound Problems in Subtitling. *Perspectives: Studies in Translatology*, 2, 207-241.
- Newman, A. 1980. *Mapping Translation Equivalence*. ACCO: Leuven, Belgium.
- Newmark, P 1981. *Approaches to Translation*. pergamon: Oxford.
- Newmark, P. 1988. *A Textbook of Translation*. Prentice Hall: London.
- Newmark, P. 1991. *About Translation*. Multilingual Matters Ltd: Clevedon.
- Nicholson, N. S. 1995. Translation and Interpretation. *Annual Review of Applied Linguistics*, 15, 42-62.
- Nida, E. 1964. *Toward a Science of Translating*. Brill: Leiden.
- Nida, E. 1986. "Sociolinguistics and translating". In J.A.Fishman et al (Eds.) *The Fergusonian Impact: In Honor of Charles A. Ferguson on the Occasion of His 65th Birthday*. Mouton de gruyter: Berlin. pp. 471-477.
- Nida, E. & Taber, C.R. 1974. *The Theory and Practice of Translation*. Brill: Leiden.
- Norby, K. A. (Translated by Monica Scheer) 1998. Translator — a Lovely Profession. *Translation Journal*, 2 (Oct) (4), .
- Ochs, E. 1979. "Planned and Unplanned Discourse". In Givon, T. *Discourse and Syntax*. Academic Press: New York.
- Palmer, R.B.(Ed.) 1989. *The Cinematic Text: Method and Approaches*. AMS: New York.
- Papadakis, I. 1998. "Greece, a Subtitling Country". In Gambier, Y. (Ed.) *Translating for the Media: Papers from the International Conference Language and the Media*. Turku. pp. 65-70.
- Papegaaij, B. & Schubert, K. (Eds.) 1988. *Text Coherence in Translation*. Foris Publications: Dordrecht/Providence.
- Paquin, R. 1998a. "Translating for the Audio-visual in a Bilingual Country: The Canadian Dubbing and Subtitling Experience". In Gambier, Y. (Ed.) *Translating for the Media*. Stjerome: Turku. pp. 71-76.
- Paquin, Robert 1998b. Translator, Adapter, Screenwriter:Translating for the audiovisual. *Tranalstion Journal*, 2 (July).

- Pauluzzi, F. 1983. "Subtitles vs. dubbing: The New York Times polemic 1960-66". In D. Radliff-Umstead (Ed.) *Holding the Vision: Essays on Film*. Kent State University: . pp. 131-137.
- Perkins, R. D. 1992. *Deixis, Grammar, and Culture*. John Benjamins: Amsterdam/Philadelphia.
- Piazza, R. 1987. *A Conversational Analysis of Theatrical Discourse : repair procedures as the expression of dramatic interaction*. PhD. Thesis UMI Dissertation Service.
- Picken, C. (Ed.) 1989. *The Translator's Handbook*. Aslib: London.
- Portnoy, K. 1991. *Screen Adaptation: A scriptwriting handbook*. Focal Press: Boston/London.
- Proceedings 1996. *XIVth World Congress of the FIT (February 1996)*. Vol. 1, AUSIT: Melbourne.
- Proceedings 1997. *XIVth World Congress of the FIT (February 1996)*. Vol. 2, AUSIT: Melbourne.
- Reeves, Geoffrey. 1993. *Communications and the "Third World"*. Routledge: London.
- Reid, H. 1978. "Sub-titling, the intelligent solution". In P.A. Horguelin (Ed.) *Translation, a Profession*. CTIC: Ottawa. pp. 420-428.
- Reid, H. 1987. The Semiotics of Subtitling, or Why don't you translate what it says?. *EBU Review*, (6), 28-30.
- Reid, H. 1990. "Literature in the screen: subtitle translation for public broadcasting". In B.Westerweel et al (Eds.) *Something Understood: Studies in Anglo-Dutch Literary Tradition*. : . pp. 97-107.
- Reid, H. 1991. "Linguistic problems associated with subtitling". In Luyken G-M. et al *Overcoming Language Barriers in Television*. European Institute for the Media: Manchester. pp. 156-158.
- Reiss, K. 1971. *Möglichkeiten und Grenzen der Übersetzungskritik*. Max Heuber: Munich.
- Reiss, K. 1976. *Texttyp und Übersetzungsmethode Der Operative Text*. Scriptor: Kronberg.
- Reiss, K. 1981. Type, kind and individuality of text. *Poetics Today*, 2 (4), 121-31.

- Reynolds, S. 1988. *The Assessment of Mentalite: An Ethnomethodological Analysis of Films in Cross-cultural Perspective*. PhD. dissertation UMI Dissertation Services.
- Roffe, I. & Thorne, D. 1994. "Transcultural language Transfer: Subtitling from a Minority Language". In Dollerup, C. & Loddegaard, A. (Ed.) *Teaching Translation and Interpreting 2: Insights, aims, visions*. John Benjamins: Amsterdam/Philadelphia. pp. 253-259.
- Rose, M.G. 1981. *Translation Spectrum: Essays in Theory and Practice*. State University of New York Press: Albany.
- Ruuskanen, D. D. K. 1996. The effect of pragmatic factors on the definition of equivalence in translation. *Language Sciences*, 18 (3-3), 883-895.
- Sager, J. C. 1989. "Quality and standards - the evaluation of translations". In Picken, C. (Ed.) *The Translator's Handbook*. Aslib: London. pp. Chapter 8.
- Samuelsson-Brown, G. 1995. *A Practical Guide for Translators*. Multilingual Matters Ltd.: Clevedon/Philadelphia/Adelaide.
- Saville-troike, M. 1989. *The Ethnography of Communication: An Introduction*. Basil Blackwell: Worcester.
- Scandura, G. L. 1993. "Film translation: a hybrid between translation and interpretation". In Picken, C. (Ed.) *Translation, the Vital Link. Proceedings of the XIII World Congress of FIT. Brighton, August 1993.* ITI: London. pp. 446-450.
- Scandura, G. 1996. "What Makes a Good Film Translator?". In *Proceedings of XIVth World Congress of the FIT (Feb. 1996)*. pp. 360-365.
- Schiffirin, D. 1994. *Approaches to Discourse*. Blackwell: Oxford UK & Cambridge USA.
- Schmid, H. & A. van Kesteren (Eds.) 1984. *Semiotics of Drama and Theatre*. John Benjamins Publishing Company: Amsterdam/Philadelphia.
- Scolnicov, H. & Holland, P. (Eds.) 1989. *he Play out of Context: Transferring Plays from Culture to Culture*. The University Press: Cambridge.
- Shadoian, J. 1981. Writing for the screen: some thoughts on dialogue. *Literature/Film Quarterly*, 13, 85-91.

- ShanghaiTV 1991. Ruhe Baozheng Yizhipiande Zhiliang (How to Control the Quality of a Dubbed Foreign Film). *a report presented at the Second National Conference on Dubbing for Television, Lanzhou 4-10 Oct. 1991.*
- Shlesinger, M. 1994. "Intonation in the Production and Perception of Simultaneous Interpretation". In Lambert, S. & Moser-Mercer, B. (Eds.) *Bridging the Gap: Empirical research in simultaneous interpretation*. John Benjamins Publishing Company: Amsterdam/Philadelphia. pp. 225-236.
- Short, M. 1989. "Discourse analysis and the analysis of drama". In Carter, R. & Simpson P. (Eds.) *Language, Discourse and Literature: An Introductory Reader in Discourse Stylistics*. Unwin Hyman: London. pp. 139-168.
- Short, M. 1991. Discourse analysis in stylistics and literature instruction. *Annual Review of Applied Linguistics*, 11, 181-195.
- Sinclair, J. 1991. *Corpus, Concordance, Collocation*. Oxford University Press: Oxford.
- Snell-Hornby, M. et al (Eds.) 1994. *Translation Studies: An Interdiscipline*. John Benjamins B. V.: Amsterdam.
- Snyder, A.Falkin. 1981. *Discourse Structure in Modern French Plays and Spontaneous Conversation*. PhD. dissertation Microfilm from U. of Melbourne.
- Sobchack, T. & Sobchack, V. 1987. *An Introduction to Film*. Little Brown and Company: Boston.
- Sperber, D. & Wilson, D. 1986. *Relevance: communication and cognition*. Blackwell: Oxford.
- Stapele, P.van. 1990. "The analysis of deixis as a basis for discourse analysis of dramatic texts". In Halliday, M.A.K. et al (Eds.) *Learning, Keeping and Using Language*. John Benjamins Publishing Company: Amsterdam/Philadelphia. pp. 333-348.
- Swain, D & Swain, J. 1988. *Film Scriptwriting: A practical manual*. Focal Press: Boston/London.
- Swales, J. 1990. *Genre Analysis: English in Academic and Research Settings*. :Cambridge University Press: Glasgow.
- Swerts, M. & Geluykens, R. 1994. Prosody as a Marker of Information Flow in Spoken Discourse. *Language and Speech*, 37 (1), 21-43.

- Tabakowska, E. 1993. *Cognitive Linguistics and the Poetics of Translation*. Gunter Narr: Tübingen.
- Tan, P.K.W. 1989. *A Stylistics of Drama: Stoppard's "Travesties" with Particular Reference to Parody*. PhD. dissertation Microfiche from British Library.
- Tannen, D. 1982. Oral and Literate Strategies in Spoken and Written Narrative. *Language*, 58 (1).
- Tannen, D. 1989. *Talking Voices : Repetition, dialogue and imagery in conversational discourse*. Cambridge University Press: Cambridge/New York/Sydney.
- Tannen, D. & Lakoff, R. 1994. "Conversational Strategy and Metastrategy in a Pragmatic Theory". In Tanne, D. (Ed.) *Discourse and Gender*. ALEX: New Jersey.
- Thomas, S. & Evans W. 1990. *Communication and Culture: Language, Performance, Technology, and Media*. ALEX: New Jersey.
- Titford, C. 1982. Sub-titling — constrained translation. *Lebende Sprachen*, 27 (3), 113-116.
- Toolan, M. J. 1990. *The Stylistics of Fiction: A literary-linguistic approach*. Routledge: London/New York.
- Toury, G. 1985. "A rationale for descriptive translation studies". In T. Hermans (Ed.) *he Manipulation of Literature: Studies in Literary Translation*. Croom Helm: London. pp. 16-41.
- Uwajah, M.K.C. 1994. The Case for a Performative Translatology. *Perspectives Studies in Translatology*, 2, 245-258.
- van den Broeck, R. 1986. "Contrastive Discourse Analysis as a Tool for the Interpretation of Shifts in Translated Texts". In House, J. & Blum-Kulka, S. (Eds.) *Interlingual and Intercultural Communication*. GNVT: Germany. pp. 37-47.
- Vallisaari, L. 1997. "Subtitling and Surtitling Opera". In *Proceedings of XIVth World Congress of the FIT (Feb. 1996)*. pp. 953-956.
- Venuti, L. 1992. *Rethinking Translation: Discourse, Subjectivity, Ideology*. Routledge: London.
- Viezzi, Maurizio 1992. The Translation of Film Sub-titles from English into Italian. *The Interpreters' Newsletter*, (4), 84-86.

- Viezzi, Maurizio 1993. Written Translation and Simultaneous Interpretation Compared and Contrasted: A Case Study. *The Interpreters' Newsletter*, (5), 94-100.
- Voge, H. 1977. The translation of films: sub-titling versus dubbing. *BABEL*, 23 (3), 120-125.
- Wadensjö, C. 1993. The double role of a dialogue interpreter. *Perspectives: Studies in Translatology*, 1, 105-121.
- Wang, Z. 1991. Linguistics and Translation. *Foreign Language Teaching and Research*, 88 (4), 38-43.
- Webster, D. 1981. Limitation to the application of discourse analysis to translation. *Notes on Translation*, (No. 85), 35-42.
- Wellwarth, G. 1981. "Special considerations in drama translation". In M. Rose (Ed.) *Translation Spectrum*. State University of New York Press: Albany. pp. 140-146.
- Widdowson, H.G. 1982. "Othello in person". In R. Carter (Ed.) *Language and Literature: An Introductory Reader in Stylistics*. George Allen & Unwin: London. pp. 41-53.
- Wu, G. 1996. "Infomational equivalence in translation - the use of focus marking devices in English-Chinese translation". In *Proceedings of XIVth World Congress of the FIT*. AUSIT: Melbourne. pp. 289-296.
- Wu, Shan 1991. "Qian Tan Yizhipiande Shengyin Zaoxing he Yuyan Yishu (Thoughts on the Voice Imaging and Language Art of a Dubbed Film)". In *Selected Papers of the Second National Conference on Work in Dubbing for Television, 4-10 Oct. 1991, Lanzhou*. Dubbing Section, Guangdong TV. Unpublished.: Guangzhou. pp. 38-45.
- Xizhen, Guangzheng (Ed.) 1992. *Yujing Yanjiu Lunwenji (Papers on Context)*. Beijing Language Institute Press: Beijing.
- Xu, G. 1987. "Code and translation in cross-cultural discourse: a study of some examples from Chinese and English". In L. E. Smith (Ed.) *Discourse Across Cultures: Strategies in World Englishes*. Prentice-Hall: New York. pp. 66-72.
- Yang, Xueyan 1989. Shilun Xiju zai Yuyan Wentixue zhongde Diwei (Introducing Drama as a Genre in Stylistics). *Journal of Shanghai Foreign Language Institute*, 59 (1), 67-71.

- Yang, Xueyan 1991. Huayu Fenxi yu Xiju Yuyan Wentixue (Conversation Analysis and Drama Stylistics). *Foreign Language Teaching and Research*, 86 (2), 17-22.
- Yiyun 1991. "Ba Yizhipian Yishu Tui xiang Xinde Gaodu (Elevate the Art of Dubbing to a New Height)". In Zhang, Junxiang et al (Eds.) *Forty Years of the Shanghai Cinema*. Xuelin Publishing House: Shanghai. pp. 85-89.
- Yokoyama, O. T. 1986. *Discourse and Word Order*. John Benjamins: Amsterdam/Philadelphia.
- Zabalbeascoa, P. 1994. Factors in dubbing television comedy. *Perspectives: Studies in Translatology*, 2 (1), 89-99.
- Zabalbeascoa, P. 1997. "Dubbing and the Nonverbal Dimension of Translation". In Poyatos, F. (Ed.) *Nonverbal Communication and Translation: New Perspectives and Challenges in Literature, Interpretation and the Media*. John Benjamins: Amsterdam/Philadelphia. pp. 327-342.
- Zaza, T. 1993. *Script Planning: Positioning and Developing Scripts for TV and Film*. Focal Press: Boston.
- Zhang, J. & C. Yunqing. 1981. *Yinghan Bijiaoyufa Gangyao*. Commercial Press: Beijing.
- Zhang, J. 1993. Translation Is Not a Science. *Chinese Translators Journal*, (3), 39-41.
- Zhang, Jin & Chen, Y. 1981. *Yinghan Bijiaoyufa Gangyao (An Outline of Comparative Studies of English and Chinese Grammars)*. Commercial Press: Beijing.
- Zhou, Chuanji 1988. "China Needs Professional Film Critics in Audiovisual Language". In *Film Studies: Proceedings of the First Annual Conference on Film Studies of the China Association of Film Critics, 1984, Beijing*. China Film Press: Beijing. pp. 429-452.
- Zhuang, M. 1991. Han-ying tongsheng chuanyi de jiqiao (Skills in Simultaneous Interpretation from Chinese into English). *Zhongguo Fanyi (Chinese Translators Journal)*, (2), 24-26.
- Zlateva, P. (Ed.) 1993. *Translation as Social Action*. Routledge: London & New York.
- Zuber-Skerritt, O. 1988. Towards a typology of literary translation: drama translation science. *META*, 33 (4), 485-490.

Zuber-Skerritt, O. (Ed.) 1984. *Page to Stage: Theatre as Translation*. Rodopi: Amsterdam.

Zuber, O. (Ed.) 1980a. *The Languages of Theatre: Problems in the Translation and Transposition of Drama*. Pergamon: Oxford.

Zuber, O. (Ed.) 1980b. "The translation of non-verbal signs in drama". In M.G.Rose (Ed.) *Translation: Agent of Communication*. Outrigger: Hamilton(NZ). pp. 61-74.

Zucker, R. 1966. In Defense of Dubbing. *Motion Picture Herald*, July 6, 5.