

N92-19748

Finite Difference Time Domain Calculation  
of Transients in  
Antennas with Nonlinear Loads

by

Raymond Luebbers, John Beggs, and Karl Kunz  
Department of Electrical and Computer Engineering  
The Pennsylvania State University  
University Park, PA 16802

and by

Kent Chamberlin  
Department of Electrical and Computer Engineering  
University of New Hampshire  
Durham, New Hampshire

July 1991

Abstract

Determining transient electromagnetic fields in antennas with nonlinear loads is a challenging problem. Typical methods used involve calculating frequency domain parameters at a large number of different frequencies, then applying Fourier transform methods plus nonlinear equation solution techniques. If the antenna is simple enough so that the open circuit time domain voltage can be determined independently of the effects of the nonlinear load on the antenna current (an infinitesimal dipole, for example), time stepping methods can be applied in a straightforward way. In this paper transient fields for antennas with more general geometries are calculated directly using Finite Difference Time Domain methods. In each FDTD cell which contains a nonlinear load, a nonlinear equation is solved at each time step. As a test case the transient current in a long dipole antenna with a nonlinear load excited by a pulsed plane wave is computed using this approach. The results agree well with both calculated and measured results previously published. The approach given here extends the applicability of the FDTD method to problems involving scattering from targets including nonlinear loads and materials, and to coupling between antennas containing nonlinear loads. It may also be extended to propagation through nonlinear materials.

## INTRODUCTION

Calculating the transient electromagnetic fields in antennas and scatterers containing nonlinear loads or material is a difficult problem. The traditional approach has been to apply frequency domain methods at a large number of harmonic frequencies. Sarkar and Weiner [1] used this approach in combination with a Volterra series analysis to determine scattering from antennas with nonlinear loads. Liu and Tesche [2,3] separated the problem into linear and nonlinear portions, calculated wideband frequency domain characteristics for the linear portion of the problem, transformed this to the time domain, and then solved the nonlinear portion by time marching. They achieved good agreement with measurements using this approach, and their results presented in [3] will be used to validate the results obtained in this paper. However, obtaining the frequency domain results for a complicated antenna at the large number of frequencies involved may be quite tedious and involve significant computer resources. And this approach cannot be extended to situations involving scattering from bulk regions of nonlinear materials, or to propagation through nonlinear materials as can the FDTD approach presented here.

For the simpler situation where the time domain open circuit voltage on the antenna terminals can be determined independently from the effects of the nonlinear load the frequency domain portion of the approach of Liu and Tesche can be dispensed with, and the open circuit voltage can be used as the input to a nonlinear circuit model of the load, with the resulting problem solved directly using time marching or other methods applied to nonlinear circuits. This approach was used by Kanda [4], who also gives an excellent review of previous work in this area.

Finally, Schuman [5] applied a time domain method of moments approach to a thin straight wire. However, his method appears difficult to apply to more general geometries.

In this paper the Finite Difference Time Domain (FDTD) approach will be extended to include nonlinear lumped loads. The

reader is assumed to have some familiarity with this method. The literature is extensive, with some representative papers included in the following references [6-8]. The authors are using the scattered field formulation of [8], but with linear time differencing.

#### APPROACH

To illustrate the method, let us consider the specific example of interest, taken from [3]. A wire dipole with half length 0.6 meters and a diameter of 0.81 mm is loaded at its midpoint, as shown in Figure 1. The dipole is located parallel to the z axis. The FDTD cell at the center of the wire is used to model the lumped load. As described in [3], this load is two diodes in series with a 100 ohm resistor (the actual measurements were made using a single diode at the base of a monopole). The total diode junction capacitance of 0.5 pF must also be included in the model for accurate results at the frequencies contained in the pulse.

In order to describe the approach used to model the diode circuit in FDTD, let us first consider an approach to approximating a linear lumped load consisting of a capacitor in parallel with a resistor (conductance) in an FDTD cell. Starting with

$$\nabla \times \bar{H} = \epsilon \frac{\partial \bar{E}}{\partial t} + \sigma \bar{E} \quad (1)$$

where H, E,  $\epsilon$  and  $\sigma$  are the magnetic and electric fields, the permittivity, and the conductivity, and following the Yee [6] approach for discretizing space and time, with  $t=n\Delta t$ ,  $x=I\Delta x$ ,  $y=J\Delta y$ ,  $z=K\Delta z$ , eq. (1) becomes, for the z component of electric field in a particular FDTD cell,

$$(\nabla \times H^{n+1/2})_z = \epsilon \frac{E_z^{n+1} - E_z^n}{\Delta t} + \sigma E_z^{n+1} \quad (2)$$

where  $\epsilon$  and  $\sigma$  pertain to the particular cell location of  $E_z$  and the superscripts denote the time reference of the particular component. Usually in applying FDTD this equation is solved for  $E^{n+1}$  in terms of the previous time values of  $E^n$  and  $H^{n+1/2}$ , with the curl H term computed using spatial finite differences. Instead, consider the physical meanings of the terms. The curl H term gives the total current density flowing in the cell surrounding the electric field component. The next term involving  $\epsilon$  and the time derivative of E is the displacement current density flowing through the cell in the z direction. The  $\sigma E^{n+1}$  term is the conduction current density flowing through the cell in the z direction. Using the cell dimensions  $\Delta x$ ,  $\Delta y$  and  $\Delta z$ , and assuming fields are constant across the cell, we can rewrite the above equation in terms of lumped elements, voltages, and currents as

$$\Delta x \Delta y (\nabla \times H^{n+1/2})_z = C \Delta z \frac{E_z^{n+1} - E_z^n}{\delta t} + G \Delta z E_z^{n+1} \quad (3)$$

where now the first term is the total current flowing through the cell, C is the lumped "parallel plate" capacitance of the cell, and G is the lumped conductance in parallel with the capacitance. Note that one can identify  $\Delta z E^{n+1}$  as the voltage across the cell. Clearly a lumped capacitance C can be equivalent to setting an appropriate value of the  $\epsilon$  of the cell based on the cell dimensions, and similarly for a lumped resistance and the  $\sigma$  of the cell. Thus a lumped load that is a parallel combination of a capacitor and a conductance (resistance) can be modeled simply by setting the cell values of  $\epsilon$  and  $\sigma$  appropriately. Equations (2) and (3) are interchangeable in terms of solving for  $E^{n+1}$ .

However, one warning is that the cell permittivity cannot be set too low. FDTD in the form presented in this paper cannot in general model materials with an epsilon that is too small (much less than free space) without becoming unstable. Such materials can be modeled using FDTD modified for frequency dependent materials [9], but with additional computational effort. If the conductance  $G$  (conductivity  $\sigma$ ) is great enough so that the displacement current term in eq. (2) (or (3)) can be neglected then this term may be dropped. Indeed, if (2) or (3) is solved for  $E^{n+1}$  and  $G$  (or equivalently  $\sigma$ ) is allowed to go to infinity, the correct result of  $E^{n+1}=0$  is obtained. However, making  $G$  (or  $\sigma$ ) small enough so that the conduction current is smaller than the displacement current through the cell filled with free space, but nevertheless neglecting this displacement current term, will result in instabilities. A physical argument for this is that the capacitance of an FDTD cell cannot be made lower than the capacitance of the cell filled with free space by adding lumped elements in parallel with the cell capacitance.

Now let us proceed to extend this approach to the circuit of interest, shown in Figure 2. In this figure the resistance  $R$  models the input resistance of the oscilloscope used to measure the current [3]. The capacitance  $C$  represents the capacitance of the free space FDTD cell plus the junction capacitance of the diode. The diode junction capacitance of the diode is not actually in parallel with the resistor, but this approximation simplifies the following derivation and does not appreciably affect the results for the circuit element sizes under consideration. Letting  $i_d$  represent the current through the diode, which is also the total conduction current through the cell, we can solve (3) for  $i_d$  obtaining

$$i_d = \Delta x \Delta y (\nabla_x H^{n+1/2})_z - \frac{C \Delta z}{\Delta t} (E_z^{n+1} - E_z^n) \quad (4)$$

Once  $i_d$  is determined from (4), the diode voltage  $v_d$  can be obtained from the equation

$$2 v_d + i_d R = v_c = \Delta z E_z^{n+1} \quad (5)$$

Since the diodes are in the circuit,  $i_d$  must also satisfy the nonlinear equations

$$i_d = 1.0 \times 10^{-8} v_d, \quad v_d \leq 0 \quad (6a)$$

$$i_d = 2.9 \times 10^{-7} [\exp(15v_d) - 1], \quad v_d \geq 0 \quad (6b)$$

where (6) are the nonlinear diode equations given in [3]. Since  $i_d$  as given in both eqs. (4) and (6a,b) must be equal, a Newton-Raphson iteration method can be applied to solve for the  $E^{n+1}$  value which produces required equality. This was the approach taken in this paper. The convergence was very fast since an initial guess for  $E^{n+1}$  of the previous value of  $E$ ,  $E^n$ , provided the Newton-Raphson iteration with a good starting value.

### DEMONSTRATION

The dipole considered in [3] is excited by a pulsed plane wave. As shown in [3], this plane wave has a peak electric field strength of approximately 390 volts. For simplicity, this pulse has been approximated for our calculations by a Gaussian pulse. The FDTD excitation pulse used for the calculations in this paper is shown in Figure 3. The actual pulse shown in [3] rings at a low amplitude out to about 3 ns, but this was neglected in the FDTD calculations.

In order to provide the necessary temporal resolution FDTD cells were chosen as 0.006 m cubes, providing a time step of 11.55 ps. For the FDTD Gaussian pulse used in this demonstration this allowed 64 time steps between the 1% of peak amplitude values. The transient currents given in [3] have a duration of

approximately 14 ns. The corresponding FDTD calculation was 1300 time steps (allowing for the incident pulse to reach the dipole), requiring 200 minutes on a 25 MHz 486 PC clone running Lahey fortran.

To approximate the wire dipole 200 FDTD cells were used. Since the wire diameter is smaller than the FDTD cell width, subcell modeling was used to adjust for this [10]. The FDTD problem space was 39 x 39 x 240 cells, and was terminated in second order Mur [11] absorbing boundaries.

Three calculations of the current through the dipole load were made and compared with results calculated by Liu and Tesche [3]. For all FDTD results the total current flowing through the FDTD cell, determined by evaluating the curl of H around the cell containing the lumped load, is plotted. In the first calculation only the 100 ohm resistor (in parallel with the free space capacitance of the FDTD cell) was included, with the results shown in Fig. 4. The agreement with the results of Liu is quite reasonable.

Next the diodes were added in series with the 100 ohm resistor, and the FDTD cell capacitance C, shown in Fig 2, was set to 0.5 pF to model the combined diode junction capacitance. FDTD results for the two cases considered in [3] were then calculated. These are shown in Figs. 5 and 6, and differ only in that the pulse initially forward biases the diode for the results in Fig. 5, but reverse biases the diode in Fig. 6. Some points taken from calculated results in [3] are included in Figs. 5 and 6 for comparison, but the interested reader on referring to [3] directly will see that the agreement between the FDTD results and both the calculated and measured results in [3] is excellent considering the different assumptions and approximations made in the analysis.

## CONCLUSIONS

In this paper an approach to model nonlinear lumped elements in the context of FDTD was presented. It was used to compute the transient current in a diode loaded long dipole antenna, and excellent agreement with previously published results was obtained. This capability extends the applicability of the FDTD method to a wide range of problems, including scattering from nonlinear loaded antennas and harmonic product generation by nonlinear elements. The method can be further extended to considering regions of nonlinear material, since the (nonlinear) material content of each FDTD cell can be specified independently. Thus extensions to scattering from targets containing nonlinear material, or to propagation through nonlinear media should be straightforward. In combination with FDTD methods for frequency dependent materials, it may also be possible to extend the method to model electromagnetic propagation through dispersive nonlinear materials, including soliton propagation through such media.

## REFERENCES

1. T. K. Sarkar and D. D. Weiner, "Scattering Analysis of Nonlinearly Loaded Antennas," IEEE Trans. Antennas and Propagat., vol. AP-24, pp 125-131, March 1976.
2. T. K. Liu and F. M. Tesche, "Analysis of Antennas and Scatterers with Nonlinear Loads," IEEE Trans. Antennas and Propagat., vol. AP-24, pp 131-139, March 1976.
3. T. K. Liu, F. M. Tesche and F. J. "Transient Excitation of an Antenna with a Nonlinear Load: Numerical and Experimental Results," IEEE Trans. Antennas and Propagat., vol. AP-25, pp 539-542, July 1977.
4. M. Kanda, "Analytical and Numerical Techniques for Analyzing an Electrically Short Dipole with a Nonlinear Load," IEEE Trans. Antennas and Propagat., vol. AP-28, pp 71-78, January 1980.



5. H. Schuman, "Time Domain scattering from a Nonlinearly loaded Wire," IEEE Trans. Antennas and Propagat., vol. AP-22, pp 611-613, July 1974.
6. K. S. Yee, "Numerical solution of initial boundary value problems involving Maxwell's equations in isotropic media," IEEE Trans. Antennas and Propagat., vol. AP-14, pp 302-307, May 1966.
7. A. Taflove and M. E. Brodwin, "Numerical solution of steady-state electromagnetic scattering problems using the time-dependent Maxwell's equations," IEEE Trans. Microwave Theory Tech., vol. MTT-23, pp 623-630, Aug. 1975.
8. R. Holland, L. Simpson, and K. Kunz, "Finite difference analysis of EMP coupling to lossy dielectric structures," IEEE Trans. Electromagnetic Compat., vol. EMC-22, pp 203-209, Aug. 1980.
9. R. Luebbers, F. Hunsberger, K. Kunz, "A Frequency-Dependent Time Domain Formulation for Transient Propagation in Plasma", IEEE Transactions on Antennas and Propagat., vol. 39, pp 29-34, January 1991.
10. K. Umashankar, A. Taflove, and B. Beker, "Calculation and experimental validation of induced currents on coupled wires in an arbitrary shaped cavity," IEEE Trans. Antennas and Propagat., vol. AP-35, pp 1248-1257, November 1987.
11. G. Mur, "Absorbing boundary conditions for the Finite Difference Approximation of the Time-Domain Electromagnetic Field Equations," IEEE Trans. on Electromagnetic Compatibility, vol. EMC-23, pp 377-382, November 1981.

## FIGURE TITLES

- Fig 1. Pulsed plane wave incident on vertical wire dipole with nonlinear load.
- Fig 2. Approximate equivalent circuit of lumped nonlinear load. Capacitance C includes both the FDTD cell capacitance and the diode junction capacitances. Resistance R simulates the input resistance of the oscilloscope used to measure the current [3].
- Fig. 3 Gaussian pulse used in the FDTD calculations to simulate the pulse used by Liu et al in [3].
- Fig. 4 Transient current flowing through 100 ohm load and parallel FDTD cell capacitance at the terminals of the wire dipole calculated using FDTD and compared with calculated results of Liu et al [3].
- Fig. 5 Total transient current flowing through equivalent circuit of Fig. 2 located at the terminals of the wire dipole calculated using FDTD and compared with calculated results of Liu et al [3]. Diode is initially forward conducting.
- Fig. 6 Total transient current flowing through equivalent circuit of Fig. 2 located at the terminals of the wire dipole calculated using FDTD and compared with calculated results of Liu et al [3]. Diode is initially reverse conducting.

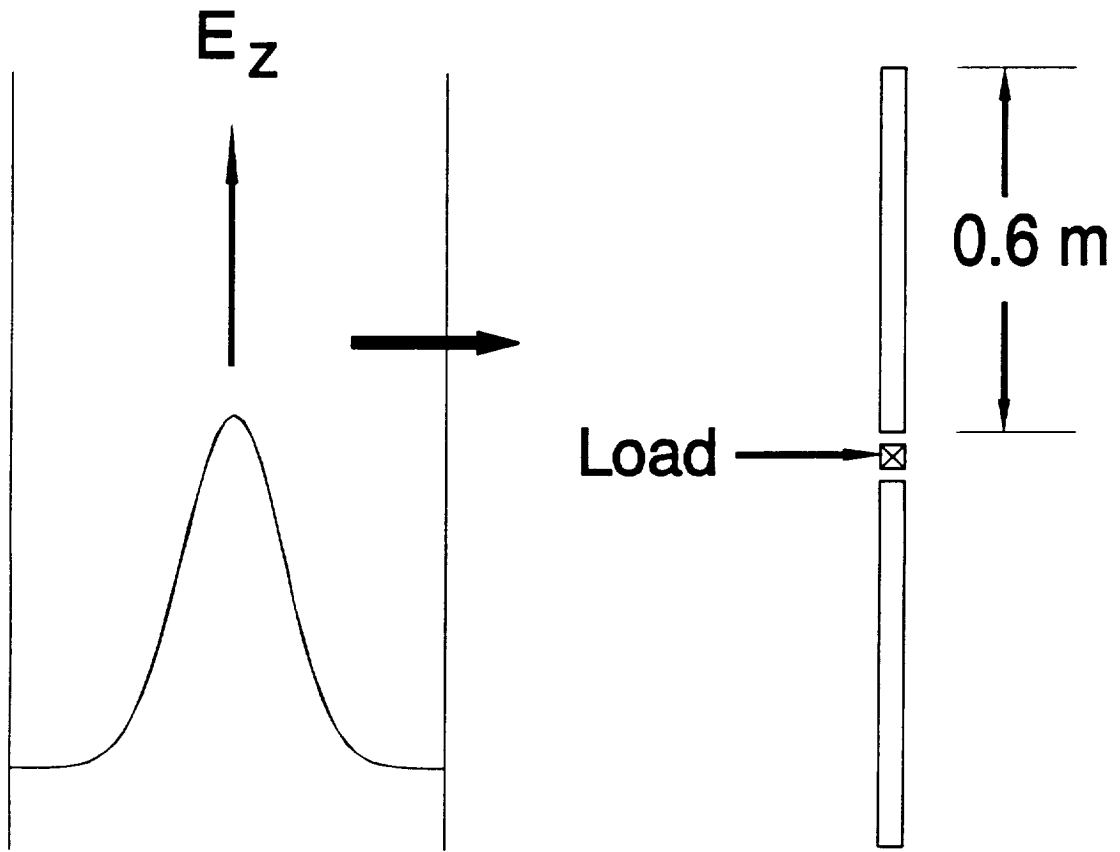

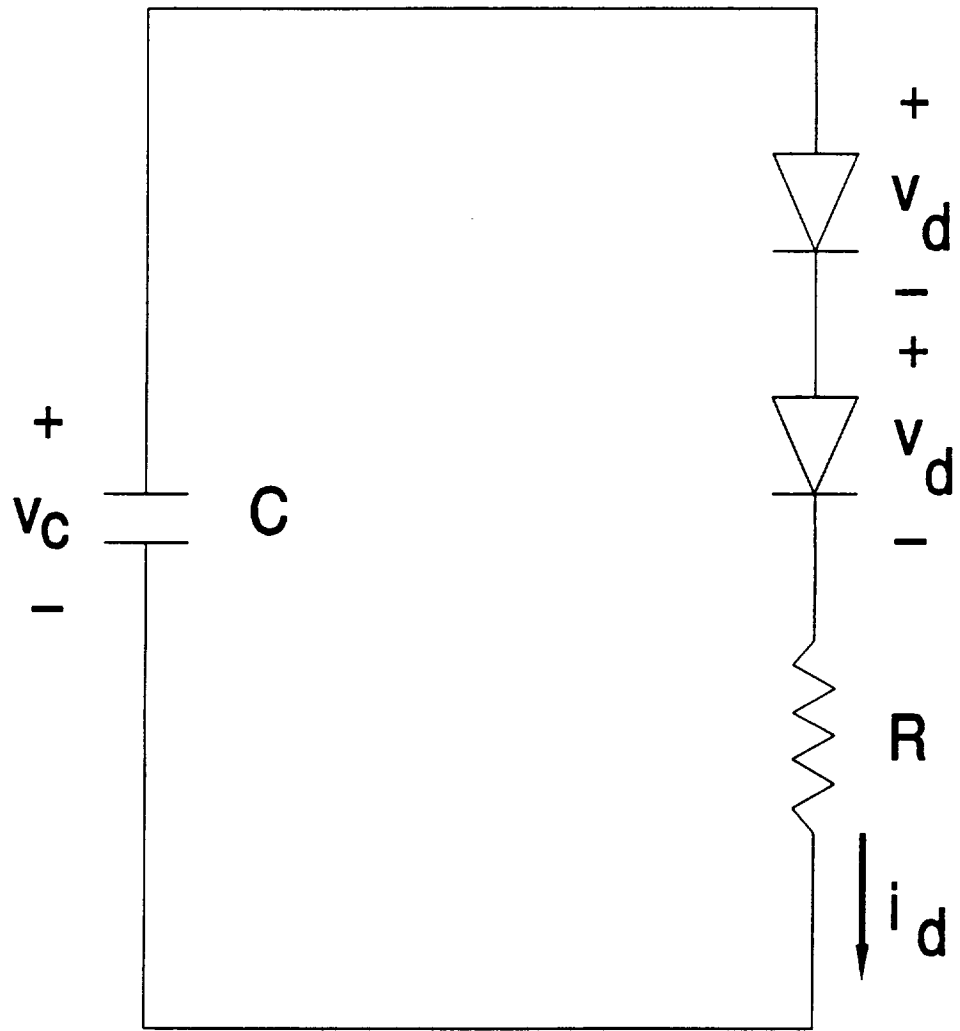

# Incident Pulse used for FDTD Calculations

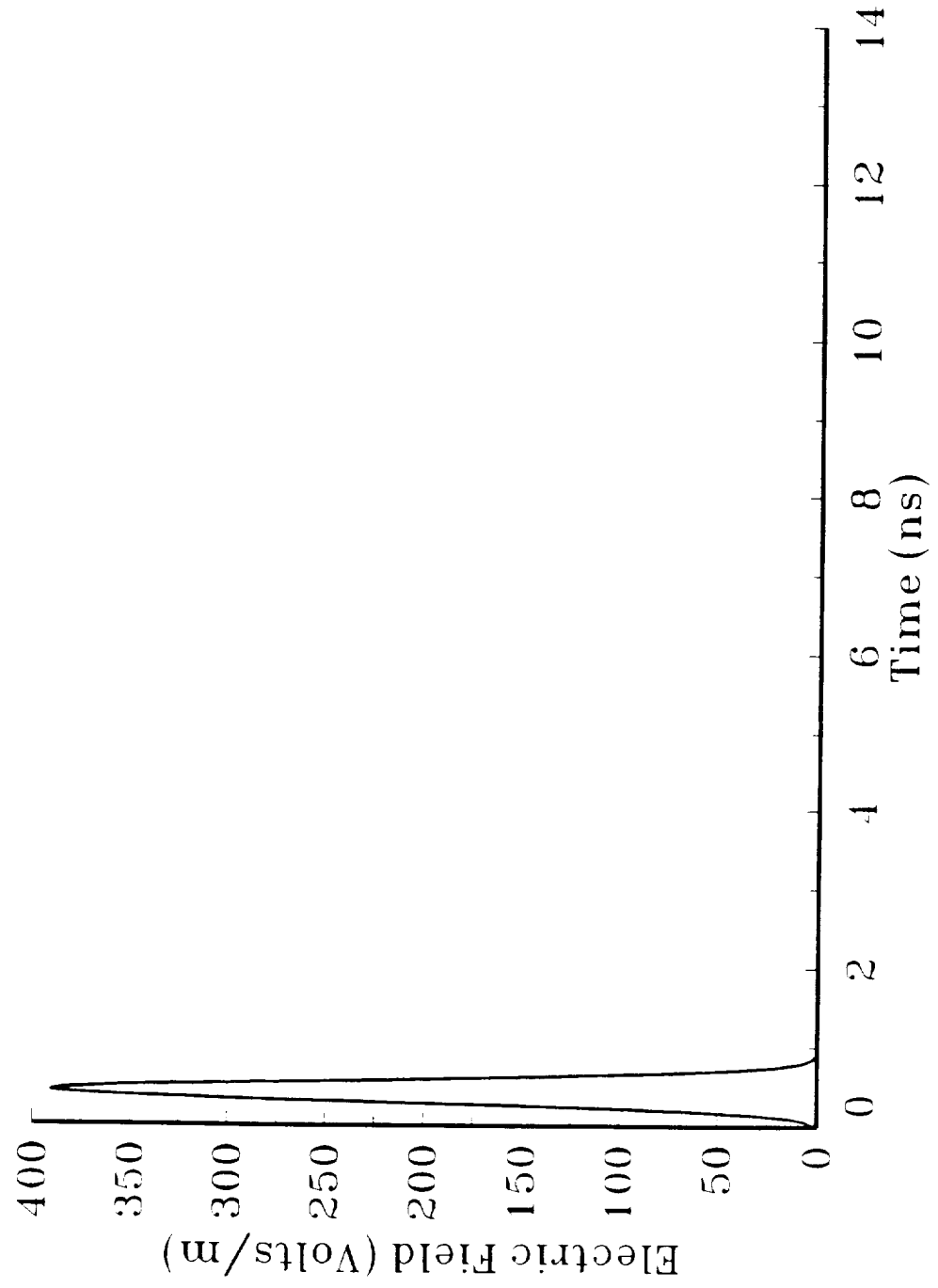

# FDTD Calculation vs Liu et al 100 ohm resistor

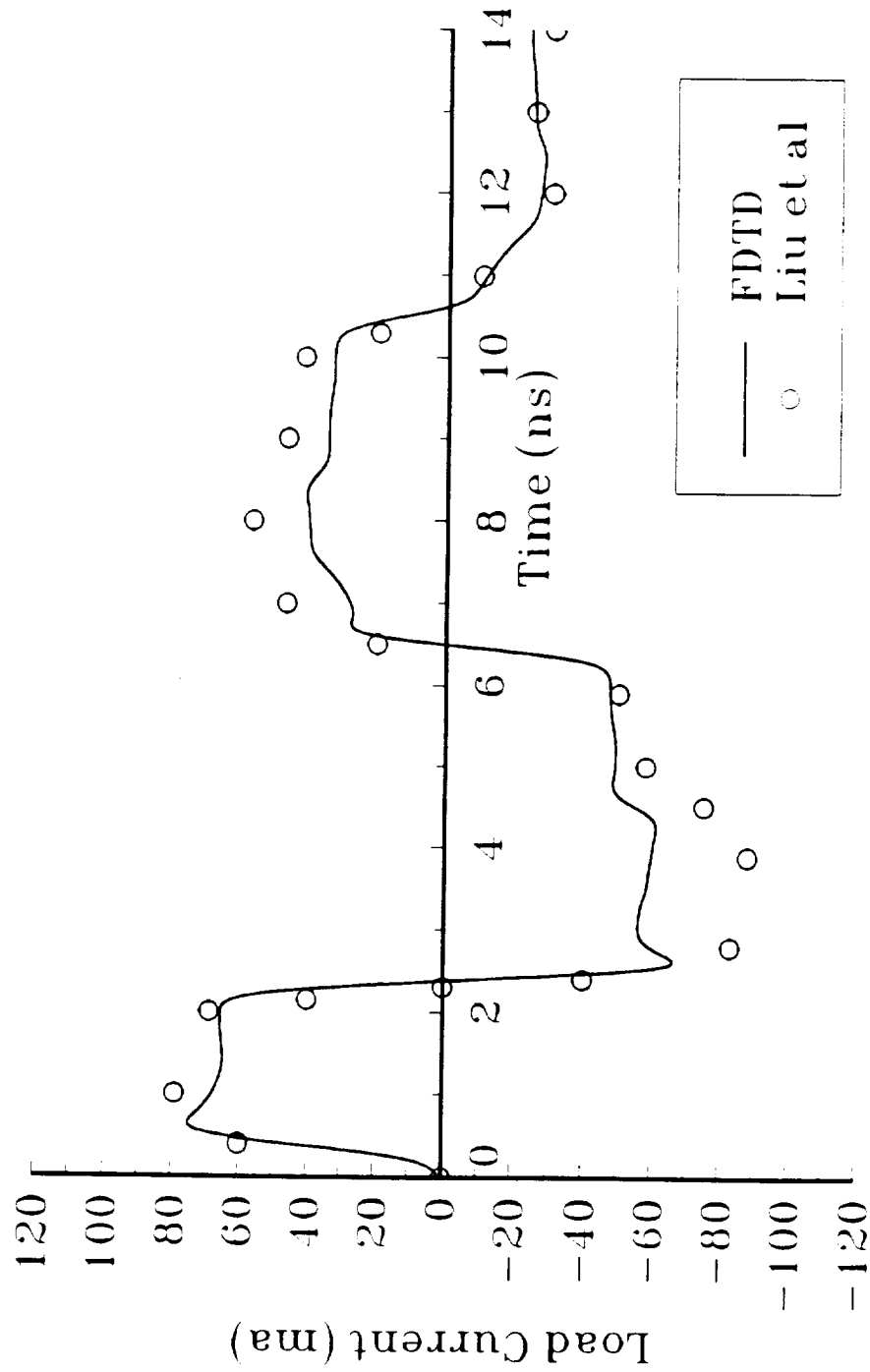

FDTD Calculation vs Liu et al  
Two diodes, 0.5 pF junction Capacitance, 100 ohm Resistor

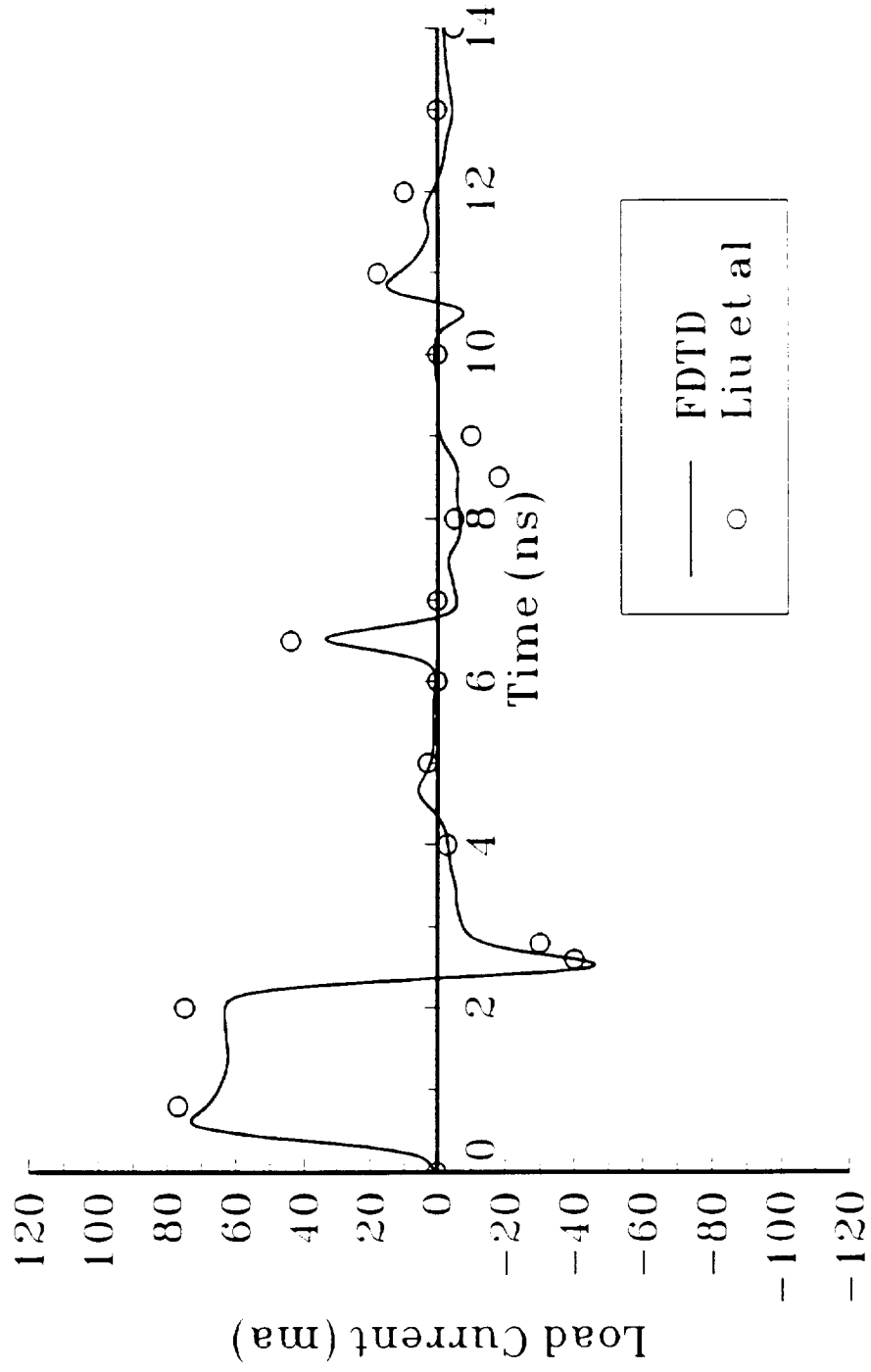

FDTD Calculation vs Liu et al  
Two Diodes, 0.5 pF junction Capacitance, 100 ohm Resistor

