

Fire Fighting Robot

Kirti Kadam¹, Aayushi Bidkar², Vaishnavi Pimpale³, Dhanashree Doke⁴, Rachana Patil⁵

^{1,2,3,4}Diploma Student, Department of Computer Engineering,
Pimpri Chinchwad Polytechnic, Pune, Maharashtra, India.

⁵Lecturer, Department of Computer Engineering,
Pimpri Chinchwad Polytechnic, Pune, Maharashtra, India.

Abstract:

Now a days, fire accidents are very common and sometimes it becomes very difficult for a fireman to save someone's life. It is not possible to appoint a person to continuously observe for accidental fire where robot can do that. Therefore in such cases fire fighting robot comes in picture. Robot will detect fire remotely. These robots are mostly useful in industries where probability of accidental fire is more.

The proposed vehicle is able to detect presence of fire and extinguishing it automatically by using gas sensor and temperature sensor. It contains gear motors and motor driver to control the movement of robot. Relay circuit is used to control the pump and when it will detect fire then it will communicate with microcontroller (Arduino UNO R3) through Bluetooth module. The proposed robot has a water jet spray which is capable of sprinkling water. The sprinkler can be move towards the required direction. At the time of moving towards the source of fire it may happen that it will come across some obstacles, then it has obstacle avoiding capability. It will provide GUI for arduino operation using android. It detects obstacles using ultrasonic sensors upto range of 80 m.

Communication between the mobile phone and robot will take place through Bluetooth, which will have GUI to control the movement of robot. When mobile gets connected to Bluetooth firstly it will set module name, baud rate.

It is feasible to implement Bluetooth communication between smartphones and microcontroller. Android controlled robot can be used easily in everyday life such as in homes, market, companies etc. The development of apps for Android in Android SDK is easy and free of cost.

I. Introduction

Previously Fire Fighting Robots were controlled by using different electronics devices But this reduces the scope of control of fire fighting robot. However, with the advanced techniques we can build the same robot by using android application to control the actions of the robot. With the help of such robots, fireman's work really decreased and movements of robot are so much effective. By using an android app fireman can detect the fire and can be able to extinguish it. At the same time robot can detect the obstacles and can avoid them by using ultrasonic sensors.

Our project is designed to build an android application which can control operations of the fire fighting robot. Fireman can send commands to robot through Bluetooth module which is mounted on robot itself. Smart phones has facility of Bluetooth, through that Bluetooth fireman can control the movement of firefighting robot. For fire detection it is using two sensors. One is temperature sensor and second is smoke detector. Fire extinguishing system will be get activated when fire detection system detects fire. Sprinkler will start sprinkling water when it detects fire. At the transmitting end android application is used and at receiving end two motors are interface to microcontroller.

II. Literature Survey

In this movable robot consists of sensor like LM35 and Arduino Flame Sensors are used to detect the fire and

distances on its way towards fire. In this for the mobility of the Robot, two wheels made of Nylon and a caster ball is used. This is mainly a rear wheel drive type of vehicle. The water container has the capacity to contain at least 1L water. It is made of strong cardboard which has water resistant property.[1]

A fuzzy controller is used to control an obstacle avoidance of Vehicle. The aim is to guide the Vehicle along its path to avoid any static environments containing some static obstacles in front of it. Obstacle avoidance in real-time is a mandatory feature for Vehicle in an unknown environment.[2]

In this the human can control the robot by using the Bluetooth module. The Bluetooth module is work with the android application. In this the Bluetooth module communicate android application by using driving motor, Arduino mega, voltage divider, tires, Bluetooth, motor driver.[3]

In this there are three different types of system unit is use 1. Locomotion system 2. Fire detection system 3. Extinguishing system 4. Communication system. The Locomotion system is used for obstacle detection and four ultrasonic range finder to find the distance between obstacle and system. Fire detection system is used for the detection of fire in this the gas sensor is used. Extinguishing system is for successfully extinguish the fire.[4]

In this paper Arduino (UNO R3), gas sensor, motor driver, gear motor, Relay driver, Bluetooth module, pump

and sprinkler are used. To program Arduino UNO R3 open source software Arduino IDE is required. The detection and extinguishing was done with the help of Arduino in which the gas sensor, gear motor and its driver, relay driver etc. are interfaced. The "Android controlled firefighting robot" can be used easily in everyday life such as in homes, laboratories, parking lots, supermarkets, stores, shops etc. Important function of the robot is patrolling. Limitation of the robot is Bluetooth range and water capacity.[5]

III. Design And Proposed Work

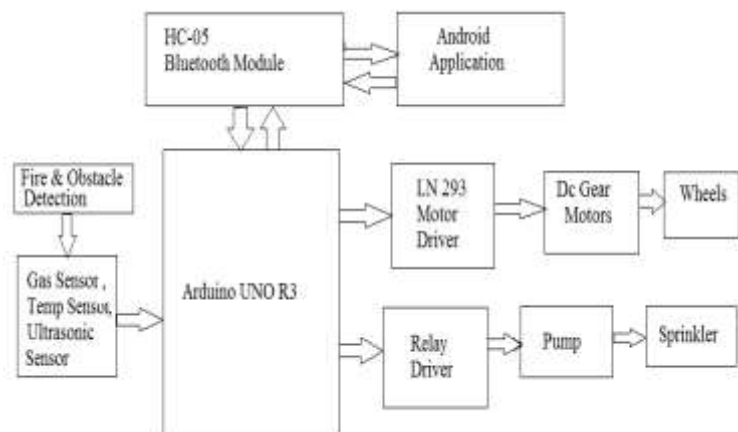

Fig. Architecture Diagram

IV. Modules

- ❖ Obstacle detection Module:
 - Check whether there is obstacle in front of the robot.
 - If obstacle is within the certain range then stop the robot.
- ❖ Fire detection Module:
 - The robot will move in the room and detect the fire.
 - If the temperature at certain place is more than the threshold set then start the water sprinkler.
 - Else detect the fire inside the room.
- ❖ Fireman Module:
 - When the robot will be moving inside the room it can be controlled by the fireman using android phone.
 - When obstacle detected the robot will be guided by the fireman where to move.
 - The camera on the robot will allow fireman to analyze the situation and turn the pipe of water sprinkler.

V. Advantages

- The robot will be used at places where it is dangerous for humans to enter.
- It can move automatically inside the room without any supervision.

- The automatic water sprinkler will
- start whenever the fire is detected.
- The robot is fire resistance and can be used at situations where temperature is 120 degree Celsius.
- It can be controlled by android phone externally.

VI. Result

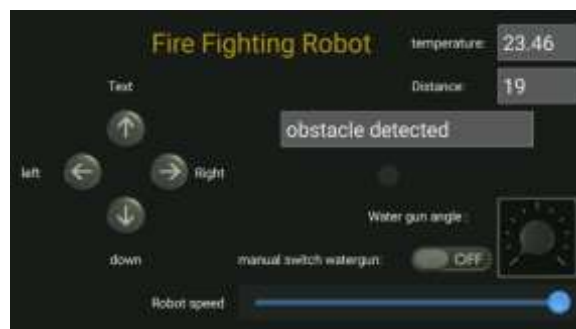

VII. Conclusion

Thus we will be developing a robot which will be used for fire fighting purpose. This proposes a great chance for automation and will be useful at places where human cannot reach or is dangerous

VIII. References

1. Tawfiqur Rakib, M. A. Rashid Sarkar Design and fabrication of an autonomous firefighting robot with multi sensor fire detection using PID controller ICIEV Volume 23 issue-1 JUNE 2016
2. Khaled Sailan , Prof. Dr. Ing. Klaus- Dieter Kuhnert Obstacle avoidance strategy using fuzzy logic steering control of amphibious autonomous vehicle
3. International journal of innovative science Engg. and Technology ,Volume 2, 2015
4. Shivam Agrawal ,Nidhi Agrawal Interfacing of robot with android app for to and fro communication IEEE ,2016
5. Saravanan P. ,Soni Ishawarya Android controlled intergrated semi autonomous fire fighting robot. International journal of innovative science Engg. and Technology 2015.
6. S. Jakthi Priyanka, R. Sangeetha Android controlled firefighting robot International journal of innovative science Engg. and Technology ,Volume 3, 2017