

NBSIR 83-2787

Fire Performance of Furnishings As Measured in the NBS Furniture Calorimeter. Part I

U.S. DEPARTMENT OF COMMERCE
National Bureau of Standards
National Engineering **Laboratory**
Center for Fire Research
Washington, DC 20234

August 1983

Issued January 1984

Supported in part by:

Department of Health and Human Services
Washington, DC

NBSIR 83-2787

**FIRE PERFORMANCE OF FURNISHINGS
AS MEASURED IN THE NBS FURNITURE
CALORIMETER. PART I**

J. Randall Lawson
W. Douglas Walton
William H. Twilley

U.S. DEPARTMENT OF COMMERCE
National Bureau of Standards
National Engineering Laboratory
Center for Fire Research
Washington, DC 20234

August 1983

Issued January 1984

Supported in part by:
Department of Health and Human Services
Washington, DC



U.S. DEPARTMENT OF COMMERCE, Malcolm Baldrige, *Secretary*
NATIONAL BUREAU OF STANDARDS, Ernest Ambler, Director

TABLE OF CONTENTS

	<u>Page</u>
LIST OF TABLES	iv
LIST OF FIGURES	v
SI CONVERSION UNITS	xii
Abstract	1
1. INTRODUCTION	2
2. FURNITURE SPECIMENS AND WARDROBE FABRIC LOADS	6
2.1 Furniture Specimens	6
2.2 Wardrobe Fabric Loads	6
3. APPARATUS AND PROCEDURE	9
3.1 Description of Apparatus	9
3.2 Test Procedure	13
3.2.1 Calibration	13
3.2.2 Chairs, Sofas and Bookcase, Gas Flame Ignition	13
3.2.3 Chair and Bedding, Cigarette and Lighter Ignition	14
3.2.4 Wardrobes, Match Ignition	15
4. EASY CHAIRS	16
4.1 Description of Easy Chairs	16
4.2 Results and Discussion of Easy Chair Tests	17
5. WAITING ROOM AND PATIENT CHAIRS	36
5.1 Description of Waiting Room and Patient Chairs	36
5.2 Results and Discussion of Waiting Room and Patient Chair Tests	38
6. SOFAS AND BEDDING	64
6.1 Description of Sofas and Bedding	64
6.2 Results and Discussion of Sofa and Bedding Tests	65
7. WARDROBE CLOSETS AND BOOKCASE	82
7.1 Description of Wardrobe Closets and Bookcase	82
7.2 Results and Discussion of Wardrobe Closet and Bookcase Tests	84
7.2.1 Metal Wardrobes	84
7.2.2 Plywood Wardrobes (12.7 mm)	85
7.2.3 Plywood Wardrobes (3.2 mm)	86
7.2.4 Particleboard Wardrobe and Bookcase	88
8. SUMMARY	117
9. ACKNOWLEDGEMENTS	119
10. REFERENCES	120

LIST OF TABLES

	<u>Page</u>
Table 1. List of Tests	5
Table 2. Simulated Clothing	8
Table 3. Simulated Clothing, Test 61	8
Table 4. Test Results on Easy Chairs	20
Table 5. Test Results on Waiting Room and Patient Chairs	40
Table 6. Test Results on Sofas and Bedding	68
Table 7. Test Results on Wardrobe Closets and Bookcase	90

LIST OF FIGURES

	<u>Page</u>
Figure 1. Furniture calorimeter, schematic of flow and instrumentation	12
Figure 2. Photograph and dimensions of easy chair with "California foam" cushions, test 45	21
Figure 3. Rate of heat release plot for easy chair, test 4.5	22
Figure 4. Rate of mass loss plot for easy chair, test 45	22
Figure 5. Target irradiance plot for easy chair, test 45	23
Figure 6. Smoke particulate conversion plot for test 45	23
Figure 7. Photograph and dimensions of easy chair with foam cushions, test 48	24
Figure 8. Rate of heat release plot for easy chair, test 48	25
Figure 9. Rate of mass loss plot for easy chair, test 48	25
Figure 10. Target irradiance plot for easy chair, test 48	26
Figure 11. Smoke particulate conversion plot for test 48	26
Figure 12. Photograph and dimensions of easy chair with foam cushions, test 49	27
Figure 13. Rate of heat release plot for easy chair, test 49	28
Figure 14. Rate of mass loss plot for easy chair, test 49	28
Figure 15. Target irradiance plot for easy chair, test 49	29
Figure 16. Smoke particulate conversion plot for easy chair, test 49	29
Figure 17. Photograph and dimensions of easy chair, molded flexible urethane frame, test 64	30
Figure 18. Rate of heat release plot for easy chair, test 64	31
Figure 19. Rate of mass loss plot for easy chair, test 64	31
Figure 20. Target irradiance plot for easy chair, test 64	32
Figure 21. Smoke particulate conversion plot for easy chair, test 64	32

Figure 22.	Photograph and dimensions of easy chair, cigarette ignition, test 66.....	33
Figure 23.	Rate of heat release plot for easy chair, test 66.....	34
Figure 24.	Rate of mass loss plot for easy chair, test 66.....	34
Figure 25.	Target irradiance plot for easy chair, test 66.....	35
Figure 26.	Photograph and dimensions of adjustable back patient chair, test 47.....*	41
Figure 27.	Rate of heat release plot for patient chair, test 47...	42
Figure 28.	Rate of mass loss plot for patient chair, test 47.....	42
Figure 29.	Target irradiance plot for patient chair, test 47.....	43
Figure 30.	Smoke particulate conversion plot for patient chair, test 47.....*	43
Figure 31.	Photograph and dimensions of minimum cushion chair, test 50.....*	44
Figure 32.	Rate of heat release plot for minimum cushion chair, test 50.....*	45
Figure 33.	Target irradiance plot for minimum cushion chair, test 50.....a.....	45
Figure 34.	Photograph and dimensions of molded fiberglass chair, test 51.....*	46
Figure 35.	Rate of heat release plot for molded fiberglass chair, test 51.....*	47
Figure 36.	Rate of mass loss plot for molded fiberglass chair, test 51.....*	47
Figure 37.	Target irradiance plot for molded fiberglass chair, test 51.....	48
Figure 38.	Photograph and dimensions of molded plastic patient chair, test 52.....*	49
Figure 39.	Rate of heat release plot for molded plastic patient chair, test 52.....*	50
Figure 40.	Rate of mass loss plot for molded plastic patient chair, test 52.....I.....	50
Figure 41.	Target irradiance plot for molded plastic patient chair, test 52.....	51

Figure 42.	Smoke particulate conversion plot for molded plastic patient chair, test 52*	51
Figure 43.	Photograph and dimensions of metal frame chair, test 53*...*	52
Figure 44.	Rate of heat release plot for metal frame chair, test 53	53
Figure 45.	Rate of mass loss plot for metal frame chair, test 53	53
Figure 46.	Target irradiance plot for metal frame chair, test 53**...*	54
Figure 47.	Smoke particulate conversion plot for metal frame chair, test 53*...*...*	54
Figure 48.	Photograph and dimensions of chair from group setting, test 55	55
Figure 49.	Rate of heat release plot for chair from group setting, test 55*...*	56
Figure 50.	Rate of mass loss plot for chair from group setting, test 55	56
Figure 51.	Target irradiance plot for chair from group setting, test 55*a...**	57
Figure 52.	Smoke particulate conversion plot for chair from group setting, test 55*...*	57
Figure 53.	Photograph and dimensions of chair with latex foam cushions, test 56	58
Figure 54.	Rate of heat release plot for chair with latex foam cushions, test 56*...**...*	59
Figure 55.	Rate of mass loss plot for chair with latex foam cushions, test 56*...*...*	59
Figure 56.	Target irradiance plot for chair with latex foam cushions, test 56**...**...*...*	60
Figure 57.	Smoke particulate conversion plot for chair with latex foam cushions, test 56a...*	60
Figure 58.	Photograph and dimensions of metal frame stackable chairs, test 75\`.....	61
Figure 59.	Rate of heat release plot for metal frame stackable chairs, test 75	62

Figure 78.	Photograph and dimensions of mattress and boxspring, test 67	78
Figure 79.	Rate of heat release plot for mattress and boxspring, test 67	79
Figure 80.	Target irradiance plot for mattress and boxspring, test 67 **.....*.....*.....*	79
Figure 81.	Photograph and dimensions of mattress, test 74	80
Figure 82.	Rate of heat release plot for mattress, test 74.....	81
Figure 83.	Photograph of metal wardrobe and fabric load and sketch of metal wardrobe.....	91
Figure 84.	Rate of heat release plot for metal wardrobe, test 15..	92
Figure 85.	Rate of mass loss plot for metal wardrobe, test 15.....	92
Figure 86.	Rate of heat release plot for metal wardrobe, test 21..	93
Figure 87.	Rate of mass loss plot for metal wardrobe, test 21.....	93
Figure 88.	Target irradiance plot for metal wardrobe, test 21.....	94
Figure 89.	Smoke particulate conversion plot for metal wardrobe, test 21 *.....*	94
Figure 90.	Photograph and sketch of 12.7 mm plywood wardrobe.....	95
Figure 91.	Rate of heat release plot for 12.7 mm plywood wardrobe, test 39	96
Figure 92.	Rate of mass loss plot for 12.7 mm plywood wardrobe, test 39	96
Figure 93.	Target irradiance plot for 12.7 mm plywood wardrobe, test 39	97
Figure 94.	Smoke particulate conversion plot for 12.7 mm plywood wardrobe, test 39	97
Figure 95.	Rate of heat release plot for 12.7 mm plywood wardrobe, test 40 . ..*.....*****.....*	98
Figure 96.	Rate of mass loss plot for 12.7 mm plywood wardrobe, test 40".....*.....*.....*.....*	98
Figure 97.	Target irradiance plot for 12.7 mm plywood wardrobe, test 40 *.....*.....*.....*	99
Figure 98.	Smoke particulate conversion plot for 12.7 mm plywood wardrobe, test 40	99
Figure 99.	Rate of heat release plot for 12.7 mm plywood wardrobe, test 43	100

Figure 100.	Rate of mass loss plot for 12.7 mm plywood wardrobe, test 43*	100
Figure 101.	Target irradiance plot for 12.7 mm plywood wardrobe, test 43	101
Figure 102.	Smoke particulate conversion plot for 12.7 mm plywood wardrobe, test 43	101
Figure 103.	Photograph and sketch of 3.2 mm plywood wardrobe.....	102
Figure 104.	Rate of heat release plot for 3.2 mm plywood wardrobe, test 41	103
Figure 105.	Rate of mass loss plot for 3.2 mm plywood wardrobe, test 41*	103
Figure 106.	Target irradiance plot for 3.2 plywood wardrobe, test 41	104
Figure 107.	Smoke particulate conversion for 3.2 mm plywood wardrobe, test 41	104
Figure 108.	Rate of heat release plot for 3.2 mm plywood wardrobe painted inside with one coat of fire-retardant paint, test 42	105
Figure 109.	Rate of mass loss plot for 3.2 mm plywood wardrobe painted inside with one coat of fire-retardant paint, test 42*	105
Figure 110.	Target irradiance plot for 3.2 mm plywood wardrobe painted inside with one coat of fire-retardant paint, test 42*	106
Figure 111.	Carbon monoxide production plot for 3.2 mm plywood wardrobe painted inside with one coat of fire-retardant paint, test 42	106
Figure 112.	Smoke particulate conversion plot for 3.2 mm plywood wardrobe painted inside with one coat of fire-retardant paint, test 42	107
Figure 113.	Rate of heat release plot for 3.2 mm plywood wardrobe painted inside and out with two coats of fire-retardant latex paint, test 44*	108
Figure 114.	Rate of mass loss plot for 3.2 mm plywood wardrobe painted inside and out with two coats of fire-retardant latex paint, test 44	108

Figure 115.	Target irradiance plot for 3.2 mm plywood wardrobe painted inside and out with two coats of fire-retardant latex paint, test 44.....	109
Figure 116.	Smoke particulate conversion plot for 3.2 mm plywood wardrobe painted inside and out with two coats of fire-retardant latex paint, test 44.....	109
Figure 117.	Comparison of heat release rates from test 41 and test 44.....	110
Figure 118.	Comparison of target irradiance experienced in test 41 and test 44*	110
Figure 119.	Comparison of smoke particulate conversion for test 41 and test 44*	111
Figure 120.	Photograph and sketch of 19.1 mm particleboard wardrobe, test 61*	112
Figure 121.	Rate of heat release plot for 19.1 mm particleboard wardrobe, test 61I.....	113
Figure 122.	Rate of mass loss plot for 19.1 mm particleboard wardrobe, test 61.....	113
Figure 123.	Target irradiance plot for 19.1 mm particleboard wardrobe, test 61.....*	114
Figure 124.	Smoke particulate conversion plot for 19.1 mm particleboard wardrobe, test 61.....	114
Figure 125.	Photograph and sketch of 12.7 mm wood bookcase, test 62.....	115
Figure 126.	Rate of heat release plot for 12.7 mm wood bookcase, test 62*	116

SI CONVERSION UNITS

AREA

$$\begin{aligned}1 \text{ in}^2 &= 0.000645 \text{ squameter } (\text{m}^2) \\ &= 6.4516 \text{ square centimeters } (\text{cm}^2) \\1 \text{ ft}^2 &= 0.0929 \text{ squameter } (\text{m}^2)\end{aligned}$$

LENGTH

$$\begin{aligned}1 \text{ in} &= 0.0254 \text{ meter } (\text{m}) \\1 \text{ ft} &= 0.3048 \text{ meter } (\text{m})\end{aligned}$$

MASS

$$1 \text{ lb} = 0.453 \text{ kilogram } (\text{kg})$$

POWER

$$1 \text{ watt} = 1 \text{ joule per second } \left(\frac{\text{J}}{\text{s}}\right)$$

QUANTITY OF HEAT

$$1 \text{ BTU} = 1055.87 \text{ joule } (\text{J})$$

TEMPERATURE

$$\text{degree Fahrenheit } (^\circ\text{F}) = 9/5 \text{ } ^\circ\text{C} + 32$$

FIRE PERFORMANCE OF FURNISHINGS AS MEASURED
IN THE NBS FURNITURE CALORIMETER. PART I

J. Randall Lawson, W. Douglas Walton, William H. Twilley

Abstract

A heat release rate **calorimeter** developed at the National Bureau of Standards was used to measure the free burning characteristics of 23 different types of furnishings. A total of 28 heat release rate experiments were carried out during this project. The heat release rates measured in the calorimeter were determined through the use of an oxygen consumption technique. Data are given on the rates of mass loss, thermal radiation, and smoke production from the burning furniture specimens. The furnishings evaluated are classed into the following groups: easy chairs, sofas, waiting room and patient chairs, wardrobe closets, bookcases and bedding.

Key Words: Furniture; calorimeter; fire performance; heat release rate; mass loss rate; radiant energy; smoke.

1. INTRODUCTION

It is well known in the fire protection community that furnishings are generally major contributors to the rate of fire growth and are often responsible for the peak energy released during an unwanted fire. This fact is particularly important to the designers and operators of hospitals and nursing homes where large numbers of people reside and patient response to fire emergencies may be impaired. A number of multiple life loss fires in medical care facilities have occurred in the last few years, and in most cases, furniture items were the first or second item ignited. Many of these unwanted fires resulted from smoking activities by patients, but a few were associated with electrical failures and arson. In the **Wincrest** Nursing Home fire (Chicago, Illinois) during January 1976, 24 people died after an arson ignition of a wooden wardrobe closet. Only three days later, an electrical fault in the Cermak House Nursing Home in Cicero, Illinois, ignited another wardrobe closet and nightstand which resulted in the death of 8 people [1]¹. Eight people also died in the Sac-Osage Hospital (Osceola, Missouri) when a smoking accident ignited a trash basket or bedding materials [2]. Other fire incidents reported have also identified the ignition of chairs and sofas through smoking accidents. In each of the fire incidents discussed above, it was clear from the investigations that furnishings played a major role in the growth and propagation of the fires which lead to life loss and thousands of dollars in damage.

¹ Figures in brackets indicate literature references at the end of this report.

Attempts have been made in recent years to evaluate the burning behavior of furnishings. These studies have primarily been concerned with the evaluation of ignitability using small ignition sources such as cigarettes [3]. Investigations have also been conducted on flame propagation over fabrics used in furnishings, and large scale room fire tests using furnishings have been carried out to develop information on how furnishings contribute to the growth of fire in compartments [4,5]. The large scale room fire studies demonstrated that two extremely important factors in the analysis of fire growth in furniture were missing. These related to knowledge concerning the rate of fire growth over and the amount of heat released from a burning piece of furniture. Until recently, there was no satisfactory way for measuring these quantities.

A heat release rate calorimeter has now been developed by the National Bureau of Standards (NBS) specifically for measuring the mass loss and heat release rates of furniture [6]. In the work reported here, a wide variety of furnishings that may be found in health care facilities have been burned to characterize their fire behavior. For this, instrumentation was added to measure generated smoke and a remote radiometer was positioned to obtain exposure data for possible ignition of nearby building materials or furnishings.

Twenty-eight heat release rate tests were conducted during this project with 23 different types of furniture being characterized. Five of the 28 tests relate to repeatability measurements or varying specimen conditions with wardrobe closet experiments. Table 1 located at the end of this section contains a list of tests for this study. The numbering sequence for tests throughout this report represents the experiment number as carried out in the

furniture calorimeter. Tests 1 through 14 are not presented since these were developmental calibration runs used to debug the calorimeter. Other tests not included in this report relate to gas burner calibrations and liquid pool fire experiments. It should also be noted that the calorimeter tests were conducted on furnishings as they were obtained, and the results were then compiled into related groups.

The primary objective of this report is to provide a catalog of fire performance data on a variety of furnishings. The data generated will be useful in the development of fire safety performance standards for furnishings and aid designers and operators of health care facilities in the selection and use of furniture. Also, this report provides a data base for researchers interested in studying fire growth in compartments and mathematical modeling of fire development.

A second report, Part II, cataloging data on the fire performance of furniture will be published upon completion of the next series of fire tests.

Table 1. List of Tests

<u>Test Number</u>	<u>Purniture Item</u>
15	Metal wardrobe
21	Metal wardrobe
38	Sofa "California foam cushions"
39	12.7 mm Plywood wardrobe
40	12.7 mm Plywood wardrobe
41	3.2 mm Plywood wardrobe
42	3.2 mm Plywood wardrobe with 1 coat of fire retardant paint
43	12.7 mm Plywood wardrobe
44	3.2 mm Plywood wardrobe with 2 coats of fire retardant paint
45	Easy chair "California foam cushion"
47	Adjustable back metal frame patient chair
48	Easy chair with foam cushions
49	Easy chair with wood frame and foam cushions
50	Waiting room chair with metal frame and minimum cushion
51	Waiting room chair of molded fiberglass
52	Patient chair of molded plastic
53	Waiting room chair with metal frame and foam cushions
54	Loveseat with wood frame and foam cushions
55	Group chair with metal frame and foam cushions
56	Waiting room chair with wood frame and latex foam cushion
57	Loveseat with wood frame and foam cushions
61	19.1 mm Particleboard wardrobe
62	12.7 mm Plywood bookcase
64	Easy chair with molded flexible urethane frame
66	Easy chair with wood frame and foam cushions
67	Mattress and boxspring
74	Mattress
75	Metal frame chairs stacked four high

2. FURNITURE SPECIMENS AND WARDROBE FABRIC LOADS

2.1 Furniture Specimens

All chairs and sofas evaluated in this study were commercially manufactured. Two pieces of furniture were specially built to NBS specifications. These items were specifically constructed from common furnishings materials, but they were designed with a minimum of different types of materials in the finished product. This was done in an attempt to reduce variations in fire propagation resulting from varying materials, and it provides fire growth information on those styles of furnishings with a simple construction. The chair in test 45 and sofa in test 38 were the furnishings with the simple design. This furniture design was also used in another research project conducted by Babrauskas [6].

The only noncommercial furnishings in this study were the 12.7 mm thick plywood wardrobes (section 7). These wardrobes were built at NBS from a design used in full-scale fire tests investigating the operation of automatic sprinklers in patient rooms [7]. A total of four different wardrobe closet designs were evaluated. A description of each wardrobe closet is found in section 7.1.

2.2 Wardrobe Fabric Loads

All wardrobes were tested with simulated clothing inside. The fabric loads were the same for all tests except 15 and 61. Descriptions of these exceptions are found later in this section.

Generally, four different fabrics were placed into the wardrobes on 16 clothes hangers which were evenly distributed across the wardrobes to simulate 6 different types of clothing (see table 2). The fabrics were cut to size to equal the quantity typically found in the different types of apparel. The fabrics were conditioned in a 21°C, 50% relative humidity room until the time of the test. These fabrics were also selected to provide an agreement in test procedure with the study reported in reference [7]. An exception to this fabric loading was in test 15 where 3.18 kg of scrap cloth was hung on 8 clothes hangers spaced evenly across the wardrobe rod. This was a preliminary test to evaluate the operation of the calorimeter system with a moderate size fire. The second exception to the standard fabric loading occurred during test 61. In this case, the wardrobe compartment was not large enough to hold all of the fabrics. Seven clothes hangers were used with the simulated clothing described in table 3.

Table 2. Simulated Clothing*

Item	Quantity Per Test	Length & Width (m)	Fabric	Composition (%)	Weight (g/m ²)
Night Shirt	6	1.02 x 0.38	Knit Jersey	65 Polyester 35 Cotton	164.3
T-Shirt	2	0.76 x 0.38	Knit Jersey	65 Polyester 35 Cotton	164.3
Robe	1	0.56 x 1.35	Terry Cloth	16 Polyester 84 Cotton	342.0
Shirt	4	0.51 x 1.22	Kettle Cloth	50 Polyester 50 Cotton	161.8
Dress	2	0.61 x 2.03	Kettle Cloth	50 Polyester 50 Cotton	161.8
Pants	2	0.79 x 1.02	Double Knit	100 Polyester	245.1

* The above cloths were used in all tests except test 15 and 61.

Table 3. Simulated Clothing, Test 61*

Item	Quantity Used	Fabric
Night Shirt	1	Knit Jersey
T-Shirt	2	Knit Jersey
Robe	1	Terry Cloth
Shirt	2	Kettle Cloth
Pants	1	Double Knit

* NOTE: All fabric compositions, **weights** and cut sizes were the same as in table 2.

3. APPARATUS AND PROCEDURE

3.1 Description of Apparatus

Several different methods for measuring heat release rates have been developed over the years. These techniques and apparatus are described in detail by Chamberlain [8]. Of the available methods, the oxygen consumption technique developed by Sensenig and Parker [9,10] was selected for the test apparatus because it allowed free burning of furniture specimens without the radiation feed-back experienced in closed chambers. Briefly, Huggett [11] established that to within 5 percent the burning of materials normally used in construction and furnishings produces a constant value of heat per unit mass of oxygen consumed. This value is $E = 13.1 \text{ MJ/kg}$. Parker, taking this into consideration derived the following equation which was used as the basis for heat release rate measurements in this report.

$$\dot{Q} = 13.1 \times 10^3 \times \frac{32}{28.97} \times \frac{\dot{m}_s X_{O_2}^A d}{1+d (a-1)}, \quad (1)$$

where \dot{Q} = heat release rate (kW),

d = fraction of oxygen consumed,

$X_{O_2}^A$ = mole fraction of oxygen in air before the test ($\frac{f}{\approx} 0.203$)

$a = 1.1$ expansion factor for the fraction of air that was depleted of oxygen, and

\dot{m}_s = total gas flow in stack.

Figure 1, located at the end of this section, 3.1, shows schematically the apparatus and instrumentation. In order to determine all of the factors involved in the above equation, all of the products of combustion must be collected from the burning specimen. Two different size hood systems were used. The decision on which hood to use was based on the expected output of the burning test specimen. The smaller of the hoods is 2.64 m long and 1.73 m wide. This hood system has a fan-induced draft with a flow of approximately $1.5 \text{ m}^3/\text{s}$ at 21°C and a pressure of 760 mm Hg. It was designed to measure heat release rates up to 2000 kW. The larger hood has a flow induced by a premixed gas fired burner which is part of the building smoke abatement system. This hood produces a flow of approximately $3 \text{ m}^3/\text{s}$ at 21°C and 760 mm Hg and its size is 4.88 m long and 3.66 m wide. This hood can be used to measure heat release rates up to approximately 6000 kW.

The exhaust stacks from both hoods are instrumented in a similar way. Each stack has a sample point where stack gas temperature and velocity are measured to determine \dot{m}_s and gas samples (O_2 , CO, CO_2) are taken to determine d. The gas sample is pumped continuously from the stack and passes through a particulate filter, cold trap, and a chemical dessicant to remove solids and moisture before it passes through the pump. The gas sample is then divided and delivered in parallel to the paramagnetic oxygen analyzer and the infrared absorption carbon dioxide and carbon monoxide analyzers. Gas concentrations are monitored continuously by the analyzers, and the data are collected by a high speed data logger every 10 seconds. Calibrations of this apparatus using natural gas metered to a 0.67 m by 1.0 m burner showed that heat release rates are measured to within 10 percent of the actual value [6].

In order to further characterize the burning of furniture with regard to mass loss rate, smoke generation, and thermal radiation, additional instrumentation was fitted to the calorimeter systems. The specimens sit on a load cell platform which provides continuous data on the mass burning rate for use in the calculation of instantaneous heats of combustion and mass converted into smoke. An extinction-beam photometer [12] is located in each exhaust stack to measure smoke generated by the burning specimen. The smoke results are expressed as the mass particulate conversion percent. A Gardon gage located 0.5 m in front of the specimen and 0.5 m above the load platform floor measures the radiant heat flux experienced at that point throughout the test. This provides information on the possibility of secondary ignitions occurring through thermal radiation emitted by the burning specimen.

FURNITURE CALORIMETER

Schematic of Flow and Instrumentation

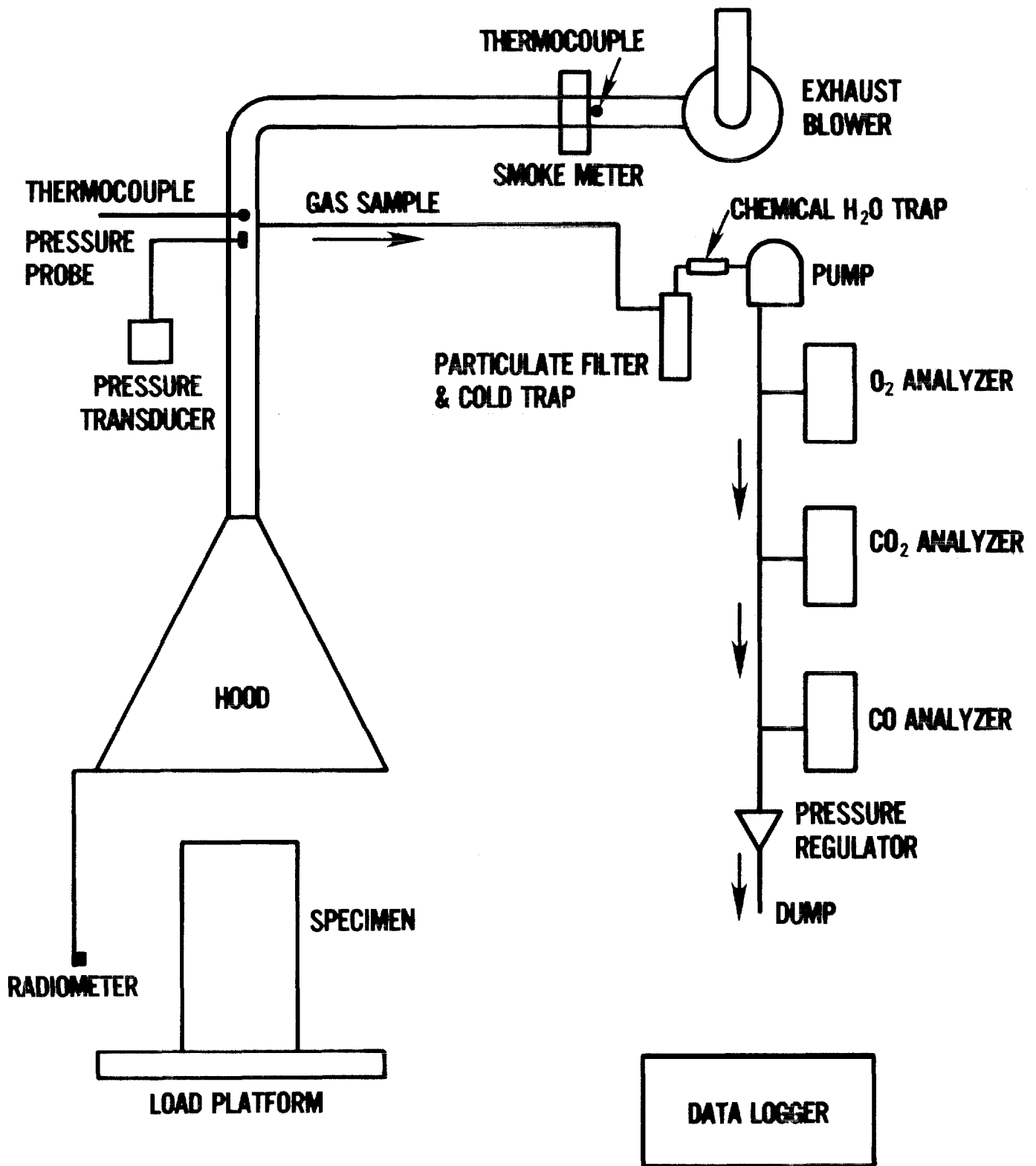

Figure 1. Furniture calorimeter, schematic of flow and instrumentation

3.2 Test Procedure

3.2.1 Calibration

Before any tests were conducted, all instrument systems were carefully calibrated to insure proper operation for the test. The gas analyzers were zeroed with nitrogen and spanned with gases of known quality. The load platform was zeroed and spanned to a known weight approximating that of the test specimen, and the smoke meter was also zeroed and spanned for maximum transmittance. The calibration of the radiometer was periodically checked by comparison to a precision radiant energy source, and it was checked for output before each fire test by exposure to a gas flame.

3.2.2 Chairs, Sofas and Bookcase, Gas Flame Ignition (Tests #38, 45, 47-57, 62, 64, 75)

Each chair, sofa or bookcase was weighed prior to testing to determine its mass. The test specimen was then placed on the load platform. The data system was started and a gas burner was ignited just outside of the collection hood. The heat release rate and time of flame exposure to the specimen was designed to simulate the peak burning rate of a wastebasket [13]. The natural gas flow was set to deliver a constant heat release rate of 50 kW. The ignition source was then moved into place, approximately 25 mm from the specimen's side and 250 mm above the load platform. An event marker switch was closed to identify the beginning of the test for the computer program. The computer program subtracted the heat released from the ignition source from the test results. The ignition source was left in position for 200 seconds and was then removed from the test apparatus and extinguished. The furniture specimen

was then allowed to burn freely until the item was completely consumed or the flame went out, At this point, an event marker switch was closed to indicate the test's end.

3.2.3 Chair and Bedding, Cigarette and Lighter Ignition (Tests #66, 67, 74)

The easy chair evaluated in test 66 was burned while sitting on the load platform and data on mass loss rate were obtained. Neither of the bedding tests, numbers 67 and 74, were conducted using the load platform because the beds were too large; therefore, mass loss data were not taken.

The easy chair evaluated in test 66 was placed onto the load platform. A non-filtertip cigarette measuring 84 mm long was lit and placed between the seat cushion and left chair arm. The cigarette burned completely and ignited the chair.

The ignition source used in the two bedding tests was a gas cigarette lighter. The mattress and boxspring in test 67 was covered with a bed sheet. Attempts to ignite this mattress with several smoldering cigarettes were **unsuccessful**. Sheet fabric hanging at one bed corner was easily ignited by a 50 mm flame developed by the cigarette lighter and the burning sheet ignited the mattress.

In test 74, the mattress was covered with a bed sheet and a blanket. Several attempts were made to ignite the bedding with smoldering cigarettes placed under the sheets in direct contact with the mattress. The mattress could not be ignited in this way. As in test 67, the sheet and blanket

covering the mattress was ignited by a 50 mm flame from a cigarette lighter and flames from the sheet ignited the mattress.

3.2.4 Wardrobes, Match Ignition (Tests #15, 21, 39-44, 61)

All wardrobes were tested using the following procedure. The wardrobes were weighed and then placed on the apparatus load platform. A cardboard box, measuring 305 x 305 x 305 mm, filled with 10 sheets of crumpled newspaper was placed in the left rear corner of the wardrobe under the fabrics hanging on the wardrobe rod. The door next to the box was closed, and the door at the other end of the wardrobe was opened 178 mm for ventilation. In test 61, the wardrobe had only one door, and it was left open 100 mm to provide ventilation. The weight of a typical box with newspaper was 0.90 kg. A book of paper matches wired to be electrically ignited was placed in the box containing the newspaper. The data logger was started and the newspaper in the box was ignited by the matches. An event marker switch was closed at the time of ignition to identify the test beginning for the computer program during data reduction. Flames emitted by the burning newspaper and cardboard box impinged on the wardrobe and fabrics. The wardrobes and their contents were allowed to burn and data were collected until the flames went out.

4. EASY CHAIRS

4.1 Description of Easy Chairs

The five chairs in this group are typical of those easy chairs found in offices, dayrooms, hotels, and private residences. The styles and construction were selected to obtain data on a varied sample of chairs currently being manufactured. Figures with photographs of each piece of furniture in this category are located with plots of the test data at the end of section 4.2.

Test 45 - This chair had a wood frame and its cushions were made from a type of polyurethane foam often called "California foam" because it meets the requirements of California State Bulletin 117. The fabric cover was **polyolefin**, and the chair's mass was **28.34** kg. (See figure 2.)

Test 48 - This chair consisted of a one-piece molded polystyrene foam frame with plywood inserts for strength and was overlaid **with** polyurethane foam padding. The fabric cover was a thin coat of foamed polyurethane **with** a polyolefin backing. The seat and back cushions were filled with solid polyurethane foam pads, and the chair's mass was 11.52 kg. (See figure 7.) The vertical object seen in the upper half of the picture and centered is the radiometer and its shielded leads.

Test 49 - This chair was constructed with a wooden frame and a seat cushion of solid polyurethane foam. Shredded polyurethane foam was used in the back cushion. The fabric cover was cotton and the chair's mass was **15.68** kg. (See figure 12.)

Test 64 - This chair consisted of a one-piece wood reinforced cold-molded flexible polyurethane foam. Metal springs were anchored to a wood base and the structure was covered by 25-50 mm of polyester batting and then covered with a polyurethane foam imitation leather. The chair's mass was 15.98 kg. (See figure 17.) [11]

Test 66 - This chair was constructed with a wood frame; it had polyurethane foam and polyester filled cushions. The fabric cover was cotton and the welt cord was twisted paper. This chair's mass was 23.02 kg. (See figure 22.)

4.2 Results and Discussion of Easy Chair Tests

The test results for easy chair fire performance are located in table 4 and figures 3 through 25. Of the five different types of easy chairs evaluated, the one constructed from "California foam" (test 45) produced the greatest peak heat release rate, total heat release, peak mass loss rate, and peak target irradiance. The peak heat release rate measured was about 2100 kW. Research by Fang and Breese [5] showed that this would be more than enough heat release rate to cause **flashover**² in an average size room. The test results are shown graphically in figures 3-6. In test 48, shown in figures 8-11, the second greatest peak heat release rate for this furniture group was measured. This heat release rate is also capable of causing flashover [5] and the target irradiance was high enough to result in the

² Flashover is defined as a sudden change in fire growth from localized burning to a fully involved burning room. Before flashover, temperatures and heat fluxes are generally near-ambient except near zones of localized burning. After flashover, the entire room is filled with flames and jets of flames typically extend out through any room opening.

ignition of nearby combustible furnishings or interior finishes [13]. This chair exhibited the highest average heat of combustion and produced the greatest quantity of smoke. The peak percent particulate conversion and the total smoke produced were very high. Carbon monoxide measurements were also high for this chair.

The chair used in test 49 showed excellent burning characteristics compared to the other easy chairs. See table 4 and figures 13-16. Its peak heat release rate was slightly greater than 200 kW and its total heat release was near 80 MJ. This chair also had the lowest level of thermal radiation emitted and the least smoke produced. Data from test 64 show another chair with generally low values, as shown in table 4 and figures 18-21. One major exception, however, is that the total heat released was about 290 MJ. In test 66, shown in figures 23-25, the chair was ignited by a smoldering cigarette. It took over 3700 seconds before the smoldering chair burst into flames, but after flaming started, it burned very rapidly. It took only 200 seconds to reach the peak burning rate. The smoke meter system did not operate properly during this test and results are not given.

A general review of the data plots show that heat release rates are closely related to the rates of mass loss. This relationship is not unexpected. The peaks in heat release rate and mass loss rate typically occur at the same time. However, it is clear that the two fire properties do not exactly duplicate each other. A partial explanation of this may be attributed to the fact that all mass lost during specimen heating does not represent combustible volatiles, and it is known that heat release rate is highly dependent upon the variable combustion processes in the fire plume and the

local fire environment. Another factor Influencing these test results **is** that heat release rate **is** a calculated value dependent upon five different measurements, each containing independent instrument errors. Three of these critical measurements are also affected by time delays related to sample gas transport. The computer program used in data reduction attempts to correct for these time delays. In comparison, mass loss rate results are determined by taking simple measurements from the load platform as the test specimen burns.

Table 4. Test Results for Easy Chairs

Item	Test No.	Specimen Mass (kg)	Heat Release Rate (kW)		Total Heat Release (MJ)	Peak Mass Loss Rate (g/s)	Average Heat of Combustion (MJ/kg)	Peak Target Irradiance (kW/m ²)	Smoke Peak Particulate Conversion (%)	Total Smoke Produced (g)	Peak Carbon Monoxide (g/s)
			Initial Peak	Secondary Peak							
Chair, California Foam Cushions	45	28.34	2100	N	340	82.5	18.1	42.0	1.7	213	1.3
Chair, Foam Cushions	48	11.52	960	N	260	38.0	33.3	23.2	16.2	774	3.1
Chair, Wood Frame Foam Cushions	49	15.68	210	N	80	14.3	23.0	7.4	1.6	33	0.5
Chair, Molded Flexible Urethane Frame	64	15.98	460	N	290	19.9	21.0	10.9	10.8	84	0.6
Chair, Wood Frame Foam Cushions	66	23.02	640	N	240	27.7	22.7	14.4	(1)	(1)	1.0

N - No second peak.

(1) - Data not included as a result of Instrumentation failure.

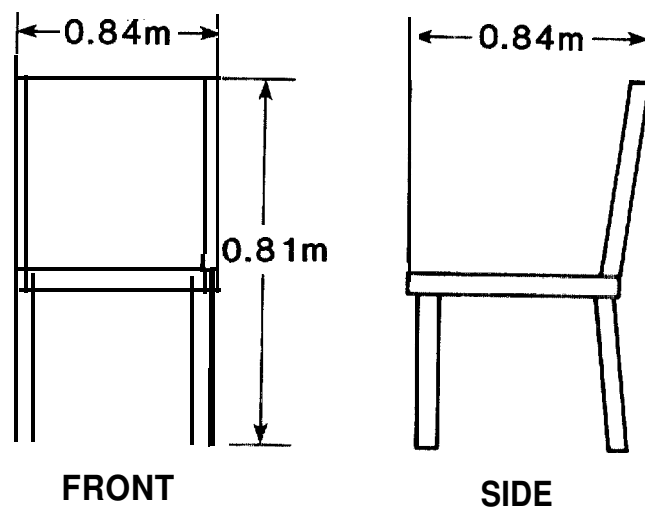
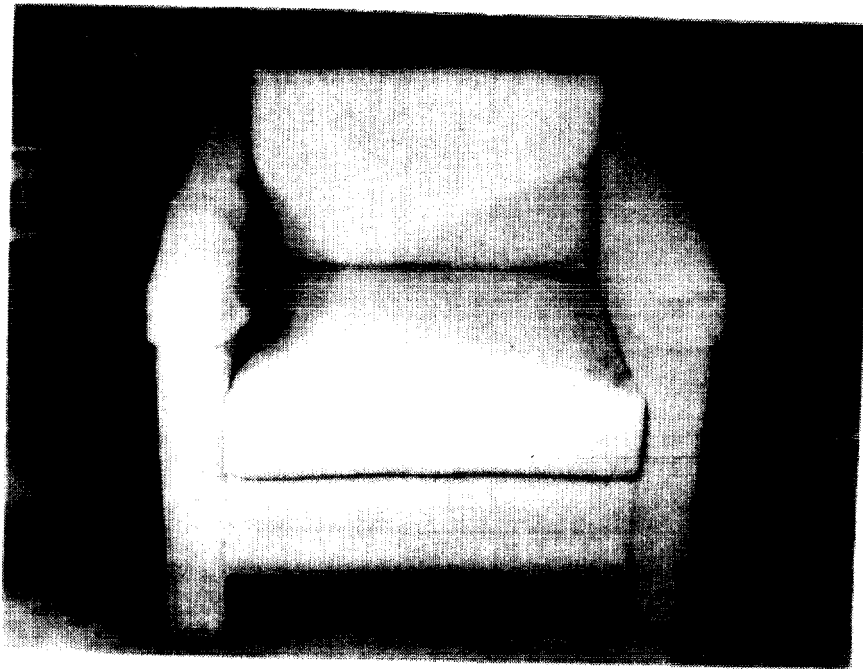

Figure 2. Photograph and dimensions of easy chair with "California foam" cushions, test 45

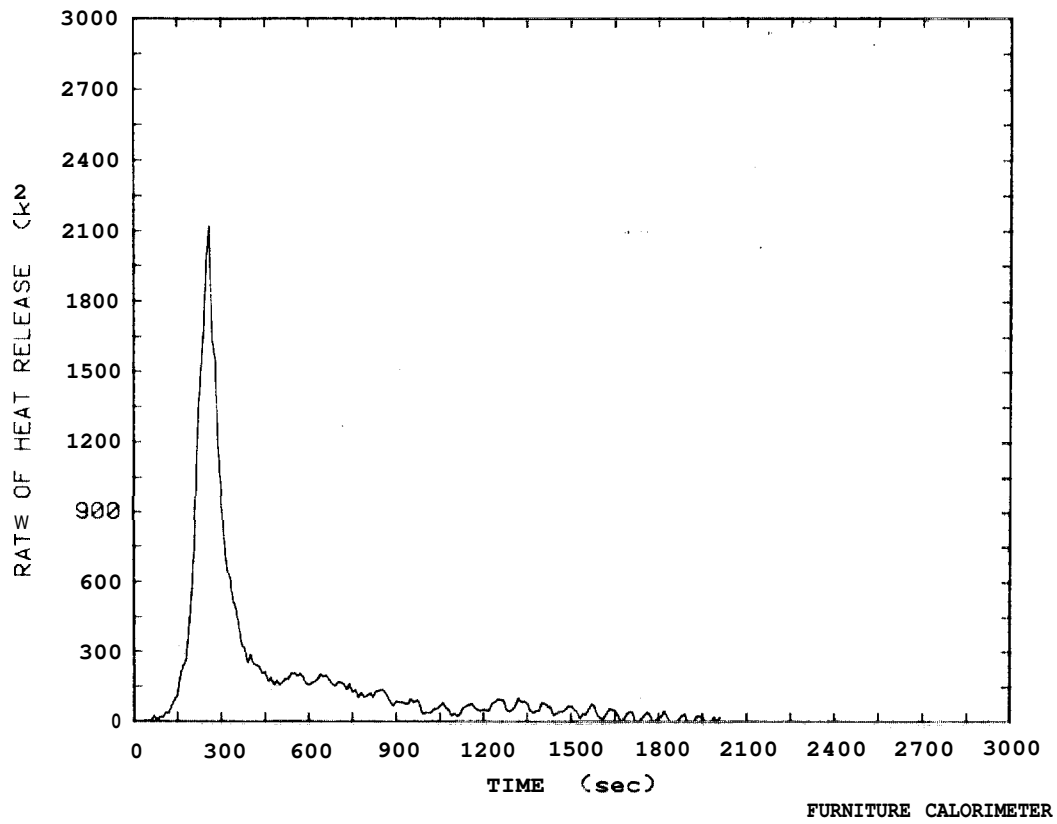

Figure 3: Rate of heat release plot for easy chair, Test 45

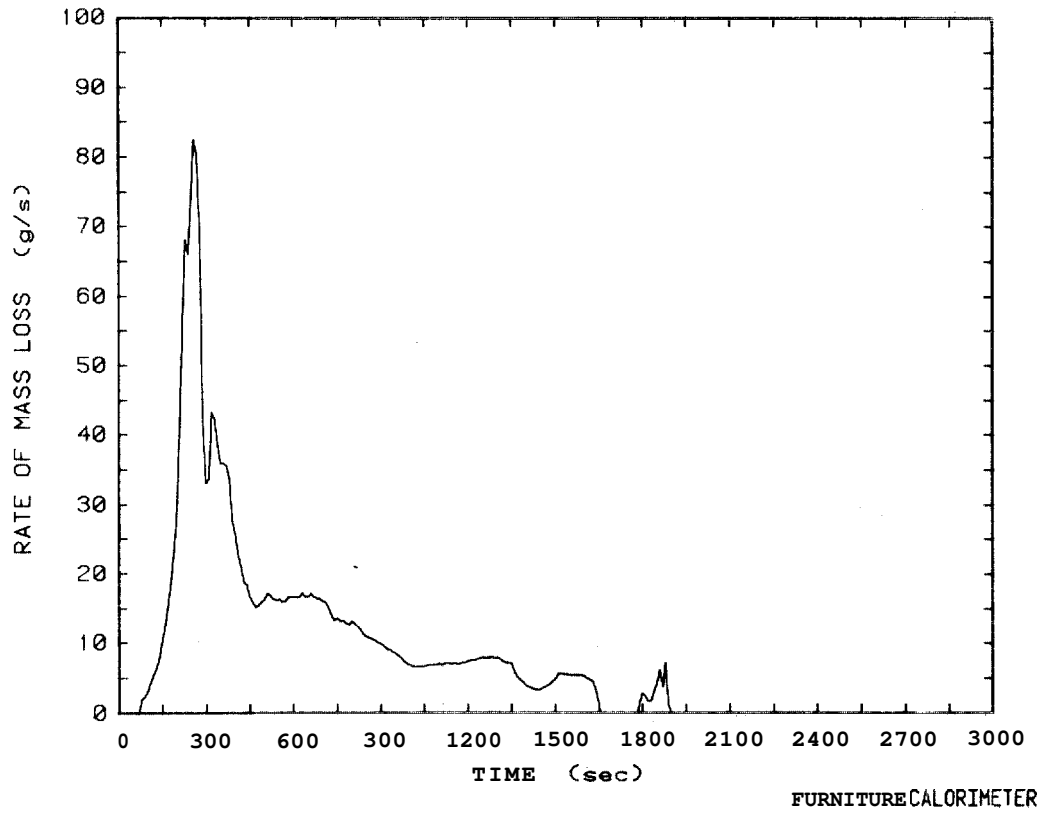

Figure 4: Rate of mass loss plot for easy chair, Test 45

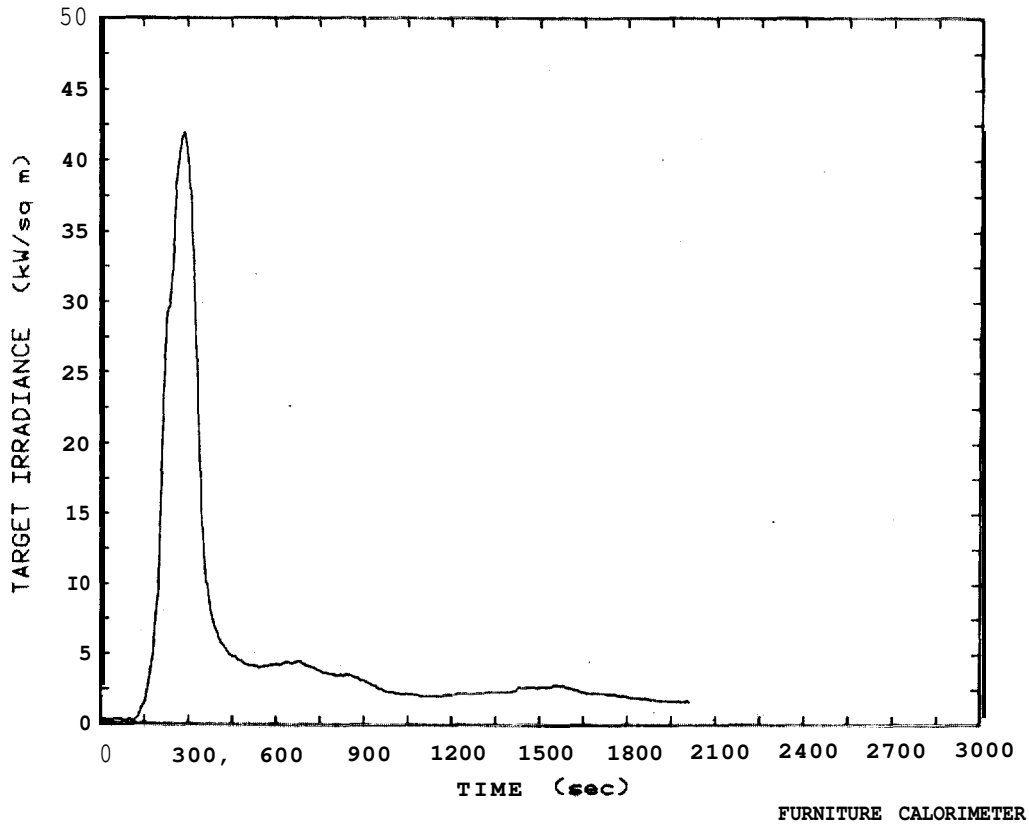

Figure 5: Target irradiance plot for easy chair, Test 45

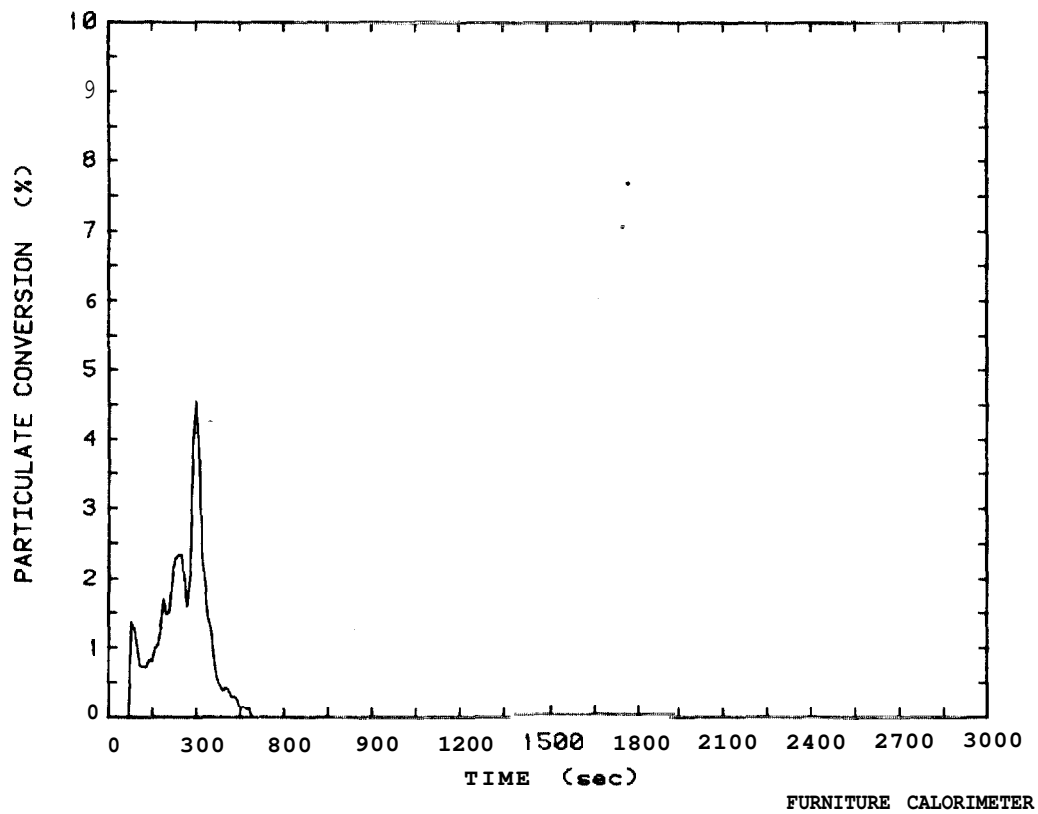

Figure 6: Smoke particulate conversion plot for Test 45

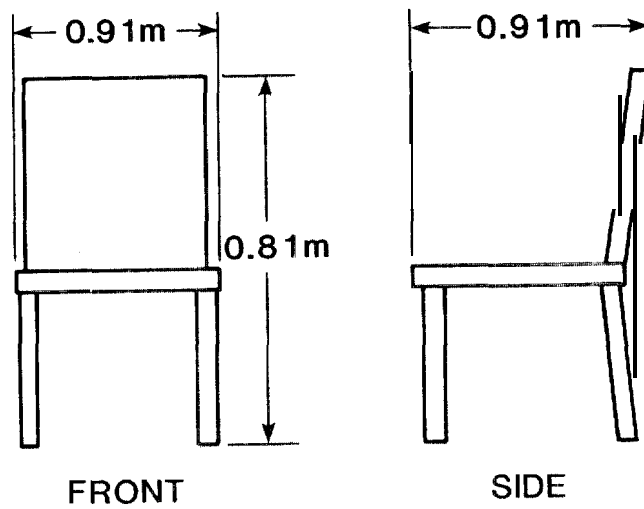

Figure 7 Photograph and dimensions of easy chair with foam cushions, test 48

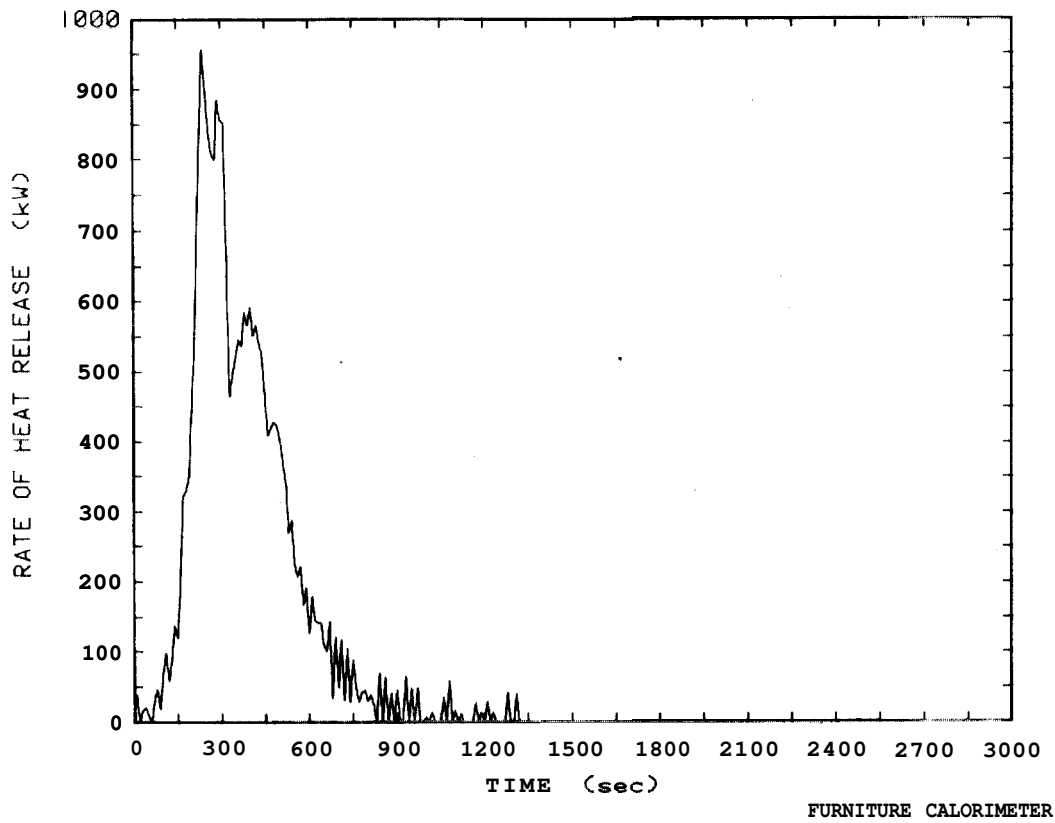

Figure 8: Rate of heat release plot for easy chair, Test 48

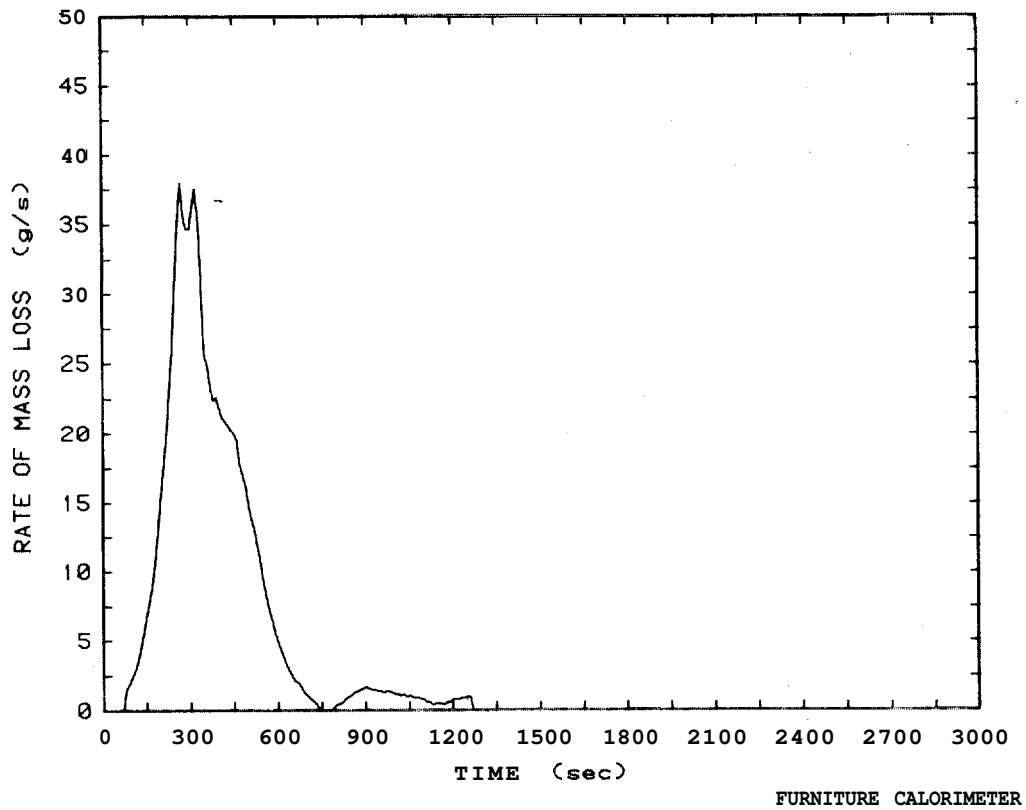
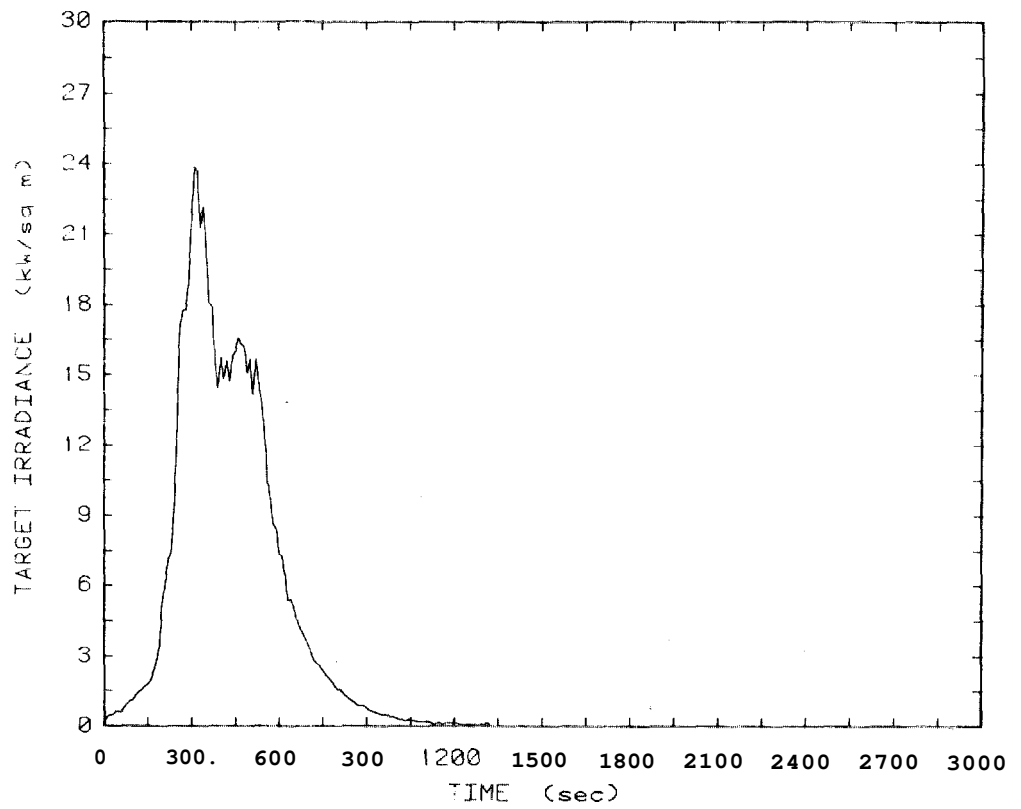
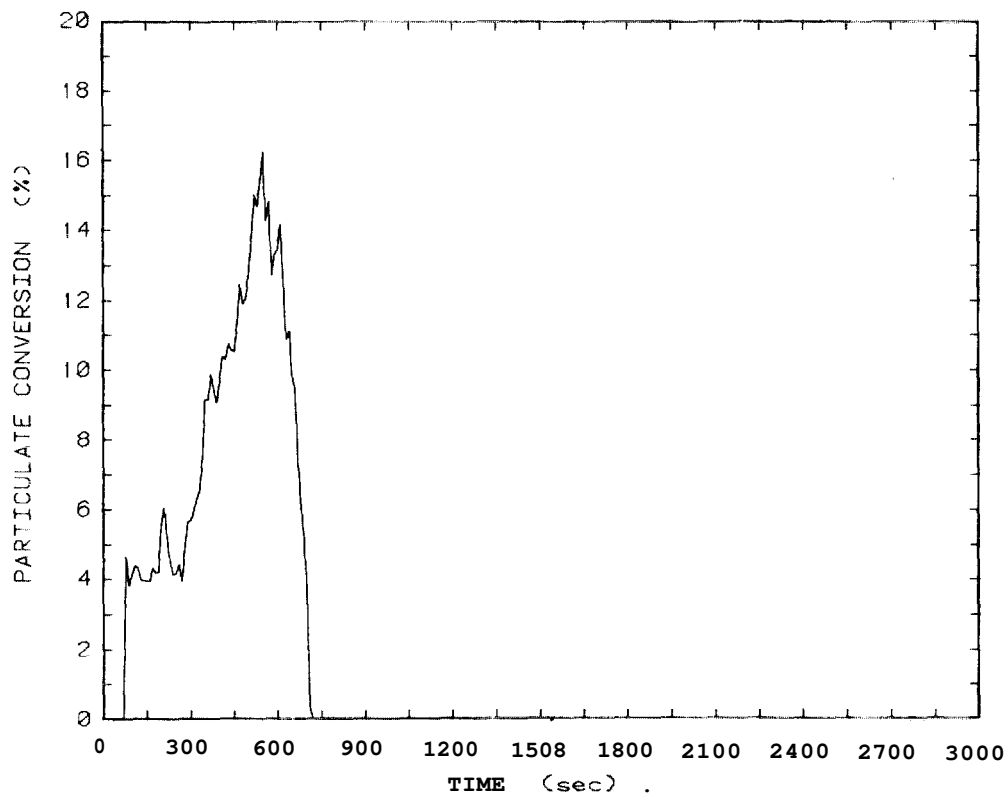

Figure 9: Rate of mass loss plot for easy chair, Test 48



FURNITURE CALORIMETER

Figure 10: Target irradiance plot for easy chair, Test 48



FURNITURE CALORIMETER

Figure 11: Smoke particulate conversion plot for Test 48

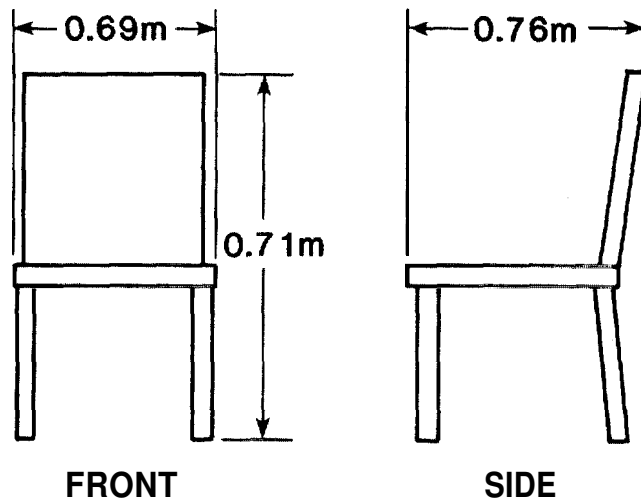
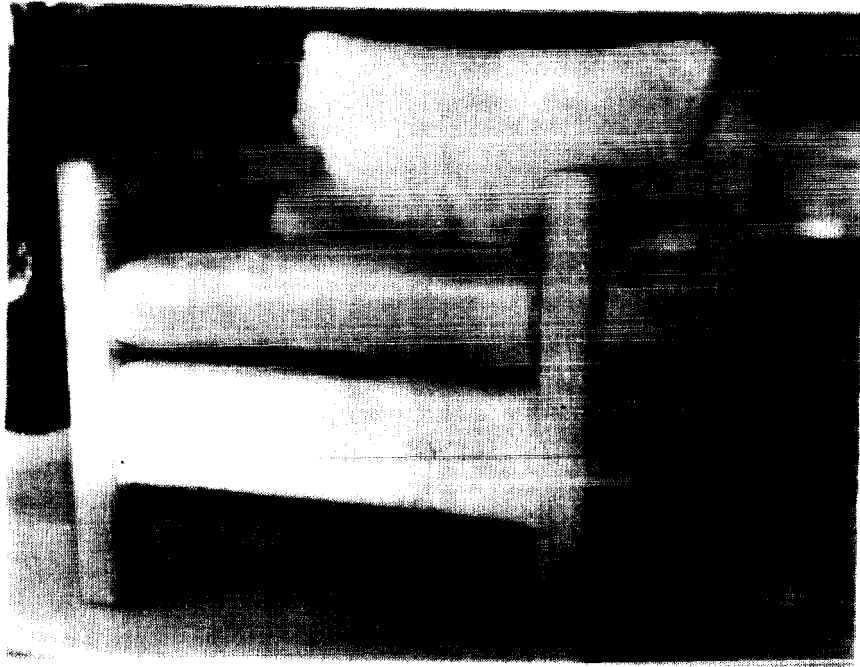

Figure 12. Photograph and dimensions of easy chair with foam cushions, test 49

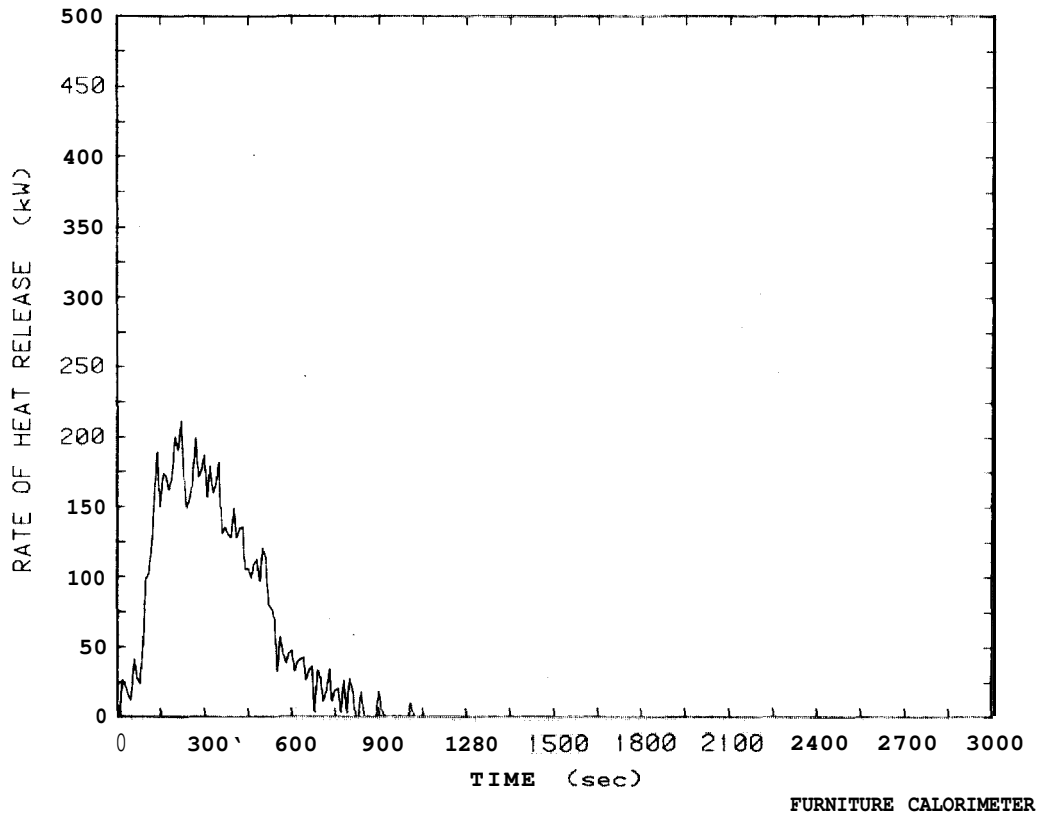

Figure 13. Rate of heat release plot for easy chair Test 49

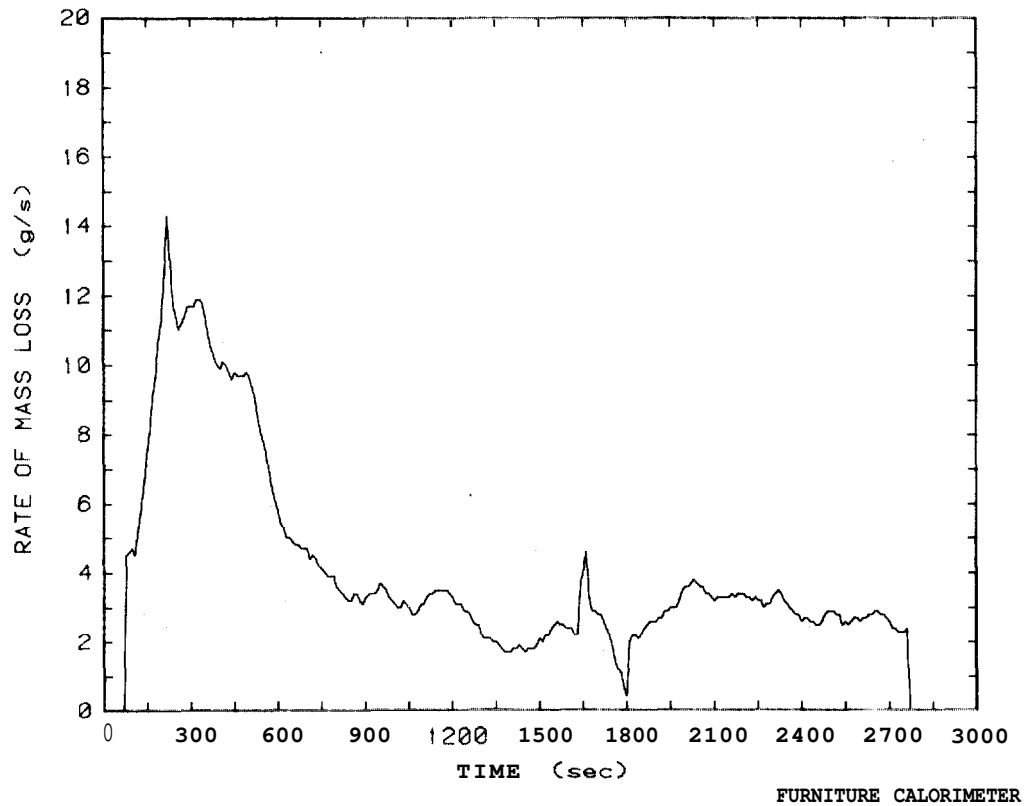

Figure 14. Rate of mass loss plot for easy chair Test 49

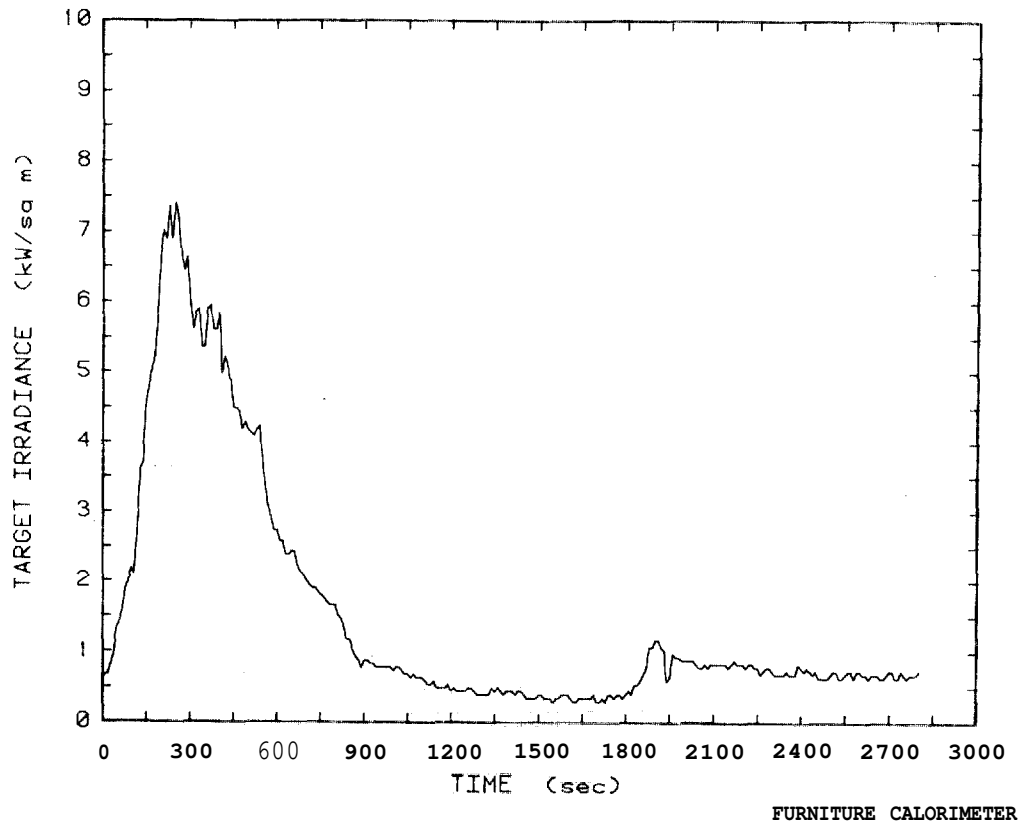

Figure 15. Target irradiance plot for easy chair Test 49

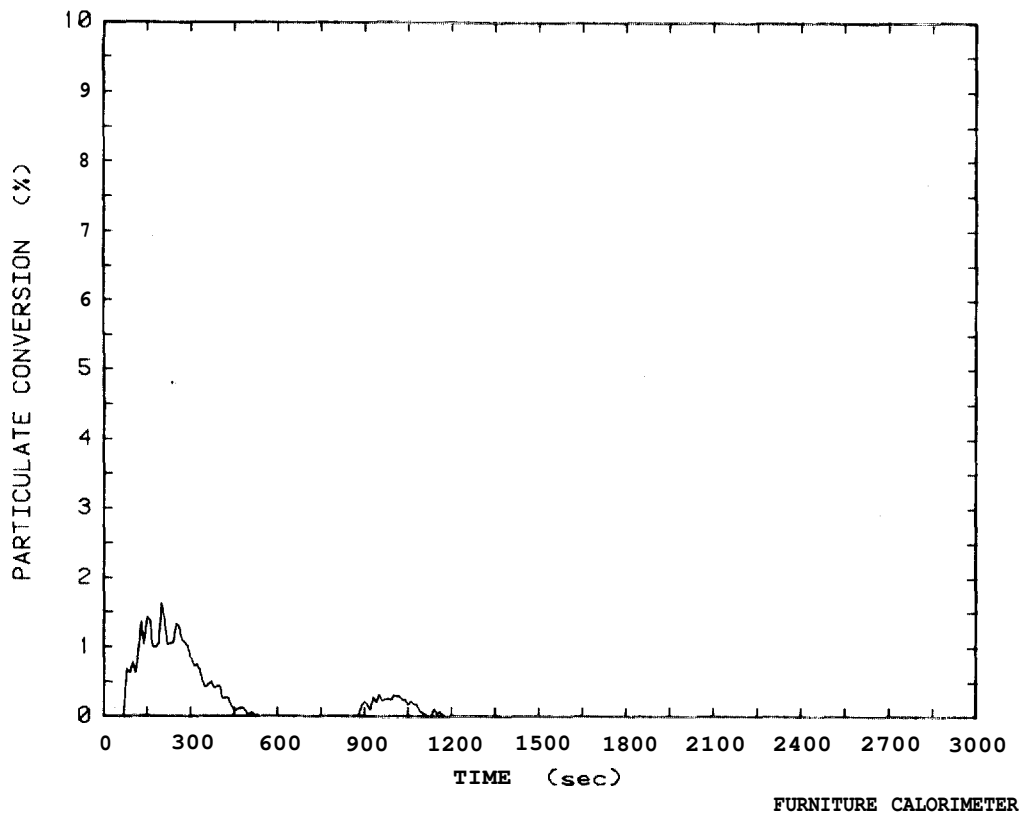

Figure 16. Smoke particulate conversion plot for easy chair Test 49

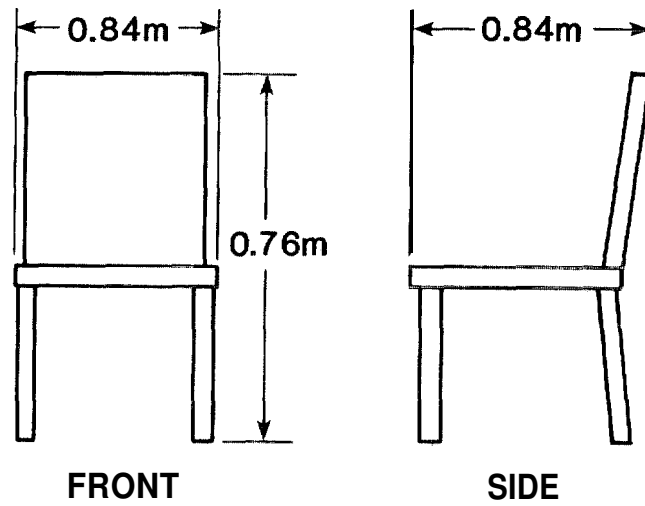

Figure 17. Photograph and dimensions of easy chair, molded flexible urethane frame, test 64

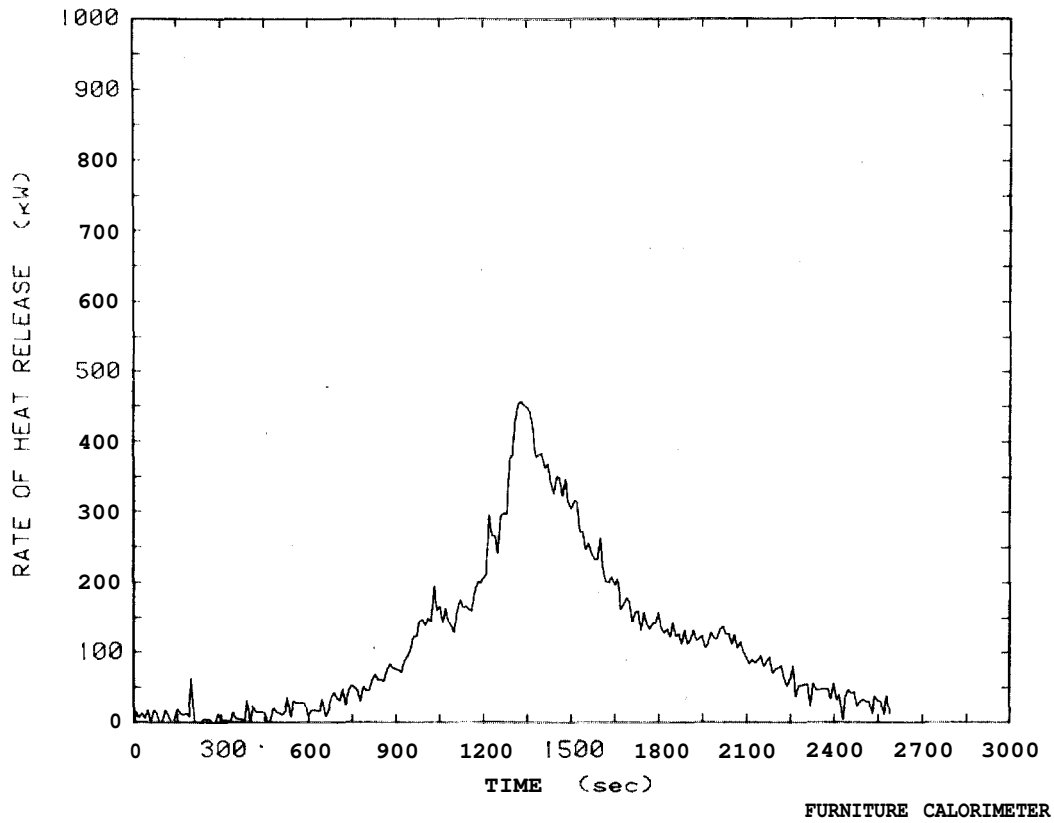

Figure 18. Rate of heat release plot for easy chair Test 64

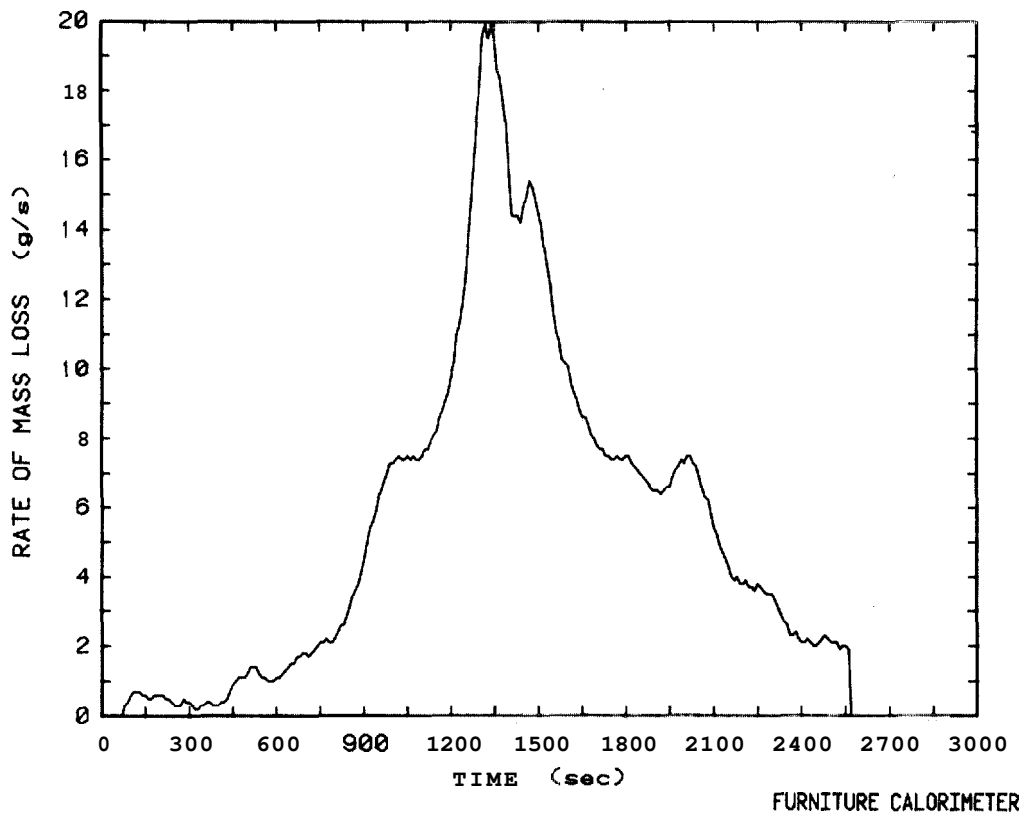

Figure 19. Rate of mass loss plot for easy chair Test 64

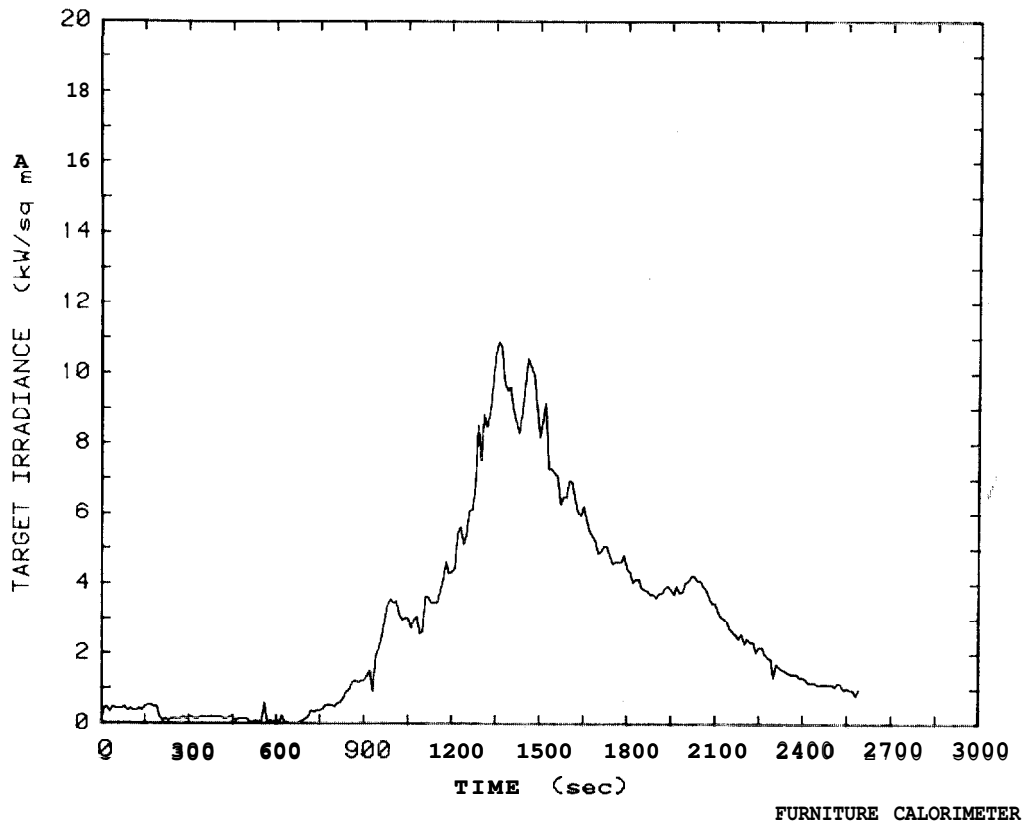

Figure 20. Target irradiance plot for easy chair Test 64

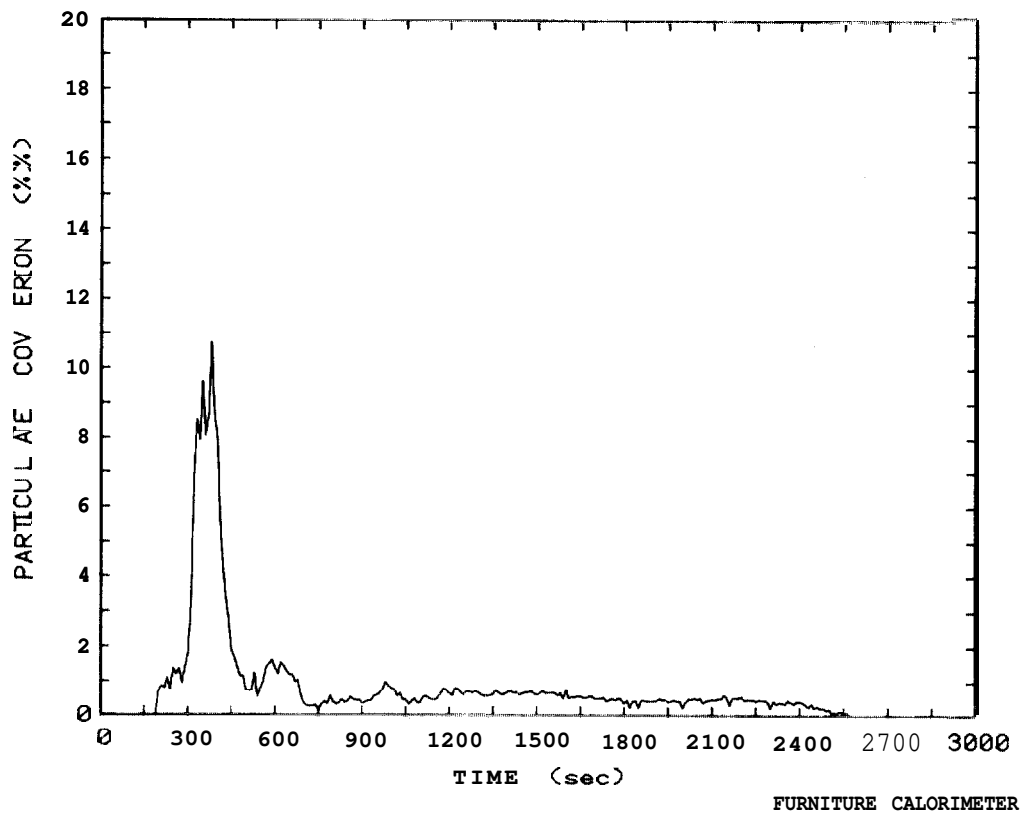

Figure 21. Smoke particulate conversion plot for easy chair Test 64

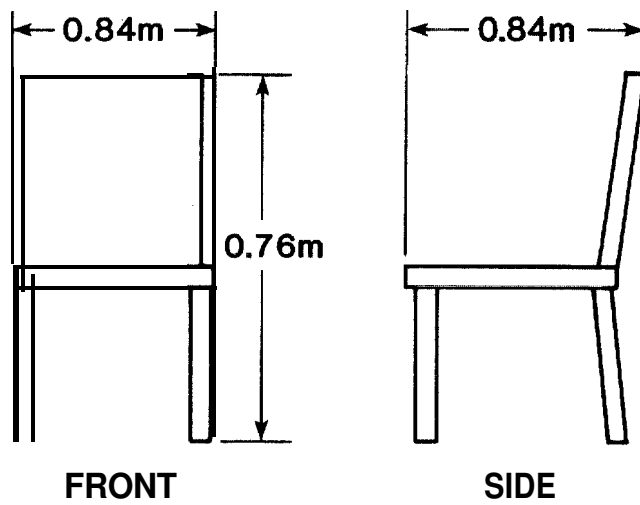
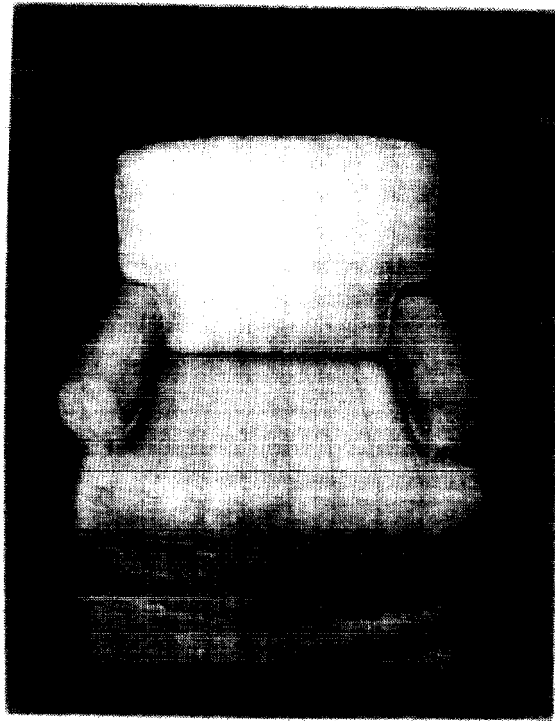

Figure 22. Photograph and dimensions of easy chair, cigarette ignition, test 66

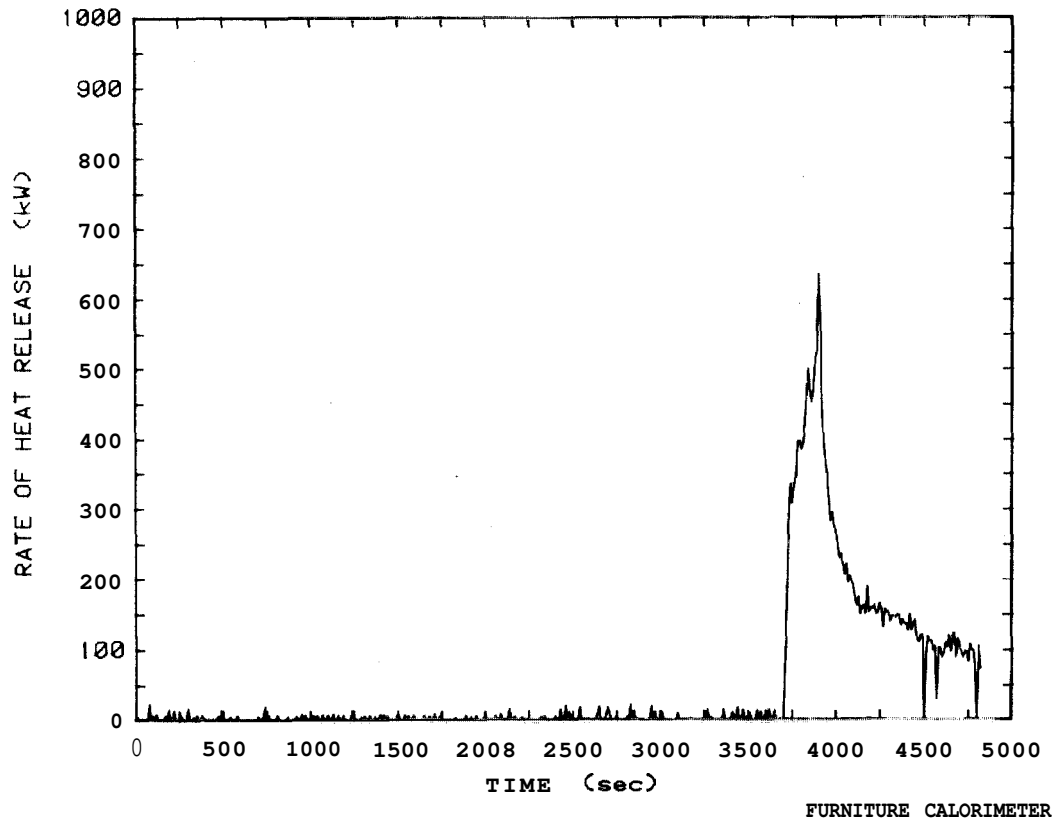

Figure 23: Rate of heat release plot for easy chair Test 66

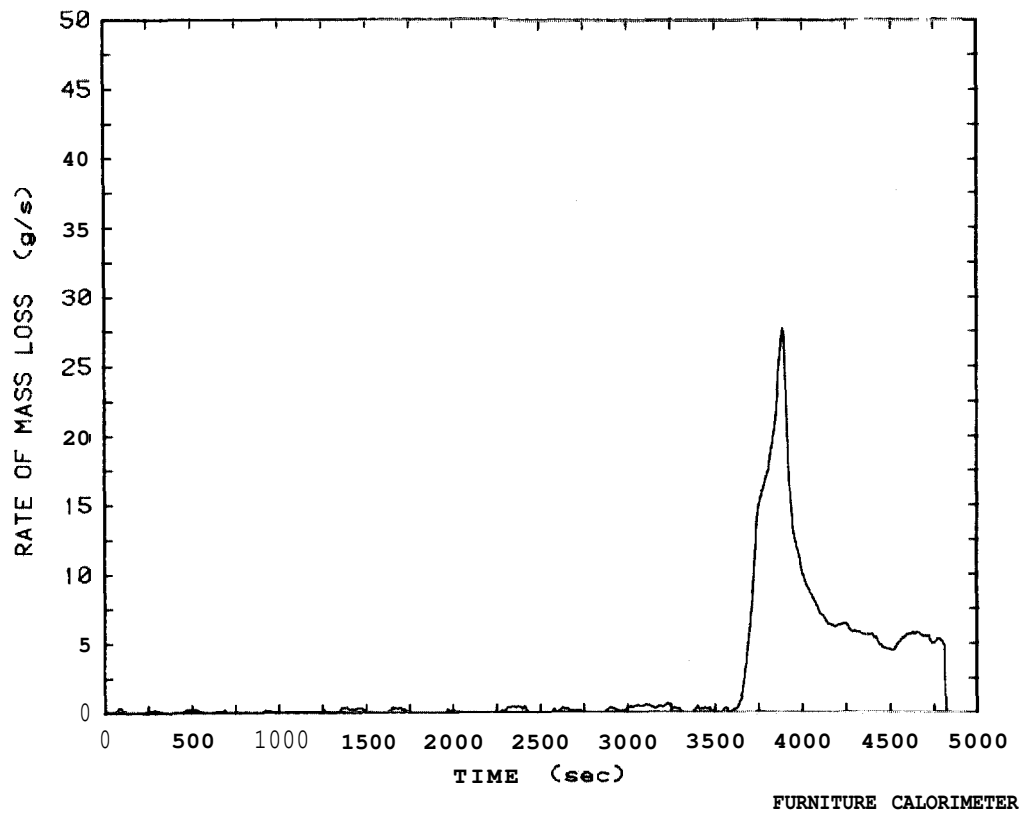

Figure 24: Rate of mass loss plot for easy chair Test 66

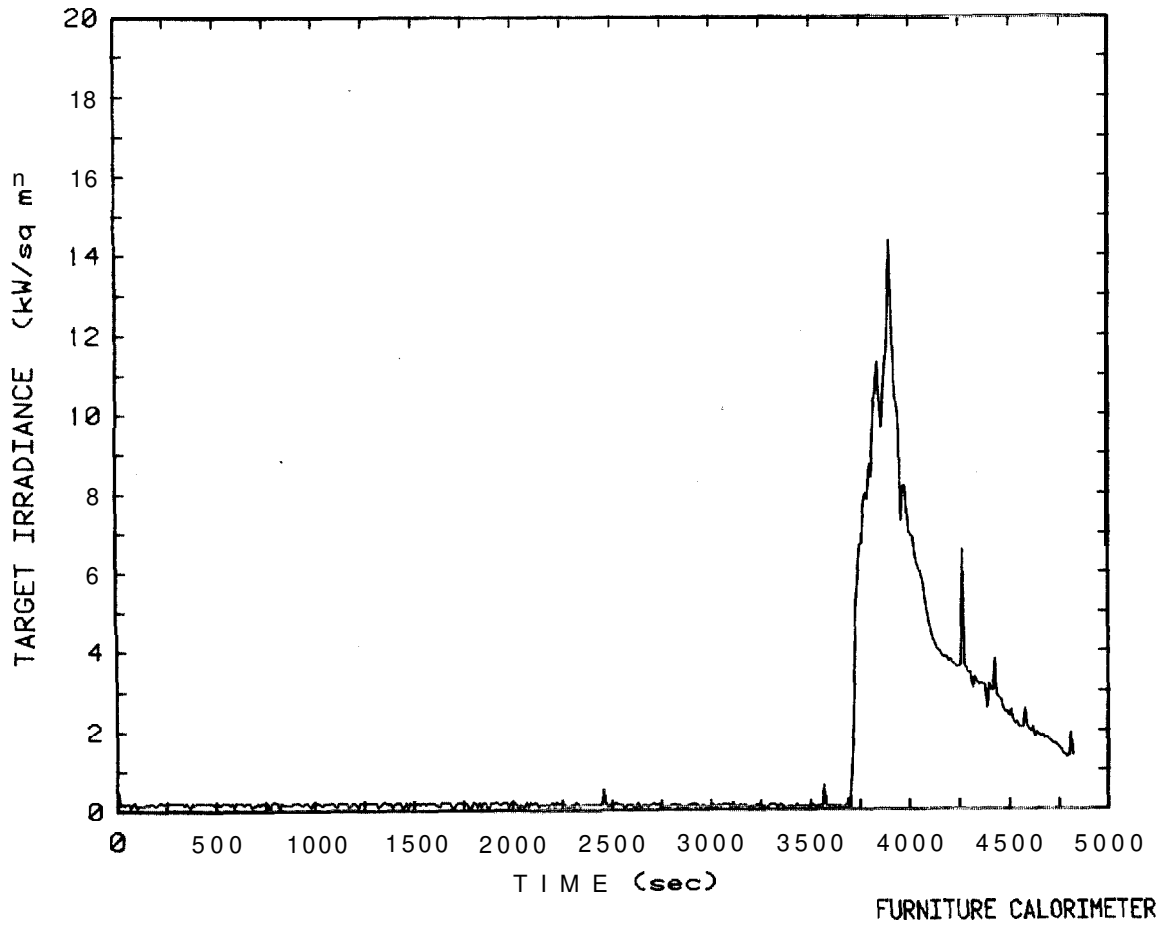

Figure 25. Target irradiance plot for easy chair Test 66

5. WAITING ROOM AND PATIENT CHAIRS

5.1 Description of Waiting Room and Patient Chairs

Eight different types of chairs are grouped into this furnishings category. Six of the chairs are typically found in waiting rooms and offices. The two remaining chairs are primarily designed to be used by hospital patients. These two chairs are found in tests 47 and 52. Figures showing photographs of these chairs are located with the data plots at the end of section 5.2.

Test 47 - This chair had a metal frame with an adjustable back. The seat and back cushions were filled with solid polyurethane foam and a layer of polyester fiber. The back and seat cushions were both supported by 16 mm particle board. The two arm rests were made of wood and the chair's mass was 20.82 kg. (See figure 26.)

Test 50 - This chair had a metal frame with a vegetable fiber and cotton layered seat and back cushion. The chair was covered with a plastic coated fabric. The arm rests were made of thermosetting plastic and the chair's mass was 16.52 kg. (See figure 31.)

Test 51 - This chair was a one-piece molded glass fiber construction with metal legs attached to the bottom. No padding or cushions were used in this chair and it's mass was 5.28 kg. (See figure 34.)

Test 52 - This chair was a specially designed one-piece molded thermo-plastic chair for use in psychiatric hospital wards. It was believed to be molded from polyethylene plastic. The chair could be used as either a rocking chair or a fixed chair. This was determined by which end of the vertical axis was placed on the floor and the chair's mass was 11.26 kg. (See figure 38.)

Test 53 - This chair had a metal frame with padded seat and back cushions. The cushions were filled with solid polyurethane foam and were attached to 12.7 mm plywood. The cushions were covered with a plastic coated fabric and the chair's total mass was 15.54 kg. (See figure 43.)

Test 55 - This chair consisted of a metal frame with a body form plywood seat and back. The seat and back were padded with thin layers of polyurethane foam and covered with a synthetic fiber fabric. The chair was designed for use with a metal frame capable of supporting several chairs in a group and it's mass was 6.08 kg. (See figure 48.)

Test 56 - This chair was constructed with a wood frame. The seat and back were constructed around 14 mm plywood. The seat cushion was made of 90% latex foam rubber with 10% cotton felt. The back cushion consisted of 100% latex foam rubber. The cushion covers were plastic coated fabric and the chair's mass was 11.20 kg. (See figure 53.)

Test 75 - These chairs were built with metal frames capable of being nested together for stacking. The seats and backs were lightly padded with polyurethane foam and covered with a plastic coated fabric. The seats and back cushions were attached to plywood boards and each chair's mass was 7.49 kg. (See figure 58.)

5.2 Results and Discussion of Waiting Room and Patient Chair Tests

All chairs in this category were ignited using the gas burner and procedure described in section 3.2.2. The first chair studied **in** this group was a metal frame, adjustable back patient chair (test 47). Data on this chair, and other chairs in this group, are found in table 5. Data plots for test 47 are shown in figures 27-30. This chair exhibited two heat release peaks, the larger first peak resulting from the burning polyurethane foam seat and back cushions and the second resulting from the burning particle board seat and back supports. The total heat release was relatively low compared to the easy chairs shown in table 4. In test 50 (figures **31-33**), the metal frame chair was ignited by the gas burner, but the flames did not propagate and went out shortly after the exposure flame was removed. All values measured during this test were very low since the chair did not continue to burn. The target irradiance shown in figure 33 resulted from the exposure flame of the gas burner.

The molded fiberglass chair evaluated in test 51 also gave low values. See figures 35-37. It ignited and flames slowly propagated across the surface of one arm and across part of the back. The heat release rate shown in figure 35 exhibits several peaks as a result of the slow and erratic burning. The maximum peak heat release rate occurred while the chair was still receiving energy from the exposure flame.

One of the most interesting chairs studied in this project was examined in test 52. See figures 39-42. This molded plastic patient chair was ignited easily, burned at a very slow rate for over 1900 seconds, became a pool of

melted plastic and burned rapidly once the pool was established. This chair also exhibited the highest average heat of combustion. The chair in test 53 produced the second highest peak heat release rate of this furniture group. See figures 44-47.

The group chair shown in results from test 55 performed well. Test results are seen in figures 49-52. The peak heat release rate was the lowest in this furniture group. The peak target irradiance was also low. This is much smaller than that shown in earlier tests that had low heat release rates. This low value resulted from the chair deflecting the exposure flame away from the radiometer where other chair shapes caused the flame to pass closer to the radiometer.

The chair in test 56 had a peak heat release rate slightly above that provided by the ignition source as shown in figures 54-57. However, the chair had the largest peak particulate conversion for smoke in this group of furniture. In test 75, the four stacked chairs had a total heat release which was the second highest for this class of furniture. The results for this test are shown in figures 59-62. The early peak in heat release rate, as seen in figure 59, occurred with the burning polyurethane foam cushions. This is also seen in figure 62 where the peak particulate conversion took place. The chairs burned for a total of 2230 seconds as a result of the plywood seat and back boards.

Table 5. Test Results on Waiting Room and Patient Chairs

Item	Test No.	Specimen Mass (kg)	Heat Release Rate (kW)		Total Heat Release (MJ)	Peak Mass Loss Rate (g/s)	Average Heat of Combustion (MJ/kg)	Peak Target Irradiance (kW/M ²)	Smoke Peak Particulate Conversion (%)	Total Smoke Produced (g)	Peak Carbon Monoxide (g/s)
			Initial Peak	Secondary Peak							
Adjustable Back, Metal Frame Patient Chair	47	20.82	240	110	36	10.2	21.8	6.0	5.3	48	0.4
Metal Frame, Minimum Cushion	50	16.52	3	N	< 0.1	(1)	(1)	(2)	(1)	(1)	0.0
Molded Fiberglass, No Cushion	51	5.28	30	30	2	1.3	26.2	1.9 ⁽²⁾	(3)	(3)	0.3
Molded Plastic Patient Chair No Cushion	52	11.26	140	790	350	25.2	34.1	12.3	9.1	400	0.5
Metal Frame with Foam Cushions	53	15.54	270	290	41	13.1	21.4	1.7	6.5	101	1.1
Group Chair, Metal Frame, Foam Cushion	55	6.08	10	10	1	0.6	19.2	0.2	2.9	1.0	0.0
Wood Frame, Latex Foam Cushion	56	11.20	80	50	12	3.1	16.5	0.6	14.3	48	0.3
Metal Frame, Chairs, Stacked 4 High	75	29.94	160	N	191	7.2	18.7	4.7	4.3	116	0.3

N - No second peak.

(1) - Data not available because mass loss, irradiance and smoke were too small to measure.

(2) - Exposure flame was burning during time peak was measured.

(3) - Data not available as a result of instrument failure.

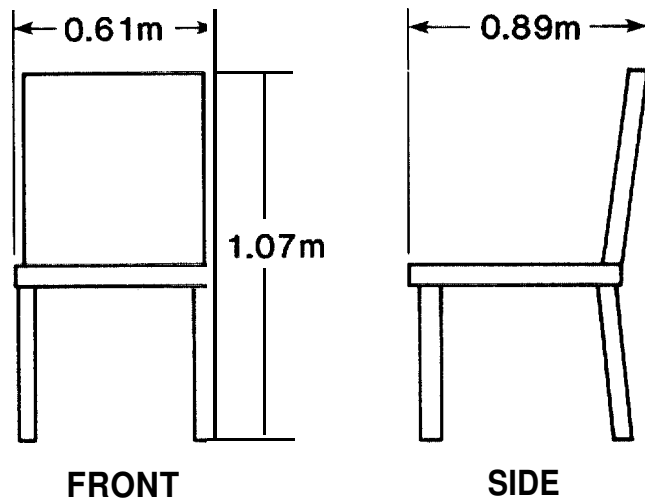

Figure 26. Photograph and dimensions of adjustable back patient chair, test 47

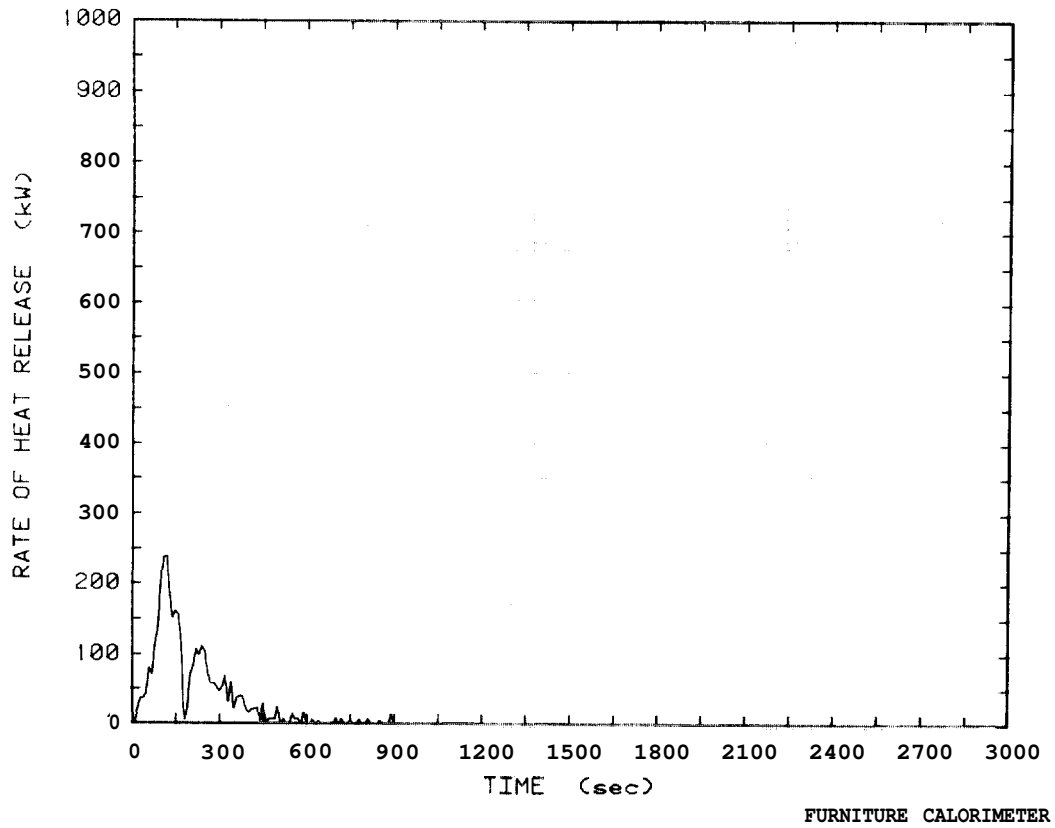

Figure 27: Rate of heat release plot for patient chair Test 47

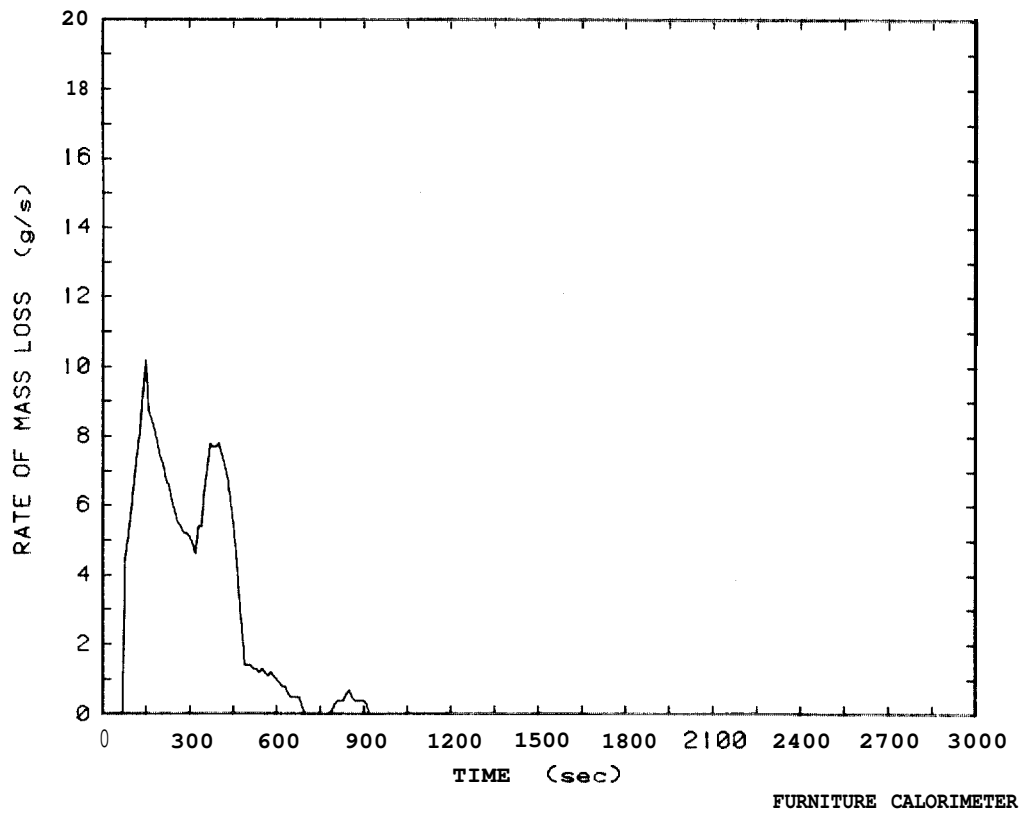

Figure 28: Rate of mass loss plot for patient chair Test 47

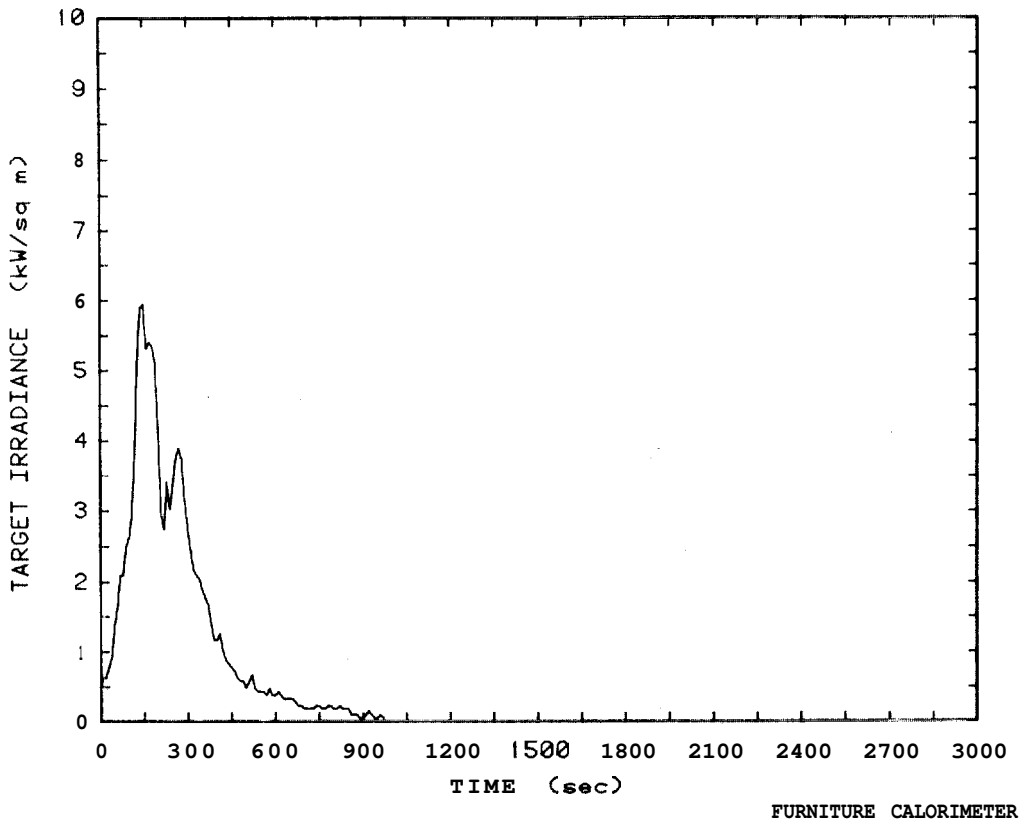

Figure 29: Target irradiance plot for patient chair Test 47

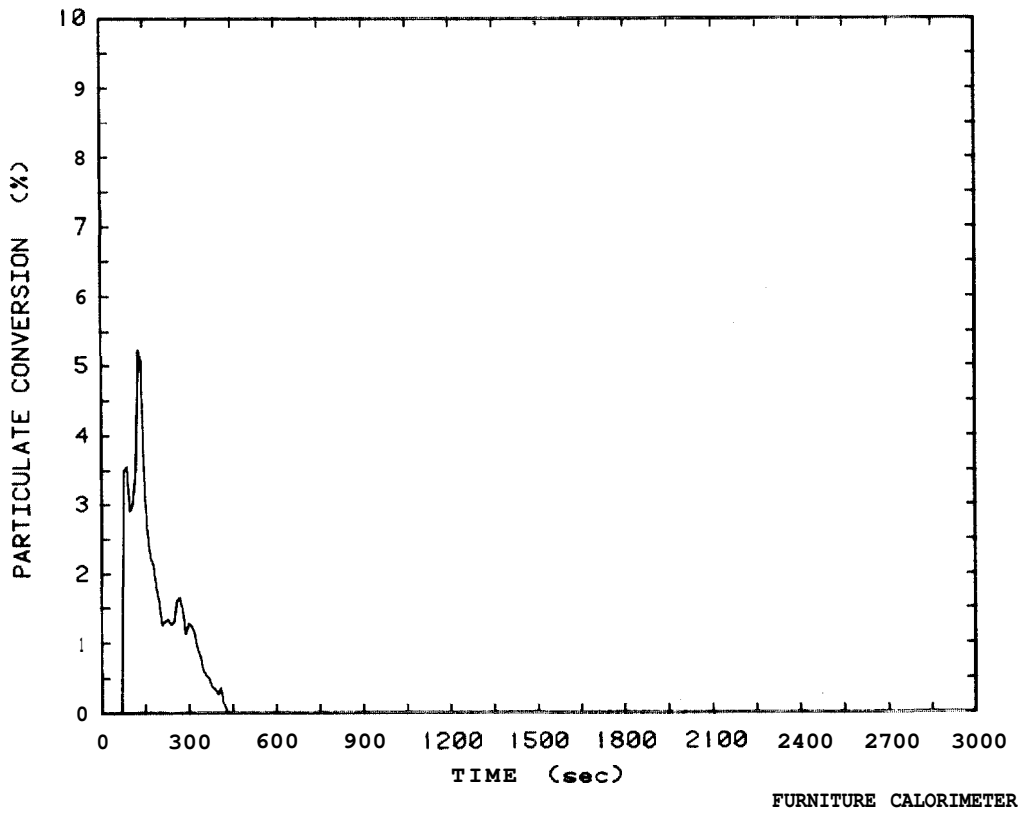

Figure 30: Smoke particulate conversion plot for patient chair Test 47

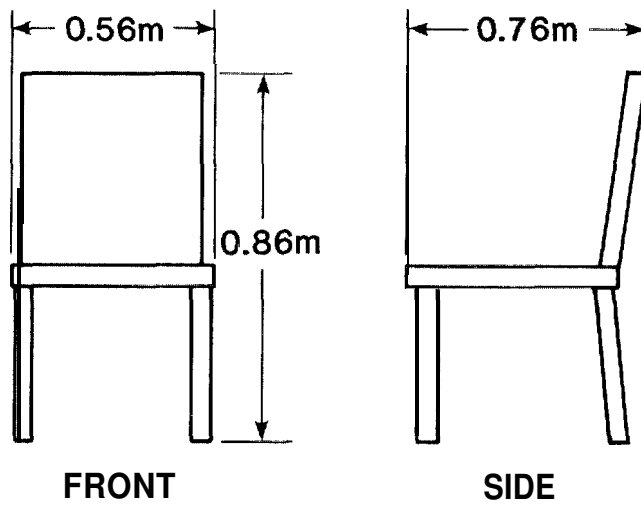
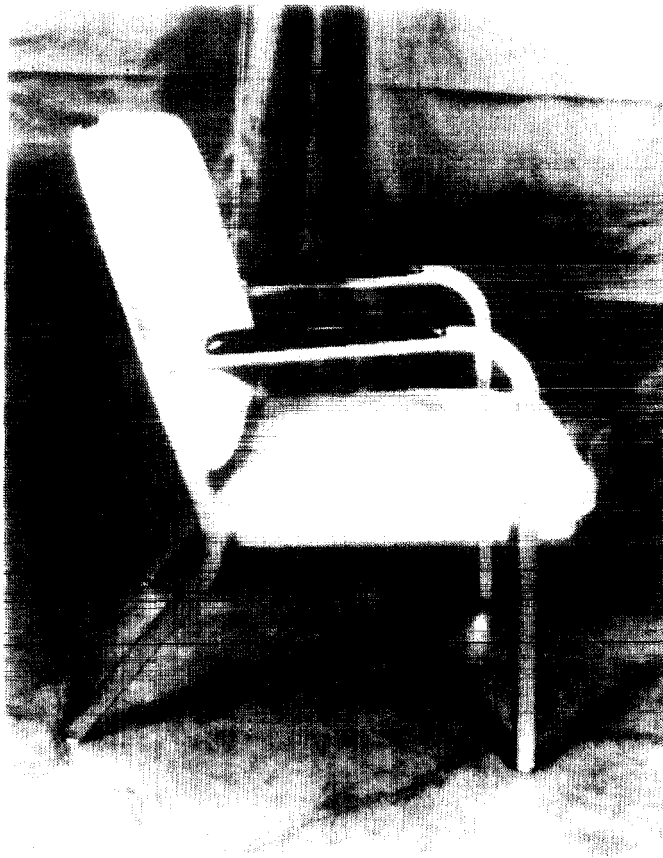

Figure 31. Photograph and dimensions of minimum cushion chair, test 50

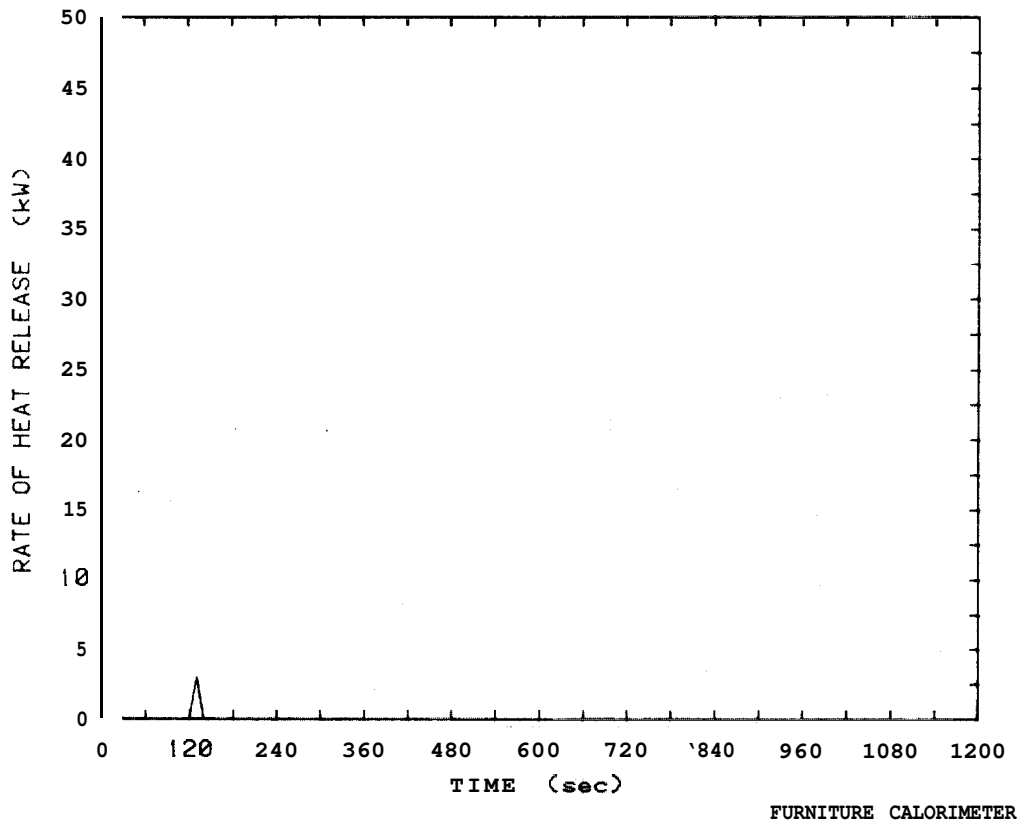

Figure 32: Rate of heat release plot for minimum cushion chair, Test 50

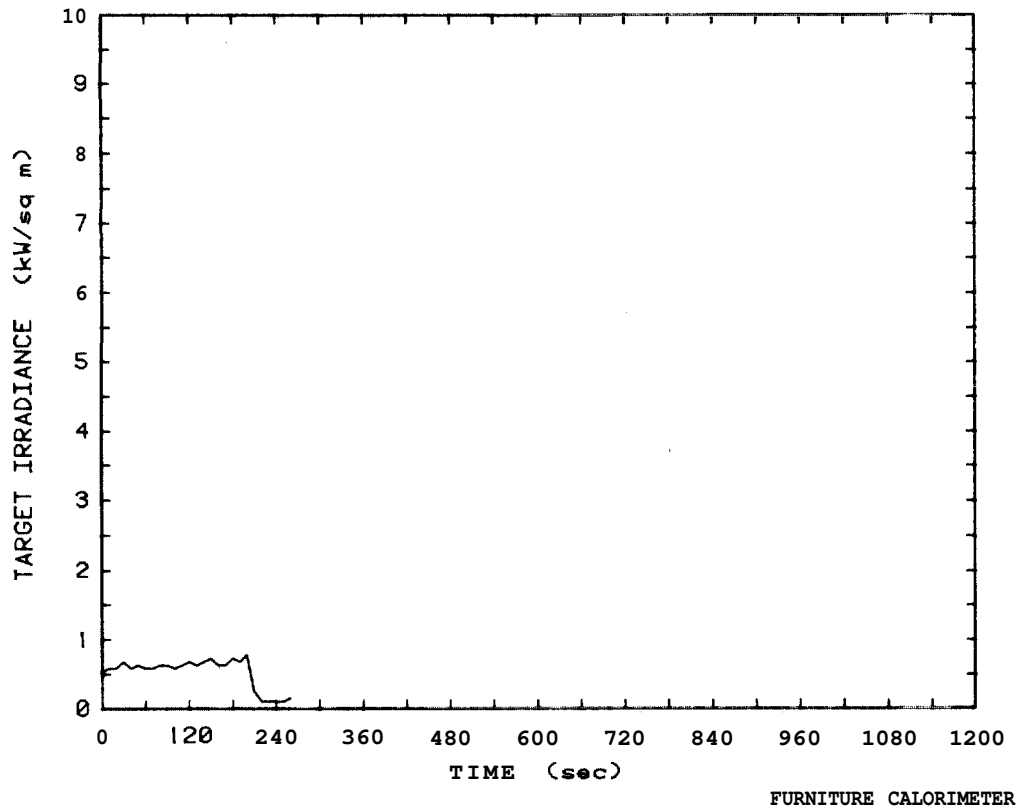

Figure 33: Target irradiance plot for minimum cushion chair, Test 50

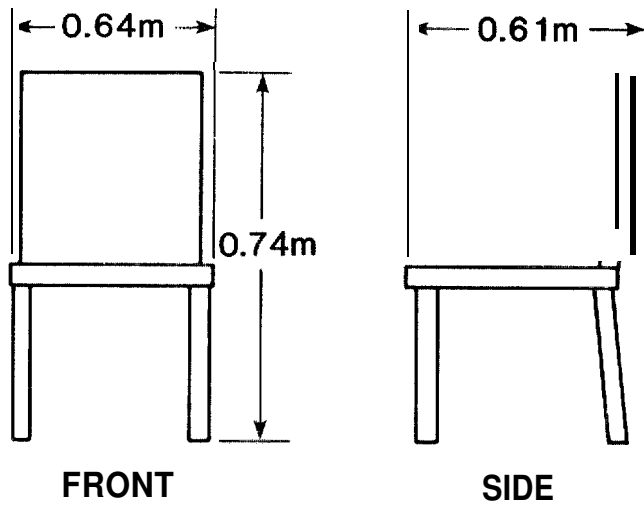
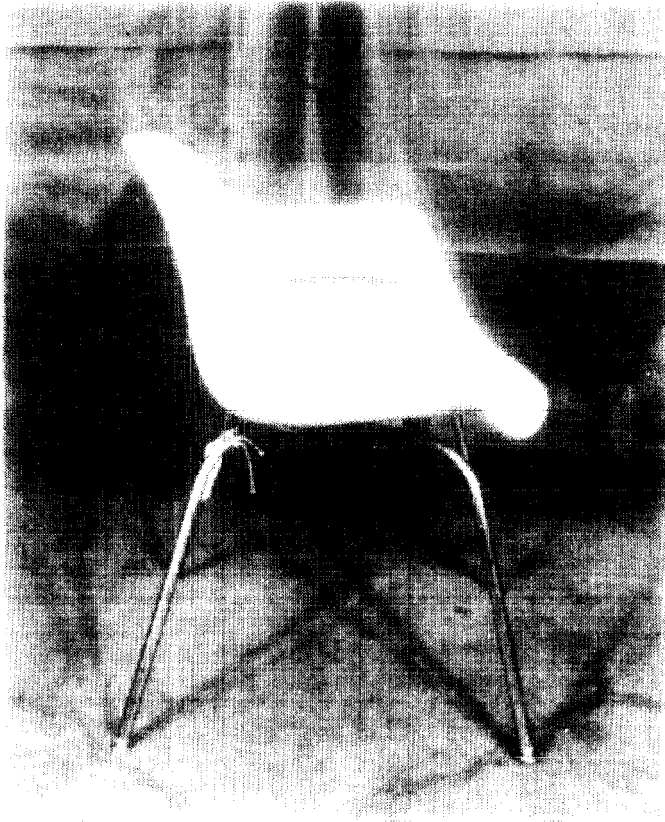

Figure 34. Photograph and dimensions of molded fiberglass chair, test 51

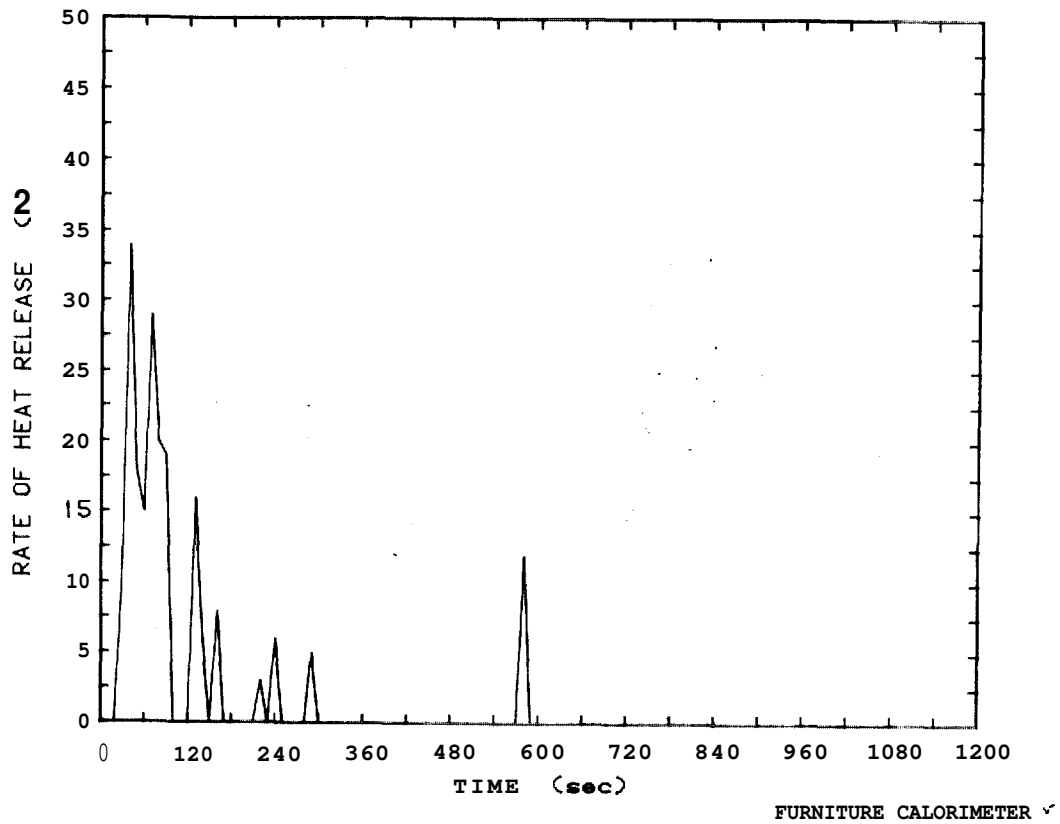

Figure 35: Rate of heat release plot for molded fiberglass chair, Test 51

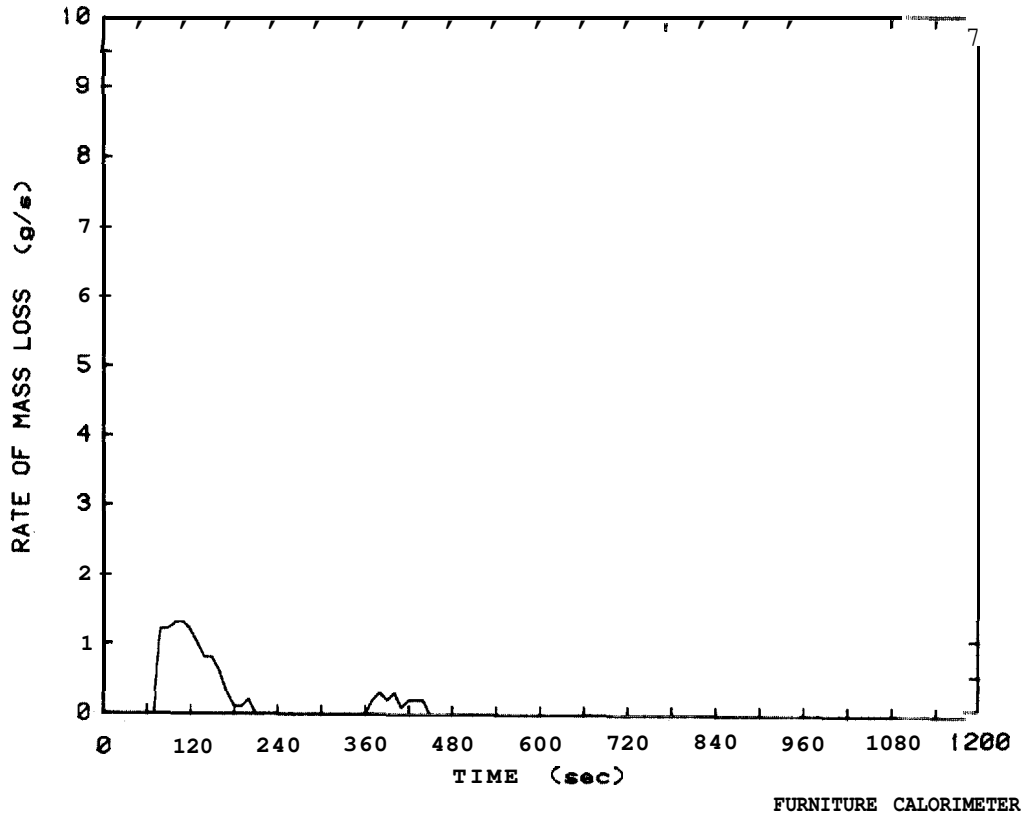

Figure 36: Rate of mass loss plot for molded fiberglass chair, Test 51

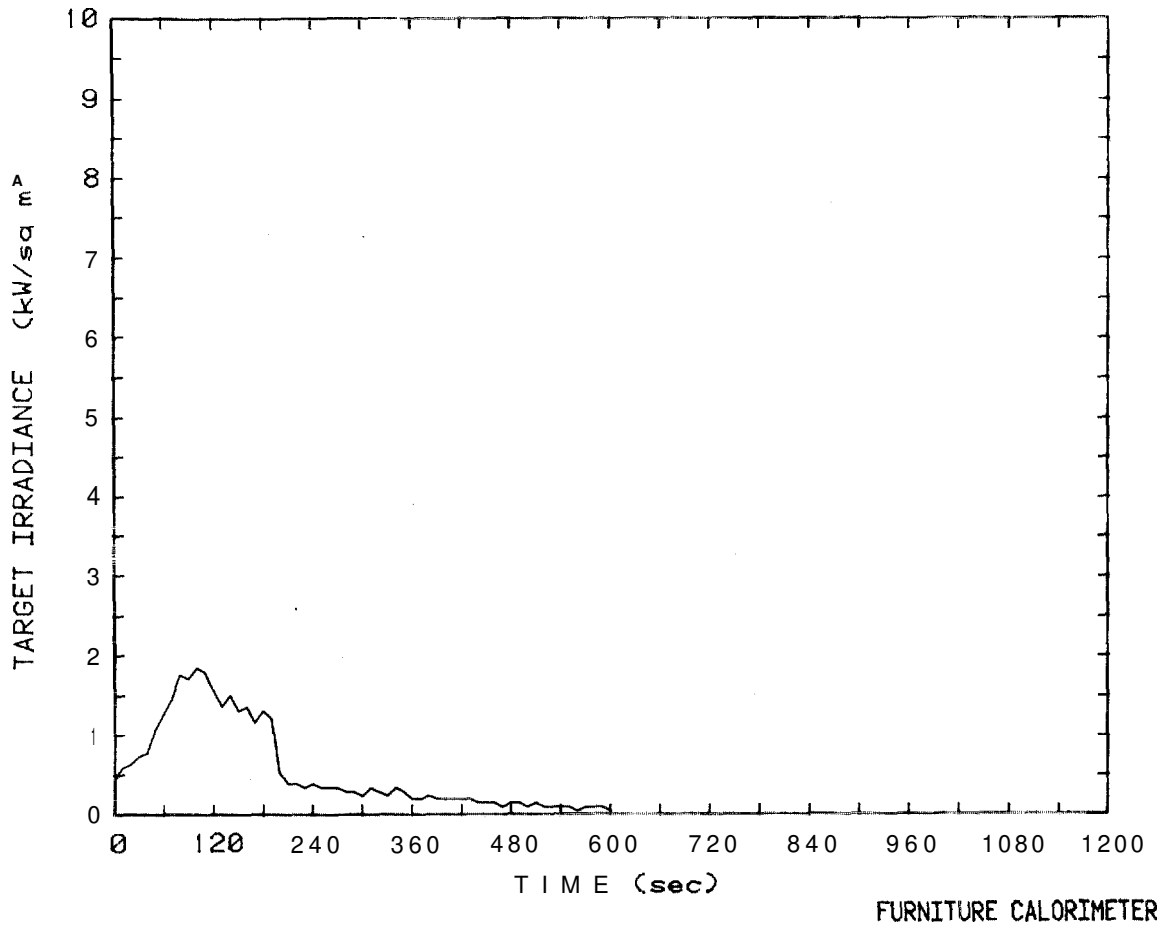

Figure 37. Target irradiance plot for molded fiberglass chair
Test 51

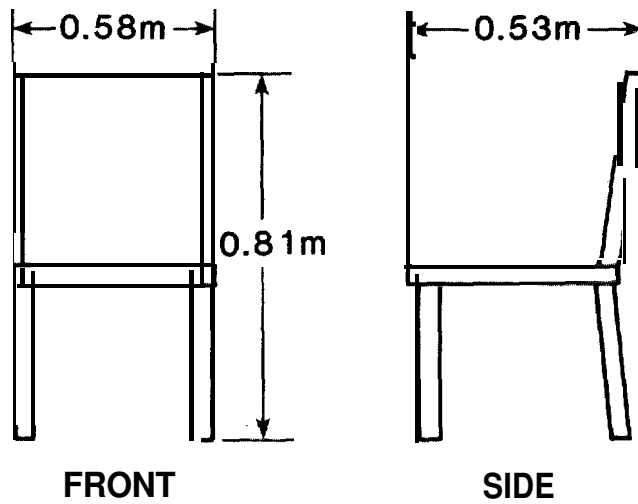
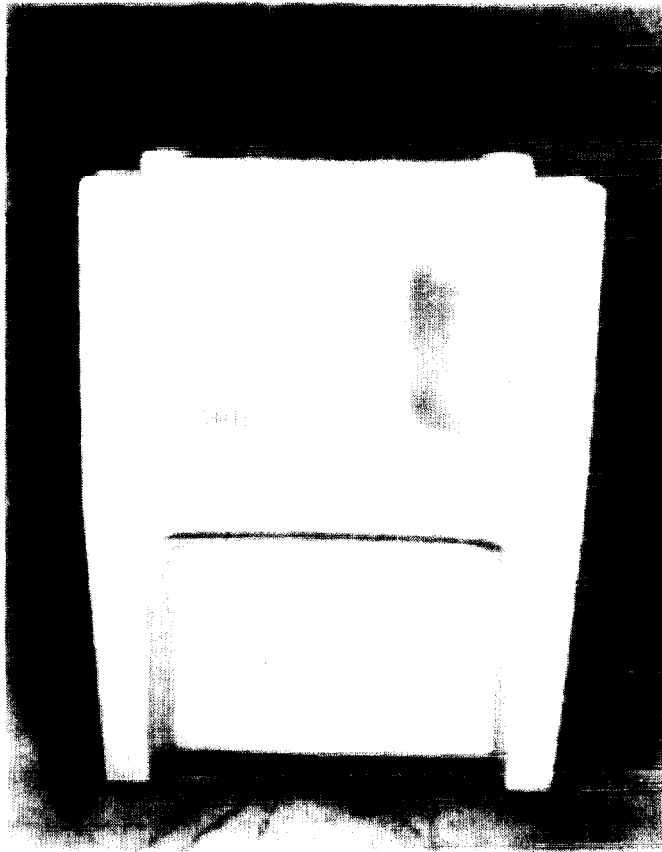

Figure 38. Photograph and dimensions of molded plastic patient chair, test 52

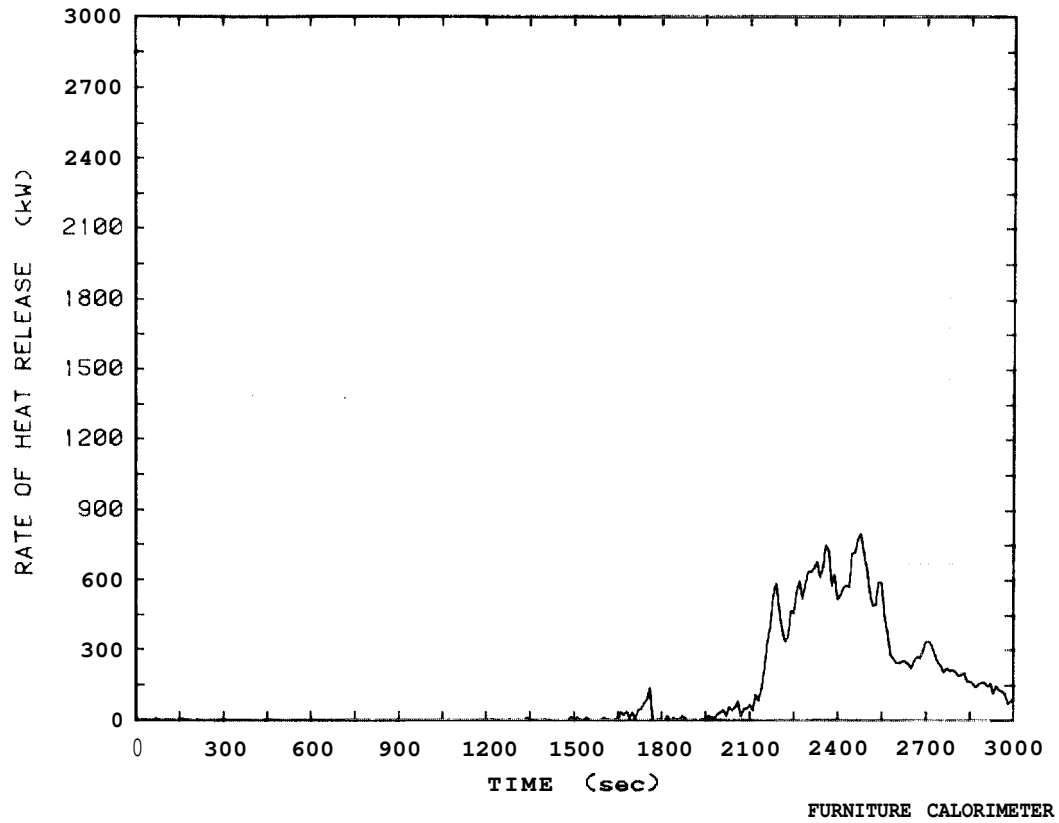

Figure 39: Rate of heat release plot for molded plastic patient chair, Test 52

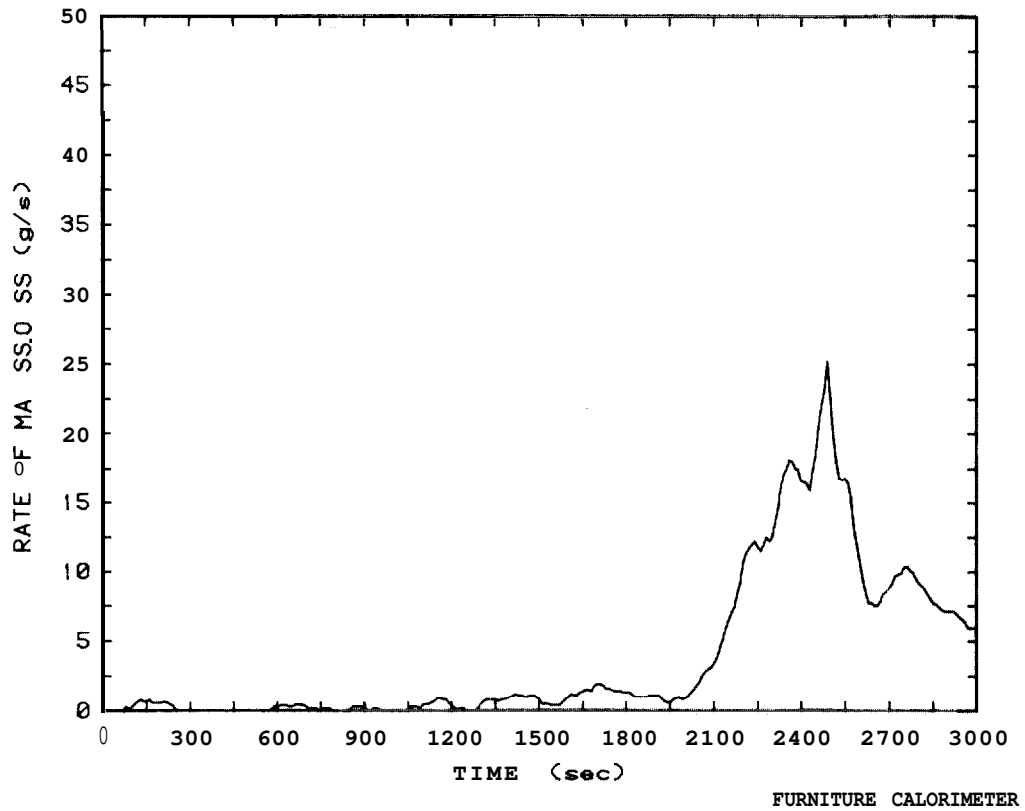

Figure 40: Rate of mass loss plot for molded plastic patient chair, Test 52

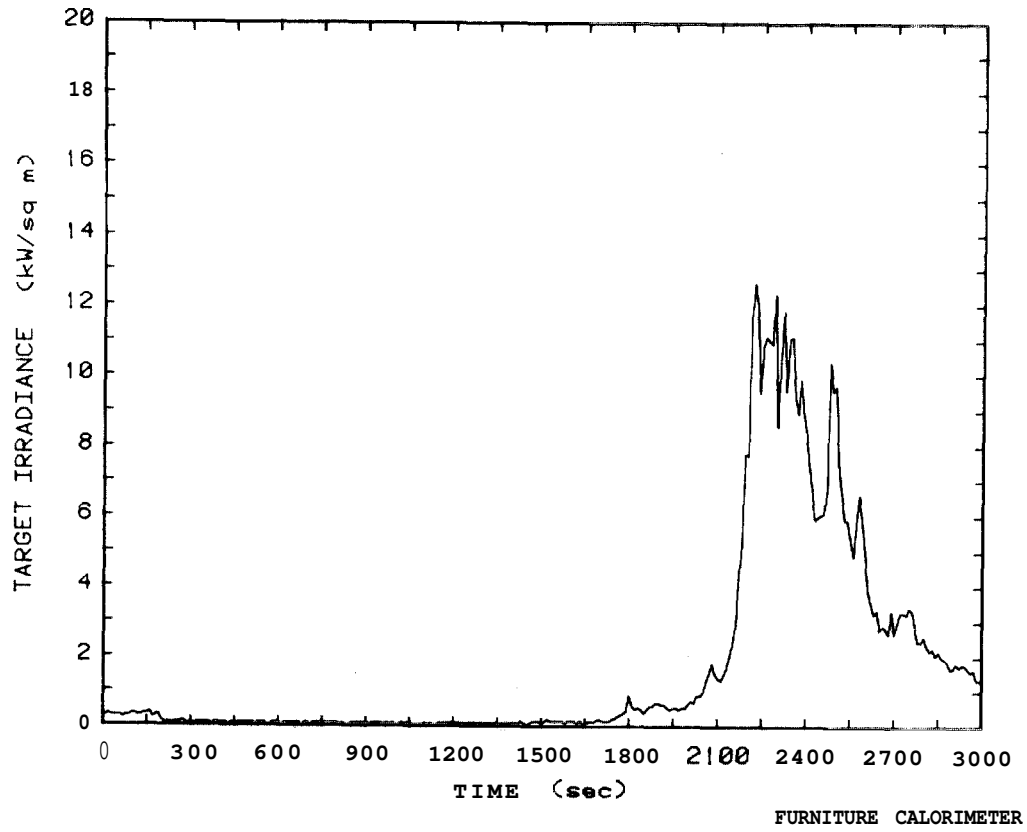

Figure 41: Target irradiance plot for molded plastic patient chair, Test 52

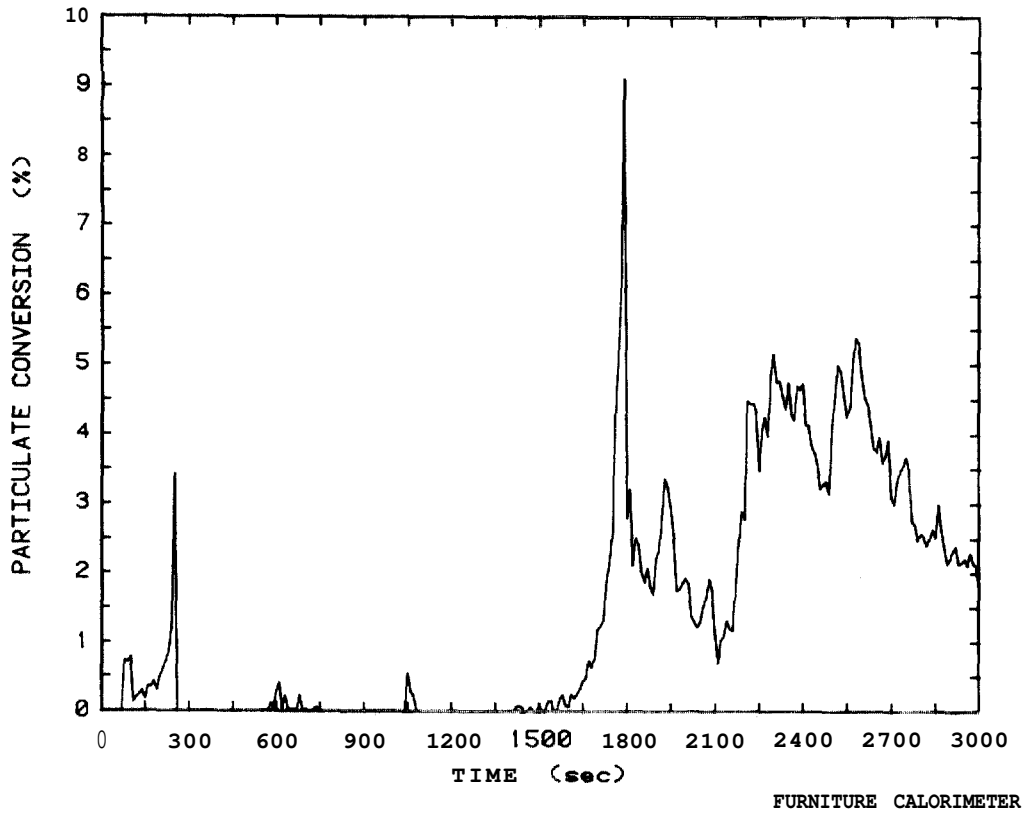

Figure 42: Smoke particulate conversion plot for molded plastic patient chair, Test 52

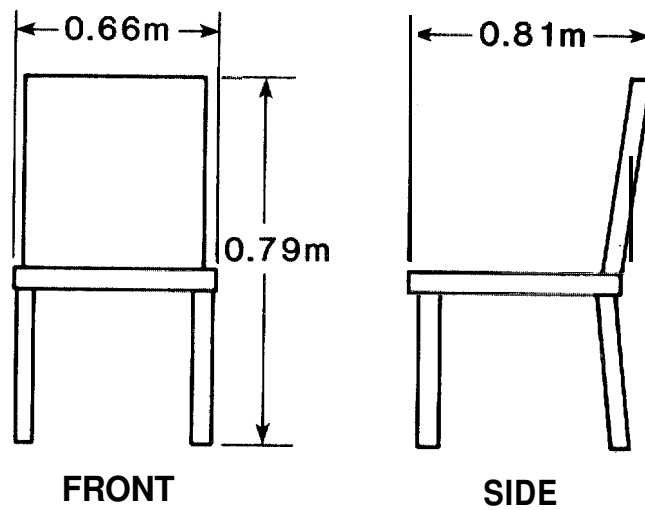
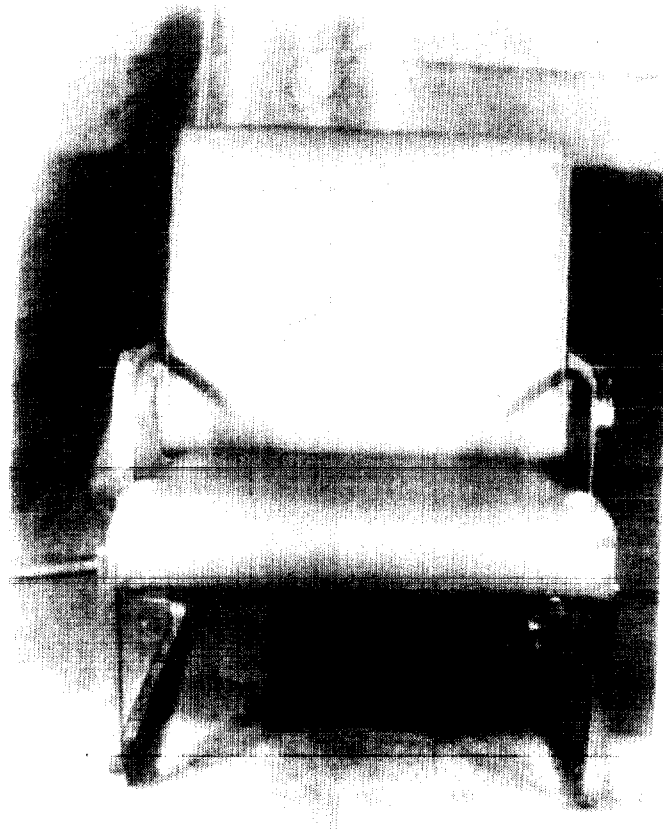

Figure 43. Photograph and dimensions of metal frame chair, test 53

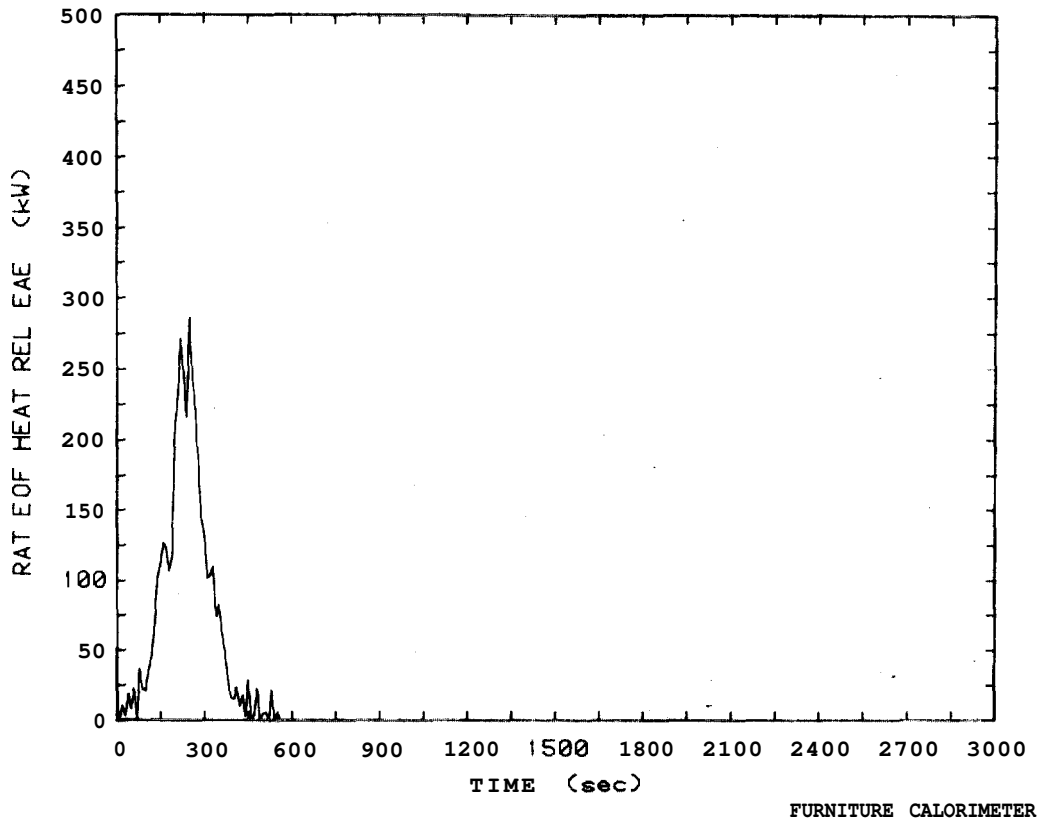

Figure 44: Rate of heat release plot for metal frame chair, Test 53

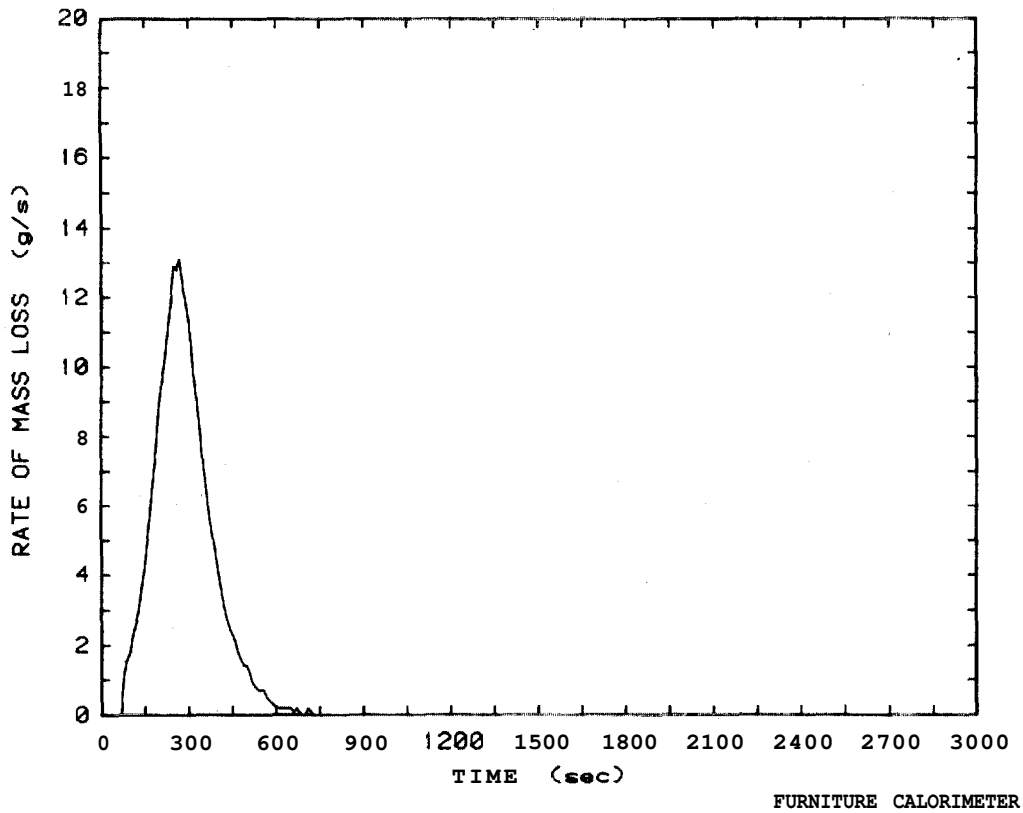

Figure 45: Rate of mass loss plot for metal frame chair, Test 53

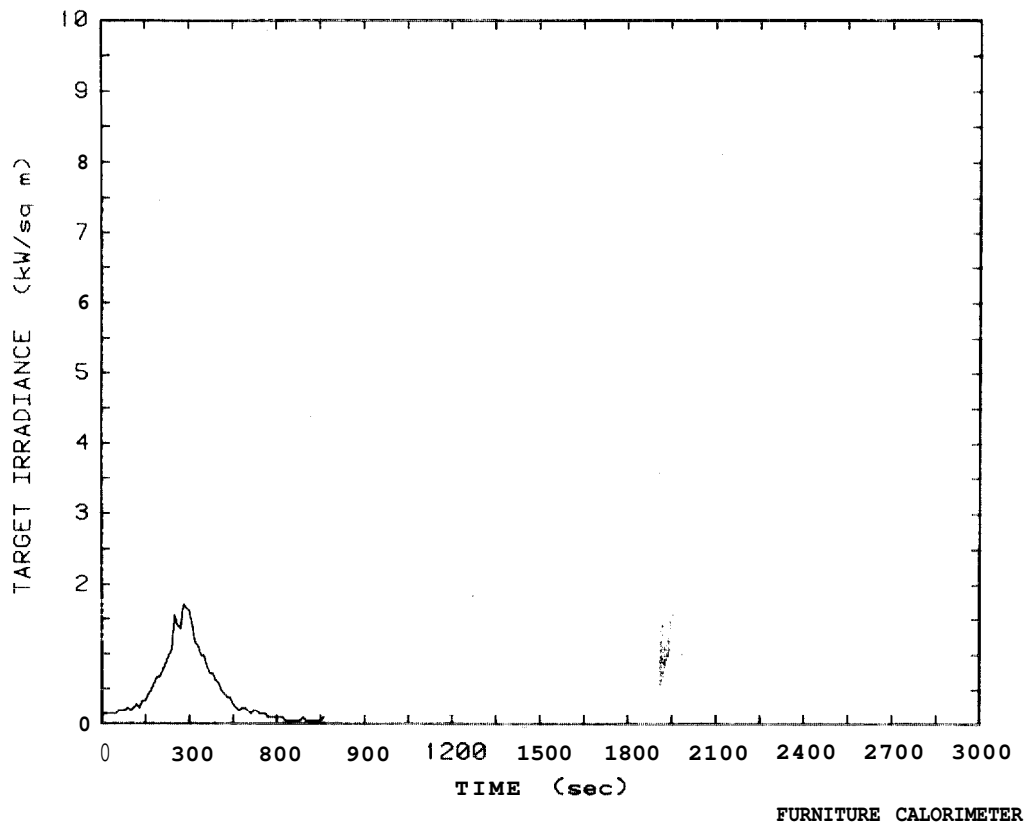

Figure 46: Target irradiance plot for metal frame chair, Test 53

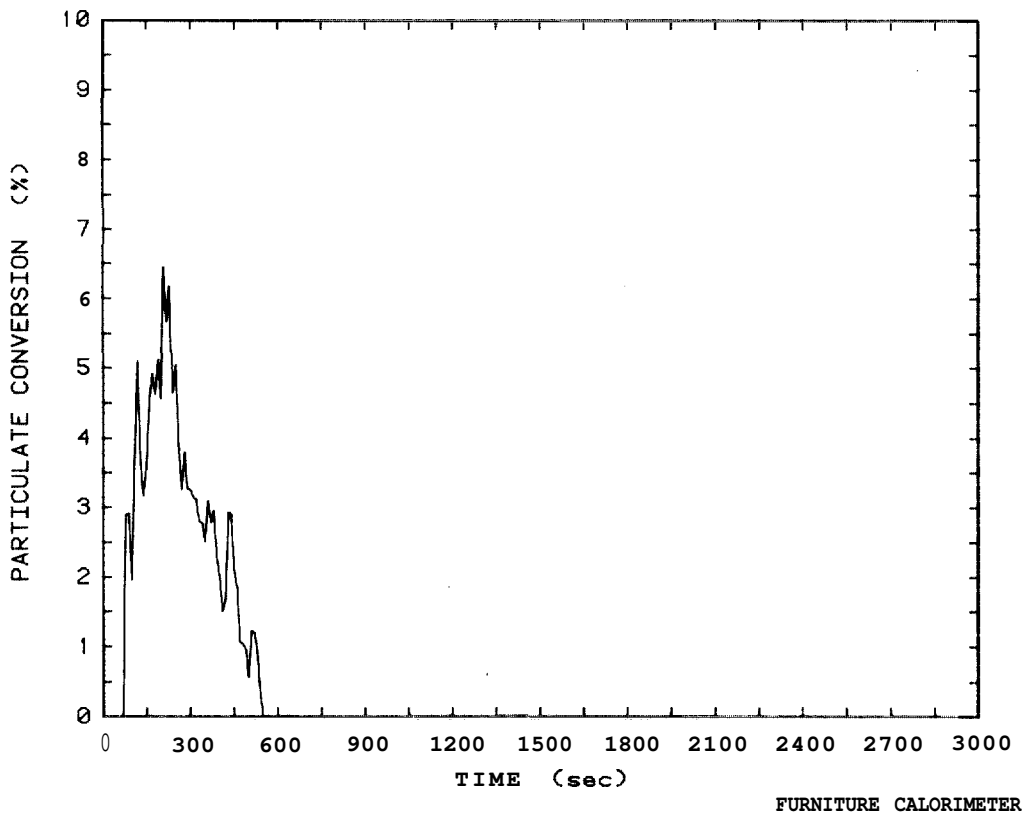

Figure 47: Smoke particulate conversion plot for metal frame chair, Test 53

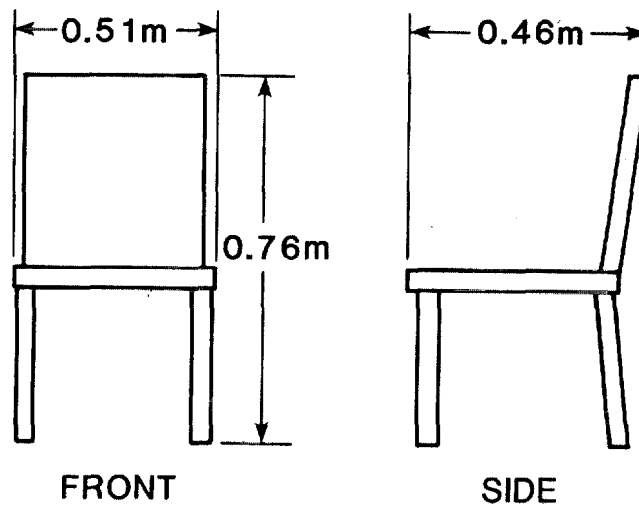
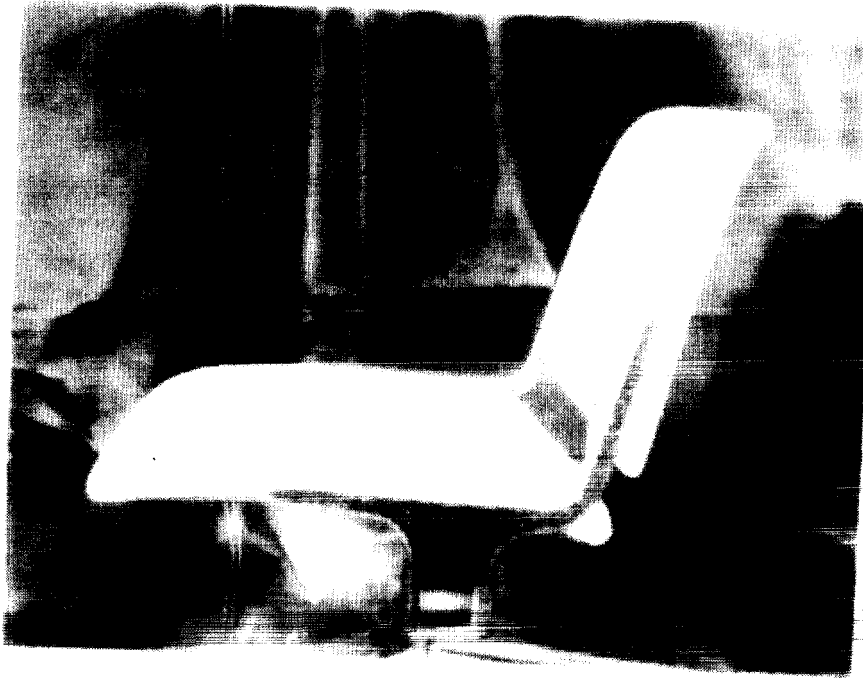

Figure 48. Photograph and dimensions of chair from group setting, test 55

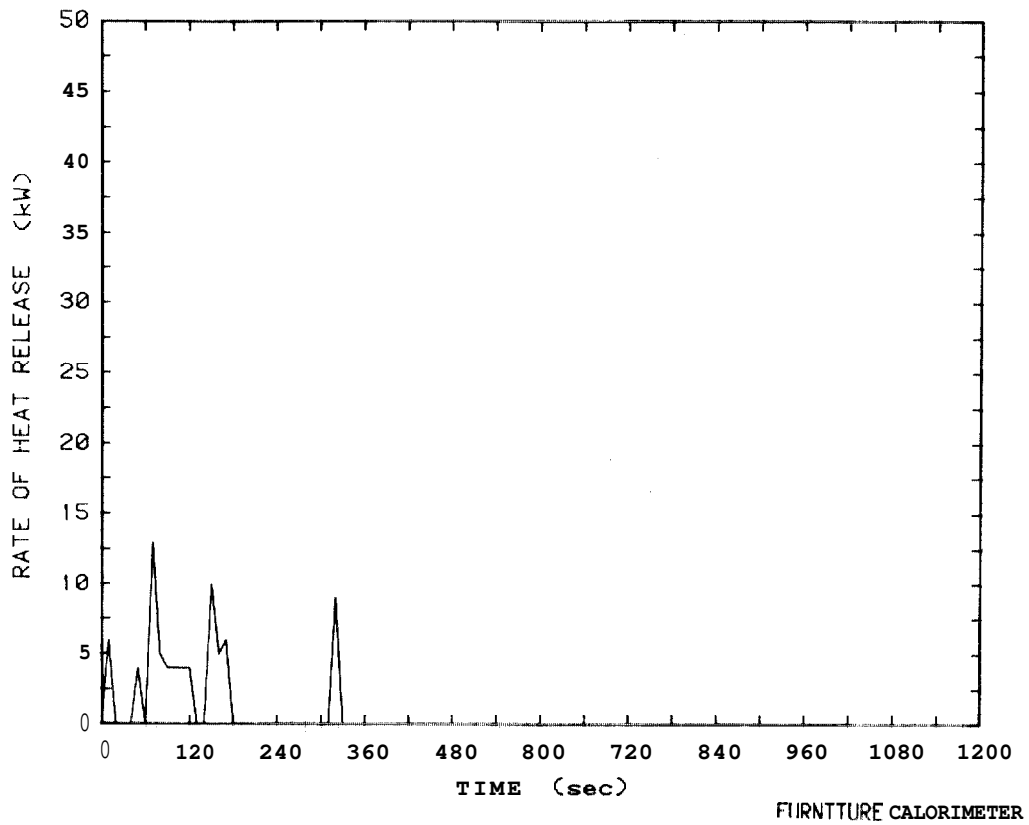

Figure 49: Rate of heat release plot for chair from group setting, Test 55

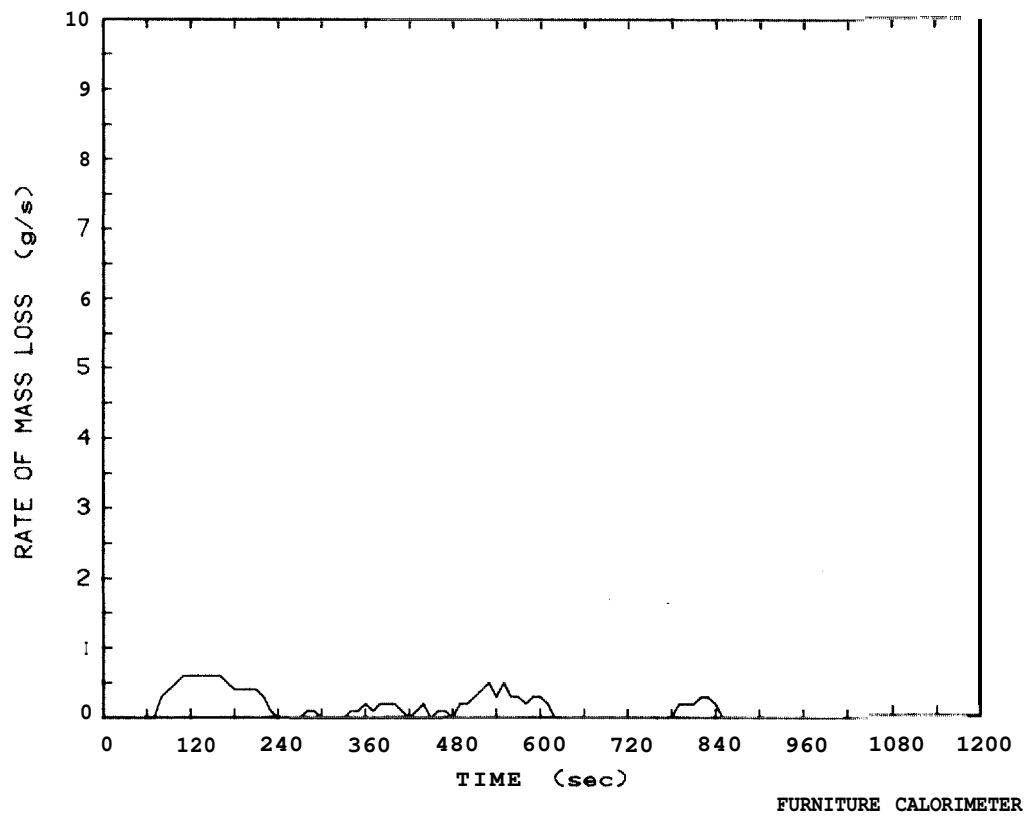

Figure 50: Rate of mass loss plot for chair from group setting, Test 55

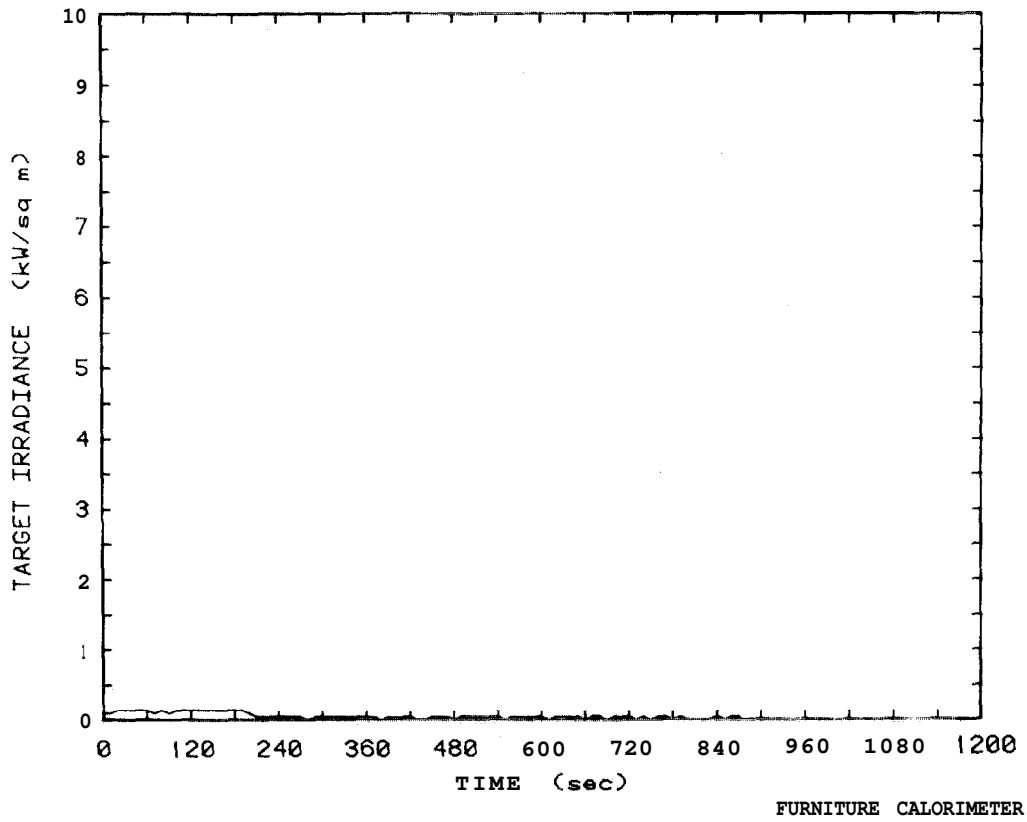

Figure 51: Target irradiance plot for chair from group setting, Test 55

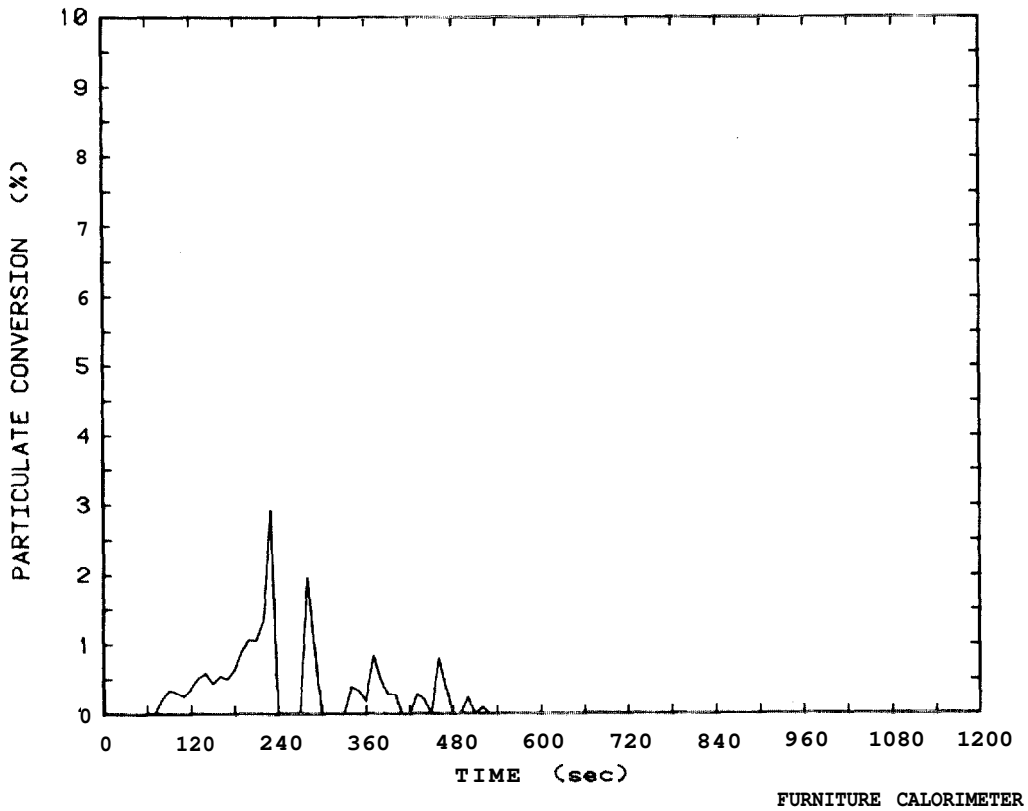

Figure 52: Smoke particulate conversion plot for chair from group setting, Test 55

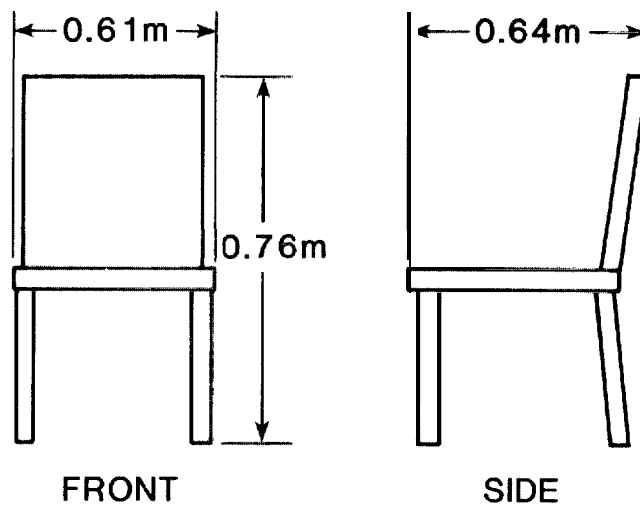
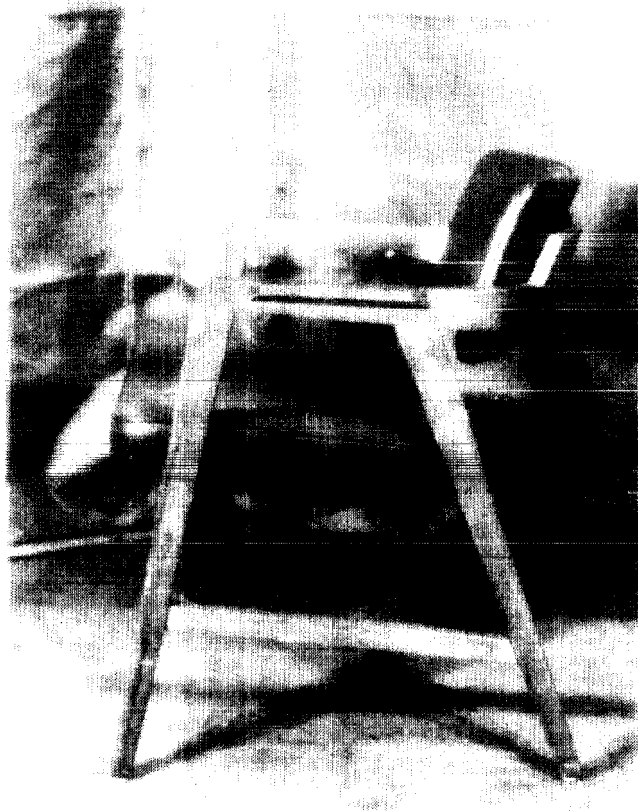

Figure 53. Photograph and dimensions of chair with latex foam cushions, test: 56

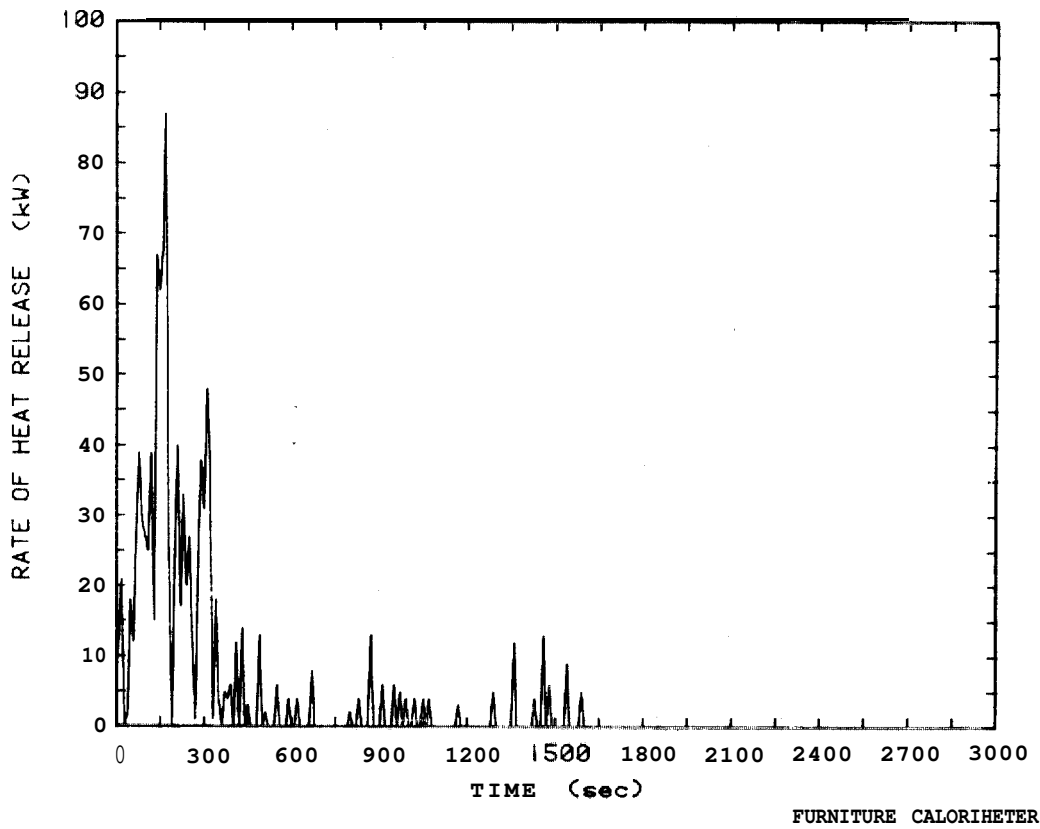

Figure 54: Rate of heat release plot for chair with latex foam cushions, Test 56

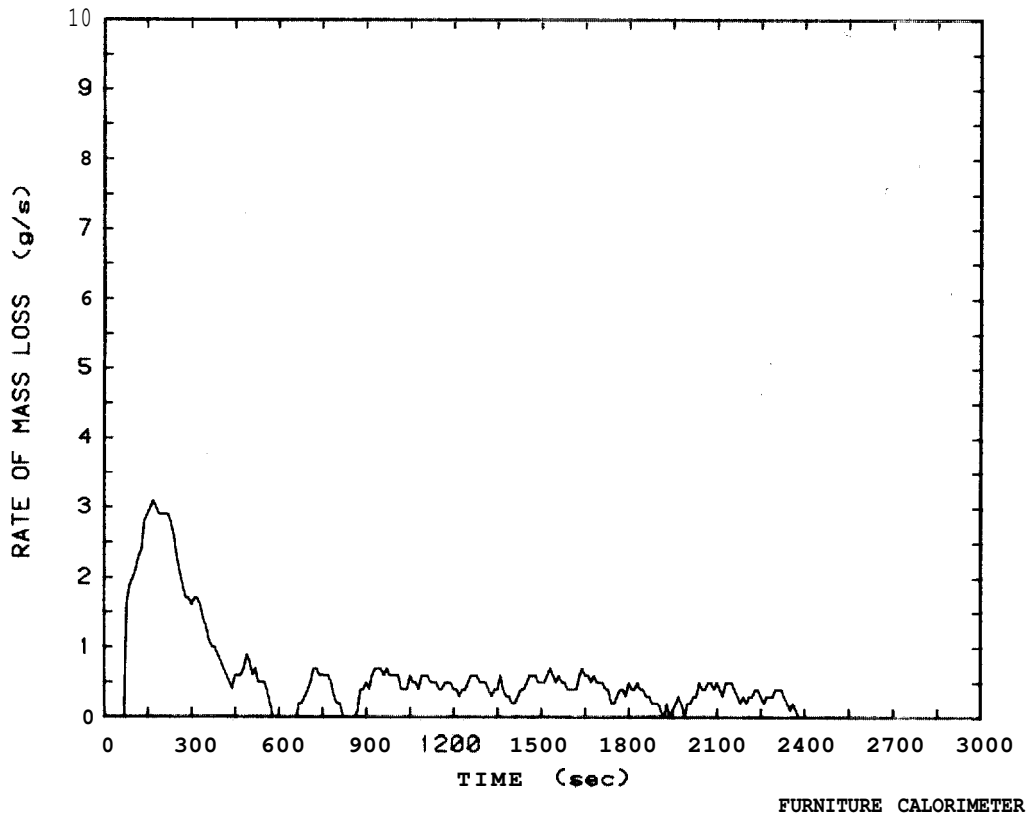

Figure 55: Rate of mass loss plot for chair with latex foam cushions, Test 56

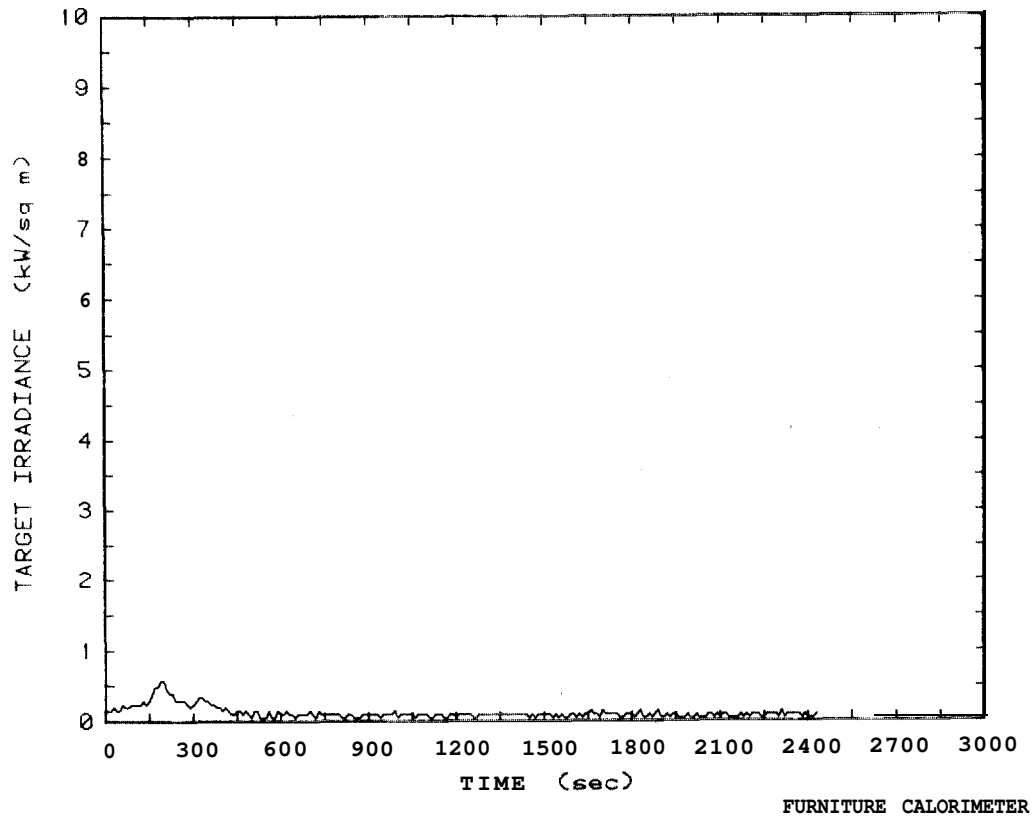

Figure 56: Target irradiance plot for chair with latex foam cushions, Test 56

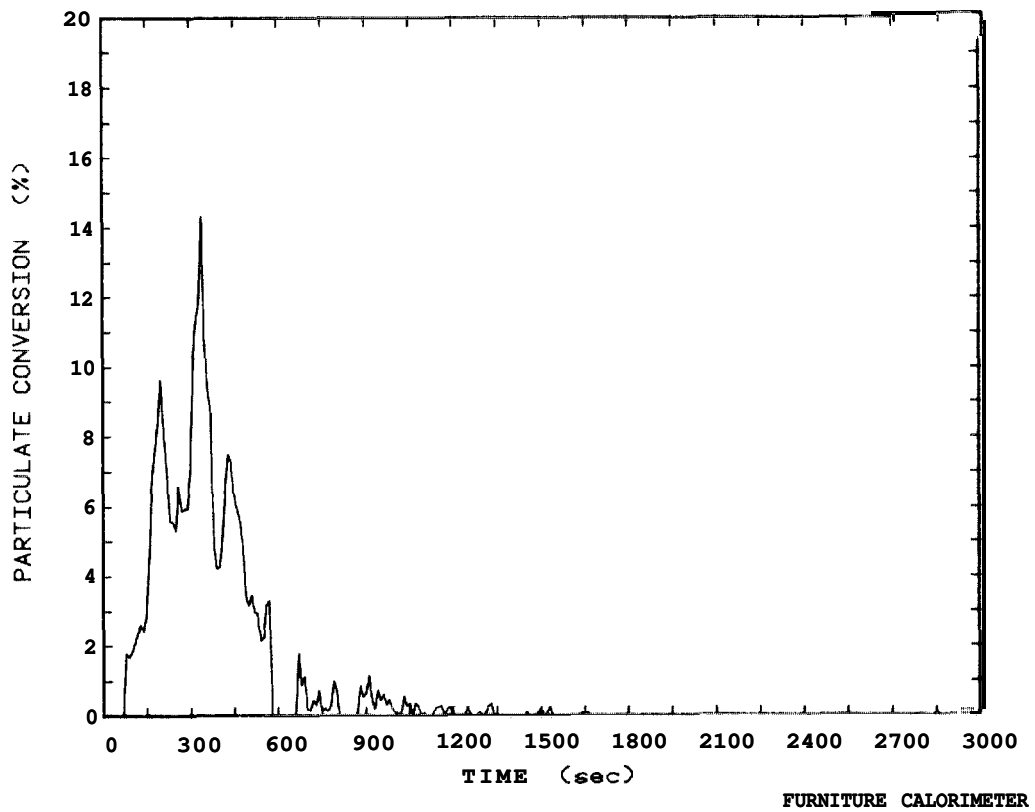

Figure 57: Smoke particulate conversion plot for chair with latex foam cushions, Test 56

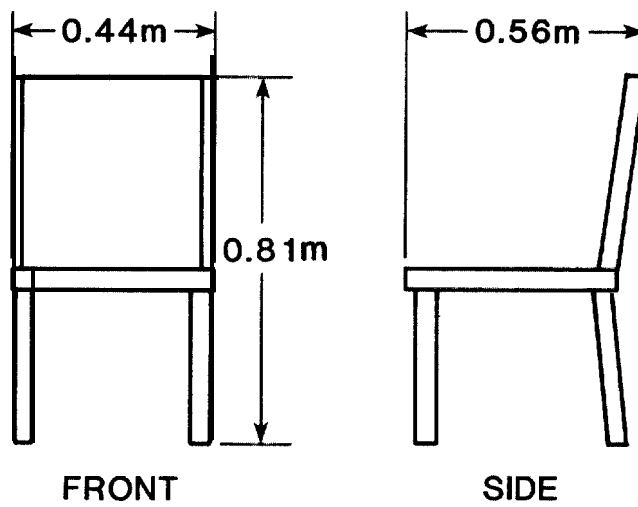
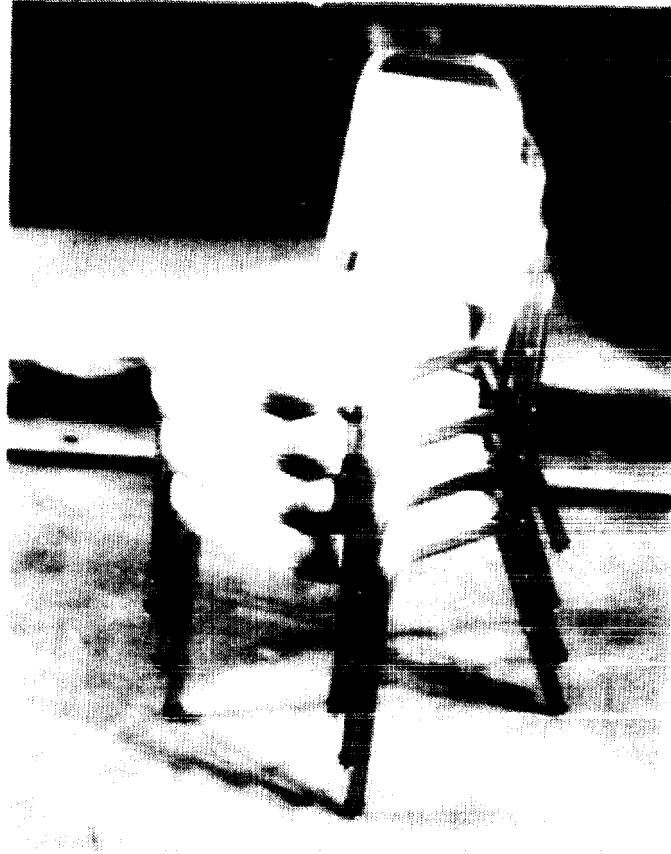

Figure 58. Photograph and dimensions of metal frame stackable chairs, test 75

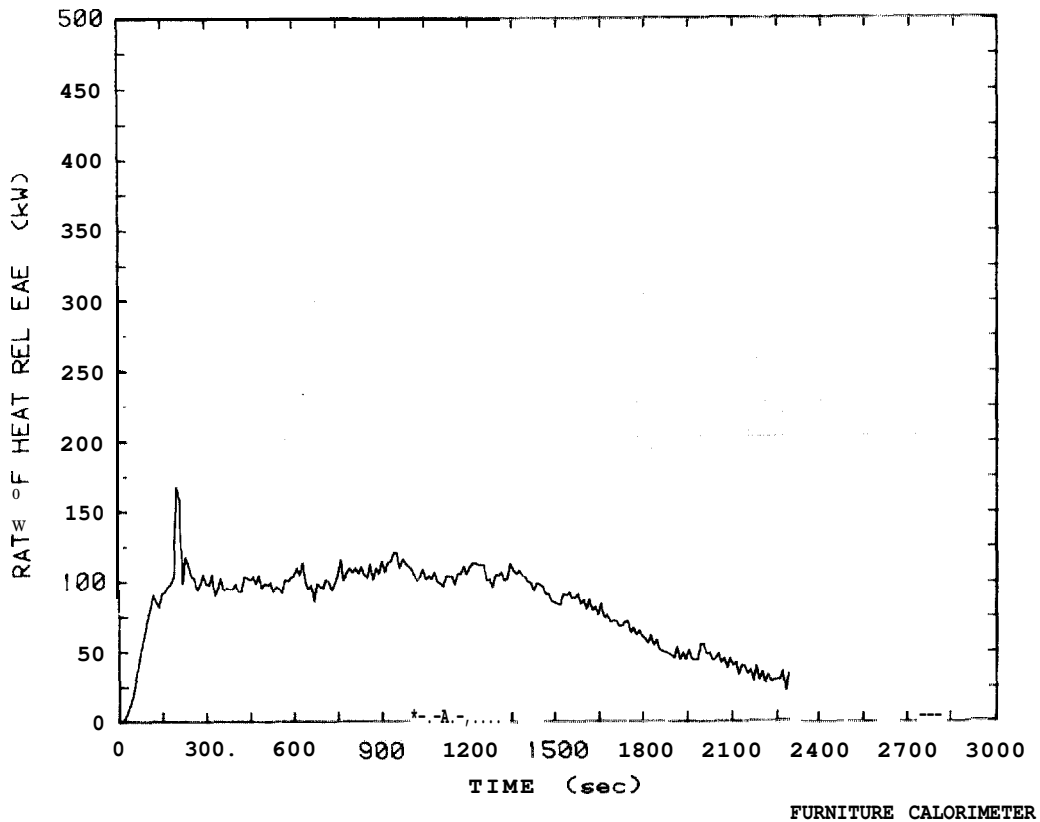

Figure 59: Rate of heat release plot for metal frame stackable chairs, Test 75

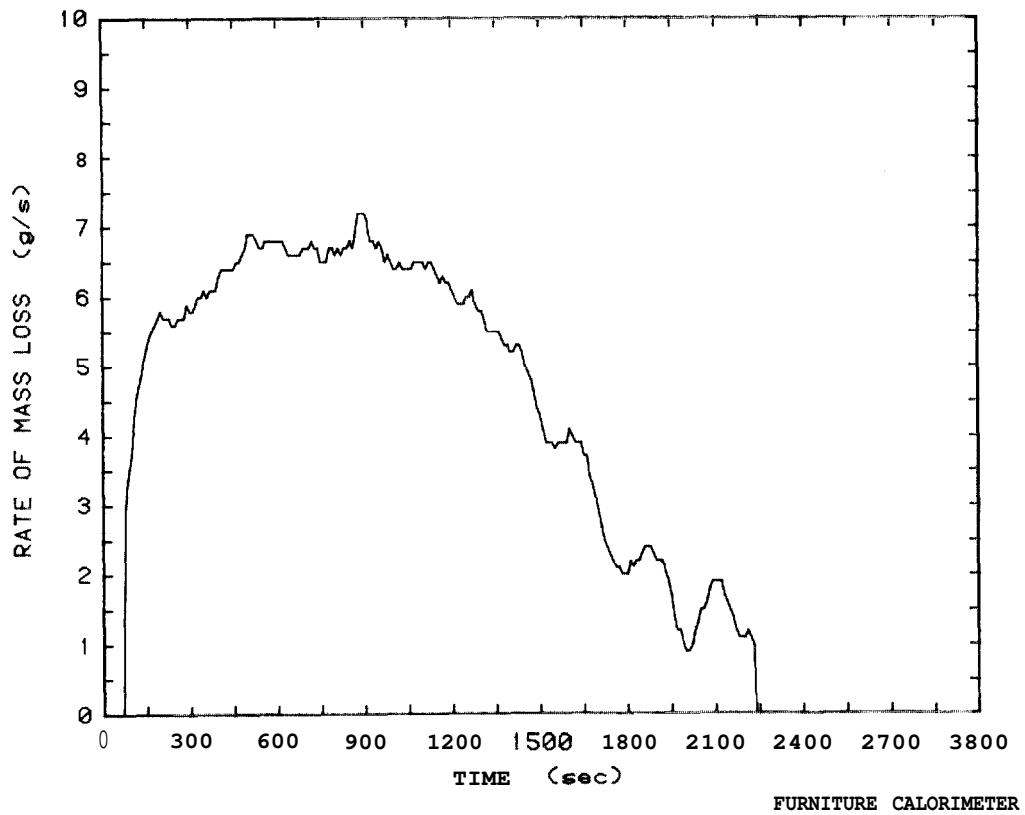
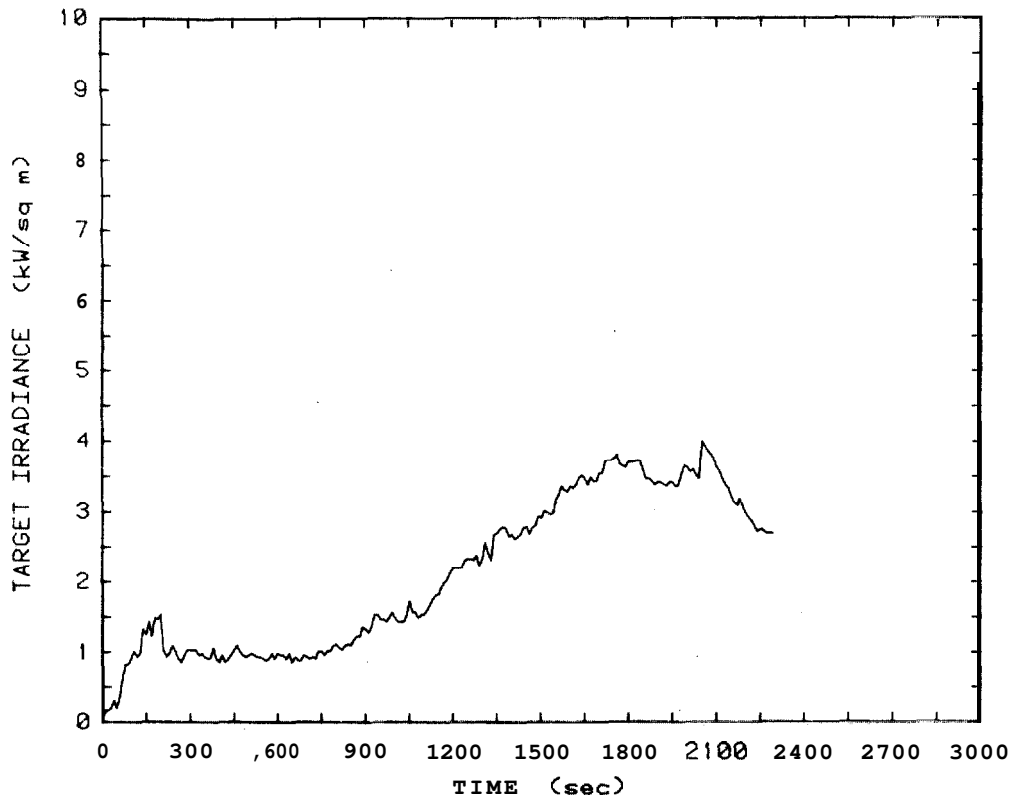
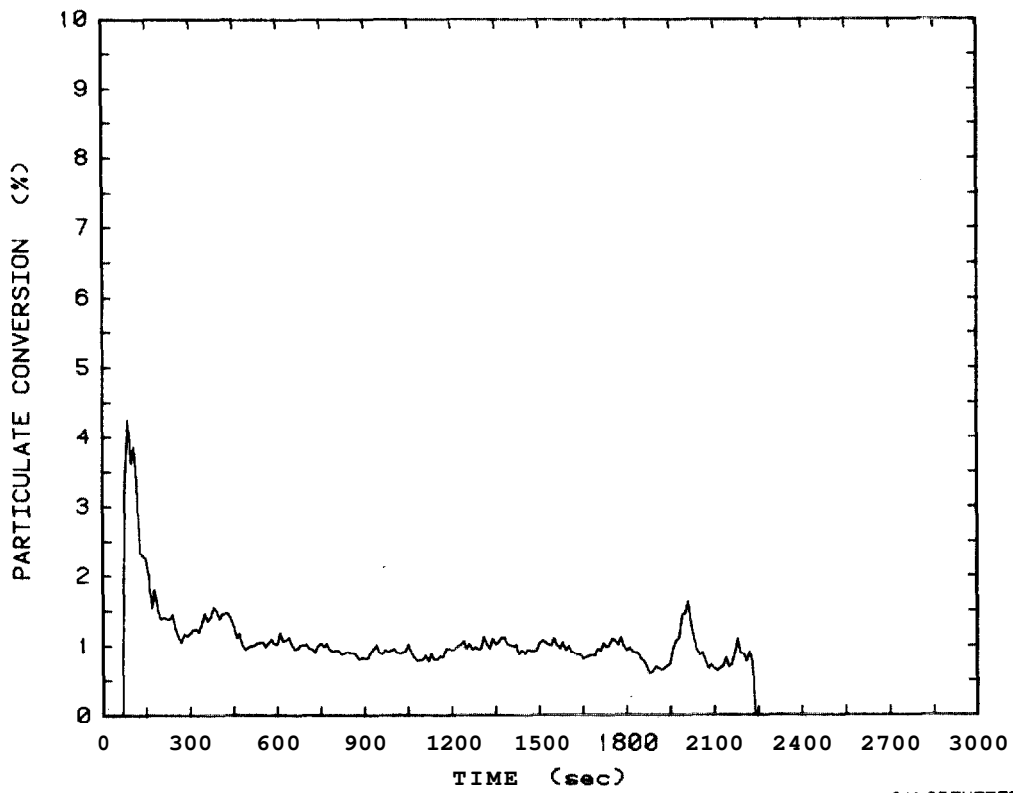

Figure 60: Rate of mass loss plot for metal frame stackable chairs, Test 75



FURNITURE CALORIMETER

Figure 61. Target irradiance plot for metal frame stackable chairs, Test 75



FURNITURE CALORIMETER

Figure 62. Smoke particulate conversion plot for metal frame stackable chairs, Test 75

6. SOFAS AND BEDDING

6.1 Description of Sofas and Bedding

In this group, one sofa and two loveseats were tested. These furniture items are the types that will be found in waiting rooms or private residences. The two bed mattress are representative of those found in public dwellings such as hotels and some retirement homes and private residences. Figures showing photographs of these furnishings are located with the data at the end of section 6.2.

Test 38 - This sofa had a wood frame and its cushions were made of "California foam". The fabric cover was polyolefin. This sofa was built by the same manufacturer as the chair in test 45 and it's mass was 51.50 kg. (See figure 63.)

Test 54 - This **loveseat** consisted of a metal frame with four solid polyurethane foam filled cushions. The cushions were covered with a plastic coated **fabric** and the mass was 27.26 kg. (See figure 68.)

Test 57 - This **loveseat** was constructed with an oak wood frame with exterior end panels made of 9.5 mm plywood covered **with** polyurethane foam padding and a plastic coated fabric cover. The seat and back cushions consisted of solid polyurethane foam covered with a layer of cotton. The cushions were covered with a plastic coated fabric. The loveseat's mass was 54.60 kg. (See figure 73.) The photograph shows several burn marks on the **loveseat** which resulted from dropped **cigarettes**. This piece of furniture was obtained from a hospital.

Test 67 - The mattress was constructed with 312 unit **W/flexedge** wires, 40% blended cotton felt, 40% polyurethane foam, and 20% sisal spring cover. The boxspring had a wood frame with a plastic net coil spring 'unit and a blended cotton felt insulator. The total mass of the mattress and boxspring was 62.36 kg. (See figure 78.)

Test 74 - The full-size spring-core mattress was covered with a quilted ticking over layers of polyurethane foam, fiber batting and a second layer of foam. (See figure 81.) Mass for this specimen was not determined.

6.2 Results and Discussion of Sofa and Bedding Tests

Data for all the furnishings tested in this group are found in table 6. The sofa and two love seats were ignited using the procedure stated in section 3.2.2 and the two bedding tests were ignited using the procedures in section 3.2.3.

The sofa burned in test 38 produced the largest peak rate of heat release in this furniture group with a peak rate greater than 3000 **kW**, and it also had the greatest total heat release. See figures 64-67. This rate of heat release would cause flashover or rapid fire development in any average size waiting room [12]. The peak mass loss rate was high, and the peak target irradiance was about 38 **kW/M²**. This amount of thermal radiation would easily ignite almost any common combustible item found in a typical living quarter [13]. Also, this sofa produced the greatest amount of carbon monoxide experienced in this group of furniture.

In test 54, the metal frame **loveseat** had the lowest peak heat release rate of this group. Data **plots** for test 54 are found in figures **69-72**. The wood frame **loveseat** evaluated in test 57 was not easily ignited **with the gas** ignition flame because a plywood panel was located under the fabric on the ends. See figures 74-77. The peak heat release rate did not occur until **the seat** and back cushions became involved. The peak particulate conversion for smoke was 10.7 percent. This was experienced early in **the test as a** result of burning inside the loveseat's arm which was exposed to the ignition source. Large quantities of smoke were experienced until **the** seat and back cushions became fully involved and then smoke production dropped rapidly as **particulates** and the **loveseat** were consumed. The second greatest peak carbon monoxide level for this category of furnishings was experienced with this loveseat.

The first bedding materials were burned in test 67. The photograph in figure 78 shows the mattress after being exposed to lit cigarettes in an earlier test. None of the cigarettes resulted in the ignition of the mattress. The results from this test are shown in figures 79 and 80. Mass loss was not measured in **this** test because the mattress and boxspring were larger in size than the load cell platform. Therefore, results on smoke particulate conversion and total smoke produced are not available, as well as, values on rate of mass loss and heat of combustion. The initial peak heat release rate resulted from the burning mattress. The secondary peak heat release rate resulted from the burning boxspring. The second bedding burn was test 74. As seen in figure 81, cigarettes were also used unsuccessfully as an ignition source with this mattress. **However,** ignition of the sheet with a cigarette lighter resulted in a fully involved mattress in 740 seconds. See

figure 82. In this test, the target irradiance was not measured and again, as in test 67, the load platform was not used.

Table 6. Test Results on Sofas and Bedding

	Test No.	Specimen Mass (kg)	Heat Release Rate (kW)		Total Heat Release (MJ)	Peak Mass Loss Rate (g/s)	Average Heat of Combustion (MJ/kg)	Peak Target Irradiance (kW/M ²)	Smoke Peak Particulate Conversion (%)	Total Smoke Produced (g)	Peak Carbon Monoxide (g/s)
			Initial Peak	Secondary Peak							
Sofa California Foam Cushions	38	51.50	3200	N	714	145.3	18.9	38.0	3.2	558	4.5
Loveseat, Metal Frame Foam Cushions	54	27.26	370	N	108	19.9	18.6	1.7	6.8	382	2.3
Loveseat, Wood Frame Foam Cushions	57	54.60	1100	N	608	61.9	15.1	6.4	10.7	910	4.0
Mattress and Boxspring, Cigarette Lighter Ignition	67	62.36	530	660	342	(1)	(1)	7.4	(1)	(1)	1.6
Mattress, No Boxspring, Cigarette Lighter Ignition	74	--	1700	N	204	(1)	(1)	(1)	(1)	(1)	0.8

N - No second peak.

(1) - Data not taken during the test.

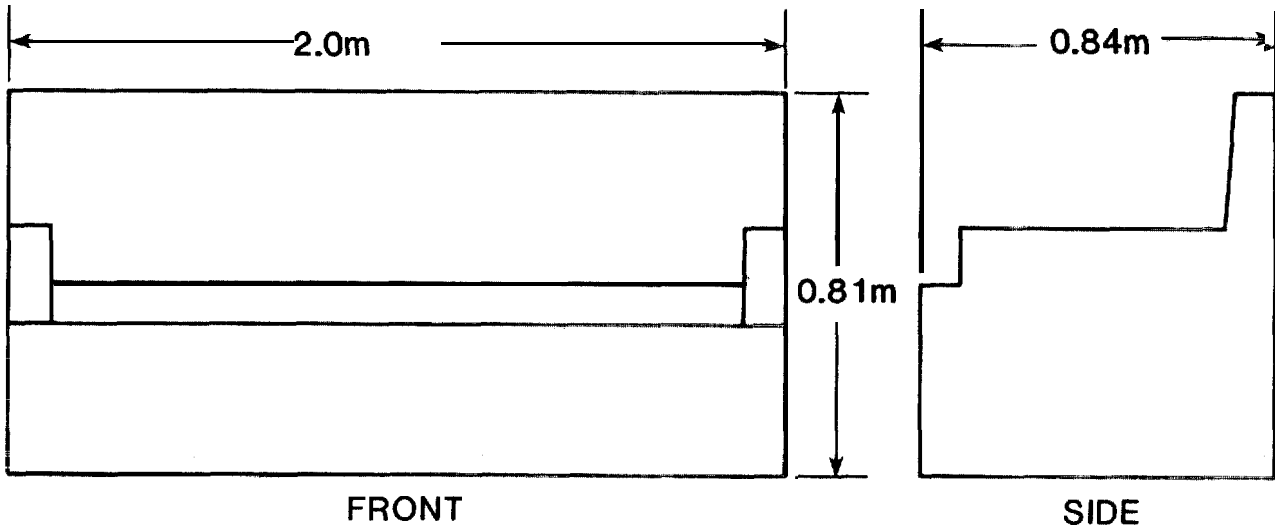

Figure 63. Photograph and dimensions of sofa with "California foam" cushions, test 38

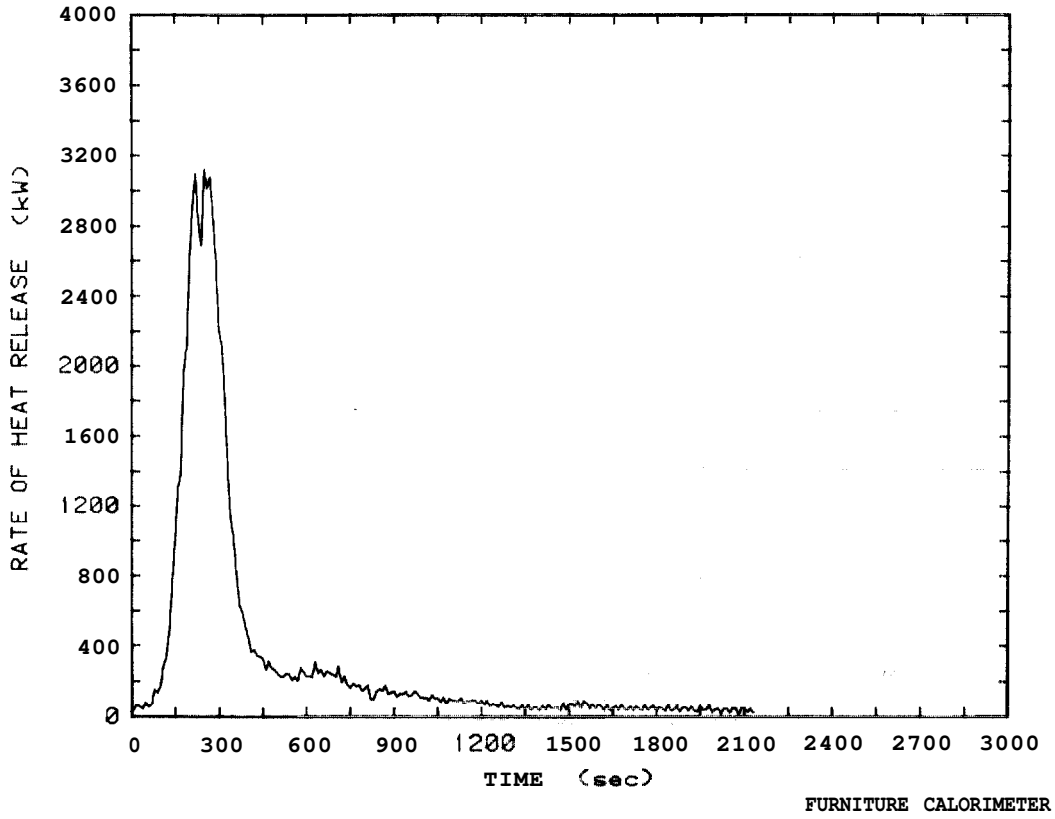

Figure 64. Rate of heat release plot for sofa with "California foam" cushions, Test 38

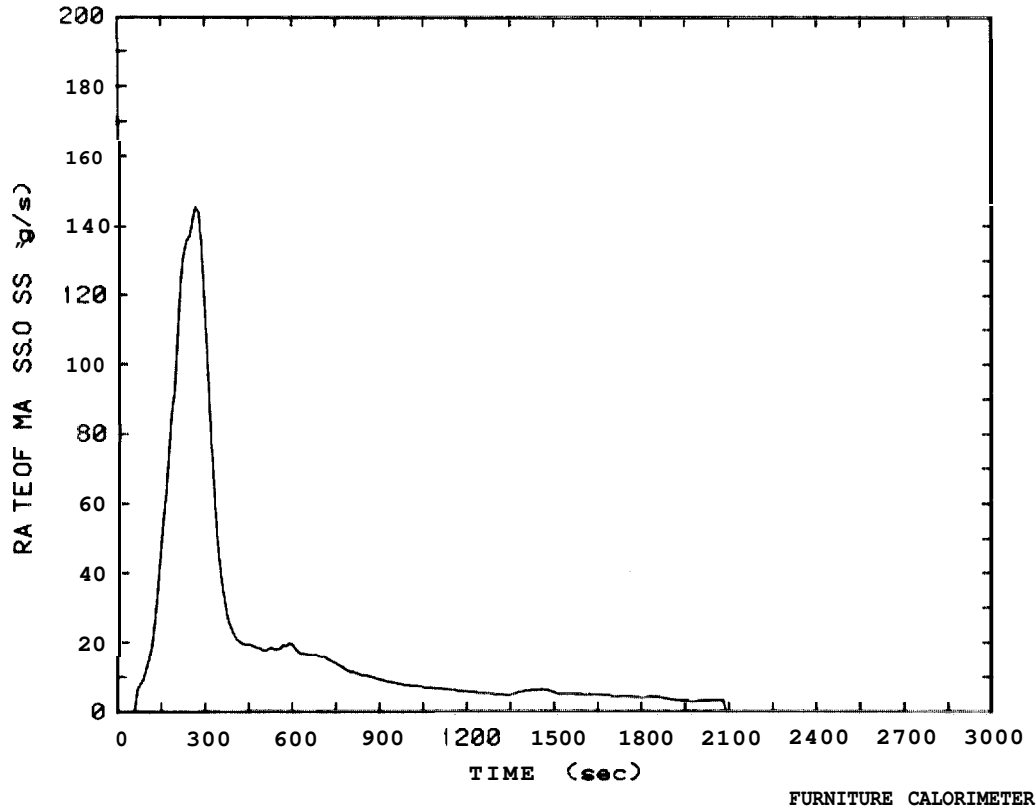
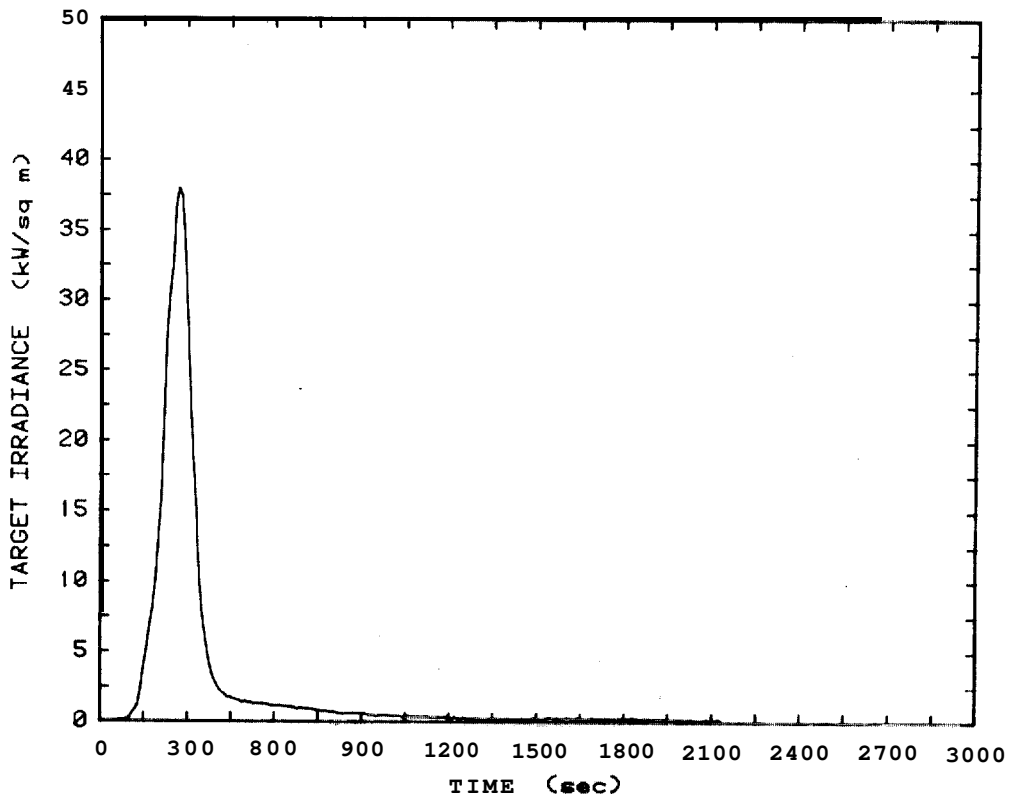
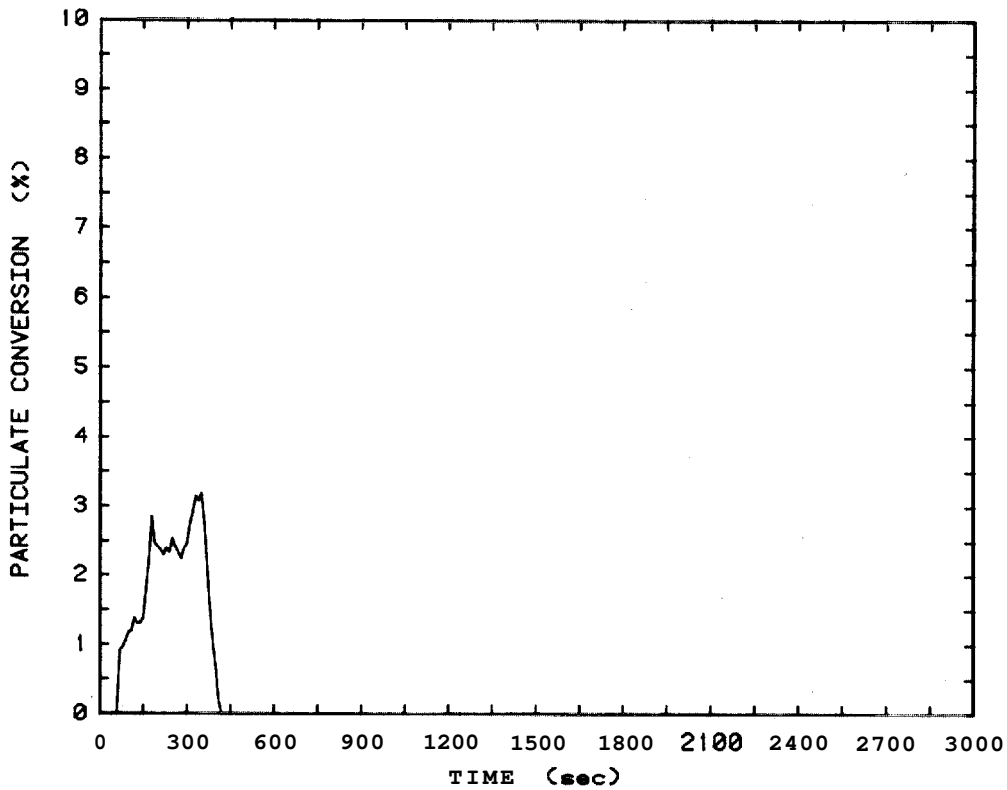

Figure 65. Rate of mass loss plot for sofa with "California foam" cushions, Test 38



FURNITURE CALORIMETER

Figure 66. Target irradiance plot for sofa with "California foam" cushion, Test 38



FURNITURE CALORIMETER

Figure 67. Smoke particulate conversion plot for sofa with "California foam" cushions, Test 38

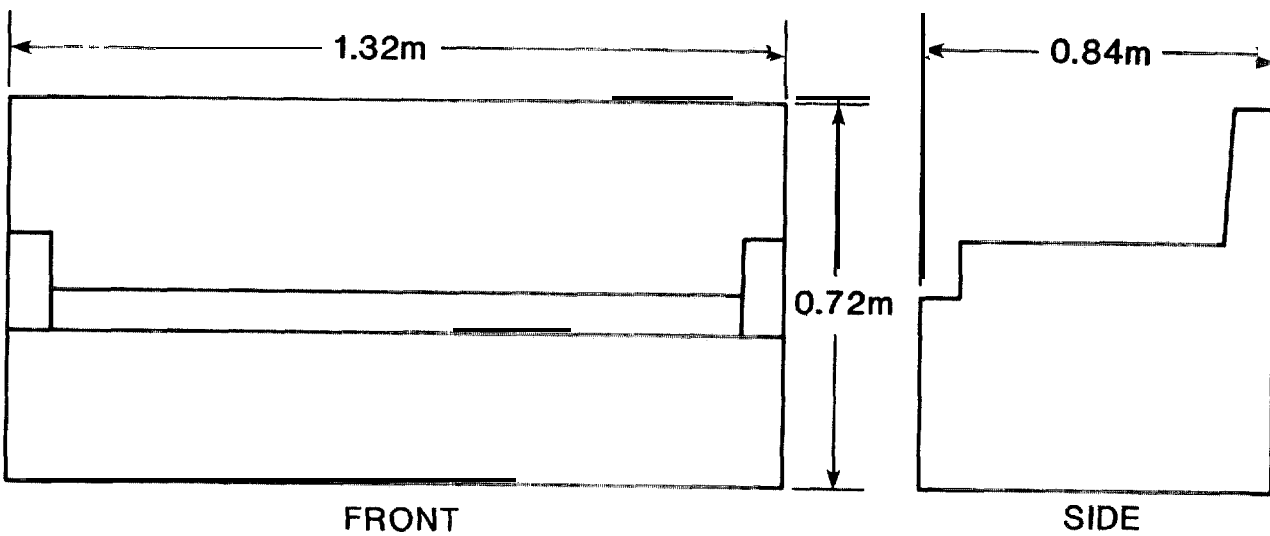
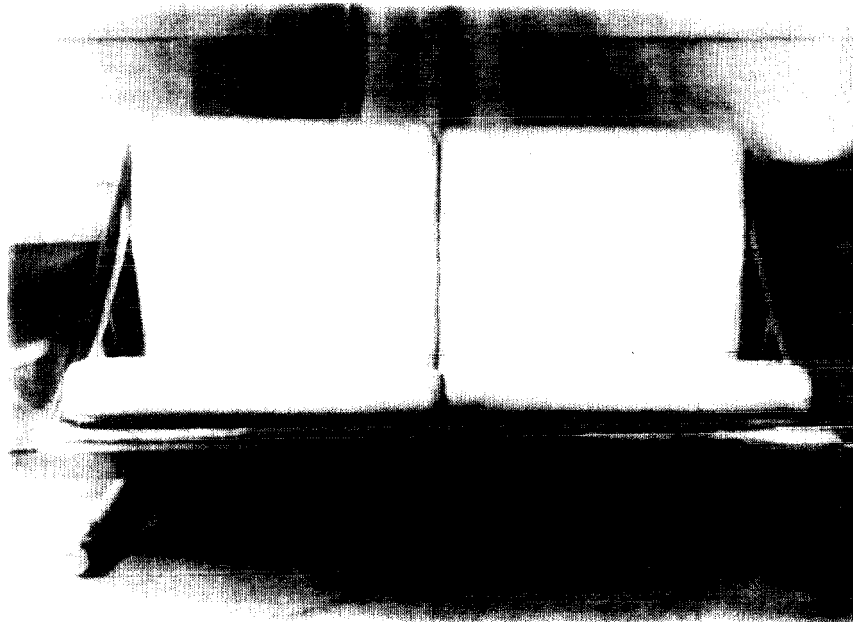

Figure 68. Photograph and dimensions of metal frame loveseat, test 54

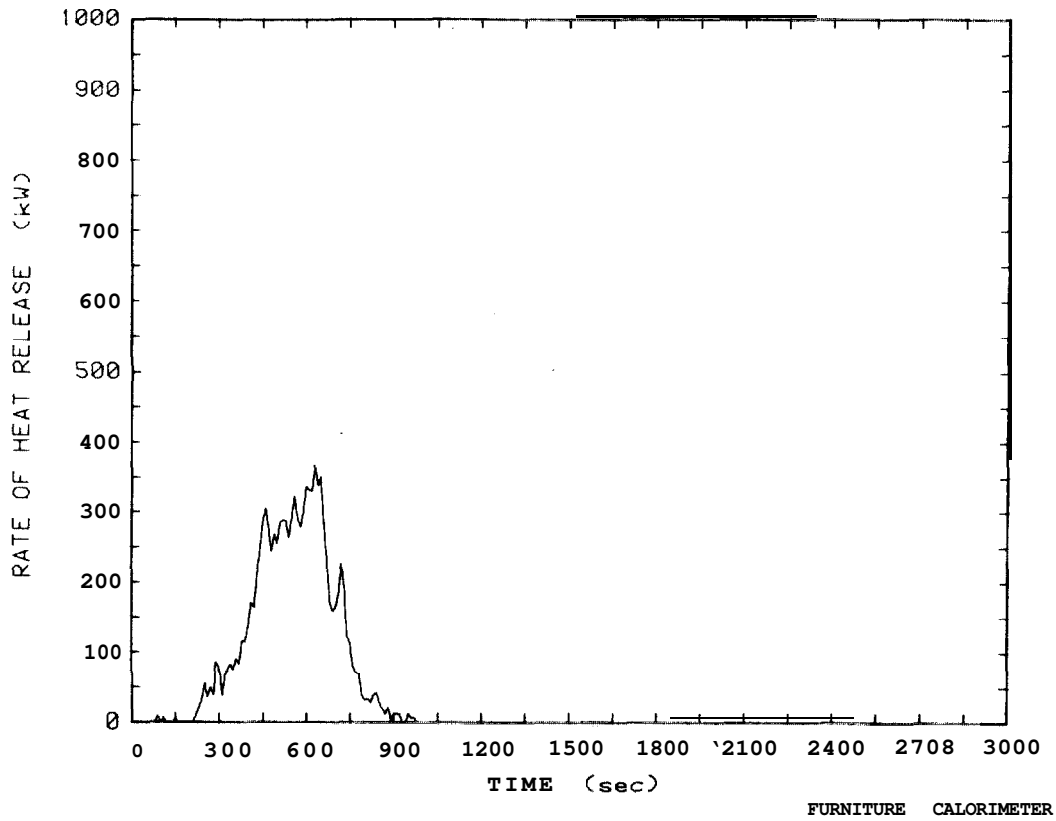

Figure 69. Rate of heat release plot for metal frame loveseat, Test 54

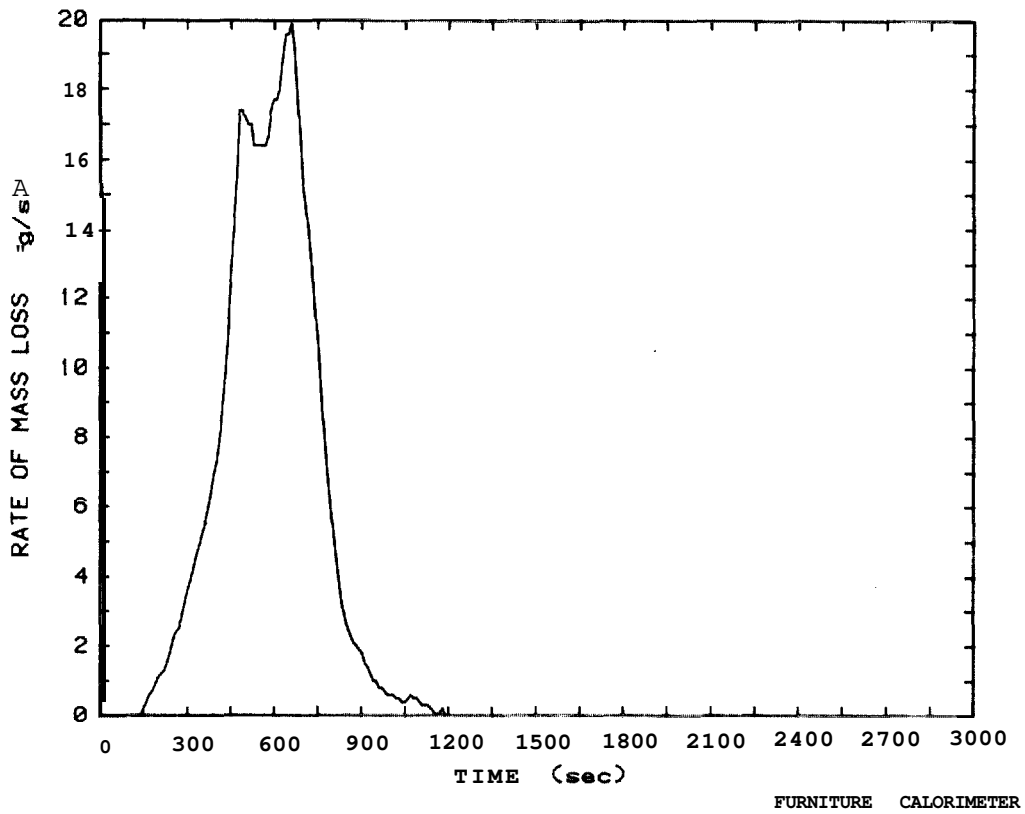

Figure 70. Rate of mass loss plot for metal loveseat, Test 54

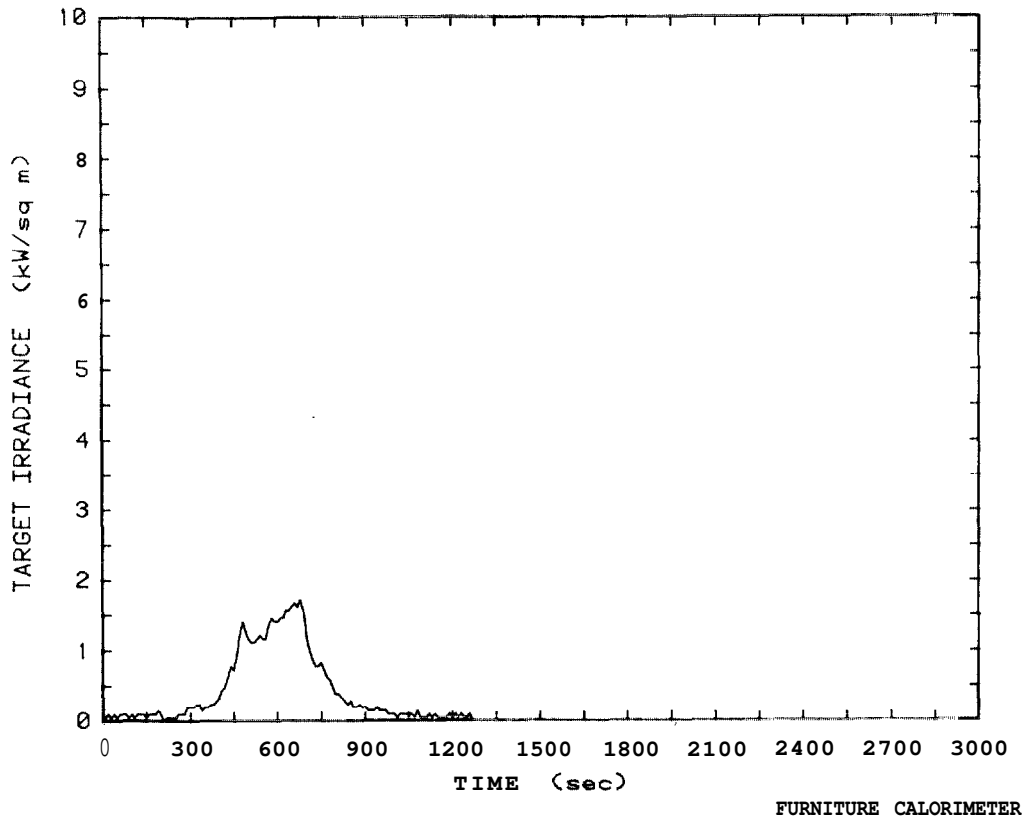

Figure 71. Target irradiance plot for metal. frame loveseat, Test 54

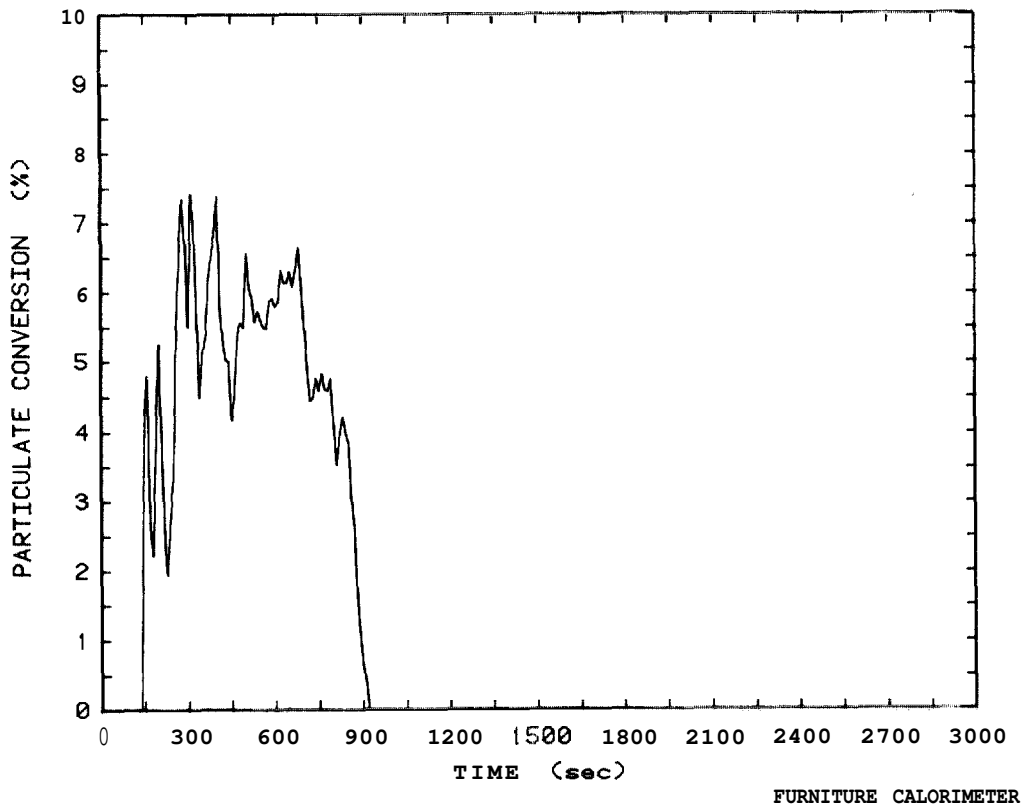

Figure 72. Smoke particulate conversion plot for metal. frame loveseat, Test 54

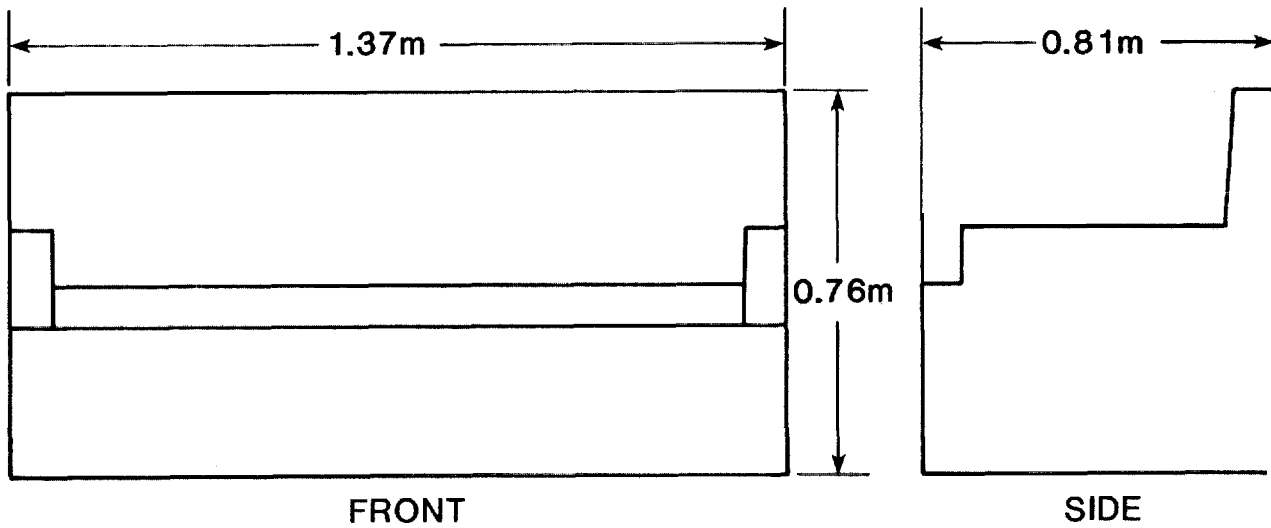
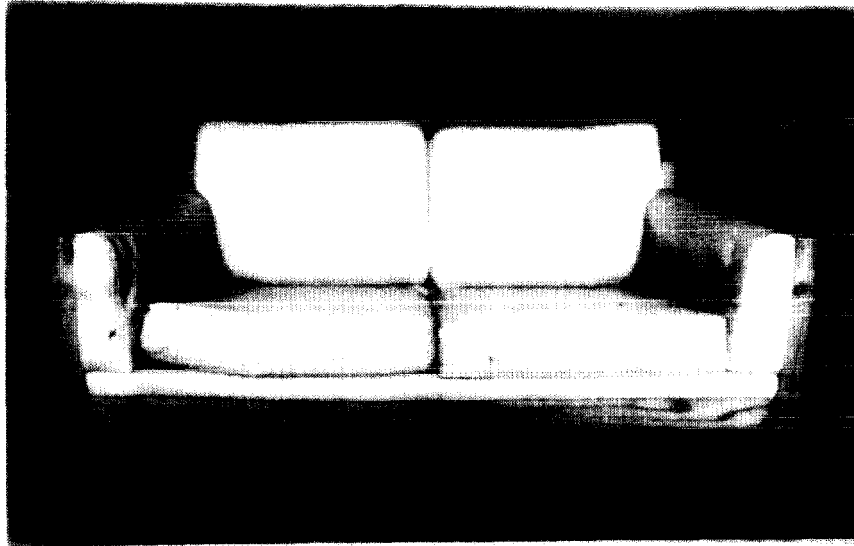

Figure 73. Photograph and dimensions of wood frame loveseat, test 57

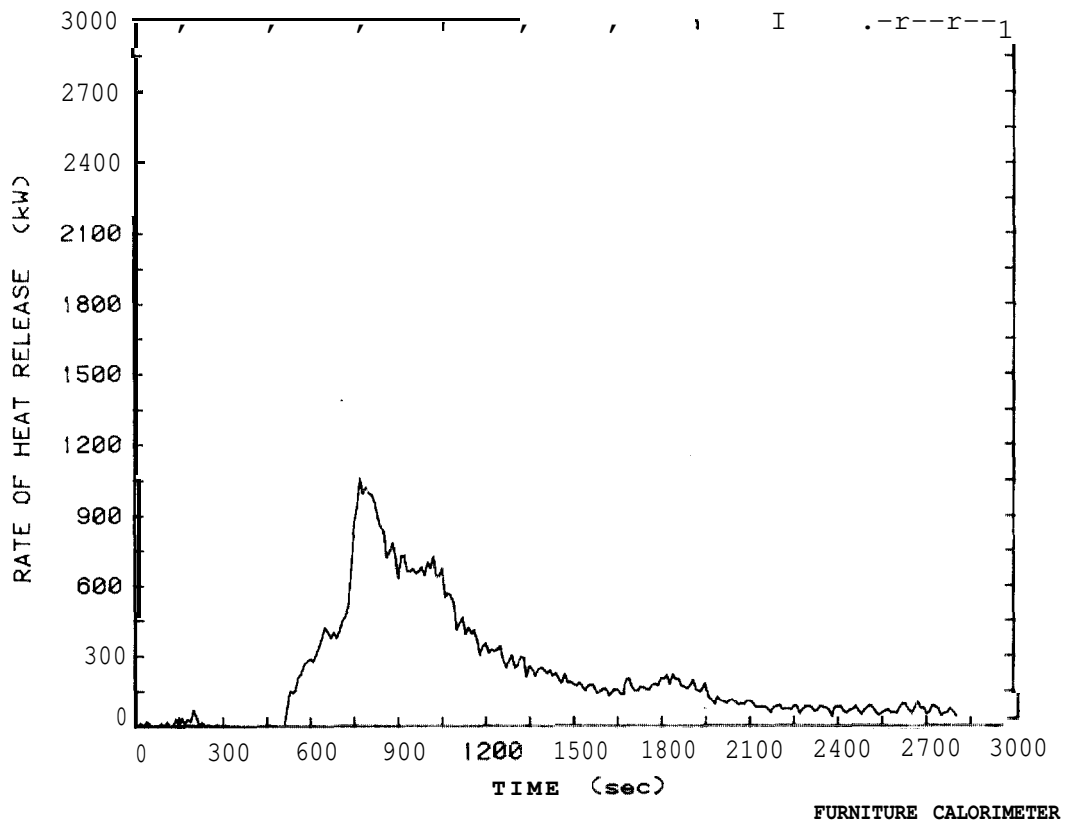

Figure 74. Rate of heat release plot for wood frame loveseat, Test 57

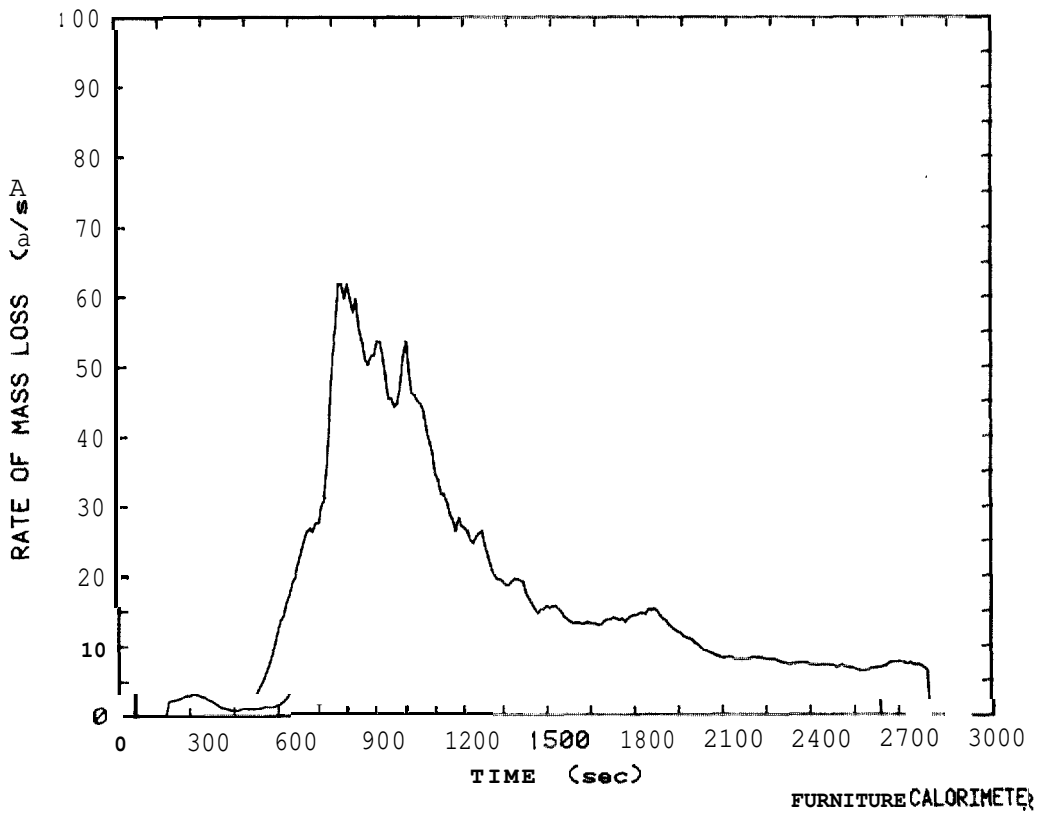

Figure 75. Rate of mass loss plot for wood frame loveseat, Test 57

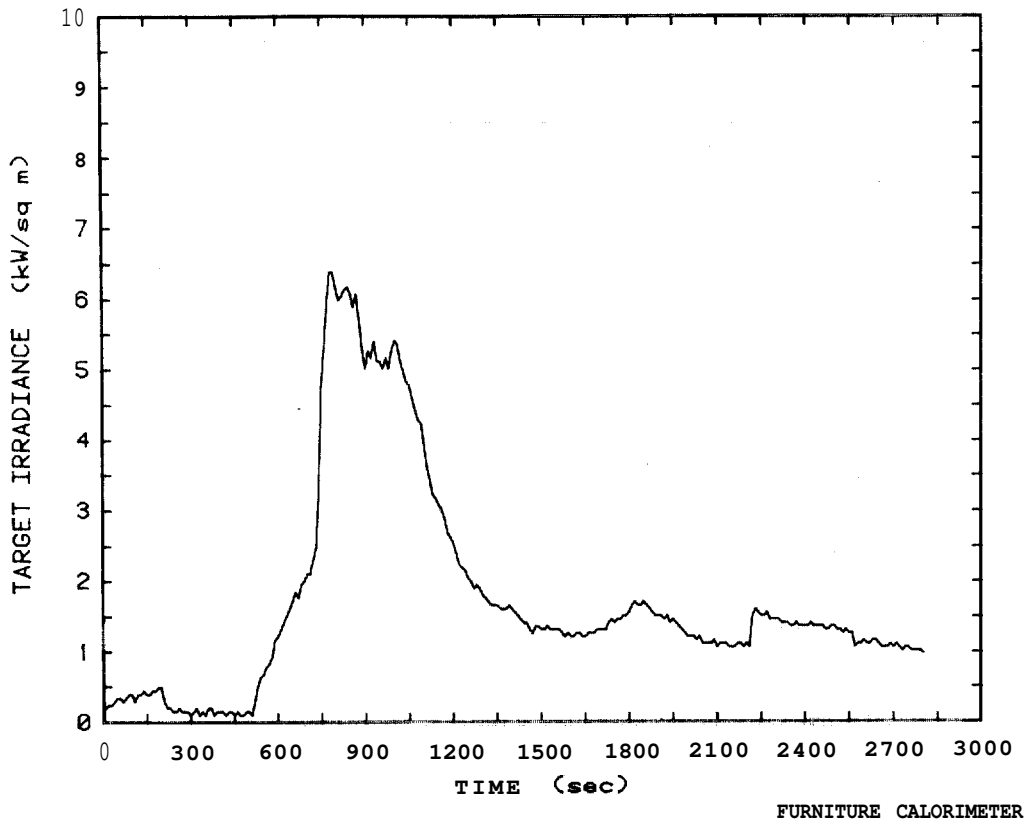

Figure 76. Target irradiance plot for wood frame loveseat, Test 57

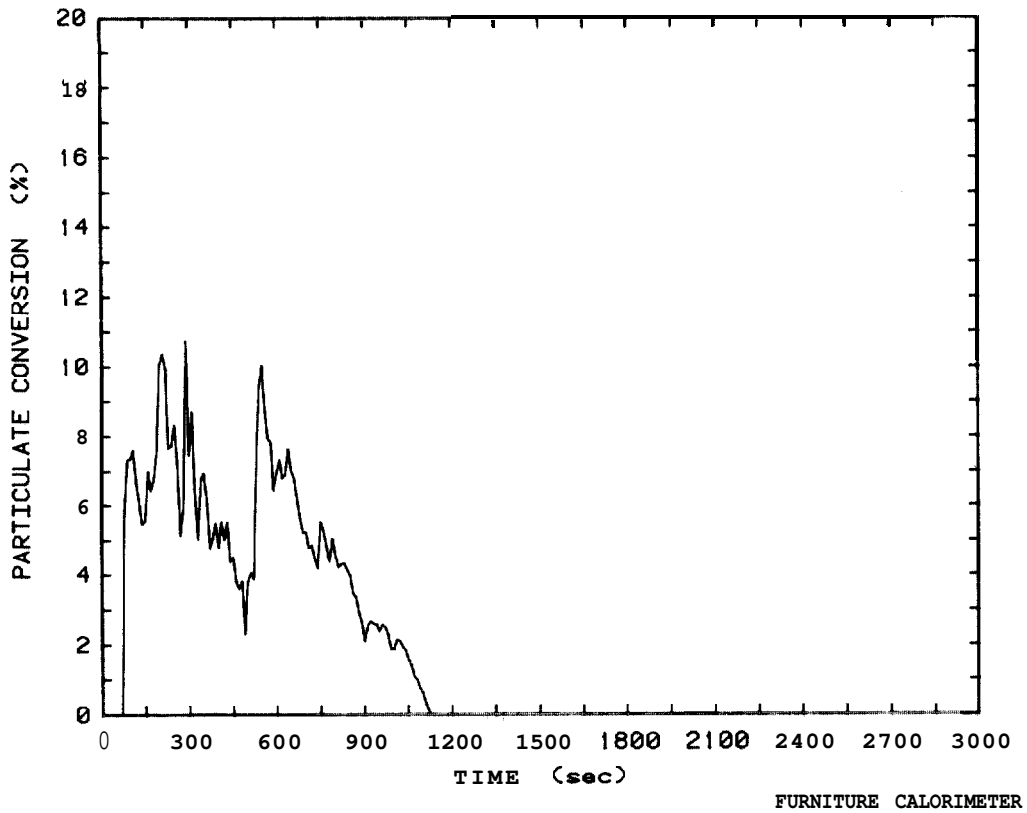

Figure 77. Smoke particulate conversion plot for wood frame loveseat, Test 57

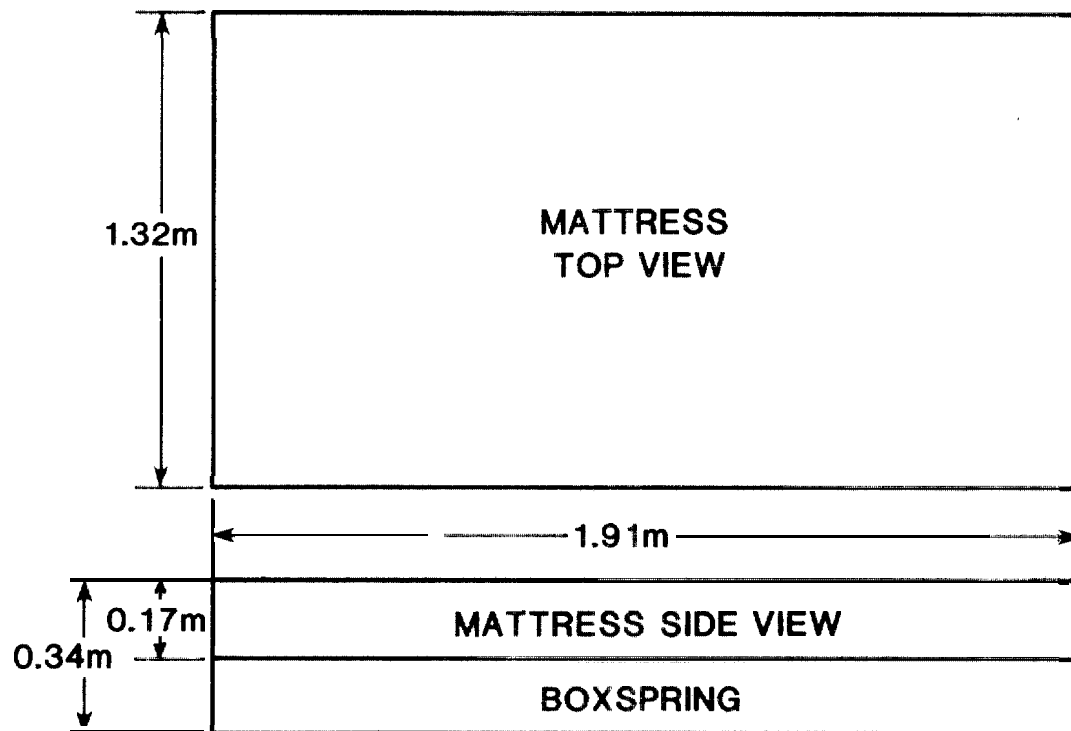

Figure 78. Photograph and dimensions of mattress and boxspring, test 67

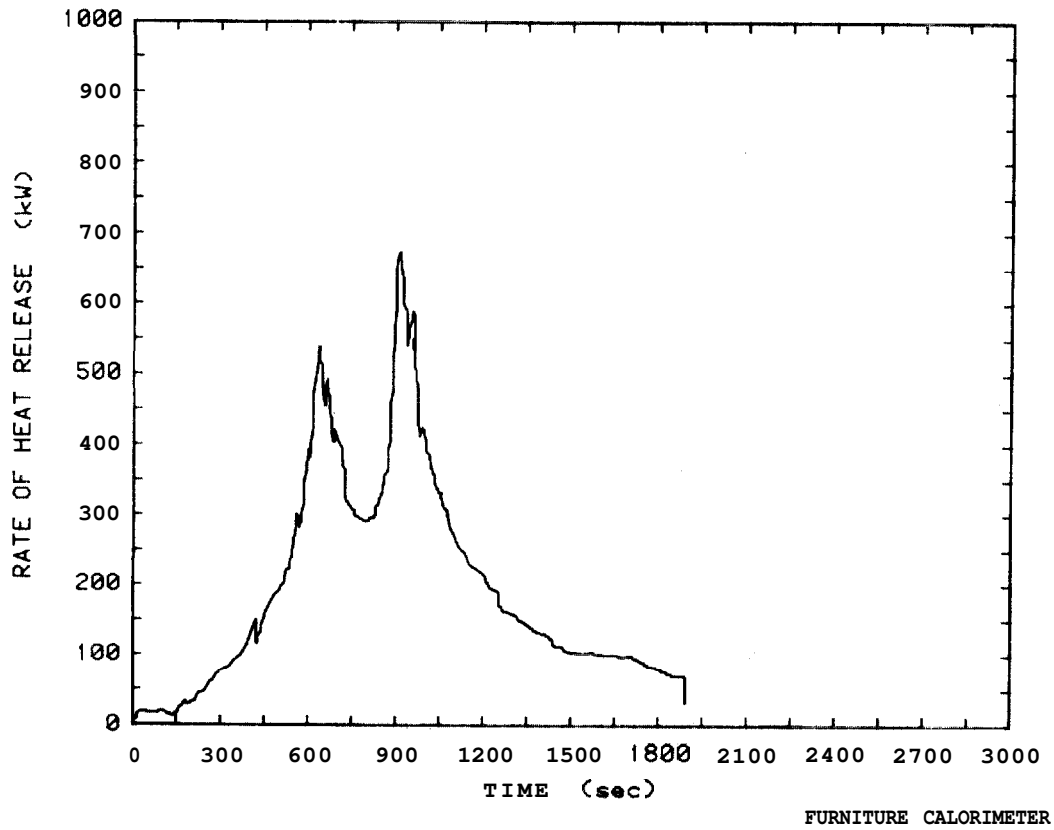

Figure 79. Rate of heat release plot for mattress and boxspring, Test 67

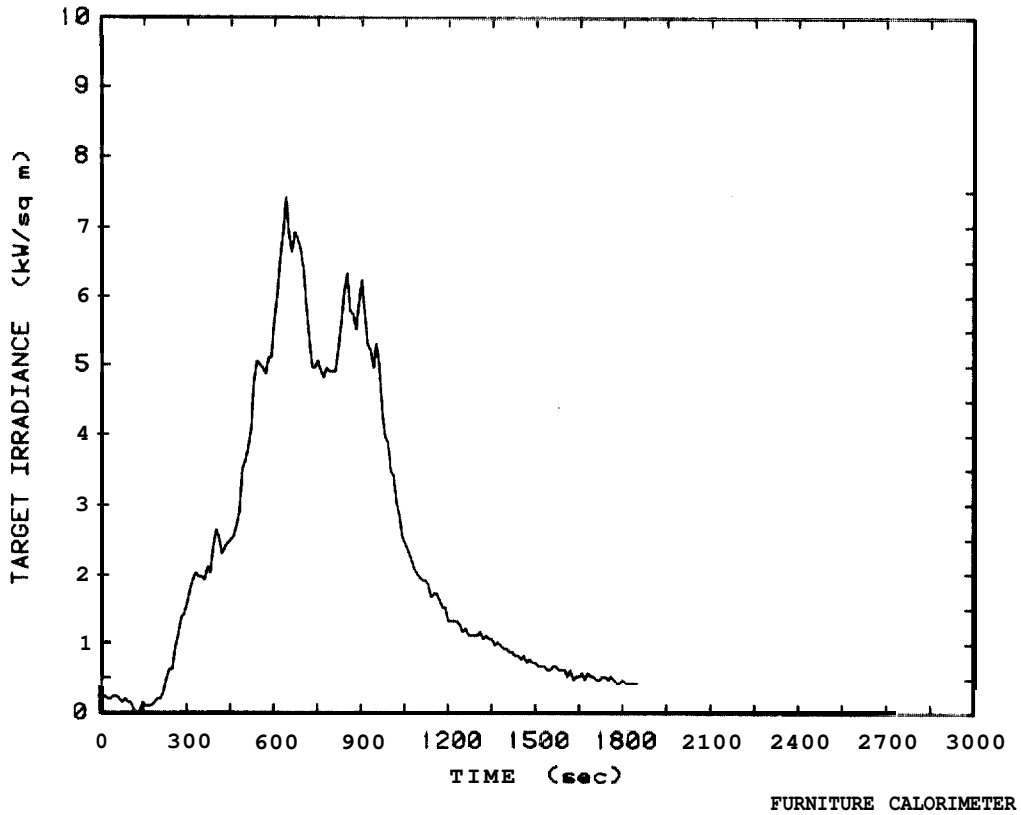

Figure 80. Target irradiance plot for mattress and boxspring, Test 67

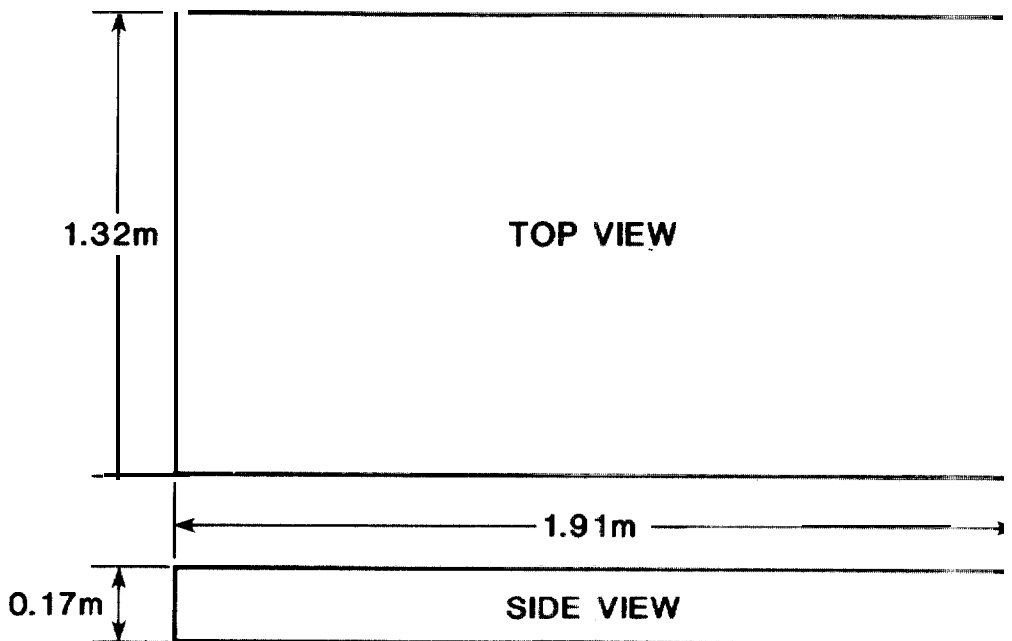

Figure 81. Photograph and dimensions of mattress, test 74

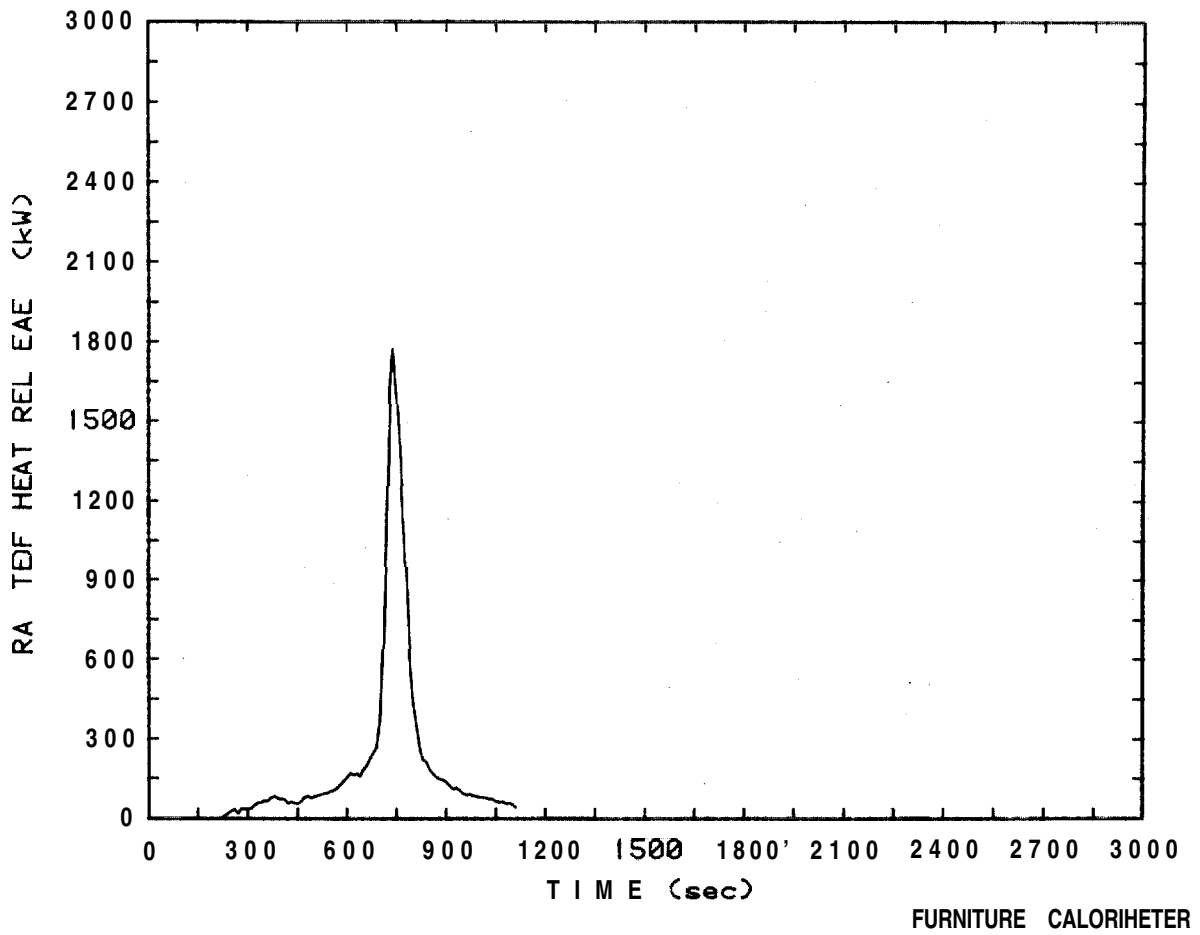

Figure 82. Rate of heat release plot for mattress Test 74

7. WARDROBE CLOSETS AND BOOKCASE

7.1 Description of Wardrobe Closets and Bookcase

The four wardrobe closets in this furniture group are of the types generally used in nursing homes and **hospitals** for storage of clothes and personal items of patients. These furnishings are also sold for use in private residences. The bookcase is of a design typically found in waiting rooms. Figures showing photographs of the wardrobes and bookcase are located with the data at the end of section 7.2.4.

Tests 15 and 21 - The wardrobe closet used in these tests was constructed from 0.69 mm thick sheet steel, A sheet metal shelf extended completely across the interior, 216 mm down from the top. Two metal doors were hinged to swing open on the front. This was a commercially manufactured item and was originally coated with a brown colored paint. This wardrobe's mass was approximately 41 kg. (See figure 83.)

Tests 39, 40 and 43 - These wardrobes were constructed at the National Bureau of Standards from 12.7mm thick Douglas-fir plywood. The wardrobe had two 12.7 mm plywood doors hinged on the front for access to the interior. No finish was applied to either the inside or outside and no surfaces were sanded smooth. 'These wardrobes had a mass approximately 68 kg each. (See figure 90.)

Tests 41, 42 and 44 - These wardrobes were commercially manufactured units. They were built with 3.2 mm thick Philippine mahogany veneer plywood and hardboard on a 19 by 40 mm hardwood frame. The top, bottom, and back were hardboard with the sides and doors constructed from plywood. Two rolling doors provided access to the interior. A 384 mm deep shelf extended across the width of the wardrobe just above the hanger rod. In test 41, the wardrobe had no finish. In test 42, the wardrobe was painted inside with one coat of oil-based fire-retardant paint. In test 43, the wardrobe was painted inside and out with two coats of latex fire-retardant paint. These paints exhibited intumescence when exposed to heat. These wardrobes had a mass approximately 37 kg each. (See figure 103.)

Test 61 - This wardrobe, with a mass of about 120 kg, was constructed from 19.1 mm thick particle board covered with a thin plastic coating. The wardrobe had one hinged door, a swing down desk, two drawers, and four shelves. The back of the wardrobe was covered with a thin sheet of hardboard. (See figure 120.)

Test 62 - This bookcase was constructed with an aluminum frame and 12.7 mm thick plywood. Two hinged doors were located on the front lower third and two book shelves were located above. The bookcase's mass was 30.39 kg. (See figure 125.)

7.2 Results and Discussion of Wardrobe Closet and Bookcase Tests

7.2.1 Metal Wardrobe

As summarized in table 7, two different metal wardrobe closet tests were conducted. As mentioned in section 2.2, test 15 was run with rags for the fabric fire load. The results are shown in figures 84 and 85. The peak heat release rate of better than 770 **kW** was experienced at 60 seconds into the test. The paper-filled box and the fabrics accounted for this heat release. Target irradiance and smoke particulate was not measured in this test since these instruments were not operating **during** this early test.

Test 21, with the same metal wardrobe as in test 15, was the first test to duplicate the fabric load as used in the sprinkler test program reported by **O'Neill, Hayes, and Zile [7]**, and as shown in table 2. Test results are presented in figures 86-89. This test provided baseline data on the combustible contents placed in the wardrobes as a fire load. The peak heat release rate of the cardboard box with **10** sheets of newspaper and the fabrics was 267 **kW** at 120 seconds into the test. The total heat released by the contents was 52 **MJ** and the maximum target irradiance measured by the radiometer 50 cm above the load platform and centered on the wardrobe's front was 4.0 **kW/M²**. The peak smoke particulate conversion was 3.7 percent with total smoke produced at 14.9 grams. Carbon monoxide production was low.

7.2.2 Plywood Wardrobes (12.7 mm)

All of the 12.7 mm thick plywood wardrobes were tested under the large hood described in section 3.1. The test results are shown in table 7. Test number 39 was the first of the 12.7 mm wardrobe closets burned. See data plots in figures 91-94. The wardrobe doors were attached to chains which were to keep **them** from falling off the load cell platform during the test. However, the fasteners attaching the chains to the plywood structure burned through the plywood and the doors fell. The large mass loss rate spikes shown in figure 92 resulted when the wardrobe doors burned away and fell from the load platform. The zero rate shown at 240 seconds occurred as a gypsum board thermal shield from a nearby experiment fell onto the load platform as a result of the intense fire. The peak mass loss rate was measured just before the doors fell. A second 12.7 mm plywood test number 40 was conducted to obtain the full complement of data from this wardrobe design. See data plots in figures 95-98. A wire cage was constructed on the load platform to keep the wardrobe components from falling off. The wire cage is shown in figure 103. With this test, a mechanical problem was experienced with the load platform which resulted in the mass loss rate spikes in figure 96. The third and final 12.7 mm plywood wardrobe test number 43 was conducted after the load cell problem was corrected. See data plots in figures 99-102. Data spikes also show up on the mass loss rate plots for test 43, but these spikes were observed when the doors dropped to the load platform and coincided with the collapse of the wardrobes structure.

Taking into account the problems associated with the first two tests, analysis of the data shows good repeatability with an average peak rate of heat release of 3300 kW, a standard deviation of 208 kW, and a coefficient of variation of 6.3 percent. The total heat release for tests 40 and 43 are substantially close, but are somewhat higher than those for test 39. The total heat release shown for test 39 is lower as a result of the doors falling away and not continuing to burn.

7.2.3 Plywood Wardrobes (3.2 mm)

Three tests were conducted using the 3.2 mm thick plywood wardrobes. As mentioned in section 7.1, one was unpainted and two were painted with different applications of fire-retardant paint. All of these tests were conducted under the large calorimeter hood. Test results for these three tests are shown in table 7.

The first of these wardrobes tested was unpainted and the data plots for test 41 are shown in figures 104-107. This wardrobe, with the fabrics and newspaper, had a mass of 36.00 kg. When the box of newspaper was ignited, the wardrobe ignited and burned rapidly. The peak heat release rate was in excess of 6000 kW at 130 seconds into the test with a peak rate of mass loss of 301 g/s. This was the fastest burning item with the greatest peak heat release rate of this research project. This magnitude of heat release rate was totally unexpected.

The second 3.2 mm plywood wardrobe was evaluated in test 42. This wardrobe was painted inside with an oil-based intumescent fire-retardant paint. The results are shown in figures 108-112. The peak heat release rate for this wardrobe was approximately 1000 kW less than that of the unpainted wardrobe in test 41. The peak heat release rate occurred at 170 seconds into the test as compared to the time to peak of 130 seconds for the unpainted specimen. Thus, inside painting of the wardrobe appears to have reduced the time to peak heat release rate by 40 seconds. The peak rate of mass loss for this test was also less than test 41 but only by 50 g/s. A peak target irradiance for test 42 was measured at 190 seconds into the test. As seen in table 7, the highest rate of carbon monoxide production was experienced with a value of 12.6 grams per second. Since the production of CO in this test was particularly significant, the curve for CO production is given in figure 111. This test produced the most CO of all of the furnishings tested in this project.

As a result of the high heat release rate experienced with the partially painted 3.2 mm plywood wardrobe, the interior and exterior of a third wardrobe were painted with two coats of latex intumescent fire-retardant paint. The specimen was burned and the results are shown as test 44 in table 7 and figures 113-116. The peak heat release rate for this wardrobe was a reduction of more than 50 percent when compared with the peak value of the unpainted wardrobe in test 41. A comparison of these heat release rate results is shown in figure 117. In addition, the peak heat release rate for test 44 occurred at 170 seconds equaling the time-to-peak for wardrobe test 42 which was painted only on the interior. A comparison of target irradiance for the unfinished wardrobe in test 41 is made with the fire-retardant painted wardrobe of test 44 in figure 118. This figure shows that the unfinished wardrobe

had a much smaller peak radiant flux when compared to the wardrobe with two coats of fire-retardant paint. Part of this may be attributed to the fact that the painted wardrobe remained intact longer and provided a better surface for **radiating** energy where the surface of the unfinished wardrobe burned away rapidly, and the radiating surface disappeared.

Another interesting comparison of the unfinished wardrobe to the **fire-**retardant painted wardrobe is shown in figure 119. This figure shows that the fire-retardant painted wardrobe produced a **significant** quantity of smoke as compared to the unfinished wardrobe. Based on the total smoke values from table 7, the fire-retardant painted wardrobe in test 44 produced better than 5 times the smoke of the unfinished wardrobe burned in test 41.

7.2.4 Particleboard Wardrobe and Bookcase

The 19.1 mm thick particleboard wardrobe evaluated in test 61 was the heaviest piece of furniture tested with a mass of 120.33 kg. This wardrobe was filled with the fabrics described in section 2.2 and table 3. The burning wardrobe produced two heat release rate peaks. The first peak resulted from the burning closet and fabrics and the second resulted from the burning desk, shelves, and drawers on the right side of the wardrobe closet. The total heat release of 1349 MJ was the greatest quantity measured throughout the 28 tests in this project. This result was not a surprise since the specimen mass was large. The large spike on the rate of mass loss figure 122 at approximately 900 seconds resulted from the side wall and the door of the wardrobe closet falling down onto the load cell platform. The peak target irradiance occurred shortly after this structural failure when flames extended from the wardrobe's

back surface through the desk and shelves. The total smoke produced for this test was high when compared to the peak particulate conversion. This is again attributable to the specimen mass.

The 12.7 mm plywood bookcase burned in test 62 ignited when it was exposed to the 50 **kW** gas flame. However , open flaming only lasted for 60 seconds after the 200 second exposure flame period. The peak heat release rate of 28 **kW** occurred during the period of pilot flame exposure. See figure 126. Other data from this test are not available because the values were too small to measure.

Table 7. Test Results on Wardrobe Closets and Bookcase

Item	Test NO.	Specimen Mass (kg)	Heat Release Rate (kW)		Total Heat Release (MJ)	Peak Mass LOSS Rate (g/s)	Average Heat of Combustion (MJ/kg)	Peak Target Irradiance (kW/M ²)	Smoke Peak Particulate Conversion (%)	Total Smoke Produced (g)	Peak Carbon Monoxide (g/s)	Remarks
			Initial Peak	Secondary Peak								
Metal Wardrobe	15	41.40	770	N	70	43.2	14.8	(1)	(1)	(1)	0.7	Fabric load was 3.18 kg of rags.
Metal Wardrobe	21	40.80	270	N	52	18.8	18.8	4.0	3.7	15	0.3	
Plywood Wardrobe 12.7 mm (1/2 in) Unfinished	39	68.50	3300	1500	863	198.0	14.3	47.5	0.5	96	1.9	Doors of wardrobe fell from load platform and did not burn.
Plywood Wardrobe 12.7 mm (1/2 in) Unfinished	40	68.32	3500	3200	1067	99.0 ⁽²⁾	(2)	54.2	1.1	119	1.6	
Plywood Wardrobe 12.7 mm (1/2 in) Unfinished	43	67.62	3100	2600	1068	198.1	14.9	66.8	1.3	131	2.3	
Plywood Wardrobe 3.2 mm (1/8 in) Unfinished	41	36.00	6400	N	590	301.3	16.9	19.5	0.7	67	3.1	
Plywood Wardrobe 3.2 mm (1/8 in) 1 Coat Fire Retardant Paint	42	37.33	5300	N	486	249.7	15.9	25.6	2.8	146	12.6	Finished with oil base fire-retardant paint. Painted outside only.
Plywood Wardrobe 3.2 mm (1/8 in) 2 Coats Fire Retardant Paint	44	37.26	2900	N	408	177.5	14.2	39.1	3.3	337	7.7	Finished with latex fire-retardant paint. Painted inside and out.
Particleboard Wardrobe 19.1 mm (3/4 in)	61	120.33	1900	1300	1349	99.5	17.5	20.5	0.7	200	1.2	
Plywood ⁽³⁾ Bookcase 12.7 mm (1/2 in)	62	30.39	30	N	0	(4)	(4)	(4)	(4)	(4)	0.0	Bookcase exposed to 50 kW gas flame for 200 s.

N - No second peak.

(1) - Data not taken during the test.

(2) - Load cell was not working properly.

(3) - We bookcase ignited but did not continue to burn after the exposure flame was removed.

(4) - Data not available because mass loss, irradiance and smoke were too small to measure.

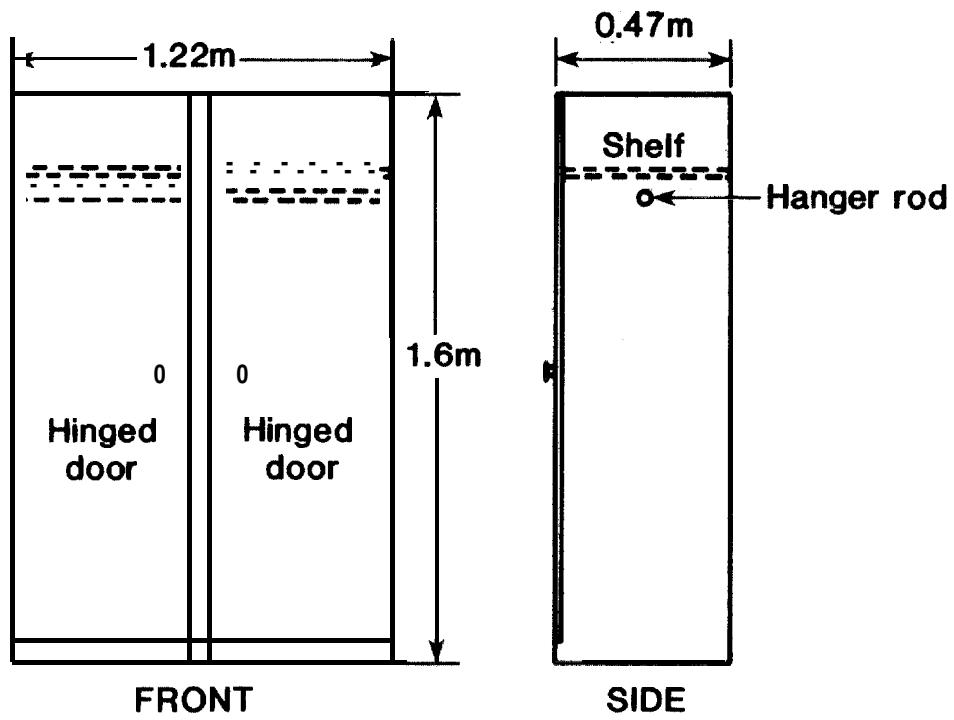
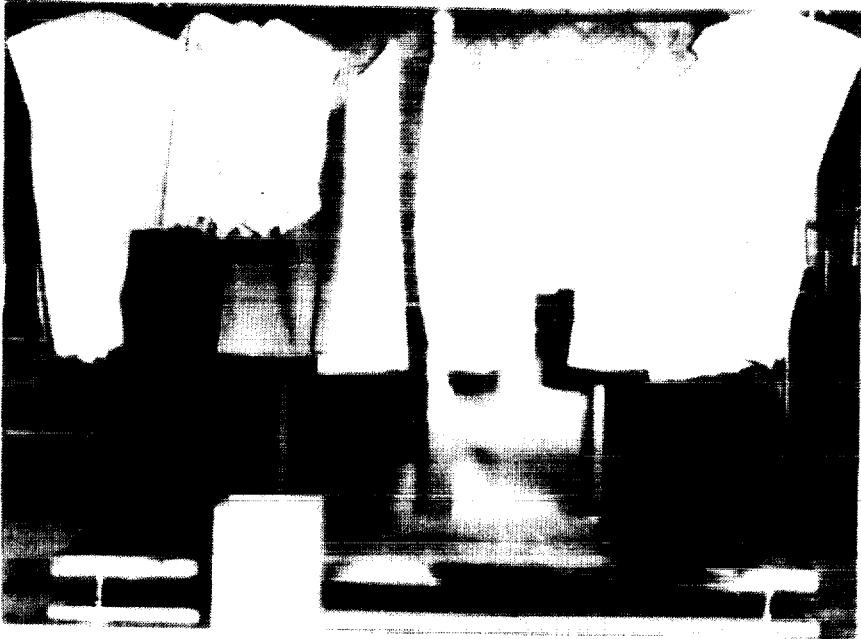

Figure 83. Photograph of metal wardrobe and fabric load and sketch of metal wardrobe

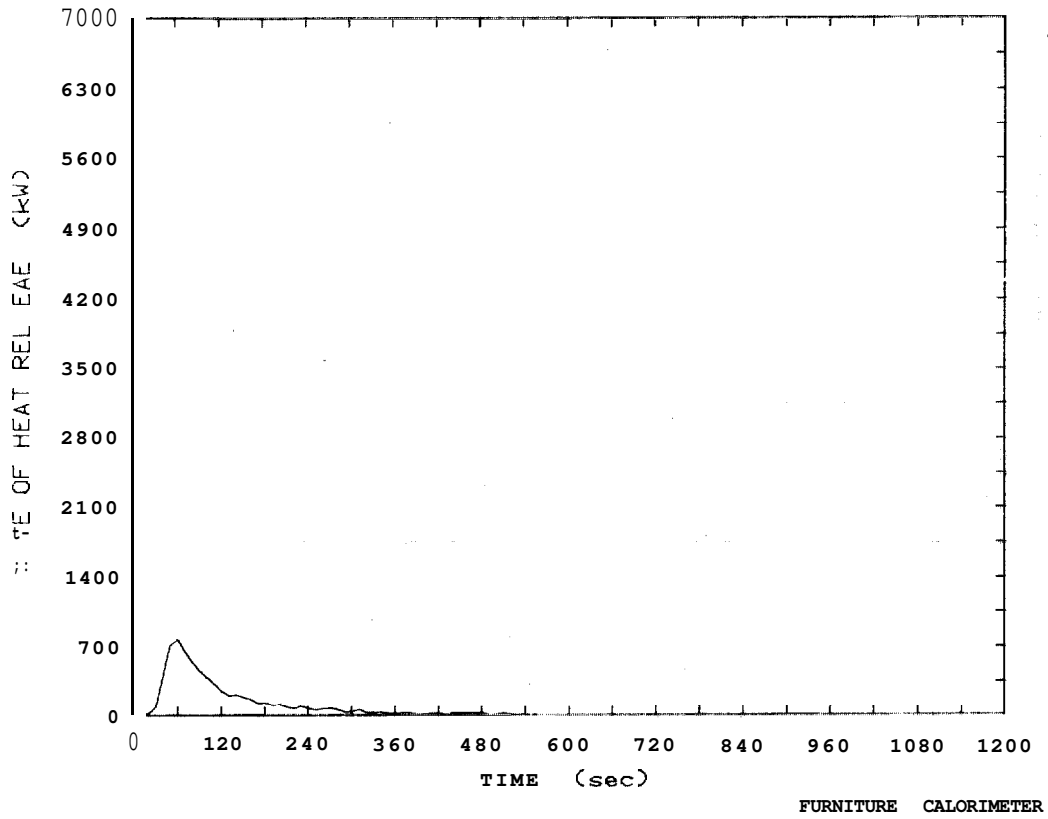

Figure 84. Rate of heat release plot for metal wardrobe, Test 15

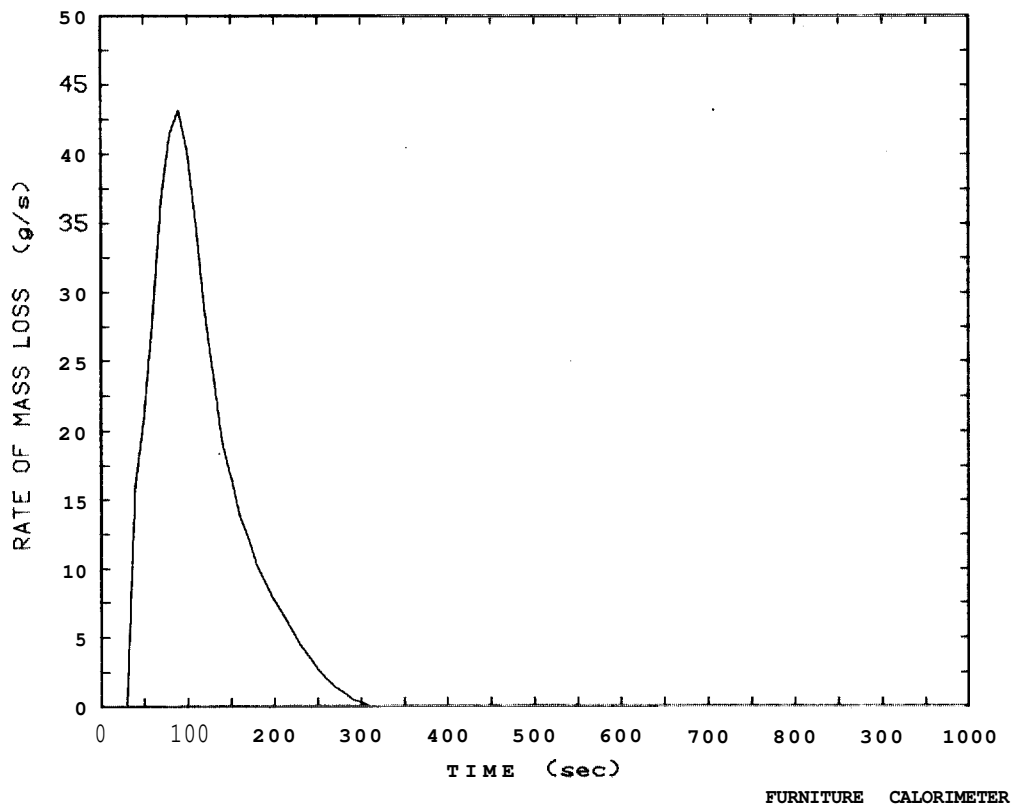

Figure 85. Rate of mass loss plot for metal wardrobe, Test 15

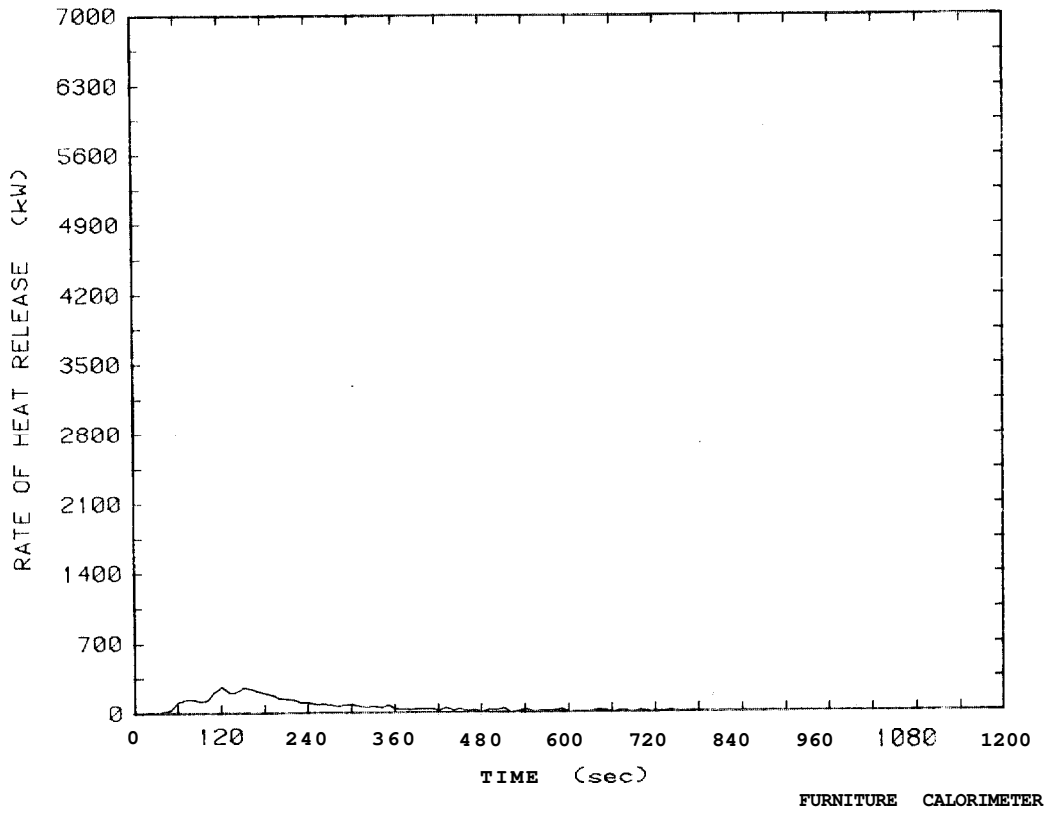

Figure 86. Rate of heat release plot for metal wardrobe Test 21

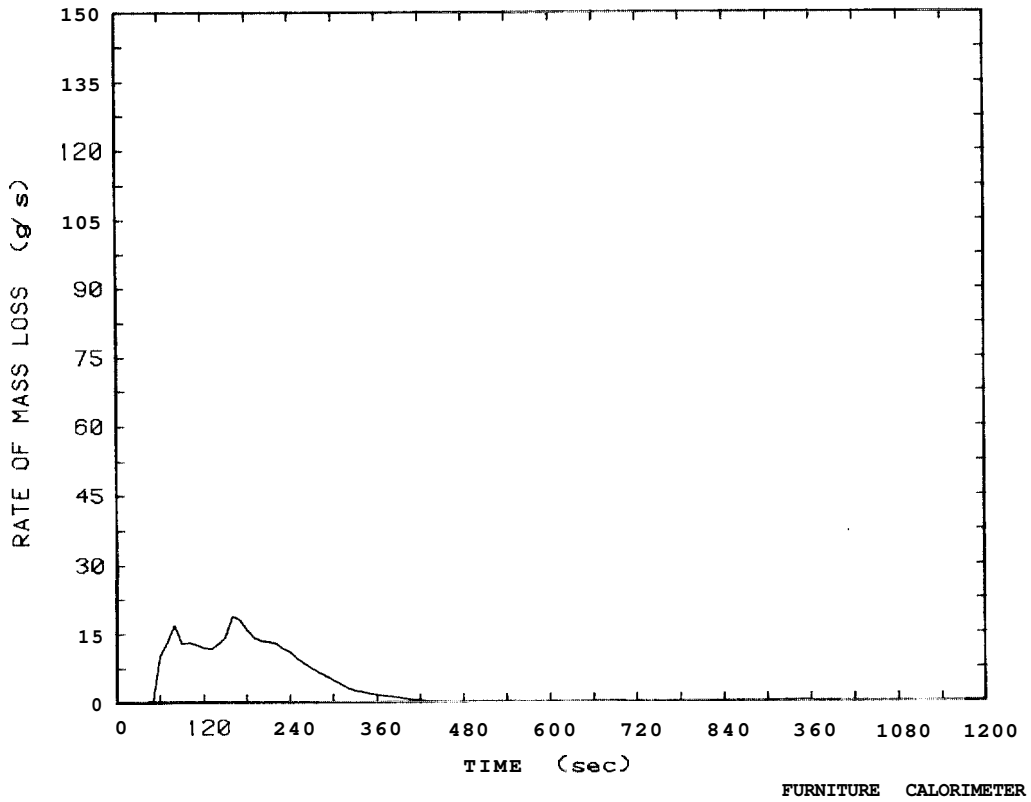

Figure 87. Rate of mass loss plot for metal wardrobe Test 21

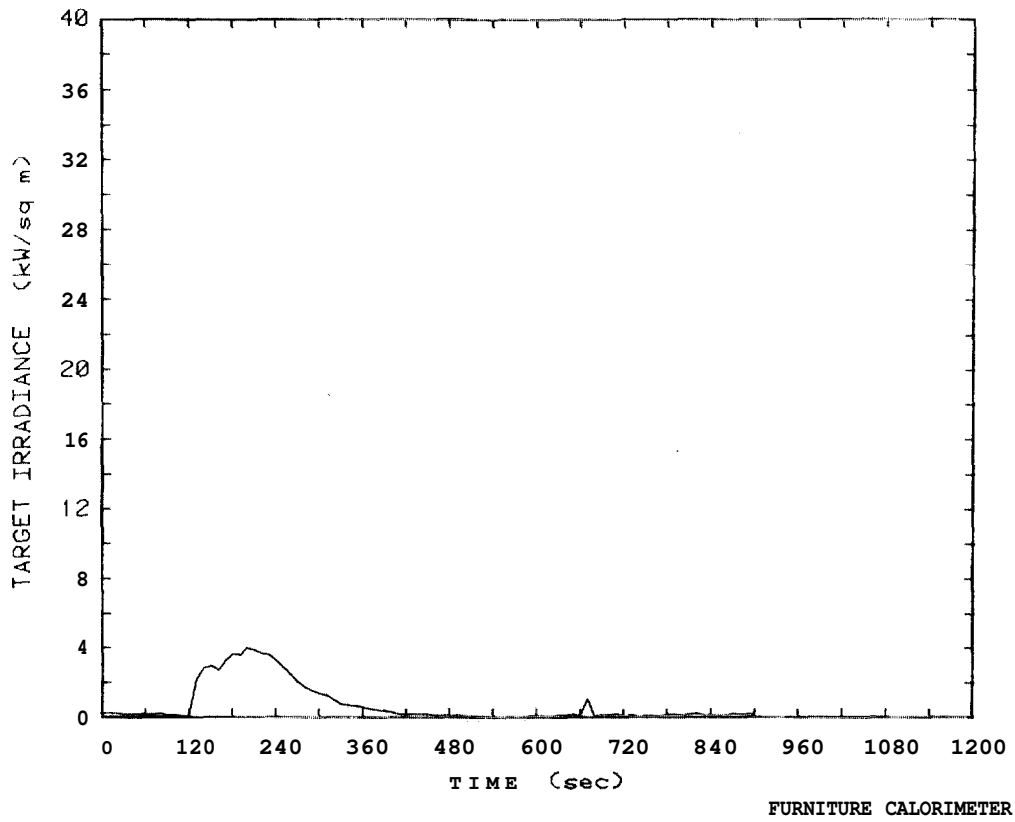

Figure 88. Target irradiance plot for metal wardrobe, Test 21

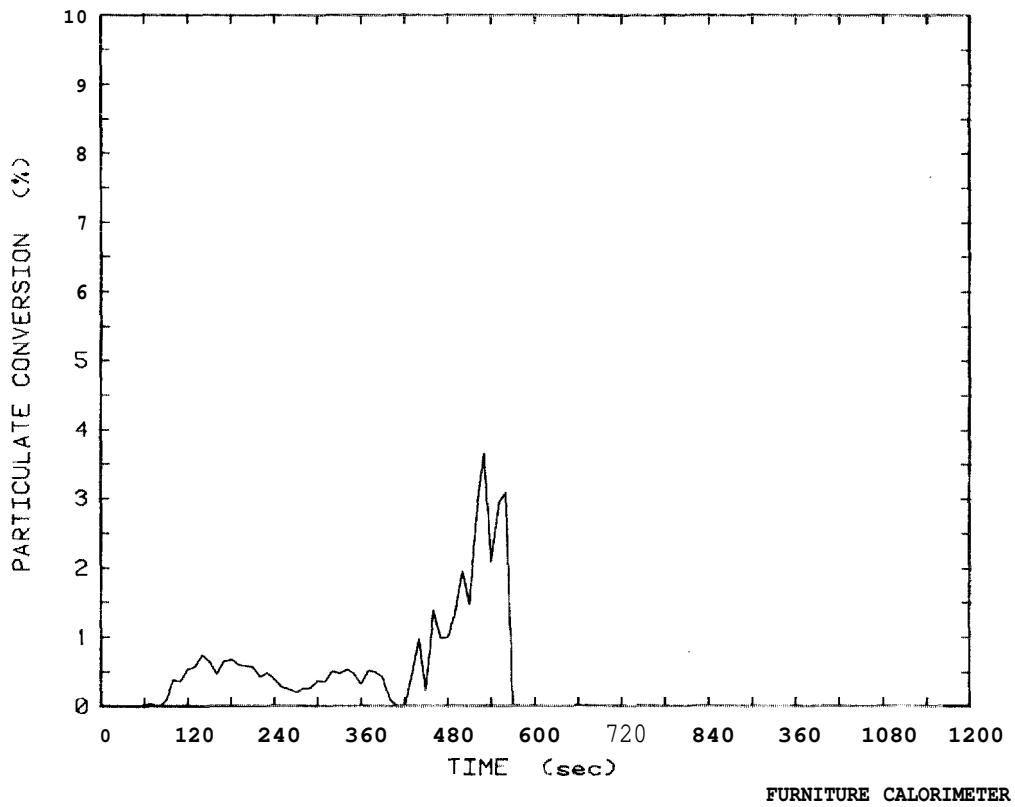

Figure 89. Smoke particulate conversion plot for metal wardrobe, Test 21

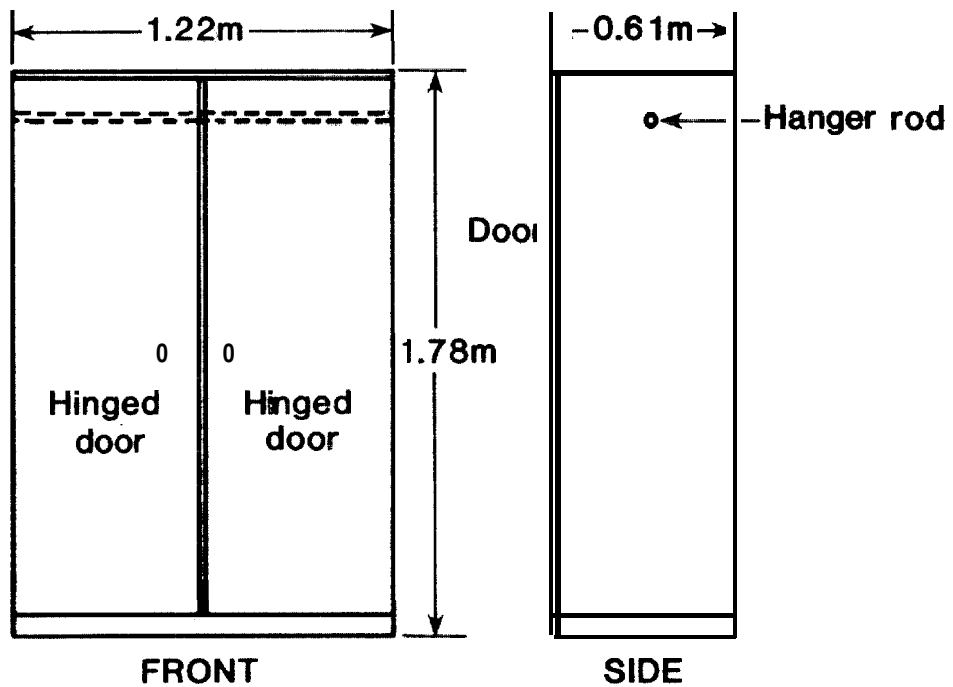
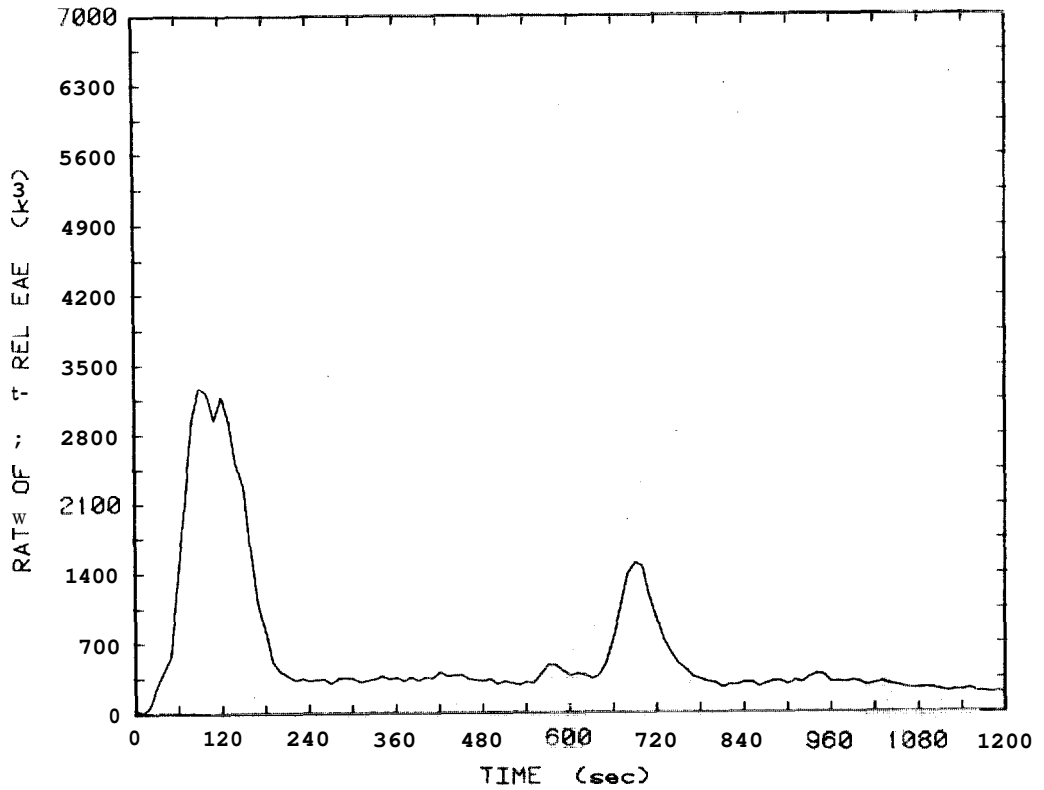
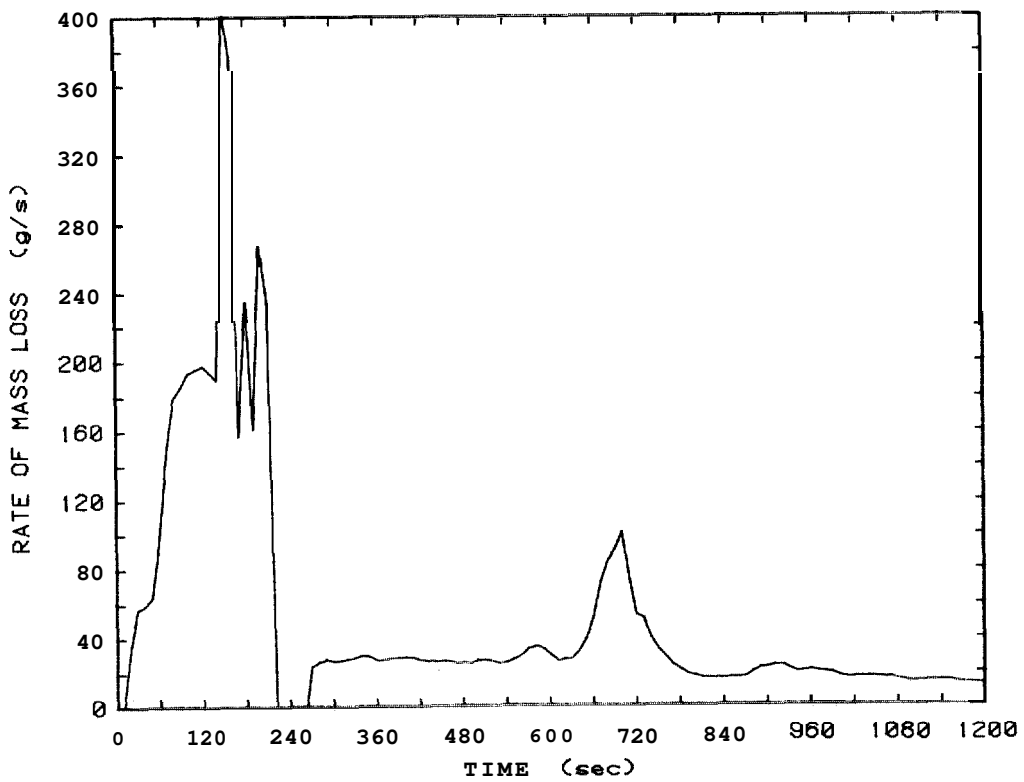

Figure 90. Photograph and sketch of 12.7 mm plywood wardrobe



FURNITURE CALORIMETER

Figure 91. Rate of heat release plot for 12.7 mm plywood wardrobe, Test 39



FURNITURE CALORIMETER

Figure 92. Rate of mass loss plot for 12.7 mm plywood wardrobe, Test 39

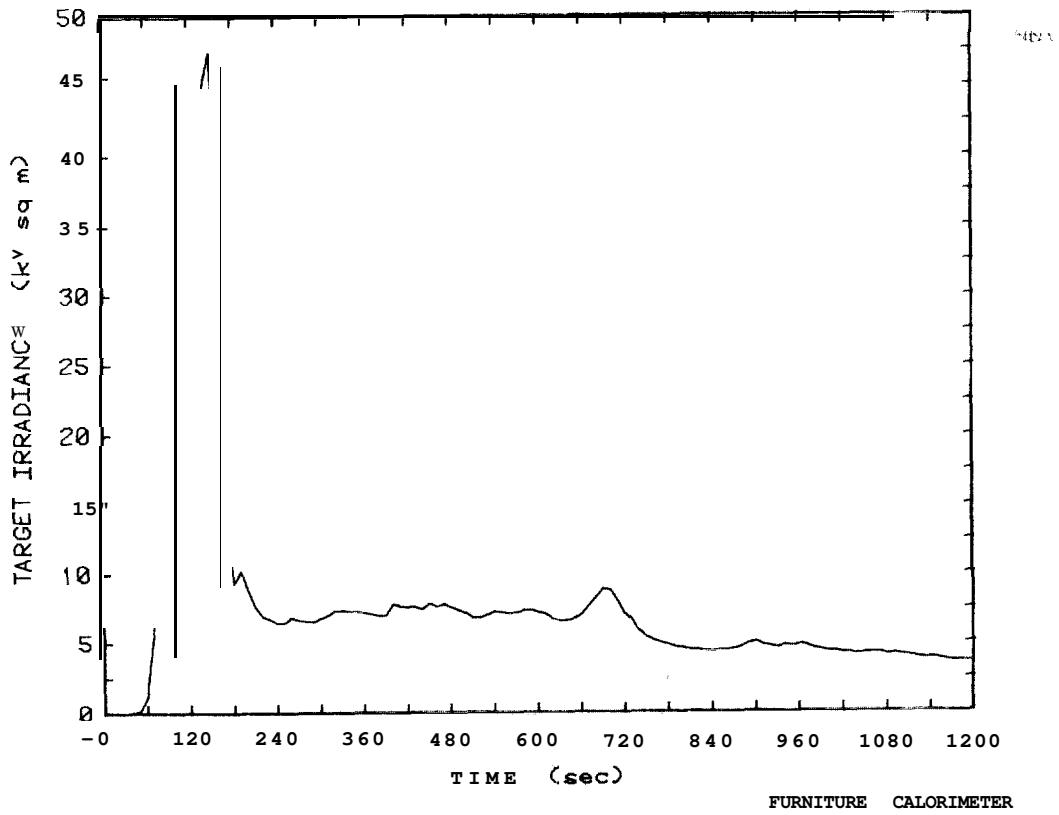

Figure 93. Target irradiance plot for 12.7 mm plywood wardrobe Test 39

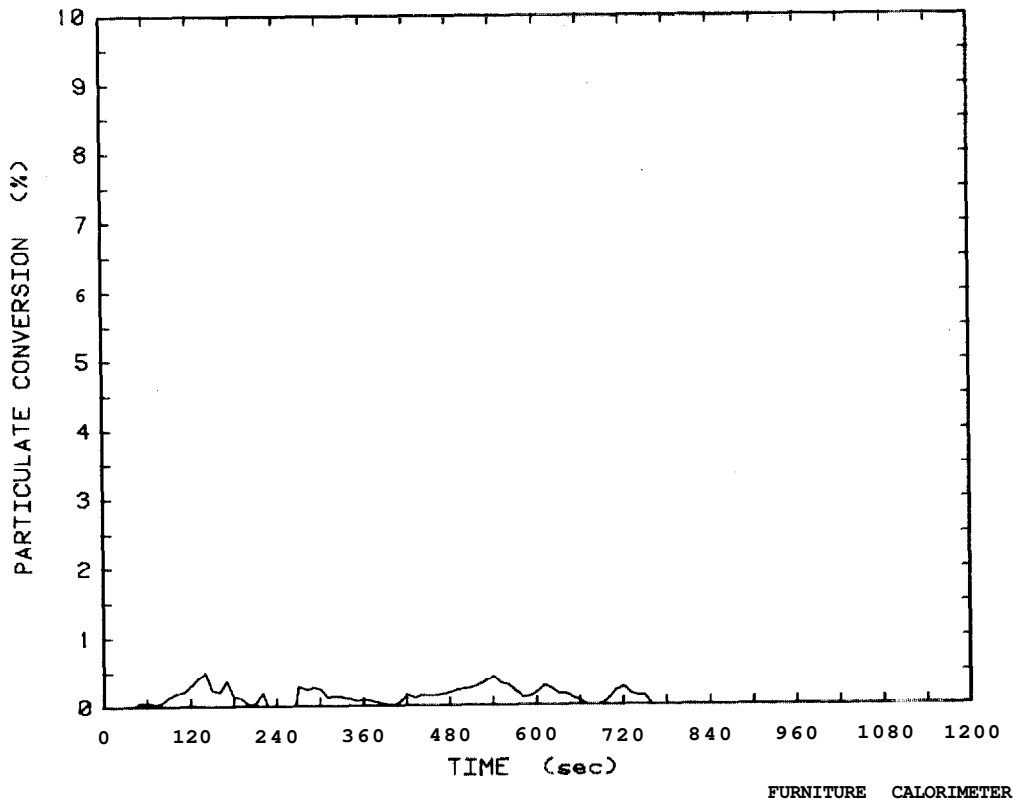

Figure 94. Smoke particulate conversion plot for 12.7 mm plywood wardrobe, Test 39

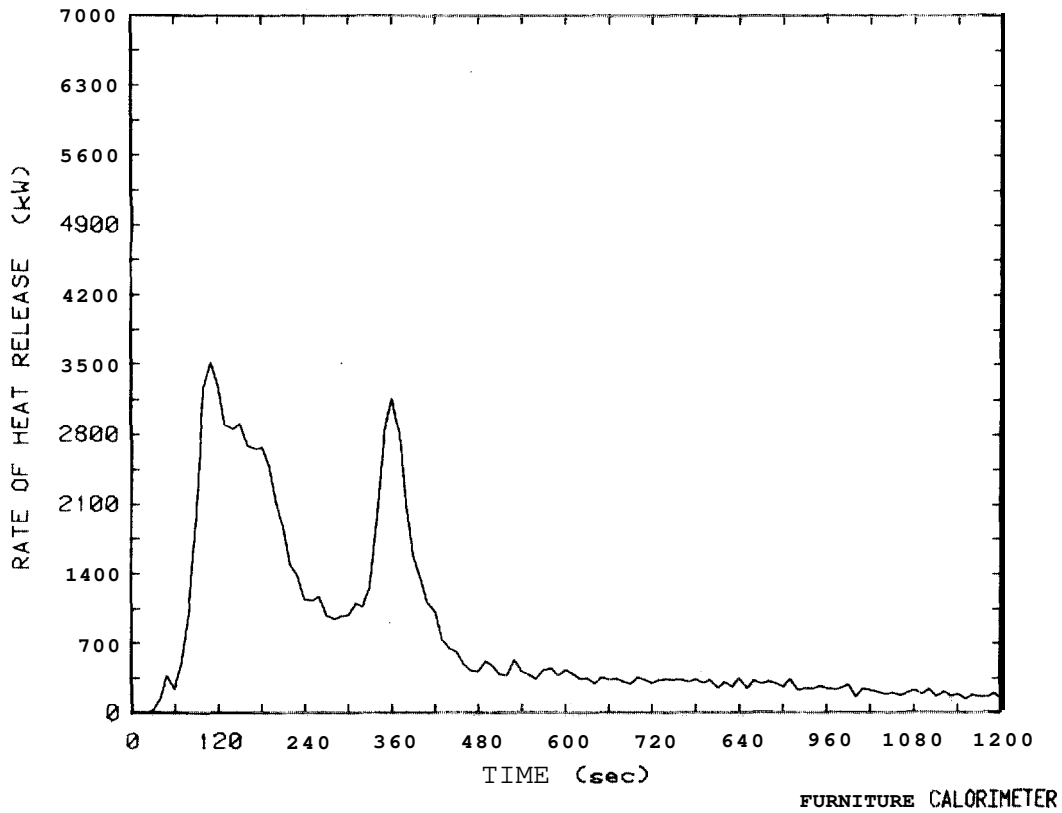

Figure 95. Rate of heat release plot for 12.7 mm plywood wardrobe, Test 40

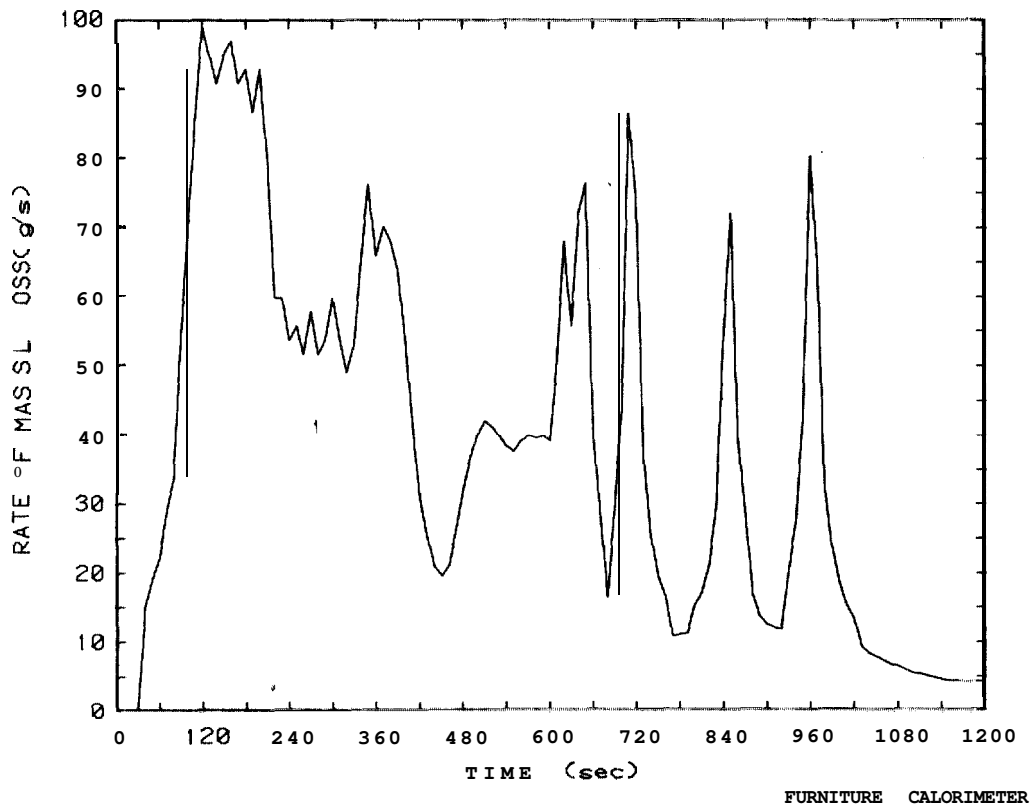

Figure 96. Rate of mass loss plot for 12.7 mm plywood wardrobe, Test 40

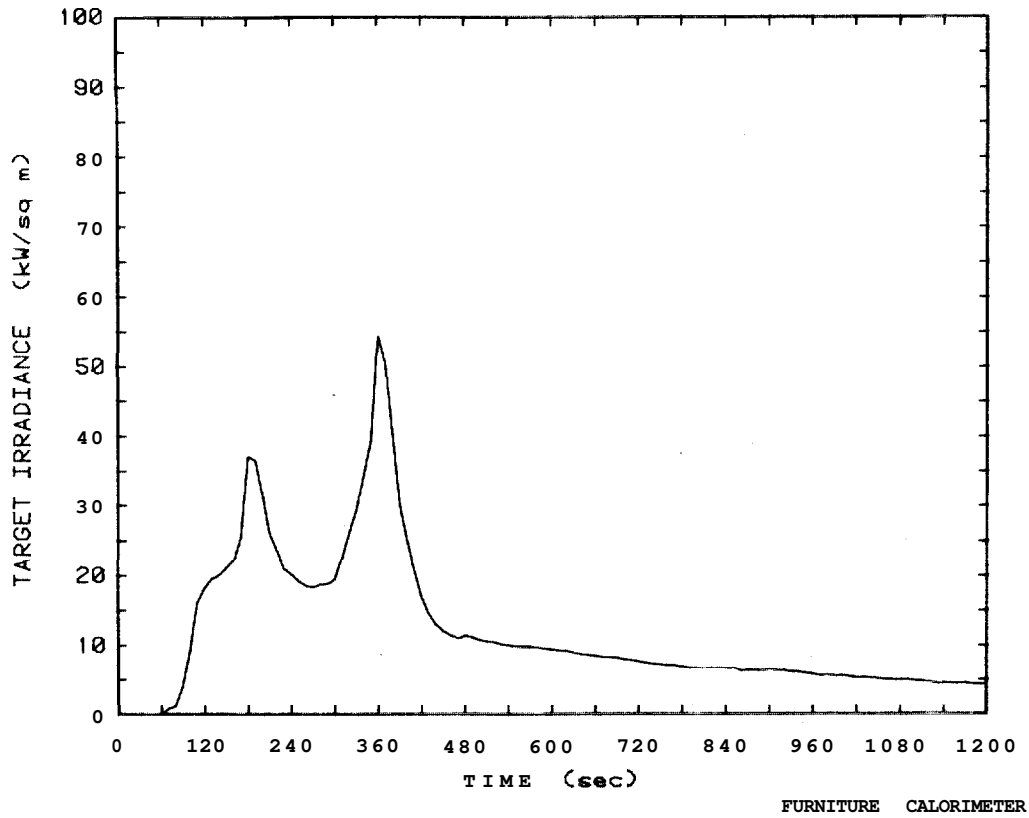

Figure 97. Target irradiance plot for 12.7 mm plywood wardrobe, Test 40

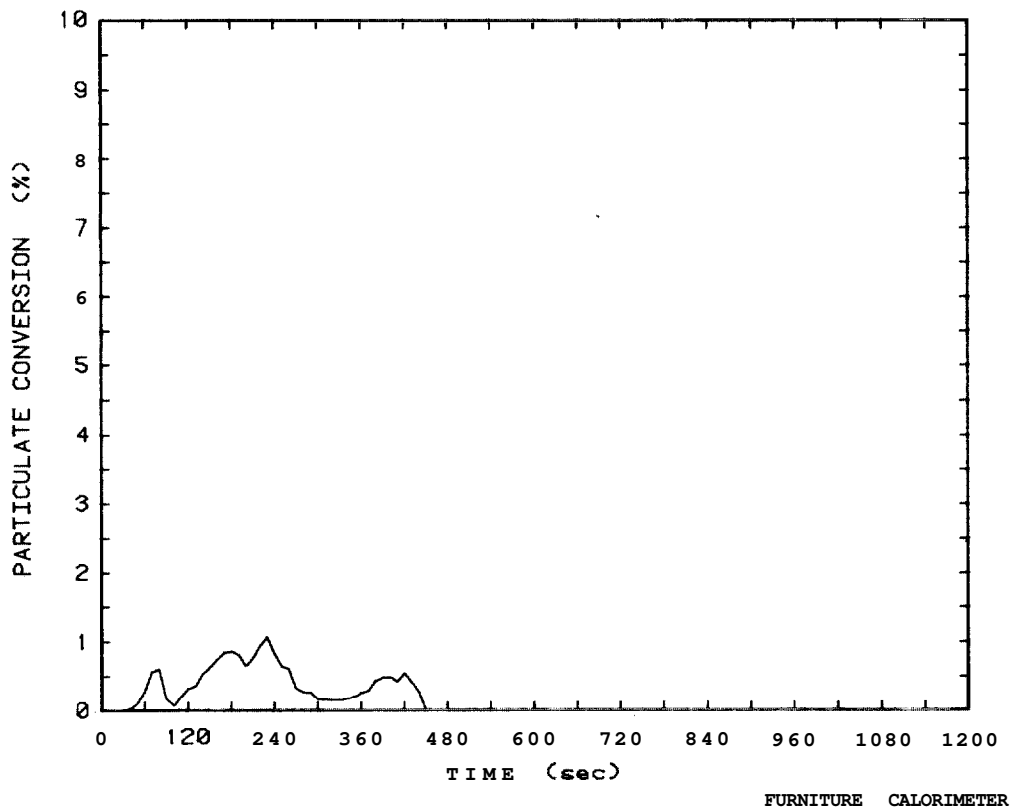

Figure 98. Smoke particulate conversion plot for 12.7 mm plywood wardrobe, Test 40

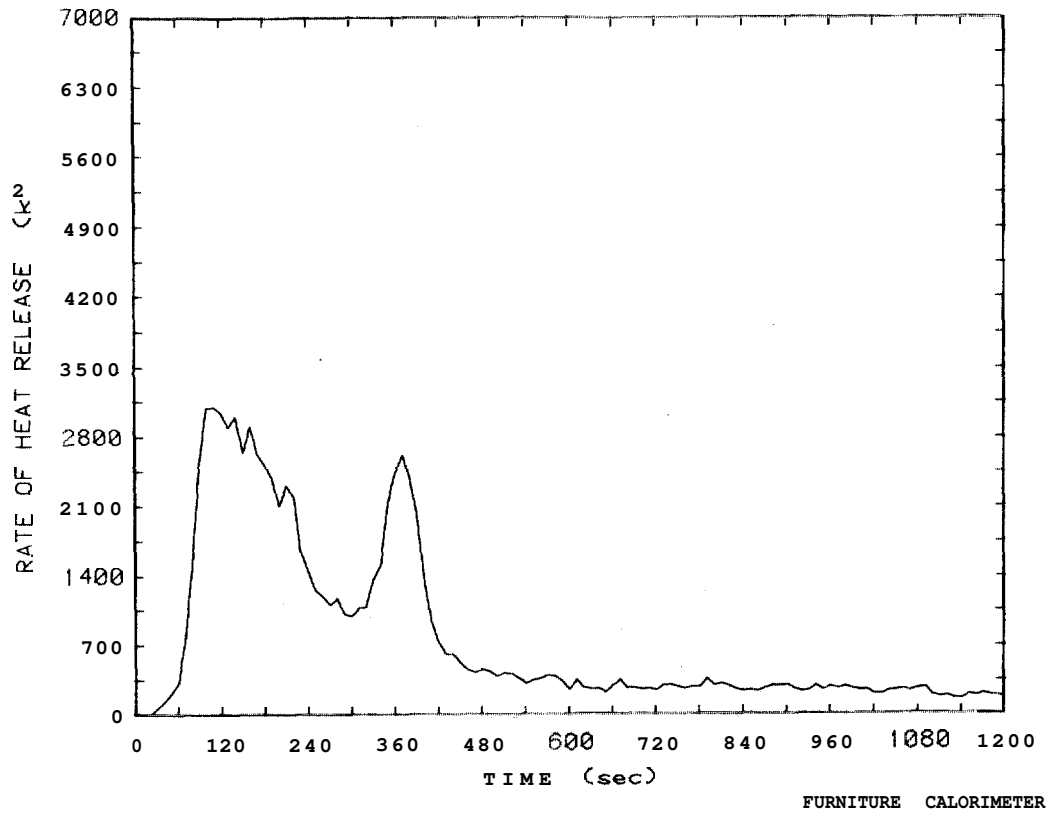

Figure 99. Rate of heat release plot for 12.7 mm plywood wardrobe, Test 43

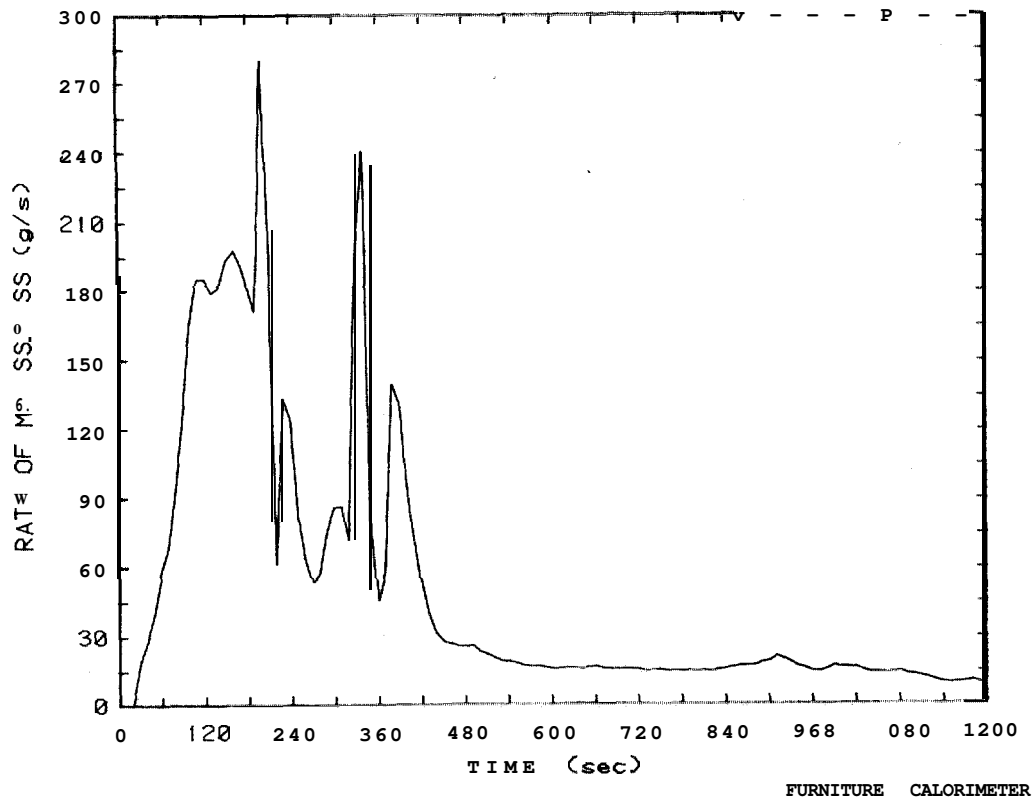

Figure 100. Rate of mass loss plot for 12.7 mm plywood wardrobe, test 43

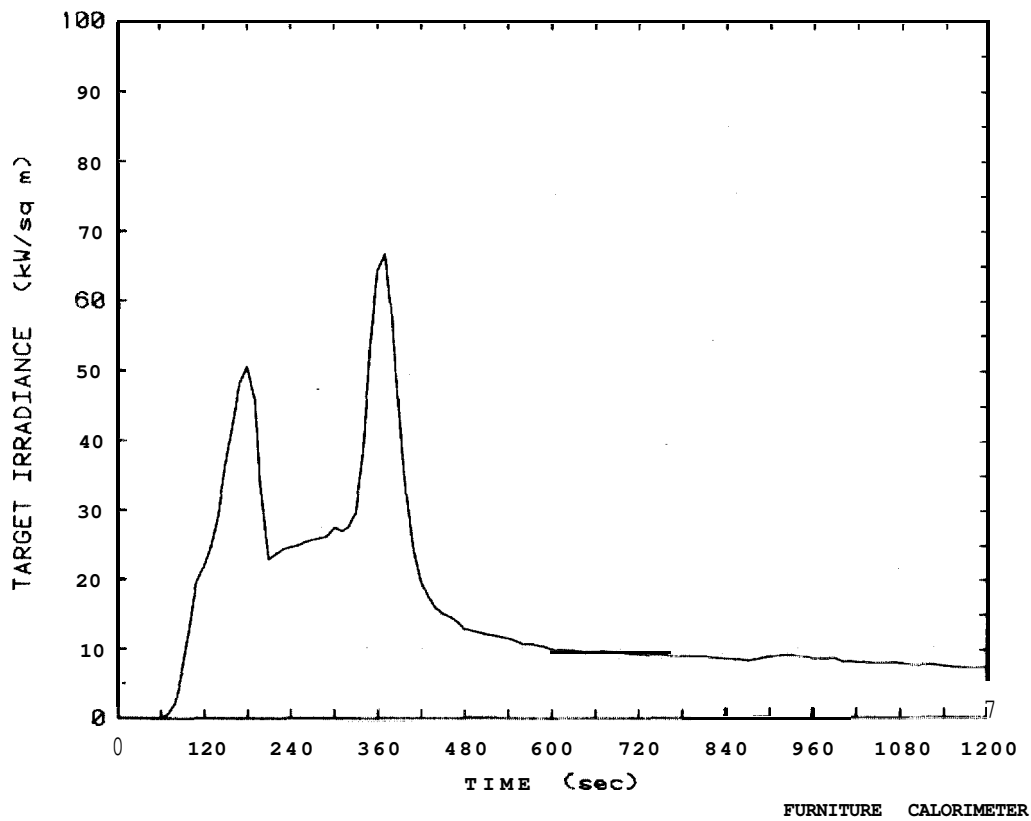

Figure 101. Target irradiance plot for 12.7 mm plywood wardrobe, Test 43

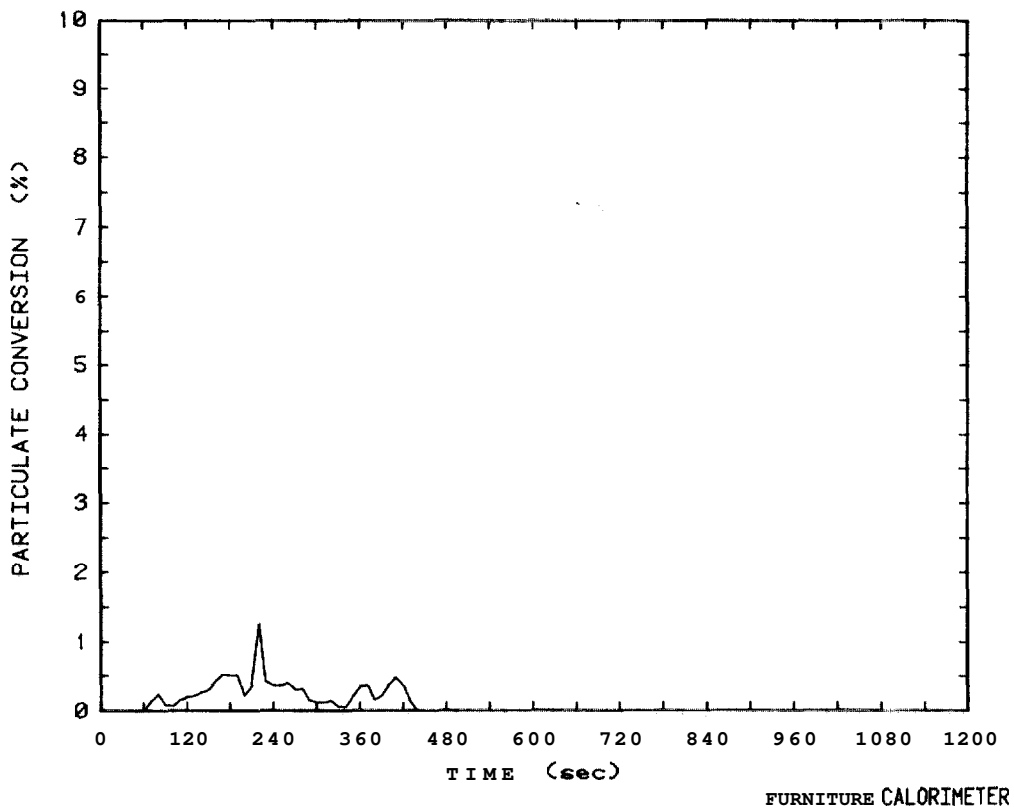

Figure 102. Smoke particulate conversion plot for 12.7 mm plywood wardrobe, Test 43

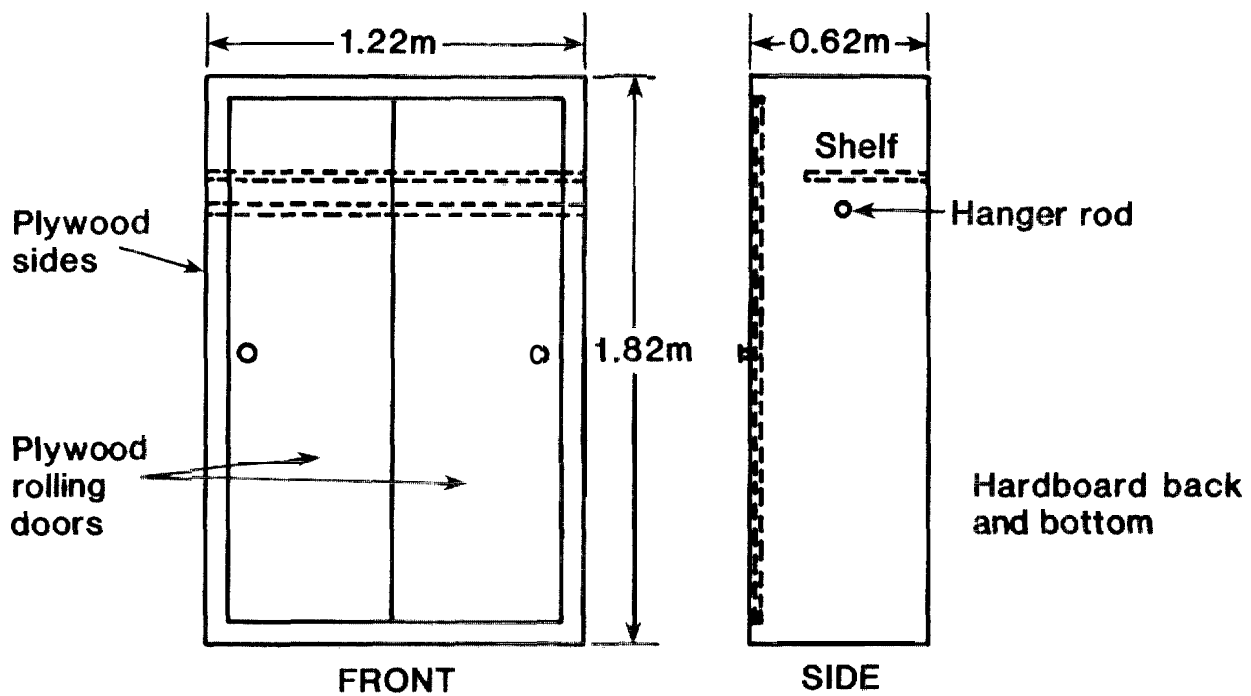

Figure .03. Photograph and sketch of 3.2 mm plywood wardrobe

PROCESSED 10/15/81 10:42:27

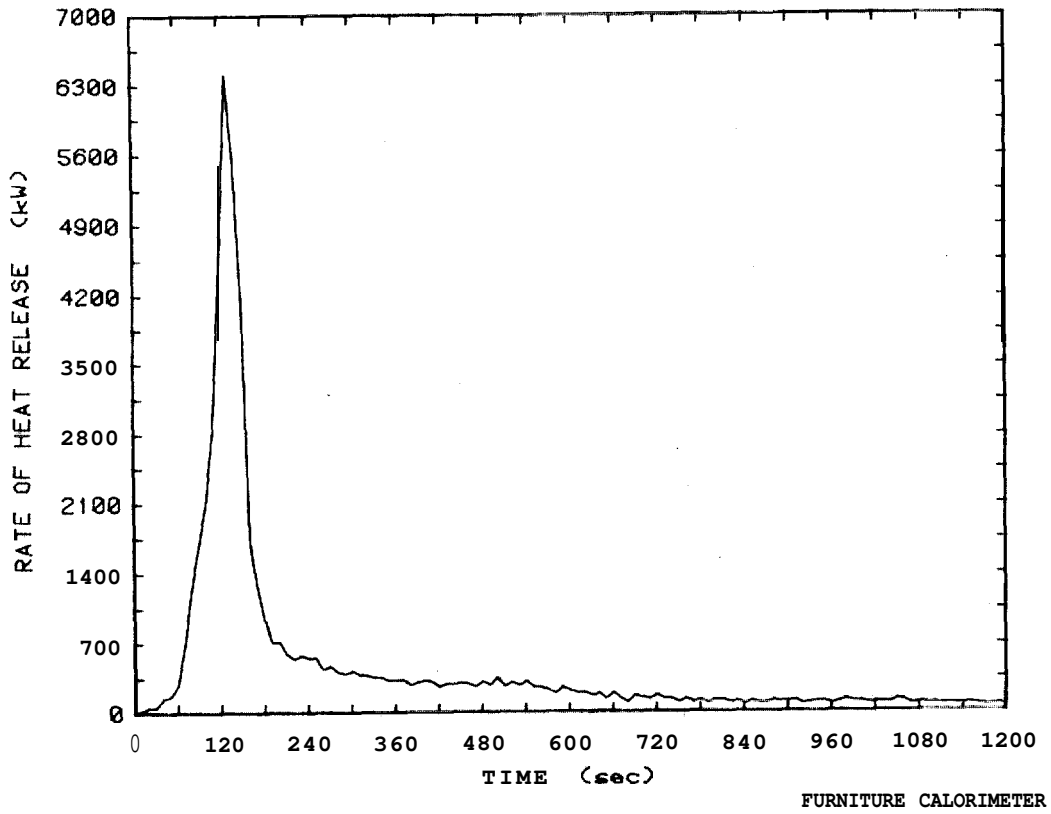

Figure 104. Rate of heat release plot for 3.2 mm plywood wardrobe, Test 41

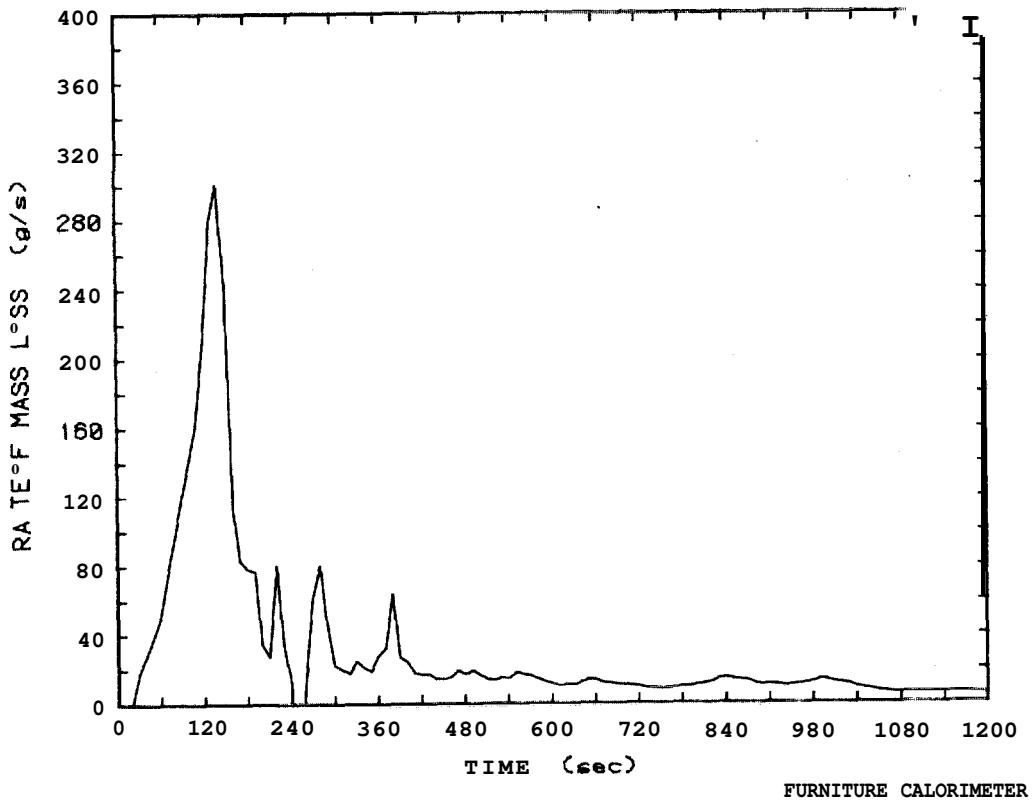

Figure 105. Rate of mass loss plot for 3.2 mm plywood wardrobe, Test 41

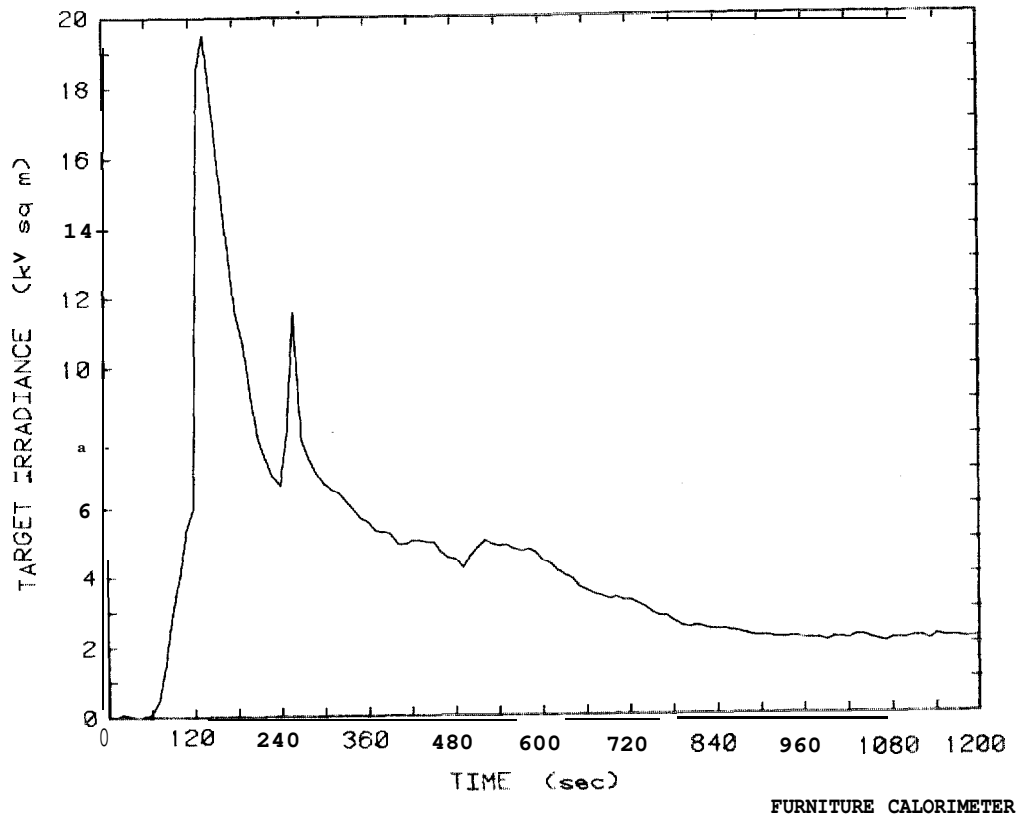

Figure 106. Target irradiance plot: for 3.2 mm plywood wardrobe, Test 41

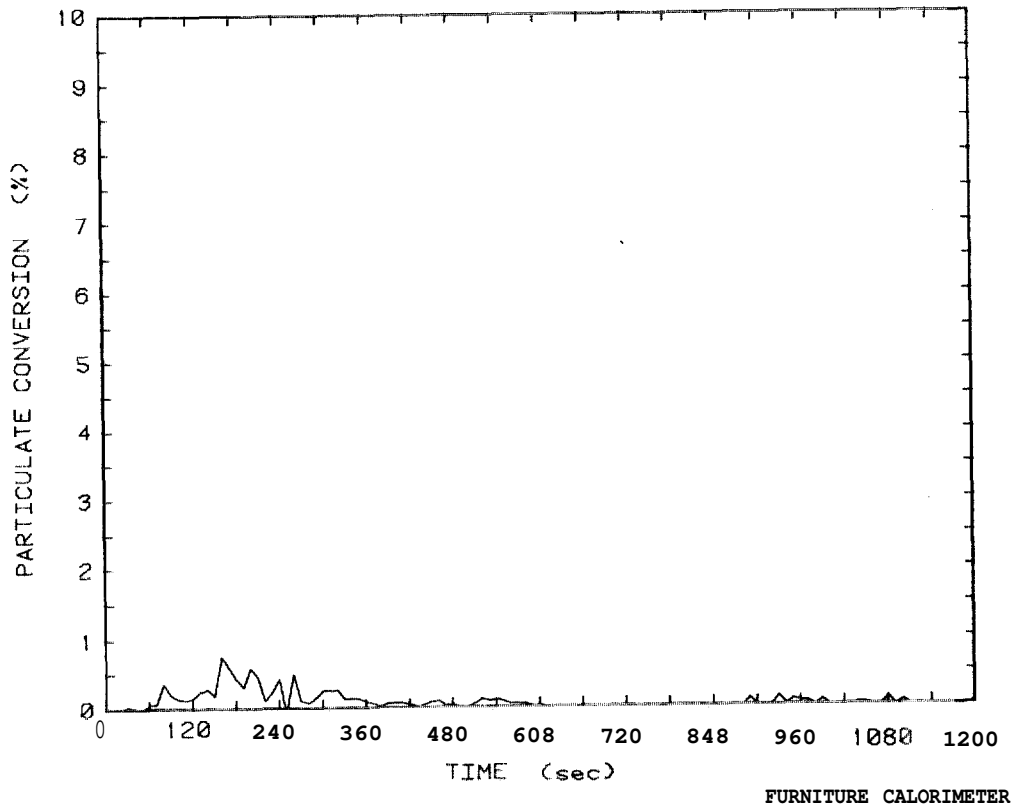

Figure 107. Smoke particulate conversion for 3.2 mm plywood wardrobe, Test 41

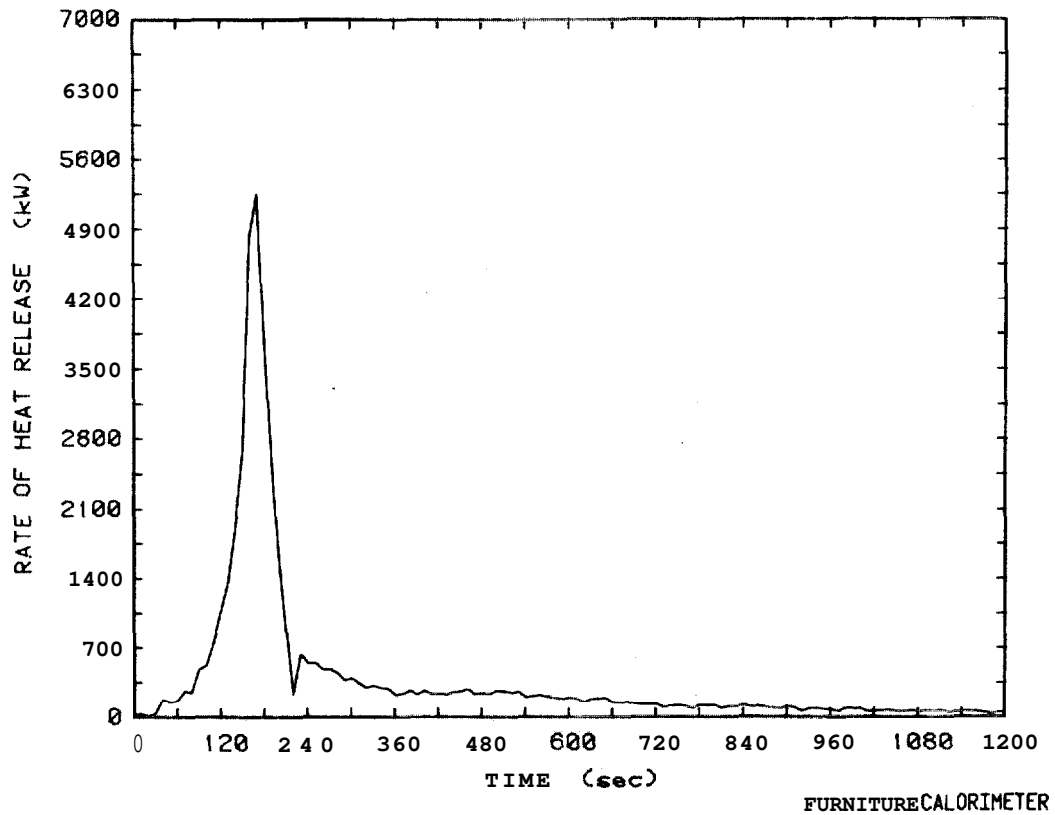

Figure 108. Rate of heat release plot for 3.2 mm plywood wardrobe painted inside with one coat of fire-retardant paint, Test 42

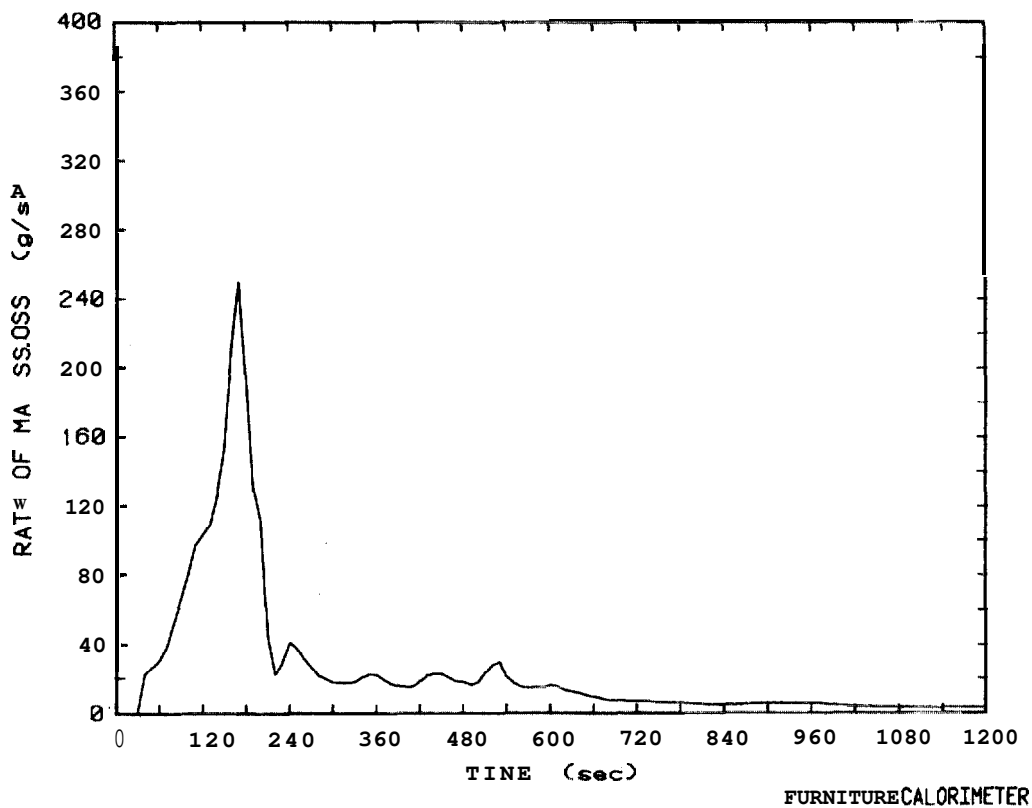

Figure 109. Rate of mass loss plot for 3.2 mm plywood wardrobe painted inside with one coat of fire-retardant paint, Test 42

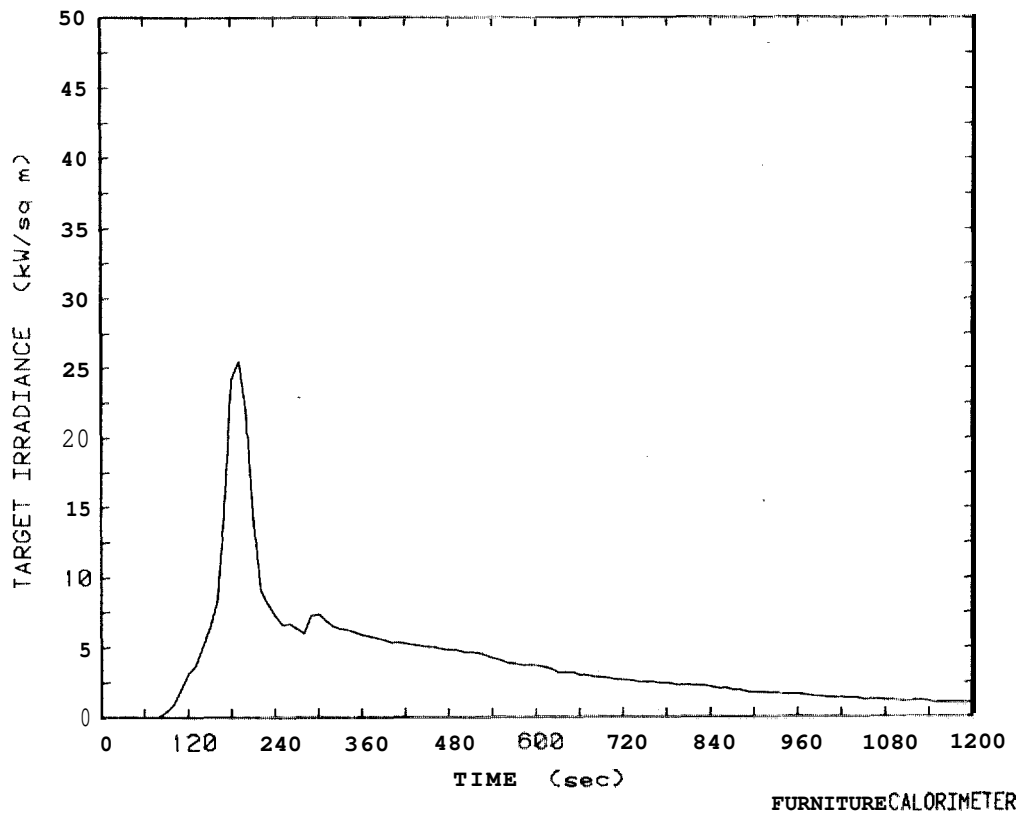

Figure 110. Target irradiance plot for 3.2 mm plywood wardrobe painted inside with one coat of fire-retardant paint, Test 42

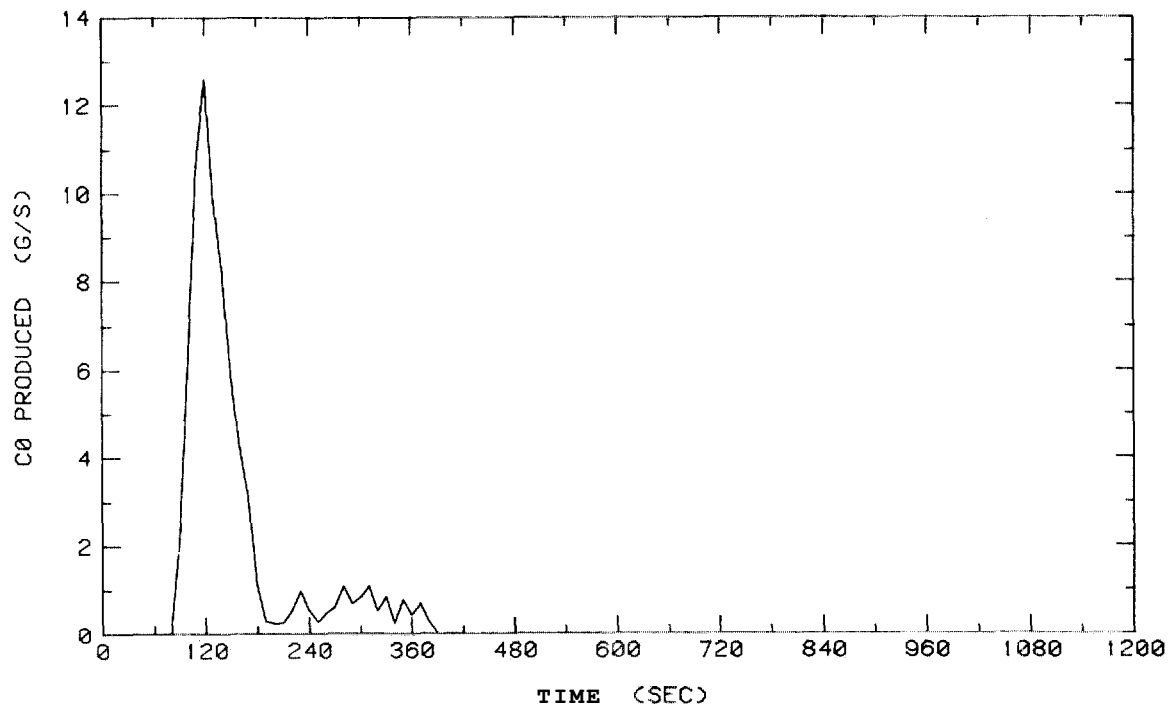

Figure 111. Carbon monoxide production plot for 3.2 plywood wardrobe painted inside with one coat of fire-retardant paint, Test 42

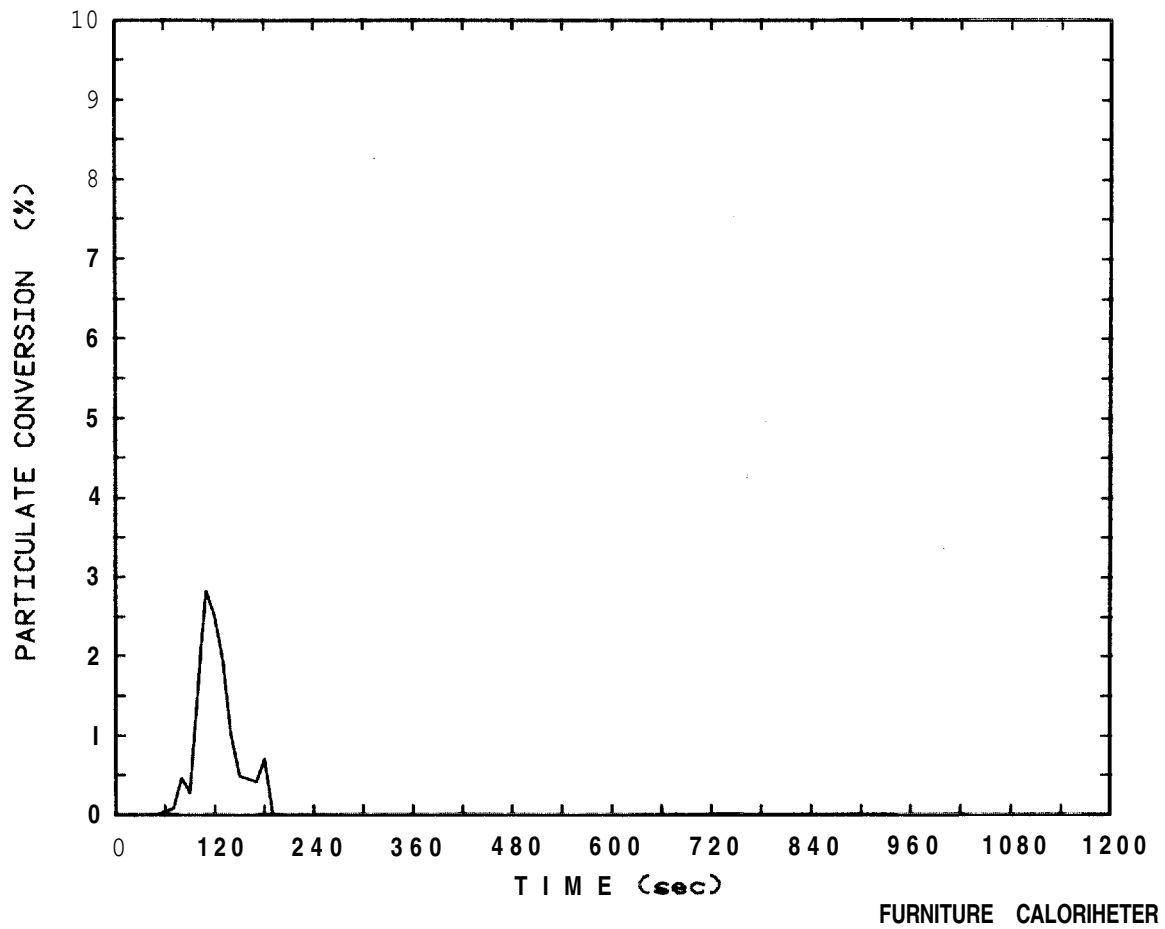
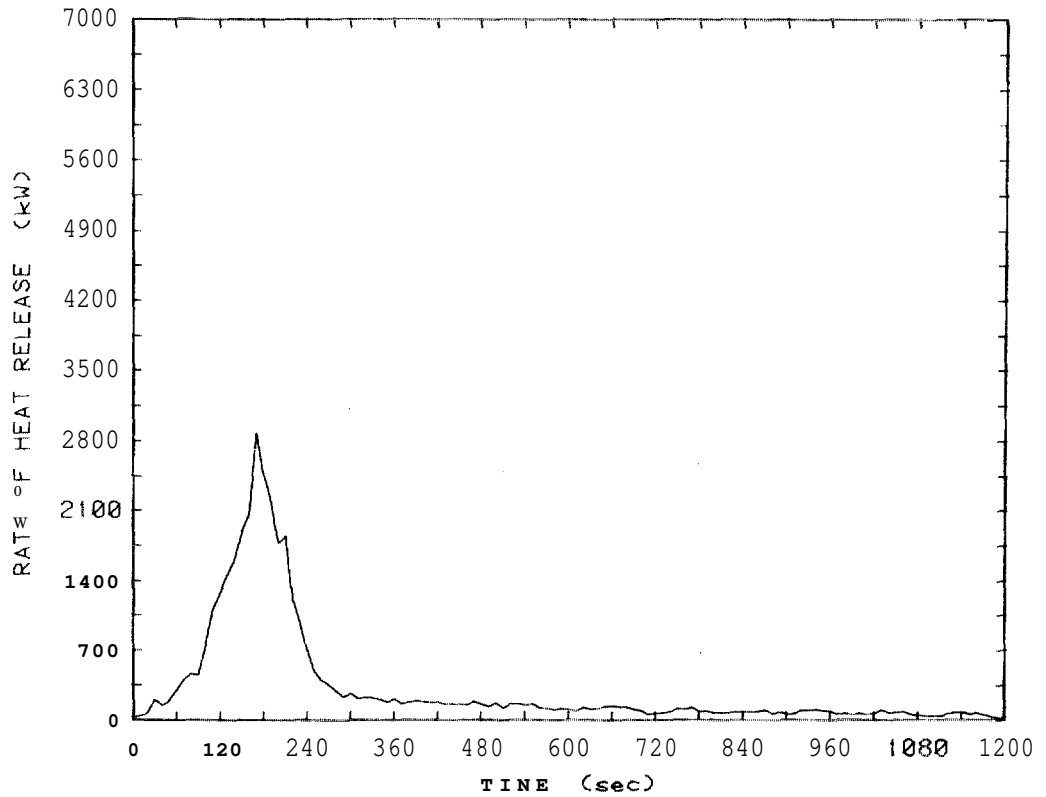
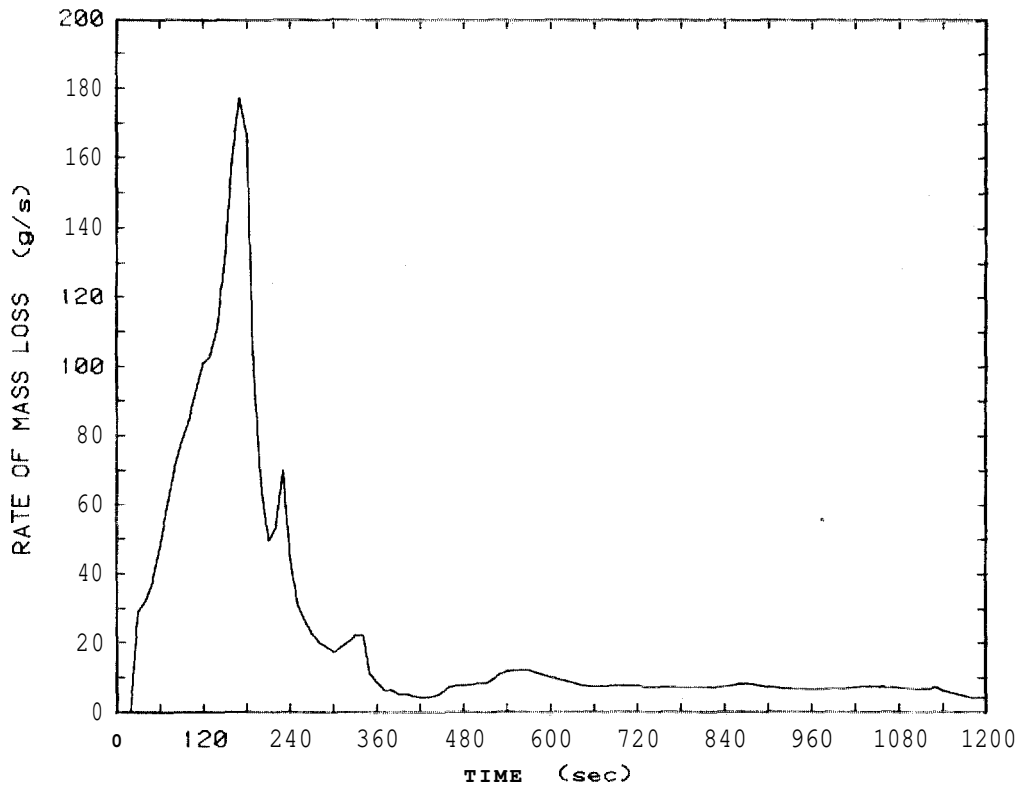

Figure 112. Smoke particulate conversion plot for 3.2 mm plywood wardrobe painted inside with one coat of fire-retardant paint, Test 42



FURNITURE CALORIMETER

Figure 113. Rate of heat release plot for 3.2 mm plywood wardrobe, painted inside and out with two coats of fire-retardant latex paint, Test 44



FURNITURE CALORIMETER

Figure 114. Rate of mass loss plot for 3.2 mm plywood wardrobe painted inside and out with two coats of fire-retardant latex paint Test 44

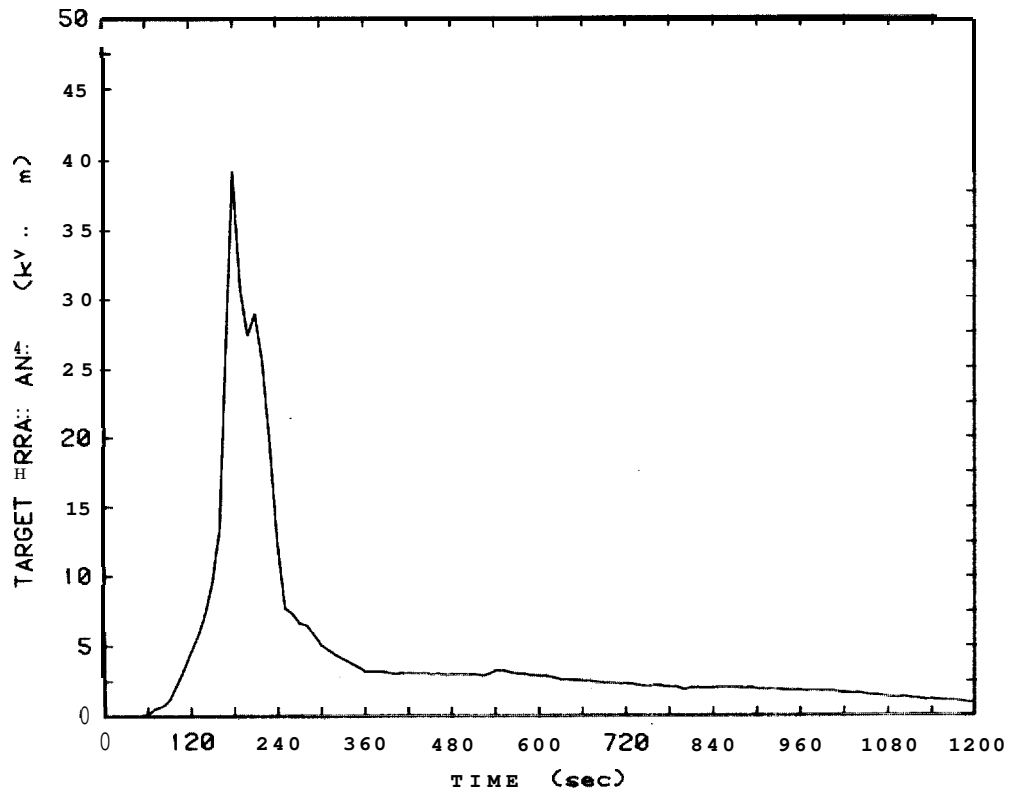

FURNITURE CALORIMETER

Figure 115. Target irradiance plot for 3.2 mm plywood painted inside and out with two coats of fire-retardant latex paint, Test 44

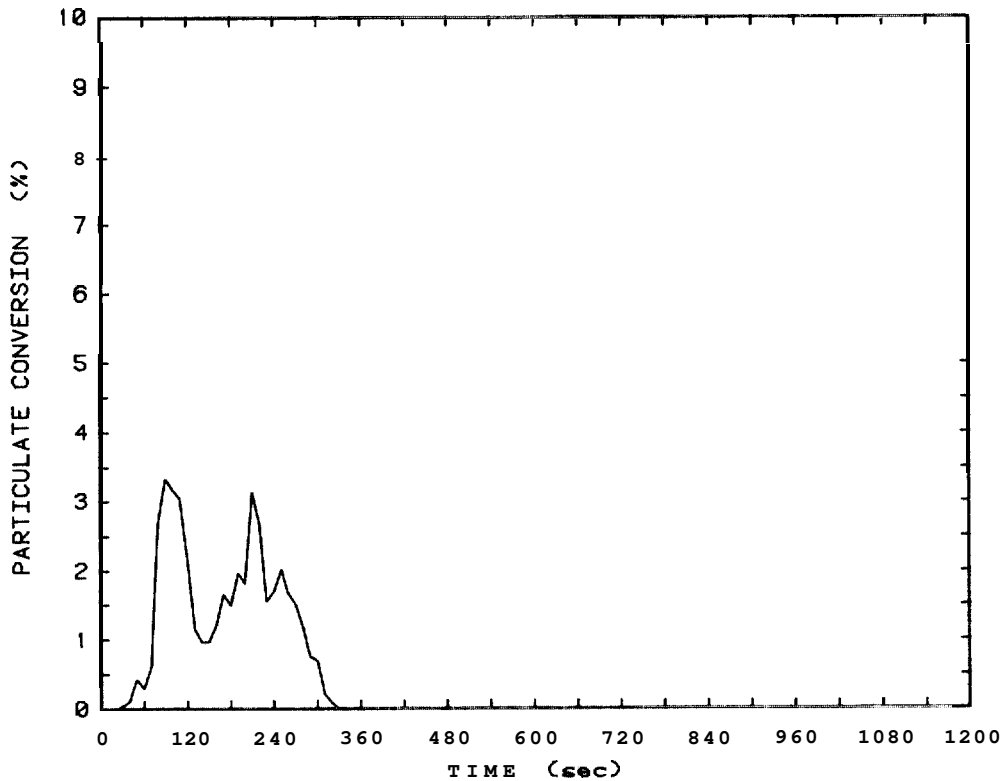

FURNITURE CALORIMETER

Figure 116. Smoke particulate conversion plot for 3.2 mm plywood wardrobe painted inside and out with two coats of fire-retardant latex paint, Test 44

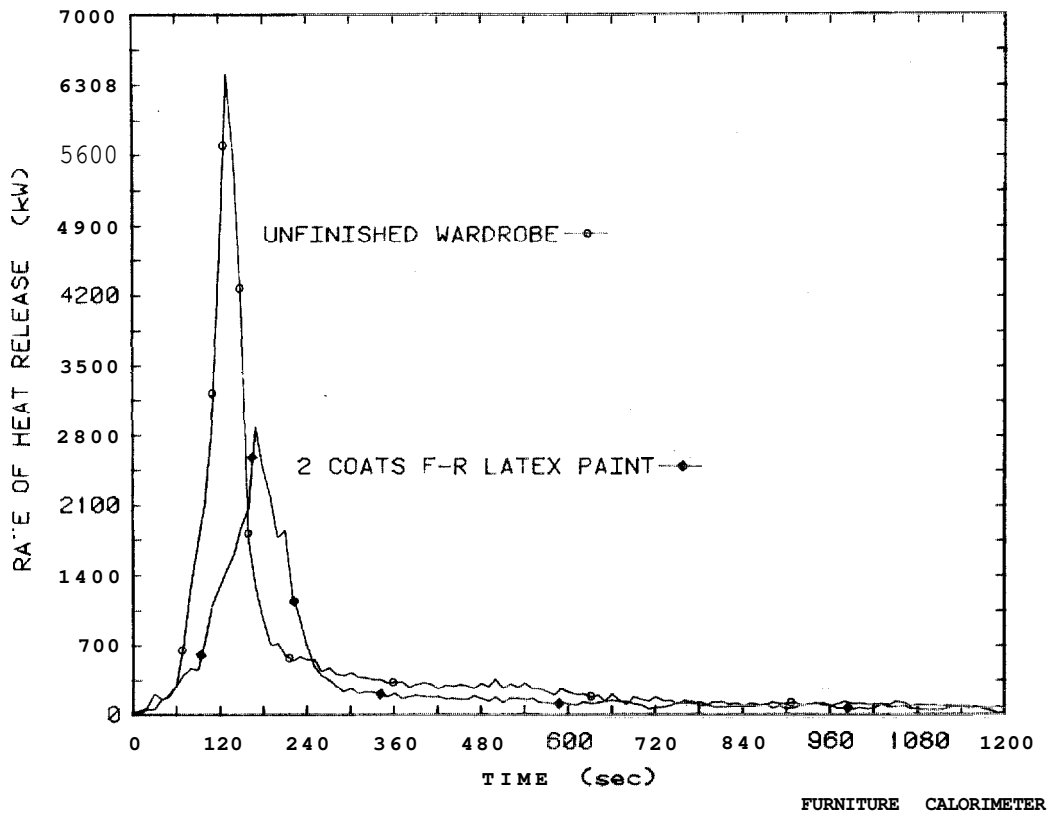

Figure 117. Comparison of heat release rates from Test 41 and Test 44

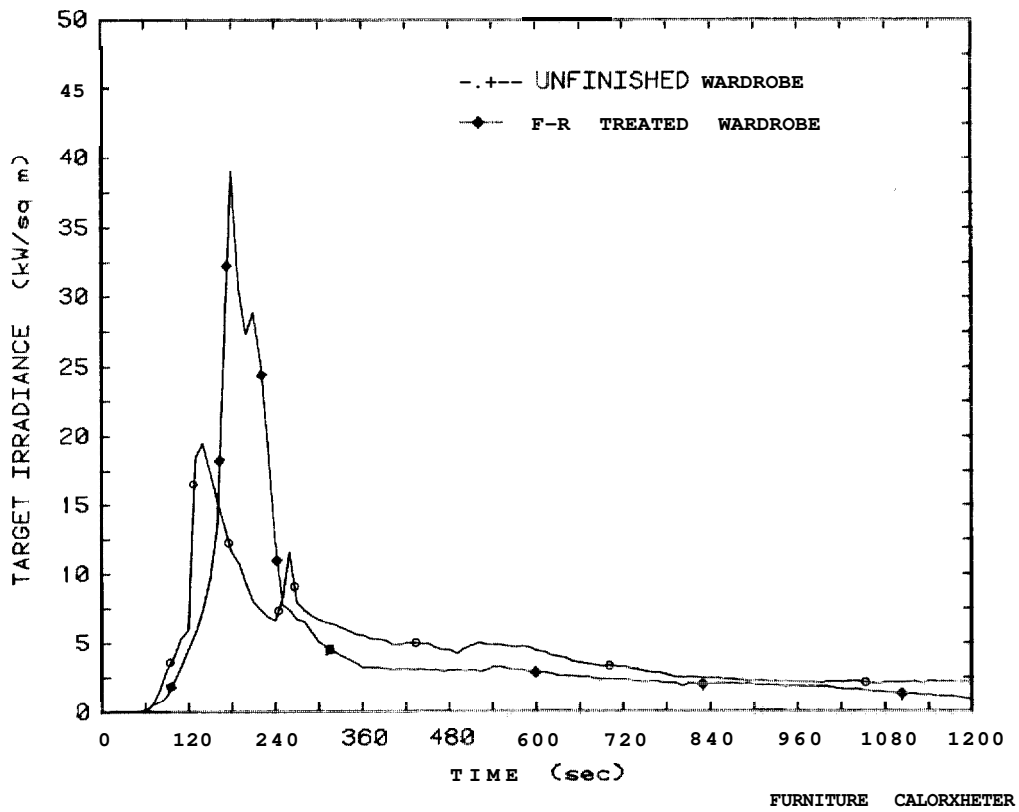

Figure 118. Comparison of target irradiances experienced in Test 41 and Test 44

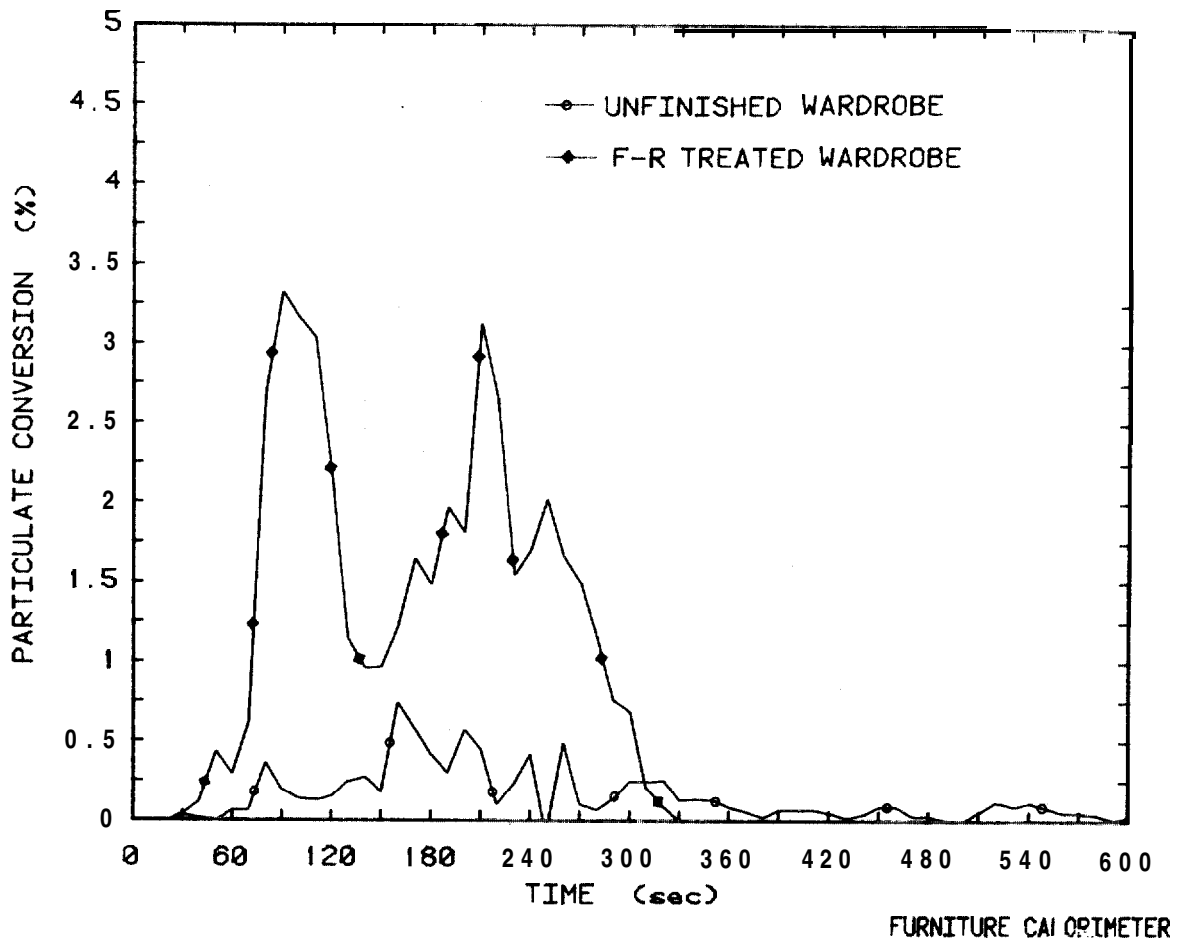

Figure 119. Comparison of smoke particulate conversion for Tests 41 and 44

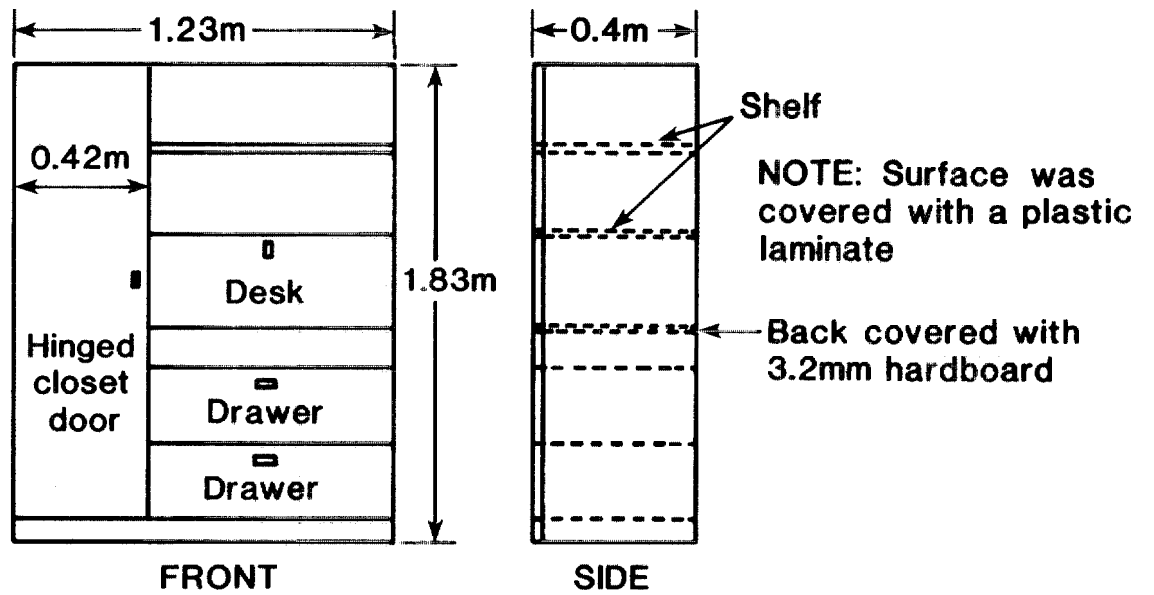
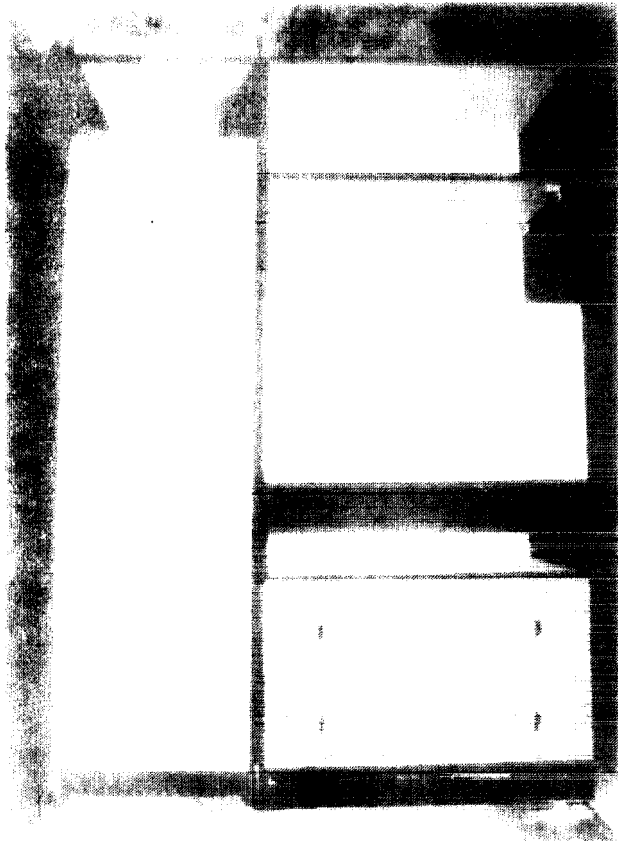

Figure 120. Photograph and sketch of .9.1 mm particleboard wardrobe, test 61

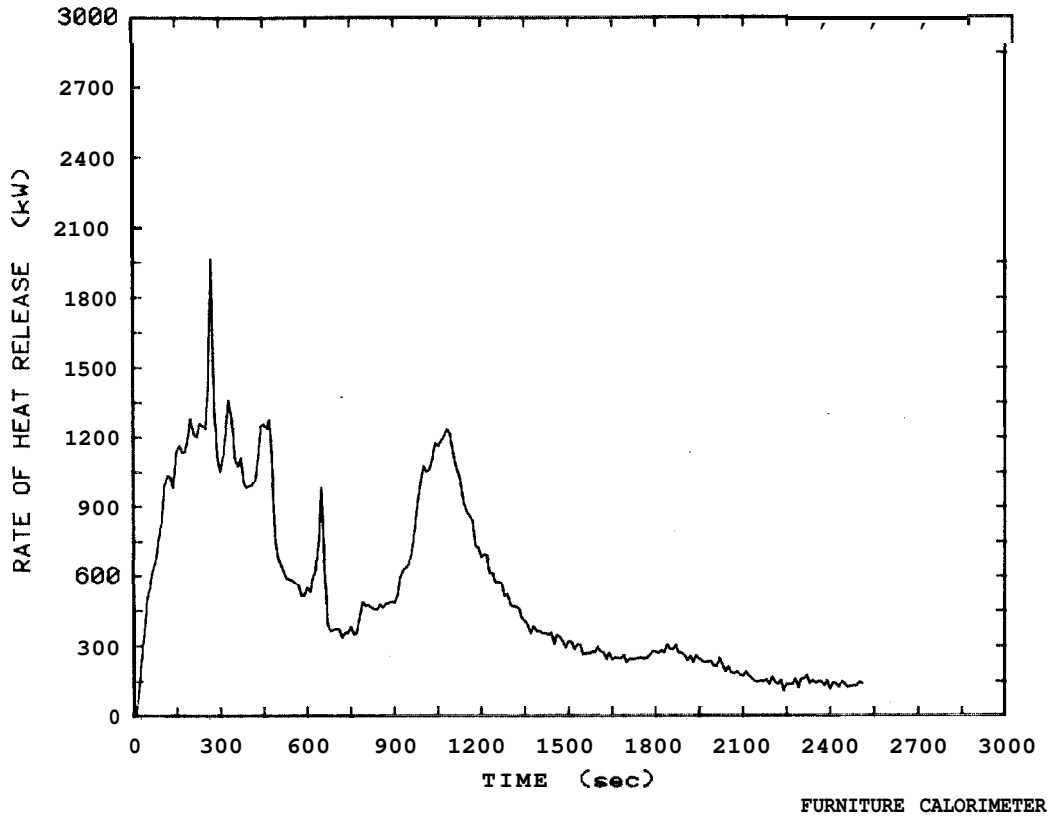

Figure 121. Rate of heat release plot for 19.1 mm particleboard wardrobe, Test 61

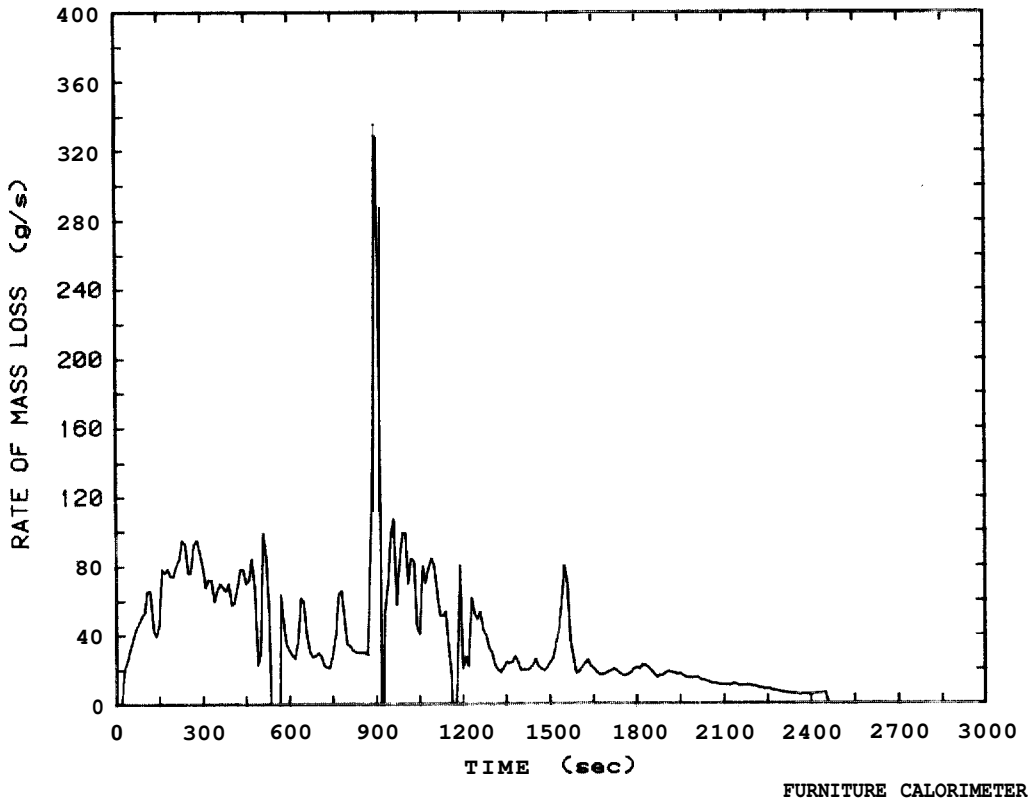

Figure 122. Rate of mass loss plot for 19.1 mm particleboard wardrobe, Test 61

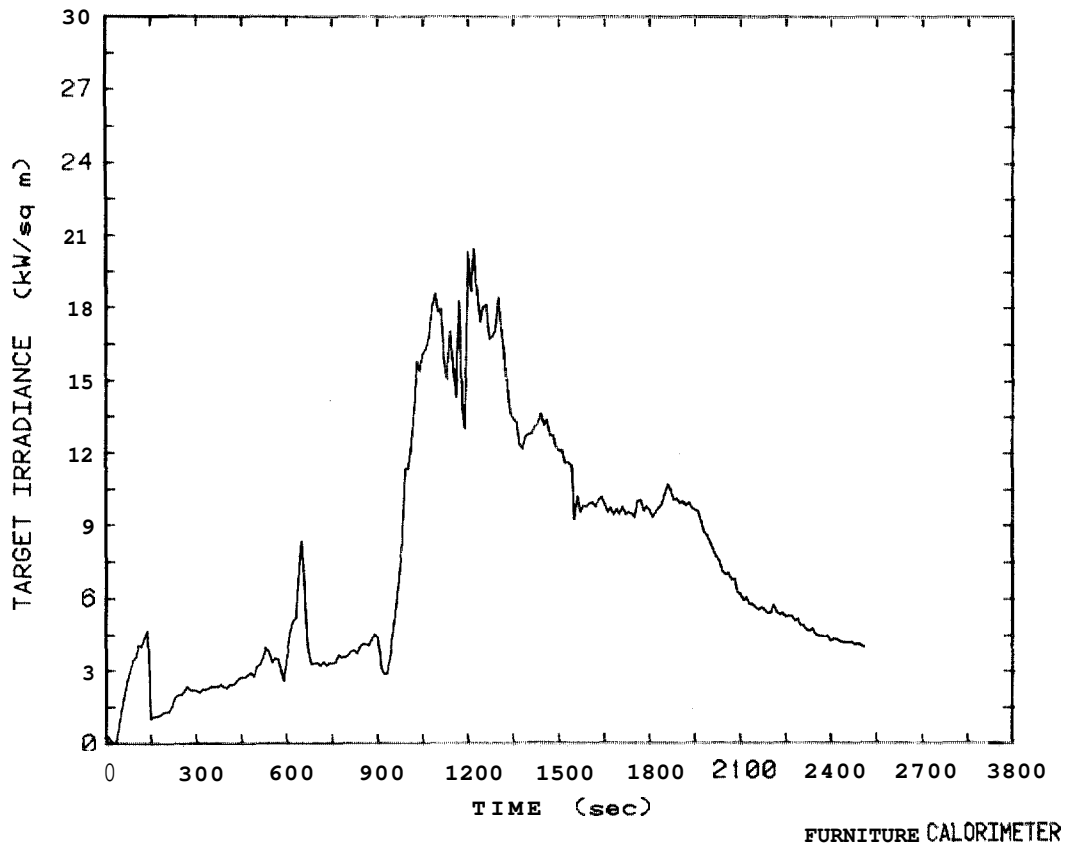

Figure 123: Target irradiance plot for 19.1 mm particleboard wardrobe, Test 61

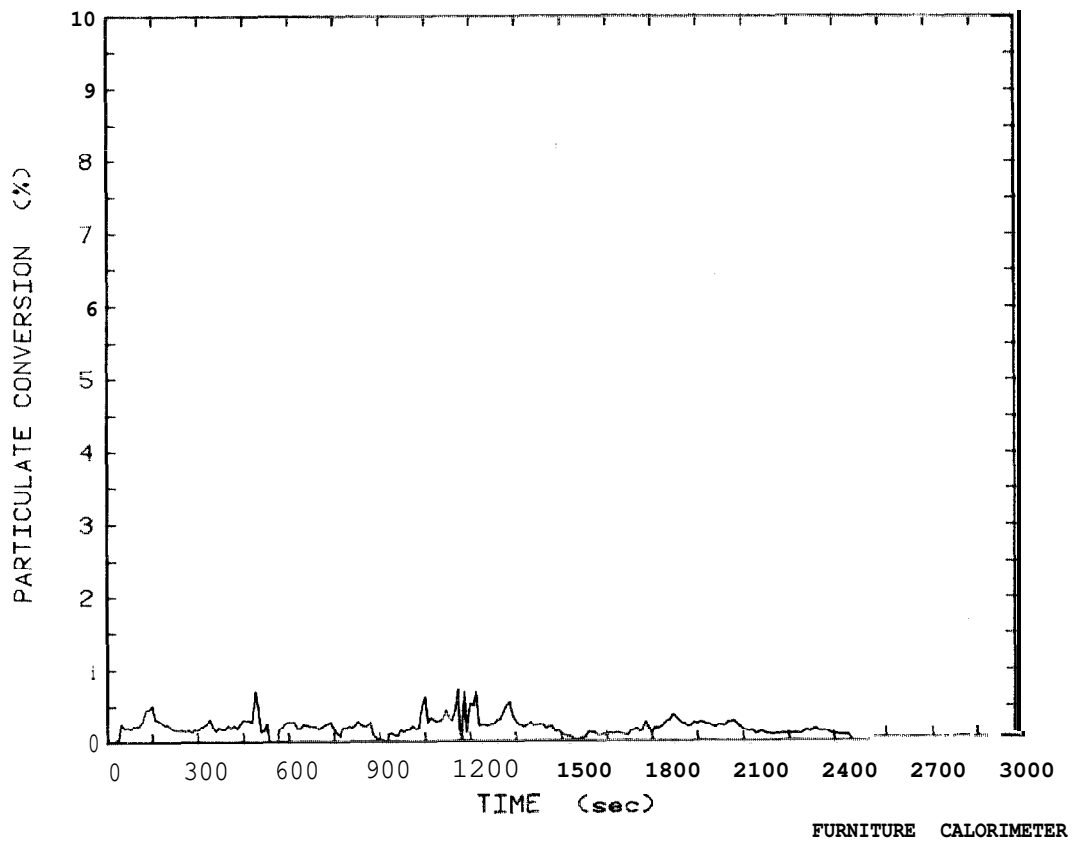

Figure 124: Smoke particulate conversion plot for 19.1 mm particleboard wardrobe, Test 61

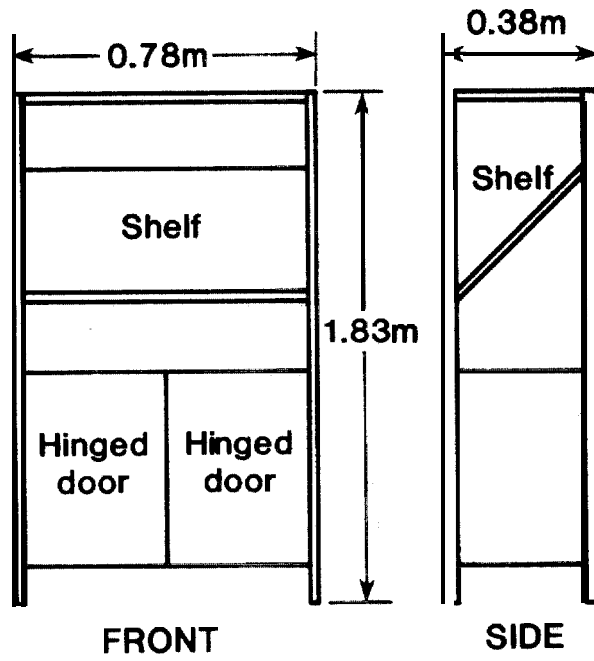
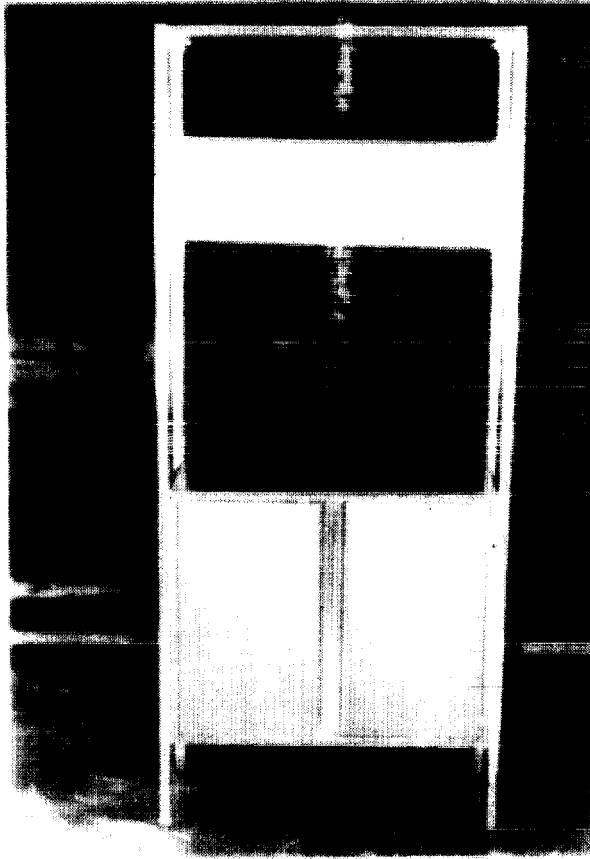

Figure 125. Photograph and sketch of 12.7 mm wood bookcase, test 62

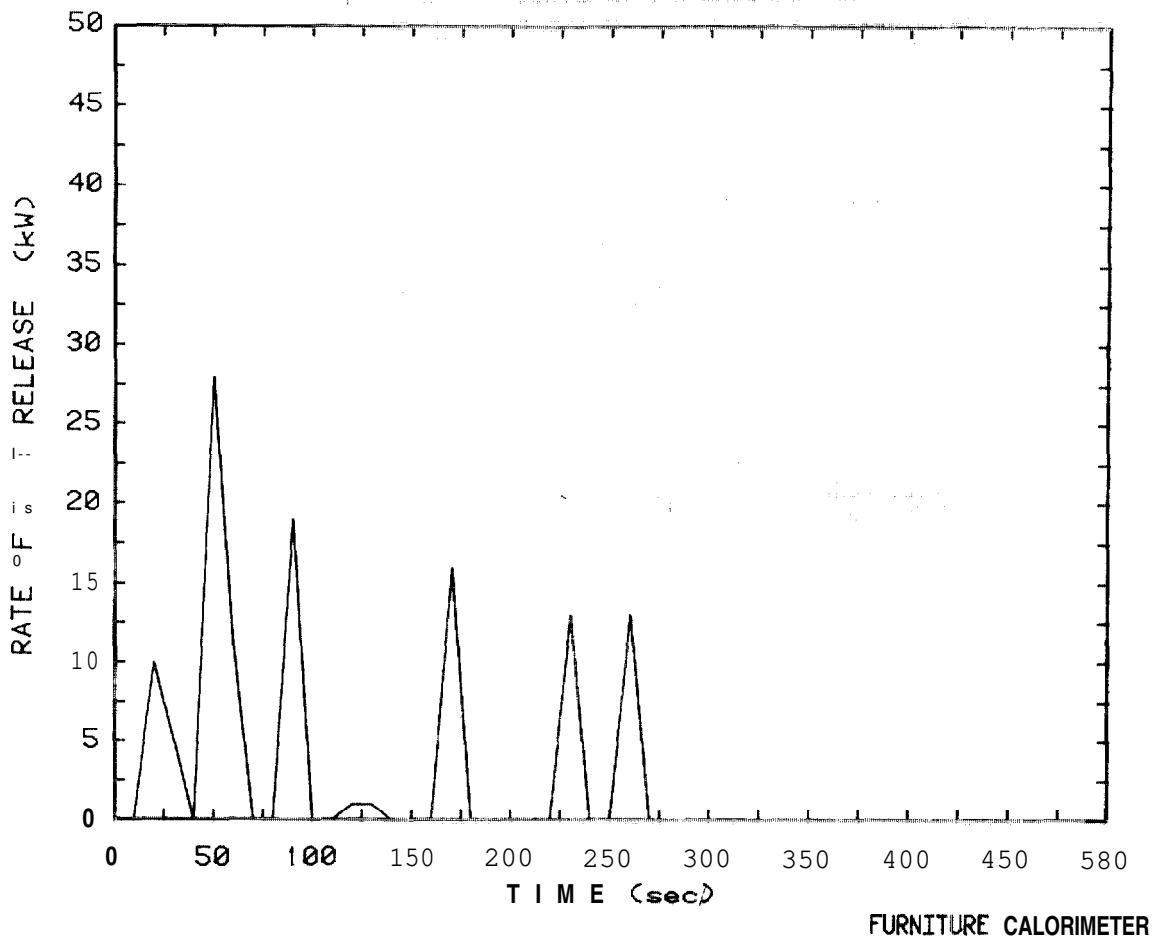

Figure 126. Rate of heat release plot for 12.7 mm wood bookcase, Test 62

8. SUMMARY

A heat release rate calorimeter based on the oxygen consumption technique developed at the National Bureau of Standards was used to measure the fire performance of 23 different types of furniture. This study was conducted to provide a catalog of performance information needed by the Department of Health and Human Services for developing guidelines for the selection of furnishings to be used in hospitals and nursing homes. Consequently, the furnishings evaluated in this study are typical of the types used in hospitals and nursing homes. Some of these **furnishings** may also be used in hotels or private residences. A total of 28 fire experiments were carried out which included five easy chairs, eight waiting room or patient chairs, three sofas, two mattresses, one bookcase, and nine wardrobe closets.

Data from these tests show **that** each of these furniture categories have furnishings that will promote the rapid growth of fire if they become ignited. Two of the five easy chairs tested and two of the three sofas tested released enough energy by themselves to promote flashover in an average size waiting room. Most of the metal frame chairs with minimum cushions or padding performed well. Results from the two bedding tests showed that the mattresses could not be easily ignited by a smoldering cigarette; however, the mattresses could be easily ignited by a relatively small flame on its bed sheet. The heat release rates from both bedding tests were also high enough to promote the rapid spread of flames in a **room**. Test results on wardrobe closets **showed** that this class of furnishing can provide a significant potential for the rapid development of a high intensity fire. Three of the four different wardrobe designs evaluated in this research project produced peak heat release

rates in excess of 1800 kW. The 12.7 mm plywood wardrobes consistently gave peak heat release rate values greater than 3000 kW, and the unfinished 3.2 mm plywood wardrobe exhibited the highest peak heat release rate measured in this study, more than 6000 kW. Painting the 3.2 mm plywood wardrobe inside and out with 2 coats of latex fire retardant paint only reduced the peak heat release rate by about one half. While this was a significant reduction, substantial increases in irradiance, smoke production, and carbon monoxide were experienced.

Only the metal wardrobe closets produced relatively low peak heat release rate values. It should be noted that the heat release rate from a metal wardrobe closet is primarily a function of the fabric load, contents spacing, and ventilation. Therefore, a large fire could also result from the burning contents of a metal wardrobe.

In conclusion, the information developed by this study on the fire performance of furnishings should provide designers and operators of health care facilities with information on the potential for fire growth resulting from the ignition of different types of furnishings. It also provides data which should be helpful in the development of fire performance standards for furniture. In addition, these test results provide a data base on furnishings for the study of fire growth in compartments and should be useful in mathematical modeling of fire development.

9. ACKNOWLEDGEMENTS

Appreciation is extended to the Washington, D.C., Veterans Administration Hospital, St. Elizabeth's Hospital, and the Consumer Product Safety Commission for the furniture used in this research project. Appreciation is expressed to Mr. William Bailey and Mr. Charles Velrtz of the Center for Fire Research for their assistance in the construction and operation of the furniture calorimeter. Special thanks is given to Mr. William Parker for his consultation on oxygen consumption theory and to Mr. Sanford Davis for providing assistance throughout the research project. This work was partially supported by the Department of Health and Human Services.

10. REFERENCES

- [1] Best, R., **Wincrest** Nursing Home and Cermak House Nursing Home Fires, Fire Journal, Vol. 70, No. 5 (September 1976).
- [2] Lathrop, J., Harrison, G. and Custer, R., In Osceola, A Matter of Contents, Fire Journal, Vol. 69, No. 3 (May 1975).
- [3] Damant, G.H., Williams, S.S. and Krasny, J.F., "Cigarette Ignition Behavior of Commercial **Upholstery** Cover Fabrics", Journal of Consumer Product Flammability, Vol. 9, No. 1, 31-46 (March **1982**).
- [4] Babrauskas, V., Full-Scale **Burning** Behavior of Upholstered Chairs, National Bureau of Standards (U.S.) Tech. Note 1103 (**1979**).
- [5] Fang, J. and Breese, J., Fire Development in Residential **Basement** Rooms, National Bureau of Standards (U.S.), NBSIR 80-2120 (1980).
- [6] Babrauskas, V., Lawson, J., Walton, W. and Twilley, W., Upholstered Furniture Burning Rates **Measured** with a Furniture Calorimeter, National Bureau of Standards (U.S.) NBSIR 82-2604 (1982).
- [7] O'Neill, J., Hayes, W. and Zile, R., Full-Scale Fire Tests with Automatic Sprinklers in a Patient Room, Phase II, National Bureau of Standards (U.S.), NBSIR **80-2097** (1980).
- [8] Chamberlain, D., Heat Release Rate Properties of Wood-Based Materials, National Bureau of Standards (**U.S.**), NBSIR 82-2597 (1983).
- [9] Sensenig, D., "An Oxygen Consumption Technique for Determining the Contribution of Interior Wall Finishes to Room Fires", National Bureau of Standards (U.S.) Tech. Note 1128 (1980).
- [10] Parker, W., Calculations of the Heat Release Rate by Oxygen Consumption **for** Various Applications, National Bureau of Standards (U.S.), NBSLR 81-2427-1 (1982).
- [11] Huggett, C., "Estimation of Rate of Heat Release by Means of Oxygen Consumption Measurements", Fire and Materials, Vol. 4, No. 2 (1980).
- [12] Bukowski, R., Smoke Measurements in Large and Small-Scale Fire Testing, Fire Technology, 15, 173-9, 271-281 (1979).
- [13] Babrauskas, V., Will the Second Item Ignite?, **National** Bureau of Standards (U.S.), NBSIR 81-2271 (1981).

U.S. DEPT. OF COMM. BIBLIOGRAPHIC DATA SHEET (See instructions)	1. PUBLICATION OR REPORT NO. NBSIR 83-2787	2. Performing Organ. Report No.	3. Publication Date January 1984
4. TITLE AND SUBTITLE Fire Performance of Furnishings as Measured in the NBS Furniture Calorimeter. Part I			
5. AUTHOR(S) J. Randall Lawson, W. D. Walton, William H. Twilley			
6. PERFORMING ORGANIZATION (If joint or other than NBS, see instructions) NATIONAL BUREAU OF STANDARDS DEPARTMENT OF COMMERCE WASHINGTON, D.C. 20234		7. Contract/Grant No. 8. Type of Report & Period Covered	
9. SPONSORING ORGANIZATION NAME AND COMPLETE ADDRESS (Street, City, State, ZIP)			
10. SUPPLEMENTARY NOTES <input type="checkbox"/> Document describes a computer program; SF-185, FIPS Software Summary, is attached.			
11. ABSTRACT (A 200-word or less factual summary of most significant information. If document includes a significant bibliography or literature survey, mention it here)			
<p>A heat release rate calorimeter developed at the National Bureau of Standards was used to measure the fire performance of a wide range of furnishings. The heat release rates measured in the calorimeter are determined through the use of oxygen consumption techniques. Data are presented on the free burning characteristics of 28 tests involving 23 different types of furnishings. The furnishings evaluated are classed into the following groups: easy chairs, sofas, waiting room and patient chairs, wardrobe closets, bookcase and bedding.</p> <p>The information presented in this report will provide a basis for selecting types of furniture to be used in health care facilities, hospitals and other living facilities. The test results also provide information needed by other areas of fire research, such as the study of fire growth in compartments and mathematical modeling of fire development.</p> <p>In addition to heat release rates, data are given on the rates of mass loss, thermal radiation and smoke production from the burning furniture specimens.</p>			
12. KEY WORDS (Six to twelve entries; alphabetical order; capitalize only proper names; and separate key words by semicolons)			
Furniture; calorimeter; heat release rate; mass loss rate; radiant energy; smoke.			
13. AVAILABILITY <input checked="" type="checkbox"/> Unlimited <input type="checkbox"/> For Official Distribution. Do Not Release to NTIS <input type="checkbox"/> Order From Superintendent of Documents, U.S. Government Printing Office, Washington, D.C. 20402. <input checked="" type="checkbox"/> Order From National Technical Information Service (NTIS), Springfield, VA. 22161		14. NO. OF PRINTED PAGES 133 15. Price \$14.50	