

Iowa State University

From the Selected Works of Steven P. Bradbury

1987

Fish Acute Toxicity Syndromes and Their Use in the QSAR Approach to Hazard Assessment

Steven P. Bradbury

James M. McKim

Gerald J. Niemi



Available at: https://works.bepress.com/steven_bradbury/38/

Fish Acute Toxicity Syndromes and Their Use in the QSAR Approach to Hazard Assessment

by James M. McKim,* Steven P. Bradbury,* and Gerald J. Niemi†

Implementation of the Toxic Substances Control Act of 1977 creates the need to reliably establish testing priorities because laboratory resources are limited and the number of industrial chemicals requiring evaluation is overwhelming. The use of quantitative structure activity relationship (QSAR) models as rapid and predictive screening tools to select more potentially hazardous chemicals for in-depth laboratory evaluation has been proposed. Further implementation and refinement of quantitative structure-toxicity relationships in aquatic toxicology and hazard assessment requires the development of a "mode-of-action" database. With such a database, a qualitative structure-activity relationship can be formulated to assign the proper mode of action, and respective QSAR, to a given chemical structure. In this review, the development of fish acute toxicity syndromes (FATS), which are toxic-response sets based on various behavioral and physiological-biochemical measurements, and their projected use in the mode-of-action database are outlined. Using behavioral parameters monitored in the fathead minnow during acute toxicity testing, FATS associated with acetylcholinesterase (AChE) inhibitors and narcotics could be reliably predicted. However, compounds classified as oxidative phosphorylation uncouplers or stimulants could not be resolved. Refinement of this approach by using respiratory-cardiovascular responses in the rainbow trout, enabled FATS associated with AChE inhibitors, convulsants, narcotics, respiratory blockers, respiratory membrane irritants, and uncouplers to be correctly predicted.

Introduction

The useful application of physiological and biochemical diagnostic tests in aquatic toxicology falls into three general areas (1). First, these tests can serve as sensitive, rapid, and sublethal indicators of the potential impact of a toxic chemical on the survival, reproduction, and/or growth of an aquatic species. Second, the sensitive nature of biological systems for indicating the presence and quantity of selected chemicals can be used through "true bioassays." Third, these tests can be important in developing an understanding of the mechanism of action of toxic chemicals in aquatic species.

The use of sensitive diagnostic tests to efficiently predict environmental impacts on aquatic animals cannot be denied, and a long list of physiological and biochemical endpoints have been developed for fish (1,2). However, this approach has not been successful for hazard assessment primarily because there is a lack of correspondence between the physiological-biochemical endpoints and whole-animal responses (3-5). Furthermore,

the use of physiological diagnostic tests to detect xenobiotics has provided limited utility in aquatic toxicology, as reviewed by Klaverkamp (1) on the cardiodepressor activity of phthalic acid esters (6-8).

The third category of physiological-biochemical investigations, designed to elucidate the mechanistic aspects of aquatic toxicology, has received more attention in the last decade. Specifically, the studies of Skidmore (9) and Hughes and Adeney (10) on heavy metals, Bass and Heath (11) on chlorine, Smart (12) on ammonia, Lockowitz et al. (13) on MS222, quinaldine and urethane, Duangsawasdi and Klaverkamp (14) on organophosphate insecticides, Jones (15) and Hunn (16) on cyanide, and Dannell (17) and Perry and Conway (18) on rotenone, have provided the initial data sets on the mechanistic attributes of selected environmental chemicals that are related to the specific endpoint of acute lethality. More recently, an effort to develop a testing protocol using behavioral (19) and physiological-biochemical (20-22) variables to group chemicals by acute-lethal mode of action was completed. These mechanistic studies are linked to whole-animal responses and provide an important first step in the use and application of behavioral and physiological-biochemical measurements in aquatic toxicology.

*U.S. Environmental Protection Agency, Environmental Research Laboratory-Duluth, 6201 Congdon Boulevard, Duluth, MN 55804.

†Natural Resources Research Institute, University of Minnesota-Duluth, Duluth, MN 55812.

This paper will review the more recent development of fish acute toxicity syndromes (FATS) and their use in predictive toxicology and hazard assessment.

Predictive Toxicology and Quantitative Structure-Activity Relationships (QSARs) for Industrial Chemicals

In the United States, the current inventory of industrial chemicals is in excess of 50,000 compounds and additional chemicals and/or new uses of existing materials are increasing at a rate of about 1000/year (23). Under the Toxic Substances Control Act (TSCA) of 1977, the United States Environmental Protection Agency is charged with the responsibility of assessing the hazards of new chemicals and new uses of existing chemicals to human health and the environment prior to their use. If a substance presents an unreasonable risk to human health or the environment, it may be banned or restricted in use. The implementation of TSCA creates the need to reliably establish testing priorities because laboratory resources are limited and the number of potential compounds for study is overwhelming. The implementation of a QSAR approach was proposed as a rapid and predictive screening tool to identify potentially hazardous chemicals for in-depth evaluation (24,25).

In the fields of pharmacology and toxicology, structure-activity relationships (SARs) are mathematical relationships between measurable biological activity (e.g., toxicity or therapeutic response) and structural attributes of a chemical such as some physicochemical properties (e.g., 1-octanol/water partition coefficient, electronegativity, steric hindrance, Taft's constant, etc.). QSARs must be developed for each mode of action involved with the activity of interest (24), thus for structure-toxicity relationships, separate QSARs must be formulated for those chemicals associated with a common toxic mode of action. In the field of aquatic toxicology and hazard assessment, QSAR predictions must reliably distinguish between chemicals requiring thorough testing and those that do not (24).

Within the context of this need, Veith et al. (25) have developed a QSAR model to predict the acute lethality of a major proportion of industrial organic chemicals to fish. Lethality testing thus far has indicated that a large proportion of industrial chemicals lack identifiable structural characteristics that impart biological activity through specific mechanisms. Instead, these compounds are acutely toxic to aquatic organisms by a nonspecific mode of action termed narcosis (25). Compounds associated with a narcotic effect in mammals, fish, and aquatic invertebrates include inert gases, aliphatic and aromatic hydrocarbons, chlorinated hydrocarbons, alcohols, ethers, ketones, aldehydes, weak acids and bases, and some aliphatic nitro compounds (24-30). Based on the research of Ferguson (31) and Mullins (32), Veith et al. (25) proposed that acute nar-

cosis in fish should be directly proportional to the 1-octanol/water partition coefficient ($\log P$). Using fathead minnow 96-hr LC_{50} data, it was established that the lethality of 10 alkyl alcohols, previously demonstrated to exhibit narcosis in mammals, was related to $\log P$ (25) (Fig. 1). Subsequent testing with a total of 65 compounds including ketones, ethers, alkyl halides, and substituted benzenes, further verified the QSAR (25) given in Eq. (1) (Fig. 2):

$$\log LC_{50} = -0.94 \log P + 0.94 \log(0.000068 \log P + 1) - 1.25 \quad (1)$$

$$(\gamma^2 = 0.9936)$$

Similar relationships with the guppy (33) and *Daphnia magna* (34) have been reported as well. Also presented in Figures 1 and 2 is the relationship between water solubility and $\log P$, which delineates the "aquatic toxicity space" as that region below water solubility; i.e., acute toxicity cannot be measured under equilibrium conditions at concentrations greater than aqueous solubility (25).

The narcosis QSAR is currently considered a predictor of baseline toxicity. Although the majority of industrial chemicals can be treated as narcotics, the toxicity of compounds associated with a specific mode of action (e.g., acetylcholinesterase (AChE) inhibition, uncoupling of oxidative phosphorylation, etc.) would be underestimated with the narcosis QSAR; i.e., the lethality of these more specific chemicals in the aquatic toxicity space (Figs. 1 and 2) lies below that predicted by the current model. Additional molecular descriptors and chemical properties will be required in the formation of subsequent QSARs. However, to predict acute

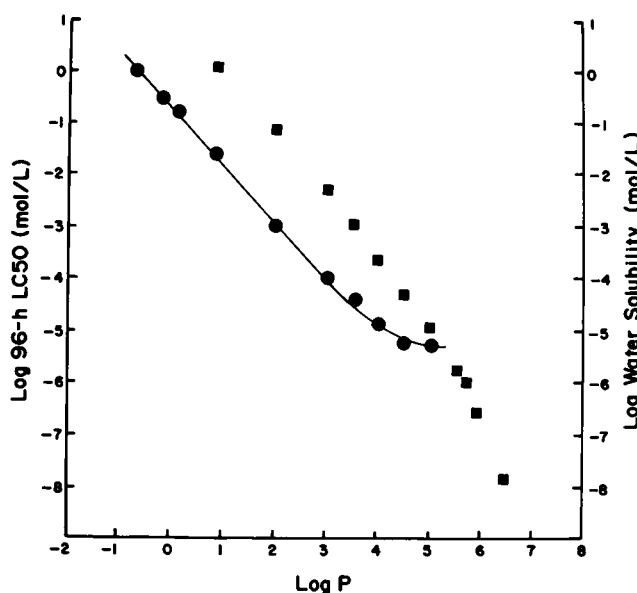

FIGURE 1. Bilinear relationship between water solubility (squares) or 96-hr LC_{50} concentrations (circles) for fathead minnows with 1-octanol/water partition coefficient ($\log P$) for some aliphatic alcohols. From Veith et al. (25).

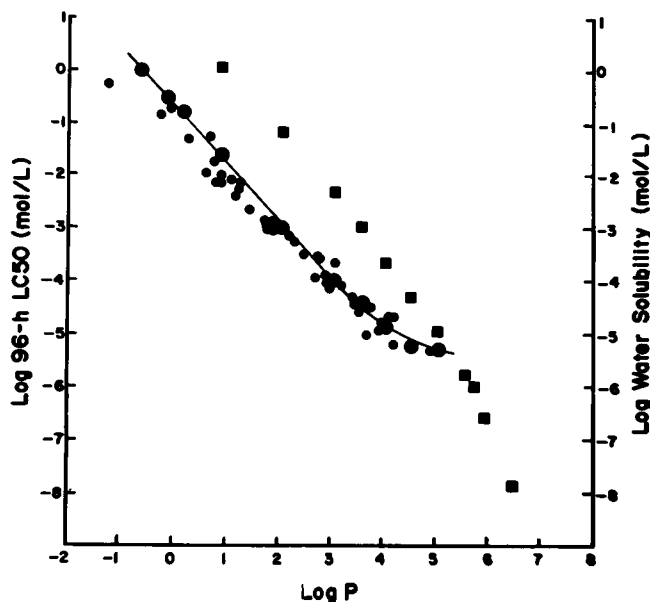

FIGURE 2. Relationship between 96-hr LC_{50} concentrations (circles) for fathead minnows of some narcotic chemicals and $\log P$ superimposed on a bilinear alcohol model. From Vieth et al. (25).

toxicity reliably from any given set of structural parameters, the QSAR associated with the proper mode of action must be invoked. Further implementation and refinement of quantitative structure-toxicity relationships in aquatic toxicology and hazard assessment will require the development of qualitative SARs that assign the proper mode of action, and respective QSAR, to a given chemical structure. This effort necessitates creating a "toxic mode-of-action" database as well as the definition and quantitation of the appropriate chemical properties. The current effort in developing the components for this qualitative model is centered on characterizing the mode-of-action portion of this database.

Developing the database does not involve a description of events at the molecular level, but rather relies on an understanding of the causal relation of a specific toxicant through direct and indirect evaluation of *in vivo* toxic responses (35). The assumption is that chemicals of a common mode of action will elicit a specific and distinct set of toxic responses. To clarify the distinction between these measured *in vivo* responses and the data associated with mechanistic investigations, the measured response sets are called fish acute toxicity syndromes (FATS) (20).

The general protocol to build and use the FATS database is outlined in Figure 3. *In vivo* toxic responses associated with behavior, biochemistry, the respiratory-cardiovascular system, etc., are measured during aqueous exposure to chemicals with known modes of action. The large number of responses monitored, and their interdependence, results in a complex matrix of quantitative and qualitative data. Through the use of multivariate statistical analyses such as discriminant

function analysis (DFA) (36), the complex data sets can be simplified and the best response variables for predicting a specific FATS can be determined. Through this experimental approach and statistical evaluation, investigators are successfully resolving a number of distinct FATS that correspond to specific modes of action (see subsequent section). Theoretically, once the relationship between chemical structures and mode of action can be identified, the appropriate molecular descriptors, chemical properties, and corresponding acute toxicity databases can be analyzed to build the respective quantitative structure-toxicity models (lower part of Fig. 3). One of the major limiting factors at the current time for the development of these relationships is the lack of a systematic chemical database on mode of toxic action.

Fish Acute Toxicity Syndromes (FATS)

As described in the previous section, QSAR models must be developed for those chemicals with a common mode of action. To optimize the QSAR approach, a systematic effort was initiated to define and predict the lethal modes of action for industrial chemicals through whole-animal behavioral (19) and biochemical and respiratory-cardiovascular physiological studies (20-22). The response sets generated from specific tests selected from these major disciplines were described as FATS (20). Each FATS is a characteristic set of whole-animal responses (clinical signs). We propose that chemicals with a common mode of action will elicit a set of responses associated with a specific FATS, thereby providing categories into which whole-fish responses to acute toxicity can be grouped. Initially to test this assumption, eight chemicals from four well-described modes of action (respiratory uncouplers, narcotics, AChE inhibitors, and membrane irritants) were selected for evaluation (Table 1) (19-21).

Behavioral Approach

Behavioral monitoring has shown considerable promise as a screening procedure to identify the mode of action of various industrial chemicals. One advantage of this approach was that the behavioral observations could be made on fish during routine acute toxicity testing (37), another necessary ingredient in the development of QSARs. Drummond et al. (19) developed a fish behavior checklist that established a standardized set of behavioral/morphological signs of poisoning for 30-day-old fathead minnows. This checklist is specifically designed to separate individual chemicals into groups, based on their general toxic mode of action. During acute toxicity testing the checklist was used by the investigators at 8, 24, 48, 72, and 96 hr to record mutually exclusive events as opposed to using a graded or intensity of response scale. Behavioral and morphological aberrations were recorded whenever 10% or more of the fish in a given exposure tank appeared stressed. The checklist was accompanied by guidelines and defi-

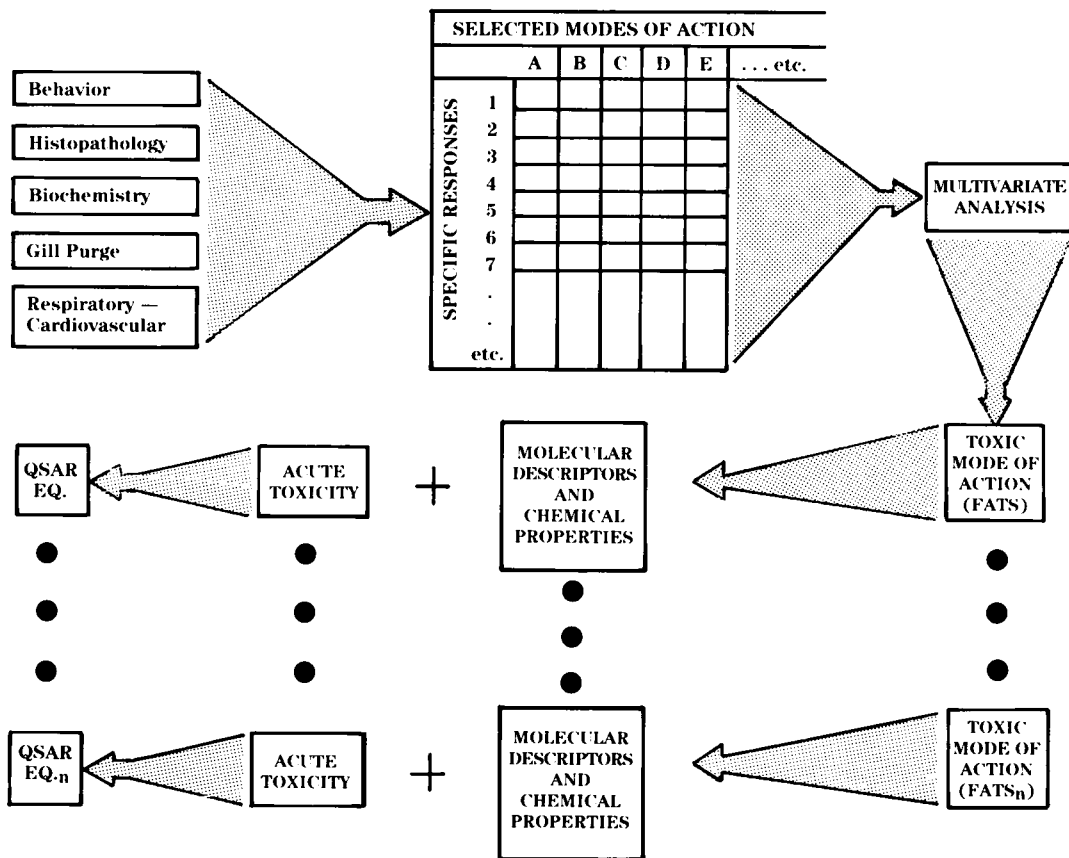

FIGURE 3. Flow chart relating fish acute toxicity syndrome (FATS) research to the generation of QSAR equations for predicting the acute toxicity of organic chemicals to fish.

Table 1. Chemicals with known modes of action selected from the literature.

Mode of action	Chemical
Uncouplers	2,4-Dinitrophenol Pentachlorophenol
AChE inhibitors	Malathion Carbaryl
Anesthetics-narcotics	1-Octanol MS222
Membrane irritants	Acrolein Benzaldehyde

nitions of terminology and was divided into major categories covering equilibrium, locomotor activities, fish dispersion, body movements, coloration, pathology, and unique behaviors not previously defined. Percentage occurrence of each behavior was determined for individual chemicals. Percentages were calculated on the basis of a matrix having a maximum of 25 cells (five concentrations \times five time intervals). Only cells with live fish were used in the analysis. The data was clustered by hand, before conducting DFA, to graphically depict patterns of response. The chemicals tested in these behavior studies included those in Table 1 plus eight more in each of the four mode-of-action groups (Table 2). Hence,

ten different chemicals represented each of the four mode-of-action groups. Characteristic response patterns for each of these four mode-of-action groups are outlined in Table 3, with the major discriminating responses summarized in the last row of the table.

DFA revealed that behavioral data could be used to identify and separate chemicals into toxic mode-of-action groups (Fig. 4). Narcotic and AChE inhibitory chemicals fell into clearly defined groups which were distinct from those classed as uncouplers and stimulants. However, the response of the latter two groups were very similar and overlapped considerably as shown in Figure 4. Therefore, with the behavioral response sets described in Table 3, three distinct behavioral FATS could be delineated for use in QSAR development. Evaluation of other physiological variables will be required to validate the chemicals within these FATS. In addition, chemicals predicted in the uncoupler-stimulant group will likely need to be further separated through physiological or biochemical FATS.

Physiological-Biochemical Approach

The use of physiological-biochemical responses to rapidly predict effect-no effect environmental concentrations of chemicals has very limited value at this time

Table 2. List of 40 chemicals tested and the mode-of-action group into which they were placed according to behavioral responses.^a

Narcotics	Uncouplers	Stimulantlike	AChE inhibitors
Alcohols	Aldehydes	Carboxylic acids	Ethers
2-Ethyl-1-hexanol	Isovaleraldehyde	Salicylic acid	<i>p</i> -Fluorophenyl ether
1-Octanol	Acrolein		
Esters	Esters	Esters	Aldehydes
Phenyl-4-aminosalicylate	Hydroxypropyl acrylate	Cyclohexyl acrylate	Benzaldehyde
<i>m</i> -Bromobenzamide	Isobutyl acrylate		
Dimethylaminoterephthalate	Methyl acetate		
<i>p</i> -(<i>tert</i> -butyl) benzamide	Hydroxethylmethacrylate		
MS222			
Amines	Amines	Amines	Esters
Tripropargylamine	3,4-Dichloroaniline	2-Chloroaniline	2-Hydroxyethyl acrylate
4-Hexyloxyaniline		<i>N,N</i> -Dimethylbenzylamine	
Heterocyclic nitrogen compounds	Phenols	Benzenes	Heterocyclic nitrogen compounds
4-Bromophenyl 3-pyridyl ketone	Pentachlorophenol	1,4-Dichlorobenzene ^b	4-Benzoylpyridine
	2,4-Dinitrophenol	<i>tert</i> -Butylstyrene ^c	2-Cyanopyridine
			Pentachloropyridine
			6-Chloro-2-picoline
	Heterocyclic nitrogen compounds	Phenols	Phosphorus compounds
	2,6-Pyridicarboxylic acid	Hydroquinone methyl ester ^d	Triphenyl-1-phosphate
		4,5-Dichlorocatechol	Malathion
		Heterocyclic nitrogen compounds	Carbamates
		2-Methylimidazole	Carbaryl
		<i>N</i> -Methylpiperazine	

^a Data from Drummond et al. (19).

^b Convulsions and tetany evident; possible neurotoxicant.

^c Tetany evident; classification uncertain.

^d Convulsions evident; possible neurotoxicant.

(see Introduction). However, we feel these responses will be useful in understanding the mechanistic aspects of aquatic toxicology, especially as needed for FATS identification and subsequent QSAR development.

McKim et al. (20,21) have successfully used an *in vivo*, transected fish model to monitor respiratory-cardiovascular responses of 600 to 900 g rainbow trout exposed to acutely lethal aqueous concentrations of selected industrial chemicals (Fig. 5). The model allows for the simultaneous measurement of 26 respiratory-cardiovascular, hematological, and urinary variables, plus any behavioral responses elicited by the transected trout (i.e., nystagmus, pretechia, convulsions, etc.). Prior to each chemical exposure (Table 1) two to three sets of respiratory-cardiovascular measurements and one set of blood measurements were made on each fish. These measurements provided predose values for each fish from which an individual percentage change could be calculated for each variable during exposure. In this way each fish served as its own control. To eliminate initial stress effects and final-stage death effects from the clinical signs elicited by the specific chemicals, a mean percentage change for each respiratory-cardiovascular measurement for each fish was determined from all values measured between 25 and 75% survival time.

The most impressive diagnostic response representative of the respiratory uncoupler syndrome was a rapid and continuous increase in ventilation volume and oxygen consumption over the entire survival period. This

corresponded to a continuously rising metabolic rate, which was not impacted to any degree by increased activity since the exposed animals were immobilized. Interestingly, the increase in ventilation volume and oxygen consumption did not include a change in either oxygen uptake efficiency or ventilation rate (Fig. 6). The trout were therefore increasing the water flow across their gills by increasing the ventilatory stroke volume, while at the same time maintaining a constant percentage removal of oxygen at the lamellar surface. The elevated oxygen consumption was reflected by an initial increase in total arterial oxygen content that lasted for almost half of the survival period and then fell slowly, presumably as the tissues used more oxygen in an effort to generate ATP (Fig. 7). Trout are known to possess a system(s) that enables them to increase blood flow to the lamellar surface [nonrespiratory shunt model (38,39), and the lamellar recruitment model (40-43)]. In addition, trout can increase cardiac output and pulse pressure, which increases the perfusion rate of the lamellae and provides better oxygen extraction at the gills (44). Respiratory responses indicating gross gill damage, as described by Skidmore (9), were not observed. This finding was further supported by the work of Morrison (45), who found no gill damage in rainbow trout exposed to acutely toxic amounts of pentachlorophenol. Hematocrit, hemoglobin, arterial pH, and total arterial carbon dioxide remained unchanged (Fig. 7), while $[K^+]_p$, $[Ca^{2+}]_p$, and $[Mg^{2+}]_p$ increased in these trout on exposure to both respiratory uncouplers.

Table 3. Fish behavioral and morphological response groups indicative of mode of action.^a

Behavioral/morphological event	Most typical pattern of response			
	Narcosis	Uncoupler	AChE inhibitor	Stimulantlike
Loss of equilibrium	Fish lay on sides or suspended vertically	Loss of equilibrium near death	Loss of equilibrium	Loss of equilibrium
Spontaneous swimming activity	Hypoactive	Hyperactive	Tend to be hypoactive	Hyper- to super-hyperactive; some agonistic behavior
Corkscrew spiral swimming	Minor corkscrew swimming in attempt to maintain equilibria	May exhibit spiral swimming	High incidence-corkscrew and spiral swimming	Minor incidence of corkscrew swimming
Startle response	Greatly reduced or non-existent.	Overreactive	Usually overreactive	May be over or underreactive to outside stimuli—depends on level of stress ^b
Ventilatory pattern	May show rapid and shallow increase	Increase in rate and amplitude	Increase in rate and amplitude	Increase in rate and amplitude
Body movements	No gross change	No gross change	Some tetany and convulsions	Some tail vibration
Body coloration	Very dark (black)	May be dark (brown)	Dark (brown or black)	May be dark (brown or black)
Hemorrhage	Not present	Usually not present	Present	May be present on snout
Deformities	May exhibit mild edema	May exhibit mild edema	High incidence of scoliosis-lordosis	May exhibit severe edema
Mortality pattern	Most die in 24 hr	Most die 24–72 hr	Most die 24–96 hr	Die throughout the test
Chief characteristics	Hypoactive, under-reactive to outside stimuli, very dark (blackish) in color, respiration rapid and shallow	Hyperactive and overreactive. Most die without exhibiting numerous signs of stress	Generally hypoactive; overreactive to stimuli; high incidence of abnormal swimming; deformities; numerous signs of stress	Extremely hyperactive, 0–96 hr; agonistic or other unusual behaviors; death throughout exposure

^aData of Drummond et al. (19).

^bHighly stressed (hyperactive) fish tend not to respond to outside stimuli.

The overall response of trout to narcosis syndrome chemicals, MS222 and 1-octanol, was a dramatic slowing of all respiratory-cardiovascular functions (Fig. 6), which rapidly traversed the classic series of anesthesia stages (46) that include loss of reaction to external stimuli, loss of equilibrium (not apparent in transected fish), decline in respiratory rate, and medullary collapse. While ventilation volume and oxygen consumption decreased, oxygen uptake efficiency increased as water flow over the gills slowed and the blood-to-water perfusion ratio increased. Ventilation rate declined initially and then increased slowly until death. This increase in ventilation rate was simply hyperventilation as little or no water was being pumped across the gills. As respiration declined, water flow over the gills was reduced and total arterial oxygen decreased as did arterial pH. In response to hypoxia, hematocrit increased substantially, while hemoglobin increased slightly (Fig. 7). During anesthesia, this increase in hematocrit (brought on by red blood cell swelling) (47–50), is a well-documented response to hypoxia. Increased hemoglobin was probably caused by the release of stored red blood cells (18,51,52). The rapid drop in heart rate (reflex bradycardia) was likely related to the increase in vagal tone caused by hypoxia (13). The plasma ions measured in trout exposed to these narcotics showed no indication

of hemoconcentration, as described earlier by Houston et al. (51).

The most striking respiratory-cardiovascular responses noted for the AChE inhibitor syndrome chemicals, malathion and carbaryl, were immediate decreases in oxygen uptake efficiency and heart rate (Fig. 6) (21). Ventilation volume seemingly increased to compensate for the lower oxygen uptake efficiency, but not enough to increase total oxygen consumption. Klaverkamp et al. (1) and Duangsawadi and Klaverkamp (53) also observed a greatly reduced heart rate along with an increased ventilation rate and buccal amplitude for two additional organophosphate (OP) insecticides, acephate and fenitrothion.

The respiratory-cardiovascular responses described for OP and carbamate insecticides in fish can perhaps be explained by the action of acetylcholine. The uptake of oxygen by the gills of fish is in large part determined by their respiratory surface area, which can be increased by epinephrine (vasodilation) or decreased by acetylcholine (vasoconstriction) (54–59). Inhibition of AChE in the gills would likely result in continuous stimulation of neural-muscular junctions and could cause sphincters at the base of the efferent filamental arteries to constrict (60,61) and reduce blood flow through certain secondary lamellae. This reduction of respiratory

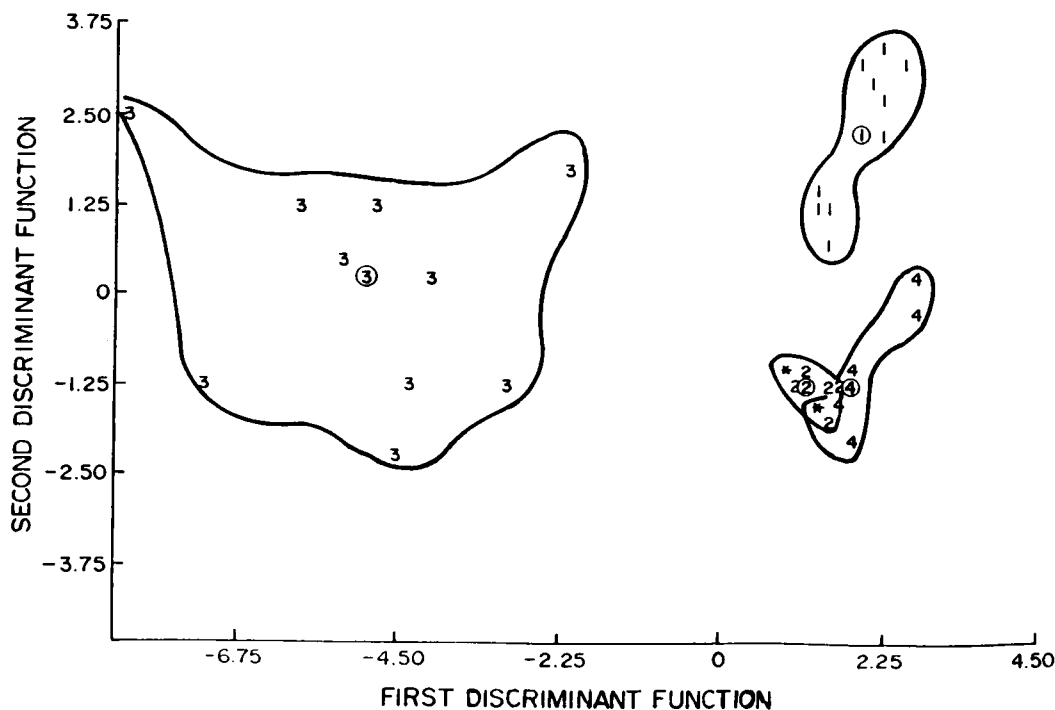

FIGURE 4. Discriminant function analysis plot of 40 compounds clustered according to chemicals associated with known modes of action: (1) narcotics; (2) uncouplers; (3) AChE inhibitors; (4) stimulants. Circled numbers show group mean. Asterisk denotes overlap of different groups. Modified from Drummond et al. (19).

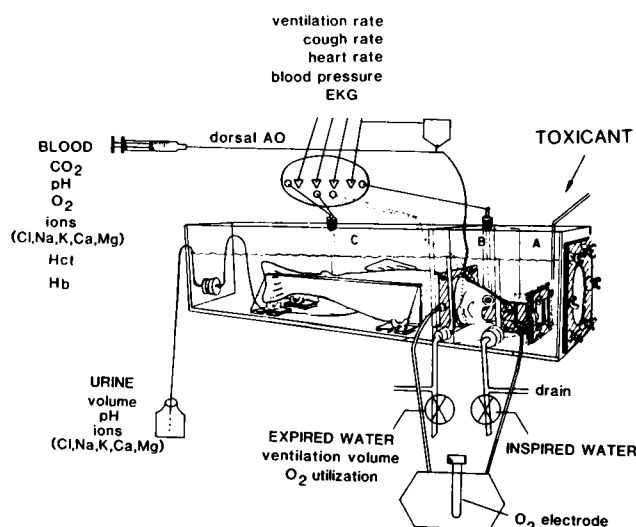

FIGURE 5. Experimental apparatus for monitoring fish physiological responses to toxic chemicals.

surface area would decrease oxygen uptake efficiency as observed in the present study. Reduction in heart rate in malathion and carbaryl intoxicated fish was likely due to excessive inhibition of the heart by the vagus nerve (mediated by cholinergic synapses) (62–65).

Carbaryl respiratory-cardiovascular responses were similar to those caused by malathion exposure except that during carbaryl intoxication an increase in hematocrit and hemoglobin and a more extensive drop in

arterial pH and total arterial carbon dioxide were observed. These differences seemed to suggest that secondary mechanisms resulting in hypoxia or hyperlactemia, in addition to AChE inhibition, were associated with carbaryl intoxication. Sastry and Siddiqui (66) suggested that anaerobic metabolism was favored and aerobic oxidation of pyruvate was impaired in fish exposed to carbaryl. Finally, $[Ca^{2+}]_p$ and $[Mg^{2+}]_p$ increased significantly when trout were exposed to the AChE inhibitors.

Histological damage to the gills by malathion and carbaryl was observed in *Tilapia* at acutely lethal concentrations (67–68). However, the respiratory-cardiovascular responses observed here (high total arterial oxygen, normal oxygen consumption) during 80% of the survival period (Fig. 7) were not indicative of extensive gill damage or reduced diffusion of gases as described for gill irritants (10,69).

The overall respiratory-cardiovascular responses representative of the respiratory irritant syndrome chemicals, acrolein and benzaldehyde, indicated a direct toxic effect on gill structure (21). Accompanying an initial rapid increase in cough rate was an initially moderate-to-low increase in ventilation volume and total oxygen consumption. However, at 50 to 60% survival time a consistent drop in ventilation volume and total oxygen consumption was observed (Fig. 6). Ventilation rate, oxygen uptake efficiency, and heart rate showed a steady downward trend over the entire survival period. Total arterial oxygen and carbon dioxide, and arterial pH decreased midway through the survival time, while

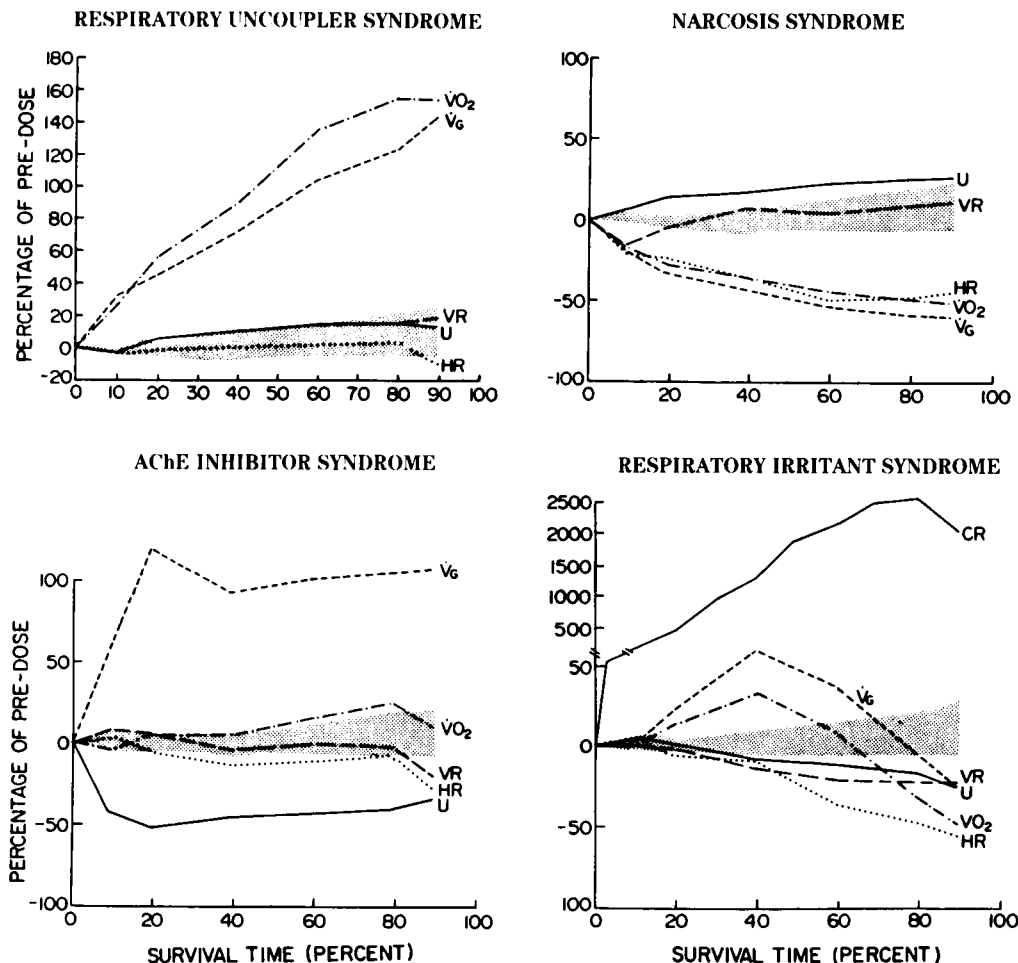

FIGURE 6. Rainbow trout respiratory-cardiovascular response sets representative of four FATS. Ventilation volume (V_G), ventilation rate (VR), total oxygen consumption (VO_2), oxygen uptake efficiency (U), and heart rate (HR) expressed as a percentage change from predose values vs. survival time. The shaded areas in all four figures represent maximum range observed with all five measurements in the controls. Each measurement is a mean of four trout. Modified from McKim et al. (20,21).

hematocrit increased steadily and hemoglobin remained within the control range (Fig. 7). These respiratory-cardiovascular responses are comparable to earlier studies and provide evidence supportive of a general hypoxic effect (70-73) caused by direct gill damage. A significant decrease in plasma osmolality, which was tied to a significant decrease in $[Na^+]_p$ and $[Cl^-]_p$, was also representative of the respiratory irritant syndrome. Losses of plasma ions were previously shown to be associated with gill damage (74-78).

In conclusion, the responses monitored on whole-animal systems exposed to acutely lethal concentrations of these eight chemicals provided the necessary information to initially establish four FATS: a respiratory uncoupler syndrome, a narcosis syndrome, an AChE inhibitor syndrome, and a respiratory irritant syndrome. Stepwise DFA was used in an effort to develop a system that would classify chemicals into FATS based on sets of toxic responses (20,21). The use of DFA with the physiological responses of the 32 trout resulted in a 100% separation of the four specific FATS (Fig. 8).

Of the 18 responses monitored and used in the DFA, cough rate, total oxygen consumption, oxygen uptake efficiency, total arterial oxygen, and arterial pH were the best discriminators for classifying each fish into the correct FATS. In addition, 15 of the 18 variables were significant ($p < 0.05$) discriminators of the FATS, which indicates that most of the response variables could be used as potential discriminators.

Using the experimental procedures outlined, the acute toxic responses of fenvalerate, a Type II pyrethroid insecticide, were subsequently evaluated (22). The synthetic pyrethroids are generally accepted to act as neurotoxicants in mammals and insects (79). Specific hypotheses regarding pyrethroid mode of action include interactions with: sodium channels (80,81), the γ -aminobutyric acid-receptor-ionophore complex (82-84), and ATPase-utilizing systems (85,86). Thus, the proposed mode of action(s) of these insecticides is unique compared to the initial four FATS.

The physiological responses of rainbow trout to fenvalerate intoxication suggest that, besides effects on the

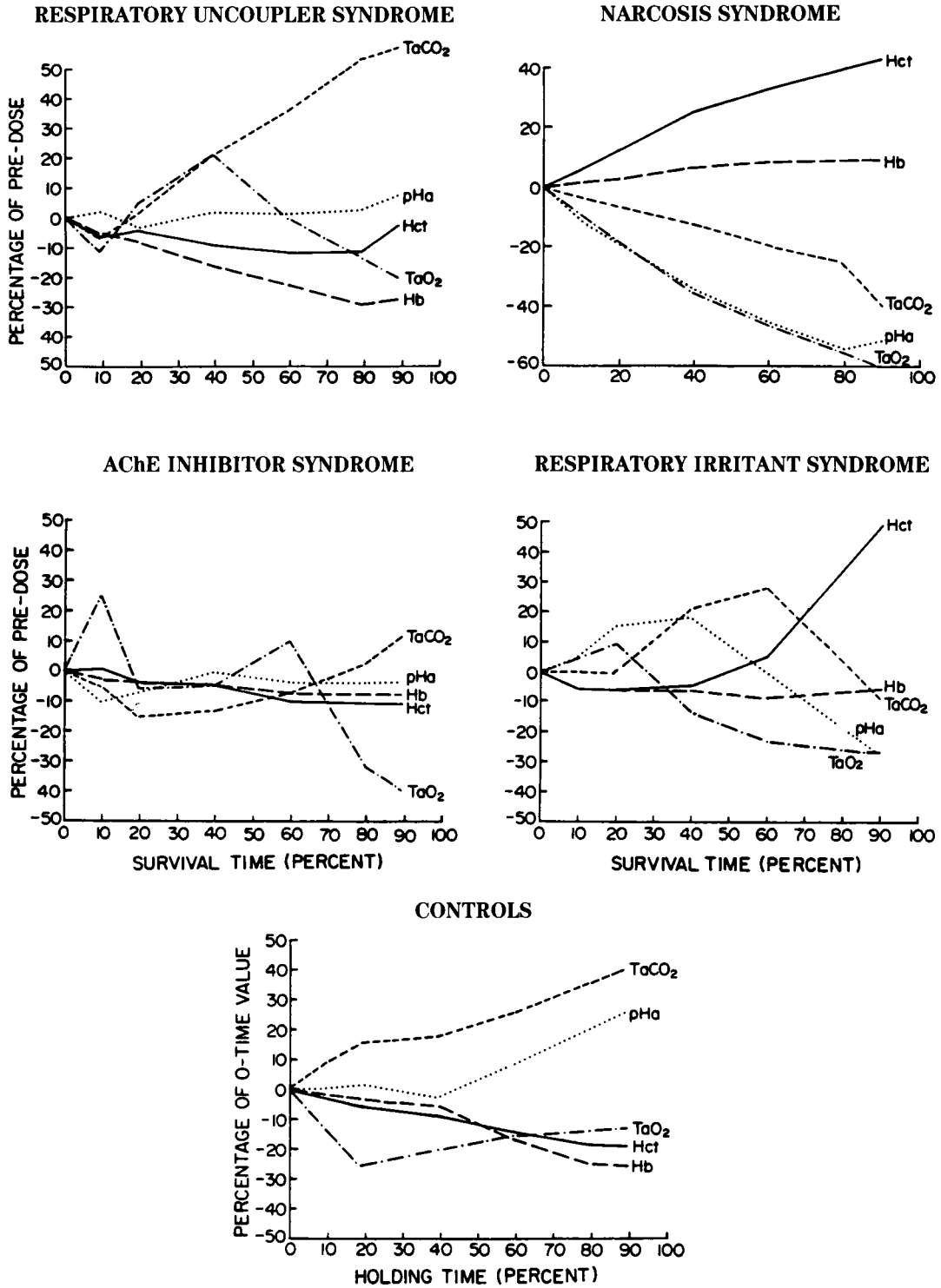

FIGURE 7. Rainbow trout arterial blood response sets representative of four FATS. Arterial pH (pH_a), total arterial oxygen (TaO₂), total arterial carbon dioxide (TaCO₂), hematocrit (Hct), and hemoglobin (Hb) expressed as a percentage change from predose values vs. survival time or holding time for controls. All pH_a values were increased by a factor of 10 to better show fluctuations. Each measurement is a mean of eight trout. Modified from McKim et al. (20,21).

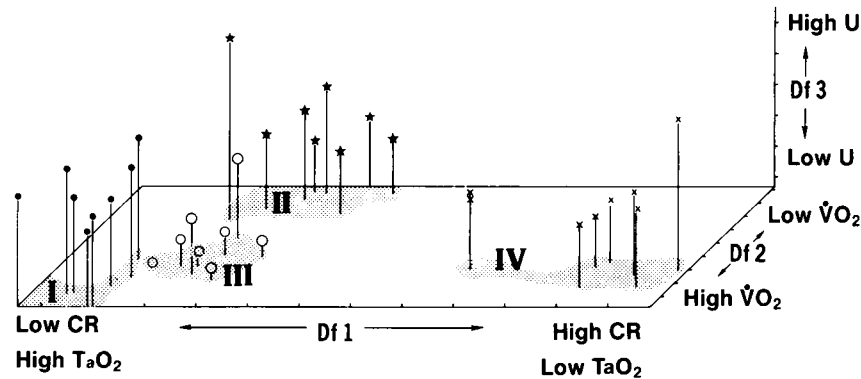

FIGURE 8. Three-dimensional plot of the first three discriminant functions that separate four FATS: respiratory uncoupler syndrome (I), narcosis syndrome (II), AChE inhibitor syndrome (III), respiratory irritant syndrome (IV). Each vertical line represents an individual fish exposed to one of the following eight chemicals: pentachlorophenol and 2,4-dinitrophenol, MS222 and 1-octanol, malathion, and carbaryl, acrolein and benzaldehyde. Modified from McKim et al. (20,21).

nervous system, effects on respiratory surfaces and renal ion regulation may be associated with the mechanism of pyrethroid action in fish.

Visible signs of fenvalerate intoxication included tremors and convulsions. A cessation of ventilatory and cardiac activity was coincident with convulsions; noting these periods of coupled inactivity on physiograph traces permitted a means to quantify convulsions for DFA. An evaluation of blood-chemistry variables indicated an elevated rate of anaerobic metabolism (elevated total arterial oxygen and dropping total arterial carbon dioxide and pH) associated with increasingly severe convulsions. Symptoms characterized by convulsions, bradycardia and increased anaerobic metabolism, have also been reported in mammals following exposure to Type II pyrethroids (87–89) and correlated with central nervous system activity (88,89).

Histological examination of gill tissue suggested damage associated with irritation, which was consistent with an elevated cough rate (205%), decreased oxygen uptake efficiency (–16%), and increased ventilation volume (41%). Similar effects with permethrin, a related pyrethroid, on gill structure have also been reported (90).

Finally, urine osmolality, $[Na^+]$ and $[K^+]$, and Na^+ and K^+ excretion rates were elevated (14 to 74%) with intoxicated trout. The increased excretion of renal Na^+ and K^+ in fenvalerate-exposed rainbow trout indicates that the insecticide may also interfere with ion regulation. An interaction between fenvalerate intoxication and osmoregulation has also been implicated in the estuarine grass shrimp, *Palaemonetes pugio*, (91) and the bluegill (S. Dyer, Iowa State University, Ames, IA, unpublished data). Numerous studies have been published indicating that pyrethroid insecticides are capable of inhibiting a variety of ATPase-utilizing systems, including Ca^{2+} - and $Ca^{2+} + Mg^{2+}$ -ATPase (86), mitochondrial Mg^{2+} -ATPase (92,93), and $Na + K^+$ -ATPase (93). Inhibition of mitochondrial ATPase and/or the Na/K pump in the kidneys could be responsible for the

observed increase in ion loss from intoxicated rainbow trout. Fluctuating internal ion concentrations, especially $[Na^+]$, could accentuate the neurological perturbations associated with the insecticide.

The toxic responses of rainbow trout to fenvalerate were significantly different from response sets obtained after exposure to chemicals from the previously identified FATS. A DFA of these previous data sets ($N = 32$ trout exposed to eight chemicals) combined with the data from fenvalerate-exposed trout resulted in correct classification of individual fish into the FATS previously defined and the delineation of a new response set that solely consisted of those fish exposed to the pyrethroid. The results of the analysis are depicted graphically in a three-dimensional plot (Fig. 9). The best variable for separating the fenvalerate-exposed fish from the fish exposed to the other eight chemicals was convulsions because the first eight toxicants did not elicit this response. This trend is shown in Figure 9, where the fenvalerate-exposed fish are located in the extreme right of discriminant function 1 in the three-dimensional space. Cough rate was also correlated with discriminant function 1 and contributed to the separation of the fenvalerate and gill-irritant groups from the other response sets. The remaining FATS were correctly predicted by discriminant functions 2 and 3, which were related with cough rate, ventilation volume, oxygen uptake efficiency, total arterial oxygen, arterial pH, and plasma $[Ca^{2+}]$ as discussed previously (21). Because a limited number of animals in the other chemical treatment groups were monitored for urinary data, inclusion of these responses in the DFA was not possible. However, individual statistical analyses of responses from control and chemical exposure groups from the original four FATS indicated no consistent changes between control and exposure values for urinary parameters. This also contrasts well with the response of fenvalerate-exposed trout. Further testing is planned to determine what other toxicants are associated with the convulsant FATS developed from fenvalerate.

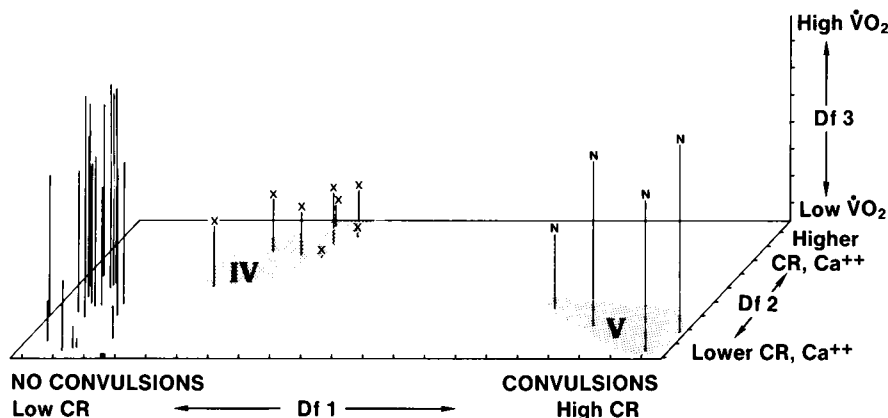

FIGURE 9. Three-dimensional plot of the first three discriminate functions that separate five FATS. Each line represents one fish exposed to one of nine chemicals. The respiratory irritants, acrolein and benzaldehyde (\times), and the convulsant fenvalerate (N) are set off by stipling and represent FATS IV and V, respectively. The respiratory uncoupler syndrome, the narcosis syndrome, and the AChE inhibitor syndrome are 100% resolved as well; however, because of the scaling required to include the fenvalerate response on the plot the separation of these FATS is not readily discerned. Modified from Bradbury et al. (22).

Fish Acute Toxicity Syndromes from the Literature

Experimentally, we have tentatively identified five specific FATS for use in grouping chemicals by mode of action. The number of FATS necessary to aid in the construction of QSAR models for predicting acute toxicity is not known; however, further evaluation of the approach must include an effort to include responses for additional chemicals. As a supplement to continued experimentation, we are exploring the feasibility of using behavioral and physiological-biochemical data already available in the literature to further define and resolve the FATS database.

Using reports in the literature, Niemi and McKim (94) selected zinc sulfate (9) and chlorine (11) as additional respiratory irritants. Rotenone (17,18) and cyanide (15,16) were also selected to evaluate the formation of a new FATS associated with respiratory blockers. By using reported mean and variance estimates (e.g., standard deviation, standard error, or 95% confidence intervals) and assuming normal distributions, a Fortran program was employed to randomly generate exposure and control values for each experimental fish studied. As in the previous experimental studies (20–22), all exposure values were expressed as a percentage change from predose levels and limited to the 25 to 75% survival time. Although McKim et al. (20,21) were able to correctly discriminate four FATS by using 5 of 18 variables, these 5 variables were not always monitored in the selected studies. Therefore, new DFAs of the eight chemicals in the four original FATS were calculated using the suite of variables reported for the respective studies cited above.

Analysis including zinc sulfate and chlorine, with 6 of the original 18 variables (Table 4), indicated that the response set associated with each of these compounds corresponded to the respiratory irritant syndrome (Fig.

8). By using the five common variables available for rotenone, cyanide, and the chemicals represented by the original FATS, DFA was performed to determine whether we could discriminate a new FATS group associated with respiratory blockers. Using four of the five variables we could discriminate 83% (39 of 47) of the fish exposed to the chemicals representing five FATS. Total oxygen consumption and blood oxygen levels were the two best discriminators and they primarily separated the narcotics, uncouplers, AChE inhibitors, and the new group of respiratory blockers. Ventilation rate and blood pH were the other two variables to enter the DFA and in combination they further separated one uncoupler-exposed fish and one irritant-exposed fish in the DFA. One of the primary reasons for the lack of discrimination among these five FATS was that several of the best variables for separating irritants (e.g., cough response) or AChE inhibitors were not available in the rotenone and cyanide studies. All but one of the blockers was correctly classified, and we have shown in our previous work (21) that the four original FATS can also be discriminated if the proper suite of variables is available. Figure 10 illustrates the orientation of these FATS with respect to the DFA space.

Acute–Chronic Extrapolations

The previous sections of this review have dealt exclusively with acute toxicity; however, long-term (chronic) toxicity is also of great concern. Reviews of the extensive chronic-toxicity database for fish have shown that in most cases the early life stages are the most sensitive to waterborne toxicants (95,96). Thus, the use of short duration (30-day) early life-stage tests to effectively predict chronic toxicity has become routine. Call et al. (97) gathered early life-stage toxicity data on 10 narcotic type chemicals for which acute toxicity data were also available. These workers defined a

Table 4. Means and (standard deviations) for the fish physiological variables available in the literature for four chemicals^a.

Code	Variable description	Chlorine (11)	Zinc sulfate (9)	Rotenone (17,18)	Cyanide (15,16)
HR	Heart rate	-55.9 (3.5)	-31.1 (43.2)	NA	-32.3 (6.8)
VR	Ventilation rate	21.7 (10.4)	46.6 (49.3)	151.8 (88.5)	-45.2 (3.5)
CR	Cough rate	1524.6 (589.2)	1008.0 (646.6)	NA	NA
TaO ₂	Blood oxygen (aortic)	-60.1 (4.4)	-55.6 (29.4)	80.2 (34.8)	200.9 (106.3)
HCT	Hematocrit	48.6 (3.6)	NA	35.5 (23.7)	-16.1 (10.8)
V _G	Ventilation volume	NA	175.7 (3.0)	NA	NA
U	Oxygen utilization	NA	-62.6 (31.9)	NA	NA
pH _a	Blood pH (arterial)	-4.1 (0.2)	NA	-3.1 (2.7)	-3.2 (1.3)
TaCO ₂	Blood CO ₂ (arterial)	NA	NA	NA	-54.2 (11.2)
VO ₂	Total oxygen consumption	NA	NA	-56.7 (5.3)	-54.1 (3.7)

^a Expressed as percentages relative to control or predose organisms; NA = not available.

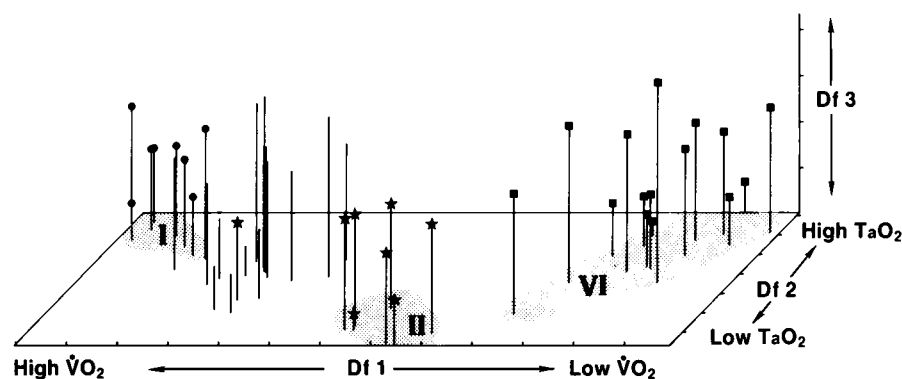

FIGURE 10. Three-dimensional plot of the first three discriminate functions that separate a sixth FATS (respiratory blocker syndrome). Each line represents one fish exposed to one of ten chemicals. The respiratory uncoupler syndrome (I), the narcosis syndrome (II), and the respiratory blocker syndrome (VI) are clearly separated by the five variables available for the respiratory blockers. The lines in the unshaded area represent the AChE inhibitor syndrome and the respiratory irritant syndrome fish, which are not visually separated because of scaling.

relationship between the maximum acceptable toxicant concentration (MATC) and $\log P$ as in Eq. (2):

$$\begin{aligned} \text{Log estimated MATC (mole/L)} \\ = -0.886 \log P - 2.18 \quad (2) \\ (r^2 = 0.925) \end{aligned}$$

This equation was then tested for its applicability by predicting the chronic toxicities of eight other narcotic type chemicals for which chronic values were already available in the literature (97). Their results showed that the above equation predicted the chronic toxicities of these chemicals within a factor of two. A bilinear plot of $\log P$ versus the acute and chronic toxicity (Fig. 11) data on all 18 narcotic chemicals showed essentially par-

allel lines and indicated the same effects of $\log P$ on both toxicity endpoints. Concentrations of the chemicals involved with acute toxicity were approximately an order of magnitude above those causing chronic toxicity (Fig. 11). This similarity in response resulted in an acute/chronic ratio of approximately 10 (97). Hence, predicting the acute toxicity of a chemical through the use of FATS and QSAR may be extended by the acute/chronic ratio to predict chronic toxicity, at least in regard to narcotic chemicals. Preliminary data on uncouplers of oxidative phosphorylation indicates a similar parallel relationship between acute and chronic toxicity activity levels (98). These relationships are extremely important for hazard assessment and must be explored further.

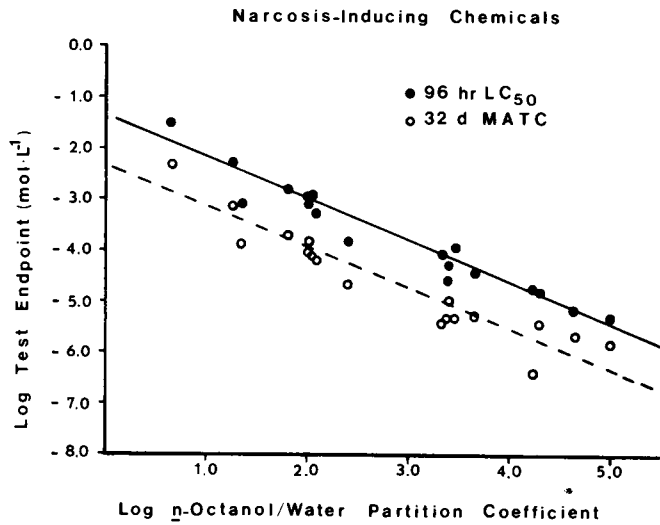

FIGURE 11. Plot of log MATC (mole/L) and log 96-hr LC₅₀ (mole/L) for narcotic type chemicals and the fathead minnow vs. log P. From Call et al. (98).

Conclusions

Based primarily on behavior and respiratory-cardiovascular parameters, the protocol and initial database to describe and resolve whole-organism responses to intoxication by industrial chemicals is being developed. Additional efforts using more specific biochemical and histopathological end points also seem to hold promise

(G. Christensen, V. Snarski, and N. Stokes, U. S. EPA, Environmental Research Laboratory-Duluth, Duluth, MN, unpublished data). Thus far, the behavioral-response sets described for the fathead minnow predict three distinct FATS; however, the FATS assignments based on this approach must be expanded and evaluated by physiological-biochemical response sets. The FATS developed with rainbow trout and primarily based on respiratory-cardiovascular parameters can be reliably assigned to specific modes of action. The syndromes defined at this point are associated with AChE inhibitors, narcotics, oxidative phosphorylation uncouplers, respiratory membrane irritants, respiratory blockers, and convulsants. Future research should include investigations that combine behavioral and physiological response sets to provide for more reliable FATS identification. To enlarge the chemical database and further verify our approach, a continued effort to use data available in the literature will be necessary. In addition, we are currently perfecting a computer-based automated exposure system that can gather and analyze much of the respiratory-cardiovascular data from the rainbow trout model. Development of this system will enhance the generation of experimental data.

The creation of a mode-of-action SAR will be crucial in effectively employing a computer-assisted predictive model for hazard assessment as it relates to general systemic toxicity (Fig. 12). With the correct assignment of a chemical structure to a FATS, the proper mode of action and QSAR model can be invoked. Results of the QSAR models will then provide acute toxicity esti-

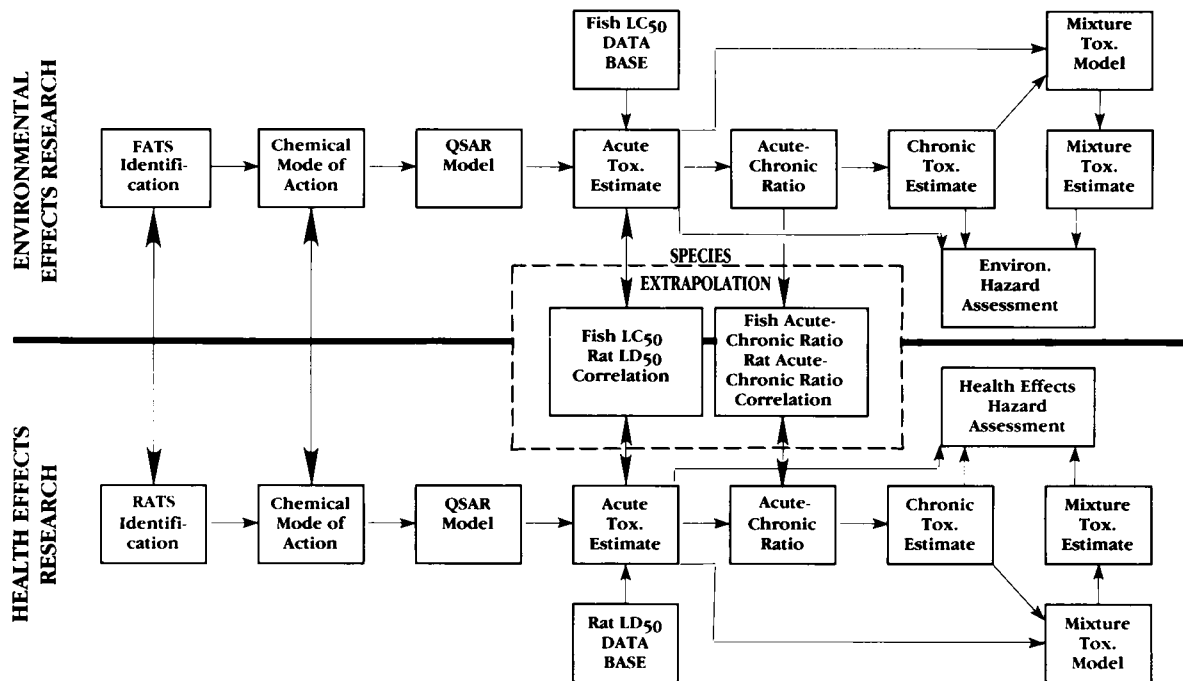

FIGURE 12. Flow chart illustrating specific elements of the FATS-QSAR approach to predictive general systemic toxicology and hazard assessment. (FATS: fish acute toxicity syndrome; RATS: rat acute toxicity syndrome.)

mates. In some instances toxicity data may be available and/or toxicity testing may be required to provide an experimental estimate of lethality. From the acute estimates, models associated with mixture toxicity and chronic toxicity could also be developed.

In addition to providing the foundation for hazard assessment in aquatic toxicology, development of the FATS database will also be a crucial component in species extrapolation initiatives. Conceivably, a predictive relationship between response-sets/modes of action in aquatic vertebrates and mammalian species may be formulated. An understanding of these relationships could mutually assist efforts in hazard assessment of human health and the aquatic environment by providing a link between respective QSAR models and their associated databases. Of course, cross-species predictions of toxic mechanisms will not be of use if the needed QSAR models are not formulated with the species of interest. Current research indicates that reliable extrapolations between fish and mammalian species, based on acute lethality, is possible (99) and, presumably, extrapolations of chronic toxicity for use in screening chemicals can also be developed.

The authors thank Ms. Shelley Heintz for typing the manuscript.

REFERENCES

- Klaverkamp, J. F. The physiological pharmacology and toxicology of fish cardiovascular systems. In: *Aquatic Toxicology*, Vol. 1 (L. J. Weber, Ed.), Raven Press, New York, 1982, pp. 1-54.
- Neff, J. M. Use of biochemical measurements to detect pollution-mediated damage to fish. In: *Aquatic Toxicology and Hazard Assessment: Seventh Symposium*. ASTM STP 854 (R. D. Cardwell, R. Purdy, and R. C. Bahner, Eds.), American Society for Testing and Materials, Philadelphia, 1985, pp. 155-183.
- Macek, K. J., Birge, W., Mayer, F. L., Buikema, A. H., and Maki, A. W. Discussion session synopsis of the use of aquatic toxicity tests for evaluation of the effects of toxic substances. In: *Estimating the Hazard of Chemical Substances to Aquatic Life*: ASTM STP 657 (J. Cairns, K. L. Dickson, and A. W. Maki, Eds.), American Society for Testing and Materials, Philadelphia, 1978, pp. 27-32.
- Mehrle, P. M., and Mayer, F. L. Clinical tests in aquatic toxicology: state of the art. *Environ. Health Perspect.* 34: 139-143 (1980).
- Mayer, F. L. Clinical tests in aquatic toxicology: a paradox? *Environ. Toxicol. Chem.* 2: 139-140 (1983).
- Pfuderer, P., and Francis, A. A. Phthalate esters: heart rate depressors in the goldfish. *Bull. Environ. Contam. Toxicol.* 13: 275-279 (1975).
- Pfuderer, P., Janzen, S., and Rainey, W. T., Jr. The identification of phthalic acid esters in the tissues of cyprinodon fish and their activity as heart rate depressors. *Environ. Res.* 9: 215-223 (1975).
- Pfuderer, P., Williams, P., and Francis, A. A. partial purification of the crowding factor from *Carassius auratus* and *Cyprinus carpio*. *J. Exptl. Zool.* 187: 375-382 (1974).
- Skidmore, J. F. Respiration and osmoregulation in rainbow trout with gills damaged by zinc sulphate. *J. Exptl. Biol.* 52: 482-494 (1970).
- Hughes, G. M., and Adeney, R. J. The effects of zinc on the cardiac and ventilatory rhythms of rainbow trout, *Salmo gairdneri* (Richardson), and their responses to environmental hypoxia. *Water Res.* 11: 1069-1077 (1977).
- Bass, M. L., and Heath, A. G. Cardiovascular and respiratory changes in rainbow trout, *Salmo gairdneri*, exposed intermittently to chlorine. *Water Res.* 11: 479-502 (1977).
- Smart, G. R. Investigations of the toxic mechanism of ammonia to fish-gas exchange in rainbow trout, *Salmo gairdneri*, exposed to acutely lethal concentrations. *J. Fish. Biol.* 12: 93-104 (1978).
- Lochowitz, R. T., Miles, H. M., and Hafemann, D. R. Anesthetic-induced variations in the cardiac rate of the teleost, *Salmo gairdneri*. *Comp. Gen. Pharmac.* 5: 217-224 (1974).
- Duangswasadi, M., and Klaverkamp, J. F. Acephate and tetrothion toxicity in rainbow trout: effects of temperature stress and investigations on the sites of action. In: *Aquatic Toxicology*, ASTM STP 667 (L. L. Marking and R. A. Kimerle, Eds.), American Society for Testing and Materials, Philadelphia, 1979, pp. 35-51.
- Jones, J. R. E. The oxygen consumption of *Gasterosteus aculeatus* L. in toxic solutions. *J. Exptl. Biol.* 23: 298-311 (1947).
- Hunn, J. B. The effects of exposure to thanite on the blood chemistry of carp. *Progr. Fish. Cult.* 34: 81-84 (1972).
- Dannell, R. Z. Impact of rotenone on fish respiration. *Vergl. Physiol.* 18: 524-535 (1933).
- Perry, J. W., and Conway, M. W. Rotenone induced blood respiratory changes in the green sunfish, *Lepomis cyanellus*. *Comp. Biochem. Physiol.* 56C: 123-126 (1977).
- Drummond, R. A., Russom, C. L., Geiger, D. L., and DeFoe, D. L. Behavioral and morphological changes in fathead minnows, *Pimephales promelas*, as diagnostic endpoints for screening chemicals according to mode of action. In: *Aquatic Toxicology*. 9th Aquatic Toxicity Symposium, American Society for Testing and Materials, Philadelphia, 1986, in press.
- Mckim, J. M., Schmieder, P. K., Carlson, R. W., Hunt, E. P., and Niemi, G. J. Use of respiratory-cardiovascular responses of rainbow trout (*Salmo gairdneri*) in identifying fish acute toxicity syndromes. Part I. Pentachlorophenol, 2,4-dinitrophenol, tricaine methanesulfonate, and 1-octanol. *Environ. Toxicol. Chem.*, in press.
- McKim, J. M., Schmeider, P. K., Niemi, G. J., Carlson, R. W., and Henry, T. R. Use of respiratory-cardiovascular responses of rainbow trout (*Salmo gairdneri*) in identifying fish acute toxicity syndromes. Part II. Malthion, carbaryl, acrolein, and benzaldehyde. *Environ. Toxicol. Chem.*, in press.
- Bradbury, S. P., McKim, J. M., and Coats, J. R. Physiological response of rainbow trout (*Salmo gairdneri*) to acute fenvalerate intoxication. *Pestic. Biochem. Physiol.*, in press.
- McCutcheon, R. S. Toxicology and the law. In: *Casarett and Doull's Toxicology. The Basic Science of Poisons*, 2nd ed. (J. Doull, C. D. Klassen, and M. O. Amdur, Eds.), Macmillan Publishing Co., New York, 1980, pp. 727-735.
- Veith, G. D., DeFoe, P., and Knuth, M. Structure-activity relationships for screening organic chemicals for potential ecotoxicity effects. *Drug Metab. Rev.* 15: 1295-1303 (1984).
- Veith, G. D., Call, D. J., and Brooke, L. T. Structure-toxicity relationships for the fathead minnow: narcotic industrial chemicals. *Can. J. Fish. Aquat. Sci.* 40: 743-748 (1983).
- Roth, S. H. Membrane and cellular actions of anesthetic agents. *Fed. Proc.* 39: 1595-1599 (1980).
- Hesser, C. M., Fagraeus, A., and Adolfson, J. Roles of nitrogen, oxygen and carbon dioxide in compressed air narcosis. *Undersea Biomed. Res.* 5: 391-400 (1978).
- Crisp, D. J., Christie, A. O., and Ghobasky, A.F.A. Narcotic and toxic action of organic compounds on barnacle larvae. *Comp. Biol. Physiol.* 22: 629-645 (1967).
- Albert, A. *Selective Toxicity*, 3rd ed. John Wiley & Sons, New York, 1965.
- Gero, A. Intimate study of drug action. III. Possible mechanism of drug action. In: *Drugs Pharmacology in Medicine*. McGraw-Hill, New York 1965, pp. 47-69.
- Ferguson, J. The use of chemical potentials as indices of toxicity. *Proc. Roy. Soc. (London)* B127: 387-404 (1939).
- Mullins, L. J. Some physical mechanisms in narcosis. *Chem. Rev.* 54: 289-323 (1954).
- Konemann, H. Quantitative structure-activity relationships in fish toxicity studies. *Toxicology* 19: 209-221 (1981).
- Hermens, J., Canton, H., Janssen, P., and DeJong, R. Quantitative structure-activity relationships and toxicity studies of mixtures of chemicals with anesthetic potency: acute lethal and sub-

- lethal toxicity to *Daphnia magna*. *Aquat. Toxicol.* 5: 143–154 (1984).
35. Klaasen, C. D., and Doull, J. Evaluation of safety: toxicologic evaluation. In: Casarett and Doull's Toxicology. The Basic Science of Poisons, 2nd ed. (J. Doull, C. D. Klaassen, and M. O. Amdur, Eds.), Macmillan Publishing Co., New York, 1980, pp. 11–27.
 36. Tatsuoka, M. M. Multivariate analysis. John Wiley & Sons, New York, 1971.
 37. U.S. Environmental Protection Agency. The committee on methods for toxicity tests with aquatic organisms. Methods for acute toxicity tests with fish, macroinvertebrates and amphibians. EPA-660/3-75/009, U.S. Environmental Protection Agency, Duluth, MN, 1975.
 38. Steen, J. B., and Kruijse, A. The respiratory function of teleostean gills. *Comp. Biochem. Physiol.* 12: 127–142 (1964).
 39. Farrell, A. P., Sobin, S. S., Randall, D. J., and Crosby, S. Intralamellar blood flow patterns in fish gills. *Am. J. Physiol.* 239: R428–R436 (1980).
 40. Hughes, G. M. Morphometrics of fish gills. *Respir. Physiol.* 14: 1–25 (1972).
 41. Booth, J. H. The effects of oxygen supply, epinephrine, and acetylcholine on the distribution of blood flow in trout gills. *J. Exptl. Biol.* 83: 31–39 (1979).
 42. Booth, J. H. Circulation in trout gills: the relationship between branchial perfusion and the width of the lamellar blood space. *Can. J. Zool.* 57: 2183–2185 (1979).
 43. Nilsson, S. Innervation and pharmacology of the gills. In: Fish Physiology, Vol. X. Gills, Part A (W. S. Hoar and D. J. Randall, Eds.), Harcourt Brace-Jovanovich Publishers, New York, 1984, pp. 185–230.
 44. Daxboeck, C., and David, P. S. Effects of pulsatile perfusion on flow distribution within an isolated saline-perfused trout head preparation. *Can. J. Zool.* 60: 994–999 (1982).
 45. Morrison, J. K. The effects of pentachlorophenol on liver and gills of cutthroat trout (*Salmo clarkii*). Masters thesis, Montana State University, 1983.
 46. McFarland, W. N. A study of the effects of anesthetics on the behavior and physiology of fishes. Institute of Marine Science, University of Texas, 1959, pp. 23–55.
 47. Smit, G. L., Hattingh, J., and Burger, A. P. Haematological assessment of the effects of the anaesthetic MS222 in natural and neutralized form in three freshwater fish species: interspecies differences. *J. Fish. Biol.* 15: 633–643 (1979).
 48. Soivio, A., Westman, K., and Nyholm, K. The influence of changes in oxygen tension on the haematocrit value of blood samples from asphyxial rainbow trout (*Salmo gairdneri*). *Aquaculture* 3: 395–401 (1974).
 49. Soivio, A., Westman, K., and Nyholm, K. Changes in haematocrit values in blood samples treated with and without oxygen: a comparative study with four salmonid species. *J. Fish. Biol.* 6: 763–769 (1974).
 50. Nieminen, M., Laitinen, M., and Pasanen, P. Effects of anaesthesia with tricaine (MS222) on the blood composition of the splake (*Salvelinus fontinalis* X *Salvelinus namaycush*). *Comp. Biochem. Physiol.* 73C: 271–276 (1982).
 51. Houston, A. H., Madden, J. A., Woods, R. J., and Miles, H. M. Some physiological effects of handling and tricaine methanesulphonate anesthetization upon the brook trout, *Salvelinus fontinalis*. *J. Fish. Res. Board Can.* 28: 625–633 (1971).
 52. Soivio, A., Nyholm, K., and Huhti, M. Effects of anaesthesia with MS222, neutralized MS222 and benzocaine on the blood constituents of rainbow trout, *Salmo gairdneri*. *J. Fish. Biol.* 10: 91–101 (1977).
 53. Duangswasadi, M., and Klaverkamp, J. F. Acephate and fenitrothion toxicity in rainbow trout: effects of temperature stress and investigations on the sites of action. In: Aquatic Toxicology. ASTM STP 667 (L. L. Marking and R. D. Kimerle, Eds.), American Society for Testing and Materials, Philadelphia, 1979, pp. 35–51.
 54. Bergman, H. L., Olson, K. R., and Fromm, P. O. The effects of vasoactive agents on the functional surface area of isolated perfused gills of rainbow trout. *J. Comp. Physiol.* 94: 267–286 (1974).
 55. Wood, C. M. A pharmacological analysis of the adrenergic and cholinergic mechanisms regulating branchial vascular resistance in the rainbow trout (*Salmo gairdneri*). *Can. J. Zool.* 53: 1569–1577 (1975).
 56. Smith, D. G. Sites of cholinergic vasoconstriction in trout gills. *Am. J. Physiol.* 233: R222–R229 (1977).
 57. Booth, J. H. The effects of oxygen supply, epinephrine, and acetylcholine on the distribution of blood flow in trout gills. *J. Exptl. Biol.* 83: 31–39 (1979).
 58. Booth, J. H. Circulation in trout gills: the relationship between branchial perfusion and the width of the lamellar blood space. *Can. J. Zool.* 57: 2183–2185 (1979).
 59. Holbert, P. W., Boland, E. J., and Olson, K. R. The effect of epinephrine and acetylcholine on the distribution of red cells within the gills of the channel catfish (*Ictalurus punctatus*). *J. Exptl. Biol.* 79: 135–146 (1979).
 60. Dunel, S., and Laurent, P. Physiologie comparée: la vascularisation branchiale chez l'anguille: action de l'acetylcholine et de l'adrenaline sur la repartition d'une résine polymérisable dans les différents compartiments vasculaires. *C. R. Acad. Sci. (Paris)* 284: 2011–2014 (1977).
 61. Nilsson, S. Innervation and pharmacology of the gills. In: Fish Physiology, Vol. X. Gills, Part A (W. S. Hoar and D. J. Randall, Eds.), Harcourt Brace Jovanovich Publishers, New York, 1984, pp. 185–230.
 62. Falck, B., von Mecklenberg, C., Myhrberg, H., and Persson, H. Studies on adrenergic and cholinergic receptors in the isolated hearts of *Lampetra fluviatilis* (Cyclostomate) and *Pleuronectes platessa* (Teleostei). *Acta Physiol. Scand.* 68: 64–71 (1966).
 63. Randall, D. J. The nervous control of cardiac activity in the tench (*Tinca tinca*) and the goldfish (*Carassius auratus*). *Physiol. Zool.* 39: 185–192 (1966).
 64. Randall, D. J. The circulatory system. *Fish Physiology*, Vol. IV (W. S. Hoar and D. J. Randall, Eds.), Academic Press, New York, 1970, pp. 133–172.
 65. Stuart, R. E., Hedtke, J. L., and Weber, L. J. Physiological and pharmacological investigation of the nonvascularized marine teleost heart with adrenergic and cholinergic agents. *Can. J. Zool.* 61: 1944–1948 (1983).
 66. Sastry, K. V., and Siddiqui, A. A. Chronic toxic effects of the carbamate pesticide sevin on carbohydrate metabolism in a freshwater snakehead fish, *Channa punctatus*. *Toxicol. Letters* 14: 123–130 (1982).
 67. Jayantha Rao, K., Madhu, Ch., and Murthy, V.S.R. Histopathology of malathion on gills of a freshwater teleost, *Tilapia mossambica* (Peters). *J. Environ. Biol.* 4: 9–13 (1983).
 68. Koundinya, P. R., and Ramamurthi, R. Tissue respiration in *Tilapia mossambica* exposed to lethal (LC50) concentration of sumithion and sevin. *Indian J. Environ. Health* 20: 126 (1978).
 69. Skidware, J. F., and Tovell, P. W. A. Toxic effects of zinc sulfate on the gills of rainbow trout. *Water Res.* 6: 217–230 (1972).
 70. Randall, D. J., and Shelton, G. The effects of changes in environmental gas concentrations on the breathing and heart rate of a teleost fish. *Comp. Biochem. Physiol.* 7: 229–239 (1963).
 71. Marvin, D. E., and Heath, A. G. Cardiac and respiratory responses to gradual hypoxia in three ecologically distinct species of freshwater fish. *Comp. Biochem. Physiol.* 27: 349–355 (1968).
 72. Hughes, G. M. Respiratory responses to hypoxia in fish. *Am. Zool.* 13: 475–489 (1973).
 73. Randall, D. J. The control of respiration and circulation in fish during exercise and hypoxia. *J. Exptl. Biol.* 100: 275–288 (1982).
 74. McKim, J. M., Christensen, G. M., and Hunt, E. P. Changes in the blood of the brook trout (*Salvelinus fontinalis*) after short-term and long-term exposure to copper. *J. Fish. Res. Board Can.* 27: 1883–1889 (1970).
 75. Wedemeyer, G. A., Nelson, N. C., and Yasutake, W. T. Physiological and biochemical aspects of ozone toxicity to rainbow trout (*Salmo gairdneri*). *J. Fish. Res. Board Can.* 36: 605–614 (1975).
 76. Lewis, S. E., and Lewis, W. M. The effect of zinc and copper on the osmolality of blood serum of the channel catfish, *Ictalurus punctatus* Rafinesque, and golden shiner, *Notemigonus crysoleucas* (Mitchill). *Trans. Am. Fish. Soc.* 100: 639–643 (1971).
 77. Hobe, H., Wood, C. M., and McMahon, B. R. Mechanisms of acid-base and ionoregulation in white suckers (*Catostomus com-*

- mersoni*) in natural soft water. I. Acute exposure to low ambient pH. *J. Comp. Physiol.* B154: 35-46 (1984).
78. Lauren, D. J., and McDonald, D. G. Effects of copper on branchial ionoregulation in the rainbow trout, *Salmo gairdneri* (Richardson). Modulation by water hardness and pH. *J. Comp. Physiol.* B155: 1-10 (1985).
 79. Casida, J. E., Gammon, D. W., Glickman, A. H., and Lawrence, L. J. Mechanisms of selective action of pyrethroid insecticides. *Ann. Rev. Pharmacol. Toxicol.* 23: 413-438 (1983).
 80. Narahashi, T. Nerve membrane sodium channels as the major target site of pyrethroids and DDT. In: *Mode of Action. Metabolism, and Toxicology. Vol. 3. Pesticide Chemistry: Human Welfare and the Environment* (J. Miyamoto and P. C. Kearney, Eds.), Pergamon Press, New York, 1983, pp. 109-114.
 81. Lund, A. E., and Narahashi, T. Kinetics of sodium channel modification as the basis for the variation in the nerve membrane effects of pyrethroids and DDT analogs. *Pestic. Biochem. Physiol.* 20: 203-216 (1983).
 82. Cole, L. W., Lawrence, L. J., and Casida, J. E. Similar properties of ^{35}S -*t*-butylbicyclophosphorothioate receptor and coupled components of the GABA receptor-ionophore complex in brains of human, cow, rat, chicken, and fish. *Life Sci.* 35: 1755-1762 (1984).
 83. Lawrence, L. J., and Casida, J. E. Stereospecific action of pyrethroid insecticides on the γ -aminobutyric and receptor-ionophore complex. *Science* 221: 1399-1401 (1983).
 84. Lawrence, L. J. Toxicology of pyrethroid and chlorinated insecticides: Stereospecific interactions with brain specific \pm -butylbicyclophosphorothioate receptor. Ph.D. Dissertation. University of California, Berkeley, Berkeley, CA, 1983.
 85. Matsumura, F. Influence of chlorinated and pyrethroid insecticides as cellular calcium regulation mechanisms. In: *Mode of Action, Metabolism, and Toxicology, Vol. 3. Pesticide Chemistry: Human Welfare and the Environment* (J. Miyamoto and P. C. Kearney, Eds.), Pergamon Press, New York, 1983, pp. 109-114.
 86. Clark, J. M., and Matsumura, F. Two different types of inhibitory effects of pyrethroids on nerve Ca- and Ca + Mg-ATPase activity in squid, *Loligo pealei*. *Pestic. Biochem. Physiol.* 18: 180-190 (1982).
 87. Cremer, J. E., and Seville, M. P. Comparative effects of two pyrethroids, deltamethrin and cismethrin, on plasma catecholamines and on blood glucose and lactate. *Toxicol. Appl. Pharmacol.* 66: 124-133 (1982).
 88. Ray, D. E., and Cremer, J. E. The action of decamethrin (a synthetic pyrethroid) on the rat. *Pestic. Biochem. Physiol.* 10: 333-340 (1979).
 89. Ray, D. E. An EEG investigation of decamethrin-induced choreoathetosis in the rat. *Exptl. Brain. Res.* 38: 221-227 (1980).
 90. Kumuraguru, A. K., Beamish, F. W. H., and Ferguson, W. H. Direct and circulatory paths of permethrin (NRDC-143) causing histopathological changes in the gills of rainbow trout, *Salmo gairdneri* Richardson. *J. Fish Biol.* 20: 87-91 (1982).
 91. McKenny, C. L., and Hamaker, D. B. Effects of fenvalerate on larval development of *Palaemonetes pugio* (Hothins) and on larval metabolism during osmotic stress. *Aquat. Toxicol.* 5: 343-355 (1984).
 92. El-Sebae, A. H., Sherby, S. I., and Mansour, N. A. Gossypol as an inducer or inhibitor in *Spodoptera littoralis* larvae. *Environ. Sci. Health B16*: 167-168 (1981).
 93. Desai, D., Cutkomp, L. K., Veal, E. V., and Koch, R. B. The effect of three pyrethroids on ATPase of insects and fish. *Gen. Pharmacol.* 6: 31-34 (1975).
 94. Niemi, G. J., and McKim, J. M. The use of fish physiology literature for predicting fish acute toxicity syndromes. In preparation.
 95. Macek, K. J., and Sleight, B. H., III. Utility of toxicity tests with embryos and fry of fish in evaluating hazards associated with the chronic toxicity of chemicals to fishes. In: *Aquatic Toxicology and Hazard Evaluation, ASTM STP 634* (F. L. Mayer and J. L. Hamelink, Eds.), American Society for Testing and Materials, Philadelphia, 1977, pp. 137-146.
 96. McKim, J. M. Evaluation of tests with early life stages of fish for predicting long-term toxicity. *Can. J. Fish. Aquat. Sci.* 34: 1148-1154 (1977).
 97. Call, D. J., Brooke, L. T., Knuth, M. L., Poirier, S. H., and Hoglund, M. D. Fish subchronic toxicity prediction model for industrial organic chemicals that produce narcosis. *Environ. Toxicol. Chem.* 4: 335-341 (1985).
 98. Call, D. J., Poirier, S. H., Harting, S. L., Lindberg, C. A., Northcott, C. E., and Brooke, L. T. Acute and subchronic toxicities of several phenolic uncouplers of oxidative phosphorylation in fathead minnows. (*Pimephales promelas*). *Environ. Toxicol. Chem.*, submitted.
 99. Wallace, K. B., and Niemi, G. J. Chemical determinants of error in extrapolating acute toxicity between fish and rodents. *Fund. Appl. Toxicol.*, submitted.