

## Fixed scattering section length with variable scattering section dispersion based optical fibers for polarization mode dispersion penalties

Mahmoud M. A. Eid<sup>1</sup>, Ahmed Nabih Zaki Rashed<sup>2</sup>

<sup>1</sup>Department of Electrical Engineering, College of Engineering, Taif University, Kingdom of Saudi Arabia,

<sup>2</sup>Electronics and Electrical Communications Engineering Department Faculty of Electronic Engineering, Menoufia University, Egypt

### Article Info

#### Article history:

Received Apr 15, 2020

Revised Jun 7, 2020

Accepted Jun 15, 2020

#### Keywords:

Dispersion penalties

Fixed scattering length

Polarization mode dispersion

RZ code

Variable scattering dispersion

### ABSTRACT

This study has clarified the fixed scattering section length with variable scattering section dispersion based optical fibers for polarization mode dispersion penalties at high data rates. The max signal power/min. noise power is simulated against time after fiber length of 500 km with various scattering section dispersion. The overall total light power is simulated after fiber length of 500 km with various scattering section dispersion. In addition to the overall total electrical power is clarified through APD receiver at fiber length of 500 km with various scattering section dispersion. Eye diagram analyzer for signal quality is also simulated through APD receiver at fiber length of 500 km with various scattering section dispersion. The max Q factor, electrical signal power after APD receiver variations against scattering section dispersion variations for various data rates.

*This is an open access article under the [CC BY-SA](https://creativecommons.org/licenses/by-sa/4.0/) license.*



### Corresponding Author:

Ahmed Nabih Zaki Rashed

Faculty of Electronic Engineering

Menouf 32851, Menoufia University, Egypt

E-mail: ahmed\_733@yahoo.com

## 1. INTRODUCTION

Polarization mode dispersion (PMD) in optical channels has been a critical factor limiting high-speed data transmission over long distances in optical networks. PMD is a source of inter symbol interference (ISI) and its impact increases with the transmission data rate [1-5]. Since economical adaptive compensation schemes are currently unavailable, it is essential to characterize this impairment to completely understand its impact and develop effective countermeasures [6-10].

Optical fiber impairments are critical factors limiting high-speed data transmission over long distances in optical communication networks. Impairments in the channel caused by chromatic dispersion and transmission loss have a direct impact on the reach of a network or the quality of transmission at higher bit rates and narrowly spaced channels/the presence of PMD in optical fibers is one of the main factors limiting the capability of a channel to transport high-speed data [11-16]. PMD reduces the reach of networks, and the increased regeneration requirements of optical signals result in expensive network designs [17-22].

To compensate for the degradation in the optical signal caused by these effects the signal may require reconstruction and regeneration over the length of transmission [23-25]. The receiver section detects the optical signal, and the modulated information is recovered. The performance of such a typical optical network configuration is primarily a function of the system components and the transmission media [26-35].

**2. MODEL DESCRIPTION AND RESEARCH METHOD**

Figure 1 clarifies the data bit stream sequences can be encoded with the return to zero coding which represent the first input electrical encoded signal for the electro optic LiNbO<sub>3</sub> modulators. The second input to the modulators is from the continuous wave laser. The third input is the encoded RZ scheme for the bit stream sequence. The laser frequency is 195 THz, laser power is 5 dBm. The modulated signal reaches to the optical fiber medium.

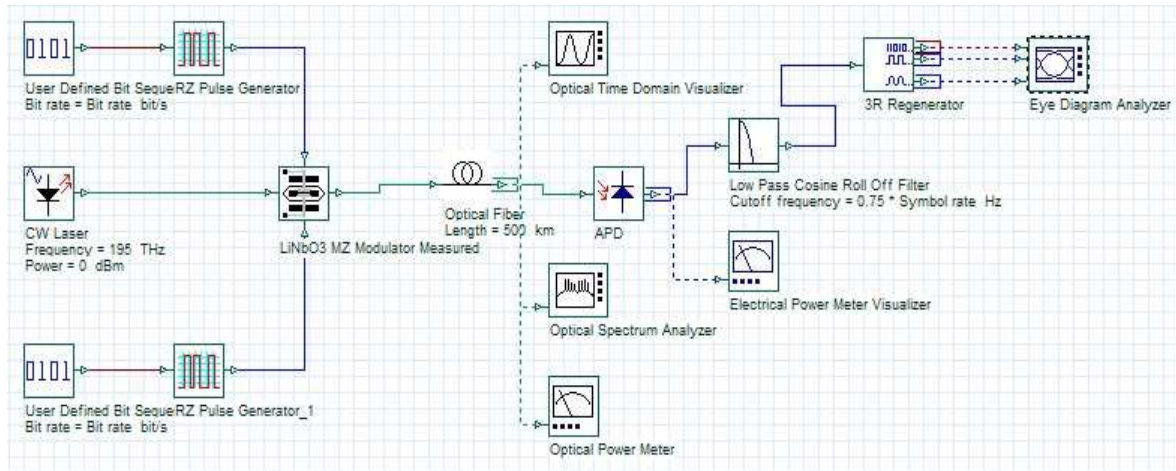

Figure 1. Model simulation description for the study

The optical fiber has a length of 500 km, mean scattering section length of 10000 m, average scattering section dispersion of 50 m, attenuation of 0.2 dB/km. The optical power versus spectral frequency and time domain are measured. The overall total light power is also measured by optical power meter. The light signal can be converted to the electrical signal by avalanche photodiode (APD) receiver. All the unwanted high frequency signals and ripples can be eliminated by low pass Bessel filter. The max Q factor and min. BER can be evaluated and measured by eye diagram analyzers.

**3. PERFORMANCE ANALYSIS WITH DISCUSSIONS**

The overall total light power is simulated after fiber length of 500 km with various scattering section dispersion. In addition to the overall total electrical power is clarified through APD receiver at fiber length of 500 km with various scattering section dispersion. Eye diagram analyzer for signal quality is also simulated through APD receiver at fiber length of 500 km with various scattering section dispersion. The max Q Factor, electrical signal power after APD receiver variations against scattering section dispersion variations for various data rates. Figures 2-4 clarify the max signal power/min. noise power against time after fiber length of 500 km with various scattering section dispersion. Figure 2 shows the max signal power/min. noise power against time after fiber length (500 km) with scattering section dispersion of 10 m. Where the max signal power is 0.0012824 W, min. noise power is  $-6.1 \times 10^{-5}$  W. Figure 3 indicates the max signal power/min. noise power against time after fiber length (500 km) with scattering section dispersion of 50 m. Where the max signal power is 0.0012663 W, min. noise power is  $-6.0298 \times 10^{-5}$  W. Figure 4 clarifies the max signal power/min. noise power against time after fiber length (500 km) with scattering section dispersion of 100 m. Where the max signal power is 0.0012532 W, min. noise power is  $-5.9674 \times 10^{-5}$  W. It is indicated that the increase of scattering section dispersion, this results in the decrease of the max signal power.

Figure 5 show the max signal power/min. noise power against spectral wavelength after fiber length (500 km) with scattering section dispersion of 10 m, 50 m, 100 m. The study emphasized the max signal power is -6.55966 dBm and min. noise power is -90.254 dBm at all values of scattering section dispersion. So the max signal power/min. noise power are the same values at all values of scattering section dispersion. Figure 6 illustrates the overall total light power after fiber length (500 km) with scattering section dispersion of 10 m, 50 m, 100 m. The optical power is 296.172  $\mu$ W or -5.285 dBm at all values of scattering section dispersion. So the optical power is the same values at all values of scattering section dispersion.

Figure 7 demonstrates the overall total electrical power through APD receiver at fiber length (500 km) with scattering section dispersion of 10 m, 50 m, 100 m. The electrical power is 2.356  $\mu$ W or -26.279

dBm at all values of scattering section dispersion. So the electrical power is the same values at all values of scattering section dispersion.

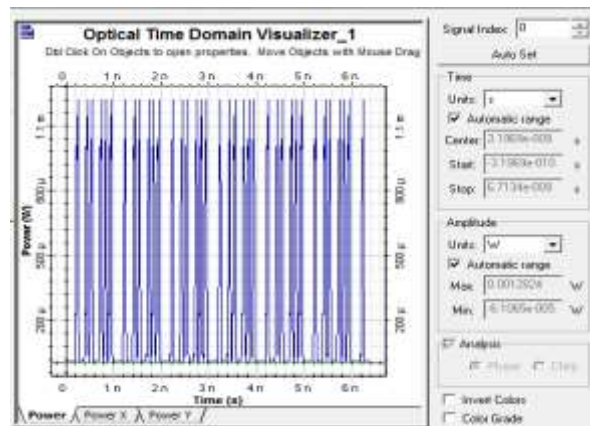

Figure 2. Max signal power/min noise power against time after fiber length (500 km) with scattering section dispersion of 10 m

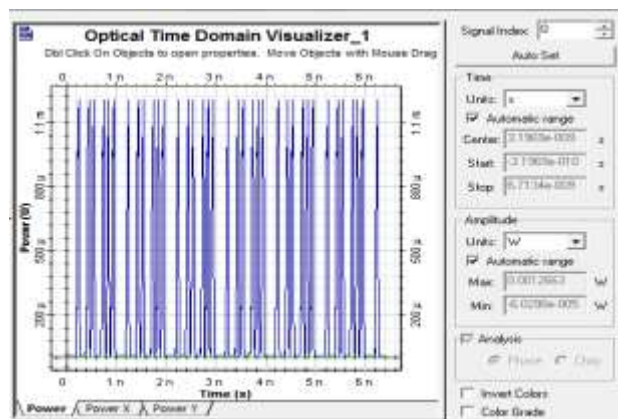

Figure 3. Max signal power/min noise power against time after fiber length (500 km) with scattering section dispersion of 50 m

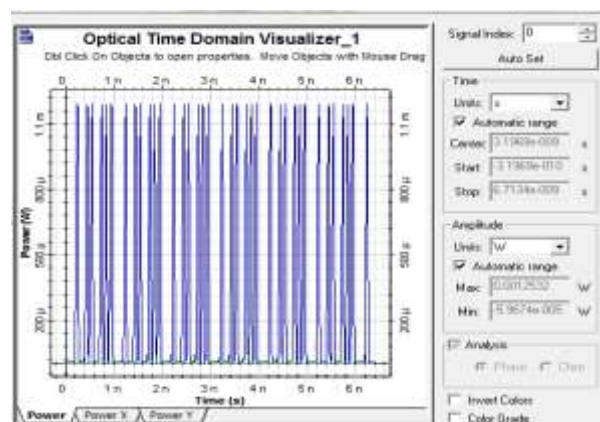

Figure 4. Max signal power/min. noise power against time after fiber length (500 km) with scattering section dispersion of 100 m

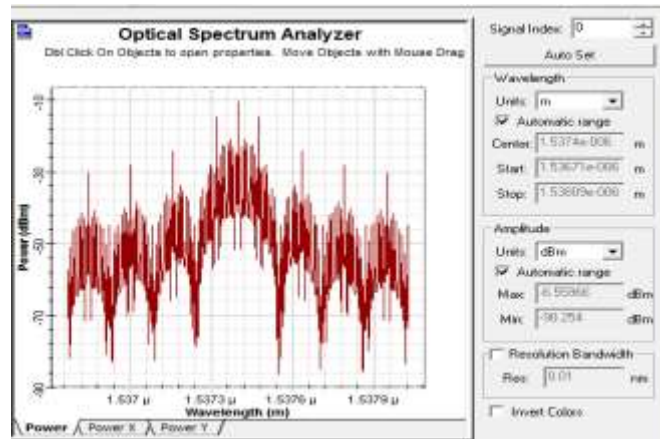

Figure 5. Max signal power/min noise power against spectral wavelength after fiber length (500 km) with scattering section dispersion of 10 m, 50 m, 100 m

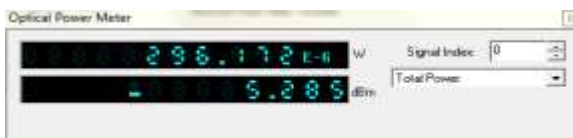

Figure 6. Overall total light power after fiber length (500 km) with scattering section dispersion of 10 m, 50 m, 100 m



Figure 7. Overall total electrical power through APD receiver at fiber length (500 km) with scattering section dispersion of 10 m, 50 m, 100 m

Figures 8-10 illustrate the eye diagram analyzer for signal quality through APD receiver at fiber length (500 km) with various scattering section dispersion. Figure 8 clarifies the eye diagram analyzer for signal quality through APD receiver at fiber length (500 km) with scattering section dispersion of 10 m. Where the max Q Factor is 279.592, min. bit error rate tends to zero. Figure 9 indicates the eye diagram analyzer for signal quality through APD receiver at fiber length (500 km) with scattering section dispersion of 50 m. Where the max Q Factor is 282.513, min bit error rate tends to zero. In addition to Figure 10 demonstrates the eye diagram analyzer for signal quality through APD receiver at fiber length (500 km) with scattering section dispersion of 100 m. Where the max Q Factor is 284.682, min bit error rate tends to zero. The max Q factor is upgraded with the increase of the scattering section dispersion. This is the reason that with the higher the scattering section dispersion, the lower bit rate and consequently the higher signal quality factor.

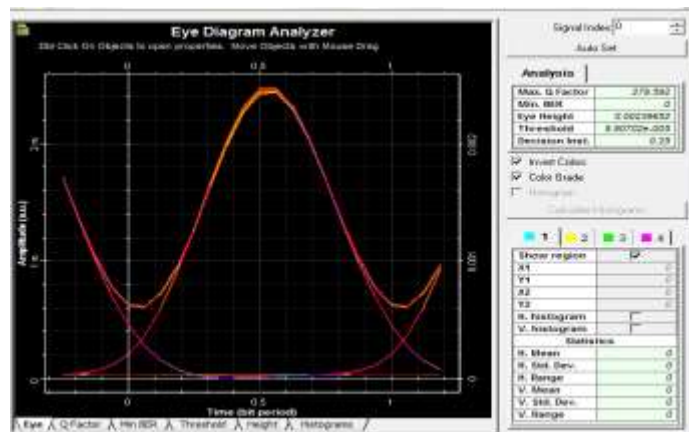

Figure 8. Eye diagram analyzer for signal quality through APD receiver at fiber length (500 km) with scattering section dispersion of 10 m

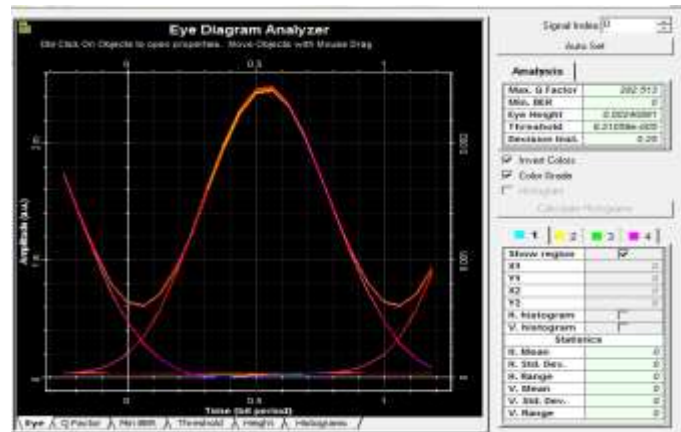

Figure 9. Eye diagram analyzer for signal quality through APD receiver at fiber length (500 km) with scattering section dispersion of 50 m

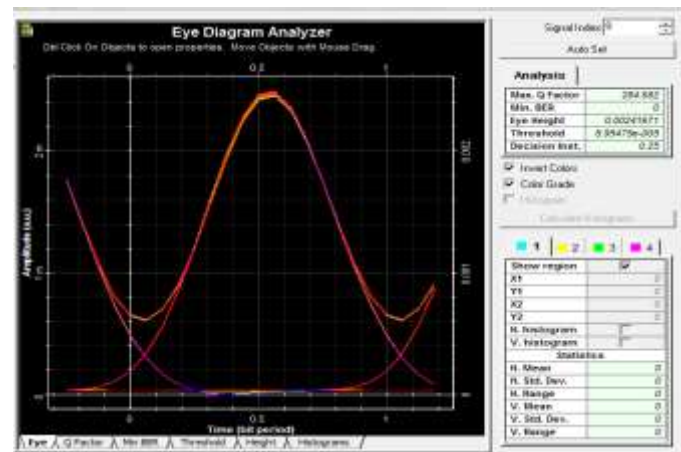

Figure 10. Eye diagram analyzer for signal quality through APD receiver at fiber length (500 km) with scattering section dispersion of 100 m

Figure 11 shows the max Q Factor variations versus scattering section dispersion variations for various data rates. The max Q factor is 279.5, 165, 106, 76, 15.39 at 10 Gb/s, 40 Gb/s, 100 Gb/s, 160 Gb/s, 250 Gb/s respectively at 10 m scattering section dispersion. The max Q factor is 282.5, 168, 109, 78, 17.22 at 10 Gb/s, 40 Gb/s, 100 Gb/s, 160 Gb/s, 250 Gb/s respectively at 50 m scattering section dispersion. While the max Q factor is 284.65, 171, 112, 80, 19.87 at 10 Gb/s, 40 Gb/s, 100 Gb/s, 160 Gb/s, 250 Gb/s respectively at 100 m scattering section dispersion. The max Q factor is 287, 174, 115, 82, 21.2 at 10 Gb/s, 40 Gb/s, 100 Gb/s, 160 Gb/s, 250 Gb/s respectively at 150 m scattering section dispersion. Moreover the max Q factor is 290, 177, 118, 84, 23.7 at 10 Gb/s, 40 Gb/s, 100 Gb/s, 160 Gb/s, 250 Gb/s respectively at 200 m scattering section dispersion. The max Q factor is 292.85, 180, 121, 87, 25.767 at 10 Gb/s, 40 Gb/s, 100 Gb/s, 160 Gb/s, 250 Gb/s respectively at 250 m scattering section dispersion. The results emphasized that the higher the scattering section dispersion the high the max Q factor.

Figure 12 demonstrates the electrical signal power after APD receiver variations versus scattering section dispersion variations for various data rates. The electrical power is 2.356  $\mu$ W, 1.5  $\mu$ W, 1.365  $\mu$ W, 1.186  $\mu$ W, 1  $\mu$ W at 10 Gb/s, 40 Gb/s, 100 Gb/s, 160 Gb/s, 250 Gb/s respectively at 10 m scattering section dispersion. The electrical power is 2.354  $\mu$ W, 1.427  $\mu$ W, 1.341  $\mu$ W, 1.1  $\mu$ W, 0.965  $\mu$ W at 10 Gb/s, 40 Gb/s, 100 Gb/s, 160 Gb/s, 250 Gb/s respectively at 50 m scattering section dispersion. While the electrical power is 2.352  $\mu$ W, 1.367  $\mu$ W, 1.322  $\mu$ W, 1.0765  $\mu$ W, 0.654  $\mu$ W at 10 Gb/s, 40 Gb/s, 100 Gb/s, 160 Gb/s, 250 Gb/s respectively at 100 m scattering section dispersion. The electrical power is 2.35  $\mu$ W, 1.315  $\mu$ W, 1.297  $\mu$ W, 1.0113  $\mu$ W, 0.527  $\mu$ W at 10 Gb/s, 40 Gb/s, 100 Gb/s, 160 Gb/s, 250 Gb/s respectively at 150 m scattering section dispersion. Moreover the electrical power is 2.348  $\mu$ W, 1.286  $\mu$ W, 1.278167  $\mu$ W, 0.956583  $\mu$ W,

0.354  $\mu$ W at 10 Gb/s, 40 Gb/s, 100 Gb/s, 160 Gb/s, 250 Gb/s respectively at 200 m scattering section dispersion. The electrical power is 2.346  $\mu$ W, 1.282  $\mu$ W, 1.256667  $\mu$ W, 0.901833  $\mu$ W, 0.181  $\mu$ W at 10 Gb/s, 40 Gb/s, 100 Gb/s, 160 Gb/s, 250 Gb/s respectively at 250 m scattering section dispersion. The results emphasized that the higher the scattering section dispersion the slightly lower the electrical signal power at APD receiver.

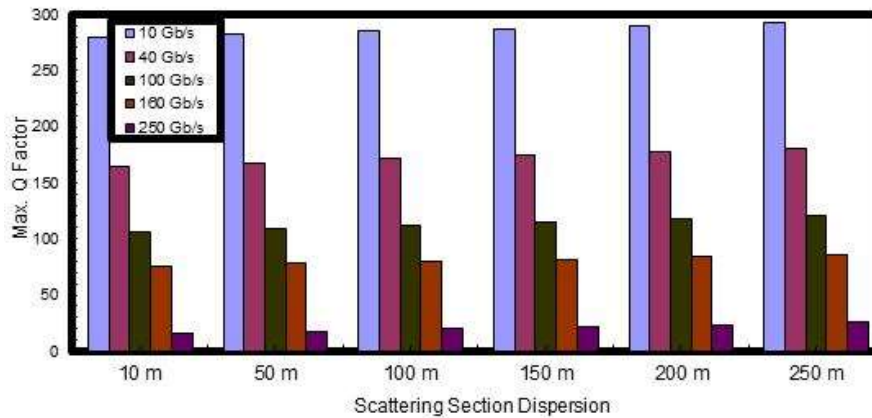

Figure 11. Max Q Factor variations versus scattering section dispersion variations for various data rates

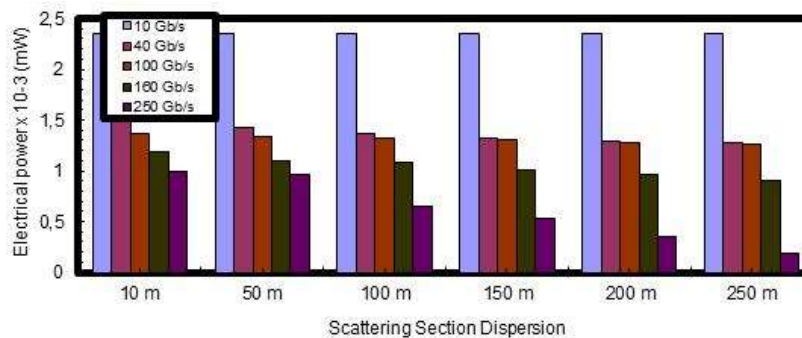

Figure 12. Electrical signal power after APD receiver variations versus scattering section dispersion variations for various data rates

#### 4. CONCLUSION

The fixed scattering section length with variable scattering section dispersion have been simulated based optical fibers for polarization mode dispersion penalties at high data rates. The max Q factor, electrical power variations for various scattering section dispersion and data transmission rates have been clarified. The higher the scattering section dispersion the slightly lower the electrical signal power at APD receiver. It is emphasized that the higher the scattering section dispersion the high the max Q factor can be achieved. The max signal power/min noise power against time has been simulated after fiber length of 500 km with various scattering section dispersion. The higher the scattering section dispersion, the lower max signal power. So it is recommended to operate at 10 m scattering section dispersion with transmission rate of 40 Gbps.

#### REFERENCES

- [1] J. Witzens, *et al.*, "Design of Transmission Line Driven Slot Waveguide Mach-Zehnder Interferometers and Application to Analog Optical Links," *Optics Express.*, vol. 18, no. 16, pp. 1603-1628, 2010.
- [2] IS Amiri, *et al.*, "Pump Laser Automatic Signal Control for Erbium-Doped Fiber Amplifier Gain, Noise Figure, and Output Spectral Power," *Journal of Optical Communications*, Published Online: 17 Dec. 2019, <https://doi.org/10.1515/joc-2019-0203>.

- [3] A. Chandra, *et al.*, “Unified BER and Optimum Threshold Analysis of Binary Modulations in Simple and Cascaded Rayleigh Fading Channels With Switched Combining,” *International Journal of Communication Systems*, vol. 24, no. 2, pp. 153-167, 2011.
- [4] Q. TAO, *et al.*, “Optical Switch Based on Cascaded SOI Nonlinear Directional Coupler,” *Optica Applicata*, vol. 41, no. 3, pp. 669-678, 2011.
- [5] T. Kawanishi, *et al.*, “High Speed Control of Lightwave Amplitude, Phase, and Frequency by use of Electrooptic Effect,” *IEEE Journal of Selected Topics in Quantum Electronics*, vol. 13, no. 1, pp. 79-91, 2007.
- [6] H. V. Pham, *et al.*, “Travelling Wave Electrooptic Modulators With Arbitrary Frequency Response Utilising Non Periodic Polarization Reversal,” *Electronics Letters*, vol. 43, no. 24, pp. 1379-1381, 2007.
- [7] William B. Bridges, James H. Schaffner, “Distortion in Linearized Electrooptic Modulators,” *IEEE Transactions on Microwave Theory and Techniques*, vol. 43, no. 9, 1995.
- [8] Ahmed Nabih Zaki Rashed, Mohammed Salah F. Tabbour “Suitable Optical Fiber Communication Channel for Optical Nonlinearity Signal Processing in High Optical Data Rate Systems” *Wireless Personal Communications Journal*, Springer Publisher, Published online 24 May 2017, vol. 97, no. 1, pp. 397-416, 2017.
- [9] Ahmed Nabih Zaki Rashed, *et al.*, “Optimum Flat Gain With Optical Amplification Technique Based on Both Gain Flattening Filters and Fiber Bragg Grating Methods,” *Journal of Nanoelectronics and Optoelectronics*, vol. 13, no. 5, pp. 665-676, 2018.
- [10] Ahmed Nabih Zaki Rashed, Mohammed Salah F. Tabbour “The Trade Off Between Different Modulation Schemes for Maximum Long Reach High Data Transmission Capacity Optical Orthogonal Frequency Division Multiplexing (OOFDM)” *Wireless Personal Communications Journal*, Springer Publisher, Published online 14 May 2018, <https://doi.org/10.1007/s11277-018-5690-9>, vol. 101, no. 1, pp. 325-337, 2018.
- [11] S. Praveen Chakkravarthy, *et al.*, “Ultra high transmission capacity based on optical first order soliton propagation systems,” *Results in Physics*, vol. 12, pp. 512-513, 2019.
- [12] H. V. Pham, and Y. Okamura, “Electrooptic Modulators with Controlled Frequency Responses by Using Nonperiodically Polarization Reversed Structure,” *Journal of Advances in Optoelectronics*, vol. 8, no. 1, pp. 1-8, 2008.
- [13] Min Chen, *et al.*, “Advances in Multimedia Communications,” *International Journal of Communication Systems*, vol. 24, no. 10, pp. 1243-1245, 2011.
- [14] A. Maksymiuk, and J. Siuzdak, “Modeling of Low Frequency Modal Noise Induced by Multimode Couplers in Cascade Connections,” *Optica Applicata*, vol. 41, no. 3, pp. 649-660, 2011.
- [15] F. T. Sheehy, *et al.*, “94 GHz Antenna-coupled LiNbO<sub>3</sub> Electrooptic Modulators,” *IEEE Photonics Technology Letters*, vol. 5, pp 307-310, 1993.
- [16] Ahmed Nabih Zaki Rashed, *et al.*, “The switching of optoelectronics to full optical computing operations based on nonlinear metamaterials,” *Results in Physics*, Vol. 13, Article 102152, June 2019, <https://doi.org/10.1016/j.rinp.2019.02.088>.
- [17] IS Amiri, *et al.*, “The Engagement of Hybrid Ultra High Space Division Multiplexing with Maximum Time Division Multiplexing Techniques for High-Speed Single-Mode Fiber Cable Systems,” *Journal of Optical Communications*, Published Online: 19 Oct. 2019, <https://doi.org/10.1515/joc-2019-0205>.
- [18] IS Amiri, *et al.*, “Polar Polarization Mode and Average Radical Flux Intensity Measurements Based on All Optical Spatial Communication Systems,” *Journal of Optical Communications*, Published Online: 19 Oct. 2019, <https://doi.org/10.1515/joc-2019-0159>.
- [19] L.M. Johnson, H. V. Roussell, “Reduction of Intermodulation distortion in Interferometric Optical Modulators,” *Optics Letters*, vol. 13, no. 10, 1988.
- [20] M. V. Raghavendra, P. H. Prasad, “Estimation of Optical Link Length for Multi Haul Applications,” *International Journal of Engineering Science and Technology*, vol. 2, no.6, pp. 1485-1491, 2010.
- [21] Ahmed Nabih Zaki Rashed, *et al.*, “Rapid Progress of A Thermal Arrayed Waveguide Grating Module for Dense Wavelength Division Multiplexing Applications,” *International Journal of Advanced Networks and Applications*, vol. 3, no. 2, pp. 1044-1052, 2011.
- [22] S. Sivaranjani, *et al.*, “Performance Evaluation of Bidirectional Wavelength Division Multiple Access Broadband Optical Passive Elastic Networks Operation Efficiency,” *Journal of Optical Communications*, Published Online: 24 Oct. 2019, <https://doi.org/10.1515/joc-2019-0175>.
- [23] IS Amiri, *et al.*, “High-Speed Transmission Circuits Signaling in Optical Communication Systems,” *Journal of Optical Communications*, Published Online: 9 Nov. 2019, <https://doi.org/10.1515/joc-2019-0197>.
- [24] IS Amiri, *et al.*, “Technical Specifications of the Submarine Fiber Optic Channel Bandwidth/Capacity in Optical Fiber Transmission Systems,” *Journal of Optical Communications*, Published Online: 9 Nov. 2019, <https://doi.org/10.1515/joc-2019-0226>.
- [25] M. Ghanbarisabagh, *et al.*, “Cyclic Prefix Reduction for 20.48 Gb/s Direct Detection Optical OFDM Transmission over 2560 km of SSMF,” *International Journal of Communication Systems*, Vol. 24, No. 11, pp. 1407-1417, 2011.
- [26] H. Hu, *et al.*, “Lithium Niobate Ridge Waveguides Fabricated by Wet Etching,” *IEEE Photonics Technology Letters*, vol. 19, no. 6, pp. 417-419, 2007.
- [27] A. Kozanecka, *et al.*, “Electro Optic Activity of an Azopolymer Achieved Via Poling With the Aid of Silicon Nitride Insulating Layer,” *Optica Applicata*, vol. 41, no. 3, pp. 777-785, 2011.
- [28] Steven K. Korotky, René M. De Ridder, “Dual Parallel Modulation Schemes for Low-Distortion Analog Optical Transmission,” *IEEE Journal on Selected Areas in Communications*, vol. 8, no. 7, 1990.

- [29] J. F. Lam and G. L. Tangonan, "Optical modulation system with enhanced linearization properties," *IEEE Photon. Technol. Lett.*, Vol. 3, No. 12, pp. 1102-1104, 1991.
- [30] IS Amiri, *et al.*, "Influence of device to device interconnection elements on the system behavior and stability," *Indonesian Journal of Electrical Engineering and Computer Science*, vol. 18, no. 2, pp. 843-847, 2020, DOI: 10.11591/ijeecs.v18.i2.pp843-847.
- [31] Mahmoud M. A. Eid, *et al.*, "Dental lasers applications in visible wavelength operational band," *Indonesian Journal of Electrical Engineering and Computer Science*, vol. 18, no. 2, pp. 890-895, 2020, DOI: 10.11591/ijeecs.v18.i2.pp890-895.
- [32] IS Amiri, *et al.*, "Comparative Simulation Study of Multi Stage Hybrid All Optical Fiber Amplifiers in Optical Communications," *Journal of Optical Communications*, vol. 0, no. 0, Published Online: 4 Feb. 2020, <https://doi.org/10.1515/joc-2019-0132>.
- [33] IS Amiri, *et al.*, "Optical Communication Transmission Systems Improvement Based on Chromatic and Polarization Mode Dispersion Compensation Simulation Management," Published online 23 November 2019, *Optik Journal*, Vol. 207, article163853, April 2020, <https://doi.org/10.1016/j.ijleo.2019.163853>.
- [34] D. Samanta, *et al.*, "Distributed Feedback Laser (DFB) for Signal Power Amplitude Level Improvement in Long Spectral Band," *Journal of Optical Communications*, Vol. 0, Issue 0, Published Online: 2 April 2020, <https://doi.org/10.1515/joc-2019-0252>.
- [35] IS Amiri, *et al.*, "Analytical Model Analysis of Reflection/Transmission Characteristics of Long-Period Fiber Bragg Grating (LPFBG) by Using Coupled Mode Theory," *Journal of Optical Communications*, Vol. 0, Issue 0, Published Online: 2 April 2020, <https://doi.org/10.1515/joc-2019-0187>.