

Transcription of σ^{54} -dependent but not σ^{28} -dependent flagellar genes in *Campylobacter jejuni* is associated with formation of the flagellar secretory apparatus

David R. Hendrixson¹ and Victor J. DiRita^{1,2*}

¹Unit for Laboratory Animal Medicine and

²Department of Microbiology and Immunology, University of Michigan Medical School, 5641 Medical Science II, Box 0620, Ann Arbor, MI 48109-0620, USA.

Summary

We performed a genetic analysis of flagellar regulation in *Campylobacter jejuni*, from which we elucidated key portions of the flagellar transcriptional cascade in this bacterium. For this study, we developed a reporter gene system for *C. jejuni* involving *astA*, encoding arylsulphatase, and placed *astA* under control of the σ^{54} -regulated *flgDE2* promoter in *C. jejuni* strain 81-176. The *astA* reporter fusion combined with transposon mutagenesis allowed us to identify genes in which insertions abolished *flgDE2* expression; genes identified were on both the chromosome and the plasmid pVir. Included among the chromosomal genes were genes encoding a putative sensor kinase and the σ^{54} -dependent transcriptional activator, FlgR. In addition, we identified specific flagellar genes, including *flhA*, *flhB*, *fliP*, *fliR* and *flhF*, that are also required for transcription of *flgDE2* and are presumably at the beginning of the *C. jejuni* flagellar transcriptional cascade. Deletion of any of these genes reduced transcription of both *flgDE2* and another σ^{54} -dependent flagellar gene, *flaB*, encoding a minor flagellin. Transcription of the σ^{28} -dependent gene *flaA*, encoding the major flagellin, was largely unaffected in the mutants. Further examination of *flaA* transcription revealed significant σ^{28} -independent transcription and only weak repressive activity of the putative anti- σ^{28} factor FlgM. Our study suggests that σ^{54} -dependent transcription of flagellar genes in *C. jejuni* is linked to the formation of the flagellar secretory apparatus. A key difference in the *C. jejuni* flagellar transcriptional cascade compared with other bacteria that use σ^{28} for transcription of flagellar genes is that a mechanism to repress significantly σ^{28} -

dependent transcription of *flaA* in flagellar assembly mutants is absent in *C. jejuni*.

Introduction

Construction of the flagellar organelle of a bacterium is an exquisitely ordered process involving the temporal expression of approximately 45 genes. Genes encoding structural subunits of the flagellum are transcribed in the order in which they are incorporated in the flagellum, starting from the cell envelope and extending extracellularly to the tip of the flagellum (Macnab, 1996). In the classic paradigm of the flagellar transcriptional cascade in *Salmonella* species, flagellar genes can be divided into three classes based on their order of transcription (Kutsukake *et al.*, 1990; Karlinsey *et al.*, 2000). Briefly, class 1 genes include genes for the major transcriptional regulators *flhDC* that are required for expression of the remaining flagellar genes. Class 2 genes include genes encoding the flagellar secretory apparatus, the flagellar basal body and hook structures and *fliA*, encoding the alternative σ factor, σ^{28} . Class 3 genes, transcription of which requires σ^{28} , include genes encoding the flagellin subunits that are incorporated last into the growing flagellum. Feedback loops are incorporated into the regulatory system to ensure that the flagellar genes are transcribed in appropriate order. For example, flagellin subunits are not transcribed until a complete basal body and hook structure is formed. To accomplish this, a class 2 flagellar gene product, FlgM, represses σ^{28} activity, thereby preventing transcription of the flagellin genes (Gillen and Hughes, 1991). After a complete basal body and hook are formed, the FlgM anti- σ factor is secreted through this nascent structure to the extracellular environment, thereby reducing intracellular FlgM concentrations and relieving repression of σ^{28} , which allows for transcription of the class 3 genes including the flagellin genes (Hughes *et al.*, 1993).

This flagellar transcriptional cascade is generally conserved in many different bacteria, including *Helicobacter pylori*, *Vibrio cholerae* and *Pseudomonas aeruginosa*, although these bacteria use both σ^{54} and σ^{28} to control transcription of flagellar genes (Totten *et al.*, 1990; Starnbach and Lory, 1992; Klose and Mekalanos, 1998a,b; Spohn and Scarlato, 1999; Colland *et al.*, 2001; Prouty *et al.*, 2001; Josenhans *et al.*, 2002; Jyot *et al.*, 2002). In

Accepted 18 July, 2003. *For correspondence at the Department of Microbiology and Immunology. E-mail vdirita@umich.edu; Tel. (+1) 734 936 3804; Fax (+1) 734 764 3562.

these organisms, both σ^{28} - and σ^{54} -dependent transcription of flagellar genes is incorporated into the flagellar transcriptional cascade to achieve proper temporal regulation of the flagellar genes. For instance, σ^{54} in conjunction with σ^{54} -dependent transcriptional activators has been proposed or shown to be involved in transcription of many of the class 2 genes, whereas σ^{28} is involved in transcription of the class 3 genes including those encoding the flagellins (Starnbach and Lory, 1992; Arora *et al.*, 1998; Spohn and Scarlato, 1999; Prouty *et al.*, 2001; Jyot *et al.*, 2002). *V. cholerae* presents an alternative to this regulatory cascade as σ^{54} is required for transcription of the major flagellin, whereas σ^{28} is involved in the transcription of the remaining minor flagellins (Prouty *et al.*, 2001). In *Caulobacter crescentus*, regulation of flagellar genes only involves σ^{54} , as σ^{28} is apparently absent in the bacterium (Wu and Newton, 1997). Activation of σ^{54} -dependent transcription of the flagellar hook, basal body and flagellin genes in *C. crescentus* is linked to the formation of the flagellar secretory apparatus and the MS ring-switch complex (Ramakrishnan *et al.*, 1994; Wu and Newton, 1997).

Campylobacter jejuni, a common commensal organism of the gastrointestinal tracts of many birds and a frequent cause of gastroenteritis in humans, elaborates a single flagellum at one or both poles of the bacterium. Two flagellin genes, *flaA* and *flaB*, are present in tandem on the chromosome of *C. jejuni* and are approximately 95% identical to each other (Nuijten *et al.*, 1990). Both FlaA and FlaB appear to be incorporated into the flagellum. Transcription of flagellar genes in *C. jejuni* involves both σ^{54} and σ^{28} ; the former is required for transcription of genes encoding a putative hook protein, hook-associated protein and the minor flagellin FlaB, and the latter is involved in transcribing the gene encoding the major flagellin FlaA (Hendrixson *et al.*, 2001). Even though either the flagellum or motility is required for colonization (Nachamkin *et al.*, 1993; Wassenaar *et al.*, 1993), disease in humans (Black *et al.*, 1988) and *in vitro* invasion (Wassenaar *et al.*, 1991; Grant *et al.*, 1993; Yao *et al.*, 1994), little is known about the flagellar transcriptional cascade in *C. jejuni*. An NtrC homologue, FlgR, is required for flagella biogenesis and motility (Jagannathan *et al.*, 2001), but the specific role of this protein in the flagellar transcriptional cascade in *C. jejuni* has yet to be determined.

In this study, we performed experiments to elucidate the flagellar transcriptional cascade in *C. jejuni*. To do so, we adapted the *astA* gene, encoding the enzyme arylsulphatase, as a new reporter gene for *C. jejuni* that allowed us to monitor transcription of flagellar genes. We performed transposon mutagenesis with *C. jejuni* harbouring a transcriptional fusion of the σ^{54} -dependent flagellar operon *flgDE2* to *astA* and identified 10 chromosomal genes required for transcription of σ^{54} -dependent flagellar

genes, including genes encoding proteins at the beginning of the flagellar transcriptional cascade in other organisms, a gene encoding a putative sensor kinase and *flgR*, encoding the NtrC homologue noted above (Jagannathan *et al.*, 2001). All the mutants were deficient for σ^{54} -dependent transcription of flagellar genes but, unlike what has been described for other flagellar systems, these mutants still expressed the major flagellin gene *flaA*, which uses σ^{28} for transcription. Further analysis revealed a homologue of FlgM in *C. jejuni* that acts to inhibit σ^{28} activity in other flagellar systems. In contrast, the FlgM homologue in *C. jejuni* appears to be only weakly active as an anti- σ factor for σ^{28} -dependent transcription of *flaA*. Thus, our study reveals unique features of the *C. jejuni* flagellar transcriptional cascade compared with other bacteria.

Results

Development of a reporter system for analysis of flgDE2 gene expression

We wanted to analyse control of genes expressed relatively late in the hierarchy of flagellar assembly, and also to focus on those controlled by σ^{54} , which we and others have shown to be important in flagellar gene regulation in *C. jejuni* (Hendrixson *et al.*, 2001; Jagannathan *et al.*, 2001). We considered that this approach would lead us to identify potential regulators of σ^{54} activity necessary for both flagellar development and other aspects of *C. jejuni* pathogenicity, given that flagellar motility or flagella *per se* appear to be important for host association by this organism (Black *et al.*, 1988; Wassenaar *et al.*, 1991; 1993; Grant *et al.*, 1993; Nachamkin *et al.*, 1993; Yao *et al.*, 1994). We anticipated that our approach would identify two classes of genes: one encoding transcriptional regulators that function with σ^{54} and another encoding flagellar proteins whose proper expression might be required in order for late genes to be expressed.

We chose to focus on an operon at *Cj0042–Cj0043*, which we identified previously as regulated by σ^{54} and in which *Cj0042* (*flgD*) had been shown to be essential for wild-type motility (Hendrixson *et al.*, 2001). FlgD is predicted to be a hook assembly protein, presumably required later in the assembly pathway (Parkhill *et al.*, 2000). *Cj0043* is annotated as *flgE*, encoding a probable hook protein (Parkhill *et al.*, 2000), but deletion of this gene had no effect on motility or flagellar assembly (Fig. 1A, B and D). Another gene, *Cj1729c*, is annotated as *flgE2* (Parkhill *et al.*, 2000), but another group has already shown it to encode a hook protein and termed the gene *flgE* (Lüneberg *et al.*, 1998). In contrast to deletion of *Cj0043*, disruption of *Cj1729c* had a dramatic effect on motility and flagellar assembly (Fig. 1A–C). We propose to reverse the annotation of *Cj1729c* and *Cj0043* and will

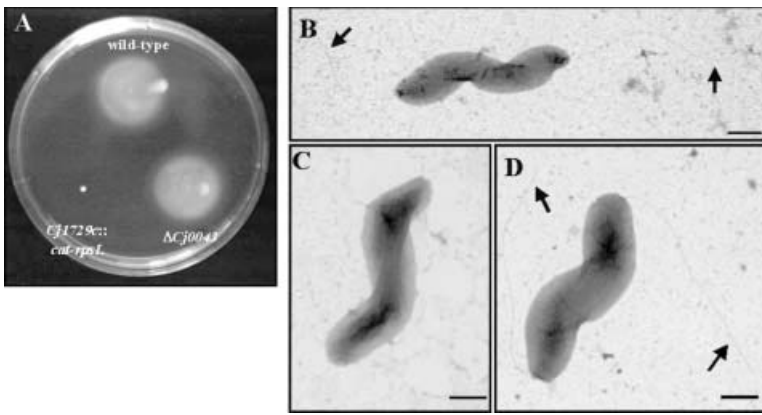

Fig. 1. Analysis of *Cj0043* and *Cj1729c* in motility and flagellar biosynthesis.

A. Motility phenotypes of DRH212 (wild-type 81-176 Sm^R), DRH963 (81-176 *Cj1729c::cat-rpsL*) and DRH619 (81-176 Δ *Cj0043*) in MH motility media.

B–D. Electron micrographs of *C. jejuni* negatively stained with 1% uranyl acetate at 13 500 \times magnification. Bar = 0.5 μ m. B. DRH212 (81-176 Sm^R). C. DRH963 (81-176 *Cj1729c::cat-rpsL*). D. DRH619 (81-176 Δ *Cj0043*). Arrows indicate flagella.

refer to the former as *flgE* and the latter as *flgE2*; this is also in keeping with the nomenclature of Lüneberg *et al.* (1998). The *flgDE2* operon met our criteria for further study in that we have already determined experimentally that it is regulated by σ^{54} and that *flgD* encodes a flagellar protein predicted to function late in flagellar assembly. Although the *flgE* gene (*Cj1729c*) does harbour a putative σ^{54} binding site upstream, we have not yet experimentally proved its dependence on σ^{54} for transcription. Given these considerations, we chose to use *flgDE2* for further analysis.

To study σ^{54} -regulated *flgDE2* transcription, we adapted as a reporter the *C. jejuni* gene *astA* (Yao and Guerry, 1996), which encodes arylsulphatase. This enzyme cleaves sulphate groups from aryl compounds, and its activity can be detected by the addition of the chromogenic substrate, 5-bromo-4-chloro-3-indolyl sulphate (XS) to MH agar, resulting in a blue colony phenotype (Yao and Guerry, 1996). In addition, a quantitative assay allows monitoring levels of the enzyme in whole-cell lysates spectrophotometrically by measuring the release of nitrophenol from nitrophenylsulphate (Henderson and Milazzo, 1979), similar to the assay traditionally used to quantify β -galactosidase activity with the substrate *o*-nitrophenylgalactoside.

We deleted *astA* from *C. jejuni* strain 81-176 Sm^R (DRH212) and 81-176 Δ *rpoN* (DRH321; Hendrixson *et al.*, 2001), creating DRH461 and DRH453 respectively. DRH461 and DRH453 showed nearly undetectable arylsulphatase activity compared with the parental strains (Fig. 2). To construct a *flgDE2::astA* operon fusion, we isolated an insertion of the *nemo* transposon (which contains a promoterless *astA* gene linked to *aphA-3* encoding kanamycin resistance; see *Experimental procedures*) in pDRH351 harbouring *flgDE2*, thereby creating pDRH532. The *nemo* insertion in this plasmid is located 515 bp downstream of the *flgE2* start codon, creating a functional *flgDE2::astA* transcriptional fusion. The plasmid pDRH532 was then electroporated into DRH461 and DRH453, and

kanamycin-resistant transformants were selected that resulted from the replacement of *flgDE2* with *flgDE2::nemo* in the chromosome, creating DRH533 (81-176 Δ *astA flgDE2::nemo*) and DRH536 (81-176 Δ *rpoN* Δ *astA flgDE2::nemo*). *C. jejuni* 81-176 Δ *astA* containing the reporter gene fusion appeared as light blue colonies on MH agar containing the chromogenic substrate XS, whereas the Δ *rpoN* Δ *astA* derivative appeared as white colonies (data not shown). Arylsulphatase assays revealed that *astA* transcription from *flgDE2::nemo* was almost 100-fold higher in the 81-176 Δ *astA* background than in the Δ *rpoN* Δ *astA* mutant (Fig. 2). Complementation of the Δ *rpoN* Δ *astA* mutant with *rpoN* expressed from a chloramphenicol acetyltransferase (*cat*) promoter on

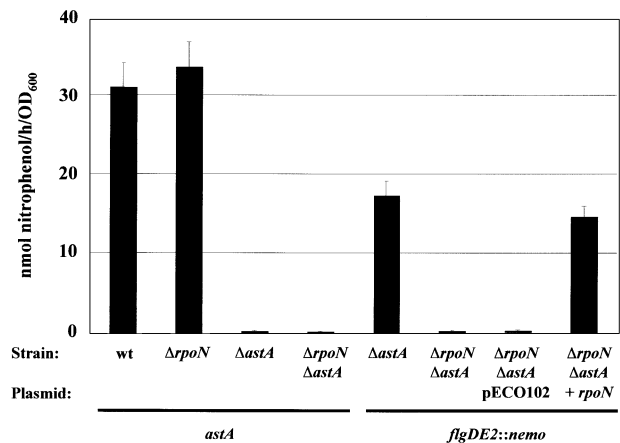

Fig. 2. Arylsulphatase assay of reporter strains containing *flgDE2::nemo* and establishment of *astA* as a reporter gene for *C. jejuni*. The first four bars represent arylsulphatase activity originating from the *astA* locus of each strain, and the last four bars represent arylsulphatase activity originating from *flgDE2::nemo* in each strain. Each strain was tested in triplicate, and the values reported represent the average arylsulphatase activity \pm standard deviation from a representative assay. One arylsulphatase unit equals the amount of arylsulphatase necessary to generate 1 nmol of nitrophenol h⁻¹ per OD₆₀₀ of 1. Strains used include DRH212, DRH321, DRH461, DRH453, DRH533, DRH536, DRH536/pECO102 and DRH536/pECO105.

pECO102 (Wiesner *et al.*, 2003) almost completely restored expression of *flgDE2::astA* to wild-type levels (Fig. 2). These results reflect control by σ^{54} over transcription of *flgDE2* as shown before (Hendrixson *et al.*, 2001) and demonstrate that *astA* can be used as a transcriptional reporter gene in *C. jejuni*.

Identification of genes required for transcription of *flgDE2::astA* by transposon mutagenesis

To identify genes required for transcription of *flgDE2::astA*, we purified chromosomal DNA from strain DRH533 (81-176 $\Delta astA flgDE2::nemo$) and subjected it to *in vitro* transposition with the *picard* transposon from pEnterprise2. Thirty-nine individual transposition reactions were performed, and the transposed chromosomal DNA was then transformed into DRH533 to obtain approximately 14 000 individual transposon mutants. The transposon mutants were recovered on MH agar containing chloramphenicol and the chromogenic substrate for AstA, XS. Eighty-three mutants were identified that appeared as white colonies indicating an AstA⁻ phenotype.

DNA from each mutant was purified and sequenced to identify the location of *picard* in each derivative. Ten mutants contained transposon insertions between the *flgDE2* promoter and the end of *astA*, resulting in destruction of the transcriptional reporter; these mutants were investigated no further. Fifty mutants contained *picard* insertions in other chromosomal loci in *C. jejuni* (Table 1). Multiple insertions were identified in *rpoN*, *flgR* (*Cj1024c*) and *Cj0793*. *flgR* is predicted to encode an NtrC homologue σ^{54} -dependent transcriptional activator required for motility and flagellar biosynthesis (Jagannathan *et al.*, 2001). *Cj0793* is predicted to encode a probable signal transduction histidine kinase homologous to many sensor kinases of bacterial two-component regulatory systems (Stock *et al.*, 2000). Considering the putative functions of FlgR and Cj0793, these proteins may represent a two-component regulatory system controlling expression of σ^{54} -dependent flagellar genes. Owing to our analysis of *Cj0793* described below, we propose to name this gene *flgS* and will use this designation for the remainder of the study.

Approximately half the chromosomal insertions were located in *flhA*, *flhB*, *fliP* or *fliR*, which encode proteins implicated in forming the apparatus required for secretion of the flagellar hook, basal body and flagellin proteins during formation of the flagellum (Minamino and Macnab, 1999). Seven mutants contained *picard* in *flhF*, which encodes a putative GTP-binding protein required for proper flagellar biosynthesis in a subset of bacteria including *Bacillus subtilis*, *Vibrio parahaemolyticus* and *Pseudomonas putida* (Carpenter *et al.*, 1992; Kim and McCarter, 2000; Pandza *et al.*, 2000). One mutant con-

Table 1. Location of *picard* in *C. jejuni* mutants defective for *astA* transcription from *flgDE2::nemo*.

| Gene ^{abc} | Identification/proposed function ^a |
|---------------------------------|--|
| Chromosomal loci | |
| <i>rpoN</i> (5) | RNA polymerase σ^{54} subunit |
| <i>flgR</i> (3) | Probable signal transduction regulatory protein |
| <i>Cj0793</i> (3) | Probable signal transduction histidine kinase |
| <i>flhA</i> (17) | Probable flagellar biosynthesis protein |
| <i>flhB</i> (2) | Probable flagellar biosynthesis protein |
| <i>flhF</i> (7) | Flagellar biosynthesis protein |
| <i>fliP</i> (5) | Probable flagellar biosynthesis protein |
| <i>fliR</i> (5) | Probable flagellar biosynthesis protein |
| <i>Cj0883c</i> ^d (2) | Unknown/no identity |
| <i>Cj1341</i> | <i>maf7</i> ; member of paralogous gene family implicated in phase variation of flagella |
| pVir loci | |
| <i>Cjp01</i> (4) | <i>virB8</i> ; type IV secretion/competence protein |
| <i>Cjp03</i> | <i>virB10</i> ; type IV secretion/competence protein |
| <i>Cjp06</i> (2) | <i>H. pylori virD4</i> homologue |
| <i>Cjp07</i> | Unknown |
| <i>Cjp10</i> | <i>H. pylori</i> JHP0937 homologue |
| <i>Cjp11</i> (2) | <i>topA</i> ; <i>H. pylori</i> topoisomerase 1 homologue |
| <i>Cjp13</i> | <i>ssb</i> ; single-stranded DNA binding protein |
| <i>Cjp22</i> | Unknown |
| <i>Cjp28</i> (2) | <i>repA</i> pseudogene; homologue of plasmid replication proteins |
| <i>Cjp35</i> | Unknown |
| <i>Cjp39</i> | Unknown |
| <i>Cjp44</i> | Unknown |
| <i>Cjp45</i> | Unknown |
| <i>Cjp47</i> | Unknown |
| <i>Cjp49</i> | Homologue of <i>H. pylori</i> HP0996 and JHP0942 |
| <i>Cjp51</i> (2) | Unknown |

a. Gene designation and proposed function are based on the annotated genome sequence from *C. jejuni* NCTC 11168 (Parkhill *et al.*, 2000) and the annotated pVir sequence from *C. jejuni* 81-176 (Bacon *et al.*, 2002).

b. Number indicates number of mutants identified with different *picard* insertions in the respective gene.

c. Each transposon mutant displayed at least a 10-fold reduction in *flgDE2::astA* transcription compared with the wild-type strain as determined by arylsulphatase assays (data not shown).

d. One *picard* insertion is in the coding sequence of *Cj0883c* and another is located 34 bp upstream of the start codon of this gene. *Cj0883c* is immediately upstream of *flhA* (Parkhill *et al.*, 2000); the *flgDE2::astA* transcriptional defect by the *picard* insertions in these mutants may result from polar effects on the transcription of *flhA*.

tained a transposon insertion in *maf7*, which is a member of a family of genes in *C. jejuni* with products that have been implicated in phase variation of flagella (Karlyshev *et al.*, 2002).

We were surprised to identify 23 mutants with *picard* insertions in pVir, a plasmid maintained in *C. jejuni* 81-176 that appears to encode components of a type IV secretion system (Bacon *et al.*, 2000; 2002). These 23 insertions were found scattered around pVir including in genes encoding some of the type IV secretion proteins (such as *virB8* and *virB10*) and numerous unknown genes (Table 1). However, upon purification of the mutant plasmids and transformation into 81-176 $\Delta astA flgDE2::nemo$ (which replaced the wild-type pVir with the mutant plasmids), we found that colonies derived from

each mutant pVir transformation expressed *flgDE2::astA* to either wild-type level or not at all. Hence, the pVir mutants (but not the above chromosomal mutants) could not consistently reproduce defective transcription of *flgDE2::astA*. We note these pVir genes identified here simply in the interest of describing the *picard* mutagenesis findings completely.

Analysis of defined deletion mutants for motility, flagellar biosynthesis and transcription of *flgDE2::astA*

To characterize the role of specific chromosomal genes identified from the screen, we created in frame deletion mutations of *flgR*, *flgS*, *flhA*, *fliP* and *fliR* in 81-176 Sm^R (DRH212) and in 81-176 Δ *astA* (DRH461; the deletion end-points are detailed in Table S1 in *Supplementary material*). In addition, we replaced codons 2–364 of *flhB* with a *cat-rpsL* cassette in 81-176 Sm^R, thereby deleting a large portion of the gene and insertionally inactivating the deletion construct. In 81-176 Δ *astA*, we were able to create an in frame deletion mutant of *flhB*. We could make an in frame deletion of *flhF* in 81-176 Sm^R but not in 81-176 Δ *astA*.

Mutations in *flgR*, *flgS*, *flhA*, *flhB*, *flhF*, *fliP* and *fliR* in 81-176 Sm^R resulted in non-motile phenotypes (Fig. 3), which appeared to result from the inability of these mutants to synthesize flagella as determined by transmission electron microscopy (compare Fig. 4A–E to 81-176 Sm^R in Fig. 1B). Mutants lacking *flgR* and *flhB* also did not produce flagella when analysed by electron microscopy as has been reported previously (data not shown; Jagannathan *et al.*, 2001; Matz *et al.*, 2002). When the Δ *flgR* mutant was complemented with pECO102 containing the *flgR* coding sequence, motility and production of flagella were restored (Fig. 3A; data not shown). We attempted to complement the *flgS*, *flhA*, *flhB*, *flhF* and *fliP* mutants with pECO102 derivatives containing the respective coding

sequences of each gene. However, after multiple conjugation attempts, we were unable to recover transconjugants containing the complementing plasmids, suggesting that overexpression of these genes from pECO102 may be toxic to *C. jejuni*. We also attempted to make a pECO102 derivative containing the *fliR* coding sequence, but were unable to make this plasmid in *Escherichia coli*.

To examine the ability of the mutants to transcribe *astA* from the *flgDE2::nemo* reporter, each deletion mutant in the Δ *astA* background was electroporated with pDRH532 to replace *flgDE2* with *flgDE2::nemo* and assayed for arylsulphatase activity. Deletion of *rpoN*, *flgR* and *flgS* resulted in approximately 100- to 250-fold reductions in transcription of *flgDE2::astA* (Table 2). Complementation of the Δ *rpoN* and Δ *flgR* mutants with plasmid-encoded *rpoN* and *flgR*, respectively, restored transcription of the reporter fusion, verifying the requirement of these genes in the transcription of *flgDE2*. Transcription of *flgDE2::astA* was independent of the only other alternative σ factor, σ^{28} (encoded by *fliA*). Deletion of *flhA*, *flhB*, *fliP* and *fliR* also reduced transcription of *flgDE2::astA* approximately 10- to 60-fold depending on the mutation. These data verify the transposon screen for mutants defective in transcription of *flgDE2::astA*. Although not identified in our transposon mutagenesis screen, we also constructed a deletion of *flgE* (encoding the putative flagellar hook) in 81-176 Δ *astA* *flgDE2::astA* and found that transcription of the reporter was also defective in this mutant, implicating *flgE* in *flgDE2* transcription along with the other flagellar assembly gene products. To analyse *flgE2* transcription in 81-176 Δ *flhF* (DRH1056), we performed reverse transcription polymerase chain reaction (RT-PCR) with primers specific for *flgE2* and detected decreased product, suggesting a role for FlhF in transcription of this gene as well (data not shown).

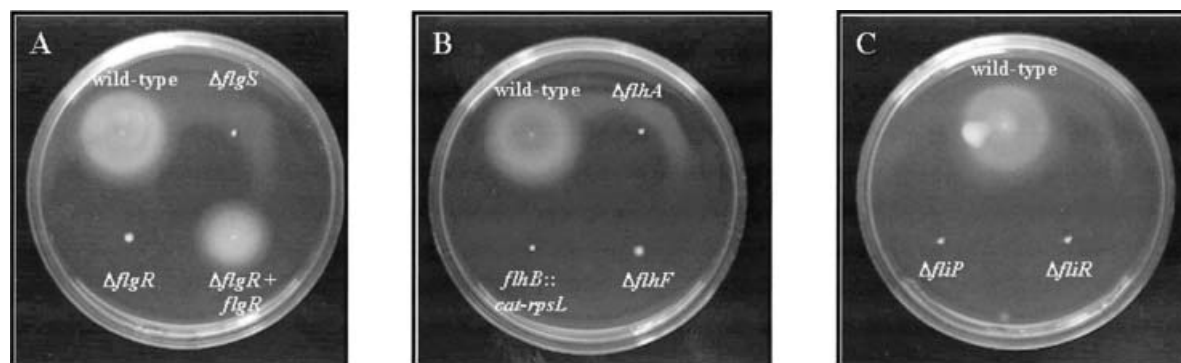

Fig. 3. Motility phenotypes of *C. jejuni* flagellar mutants in MH motility media.

A. DRH212 (wild-type 81-176 Sm^R), DRH460 (81-176 Δ *flgS*), DRH737 (81-176 Δ *flgR*), and DRH737/pDRH818.
 B. DRH212 (wild-type 81-176 Sm^R), DRH946 (81-176 Δ *flhA*), DRH822 (81-176 Δ *flhB::cat-rpsL*), and DRH1056 (81-176 Δ *flhF*).
 C. DRH212 (wild-type 81-176 Sm^R), DRH1065 (81-176 Δ *fliP*) and DRH755 (81-176 Δ *fliR*).

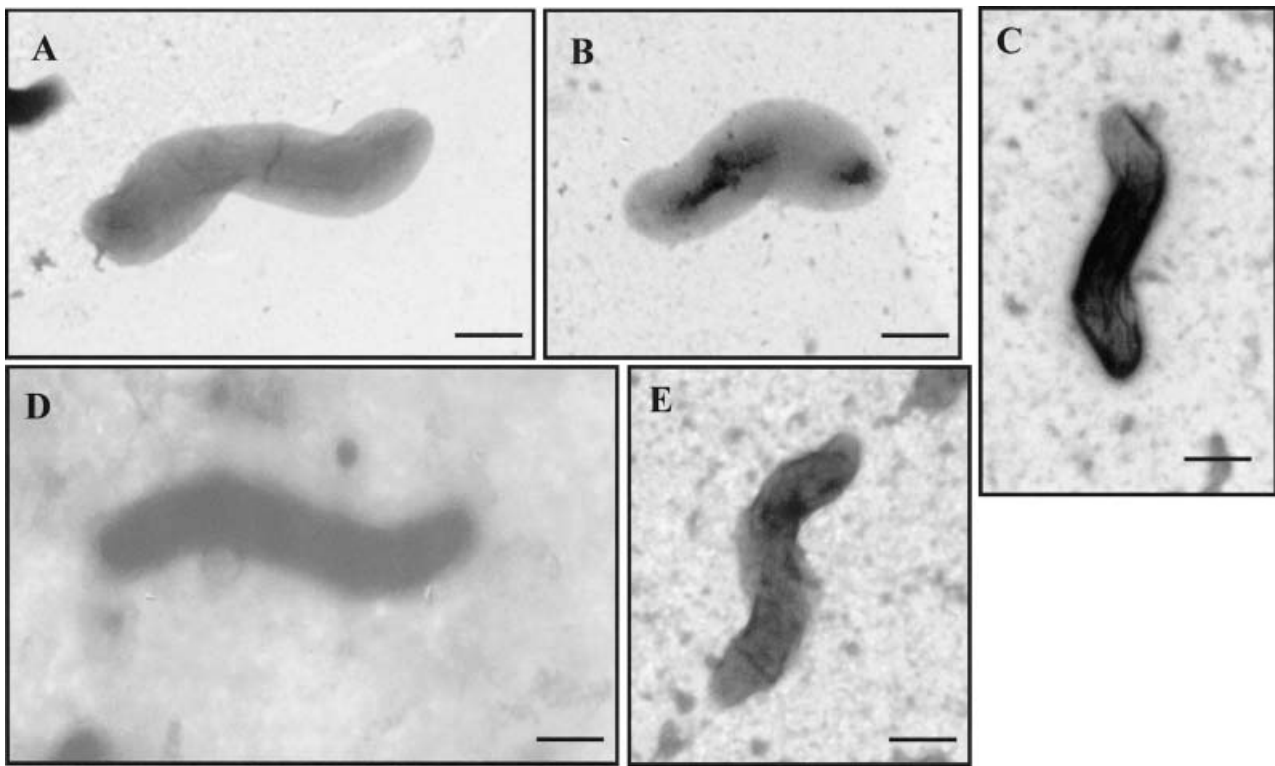

Fig. 4. Electron micrographs of *C. jejuni* flagellar mutants. Bacteria were negatively stained with 1% uranyl acetate. All micrographs are at 13 500 \times magnification. Bar = 0.5 μ m.
 A. DRH460 (81-176 Δ *flgS*).
 B. DRH946 (81-176 Δ *flhA*).
 C. DRH1056 (81-176 Δ *flhF*).
 D. DRH1065 (81-176 Δ *fliP*).
 E. DRH755 (81-176 Δ *fliR*).

Analysis of transcription of *flaB::astA* and *flaA::astA* in defined mutants

Another σ^{54} -dependent flagellar gene in *C. jejuni* is *flaB*, which, in the scheme described for flagellar cascades in other bacteria, is predicted to be a class 3 gene, transcription of which is downstream of genes encoding flagellar hook proteins. To investigate whether the above deletion mutants were defective for transcription of *flaB*, as they were for transcription of the *flgDE2* promoter, a *flaB::astA* reporter gene fusion was made and electroporated into each mutant, replacing *flaB* with the reporter construct. Similar to what we observed for *flgDE2*, transcription of *flaB* was reduced in all the mutants ranging from an approximately 50-fold reduction to over a 1000-fold reduction, depending on the mutation (Table 2). Transcription of *flaB::astA* was restored in the Δ *rpoN* and Δ *flgR* mutants by plasmid complementation. As predicted, σ^{28} was not required for transcription of *flaB::astA*; in fact, we observed a 75% increase in *flaB::astA* transcription in the Δ *fliA* mutant. These data suggest that mutations in the flagellar secretion apparatus and in the putative regula-

tory genes *flgR* and *flgS* have a general negative effect on σ^{54} -dependent transcription of flagellar genes in *C. jejuni*.

In *Salmonella typhimurium*, mutations in the genes encoding proteins that constitute the flagellar secretory apparatus or the flagellar basal body and hook structures, such as *flhA*, *flhB*, *fliP*, *fliR* and *flgE* among others, lead to repression of σ^{28} -dependent transcription of flagellar genes such as the major flagellin (Kutsukake *et al.*, 1990; Hughes *et al.*, 1993). Repression is mediated by the FlgM anti- σ factor, which binds to σ^{28} and prevents the formation of productive σ^{28} -RNA holoenzyme complexes necessary for transcription of σ^{28} -dependent flagellar genes (Ohnishi *et al.*, 1992; Hughes *et al.*, 1993; Chadsey *et al.*, 1998). Upon completion of the hook and basal body element, FlgM is secreted from the bacterium, thus allowing σ^{28} to express σ^{28} -dependent genes.

Our results suggest that a checkpoint control mechanism may exist for σ^{54} -dependent flagellar gene expression in *C. jejuni*, but we also wanted to determine whether, as in *Salmonella* species, blocking flagellar secretion represses σ^{28} -dependent flagellar gene expression in *C.*

Table 2. Arylsulphatase activity of *flgDE2*–, *flaB*– and *flaA*–*astA* transcriptional fusions in *C. jejuni* strain 81-176.^a

| Strain | <i>flgDE2::nemo</i> ^b | <i>flaB::astA</i> ^c | <i>flaA::astA</i> ^d |
|------------------------------------|----------------------------------|--------------------------------|--------------------------------|
| Wild type | 17.29 ± 1.81 | 81.89 ± 5.85 | 87.05 ± 1.50 |
| Δ <i>fliA</i> | 21.87 ± 0.09 | 143.62 ± 4.07 | 42.38 ± 2.11 |
| Δ <i>fliA</i> + vector | ND ^e | ND | 37.67 ± 0.73 |
| Δ <i>fliA</i> + <i>fliA</i> | ND | ND | 338.18 ± 23.47 |
| Δ <i>rpoN</i> | 0.18 ± 0.08 | 0.08 ± 0.03 | 91.59 ± 1.11 |
| Δ <i>rpoN</i> + vector | 0.16 ± 0.10 | 0.09 ± 0.04 | ND |
| Δ <i>rpoN</i> + <i>rpoN</i> | 14.61 ± 1.34 | 70.21 ± 3.19 | ND |
| Δ <i>flgR</i> | 0.07 ± 0.01 | 0.10 ± 0.04 | 91.54 ± 3.78 |
| Δ <i>flgR</i> + vector | 0.07 ± 0.01 | 0.20 ± 0.11 | ND |
| Δ <i>flgR</i> + <i>flgR</i> | 15.92 ± 1.97 | 83.38 ± 6.37 | ND |
| Δ <i>flgS</i> | 0.09 ± 0.04 | 0.15 ± 0.10 | 64.13 ± 1.37 |
| Δ <i>flhA</i> | 0.30 ± 0.03 | 1.55 ± 0.28 | 71.34 ± 3.65 |
| Δ <i>flhB</i> | 0.13 ± 0.10 | 0.26 ± 0.01 | 72.82 ± 3.79 |
| Δ <i>fliP</i> | 1.46 ± 0.22 | 1.41 ± 0.42 | 75.12 ± 2.29 |
| Δ <i>fliR</i> | 0.07 ± 0.01 | 0.06 ± 0.01 | 63.03 ± 2.64 |
| Δ <i>flgE</i> | 0.07 ± 0.01 | 0.19 ± 0.01 | 101.66 ± 3.76 |

a. Results are from a typical assay with each sample performed in triplicate. Values are reported as arylsulphatase units. One unit equals the amount of arylsulphatase required to generate 1 nmol of nitrophenol h⁻¹ per OD600 of 1.

b. Strains used include DRH533, DRH536, DRH536/pECO102, DRH536/pECO105, DRH830, DRH830/pECO102, DRH830/pDRH818, DRH936, DRH974, DRH1021, DRH1119, DRH1125, DRH1133 and DRH1204.

c. Strains used include DRH665, DRH667, DRH667/pECO102, DRH667/pECO105, DRH842, DRH842/pECO102, DRH842/pDRH818, DRH939, DRH1049, DRH1074, DRH1080, DRH1131, DRH1139 and DRH1178.

d. Strains used include DRH655, DRH658, DRH1046, DRH1047, DRH1048, DRH1070, DRH1070/pECO102, DRH1070/pECO106, DRH1122, DRH1128, DRH1136 and DRH1201.

e. ND, not determined.

jejuni. We examined transcription of *flaA*, which encodes the major flagellin under σ^{28} control (Hendrixson *et al.*, 2001), by constructing a *flaA::astA* reporter. This reporter was electroporated into the mutant backgrounds to replace wild-type *flaA* with the reporter fusion. Using the *flaA::astA* reporter, we confirmed our earlier observation (made using RT-PCR) that *flaA* transcription results at least in part from σ^{28} ; there remains significant *flaA::astA* transcription even in the absence of σ^{28} (Δ *fliA*; Table 2). Further evidence that σ^{28} is involved in *flaA* transcription includes the finding that overexpression of *fliA* from a plasmid led to elevated expression of *flaA::astA* (Table 2).

In contrast to σ^{54} -dependent expression of *flgDE2* and *flaB*, expression of *flaA::astA* was unaffected or reduced only slightly compared with wild type in strains with a disrupted flagellar secretion apparatus (Δ *flhA*, Δ *flhB*, Δ *fliP* and Δ *fliR* mutants), with mutations in the regulatory genes for σ^{54} -dependent flagellar gene expression (Δ *rpoN*, Δ *flgR* and Δ *flgS* mutants) or with a Δ *flgE* mutation, although these mutants do not produce flagella and are non-motile (Figs 1, 3 and 4; Hendrixson *et al.*, 2001; Jagannathan *et al.*, 2001). Similarly, transcription of *flaA* in 81-176 Δ *flhF* as determined by RT-PCR analysis was comparable to the level of *flaA* transcription in the wild-type strain (data not

shown). Clearly, further study is warranted regarding the activities of the σ^{28} -dependent promoter and the σ^{28} -independent promoter on transcription of *flaA*. However, if we assume that transcription from the σ^{28} -independent promoter is constant, these results suggest that, unlike in other bacteria, σ^{28} activity on transcription of *flaA* may generally be unaffected in mutants lacking a flagellar secretory apparatus or hook structure.

Characterization of *Cj1464* encoding an *FlgM* homologue in *flaA* transcription and motility

Considering that the level of *flaA::astA* transcription was close to or at the wild-type level in all the flagellar mutants and higher than the level of *flaA::astA* transcription in the Δ *fliA* mutant, we speculated that *C. jejuni* may lack an anti- σ^{28} factor like *FlgM* of other bacteria or may express a *FlgM* homologue that has only limited σ^{28} -repressive activity. Colland *et al.* (2001) identified a *FlgM* homologue in *Helicobacter pylori* and suggested that *Cj1464* encodes the corresponding gene product in *C. jejuni*. To test whether *Cj1464* encodes an anti- σ^{28} factor, we deleted the entire coding sequence of *Cj1464* (*flgM*) from 81-176 Sm^R and analysed *flaA* transcription by primer extension analysis. We detected two primer extension products that were one nucleotide different in size and dependent on σ^{28} , as determined by their absence in the Δ *fliA* mutant and appearance when this mutation was complemented by cloned *fliA* (Fig. 5, compare lane 1 with lanes 5 and 6). Relative amounts of σ^{28} -dependent *flaA* transcription were unaffected by the absence or overexpression of *flgM* (Fig. 5, lanes 1–4). One prominent σ^{28} -independent primer extension product was also identified. Except for the Δ *fliA* mutant, the strains analysed by primer extension were fully motile and produced normal flagella; the Δ *fliA* mutant showed reduced motility and produced shorter flagella as reported previously (Fig. 5B; data not shown; Hendrixson *et al.*, 2001; Jagannathan *et al.*, 2001).

As mutation of *flgM* did not affect expression of *flaA*, we explored whether *FlgM* could inhibit σ^{28} -dependent transcription of *flaA::astA* in *C. jejuni* if overexpressed. We reasoned that, by overexpressing *flgM* from a plasmid in 81-176 Δ *flhA* *flaA::astA* (DRH1048), which presumably does not produce a functional flagellar secretory apparatus, *FlgM* will not only be present at higher levels than normal but should be retained in the cytoplasm. Arylsulphatase activity from the *flaA::astA* reporter in wild-type bacteria overexpressing *flgM* compared with that from bacteria with vector alone was reduced from 91.6 arylsulphatase units to 76.1 arylsulphatase units (Fig. 6), a level of inhibition that we were apparently unable to detect using primer extension (Fig. 5A, compare lanes 1 and 2). Expression of the *flaA::astA* reporter in the Δ *flhA* mutant expressing *flgM* from the chromosome was reduced by

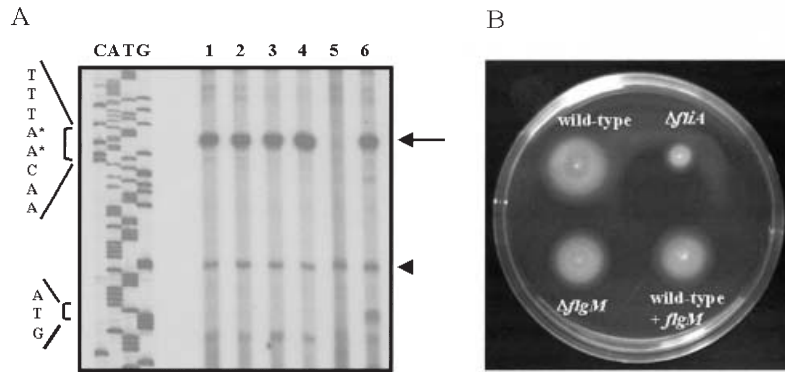

Fig. 5. Analysis of FlgM in transcription of *flaA* and motility in *C. jejuni*.

A. Primer extension analysis of *C. jejuni flaA* transcripts. Equal amounts of RNA from each strain were used in the primer extension reactions. The reaction products were run alongside a sequencing ladder of *flaA* from pDRH517 generated with the same primer used in the primer extension reactions. The σ^{28} -dependent primer extension products are indicated by an arrow, and the σ^{28} -independent primer extension products are indicated by an arrowhead. Two transcriptional start points for σ^{28} -dependent transcription are indicated by asterisks, and the *flaA* start codon is indicated. Lane 1, DRH212/pECO102 (wild-type 81-176 Sm^R/vector); lane 2, DRH212/pDRH820 (wild-type 81-176 Sm^R/pECO102::*flgM*); lane 3, DRH701/pECO102 (81-176 Δ *flgM*/vector); lane 4, DRH701/pDRH820 (81-176 Δ *flgM*/pECO102::*flgM*); lane 5, DRH311/pECO102 (81-176 Δ *flhA*/vector); and lane 6, DRH311/pDRH820 (81-176 Δ *flhA*/pECO102::*flhA*).

B. Motility phenotypes of *C. jejuni* strains in MH motility media. Strains include DRH212 (wild-type 81-176 Sm^R), DRH311 (81-176 Δ *flhA*), DRH701 (81-176 Δ *flgM*) and DRH212/pDRH820 (wild-type 81-176 Sm^R/pECO102::*flgM*).

about 20% (Fig. 6), suggesting that FlgM activity is not a major checkpoint of transcription when cells are unable to assemble the flagellum properly. The response in *flaA* expression seen in cells that lack *flhA* is similar to the small magnitude of the FlgM effect in wild-type cells overexpressing FlgM (Fig. 6). Only by overexpressing *flgM* in the Δ *flhA* mutant was expression of the *flaA*::*astA* reporter reduced to a level (59.8 arylsulphatase units) that approached that seen in the Δ *flhA* (σ^{28}) mutant (52 arylsulphatase units; Fig. 6). We draw two conclusions from these results: first, that transcription of *flaA* is not entirely dependent upon σ^{28} and, secondly, that FlgM does not appear to play a major role in the net levels of *flaA* expression in *C. jejuni*, which is unlike what is seen with σ^{28} -

dependent transcription of the major flagellin in other bacteria.

Discussion

In this report, we elucidated key portions of the flagellar regulatory cascade in *C. jejuni* by exploiting a new reporter gene system based on the *astA* gene encoding arylsulphatase in combination with transposon mutagenesis. This reporter gene may be a valuable tool in future gene regulation studies in *C. jejuni*. The use of *lacZ* as a reporter for *C. jejuni* has been demonstrated previously (Wösten *et al.*, 1998; Baillon *et al.*, 1999; van Vliet *et al.*, 2001; Matz *et al.*, 2002), but these studies have been

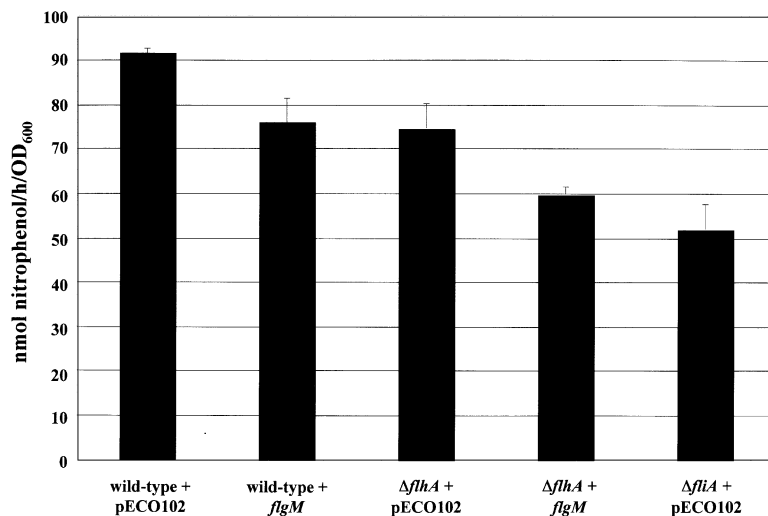

Fig. 6. Analysis of *flgM* overexpression in strains containing the *flaA*::*astA* transcriptional reporter. Each strain was tested in triplicate, and the values reported represent the average arylsulphatase activity \pm standard deviation from a representative assay. One arylsulphatase unit equals the amount of arylsulphatase necessary to generate 1 nmol of nitrophenol h⁻¹ per OD₆₀₀ of 1. Strains used include DRH655/pECO102, DRH655/pDRH820, DRH1048/pECO102, DRH1048/pDRH820 and DRH1070/pECO102.

conducted with reporter gene fusions present on plasmids not the chromosome, which is not always ideal. We were unable successfully to create *lacZ* reporter fusion constructs on the chromosome of *C. jejuni*, eliminating the possibility of studying regulation of genes in single copy. An additional limitation of *lacZ* fusions in *C. jejuni* is the reported inability of *C. jejuni* derivatives harbouring *lacZ* reporter genes to grow on media containing the chromogenic substrate 5-bromo-4-chloro-3-indolyl- β -galactose (Xgal; Wösten *et al.*, 1998). By adapting *astA* as a reporter in *C. jejuni* strains lacking the native *astA* locus, we have developed a reporter gene system that allows for easy monitoring of gene expression on agar plates containing the chromogenic substrate XS and spectrophotometrically in whole-cell lysates.

By combining the use of flagellar gene-*astA* fusions, transposon mutagenesis and defined deletion mutagenesis, we were able to reveal critical elements of the flagellar transcriptional cascade in *C. jejuni*. Our model for the flagellar transcriptional cascade is depicted in Fig. 7. In *S. typhimurium*, *C. crescentus* and *V. cholerae*, master regulators (such as FlhDC, CtrA and FlrA) are at the top of the flagellar transcriptional cascade and control the transcription of many flagellar genes including genes for the flagellar secretory apparatus (Kutsukake and Iino, 1994; Quon *et al.*, 1996; Prouty *et al.*, 2001). Annotation of the *C. jejuni* genome sequence suggests that these master regulators are absent from the bacterium, which may imply that *flhF* and genes encoding the putative flagellar secretory apparatus in *C. jejuni* such as *flhA*, *flhB*, *fliP* and *fliR* are transcribed constitutively or regulated differently from other bacteria. We do not believe that σ^{54} is responsible for transcription of these genes as σ^{54} binding sites appear to be absent from the

promoter regions of these genes; future experiments will address this point directly.

The extent of RpoN (σ^{54}) control over flagellar motility in *C. jejuni* is not fully determined as yet. The $\Delta rpoN$ mutant is non-motile and lacks flagella (Hendrixson *et al.*, 2001; Jagannathan *et al.*, 2001). The genes that we have shown to require σ^{54} for transcription include *flgDE2* and *flaB* (Hendrixson *et al.*, 2001). However, a mutant with a transposon insertion in *flgD* has reduced motility, and disruption of *flgE2* and *flaB* do not affect motility (Wassenaar *et al.*, 1991; Hendrixson *et al.*, 2001). As the $\Delta rpoN$ mutant has a more severe motility defect than the *flgD* mutant, it seems likely that other flagellar genes required for motility are dependent on σ^{54} for transcription. By scanning the genome sequence of *C. jejuni* (Parkhill *et al.*, 2000), we identified potential σ^{54} binding sites in the promoter regions of *flgE* and many other flagellar genes encoding putative flagellar basal body, ring and hook-associated proteins, such as *flgK* (*Cj1466*), *fliE* (*Cj0526c*), *flgC* (*Cj0527c*), *flgB* (*Cj0528c*), *flgH* (*Cj0687c*), *flgG2* (*Cj0697*), *flgG* (*Cj0698*) and *flgI* (*Cj1462*); a previous study determined that *flgK* and *flgB* mutants of *C. jejuni* are non-motile (Golden and Acheson, 2002). These genes are indicated in the box located in Fig. 7. Analysis of transcription of these genes may further elucidate the flagellar regulatory cascade and the role of σ^{54} in flagellar gene expression and motility.

In our model, we propose three classes of σ^{54} -dependent genes represented by *flgE*, *flgDE2* and *flaB* (Fig. 7). We present a proposed order of transcription of these three classes; however, our data alone do not suggest that this temporal regulation is absolutely correct. We did observe that transcription of *flgDE2* and *flaB* was dependent on intact *flgE*, suggesting that this gene is upstream

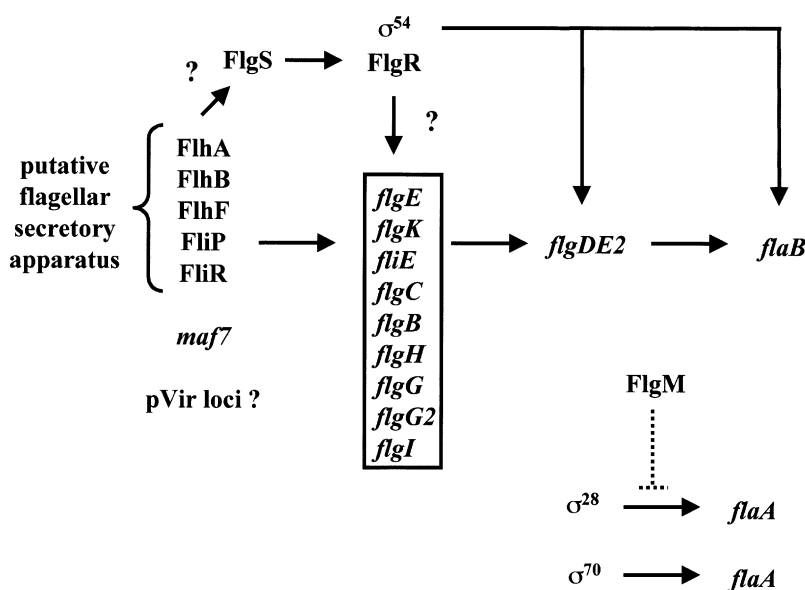

Fig. 7. Model of flagellar transcriptional cascade in *C. jejuni*. Genes with a promoter containing putative σ^{54} binding sites that have not been shown to date to be dependent on σ^{54} for transcription are indicated in a box. The proteins indicated to the left of the figure within a bracket are postulated to play a role in transcriptional control of the boxed σ^{54} - and FlgR-dependent genes and in post-translational control over FlgS function. The weak FlgM repressive activity for σ^{28} is indicated by a dashed line. See Discussion for details.

of these other two flagellar genes in the transcriptional cascade. Additionally, genes for flagellins such as *flaB* are usually transcribed downstream of flagellar hook-associated genes in the flagellar transcriptional cascade of other bacteria, leading us to suggest that transcription of *flaB* in *C. jejuni* may be dependent upon *flgDE2* as well. If the proposed temporal regulation of transcription is indeed correct, this finding would suggest that there are unknown factors present in *C. jejuni* controlling the ordered regulation of these three σ^{54} -dependent flagellar genes.

In our model, FlgR, presumably upon activation as a result of phosphorylation by FlgS under appropriate signals, functions as a transcriptional activator required by σ^{54} to initiate transcription. Mutants lacking σ^{54} , FlgR and FlgS failed to transcribe the σ^{54} -dependent flagellar genes *flgDE2* and *flaB*. Because of the homology that FlgS and FlgR exhibit with other sensor kinases and NtrC-like response regulators, respectively, we propose that the two proteins constitute a two-component regulatory system governing σ^{54} -dependent transcription of flagellar genes in *C. jejuni*.

A major observation from our studies is that σ^{54} -dependent transcription of flagellar genes in *C. jejuni* is apparently linked to the formation of the flagellar secretory apparatus (encoded in part by *flhA*, *flhB*, *fliP* and *fliR*). This aspect of flagellar gene regulation in *C. jejuni* is similar to that seen in *C. crescentus*. In this bacterium, transcription of hook, basal body and flagellin genes is dependent not only on σ^{54} and the σ^{54} -dependent transcriptional activator FliB, but also on components believed to function as the flagellar secretory apparatus (such as FliA, FliP and FliR) and the MS ring and flagellar switches (such as FliF, FliM, FliG and FliN; Benson *et al.*, 1994; Ramakrishnan *et al.*, 1994; Wu *et al.*, 1995; Wu and Newton, 1997). However, activation of transcription of the flagellar genes by FliB is not well understood, and no sensor kinase has yet been identified controlling the activity of FliB.

Given that FlgS is a putative sensor kinase that may control the activation of the σ^{54} -dependent pathway potentially through the activation of FlgR by phosphorylation in *C. jejuni*, we speculate that FlgS may be the direct sensor determining whether conditions are appropriate for transcription of σ^{54} -dependent flagellar genes to ensue. In this context, FlgS may be able directly to detect proper formation of the flagellar secretory apparatus, initiating σ^{54} -dependent transcription of flagellar genes. Biochemical analysis regarding the activity of FlgS and the phosphorylation state of FlgR in wild-type bacteria and the various flagellar mutants may help to elucidate the connection between the formation of the flagellar secretory apparatus and the activation of transcription of σ^{54} -dependent flagellar genes in *C. jejuni*. Of relevance to this model is the

subcellular localization of FlgS; the hydropathicity plot of the protein sequence is not conclusive, although it appears that the protein lacks extensive transmembrane domains by the Kyte–Doolittle criteria. Thus, it would seem that whatever sensing role FlgS may play could take place in the cytoplasm. Further work on this protein is needed before a mechanism for its role in flagellar regulation can be ascertained.

Another feature of the flagellar transcriptional cascade of *C. jejuni* demonstrated in our study is the lack of significant repression of *flaA* transcription in our flagellar secretory apparatus mutants. One likely reason why we did not see complete repression of σ^{28} -mediated transcription of *flaA* in these mutants is that FlgM in *C. jejuni* 81-176 appears to be a weak repressor of σ^{28} transcriptional activity. In many of our flagellar mutants, we observed either no or only a slight reduction in transcription of the *flaA::astA* reporter, which was still above the level of transcription seen in a $\Delta fliA$ mutant. Even under the non-physiological conditions in which FlgM was overproduced in a $\Delta flhA$ mutant, the level of *flaA::astA* transcription was still slightly above that found in a $\Delta fliA$ mutant. Based on our experimental results, it is questionable whether FlgM acts in a significant way to regulate σ^{28} in *C. jejuni*, as originally suggested by Colland *et al.* (2001), who identified a putative anti- σ^{28} factor signature in FlgM of *C. jejuni*. In addition to the limited effect of FlgM, there is also considerable σ^{28} -independent expression of *flaA* in *C. jejuni* 81-176 that would probably be outside the influence of anti- σ factor function.

We can only speculate why FlgM does not significantly reduce σ^{28} activity in *C. jejuni*. One possibility is that the protein has diverged sufficiently so that it no longer interacts with σ^{28} . Alignment of the *C. jejuni* FlgM and σ^{28} proteins with homologous proteins from other bacteria reveals a significant amount of amino acid sequence divergence (data not shown; Colland *et al.*, 2001). This sequence divergence in the two proteins may suggest that FlgM and σ^{28} do not have a high affinity for each other in *C. jejuni*, preventing a productive interaction required to repress σ^{28} activity. However, FlgM and σ^{28} from *C. jejuni* are most closely related to their homologues in *H. pylori*, and FlgM of *H. pylori* can both prevent σ^{28} and RNA polymerase from interacting and repress σ^{28} transcriptional activity in this bacterium (Colland *et al.*, 2001). Plus, despite the apparent divergence in amino acid sequences between the FlgM and σ^{28} proteins of *H. pylori* and *S. typhimurium*, the *H. pylori* FlgM could complement an *S. typhimurium flgM* mutant to repress σ^{28} transcriptional activation of the major flagellin by one-third (Josenhans *et al.*, 2002), suggesting that sequence divergences of one or both the proteins through evolution has not prevented the formation of repressive FlgM- σ^{28} complexes.

Another reason for transcription of *flaA* in our flagellar regulatory and secretory apparatus mutants is that approximately half the transcription of *flaA* results from a σ^{28} -independent promoter, based on the activity of the *flaA::astA* reporter in the wild-type strain versus the $\Delta fliA$ mutant. Currently, we do not know the location of the promoter or the start of transcription for this σ^{28} -independent activity of *flaA* transcription. In our primer extension analysis, we did detect a fainter product, the 5' end of which is located close to the *flaA* start codon, but we do not currently know whether this is the true start point of transcription from a σ^{28} -independent promoter. Additional analysis of *flaA* transcription and FlaA protein levels in a $\Delta fliA$ mutant may reveal the identity of this promoter and its contribution to FlaA levels.

A feature of flagellar biosynthesis in the *Salmonella* model, in which σ^{28} -dependent transcription of the major flagellin gene is inhibited in flagellar secretory apparatus mutants, may generally not hold for *Campylobacter* and *Helicobacter* species. In *Campylobacter coli*, which is closely related to *C. jejuni*, primer extension analyses suggested that, in a *flgE* mutant, transcription of both *flaA* and *flaB* (which as in *C. jejuni* are presumed to involve σ^{28} and σ^{54} for transcription respectively) was unaffected (Guerry *et al.*, 1990; 1991; Kinsella *et al.*, 1997). Furthermore, in *H. pylori*, mutation of *flgR*, a homologue of the *C. jejuni flgR*, which is required for transcription of certain flagellar basal body and hook proteins, did not lead to reduced σ^{28} -mediated transcription of *flaA* and actually resulted in a slight increase in transcription of this gene (Spohn and Scarlato, 1999). In addition, disruption of *flgE* in *H. pylori* did not appear to decrease FlaA protein levels significantly (O'Toole *et al.*, 1994). Evidence contrary to these findings includes the observation that, in an *H. pylori flhA* mutant, no *flaA* transcripts were detected (Schmitz *et al.*, 1997). Allan *et al.* (2000) also showed that, in other *H. pylori* flagellar mutants such as an *flhB* mutant, *flaA* transcripts were reduced two- to fourfold, but were still detectable. Each of these *H. pylori* studies used different strains, perhaps suggesting lack of conservation of repressing *flaA* transcription in this bacterium.

Contrary to our findings showing that *flaA::astA* transcription is not affected in a *flhB*, *flgR* or *rpoN* mutant, others have reported that, in *C. jejuni* strains other than 81-176, *flaA* transcription was reduced or FlaA protein levels were abolished in strains lacking one of these genes (Jagannathan *et al.*, 2001; Matz *et al.*, 2002). Jagannathan *et al.* (2001) reported loss of detectable flagellin (both FlaA and FlaB) by mutation in either *rpoN* or *flgR* and suggested that neither flagellin gene was transcribed in either mutant. On the contrary, our results show that *flaA* transcription is not affected in these mutants, whereas *flaB* transcription is abolished. Using the *flaA::astA* or *flaB::astA* reporter fusions, we were able

specifically to analyse transcription from either the *flaA* or the *flaB* promoter and reliably make conclusions regarding the levels of transcription of *flaA* and *flaB* in various flagellar mutants. Use of these reporters in other strains of *C. jejuni* may provide insight regarding whether this apparent FlgM independence of σ^{28} activity is a common feature among *C. jejuni* strains.

In this work, we have provided insight into the flagellar transcriptional cascade in *C. jejuni*. We have identified flagellar genes and regulatory factors that are required for activation of the σ^{54} arm of the flagellar transcriptional pathway. A major factor that allowed us to accomplish these goals was the creation of *astA* as a reporter gene in *C. jejuni* combined with recent developments in random transposon mutagenesis and defined deletion mutagenesis in the organism (Hendrixson *et al.*, 2001). Whereas new insights in the *C. jejuni* flagellar transcriptional cascade were revealed, many questions remained unanswered regarding how many other flagellar genes are regulated in the organism. Biochemical analysis of the putative FlgS–FlgR two-component regulatory system will increase our understanding regarding how σ^{54} -dependent transcription of flagellar genes is accomplished. Considering our findings, it is apparent that the flagellar transcriptional cascade in *C. jejuni* has aspects similar to that of *C. crescentus* with regard to requirements for activation of transcription of σ^{54} -dependent flagellar genes, but also includes σ^{28} in transcription of the major flagellin, similar to what is seen in other bacterial organisms such as *S. typhimurium*. Despite similarities to these two systems, our current understanding of the flagellar transcriptional cascade in *C. jejuni* suggests that the bacterium does not entirely follow the flagellar regulatory hierarchy of either organism.

Experimental procedures

Bacterial strains and plasmids

All bacterial strains and plasmids used in this study are described in Table S1 in *Supplementary material*. *C. jejuni* was grown in microaerophilic conditions at 37°C on Mueller–Hinton (MH) agar. Microaerophilic conditions were generated by inflating plastic sealed bags with a gas mixture containing 85% nitrogen, 10% carbon dioxide and 5% oxygen. For *C. jejuni*, antibiotics were used at the following concentrations: trimethoprim, 10 $\mu\text{g ml}^{-1}$; cefoperazone 30 $\mu\text{g ml}^{-1}$; kanamycin, 50 $\mu\text{g ml}^{-1}$; chloramphenicol, 15 $\mu\text{g ml}^{-1}$; and streptomycin, 0.5, 1 or 2 mg ml^{-1} . For detection of arylsulphatase, XS was added to a final concentration of 100 $\mu\text{g ml}^{-1}$ in MH agar. All *C. jejuni* strains were stored at -80°C in MH broth containing 15% glycerol. *E. coli* DH5 α and DH5 α pir were grown in Luria–Bertani (LB) agar or broth. For *E. coli*, antibiotics were used at the following concentrations: ampicillin, 100 $\mu\text{g ml}^{-1}$; kanamycin, 50 $\mu\text{g ml}^{-1}$; and chloramphenicol, 15 $\mu\text{g ml}^{-1}$. All *E. coli* strains were stored at -80°C in LB containing 20% glycerol.

Construction of defined deletion mutants

In addition to using a *cat-rpsL* cassette to facilitate the creation of defined deletion mutants, a *kan-rpsL* cassette was also created. A *SmaI*-digested *aphA-3* cassette from pILL600 (Labigne-Roussel *et al.*, 1988) was cloned into the *HincII* site of pDRH172 (Hendrixson *et al.*, 2001) to insert *aphA-3* next to the cloned *rpsL* gene. This plasmid was designated pDRH436. The *kan-rpsL* cassette was then amplified by polymerase chain reaction (PCR) with primers containing 5' *SmaI* restriction sites, purified and cloned into *SmaI*-digested pUC19 to create pDRH437. This plasmid was the source of the *kan-rpsL* cassette.

The method for construction of defined deletion mutants in *C. jejuni* has been described previously (Hendrixson *et al.*, 2001). To construct a defined deletion mutation of *astA* in *C. jejuni* strain 81-176, pDRH138 harbouring the *astA* locus (Wiesner *et al.*, 2003) was digested with *EcoRV*, and the *SmaI*-digested *cat-rpsL* cassette was ligated into this site to interrupt the gene. This plasmid, pDRH424, was electroporated into 81-176 Sm^R (DRH212) to replace *astA* with *astA::cat-rpsL* to create DRH435. A SOEing reaction (Higuchi, 1990) was performed to fuse the upstream and downstream DNA fragments surrounding *astA*, creating an in frame fusion linking the start codon of *astA* to codon 611 of the gene. This fragment was cloned as a *PstI* fragment into pUC19 to create pDRH449. This plasmid was electroporated into DRH435 by the method of van Vliet *et al.* (1997) to replace *astA::cat-rpsL* with the *astA* deletion construct in the chromosome, creating DRH461 (81-176 Sm^R Δ *astA*).

Chromosomal DNA from *C. jejuni* strain 81-176 was used in PCR with primers containing specific 5' restriction sites to amplify various fragments containing *flgR*, *flhA*, *flhF*, *fliP*, *fliR*, *flgE* and *flgM*. The fragments were cloned into either pUC19 or pBR322 (for a description of the plasmids, see Table S1 in *Supplementary material*). Each gene was then interrupted by ligation of a *SmaI*-digested *cat-rpsL* cassette from pDRH265 (Hendrixson *et al.*, 2001) or a *SmaI*-digested *kan-rpsL* cassette from pDRH437 into an appropriate restriction site to create plasmids used to electroporate 81-176 Sm^R (DRH212) or 81-176 Δ *astA* (see Table S1 in *Supplementary material*). Because of the lack of suitable restriction sites in *flhF*, pUC19 harbouring *flhF* (pDRH416) was subjected to site-specific PCR mutagenesis (Makarova *et al.*, 2000) to create an *EcoRV* site 703 bp into the *flhF* coding sequence. This plasmid, pDRH434, was then digested with *EcoRV* to insert the *cat-rpsL* cassette to interrupt *flhF* and create pDRH468. The electroporated plasmids replaced the chromosomal copies of the wild-type genes with the respective *cat-rpsL*- or *kan-rpsL*-interrupted genes. These strains were the intermediate strains that were used in the final step to create the defined deletion chromosomal mutations. Sequencing of the cloned *fliP* and *flgE* loci of *C. jejuni* 81-176 revealed significant differences compared with the respective genes in *C. jejuni* NCTC11168. The 81-176 *fliP* and *flgE* sequences have been deposited in GenBank with the accession numbers AY277719 and AY277720 respectively.

Because of difficulty in cloning *flgS* and because of the lack of suitable restriction sites in *flhB*, SOEing reactions (Higuchi, 1990) were performed to generate fusions of the

upstream and downstream DNA regions of *flgS* and *flhB*. In creating the fusions, an in frame *StuI* restriction site was created to link the two DNA segments. For *flgS*, \approx 750 bp of upstream and downstream DNA sequence was fused with a *StuI* site at the junction of the fusion. This fragment replaced the entire coding sequence of *flgS* with the *StuI* site. The fragment was cloned as a *BamHI* fragment into pBR322 to create pDRH425. The *SmaI*-digested *cat-rpsL* cassette was cloned into *StuI*-digested pDRH425 to create pDRH426. For *flhB*, a 1.5 kb SOEing product was generated that fused an in frame *StuI* site linking the start codon to codon 365, deleting the intervening coding sequence of *flhB*. This fragment was cloned as a *BamHI* fragment into pUC19 to create pDRH742. The *SmaI*-digested *cat-rpsL* cassette was cloned into *StuI*-digested pDRH742 to create pDRH781. Plasmid pDRH781 was electroporated into *C. jejuni* 81-176 Sm^R (DRH212) or 81-176 Δ *astA* (DRH461) to replace *flhB* with *flhB::cat-rpsL*. Plasmid pDRH426 was electroporated into 81-176 Sm^R (DRH212) to replace *flgS* with *cat-rpsL*. These strains were the intermediate strains that were used in the final step to create the defined deletion chromosomal mutations.

SOEing reactions (Higuchi, 1990) or deletion mutagenesis PCR (Makarova *et al.*, 2000) were performed to generate fusions of the upstream and downstream DNA segments surrounding *flgR*, *flhA*, *flhF*, *fliP*, *fliR*, *flgE* and *flgM*. Each deletion fragment was cloned into pUC19 (the constructed plasmids are described in Table S1 in *Supplementary material*). These plasmids were electroporated into the respective 81-176 Sm^R (DRH212) and 81-176 Δ *astA* (DRH461) intermediate strains to replace the *cat-rpsL* mutations with the deletion constructs. Transformants were recovered on MH agar containing 0.5, 1 or 2 mg ml⁻¹ streptomycin and then selected for chloramphenicol sensitivity on MH agar containing 15 μ g ml⁻¹ chloramphenicol. All mutants were verified for deletion of appropriate genes by colony PCR.

To delete *astA* in DRH311 (81-176 Δ *fliA*), DRH321 (81-176 Δ *rpoN*) and DRH460 (81-176 Δ *flgS*), DRH311 and DRH321 were first electroporated with pDRH424 to replace *astA* with *astA::cat-rpsL*, and DRH460 was electroporated with pDRH444 to replace *astA* with *astA::kan-rpsL*. The obtained mutants were then electroporated with pDRH449 to replace the insertionally inactivated *astA* with the *astA* deletion construct as described above.

To generate complementing plasmids for *C. jejuni* to express genes from the *C. jejuni* chloramphenicol acetyltransferase (*cat*) promoter, the coding sequences from the second codon to the stop codon of *rpoN*, *fliA*, *flgR* and *flgM* were amplified by PCR from the chromosomal DNA of *C. jejuni* strain 81-176. Primers used for the amplification contained 5' *BamHI* restriction sites in frame to codon 2 and the stop codon of each gene. The amplified fragments were purified and cloned into the *BamHI* site of pECO102 (Wiesner *et al.*, 2003). Plasmids were screened to ensure that each fragment was inserted into the correct orientation in the plasmid allowing for expression of the genes from the *cat* promoter. In each plasmid, expression of the gene results in a protein encoding a methionine, followed by a glycine and a serine (resulting from the codons provided by the in frame *BamHI* site), and then followed by the amino acids encoded by codons 2 to the stop codon of each gene. Each plasmid

was transformed into *E. coli* DH5 α /RK212.1 (Figurski and Helinski, 1979) and conjugated into the appropriate 81-176 strain by the method of Guerry *et al.* (1994).

Construction of the *astA*–*kan* reporter gene cassette and the *nemo* transposon

To construct an *astA*–*kan* cassette, *aphA-3* (encoding kanamycin resistance) was purified as a *Sma*I fragment from pILL600 and ligated into *Hinc*II-digested pUC19 to create pDRH371. Primers containing 5' *Pst*I restriction sites were constructed to amplify a promoterless *astA* fragment from the chromosome of *C. jejuni* 81-176. This fragment extended from 14 bp upstream of the start codon to the stop codon of *astA* and retained the ribosomal binding site of the gene. This fragment was digested with *Pst*I and ligated into *Pst*I-digested pDRH371 to create pDRH466. The *astA*–*kan* fragment was then amplified by PCR with primers containing 5' *Mlu*I sites and ligated into *Mlu*I-digested pFalcon (Hendrixson *et al.*, 2001). Digestion of pFalcon with *Mlu*I followed by ligation of the *Mlu*I-digested *astA*–*kan* cassette replaced the *kan* cassette in the *solo* transposon backbone with the *astA*–*kan* cassette, creating pNautilus harbouring the transposon *nemo*.

To insert *nemo* into *flgE2*, a 4.2 kb fragment harbouring *flgDE2* was amplified by PCR from the chromosome of strain *C. jejuni* 81-176 with primers containing 5' *Kpn*I sites. The fragment was digested with *Kpn*I and ligated into *Kpn*I-digested pUC19 to create pDRH351. *Himar*1 C9 transposase was purified from DH5 α /pMALC9 (Akerley and Lampe, 2002). Transposition reactions contained 1 μ g of purified pNautilus, 2 μ g of pDRH351 and 500 ng of purified *Himar*1 C9 transposase in a total volume of 80 μ l as described previously (Hendrixson *et al.*, 2001). Plasmid DNA was purified by phenol–chloroform extraction, ethanol precipitated and transformed into DH5 α . One plasmid, pDRH532, was recovered that contained *nemo* inserted 515 bp downstream of the *flgE2* start codon in the correct orientation to generate a *flgDE2::astA* transcriptional fusion. This plasmid was then electroporated into 81-176 Δ *astA* (DRH461), replacing *flgDE2* with *flgDE2::nemo* to generate the reporter strain 81-176 Δ *astA flgDE2::nemo* (DRH533).

Isolation and identification of mutants defective for transcription of *flgDE2::astA*

The *picard* transposon was amplified from pEnterprise (Hendrixson *et al.*, 2001) by PCR using primers that added 5' *Pme*I restriction sites. The amplified fragment contained *picard* with 98 bp of 5' sequence and 217 bp of 3' sequence. After digestion of pUC19 with *Eco*RI and *Hind*III, blunt ends were generated by filling in the overhangs generated by restriction enzyme digestion with T4 DNA polymerase (Invitrogen), and the *Pme*I-digested PCR fragment containing *picard* was ligated into the plasmid to generate pEnterprise2.

Chromosomal DNA from strain DRH533 was purified and used in 39 individual *in vitro* transposition reactions containing 2 μ g of chromosomal DNA, 1 μ g of pEnterprise2 (harbouring the *picard* transposon) and 500 ng of purified *Himar*1 C9 transposase. Transposition reactions and repair and transfor-

mation reactions were performed as above and as described previously (Hendrixson *et al.*, 2001). Approximately 14 000 transformants were recovered on MH agar containing 15 μ g ml⁻¹ chloramphenicol and 100 μ g ml⁻¹ XS. *C. jejuni* mutants defective for transcription of *flgDE2::astA* were identified as white colonies after growth on this agar. The sequence surrounding the *picard* transposon in each mutant was determined by direct sequencing of DNA from chromosomal preparations or by inverse PCR (Ochman *et al.*, 1988), followed by sequencing of the generated PCR products.

Construction of chromosomal transcriptional reporter gene fusions

To create a convenient *astA*–*kan* cassette for cloning into various genes to create functional *astA* transcriptional fusion constructs, *astA*–*kan* from pDRH466 was amplified by PCR with primers that contained 5' *Sma*I restriction sites. The amplified DNA was purified, digested with *Sma*I and ligated into *Sma*I-digested pUC19 to create pDRH580.

Chromosomal DNA from *C. jejuni* strain 81-176 was used to amplify by PCR a 2.1 kb fragment containing *flaA* and a 4.3 kb fragment containing *flaAB*. For each fragment, specific primers were used that contained 5' *Bam*HI sites. Each fragment was purified, digested with *Bam*HI and ligated to *Bam*HI-digested pUC19. The plasmid containing *flaA* was designated pDRH517, and the plasmid containing *flaAB* was designated pDRH519. The *Sma*I-digested *astA*–*kan* cassette from pDRH580 was then ligated into *Eco*RV-digested pDRH517 and *Hpa*I-digested pDRH519 to insert the cassette into the coding sequence of *flaA* and *flaB* respectively. The constructs were screened to ensure that the *astA*–*kan* cassette was inserted into the correct orientation to create functional transcriptional fusions of *flaA* and *flaB* to *astA*. The plasmid containing the *flaA::astA* fusion was designated pDRH608, and the plasmid containing the *flaB::astA* fusion was designated pDRH610. Each plasmid was purified and electroporated into appropriate *C. jejuni* Δ *astA* mutants to replace *flaA* or *flaB* with the respective transcriptional reporter gene constructs.

Motility assays

To examine the motility phenotype of various *C. jejuni* 81-176 derivatives, strains were streaked on MH agar (or MH agar containing 15 μ g ml⁻¹ chloramphenicol when appropriate) and grown at 37°C under microaerophilic conditions for 48 h. Each strain was then restreaked heavily onto three appropriate MH agar plates and grown at 37°C under microaerophilic conditions for 16 h. Each strain was resuspended and diluted in MH broth to an OD₆₀₀ of 0.7 and then stabbed with a needle into MH motility media containing 0.4% agar. Motility phenotypes were examined after incubation of plasmids at 37°C under microaerophilic conditions for 48 h.

Transmission electron microscopy

To examine the presence of flagella on *C. jejuni* 81-176 derivatives, strains were grown on MH agar for 48 h at 37°C

under microaerophilic conditions. Nickel-coated copper grids were soaked in 0.1% poly L-lysine for 1 min, and then excess poly L-lysine was removed. The copper side of each grid was touched to a colony on an MH agar plate, and the grid was then soaked in 4% paraformaldehyde containing 0.2% glutaraldehyde solution for 1 min. Grids were soaked twice in water for 30 s and then stained in 1% uranyl acetate for 1 min. The grids were visualized with a Philips CM100 transmission electron microscope at 60 kV.

Arylsulphatase assays

Arylsulphatase in whole cells of *C. jejuni* was analysed by protocols based on the methods of Henderson and Milazzo (1979) and Yao and Guerry (1996). *C. jejuni* strains were streaked on MH agar and grown at 37°C under microaerophilic conditions for 48 h. Each strain was then streaked heavily onto three separate MH agar plates and grown for 16 h at 37°C under microaerophilic conditions. Each plate was considered as a different sample for each strain so that each strain was tested in triplicate in each assay. Growth from each plate was resuspended in PBS to an OD₆₀₀ between 0.6 and 1. Each sample was then divided into two 1 ml aliquots. One aliquot was washed once in arylsulphatase buffer 1 (AB1; 0.1 M Tris, pH 7.2) and then resuspended in 1 ml of AB1. The other aliquot was washed once in arylsulphatase buffer 2 (AB2; 2 mM tyramine, 0.1 M Tris, pH 7.2) and then resuspended in 1 ml of AB2. Two hundred microlitres of each sample was then added to 200 µl of freshly prepared arylsulphatase buffer 3 (AB3; 20 mM nitrophenylsulphate, 0.1 M Tris, pH 7.2). Reactions were incubated for 1 h at 37°C and then stopped by the addition of 800 µl of 0.2 N NaOH. To measure arylsulphatase activity, 1 ml of each sample was measured spectrophotometrically at OD₄₁₀ to obtain a reading for the amount of nitrophenol released. The samples resuspended in AB1 served as blanks for the respective samples resuspended in AB2 when arylsulphatase activity was measured spectrophotometrically. To determine the amount of nitrophenol released, values were compared to a standard curve of OD₄₁₀ readings from known concentrations of nitrophenol. One arylsulphatase unit is defined as the amount of enzyme catalysing the release of 1 nmol of nitrophenol h⁻¹ per OD₆₀₀ of 1.

RT-PCR and primer extension analysis

Purification of RNA using Trizol reagent (Invitrogen) and RT-PCR using random primers and Superscript II reverse transcriptase (Invitrogen) was performed according to the manufacturer's instructions and as described previously (Hendrixson *et al.*, 2001). Amplification of products in the subsequent PCRs involved the use of specific primers for *flaA*, *flgE2* and *rpoA*. For primer extension reactions, a primer for *flaA* (5'-AGCATCTAAACTTTTAGCATT-3') binding 81 bp downstream of the start codon was end labelled with [³²P]-ATP by T4 DNA kinase (Invitrogen). Primer extension reactions were performed as described previously using 11 µg of RNA (Higgins and DiRita, 1994). Products from the primer extension reactions were run on a 6% polyacrylamide sequencing gel alongside a sequencing ladder (generated

using the Thermo Sequenase radiolabelled terminator cycle sequencing kit; USB Corporation) of *flaA* from pDRH517 using the above *flaA* primer.

Acknowledgements

We thank Erin O'Rourke for construction of pECO105 and pECO106. This work was supported by USDA grant 2002/3520/111672 to V.J.D. D.R.H. was supported by National Research Service Award DK59710 from the National Institute of Diabetes and Digestive and Kidney Diseases.

Supplementary material

The following material is available from <http://www.blackwellpublishing.com/products/journals/suppmat/mmi/mmi3731/mmi3731sm.htm>

Table S1. Bacterial strains and plasmids used in this study.

References

- Akerley, B.J., and Lampe, D.J. (2002) Analysis of gene function in bacterial pathogens by GAMBIT. *Methods Enzymol* **358**: 100–108.
- Allan, E., Dorrell, N., Foynes, S., Anyim, M., and Wren, B.W. (2000) Mutational analysis of genes encoding the early flagellar components of *Helicobacter pylori*: evidence for transcriptional regulation of flagellin A biosynthesis. *J Bacteriol* **182**: 5274–5277.
- Arora, S.K., Ritchings, B.W., Almira, E.C., Lory, S., and Ramphal, R. (1998) The *Pseudomonas aeruginosa* flagellar cap protein, Flid, is responsible for mucin adhesion. *Infect Immun* **66**: 1000–1007.
- Bacon, D.J., Alm, R.A., Burr, D.H., Hu, L., Kopecko, D.J., Ewing, C.P., *et al.* (2000) Involvement of a plasmid in the virulence of *Campylobacter jejuni* 81-176. *Infect Immun* **68**: 4384–4390.
- Bacon, D.J., Alm, R.A., Hu, L., Hickey, T.E., Ewing, C.P., Batchelor, R.A., *et al.* (2002) DNA sequence and mutational analyses of the pVir plasmid of *Campylobacter jejuni* 81-176. *Infect Immun* **70**: 6242–6250.
- Baillon, M.L., van Vliet, A.H., Ketley, J.M., Constantinidou, C., and Penn, C.W. (1999) An iron-regulated alkyl hydroperoxide reductase (AhpC) confers aerotolerance and oxidative stress resistance to the microaerophilic pathogen *Campylobacter jejuni*. *J Bacteriol* **181**: 4798–4804.
- Benson, A.K., Ramakrishnan, G., Ohta, N., Feng, J., Ninfa, A.J., and Newton, A. (1994) The *Caulobacter crescentus* FlbD protein acts at *flr* sequence elements both to activate and to repress transcription of cell cycle-regulated flagellar genes. *Proc Natl Acad Sci USA* **91**: 4989–4993.
- Black, R.E., Levine, M.M., Clements, M.L., Hughes, T.P., and Blaser, M.J. (1988) Experimental *Campylobacter jejuni* infection in humans. *J Infect Dis* **157**: 472–479.
- Carpenter, P.B., Hanlon, D.W., and Ordal, G.W. (1992) *flhF*, a *Bacillus subtilis* flagellar gene that encodes a putative GTP-binding protein. *Mol Microbiol* **6**: 2705–2713.
- Chadsey, M.S., Karlinsey, J.E., and Hughes, K.T. (1998) The flagellar anti-σ factor FlgM actively dissociates *Salmonella*

- typhimurium* σ^{28} RNA polymerase holoenzyme. *Genes Dev* **12**: 3123–3136.
- Colland, F., Rain, J.-C., Gounon, P., Labigne, A., Legrain, P., and De Reuse, H. (2001) Identification of the *Helicobacter pylori* anti- σ^{28} factor. *Mol Microbiol* **41**: 477–487.
- Figurski, D.H., and Helinski, D.R. (1979) Replication of an origin-containing derivative of plasmid RK2 dependent on a plasmid function provided *in trans*. *Proc Natl Acad Sci USA* **76**: 1648–1652.
- Gillen, K.L., and Hughes, K.T. (1991) Molecular characterization of *flgM*, a gene encoding a negative regulator of flagellin synthesis in *Salmonella typhimurium*. *J Bacteriol* **173**: 6453–6459.
- Golden, N.J., and Acheson, D.W.K. (2002) Identification of motility and autoagglutination *Campylobacter jejuni* mutants by random transposon mutagenesis. *Infect Immun* **70**: 1761–1771.
- Grant, C.C.R., Konkol, M.E., Cieplak, W., Jr, and Tompkins, L.S. (1993) Role of flagella in adherence, internalization, and translocation of *Campylobacter jejuni* in nonpolarized and polarized epithelial cell cultures. *Infect Immun* **61**: 1764–1771.
- Guerry, P., Logan, S.M., Thornton, S., and Trust, T.J. (1990) Genomic organization and expression of *Campylobacter* flagellin genes. *J Bacteriol* **172**: 1853–1860.
- Guerry, P., Alm, R.A., Power, M.E., Logan, S.M., and Trust, T.J. (1991) Role of two flagellin genes in *Campylobacter* motility. *J Bacteriol* **173**: 4757–4764.
- Guerry, P., Yao, R., Alm, R.A., Burr, D.H., and Trust, T.J. (1994) Systems of experimental genetics for *Campylobacter* species. *Methods Enzymol* **235**: 474–481.
- Henderson, M.J., and Milazzo, F.H. (1979) Arylsulfatase in *Salmonella typhimurium*: detection and influence of carbon source and tyramine on its synthesis. *J Bacteriol* **139**: 80–87.
- Hendrixson, D.R., Akerley, B.J., and DiRita, V.J. (2001) Transposon mutagenesis of *Campylobacter jejuni* identifies a bipartite energy taxis system required for motility. *Mol Microbiol* **40**: 214–224.
- Higgins, D.E., and DiRita, V.J. (1994) Transcriptional control of *toxT*, a regulatory gene in the ToxR regulon of *Vibrio cholerae*. *Mol Microbiol* **14**: 17–29.
- Higuchi, R. (1990) Recombinant PCR. In *PCR Protocols: a Guide to Methods and Applications*. Innis, M.A., Gelfrand, D.H., Sninsky, J.J., and White, T.J. (eds). London: Academic Press, pp. 177–183.
- Hughes, K.T., Gillen, K.L., Semon, M.J., and Karlinsey, J.E. (1993) Sensing structural intermediates in bacterial flagellar assembly by export of a negative regulator. *Science* **262**: 1277–1280.
- Jagannathan, A., Constantinidou, C., and Penn, C.W. (2001) Roles of *rpoN*, *fliA*, and *flgR* in expression of flagella in *Campylobacter jejuni*. *J Bacteriol* **183**: 2937–2942.
- Josenshans, C., Niehus, E., Amersbach, S., Hörster, A., Betz, C., Drescher, B., *et al.* (2002) Functional characterization of the antagonistic flagellar late regulators FliA and FlgM of *Helicobacter pylori* and their effects on the *H. pylori* transcriptome. *Mol Microbiol* **43**: 307–322.
- Jyot, J., Dasgupta, N., and Ramphal, R. (2002) FleQ, the major flagellar gene regulator in *Pseudomonas aeruginosa*, binds to enhancer sites located either upstream or atypically downstream of the RpoN binding site. *J Bacteriol* **184**: 5251–5260.
- Karlinsey, J.E., Tanaka, S., Bettenworth, V., Yamaguchi, S., Boos, W., Aizawa, S.-I., and Hughes, K.T. (2000) Completion of the hook-basal body complex of the *Salmonella typhimurium* flagellum is coupled to FlgM secretion and *fliC* transcription. *Mol Microbiol* **37**: 1220–1231.
- Karlyshev, A.V., Linton, D., Gregson, N.A., and Wren, B.W. (2002) A novel paralogous gene family involved in phase-variable flagella-mediated motility in *Campylobacter jejuni*. *Microbiology* **148**: 473–480.
- Kim, Y.-K., and McCarter, L.L. (2000) Analysis of the polar flagellar gene system of *Vibrio parahaemolyticus*. *J Bacteriol* **182**: 3693–3704.
- Kinsella, N., Guerry, P., Cooney, J., and Trust, T.J. (1997) The *flgE* gene of *Campylobacter coli* is under the control of the alternative sigma factor σ^{54} . *J Bacteriol* **179**: 4647–4653.
- Klose, K.E., and Mekalanos, J.J. (1998a) Differential regulation of multiple flagellins in *Vibrio cholerae*. *J Bacteriol* **180**: 303–316.
- Klose, K.E., and Mekalanos, J.J. (1998b) Distinct roles of an alternative sigma factor during both free-swimming and colonizing phases of the *Vibrio cholerae* pathogenic cycle. *Mol Microbiol* **28**: 501–520.
- Kutsukake, K., and Iino, T. (1994) Role of the FliA-FlgM regulatory system on the transcriptional control of the flagellar regulon and flagellar formation in *Salmonella typhimurium*. *J Bacteriol* **176**: 3598–3605.
- Kutsukake, K., Ohya, Y., and Iino, T. (1990) Transcriptional analysis of the flagellar regulon of *Salmonella typhimurium*. *J Bacteriol* **172**: 741–747.
- Labigne-Roussel, A., Courcoux, P., and Tompkins, L. (1988) Gene disruption and replacement as a feasible approach for mutagenesis of *Campylobacter jejuni*. *J Bacteriol* **170**: 1704–1708.
- Lüneberg, E., Glenn-Calvo, E., Hartmann, M., Bar, W., and Frosch, M. (1998) The central, surface-exposed region of the flagellar hook protein FlgE of *Campylobacter jejuni* shows hypervariability among strains. *J Bacteriol* **180**: 3711–3714.
- Macnab, R.M. (1996) Flagella and motility. In *Escherichia coli and Salmonella: Cellular and Molecular Biology*, 2nd edn. Neidhardt, F.C., Curtis, R., III, Ingraham, J.L., Lin, E.C.C., Low, K.B., Magasanik, B., *et al.* (eds). Washington, DC: American Society for Microbiology Press, pp. 123–145.
- Makarova, O., Kamberov, E., and Margolis, B. (2000) Generation of deletion and point mutations with one primer in a single cloning step. *Biotechniques* **29**: 970–972.
- Matz, C., van Vliet, A.H.M., Ketley, J.M., and Penn, C.W. (2002) Mutational and transcriptional analysis of the *Campylobacter jejuni* flagellar biosynthesis gene *flhB*. *Microbiology* **148**: 1679–1685.
- Minamino, T., and Macnab, R.M. (1999) Components of the *Salmonella* flagellar export apparatus and classification of export substrates. *J Bacteriol* **181**: 1388–1394.
- Nachamkin, I., Yang, X.-H., and Stern, N.J. (1993) Role of *Campylobacter jejuni* flagella as colonization factors of three-day-old chicks: analysis with flagellar mutants. *Appl Environ Microbiol* **59**: 1269–1273.
- Nuijten, P.J.M., van Asten, F.J.A.M., Gaastra, W., and van

- der Zeijst, B.A.M. (1990) Structural and functional analysis of two *Campylobacter jejuni* flagellin genes. *J Biol Chem* **265**: 17798–17804.
- O'Toole, P.W., Kostrzynska, M., and Trust, T.J. (1994) Non-motile mutants of *Helicobacter pylori* and *Helicobacter mustelae* defective in flagellar hook production. *Mol Microbiol* **14**: 691–703.
- Ochman, H., Gerber, A.S., and Hartl, D.L. (1988) Genetic application of an inverse polymerase chain reaction. *Genetics* **120**: 621–623.
- Ohnishi, K., Kutsukake, K., Suzuki, H., and Iino, T. (1992) A novel transcriptional regulation mechanism in the flagellar regulon of *Salmonella typhimurium*: an anti-sigma factor inhibits the activity of the flagellum-specific sigma factor, σ^F . *Mol Microbiol* **6**: 3149–3157.
- Pandza, S., Baetens, M., Park, C.H., Au, T., Keyhan, M., and Martin, A. (2000) The G-protein FlhF has a role in polar flagellar placement and general stress response induction in *Pseudomonas putida*. *Mol Microbiol* **36**: 414–423.
- Parkhill, J., Wren, B.W., Mungall, K., Ketley, J.M., Churcher, C., Basham, D., *et al.* (2000) The genome sequence of the food-borne pathogen *Campylobacter jejuni* reveals hyper-variable sequences. *Nature* **403**: 665–668.
- Prouty, M.G., Correa, N.E., and Klose, K.E. (2001) The novel σ^{54} - and σ^{28} -dependent flagellar gene transcription hierarchy of *Vibrio cholerae*. *Mol Microbiol* **39**: 1595–1609.
- Quon, K.C., Marczyński, G.T., and Shapiro, L. (1996) Cell cycle control by an essential bacterial two-component signal transduction protein. *Cell* **84**: 83–93.
- Ramakrishnan, G., Zhao, J.-L., and Newton, A. (1994) Multiple structural proteins are required for both transcriptional activation and negative autoregulation of *Caulobacter crescentus* flagellar genes. *J Bacteriol* **176**: 7587–7600.
- Schmitz, A., Josenhans, C., and Suerbaum, S. (1997) Cloning and characterization of the *Helicobacter pylori* *flbA* gene, which codes for a membrane protein involved in coordinated expression of flagellar genes. *J Bacteriol* **179**: 987–997.
- Spohn, G., and Scarlato, V. (1999) Motility of *Helicobacter pylori* is coordinately regulated by the transcriptional activator FlgR, an NtrC homolog. *J Bacteriol* **181**: 593–599.
- Starnbach, M.N., and Lory, S. (1992) The *fliA* (*rpoF*) gene of *Pseudomonas aeruginosa* encodes an alternative sigma factor required for flagellin synthesis. *Mol Microbiol* **6**: 459–469.
- Stock, A.M., Robinson, V.L., and Goudreau, P.N. (2000) Two-component signal transduction. *Annu Rev Biochem* **69**: 183–215.
- Totten, P.A., Lara, J.C., and Lory, S. (1990) The *rpoN* gene product of *Pseudomonas aeruginosa* is required for expression of diverse genes, including the flagellin gene. *J Bacteriol* **172**: 389–396.
- van Vliet, A.H.M., Wood, A.C., Henderson, J., Wooldridge, K., and Ketley, J.M. (1997) Genetic manipulation of enteric *Campylobacter* species. *Methods Microbiol* **27**: 407–419.
- van Vliet, A.H., Baillon, M.A., Penn, C.W., and Ketley, J.M. (2001) The iron-induced ferredoxin FdxA of *Campylobacter jejuni* is involved in aerotolerance. *FEMS Microbiol Lett* **196**: 189–193.
- Wassenaar, T.M., Bleumink-Pluym, N.M.C., and van der Zeijst, B.A.M. (1991) Inactivation of *Campylobacter jejuni* flagellin genes by homologous recombination demonstrates that *flaA* but not *flaB* is required for invasion. *EMBO J* **10**: 2055–2061.
- Wassenaar, T.M., van der Zeijst, B.A.M., Ayling, R., and Newell, D.G. (1993) Colonization of chicks by motility mutants of *Campylobacter jejuni* demonstrates the importance of flagellin A expression. *J Gen Microbiol* **139**: 1171–1175.
- Wiesner, R.S., Hendrixson, D.R., and DiRita, V.J. (2003) Natural transformation of *Campylobacter jejuni* requires components of a type II secretion system. *J Bacteriol* (in press).
- Wösten, M.M.S.M., Boeve, M., Koot, M.G.A., van Nuenen, A.C., and van der Zeijst, B.A.M. (1998) Identification of *Campylobacter jejuni* promoter sequences. *J Bacteriol* **180**: 594–599.
- Wu, J., and Newton, A. (1997) Regulation of the *Caulobacter* flagellar gene hierarchy; not just for motility. *Mol Microbiol* **24**: 233–239.
- Wu, J., Benson, A., and Newton, A. (1995) Global regulation of a σ^{54} -dependent flagellar gene family in *Caulobacter crescentus* by the transcriptional activator FlbD. *J Bacteriol* **177**: 3241–3250.
- Yao, R., and Guerry, P. (1996) Molecular cloning and site-specific mutagenesis of a gene involved in arylsulfatase production in *Campylobacter jejuni*. *J Bacteriol* **178**: 3335–3338.
- Yao, R., Burr, D.H., Doig, P., Trust, T.J., Niu, H., and Guerry, P. (1994) Isolation of motile and non-motile insertional mutants of *Campylobacter jejuni*: the role of motility in adherence and invasion of eukaryotic cells. *Mol Microbiol* **14**: 883–893.