



Flexible and Cost Efficient Power Consumption using Economic MPC A Supermarket Refrigeration Benchmark

Hovgaard, Tobias Gybel; Larsen, Lars F.S.; Jørgensen, John Bagterp

Published in:

Proceedings of the 50th IEEE Conference on Decision and Control and European Control Conference

Link to article, DOI:

[10.1109/CDC.2011.6161162](https://doi.org/10.1109/CDC.2011.6161162)

Publication date:

2011

Document Version

Publisher's PDF, also known as Version of record

[Link back to DTU Orbit](#)

Citation (APA):

Hovgaard, T. G., Larsen, L. F. S., & Jørgensen, J. B. (2011). Flexible and Cost Efficient Power Consumption using Economic MPC: A Supermarket Refrigeration Benchmark. In *Proceedings of the 50th IEEE Conference on Decision and Control and European Control Conference* (pp. 848-854). IEEE.
<https://doi.org/10.1109/CDC.2011.6161162>

General rights

Copyright and moral rights for the publications made accessible in the public portal are retained by the authors and/or other copyright owners and it is a condition of accessing publications that users recognise and abide by the legal requirements associated with these rights.

- Users may download and print one copy of any publication from the public portal for the purpose of private study or research.
- You may not further distribute the material or use it for any profit-making activity or commercial gain
- You may freely distribute the URL identifying the publication in the public portal

If you believe that this document breaches copyright please contact us providing details, and we will remove access to the work immediately and investigate your claim.

Flexible and Cost Efficient Power Consumption using Economic MPC A Supermarket Refrigeration Benchmark

Tobias Gybel Hovgaard, Lars F. S. Larsen and John Bagterp Jørgensen

Abstract—Supermarket refrigeration consumes substantial amounts of energy. However due to the thermal capacity of the refrigerated goods, parts of the cooling capacity delivered can be shifted in time without deteriorating the food quality. In this paper we introduce a novel economic-optimizing MPC scheme that reduces operating costs by utilizing the thermal storage capabilities. In the study we specifically address advantages coming from daily variations in outdoor temperature and electricity prices but other aspects such as peak load reduction are also considered. An important contribution of this paper is also the formulation of a new cost function for our proposed power management system. This means the refrigeration system is enabled to contribute with ancillary services to the balancing power market. Since significant amounts of regulating power are needed for a higher penetration of intermittent renewable energy sources such as wind turbines, this feature will be in high demand in a future intelligent power grid (Smart Grid). Our perspective is seen from the refrigeration system but, as we demonstrate, the involvement in the balancing market can be economically beneficial for the system itself, while delivering crucial services to the Smart Grid. We simulate the system using models validated against data from real supermarkets as well as weather data and spot and regulating power prices from the Nordic power market.

I. INTRODUCTION

In Denmark around 4500 supermarkets consume more than 550,000 MWh annually. This corresponds roughly to 2% of the entire electricity consumption. The installed cooling capacity equals an electrical wattage ranging from 10 to 200 kW depending on the supermarket size. The refrigerated goods make up a large capacity in which energy can be stored in the form of "coldness". Due to the simple hysteresis control policy most commonly used today, a large unexploited potential for energy and cost reductions exists. Preliminary investigations have been carried out in [1], [2], and in this paper we further analyse this in a realistic setting. Furthermore a novel formulation of the cost function enables the supermarket refrigeration system to benefit from the enablement of flexible power consumption.

To obtain an increasing amount of electricity from intermittent energy sources such as solar and wind, we must not only control the production of electricity but also the consumption of electricity in an efficient, flexible and proactive manner. In contrast to the current rather centralized power generation system, the future electricity

grid will be a network of a very large number of independent power generators. The Smart Grid is the future intelligent electricity grid and is intended to be the smart electrical infrastructure required to increase the amount of green energy significantly. The Danish transmission system operator (TSO) has the following definition of Smart Grids which we adopt in this work: "Intelligent electrical systems that can integrate the behavior and actions of all connected users - those who produce, those who consume and those who do both - in order to provide a sustainable, economical and reliable electricity supply efficiently" [3]. In this paper we utilize the flexibility of the refrigeration system to offer ancillary demand response to the power grid as regulating power. Different means of utilizing demand response have been investigated in an increasing number of publications e.g. [4]–[7] for plug-in electrical vehicles and heat pumps and in general concerning price elasticity in [8].

Our proposed control strategy is an economic optimizing model predictive controller, economic MPC. Predictive control for constrained systems has emerged during the last 30 years as one of the most successful methodologies for control of industrial processes [9] and is increasingly being considered to control both refrigeration and power systems [10], [11]. MPC based on optimizing economic objectives has only recently emerged as a general methodology with efficient numerical implementations and provable stability properties [12]–[14]. We have previously introduced economic MPC in [15] to control a power management scheme for large power consumers such as supermarket refrigeration systems. The economic MPC has the ability to adjust the power consumption profile to the power supply. The thermal capacity is utilized to shift the load in time, while keeping the temperatures within certain bounds. These bounds are chosen such that they have no impact on food quality. We exploit the fact that the dynamics of the temperature in the cold room are rather slow, while the power consumption can be changed rapidly. Utilizing load shifting capabilities to reduce total energy consumption has also been described in e.g. [16]–[18]. In the simulations that will be presented in this paper, we use models, parameters and temperatures verified against data logged from real supermarkets, along with electricity prices from the NordPool spot market.

Our cost function is nonlinear in the control variables but instead of doing any simplification we have chosen a nonlinear solver [19] to run the simulations. The proposed

T. G. Hovgaard and L. F. S. Larsen are with Danfoss Refrigeration and A/C Controls, DK-6430 Nordborg, Denmark. {tgh, lars.larsen}@danfoss.com

J. B. Jørgensen is with DTU Informatics, Technical University of Denmark, DK-2800 Lyngby, Denmark. jbj@imm.dtu.dk

nonlinear economic MPC algorithm is not tractable for industrial hardware with limited computational resources. Hence, the contribution of this paper is to illustrate the optimal solution and potential of our approach. The study is therefore suitable for benchmarking future, more appealing algorithms. However it should be kept in mind, that the slow dynamics of the system allow for long sample times and therefore, increased complexity of the controller. Robustifying against uncertainties in predictions and models as in [20] also degrades the cost reductions and the study in this paper is again useful for quantifying this kind of effect.

This paper is organized as follows. Section II describes the physics and models used for the supermarket refrigeration systems as well as the thermal storage capabilities. In section III we formulate the economic MPC controller and in section IV the calculations needed for regulating power are given. The scenario for a realistic simulation and the corresponding results are presented in section V and in section VI we give conclusions.

II. SUPERMARKET REFRIGERATION

The supermarket refrigeration systems we consider utilize a vapor compression cycle where a refrigerant is circulated in a closed loop consisting of a compressor, an expansion valve and two heat exchangers, an evaporator in the cold storage room as well as a condenser/gas cooler located in the surroundings. When the refrigerant evaporates, it absorbs heat from the cold reservoir which is rejected to the hot reservoir. The setup is sketched in Fig. 1 with one cold storage room and one frost room connected to the system. Usually several cold storage rooms, e.g. display cases, are connected to a common compressor rack and condensing unit. Hence, the individual display cases see the same evaporation temperature whereas each unit has its own inlet valve for individual temperature control.

A. Models

The dynamics in the cold room can be described by a simple energy balance:

$$m c_p \frac{dT_{cr}}{dt} = \dot{Q}_{load} - \dot{Q}_e \quad (1)$$

with

$$\dot{Q}_{load} = (UA)_{amb-cr} \cdot (T_{amb} - T_{cr}) \quad (2a)$$

$$\dot{Q}_e = (UA)_{cr-e} \cdot (T_{cr} - T_e) \quad (2b)$$

where UA is the heat transfer coefficient and m and c_p are the mass and the specific heat capacity of the refrigerated goods, respectively. T_{amb} is the temperature of the ambient air which puts the heat load on the refrigeration system. The states and control variables of the system are limited by the following constraints:

$$T_{cr,min} \leq T_{cr} \leq T_{cr,max} \quad (3a)$$

$$0 \leq T_{cr} - T_e \leq \infty \quad (3b)$$

$$0 \leq \dot{Q}_e \leq (UA)_{cr-e,max} \cdot (T_{cr} - T_e) \quad (3c)$$

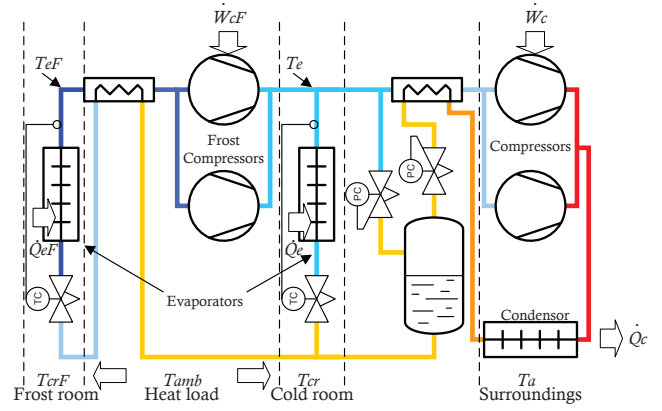

Fig. 1. Schematic layout of basic refrigeration system.

We define the set Ω as all (\dot{Q}_e, T_e) that satisfy the system dynamics (Eq. (1)) and the constraints given in Eq. (3).

The work done by the compressor dominates the power consumption in the system and can be expressed by the mass flow of refrigerant (m_{ref}) and the change in energy content of the refrigerant. Energy content is described by the enthalpy of the refrigerant at the inlet and at the outlet of the compressor (h_{ic} and h_{oc} respectively). Hereby the expression in Eq. (4) is given.

$$\dot{W}_c = \frac{m_{ref} \cdot (h_{oc}(T_e, P_c) - h_{ic}(T_e))}{\eta_{is}(P_c/P_e)} \quad (4)$$

where the enthalpies depend on the evaporation temperature and the condensing pressure, as stated. The mass flow can be determined as the ratio between cooling capacity and change of enthalpy over the evaporator:

$$m_{ref} = \frac{\dot{Q}_e}{h_{oe}(T_e) - h_{ie}(P_c)} \quad (5)$$

All the enthalpies given here as functions of T_e , P_c or both are non-linear refrigerant dependent functions which can be calculated e.g. by the software package "RefEqns" [21].

In the sequel, we adopt the approximation used for \dot{W}_c in [2], where polynomials are fitted for the enthalpy differences and the isentropic efficiency, η_{is} , is assumed constant within the range of operation. When a frost room is included, an extra compressor system is usually added between the frost evaporator and the suction side of the other compressors. This compressor decreases the evaporation temperature for the frost part of the system to a lower level. The work in the frost compressor is similar to what we have already described, but instead of the condensing temperature, the frost compressor sees the evaporation temperature for the cooling part at its outlet. The mass flow through the frost compressor needs to be added to the flow through the compressors from the cooling. We use the subscript F to denote variables related to the frost part.

For the studies in this paper we have collected data from several supermarkets actually in operation in Denmark. From

these data, typical parameters such as time constants, heat loads, temperature ranges and capacities in both individual display cases and for the overall system have been estimated for both horizontal display cases, vertical shelving units and frost rooms. Furthermore the running compressor capacity has been monitored and from the data sheets the relation to energy consumption has been found.

B. Thermal Storage

Today, most display cases and cold rooms in supermarkets are controlled by hysteresis. Thus, maximum cooling is applied when the cold room temperature reaches an upper limit and shut off when the lower limit is reached. This control policy does not exploit the thermal capacity in the refrigerated mass and energy is consumed when it is needed instead of when it is more favorable. Several factors can, however, make it beneficial to shift the load. These include variations in outdoor temperature, fluctuating energy prices, times for restocking and night covers. Obviously several unexploited potentials exist. If peak loads can be predicted, pre-cooling can be applied such that the stored coldness helps reduce the demand at the peak time. Thereby, the entire system might be dimensioned differently, which saves money both in the installation phase and during operation. By moving part of the cooling capacity to the colder night times, overall energy consumption can be reduced since the work done by the compressor to obtain a certain evaporation temperature is dependent on the pressure difference which again depends on the temperature surrounding the condenser. In contrast, shifting loads according to fluctuations in electricity prices actually make the system consume more energy. Thus, the profitability rests upon the extra heat loss during periods when extra coldness is stored in the system is at least counterbalanced by the difference in electricity price.

It is evident from the discussion above that the potential in load shifting in large part depends on both the thermal capacity and the differences in electricity prices and outdoor temperatures. However, the rate of change of these parameters in comparison with the time constants of the cold room temperatures also plays an important role.

III. ECONOMIC MPC SETUP

A supermarket refrigeration system is influenced by a number of disturbances that can be predicted to some degree of certainty over a time horizon into the future. The controller also has to obey certain constraints for the systems, while minimizing the cost of operation. Thus, we find it reasonable to aim at formulating our controller as an economic optimizing MPC problem. Whereas the cost function in MPC traditionally penalizes a deviation from a set-point, our proposed economic MPC directly reflects the actual costs of operating the plant. This formulation is tractable for refrigeration systems where we are interested in keeping the outputs (cold room temperatures)

within certain ranges, while minimizing the cost of doing so.

Like in traditional MPC, we implement the controller in a receding horizon manner where an optimization problem over N time steps (our control and prediction horizon) is solved at each sample. The result is an optimal input sequence for the entire horizon out of which only the first step is implemented. This procedure is repeated at each sample. The objective function is the cost of operation which in this case is entirely related to electricity consumption. We do not aim specifically at minimizing the energy consumption, nor do we focus on tracking certain temperatures in the cold rooms. The optimization problem is thus formulated as:

$$\min_{(\dot{\mathbf{Q}}_e, \mathbf{T}_e) \in \Omega} \Phi = \sum_{k=0}^{N-1} C_{el,k} W_c(\dot{Q}_{e,k}, T_{e,k}, T_{a,k}, T_{amb,k}) \quad (6a)$$

$$\dot{\mathbf{Q}}_e = \left\{ \dot{Q}_{e,k} \right\}_{k=0}^{N-1}, \quad \mathbf{T}_e = \left\{ T_{e,k} \right\}_{k=0}^{N-1} \quad (6b)$$

where $W_c(\cdot)$ is the energy consumption as in section II. The MPC feedback law is the first move in Eq. (6b).

Often output constraints are soft in MPC but in this setup constraints on temperatures and capacity are made hard. In reality one could formulate a cost on cold room temperatures outside the allowable range related to the degrading of the food stuff. This cost would then be the cost on slack variables in a soft constraint. However, firstly it is not realistic that an owner of a refrigeration system will damage the food stuff, and secondly, estimating bacteria growth in refrigerated food is, in itself, a complicated study. In a stochastic formulation a feasible problem can be guaranteed using probabilistic constraints.

In the above formulation we assume perfect predictions and therefore we allow the system to go to any extreme point within the feasible region. However in reality both disturbance predictions and models of the systems are subject to uncertainties that are prone to driving the otherwise optimal solution of the economic MPC to a very undesirable solution. For refrigeration systems, such situations could be too high or too low temperatures in the cold room damaging the food stuff; emergency shut down of systems due to maximum capacity being exceeded; penalties for not fulfilling regulating power agreements or unnecessarily high operation costs. Consequently we have formulated a robust economic MPC scheme in [20] using probabilistic constraints and assumed knowledge of the probability density functions for stochastic disturbances and impulse response coefficients of the system models.

IV. FLEXIBLE POWER CONSUMPTION

In order to ensure a sustainable physical balance in the electricity system, there is a need for regulating power and various types of spare capacity. Spare capacity is production capacity or consumption made available in advance to the

TSO by parties responsible for maintaining balance in the system, in return for an availability payment. Various types of spare capacity exist. These types of capacity differ in activating velocity, amount and demands for the upholding period.

With the enablement of flexible consumption in refrigeration systems we are ready to consider other incentives to load shifting than those already mentioned in section II. In this section we formulate a framework in which the supermarkets can participate in the primary reserve (the capacity with fastest activation and shortest upholding periods).

A. Up regulating power as primary reserve:

Up regulating power is increased production or reduced consumption. Each player participates with a power amount (MW) specified on an hourly basis and is paid for making the power available to the grid (DKK/MW) regardless of the actual activation. Activation is automatic and linearly frequency dependent in the range $\pm 200\text{mHz}$. Activation is maintained for up to 15 minutes (typically 2-3 minutes) and must be fully restored after 15 minutes. Even though the activated power (MW) might be large, the delivered energy (MWh) is usually small amounts, so a possible change in spot price during the activation will have almost no effect on the economy.

Assumption 1: Since the ambient temperature is generally much higher than the cold room temperature, the small change in temperature during an activation does not change the load, $\dot{Q}_{load} = UA(T_{amb} - T_{cr})$ much. Hence, by assuming that $\dot{Q}_{load} = UA(T_{amb} - T_{cr,start})$ is constant over the activation period we are almost conservative in the calculations.

Assumption 2: In steady state $\dot{Q}_e = \dot{Q}_{load}$

Assumption 3: An activation period of maximum 15 minutes is relatively short compared to the rate of change in the disturbances (Outdoor temperature T_a and electricity spot prices C_{el}). Thus, the cost of the energy required to reestablish the reserve following an activation is approximately the same as the amount saved during the activation.

The amount of power available for up regulation is described by:

$$\dot{Q}_{reg\div} = \dot{Q}_e - \dot{Q}_{15\div} \quad (7)$$

where $\dot{Q}_{reg\div}$ is the cooling capacity that can be released as up regulating power and $\dot{Q}_{15\div}$ is the cooling need in order to make T_{cr} stay below $T_{cr,max}$ for 15 minutes. During an activation the temperature in the cold room is:

$$m \cdot Cp \frac{dT_{cr}}{dt} = \dot{Q}_{load} - \dot{Q}_{15\div} = \dot{Q}_{reg\div} \quad (8)$$

Therefore:

$$m \cdot Cp \int_{T_{cr}}^{T_{cr,max}} dT_{cr} = \int_0^{900s} \dot{Q}_{reg\div} dt \quad (9)$$

$$\dot{Q}_{reg\div} = (T_{cr,max} - T_{cr}) \frac{m \cdot Cp}{900s} \quad (10)$$

For up regulating power there is a potential decrease in heat loss from the system if the reserve is activated. By assuming almost linear cold room temperature curves within the range we are considering for regulating power reserves, the reduced energy loss during an entire period of activation and the subsequent re-establishment can be averaged by

$$\dot{Q}_{loss\div} = P_{\div} \cdot \alpha_{\div} \cdot UA \cdot (T_{cr,max} - T_{cr}) \quad (11)$$

where UA is the overall heat transfer coefficient from the cold room to surroundings and P_{\div} is the probability of being activated (samples where the system is activated as up regulating power or is re-establishing after an up regulation versus the total number of samples). We also introduce a new decision variable $\alpha_{\div} \in [0; 1]$, which is the amount of available up regulating power that is actually offered to the grid. Since power cannot be extracted from the stored coldness we have to introduce a constraint such that the offered up regulating power is never larger than the actual power consumption at any point of time.

$$\alpha_{\div} \cdot \dot{Q}_{reg\div} \leq \dot{Q}_e \quad (12)$$

B. Down regulating power as primary reserve:

Down regulating power is reduced production or increased consumption. The rules of participation are equal to those described for up regulating power. The assumptions 1-3 are still in effect, however assumption 3 is the opposite. Namely that the cost of extra energy used during an activation equals the amount that can be saved following the activation.

The system can participate with down regulating power as given by:

$$\dot{Q}_{reg+} = \dot{Q}_{15+} - \dot{Q}_e \quad (13)$$

where \dot{Q}_{reg+} is the extra cooling capacity that can be used as down regulating power and \dot{Q}_{15+} is the cooling capacity that makes T_{cr} go to $T_{cr,min}$ in 15 minutes. Performing the same calculations as in Eq. (8)-(9) yields:

$$\dot{Q}_{reg+} = (T_{cr} - T_{cr,min}) \frac{m \cdot Cp}{900s} \quad (14)$$

As with up regulating power, an activation of the reserve changes the heat loss from the system. This is not accounted for in the calculations above. Whereas the original cost function covers the extra heat loss caused by maintaining up regulating reserves (a decrease in cold room temperature and thereby increase in heat loss in time periods with no activation) there is no extra cost, in terms of heat loss, related to maintaining down regulating reserves. This cost only comes into play when activation occurs. Again, we assume almost linear temperature curves within the range of interest and the energy loss during an entire period of activation and subsequent re-establishment can be averaged by

$$\dot{Q}_{loss+} = P_{+} \cdot \alpha_{+} \cdot UA \cdot (T_{cr} - T_{cr,min}) \quad (15)$$

where P_{+} is the probability of being activated. A new decision variable, $\alpha_{+} \in [0; 1]$, is again introduced describing

the share of available down regulating power that is actually offered to the grid. The amount of down regulating power offered must be bounded such that the sum of current cooling capacity and that offered for down regulation does not exceed the maximum capacity of the system. Thus, even on a hot summer day the following has to be fulfilled:

$$\alpha_+ \cdot \dot{Q}_{reg+} + \dot{Q}_e \leq \dot{Q}_{max} \quad (16)$$

C. Cost Function

We are now able to formulate a cost function including the effects of regulating power:

$$\begin{aligned} \min_{\dot{Q}_e, \mathbf{T}_e, \alpha_+, \alpha_+} \sum_{k=0}^N & \left[C_{elk} W_k((\dot{Q}_{e,k} - \dot{Q}_{loss+,k} + \dot{Q}_{loss+,k}), (\cdot)) \right. \\ & - C_{upregk} W_k(\alpha_+, k \dot{Q}_{reg+,k}, (\cdot)) \\ & \left. - C_{downregk} W_k(\alpha_+, k \cdot \dot{Q}_{reg+,k}, (\cdot)) \right] \\ \text{s.t.} & \\ & (\dot{Q}_e, \mathbf{T}_e) \in \Omega \\ & \text{Eq. (12)} \\ & \text{Eq. (16)} \end{aligned} \quad (17)$$

where ' \cdot ' indicates the remaining parameters from Eq. (6a).

V. RESULTS

In this section we present the conditions used for simulating a realistic scenario with the supermarket refrigeration system from section II in a setting where predictions of electricity prices, regulating power prices as well as outdoor temperatures exist. We use the economic MPC controller described in section III, and for the regulating power scenarios, the cost function in section IV is employed. Results of the simulations are presented and discussed.

A. Scenario

For the study in this paper we have chosen a supermarket refrigeration system with three units attached. This roughly corresponds in size to between 1/15 to 1/5 of one of the supermarkets we have been monitoring and the capacity of the system has been scaled accordingly. The three units are very different. The shelving unit is usually used for smaller items like sliced meat and does not hold a very large mass of food stuff. The heat load is relatively high due to the large vertical opening to the surroundings. The chest display case holds larger amounts of e.g. minced meat and due to the horizontal opening, which also has a glass cover, the heat load is rather low. The frost room with insulated walls on all sides has the lowest heat load and the mass of frozen meat contained is large. For the frost room an extra compressor is added, lowering the evaporation temperature to a sufficiently lower level than the evaporation temperature in the cooling units. All three units have different demands to temperature, namely $[2; 4]^\circ\text{C}$ for the shelving unit, $[1; 5]^\circ\text{C}$ for the chest display case and $[-25; -15]^\circ\text{C}$ for the frost room. The models were validated

with running supermarkets in Denmark in January 2011. Electricity prices were downloaded from NordPool's hourly el-spot price for a period of one month. There is a clear trend in these data for each 24-hour period. Therefore, for each hour of the day, the average has been found and this 24-hour signal was used for the electricity price. The same was done with the availability payment for regulating power.

Temperature readings from Danish Meteorological Institute covering the same period were obtained. It has been found that by low pass filtering and detrending these data, the intra-day variations can be closely approximated by a sinusoid with a 24-hour period and a phase shift such that it peaks a couple of hours after noon. The amplitude for this period has been chosen to 3°C .

We divide our simulations into two scenarios. One that illustrates the effect of variations in electricity prices and temperatures, and one that shows how regulating power services can be offered. Simulations are performed over at least 24 hours. An issue with MPC is that the long prediction horizons tend to make the problems computationally hard. However, due to the slow dynamics of the refrigeration system, we have chosen a sampling time of 32 minutes. Thus a prediction horizon of 16 hours is implemented with just $N = 30$ samples.

B. Simulation

Fig. 2 shows the simulated refrigeration system using the predicted outdoor temperature and electricity price to optimize the cost. The amplitude of the electricity price has been multiplied by four to better illustrate the effect and to reflect a scenario with variable taxes instead of the flat rate fees seen today. This is discussed in the next section. In this case the cost savings amount to 32%. If the original electricity price is used, less change in cold room temperatures can be observed and the cost savings amount to 9% in this case. With three quarters of the electricity price paid in Denmark today being flat rate taxes and fees, saving 9% on the spot price corresponds to 2.25% of the entire electricity bill. If we are only exploiting the variations in outdoor temperature, the economic MPC control scheme saves around 2% of the energy consumption.

In Fig. 3 the effect of participating in the power balancing market is simulated for a selected scenario of availability payments. In this simulation the outdoor temperature is assumed constant in order to illustrate the effect of availability payments for regulation power versus the electricity spot price as clearly as possible. This simulation reveals an additional saving of up to 70% compared to the case where only the electricity spot price is used for optimization (approximately 30% for up regulation only).

C. Discussion

From the results illustrated in Fig. 2 we can conclude that the proposed economic MPC scheme has a positive effect

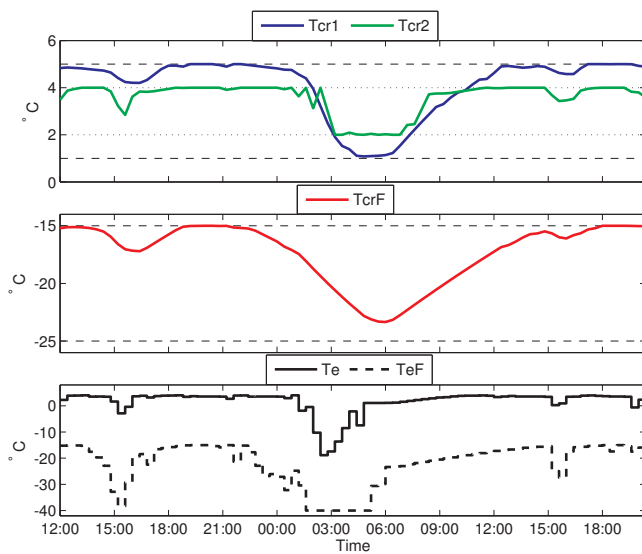

(a) Cold room and evaporation temperatures

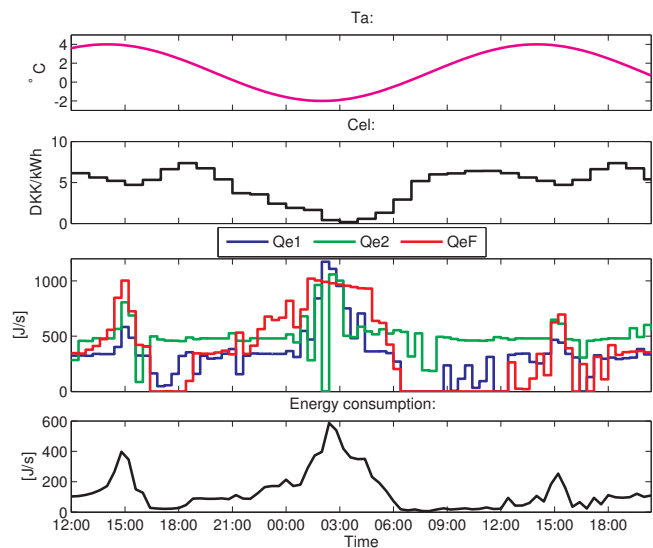

(b) Disturbances, Cooling powers and Energy consumption.

Fig. 2. Simulation showing how variations in outdoor temperature and electricity prices are exploited by utilization of thermal storage.

on the costs related to operating the supermarket. Variations in outdoor temperature are utilized to minimize power consumption, whereas exploiting variations in electricity prices tends to increase overall power consumption but at a lower cost. In Fig. 2 the amplitude of the electricity price has been multiplied by four to illustrate the increase in effect gained by the power management. Today the dominant part of the price paid for electricity consists of taxes and connection fees, which are all paid as flat rate charges per MWh. This blurs the price signals from the market to the users and reduces the incentives to react to such signals. Hence, the simulation shown above with four-times amplitude on the el-spot price is an attempt to model a situation where the taxes and other fees are charged as a percentage of the actual el-spot price. This would result in a magnification instead of a smoothing of the market signals.

Obviously the flexibility is drastically reduced if the system is running near its maximum capacity just to keep the temperatures below the maximum limits on a hot summer day. It is not possible to increase consumption, whether it be for storing coldness or for down regulation due to the maximum capacity; nor is it possible to decrease consumption, since this would violate the temperature demands in the cold rooms. This situation leads to a trade-off between saving by dimensioning a smaller system when peak loads can be reduced as described in section II and savings related to flexible consumption and regulating power.

Participating in the balancing power market also seems to be beneficial for both the power system and the supermarkets if we consider the simulation in Fig. 3. At least at the time of the year/day where extra capacity is available and the availability payment is sufficiently high. The availability

payments are observed to vary more from day to day than the spot prices. Hence, the simulation presented in this paper is just for a selected scenario. However a large potential saving has been found, meaning that there is room for deviations from the simulated scenario without ruining the business case of participating with regulating power. Furthermore it is estimated from the simulations that a supermarket can offer at least 20% of its capacity as regulating power (except at the peak load days of the year). Currently the peak demand in Denmark for primary reserves is around 60MW. With an average supermarket offering about 20 percent of its capacity, approximately 75 percent of the total needs for primary reserves could be provided by supermarkets. A single supermarket is not able to participate with sufficient capacities to place bids on the balancing market, however aggregation of e.g. chains of shops would be an obvious solution. With an increasing penetration of intermittent wind energy, the value of regulating reserves is expected to increase [22]. Thus, not only the need for regulating power but also the incentives to participate in the regulating power market increase.

VI. CONCLUSION

We have presented a power management scheme for a supermarket refrigeration system and demonstrated how an economic MPC control policy can reduce operating costs of the system. Models, parameters and other quantities used have been verified and are to scale with realistic scenarios in Denmark. Using a nonlinear MPC solver for our problem we illustrated that significant savings of up to 9-32% can be achieved by utilizing thermal storage capacities together with predictions of varying loads and energy prices. A novel formulation of the cost function flexibilities in the power consumption also revealed a potential for participating in the

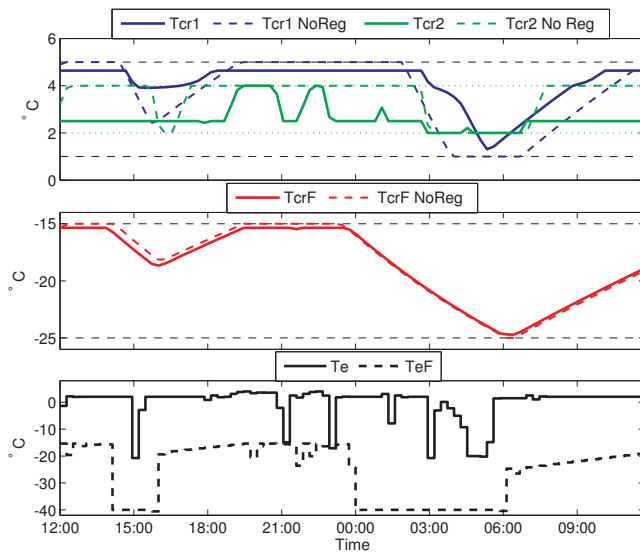

(a) Cold room and evaporation temperatures

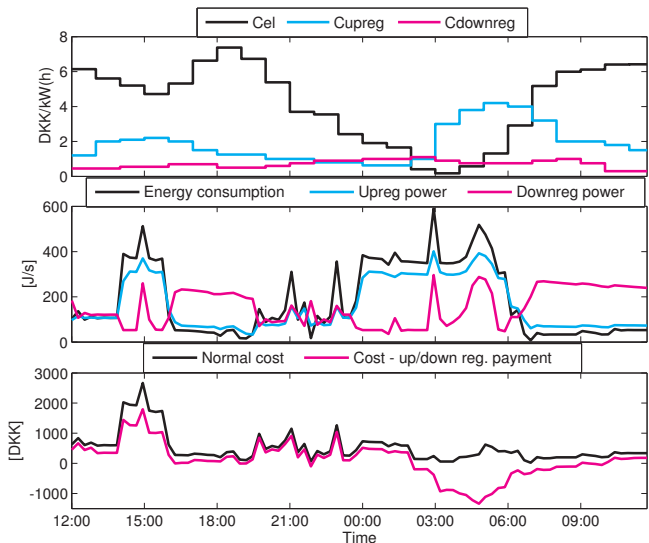

(b) Prices, consumptions and costs.

Fig. 3. Simulation showing how the flexible consumption is utilized for offering regulating power to the balancing market. The cold room temperatures for an optimization utilizing only the electricity spot price over the same period are shown to illustrate the difference.

balancing power market with remarkable cost reductions of up to 70% as the result. The results are especially valuable for proving the concept and the new cost function in a realistic setting, but they are also useful for benchmarking future algorithms that might include computational simplifications and/or implementation of robustifying means in the economic MPC formulation.

REFERENCES

- [1] L. F. S. Larsen, C. Thybo, and H. Rasmussen, "Potential energy savings optimizing the daily operation of refrigeration systems," *Proc. European Control Conference, Kos, Greece*, pp. 4759–4764., 2007.
- [2] T. G. Hovgaard, L. F. S. Larsen, M. J. Skovrup, and J. B. Jørgensen, "Power Consumption in Refrigeration Systems - Modeling for Optimization," in *4th International Symposium on Advanced Control of Industrial Processes, 2011*, 2011, pp. 234–239.
- [3] Energinet.dk, "Potential and opportunities for flexible electricity consumption with special focus on individual heat pumps (in Danish)," Energinet.dk, The Danish TSO owned by the Danish Climate and Energy Ministry., Tech. Rep., 2011.
- [4] S. L. Andersson, A. K. Eloffson, M. D. Galus, L. Göransson, S. Karlsson, F. Johansson, and G. Andersson, "Plug-in hybrid electric vehicles as regulating power providers: Case studies of Sweden and Germany," *Energy policy*, vol. 38, no. 6, pp. 2751–2762, 2010.
- [5] H. Saele and O. S. Grande, "Demand response from household customers: Experiences from a pilot study in norway," *IEEE Transactions on Smart Grid*, vol. 2, no. 1, pp. 90–97, 2011.
- [6] S. Han, S. Han, and K. Sezaki, "Development of an optimal vehicle-to-grid aggregator for frequency regulation," *IEEE Transactions on Smart Grid*, vol. 1, no. 1, pp. 65–72, 2010.
- [7] A. Molina-Garcia, M. Kessler, J. A. Fuentes, and E. Gomez-Lazaro, "Probabilistic characterization of thermostatically controlled loads to model the impact of demand response programs," *IEEE Transactions on Power Systems*, vol. 26, no. 1, pp. 241–251, 2011.
- [8] D. S. Kirschen, "Demand-side view of electricity markets," *Power Systems, IEEE Transactions on*, vol. 18, no. 2, pp. 520–527, 2003.
- [9] S. J. Qin and T. A. Badgwell, "A survey of industrial model predictive control technology," *Control engineering practice*, vol. 11, no. 7, pp. 733–764, 2003.
- [10] D. Sarabia, F. Capraro, L. F. S. Larsen, and C. de Prada, "Hybrid nmpc of supermarket display cases," *Control Engineering Practice*, vol. 17, no. 4, pp. 428–441, 2008.
- [11] K. Edlund, J. D. Bendtsen, and J. B. Jørgensen, "Hierarchical model-based predictive control of a power plant portfolio," *Control Engineering Practice*, p. accepted, 2011.
- [12] D. Angeli, R. Amrit, and J. B. Rawlings, "On average performance and stability of economic model predictive control," *IEEE Transactions on Automatic Control*, p. accepted, 2011.
- [13] M. Diehl, R. Amrit, and J. B. Rawlings, "A Lyapunov Function for Economic Optimizing Model Predictive Control," *IEEE Transactions on Automatic Control*, 2009.
- [14] J. B. Rawlings and R. Amrit, "Optimizing Process Economic Performance Using Model Predictive Control," *Nonlinear Model Predictive Control: Towards New Challenging Applications*, pp. 119–138, 2009.
- [15] T. G. Hovgaard, K. Edlund, and J. B. Jørgensen, "The Potential of Economic MPC for Power Management," in *49th IEEE Conference on Decision and Control, 2010*, 2010, pp. 7533–7538.
- [16] G. L. Van Harmelen, "The virtual power station targeting residential, industrial and commercial controllable loads," *IFAC Conference on Technology Transfer in Developing Countries - Automation in Infrastructure Creation (DECOM-TT 2000) Proceedings volume from IFAC Conference*, pp. 45–48, 2001.
- [17] R. Bush and G. Wolf, "Utilities load shift with thermal storage," *Transmission & Distribution World*, p. 12, 2009.
- [18] F. Oldewurtel, A. Parisio, C. N. Jones, M. Morari, D. Gyalistras, M. Gwerder, V. Stauch, B. Lehmann, and K. Wirth, "Energy Efficient Building Climate Control using Stochastic Model Predictive Control and Weather Predictions," in *Proc. of American Control Conference 2010*, 2010, pp. 5100–5105.
- [19] B. Houska, H. Ferreau, and M. Diehl, "ACADO Toolkit—An Open Source Framework for Automatic Control and Dynamic Optimization," *Optimal Control Applications and Methods*, 2010.
- [20] T. G. Hovgaard, L. F. S. Larsen, and J. B. Jørgensen, "Robust Economic MPC for a Power Management Scenario with Uncertainties," in *50th IEEE Conference on Decision and Control, 2011*, 2011, p. accepted.
- [21] M. J. Skovrup, "Thermodynamic and thermophysical properties of refrigerants - software package in borland delphi." Department of Energy Engineering, Technical University of Denmark, Tech. Rep., 2000.
- [22] S. Meyn, M. Negrete-Pincetic, G. Wang, A. Kowli, and E. Shafiepoor-fard, "The value of volatile resources in electricity markets," in *49th IEEE Conference on Decision and Control, 2010*, 2010, pp. 1029–1036.