

Flipping the head of $T[\text{SU}(N)]$: mirror symmetry, spectral duality and monopoles

Francesco Aprile,^a Sara Pasquetti^a and Yegor Zenkevich^{a,b}

^a*Dipartimento di Fisica, Università di Milano-Bicocca and INFN — Sezione di Milano-Bicocca, I-20126 Milano, Italy*

^b*ITEP,*

Moscow 117218, Russia

E-mail: francesco.aprile1@unimib.it, sara.pasquetti@gmail.com,
yegor.zenkevich@gmail.com

ABSTRACT: We consider $T[\text{SU}(N)]$ and its mirror, and we argue that there are two more dual frames, which are obtained by adding flipping fields for the moment map on the Higgs and Coulomb branch. Turning on a monopole deformation in $T[\text{SU}(N)]$, and following its effect on each dual frame, we obtain four new daughter theories dual to each other. We are then able to construct pairs of $3d$ spectral dual theories by performing simple operations on the four dual frames of $T[\text{SU}(N)]$. Engineering these $3d$ spectral pairs as codimension-two defect theories coupled to a trivial $5d$ theory, via Higgsing, we show that our $3d$ spectral dual theories descend from spectral duality in $5d$, or fiber base duality in topological string. We provide further consistency checks about our web of dualities by matching partition functions on the squashed sphere, and in the case of spectral duality, matching exactly topological string computations with holomorphic blocks.

KEYWORDS: Duality in Gauge Field Theories, Supersymmetric Gauge Theory, Brane Dynamics in Gauge Theories, Field Theories in Lower Dimensions

ARXIV EPRINT: [1812.08142](https://arxiv.org/abs/1812.08142)

Contents

1	Introduction and summary	1
2	$T[\text{SU}(N + 1)]$ dualities	5
2.1	Mirror simmetry	7
2.2	Flip-flip duals	8
2.3	A commutative diagram	12
3	Deformations of the commutative diagram	12
3.1	Theory A: monopole deformed $T[\text{SU}(N + 1)]$	13
3.2	Theory B: monopole deformations on the mirror	19
3.3	Theory C: nilpotent Higgsing from monopoles	21
3.4	The $ABCD$ of monopole deformed $T[\text{SU}(N + 1)]$	28
4	Partition functions	31
4.1	Difference operators and dual partition functions	32
4.2	Sequential confinement: from $T[\text{SU}(N + 1)]$ to Theory A	34
4.3	Nilpotent mass deformation: from $T[\text{SU}(N + 1)]^\vee$ to Theory B	36
4.4	Partition functions on the A-to-D side	37
4.5	$T[\text{SU}(2)]$	38
5	Spectral dualities	43
5.1	$FT[\text{SU}(N + 1)]$ and its spectral dual	44
5.2	A new spectral dual pair	48
5.3	Spectral duality from fiber-base	49
A	More details on nilpotent Higgsing	55
B	Bookkeeping integrals	59
C	Holomorphic blocks calculations for \mathcal{T} and \mathcal{T}'	64
D	Fiber-base invariance and Higgsing	67

1 Introduction and summary

The study of $3d$ supersymmetric gauge theories and their dualities has received a great deal of attention in the last decade. Thanks to important achievements in the study of supersymmetric localisation (for a review see [1]), it has been possible to calculate exactly

quantities such as partition functions of $\mathcal{N} \geq 2$ theories on various 3-manifolds, and test a plethora of old and new IR dualities.

Much progress stemmed from the idea of obtaining $3d$ dualities from $4d$ Seiberg-like dualities, which was revamped in [2]. $3d$ dualities obtained from $4d$ have been in turn observed to generate old and new dual pairs when subject to various types of real mass deformations. Identifying a common ancestor of various apparently unrelated $3d$ dualities seems a useful organizing principle to attempt charting the vast landscape of $3d$ dualities. For recent results in this direction see [3, 4] and references therein.

In this paper we are interested in a different type of $3d$ dualities: we will consider mirror and *spectral* dualities for which we can identify a $5d$ ancestor, and not a $4d$ one.

Our starting point is the so-called $T[\text{SU}(N + 1)]$ quiver theory of [5], depicted in the figure 1.1. This is a $3d$ $\mathcal{N} = 4$ supersymmetry theory which can be realised on a set of D3 branes stretched between NS5 and D5 branes. The action of S -duality on Type IIB three- and five-branes can then be used to show that $T[\text{SU}(N + 1)]$ has a mirror dual, denoted by $T[\text{SU}(N + 1)]^\vee$, which is described by the same $T[\text{SU}(N + 1)]$ quiver with Higgs and Coulomb branch swapped. We will later decorate such a setup by turning on various mass deformations preserving $\mathcal{N} = 2^*$ supersymmetry.

Our first observation is that $T[\text{SU}(N + 1)]$ has *two more* dual descriptions, which we denote by $FFT[\text{SU}(N + 1)]$ and $FFT[\text{SU}(N + 1)]^\vee$. In more detail, $FFT[\text{SU}(N + 1)]$ is obtained from the very same quiver of $T[\text{SU}(N + 1)]$, by adding two extra sets of gauge singlets which couple linearly to the moment maps of the Coulomb and Higgs branches. Pictorially, $FFT[\text{SU}(N + 1)]$ is the $T[\text{SU}(N + 1)]$ theory with *flipped* Coulomb and Higgs branches. Similarly, $FFT[\text{SU}(N + 1)]^\vee$ is the $T[\text{SU}(N + 1)]^\vee$ theory with *flipped* Coulomb and Higgs branches. From our construction follows the diagram of dualities shown here below.

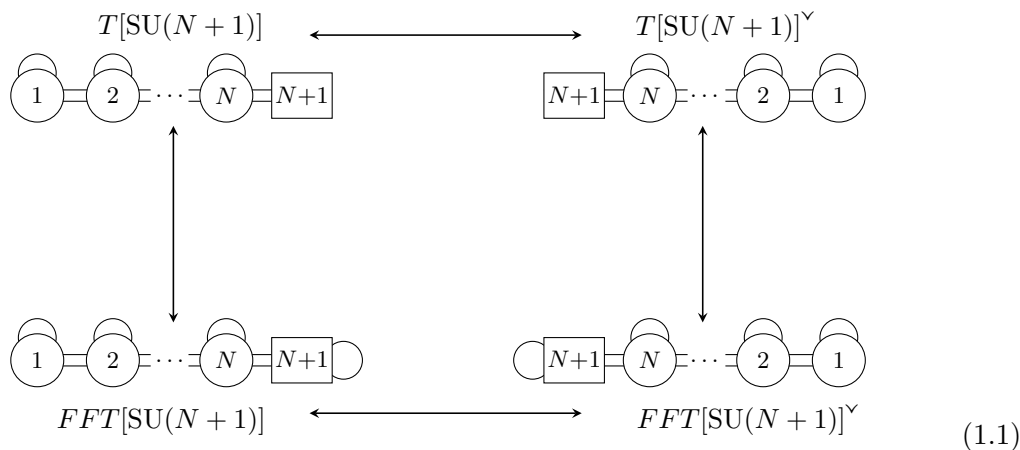

Horizontal arrows correspond to mirror dualities, while vertical arrows are new dualities which, as we will explain in more details, can be regarded as a generalization of Aharony duality [6]. We will refer to these new duality as Flip-Flip dualities. In section 2, we discuss the map between operators across the four dual frames. Particularly interesting is the way nilpotent orbits are mapped under Flip-Flip duality.

In section 4 we show equality of the partition functions on S_b^3 . Contrary to the case of $4d$ and $3d$ Seiberg-like dualities, where the equality of localised partition functions reduces to well studied integral identities in the mathematical literature, [7–9] and [10], for $T[\text{SU}(N+1)]$ and its dual partition functions there are no analogous results. So we follow the strategy of [11] regarding our partition functions as eigenfunctions of a set of Hamiltonians.

In section 3 we consider the effect of deforming $T[\text{SU}(N+1)]$ by a linear monopole superpotential as in [12, 13]. Applying the monopole duality of [15], we show that this deformation has the effect of confining sequentially all the nodes but the last one. The result is a $U(N)$ theory with $(N+1)$ flavors and several gauge singlets, which we call theory A . We then follow the monopole deformation across the duality frames and obtain four new dual theories. This is the inner $ABCD$ square shown in the picture below.

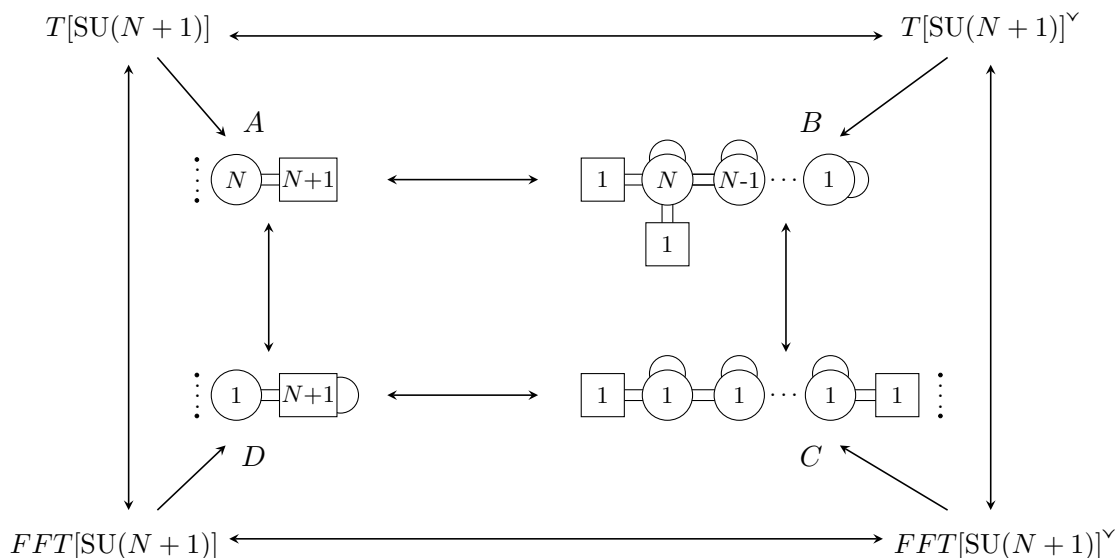

Interestingly enough, the horizontal lines in the $ABCD$ diagram also correspond to mirror dualities, while the vertical line connecting A and D is precisely Aharony duality. Mirror symmetry relates A and B in very much the same way of [13], but the connection among theories A , D and C is more involved. In particular, the original monopole deformation on $T[\text{SU}(N+1)]$ translates in $\text{FFT}[\text{SU}(N+1)]^\vee$ into a nilpotent vev for the Higgs branch flipping fields. By studying in detail the low energy theory on such nilpotent vev we show that it corresponds to the abelian quiver C in the picture. Then we obtain the same theory by performing piece-wise mirror symmetry to theory D .

In section 5 we move on to the construction of our $3d$ spectral dualities. Several ingredients goes into it. Firstly, we realise our $3d$ theories $\mathcal{T}_\mathcal{X}$ as codimension-two defect theories coupled to a (trivial) $5d$ $\mathcal{N} = 1$ bulk theory. In particular, $\mathcal{T}_\mathcal{X}$ is generated by the so-called Higgsing prescription [17], meaning that $\mathcal{T}_\mathcal{X}$ is generated by turning on appropriate vevs in $5d$ $\mathcal{N} = 1$ linear quiver theories which is geometrically engineered by (p, q) -web of NS5 and D5' branes. This higgsed configuration can be recognize as a variation of the construction given by [16], and it involves D3-branes stretching between NS5 and D5' branes, on which our defect theories live.

Secondly, we also realise our $5d$ linear quiver theory by the compactification of M-theory on a toric CY three-fold \mathfrak{X} , with the toric diagram given by the (p, q) -web. This leads to direct interpretation of the $5d$ instanton partition function as the refined topological string partition function $Z_{\text{inst, top}}^{\mathfrak{X}}$. In this language, the Higgsing prescription amounts to tuning the values of the Kähler parameters of the CY \mathfrak{X} to special quantized values in order to obtain the ‘‘Higgsed CY’’ \mathcal{X} , and typically it reduces the instanton partition function to an instanton-vortex partition function for the coupled $3d$ – $5d$ system [18–23].

In the cases we are going to consider we have a ‘‘complete Higgsing’’, by which we mean that starting from $5d$ we are left with a $3d$ theory coupled to a *trivial* $5d$ theory of free hypers. In this way we can unambiguously identify the Higgsed instanton-vortex/topological string partition function as the vortex partition function of the defect theory $Z_{\text{vort, } \mathcal{T}_{\mathcal{X}}}^{\alpha_0} = Z_{\text{vort, top}}^{\mathcal{X}}$. More precisely, we can relate the $D^2 \times S^1$ partition function of theory $\mathcal{T}_{\mathcal{X}}$ evaluated in a certain vacuum α_0 , i.e. the holomorphic block $\mathcal{B}_{\mathcal{T}_{\mathcal{X}}}^{\alpha_0}$, to the partition function of the Higgsed topological string:¹

$$\mathcal{B}_{\mathcal{T}_{\mathcal{X}}}^{\alpha_0} = Z_{\text{top}}^{\mathcal{X}}. \tag{1.2}$$

Our $5d$ linear quiver theories admits a spectral dual description which can be equivalently stated as the invariance of the topological string partition function under a fiber-base transformation: $Z_{\text{top}}^{\mathfrak{X}} = Z_{\text{top}}^{\mathfrak{X}'}$, where we denote by \mathfrak{X}' the fiber-base dual CY. Of course \mathfrak{X} and \mathfrak{X}' are just two equivalent description of the same toric CY, hence the equality of the partition functions. Therefore, our main idea is to combine Higgsing and fiber-base duality to obtain new $3d$ spectral pairs which descend from $5d$. Summarizing, we first follow the Higgsing process on \mathfrak{X} down to \mathcal{X} , which yields a $3d$ theory $\mathcal{T}_{\mathcal{X}}$. Then we follow this same Higgsing on the fiber-base dual, \mathfrak{X}' down to \mathcal{X}' , and we obtain another $3d$ theory $\mathcal{T}_{\mathcal{X}'}$ which we call the *3d spectral dual* theory. The fiber-base invariance of the Higgsed topological string partition function implies the equality of the holomorphic blocks $\mathcal{B}_{\mathcal{T}_{\mathcal{X}}}^{\alpha_0} = \mathcal{B}_{\mathcal{T}_{\mathcal{X}'}}^{\alpha_0}$ of the $3d$ spectral dual theories $\mathcal{T}_{\mathcal{X}}$ and $\mathcal{T}_{\mathcal{X}'}$.

In this paper we propose two examples of spectral dual theories and together with the topological string construction, we support our proposals by providing purely field theory arguments. A third example of spectral duality has been recently discussed in [24].

The first spectral dual pair we construct follows from the duality on the SE-NW diagonal of the $T[\text{SU}(N+1)]$ diagram, namely $FFT[\text{SU}(N+1)] \leftrightarrow T[\text{SU}(N+1)]^{\vee}$. We denote with $FT[\text{SU}(N+1)]$ the $T[\text{SU}(N+1)]$ theory with an extra set of singlets which flip only the moment map operator on the Higgs branch. Then, upon flipping the SE-NW $T[\text{SU}(N+1)]$ frames, we obtain the spectral dual pair, $FT[\text{SU}(N+1)] \leftrightarrow FT[\text{SU}(N+1)]^{\vee}$. Notice that $FT[\text{SU}(N+1)]$ has been realised previously in [25] as a defect theory in the square (p, q) -web with $(N+1)$ D5' and NS5 branes, and there it was also shown that the equality of the holomorphic blocks $\mathcal{B}_{FT[\text{SU}(N+1)]}^{\alpha_0} = \mathcal{B}_{FT[\text{SU}(N+1)]^{\vee}}^{\alpha_0}$ follows indeed from the equality of the topological string partition functions for the fiber-base dual diagrams.

The second spectral dual pair $\mathcal{T} \leftrightarrow \mathcal{T}'$ is obtained within the $ABCD$ diagram by flipping the SE-NW diagonal $D \leftrightarrow B$. We discuss the operator map and check the equality

¹For illustration, we have dropped a prefactor depending on contact terms, however keep track of it when presenting the actual matching of partition functions in section 5.3.

where we defined the matrix of bifundamentals $\mathbb{Q}^{(L,R)} = Q_{ab}^{(L,R)} \tilde{Q}_{\tilde{a}\tilde{b}}^{(L,R)}$, labelled by the pair (L, R) attached to the link between a left (L) and a right (R) node. On the first node $\mathbb{Q}^{(0,1)} = 0$. Traces Tr_k are taken in the adjoint of $U(k)$.

The global symmetry of $T[\text{SU}(N+1)]$ is $\text{SU}(N+1)_{\text{flavor}} \times \text{SU}(N+1)_{\text{top}}$. The flavor symmetry $\text{SU}(N+1)_{\text{flavor}}$ rotates the fundamental hypers at the head of the tail. The non abelian $\text{SU}(N+1)_{\text{top}}$ is an IR symmetry, and the UV Lagrangian only manifests a $U(1)_{\text{top}}^N$ topological symmetry, coming from the dual photons on the gauge nodes. For each Cartan in the flavor symmetry group and each $U(1)_{\text{top}}$ we can turn on a real masses, M_p and T_p , respectively.

The R-symmetry of a $3d \mathcal{N} = 4$ theory is $\text{SU}(2)_C \times \text{SU}(2)_H$ with Cartans $U(1)_C \subset \text{SU}(2)_C$ and $U(1)_H \subset \text{SU}(2)_H$. We will work with a family of $\mathcal{N} = 2^*$ theories obtained by introducing a real mass parameter for the anti-diagonal combination $U(1)_A = C - H$ [26]. We take the UV R-charge equal to the combination $R_0 = C + H$. In the IR, the R-symmetry can mix with other abelian symmetries, but since the topological symmetry is non-abelian, R_0 will only mix with $U(1)_A$. Thus we introduce a trial R-charge, defined by $R = C + H + \alpha(C - H)$ for some $\alpha \in \mathbb{R}$. For the bifundamental fields we find $R = \frac{1-\alpha}{2} \equiv r$, in agreement with the assignment $C = 0, H = \frac{1}{2}$. For the adjoint fields $R[\Phi_k] = 2(1-r)$ iff the superpotential has R-charge 2. Notice also that $R[\Phi_k] = 1 + \alpha = 2(1-r)$ is consistent with $C = 1$ and $H = 0$. The exact value of r can be fixed by F-extremization [27].

We define the gauge invariant $(N+1) \times (N+1)$ meson matrix:

$$\mathcal{Q}_{ij} \equiv \text{Tr}_N \mathbb{Q}^{(N,N+1)}, \quad R[\mathcal{Q}_{ij}] = 2r. \tag{2.3}$$

The dynamics might impose additional relations on \mathcal{Q}_{ij} , thus restricting the set of generators of the Higgs branch (HB) chiral ring. Classical relations follow from the F-terms, and for $T[\text{SU}(N+1)]$ the F-terms of the fields Φ_k imply that \mathcal{Q} is nilpotent [5]. The argument goes as follows: $\mathcal{Q} = \tilde{Q}^{(N,N+1)} Q^{(N,N+1)}$ has rank at most N by definition. Then, the F-term of Φ_N can be used to rewrite

$$\mathcal{Q}^2 = \tilde{Q}^{(N,N+1)} Q^{(N,N+1)} \tilde{Q}^{(N,N+1)} Q^{(N,N+1)} \tag{2.4}$$

$$= (\tilde{Q}^{(N,N+1)} \tilde{Q}^{(N-1,N)}) (Q^{(N-1,N)} Q^{(N,N+1)}) \tag{2.5}$$

which implies \mathcal{Q}^2 has at most rank $N-1$. Iterating this computation we find that certainly $\mathcal{Q}^{N+1} = 0$. The Higgs branch is related to the nilpotent cone \mathcal{N} for matrices in $\text{SL}(N+1, \mathbb{C})$. This space can be organized as the union of all the orbits $S \cdot \mathbb{J}_{\underline{\lambda}} \cdot S^{-1}$ where $S \in \text{SL}(N+1, \mathbb{C})$ and \mathbb{J} is the Jordan form associated to a partition $\underline{\lambda}$ of $N+1$, see [28] for a review on related topics.

The meson \mathcal{Q} comes along with the moment map operator $\Pi^{\mathcal{Q}}$, which is better suited to describe global symmetries of the theory. Indeed, $\Pi^{\mathcal{Q}}$ is the half-BPS primary in a supermultiplet which contains conserved global currents. In our case, $\Pi^{\mathcal{Q}}$ is defined as

$$\Pi^{\mathcal{Q}} \equiv \mathcal{Q} - \frac{1}{N+1} \text{Tr} \mathcal{Q}. \tag{2.6}$$

Coulomb branch (CB) operators can be obtained from $\text{Tr} \Phi_k$ and monopole operators $\mathcal{M}^{f_1 \dots f_N}$ carrying f_i units of flux for the topological $U(1)$ on the i -th node. The R-charge

of a (BPS) monopole operator is determined by the R-charges of all the fermions ψ of the theory by the formula:

$$R[\mathcal{M}^{f_1, \dots, f_N}] = -\frac{1}{2} \sum_{\text{fermions } \psi} R[\psi] |\rho_\psi(f_1, \dots, f_N)|, \tag{2.7}$$

where $\rho_\psi(f_1, \dots, f_N)$ is the monopole charge of ψ [5, 29, 30].³ We find that monopole operators defined by a string of fluxes of the form $[0^n(\pm 1)^m 0^p]$, where 0 and 1 are repeated with integer multiplicities n, m , and p constrained by $n + m + p = N$, have the same R-charge of the adjoint fields, i.e. $R[\Phi_k] = 2(1 - r)$. These monopole operators are $N(N + 1)$ and together with the $\Phi_{k=1, \dots, N}$ can be arranged into a $(N + 1) \times (N + 1)$ matrix, analogous to the meson matrix. For $N = 3$ this matrix reads

$$\mathcal{M}_{ij} \equiv \begin{pmatrix} 0 & \mathcal{M}^{[1,0,0]} & \mathcal{M}^{[1,1,0]} & \mathcal{M}^{[1,1,1]} \\ \mathcal{M}^{[-1,0,0]} & 0 & \mathcal{M}^{[0,1,0]} & \mathcal{M}^{[0,1,1]} \\ \mathcal{M}^{[-1,-1,0]} & \mathcal{M}^{[0,-1,0]} & 0 & \mathcal{M}^{[0,0,1]} \\ \mathcal{M}^{[-1,-1,-1]} & \mathcal{M}^{[0,-1,-1]} & \mathcal{M}^{[0,0,-1]} & 0 \end{pmatrix} + \sum_{i=1}^3 \text{Tr} \Phi_i \mathcal{D}_i \tag{2.8}$$

where \mathcal{D}_i are traceless diagonal generators of $\text{SU}(N + 1)_{\text{top}}$. The generators of the CB chiral ring can be obtained from such an \mathcal{M}_{ij} upon imposing further relations.

In the rest of the paper we will refer to a matrix assembled as in (2.8), as the monopole matrix of the theory under consideration.

The moment map $\Pi^\mathcal{Q}$ and the monopole matrix belong to the adjoint of $\text{SU}(N + 1)$.

2.1 Mirror symmetry

It is well known that $T[\text{SU}(N + 1)]$ is self-dual under mirror symmetry [5]. The dual theory, hereafter $T[\text{SU}(N + 1)]^\vee$, has quiver diagram

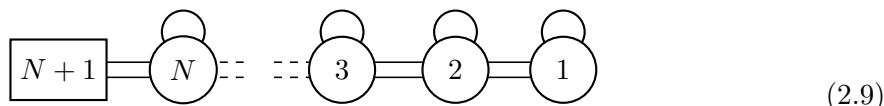

and the same field content as $T[\text{SU}(N + 1)]$. In $T[\text{SU}(N + 1)]^\vee$ we denote the adjoint chirals by Ω_k , the monopoles operators by $\mathcal{N}_{f_1 \dots f_N}$, and the bifundamental fields by P_{ab} and $\tilde{P}_{\tilde{a}\tilde{b}}$. The indexes k and $f_1 \dots f_N$ have the same meaning as in $T[\text{SU}(N + 1)]$. We introduce the matrix $\mathbb{P}^{(L,R)} = P_{ab}^{(L,R)} \tilde{P}_{\tilde{a}\tilde{b}}^{(L,R)}$ for each pair of nodes (L, R) . Then the dual the superpotential reads

$$W^{T^\vee} = W^T[\Omega, \mathbb{P}]. \tag{2.10}$$

Mirror symmetry exchanges the Higgs and Coulomb branch. Therefore the bifundamental fields have now R-charge $R[P_{ab}] = 1 - r$. Consequently the monopole operators have R-charge $R[\mathcal{N}_{ij}] = 2r$. It follows from the superpotential that $R[\Omega_k] = 2r$ for any k .

³Example: consider a $\text{U}(N)$ theory with $2N$ flavors Q, \tilde{Q} , an adjoint $\Phi \in \text{U}(N)$, and superpotential $\mathcal{W} = \Phi Q \tilde{Q}$. The monopoles $\mathcal{M}^{\pm 1}$ have $R[\mathcal{M}^{\pm 1}] = 2N(1 - R_Q) + (N - 1)(1 - R_\Phi) - (N - 1)$, which in our case becomes $R[\mathcal{M}^{\pm 1}] = 2 - 2r$.

	0	1	2	3	4	5	6	7	8	9
NS5	–	–	–					–	–	–
D5	–	–	–		–	–	–			
D3	–	–	–	–						

Table 1. The brane setup giving rise to the 3d $\mathcal{N} = 4$ $T[\text{SU}(N + 1)]$ gauge theory.

On the Higgs branch we define the meson \mathcal{P} and its moment map $\Pi^{\mathcal{P}}$. The meson is

$$\mathcal{P}_{ij} \equiv \text{Tr}_N \mathbb{P}^{(N+1, N)}, \quad R[\mathcal{P}_{ij}] = 2 - 2r. \quad (2.11)$$

On the Coulomb branch we consider the monopole matrix \mathcal{N}_{ij} , which similarly to the previous section, is obtained from $\text{Tr} \Omega_k$ and from monopole operators with fluxes valued in $[0^n 1^m 0^p]$. For $N = 3$ we have

$$\mathcal{N}_{ij} \equiv \begin{pmatrix} 0 & \mathcal{N}^{[1,0,0]} & \mathcal{N}^{[1,1,0]} & \mathcal{N}^{[1,1,1]} \\ \mathcal{N}^{[-1,0,0]} & 0 & \mathcal{N}^{[0,1,0]} & \mathcal{N}^{[0,1,1]} \\ \mathcal{N}^{[-1,-1,0]} & \mathcal{N}^{[0,-1,0]} & 0 & \mathcal{N}^{[0,0,1]} \\ \mathcal{N}^{[-1,-1,-1]} & \mathcal{N}^{[0,-1,-1]} & \mathcal{N}^{[0,0,-1]} & 0 \end{pmatrix} + \sum_{i=1}^3 \text{Tr} \Omega_i \mathcal{D}_i \quad (2.12)$$

where again \mathcal{D}_i are traceless diagonal generators of $\text{SU}(N + 1)$.

Mirror symmetry exchanges

$$\mathcal{M}_{ij} \leftrightarrow \Pi_{ij}^{\mathcal{P}} \quad ; \quad \Pi_{ij}^{\mathcal{Q}} \leftrightarrow \mathcal{N}_{ij}. \quad (2.13)$$

and therefore HB and CB.

The fact that $T[\text{SU}(N + 1)]$ is self-dual under mirror symmetry can be neatly derived from the IIB brane engineering of the $T[\text{SU}(N + 1)]$. More precisely, $T[\text{SU}(N + 1)]$ can be understood as the low energy theory of a system of D3 branes suspended between $(N + 1)$ D5 and NS5 branes [32]. The brane configuration is summarized in table 1 and goes as follows. The NS5 extend along directions 012789, and the D5 branes along directions 012456. The NS5 and D5 branes are separated in the third direction, where $(N + 1)$ D3 branes are stretched in between, so that each NS5 brane is connected to a distinct D5 brane. These D3 branes extend along directions 0123, but since they are bounded in the third direction by D5 and NS5 branes, the low energy dynamics on their worldvolume is three-dimensional. In fact it is precisely the $T[\text{SU}(N + 1)]$ theory. The R -symmetry group factors $\text{SU}(2)_C$ and $\text{SU}(2)_H$ correspond to the rotation symmetry of the NS5 and D5 branes in the directions transverse to the D3 branes, i.e. to $\text{SO}(3)_{456}$ and $\text{SO}(3)_{789}$ respectively. The action of mirror symmetry, which exchanges CB and HB, is precisely that of IIB S -duality, which exchanges the NS5 and D5 branes (leaving the system invariant). Equivalently, one can think of this transformation as the exchange of the 456 and 789 directions.

2.2 Flip-flip duals

In this section we propose new duals for $T[\text{SU}(N + 1)]$ and its mirror. We name them Flip-Flip dualities for reasons that will become soon clear.

Let us begin by describing the Flip-Flip dual of $T[\text{SU}(N+1)]$, which we denote by $FFT[\text{SU}(N+1)]$. This theory has the content of $T[\text{SU}(N+1)]$ plus two extra sets of fields, the *flipping fields*. We represent $FFT[\text{SU}(N+1)]$ by the quiver

$$(2.14)$$

where the horizontal loops attached on the flavor node indicate the addition of flipping fields. We have adjoint chiral fields Θ_k , bifundamental fields R_{ab} and $\tilde{R}_{\tilde{a}\tilde{b}}$, with $R[R_{ab}] = R[\tilde{R}_{\tilde{a}\tilde{b}}] = 1 - r$, and monopoles operators. Out of them, we define the meson \mathcal{R}_{ij} , its moment map $\Pi_{ij}^{\mathcal{R}}$, and the monopole matrix m_{ij} . The flipping fields are elementary fields, singlet of gauge groups, and transform respectively in the adjoint of $\text{SU}(N+1)_{\text{flavor}}$ and $\text{SU}(N+1)_{\text{top}}$, in particular they are traceless. These are denoted by $F_{ij}^{\mathcal{R}}$ and F_{ij}^m , since they will couple to \mathcal{R}_{ij} and m_{ij} in the superpotential:

$$W^{FFT} = W^T[\Theta, \mathbb{R}] - F_{ij}^{\mathcal{R}} \Pi_{ij}^{\mathcal{R}} - m_{ij} F_{ij}^m. \quad (2.15)$$

From W^{FFT} we deduce the R-charge assignment, $R[F_{ij}^m] = 2 - 2r$ and $R[F_{ij}^{\mathcal{R}}] = 2r$. We then discover that the Flip-Flip duality between $T[\text{SU}(N+1)]$ and $FFT[\text{SU}(N+1)]$ maps:

$$\Pi^{\mathcal{Q}} \leftrightarrow F^{\mathcal{R}} \quad ; \quad \mathcal{M} \leftrightarrow F^m. \quad (2.16)$$

The F-terms of $F_{ij}^{\mathcal{R}}$ and F_{ij}^m imply $\Pi_{ij}^{\mathcal{R}} = 0$ and $m_{ij} = 0$. As a result, the HB and CB will now be described by $F_{ij}^{\mathcal{R}}$ and F_{ij}^m , respectively. In this sense, $F_{ij}^{\mathcal{R}}$ is the flip of the moment map, i.e. the meson \mathcal{R}_{ij} , and F_{ij}^m that of the monopole matrix.

It is interesting to look at the description of the HB. The F-terms of the bifundamentals $R^{(k,k+1)}$ and $\tilde{R}^{(k,k+1)}$ imply the equations

$$\tilde{R}^{(k,k+1)} \Theta_k = \Theta_{k+1} \tilde{R}^{(k,k+1)} \quad (2.17)$$

$$\Theta_k R^{(k,k+1)} = R^{(k,k+1)} \Theta_{k+1} \quad (2.18)$$

where we defined $\Theta_{N+1} \equiv F^{\mathcal{R}}$ so to have a uniform notation in (2.17) and (2.18). The F-terms of the diagonal component of the monopole matrix give $\text{Tr} \Theta_k = 0$ for all $k \leq N$, in particular $\Theta_1 = 0$. Furthermore, it is always possible to use $\text{SU}(N)_{\text{gauge}} \times \text{SU}(N+1)_{\text{flavor}}$ to put one of the bifundamentals on the last link in a diagonal form. For concreteness we take,

$$\langle \tilde{R}^{(N,N+1)} \rangle = \begin{bmatrix} v_1 & 0 & \dots & 0 \\ 0 & v_2 & \dots & 0 \\ 0 & 0 & \dots & 0 \\ 0 & 0 & \dots & v_N \\ 0 & 0 & \dots & 0 \end{bmatrix}. \quad (2.19)$$

with arbitrary v_i . The constraint $\Pi_{ij}^{\mathcal{R}} = 0$ trivializes (2.18). Let us discuss the case $N = 1$ to start with. From (2.17) we find

$$0 = \tilde{R}^{(1,2)} \Theta_1 = \Theta_2 \begin{bmatrix} v_1 \\ 0 \end{bmatrix}, \quad (2.20)$$

therefore $\tilde{R}^{(1,2)}$ is in the kernel of Θ_2 . The flipping fields Θ_2 are in the adjoint of $SU(2)$ and we shall take $\text{Tr}\Theta_2 = 0$. It follows that a traceless matrix in the adjoint with a one dimensional kernel can be put into the form,

$$\Theta_2 = \begin{bmatrix} 0 & \theta_2 \\ 0 & 0 \end{bmatrix}. \tag{2.21}$$

i.e. Θ_2 is nilpotent. More in general, we can use a recursive argument to show that Θ_{N+1} can be taken to be nilpotent. So let us assume that Θ_N is nilpotent, and consider the matrix $R_{\text{aux}}^{(N,N+1)}$ such that $R_{\text{aux}}^{(N,N+1)} \langle \tilde{R}^{(N,N+1)} \rangle = \mathbb{I}_{N \times N}$. This matrix can be explicitly constructed in the gauge (2.19). Then (2.17) becomes

$$\Theta_N = R_{\text{aux}}^{(N,N+1)} \Theta_{N+1} \langle \tilde{R}^{(N,N+1)} \rangle. \tag{2.22}$$

Considering Θ_N is in its Jordan Form we introduce a basis $\{\vec{w}_i\}$ such that:

$$\begin{aligned} \Theta_N \vec{w}_1 &= 0 \\ \Theta_N \vec{w}_i &= \sum_{j < i} c_i^j \vec{w}_j \quad i \geq 2 \end{aligned} \tag{2.23}$$

for given coefficients c_i^j which depend on the partition associated to Θ_N as nilpotent matrix. Equations (2.22) now imply the relations

$$\begin{aligned} R_{\text{aux}}^{(N,N+1)} \Theta_{N+1} \langle \tilde{R}^{(N,N+1)} w_1 \rangle &= 0 \\ R_{\text{aux}}^{(N,N+1)} \Theta_{N+1} \langle \tilde{R}^{(N,N+1)} w_i \rangle &= \sum_{j < i} c_i^j w_j. \end{aligned} \tag{2.24}$$

Since $\vec{w}_{i=1, \dots, N}$ is a basis, the span of $\vec{u}_i = \langle \tilde{R}^{(N,N+1)} \vec{w}_i \rangle$ is by construction an N -dimensional subspace in $N + 1$ dimensions. The solution of (2.24) is then

$$\begin{aligned} \Theta_{N+1} \langle \tilde{R}^{(N,N+1)} w_1 \rangle &= \theta_2 K \\ \Theta_{N+1} \langle \tilde{R}^{(N,N+1)} w_i \rangle &= \sum_{j < i} c_i^j \langle \tilde{R}^{(N,N+1)} w_j \rangle + \theta_{i+1} K \quad i \geq 2 \end{aligned} \tag{2.25}$$

where K parametrizes the one dimensional kernel of $R_{\text{aux}}^{(N,N+1)}$, and the coefficients θ_i are arbitrary. It is straightforward to plug (2.25) back into (2.24) and check that the equations are satisfied by using $R_{\text{aux}}^{(N,N+1)} \langle \tilde{R}^{(N,N+1)} \rangle = \mathbb{I}_{N \times N}$. Moreover, this relation implies that K and the set of vectors $\{\vec{u}_i\}$ are independent, and therefore we can use them to span a basis in $N + 1$ dimensions. Thus we fix completely Θ_{N+1} by specifying its action on such an basis, i.e. by adding $\Theta_{N+1} K$ to the list in (2.25). The nilpotent solution is given by

$$\begin{aligned} \Theta_{N+1} K &= 0 \\ \Theta_{N+1} \langle \tilde{R}^{(N,N+1)} w_1 \rangle &= \theta_2 K \\ \Theta_{N+1} \langle \tilde{R}^{(N,N+1)} w_i \rangle &= \sum_{j < i} c_i^j \langle \tilde{R}^{(N,N+1)} w_j \rangle + \theta_{i+1} K \quad i \geq 2 \end{aligned} \tag{2.26}$$

where the θ_j play a role analogous to θ_2 appearing in (2.21).

The outcome of our computation is interesting for two reasons: on one hand we obtained nilpotent solutions for the vev of the flipping fields, which in turn supports our duality, i.e. our identification $\Pi^{\mathcal{Q}} \leftrightarrow F^{\mathcal{R}}$. On the other hand, this nilpotency condition on the flipping fields shows up in a totally opposite way compared to the case of the meson \mathcal{Q} in $T[\text{SU}(N+1)]$. As reviewed in the Introduction, in order to show that \mathcal{Q} is nilpotent in $T[\text{SU}(N+1)]$ we used the F -term constraints starting from the head of the tail back to the first gauge node. For the flipping fields, instead, we used F -term constraints recursively from the first gauge node up to the head of $FFT[\text{SU}(N+1)]$. We will have more to say about this in section 3.3.

In the case of $N = 1$, our duality relates $T[\text{SU}(2)]$ to a $U(1)$ theory with two flavors and various singlets. This case can be understood as a version of the Aharony duality, as we now argue. Let us recall that Aharony duality maps $\mathcal{N} = 2$ SQED theory with two electric flavors (Q_i, \tilde{Q}_j) and no superpotential, to an abelian theory with two magnetic flavors (q_i, \tilde{q}_j) , and extra singlets M_{ij} and S^\pm . The magnetic superpotential is non trivial: $W_{\text{magn.}} = \sum_{ij} M_{ij} q_i \tilde{q}_j + V^- S^+ + V^+ S^-$. In our language, M_{ij} and S^\pm are “flipping” fields for the magnetic mesons $q_i \tilde{q}_j$, and for the dual monopoles V^\pm , respectively. Notice that M_{ij} belongs to the adjoint of $U(2)$, so it is not yet our flipping field. In order to get $T[\text{SU}(2)]$ out of the electric side of Aharony duality, we introduce an extra singlet ϕ , and we add a cubic superpotential of the form $W_{el.} = \phi \sum_i Q_i \tilde{Q}_i$. This is indeed the tail superpotential for $T[\text{SU}(2)]$. Adding a corresponding singlet field ϕ' also on the magnetic side, Aharony duality maps our deformation to the mass term $\phi' \text{Tr}(M)$. Integrating out these two fields in the full magnetic superpotential, we obtain:

$$W'_{\text{magn.}} = \left(M - \frac{\text{Tr}(M)}{2} \mathbb{I} \right)_{ij} q_i \tilde{q}_j + V^- S^+ + V^+ S^-.$$

At this point the meson $q_i \tilde{q}_j$ can be replaced by its moment map without changing $W'_{\text{magn.}}$. Then, $W'_{\text{magn.}}$ will be precisely what turns out to be the superpotential of $FFT[\text{SU}(2)]$. The expression of W^{FFT} in this case is,

$$\begin{aligned} W^{FFT} &= W^T[\Theta, \mathbb{R}] - \mathcal{R}_{ij} F_{ij}^{\mathcal{R}} - m_{ij} F_{ij}^m \\ &= \theta \sum_i r_i \tilde{r}_i - F_{ij}^{\mathcal{R}} \Pi_{ij}^{\mathcal{R}} - m^+ F_+^m - m^- F_-^m - \theta F_3^m, \end{aligned} \tag{2.27}$$

where θF_3^m is the coupling due to the σ_3 generator in (2.8). Similarly for $m^\pm F_\pm^m$. Integrating out F_3^m , we recover $W'_{\text{magn.}}$ upon a trivial field redefinition.

The Flip-Flip duality on the mirror side works in a similar fashion: the starting point is $T[\text{SU}(N+1)]^\vee$ and its quiver diagram (2.9). The quiver diagram of $FFT[\text{SU}(N+1)]^\vee$ is essentially (2.9), except for the flavor node on which the new flipping fields are attached. On $FFT[\text{SU}(N+1)]^\vee$ we will use the following notation: Ψ_k for the adjoint chirals, S_{ab} and $\tilde{S}_{\tilde{a}\tilde{b}}$ for the bifundamental fields, with $R[S_{ab}] = R[\tilde{S}_{\tilde{a}\tilde{b}}] = r$, \mathcal{S}_{ij} for the mesons and n_{ij} for the monopole matrix. The flipping fields are denoted by $F_{ij}^{\mathcal{S}}$ and F_{ij}^n . The superpotential is

$$W^{FFT^\vee} = W^T[\Psi, \mathbb{S}] - F_{ij}^{\mathcal{S}} \Pi_{ij}^{\mathcal{S}} - n_{ij} F_{ij}^n, \tag{2.28}$$

from which we read the R-charges $R[F_{ij}^n] = 2r$ and $R[F_{ij}^S] = 2 - 2r$. According to the Flip-Flip duality between $T[\text{SU}(N+1)]^\vee$ and $FFT[\text{SU}(N+1)]^\vee$ the operators are mapped as

$$\Pi^{\mathcal{P}} \leftrightarrow F^{\mathcal{S}} \quad ; \quad \mathcal{N} \leftrightarrow F^n. \quad (2.29)$$

2.3 A commutative diagram

We can represent our four dualities through the following commutative diagram:

$$\begin{array}{ccc}
 T[\text{SU}(N+1)] & \longleftrightarrow & T[\text{SU}(N+1)]^\vee \\
 \uparrow \begin{array}{l} \Pi^{\mathcal{Q}} \\ \mathcal{M} \end{array} & & \uparrow \begin{array}{l} \Pi^{\mathcal{P}} \\ \mathcal{N} \end{array} \\
 \begin{array}{c} \text{1} \text{---} \text{2} \text{---} \dots \text{---} \text{N} \text{---} \text{N+1} \\ \text{1} \text{---} \text{2} \text{---} \dots \text{---} \text{N} \text{---} \text{N+1} \end{array} & & \begin{array}{c} \text{N+1} \text{---} \text{N} \text{---} \dots \text{---} \text{2} \text{---} \text{1} \\ \text{N+1} \text{---} \text{N} \text{---} \dots \text{---} \text{2} \text{---} \text{1} \end{array} \\
 \downarrow \begin{array}{l} F^{\mathcal{R}} \\ F^m \end{array} & & \downarrow \begin{array}{l} F^{\mathcal{S}} \\ F^n \end{array} \\
 FFT[\text{SU}(N+1)] & \longleftrightarrow & FFT[\text{SU}(N+1)]^\vee
 \end{array} \quad (2.30)$$

Horizontal arrows connect mirror dual theories while vertical arrows connect flip-flip dual theories.

We stress an important property of the commutative diagram: if we turn off real axial mass deformations, both $T[\text{SU}(N+1)]$ and $T[\text{SU}(N+1)]^\vee$ are strictly $\mathcal{N} = 4$ theories, and our duality web implies that both $FFT[\text{SU}(N+1)]$ and $FFT[\text{SU}(N+1)]^\vee$ have to acquire an emergent $\mathcal{N} = 4$ symmetry in the IR (even though their UV superpotentials preserve only $\mathcal{N} = 2$). In section 4.1 we provide further evidence about the diagram (2.30), hence of the emergent $\mathcal{N} = 4$, by showing that the partition functions of the four dual theories are all equal as function of the fugacities for the global symmetries. A first indication of this fact comes from F-extremization [27]. Indeed, when we extremize the partition functions we set to zero the fugacities for the non-abelian symmetries, since these can't mix with the R-charge. But, as we will see later, if we turn-off the non-abelian fugacities, the contribution of the two sets of flipping fields cancel-out, hence the extremal R-charges for $FFT[\text{SU}(N+1)]$ and $T[\text{SU}(N+1)]$ are the both equal to $1/2$, which is the $\mathcal{N} = 4$ value.

In section 5.1 we will argue that the $FFT[\text{SU}(N+1)]^\vee$ theory can be realised on a brane set-up consisting of D3 branes suspended between NS5' and D5' branes preserving $\mathcal{N} = 4$ supersymmetry.

3 Deformations of the commutative diagram

In this section we consider a certain monopole deformation of $T[\text{SU}(N+1)]$ and follow its RG-flow across the commutative diagram. This computation offers an interesting and novel consistency check about the (mother) $T[\text{SU}(N+1)]$ commutative diagram, and produces

where the magnetic fields M_{ij} replace the electric meson. This is the first instance of a family of electric-magnetic dualities introduced in [15]:

$$U(N_c) \oplus N_{flav.} \text{ and } W = \mathcal{M}^+ \leftrightarrow N_f^2 \oplus 1 \text{ singlets } M_{ij} \oplus \gamma \text{ and } W = \gamma \det M \quad (3.7)$$

The map (3.7) does not include adjoint fields, which instead are present on the quiver tail. However, on the first node, Φ_1 is just a singlet, thus it can be taken into account afterwards. Similarly, we add the coupling $\gamma \det M$ on top of W^T .

Since the magnetic dual of a $U(1)$ gauge theory with two flavors is a Wess-Zumino model, the $U(1)$ dynamics has confined in the IR. The presence of W^T allows for a sequence of iterations of this procedure, where at each step the duality (3.7) is used for an increasing value of N_c . This is the content of the sequential confinement introduced by [12]. Here we generalize it to the case of $T[SU(N + 1)]$, building on previous work done in [13]. Before presenting results for the final low energy theory, we discuss in detail the confinement of the first two nodes.

Move # 1. Consider the restriction of $T[SU(N + 1)]$ to the first and the second gauge node. Locally, the theory is described by the quiver



with superpotential

$$W_{\text{def}}^{T[SU(3)]} = \mathcal{W}_1 + \mathcal{W}_2 + \sum_{a=1}^3 \phi_2^a \text{Tr}_2 \left[T^a \left(\text{Tr}_3 \mathbb{Q}^{(2,3)} - \text{Tr}_1 \mathbb{Q}^{(1,2)} \right) \right] + \mathcal{M}^{[10 \dots 00]}$$

$$\mathcal{W}_1 + \mathcal{W}_2 = \text{Tr} \Phi_1 \left[\text{Tr}_1 \text{Tr}_2 \mathbb{Q}^{(1,2)} \right] + \frac{1}{2} \text{Tr} \Phi_2 \left[\text{Tr}_2 \text{Tr}_3 \mathbb{Q}^{(2,3)} - \text{Tr}_2 \text{Tr}_1 \mathbb{Q}^{(1,2)} \right] \quad (3.9)$$

where in (3.9) we have specified the abelian component. Notice the property $\text{Tr}_1 \text{Tr}_2 \mathbb{Q}^{(1,2)} = \text{Tr}_2 \text{Tr}_1 \mathbb{Q}^{(1,2)}$, i.e. we can commute the two traces.

We use the monopole duality (3.6) on the first gauge node. Accordingly, we replace the electric meson, $\text{Tr}_1 \mathbb{Q}^{(1,2)} \rightarrow M_2$, where M_2 is in the adjoint of $U(2)$, the second gauge node. In the dual theory the superpotential has become:

$$W_{\text{def}}^{T[SU(3)]} = \mathcal{W}_1 + \mathcal{W}_2 + \sum_{a=1}^3 \phi_2^a \text{Tr}_2 \left[T^a \left(\text{Tr}_3 \mathbb{Q}^{(2,3)} - M^{(2)} \right) \right] + \gamma_2 \det M_2 + \mathcal{M}^{[01 \dots 00]}$$

$$(3.10)$$

where the abelian superpotential reads,

$$\mathcal{W}_1 + \mathcal{W}_2 = \text{Tr} \Phi_1 \text{Tr} M_2 + \frac{1}{2} \text{Tr} \Phi_2 \left[\text{Tr}_2 \text{Tr}_3 \mathbb{Q}^{(2,3)} - \text{Tr} M_2 \right] \quad (3.11)$$

The interaction term, $\gamma_2 \det M_2$, is part of the duality map. It is convenient to rotate the abelian adjoints to

$$\varphi_2^- \equiv \left(\text{Tr} \Phi_1 - \frac{1}{2} \text{Tr} \Phi_2 \right) \quad \varphi_2^+ \equiv \left(\text{Tr} \Phi_1 + \frac{1}{2} \text{Tr} \Phi_2 \right) \quad (3.12)$$

in such a way that

$$\mathcal{W}_1 + \mathcal{W}_2 = \varphi_2^- \left(\text{Tr} M_2 - \frac{1}{2} \text{Tr}_2 \text{Tr}_3 \mathbb{Q}^{(2,3)} \right) + \frac{1}{2} \varphi_2^+ \text{Tr}_2 \text{Tr}_3 \mathbb{Q}^{(2,3)} \quad (3.13)$$

An important remark is that M_2 is an elementary field in the dual theory. Then the F-term of φ_2^- and $\phi_{a=1,2,3}$, determine a vev for M_2 . In particular, $\langle M_2 \rangle$ depends on $\text{Tr}_3 \mathbb{Q}^{(2,3)}$ as follows

$$\text{Tr} \langle M_2 \rangle - \frac{1}{2} \text{Tr}_2 \text{Tr}_3 \mathbb{Q}^{(2,3)} = 0, \quad \text{Tr}_2 \left[T^{a=1,2,3} \left(\langle M_2 \rangle - \text{Tr}_3 \mathbb{Q}^{(2,3)} \right) \right] = 0 \quad (3.14)$$

Equations (3.14) imply that $\langle M_2 \rangle$ has the same non abelian components of $\text{Tr}_3 \mathbb{Q}^{(2,3)}$ but differ by a factor of $\frac{1}{2}$ in the abelian component. In matrix form, the solution is

$$\langle M_2 \rangle = \text{Tr}_3 \mathbb{Q}^{(2,3)} - \frac{\text{Tr}_2 \text{Tr}_3 \mathbb{Q}^{(2,3)}}{2 * 2} \mathbb{I}_{2 \times 2} \quad (3.15)$$

Expanding the superpotential around $M_2 = \langle M_2 \rangle + \delta M_2$, we find mass terms for φ_2^- , δM_2 , and for the non abelian adjoint fields ϕ^a . This is obvious from (3.10) and (3.13). Below a common mass scale, all these fields can be integrated out. As a result, the second node has now only a light U(1) adjoint scalar φ_2^+ , and the bifundamentals on the (2, 3) link. On the vacuum $\langle M_2 \rangle$ there is a novel effective superpotential, which we determine in the next paragraph.

To proceed further, we would like to express $\det \langle M_2 \rangle$ in terms of traces over matrices in the adjoint of U(3). The reason is that a matrix in the adjoint of U(3) plays the role of the meson matrix for $T[\text{SU}(3)]$. Thinking about iterating the duality (3.7) on node (2), this rewriting is clearly necessary. To achieve the desired result, we first expand

$$\det M_2 = \frac{1}{2} [\text{Tr} M_2]^2 - \frac{1}{2} \text{Tr} [M_2 M_2] \quad (3.16)$$

Then, we rewrite

$$\begin{aligned} \text{Tr} [M_2 M_2] &= \text{Tr}_2 \left[\text{Tr}_3 \mathbb{Q}^{(2,3)} \cdot \text{Tr}_3 \mathbb{Q}^{(2,3)} \right] - \frac{\text{Tr}_2 \text{Tr}_3 \mathbb{Q}^{(2,3)}}{2} \text{Tr}_2 \left[\text{Tr}_3 \mathbb{Q}^{(2,3)} \right] \\ &\quad + \frac{(\text{Tr}_2 \text{Tr}_3 \mathbb{Q}^{(2,3)})^2}{8} \end{aligned} \quad (3.17)$$

Finally, two additional manipulations: in the abelian case we interchange the traces in the obvious way, $\text{Tr}_2 \text{Tr}_3 \mathbb{Q}^{(2,3)} = \text{Tr}_3 \text{Tr}_2 \mathbb{Q}^{(2,3)}$. In the non-abelian case, we notice the property

$$\begin{aligned} \text{Tr}_2 \left[\text{Tr}_3 \mathbb{Q}^{(2,3)} \cdot \text{Tr}_3 \mathbb{Q}^{(2,3)} \right] &= \sum_{x,y=1}^2 \sum_{n=1}^3 Q_{xn} \tilde{Q}_{ny} \sum_{m=1}^3 Q_{ym} \tilde{Q}_{mx} \\ &= \sum_{m,n=1}^3 \sum_{x=1}^2 Q_{xn} \tilde{Q}_{mx} \sum_{y=1}^2 Q_{ym} \tilde{Q}_{ny} \\ &= \text{Tr}_3 \left[\text{Tr}_2 \mathbb{Q}^{(2,3)} \cdot \text{Tr}_2 \mathbb{Q}^{(2,3)} \right] \end{aligned}$$

The resulting theory has the following quiver diagram,

$$\gamma_2, \quad \begin{array}{c} \text{blue loop} \\ \circlearrowleft \\ \text{---} \text{---} \\ \text{---} \text{---} \\ \square \end{array} \quad (3.18)$$

where the blue loop stands now for φ_2^+ , instead of the full adjoint, and we remind ourselves of γ_2 by displaying it on the l.h.s. of the diagram. The effective superpotential associated to (3.18) is,

$$W_{\text{eff}}^{T[\text{SU}(3)]} = \frac{1}{2}\varphi_2^+ \text{Tr}_3 \text{Tr}_2 \mathbb{Q}^{(2,3)} + \frac{1}{2}\gamma_2 \left[-\text{Tr}_3 \left[(\text{Tr}_2 \mathbb{Q}^{(2,3)})^2 \right] + \frac{5}{8} (\text{Tr}_3 \text{Tr}_2 \mathbb{Q}^{(2,3)})^2 \right] + \mathcal{M}^{[01\dots 00]} \quad (3.19)$$

Had we chosen $N = 2$, there would be no monopole deformation in (3.19). Renaming $\text{Tr}_2 \mathbb{Q}^{(2,3)}$ as the meson matrix \mathcal{Q} introduced in section 2, this would be the final result.

Move # 2. We glue (3.18) back to $T[\text{SU}(N + 1)]$, and move forward. On nodes (2) and (3), the theory is now described by the modified quiver

$$\gamma_2, \quad \begin{array}{c} \text{blue loop} \\ \circlearrowleft \\ \text{---} \text{---} \\ \text{---} \text{---} \\ \text{---} \text{---} \\ \square \end{array} \quad (3.20)$$

The superpotential includes the terms

$$W_{\text{def}}^{T[\text{SU}(4)]} \supset W_{\text{eff}}^{T[\text{SU}(3)]} + \mathcal{W}_3 + \sum_{a=1}^8 \phi^a \text{Tr}_3 \left[T^a \left(\text{Tr}_4 \mathbb{Q}^{(3,4)} - \text{Tr}_2 \mathbb{Q}^{(2,3)} \right) \right] \quad (3.21)$$

The gauged matter content attached at node (2) is again of the form (3.7), plus singlets. We dualize by replacing $\text{Tr}_2 \mathbb{Q}^{(2,3)} \rightarrow M_3$ and add the superpotential term $\gamma_3 \det M_3$. As before we study abelian and non abelian contributions separately. In the abelian sector we find,

$$\frac{1}{2}\varphi_2^+ \text{Tr}_3 M_3 + \frac{1}{3}\text{Tr} \Phi_3 \left[\text{Tr}_3 \text{Tr}_4 \mathbb{Q}^{(3,4)} - \text{Tr}_3 M_3 \right], \quad (3.22)$$

which upon performing the rotation

$$\varphi_3^- = \frac{1}{2}\varphi_2^+ - \frac{1}{3}\text{Tr} \Phi_3, \quad \varphi_3^+ = \frac{3}{2}\varphi_2^+ + \text{Tr} \Phi_3, \quad (3.23)$$

becomes

$$\varphi_3^- \left(\text{Tr} M_3 - \frac{1}{2}\text{Tr}_3 \text{Tr}_4 \mathbb{Q}^{(3,4)} \right) + \frac{1}{2 * 3} \varphi_3^+ \text{Tr}_3 \text{Tr}_4 \mathbb{Q}^{(3,4)}. \quad (3.24)$$

Very much as in move #1, the F-terms of $\phi_3^{a=1,\dots,8}$ and φ_3^- imply that $\langle M_3 \rangle$ has the same non abelian components of $\text{Tr}_4 \mathbb{Q}^{(3,4)}$ but differs in the trace. The solution for $\langle M_3 \rangle$ is

$$\langle M_3 \rangle = \text{Tr}_4 \mathbb{Q}^{(3,4)} - \frac{\text{Tr}_3 \text{Tr}_4 \mathbb{Q}^{(3,4)}}{3 * 2} \mathbb{I}_{3 \times 3} \quad (3.25)$$

By integrating out the massive fields, φ_3^- , $\phi_3^{a=1,\dots,8}$, and fluctuations of δM_3 , we obtain a low energy theory with light φ_3^+ and bifundamentals $\mathbb{Q}^{(3,4)}$,

$$\gamma_2, \gamma_3, \quad \begin{array}{c} \text{---} \circlearrowleft \text{---} \\ \text{---} \text{---} \square \end{array} \quad (3.26)$$

As in the previous case, we would like to express the superpotential couplings which are linear in γ_2 and γ_3 , in terms of traces over matrices in the adjoint of $U(4)$. When $\det M_3$ is expanded out in Tr_3 , both γ_2 and γ_3 terms can be rearranged by using the following formulas,

$$\text{Tr}_3 \left[(M_3)^2 \right] = \text{Tr}_4 \left[(\text{Tr}_3 \mathbb{Q}^{(3,4)})^2 \right] - \frac{3(\text{Tr}_3 \text{Tr}_4 \mathbb{Q}^{(3,4)})^2}{4 * k = 3} \quad (3.27)$$

$$\begin{aligned} \text{Tr}_3 \left[(M_3)^3 \right] &= \text{Tr}_4 \left[(\text{Tr}_3 \mathbb{Q}^{(3,4)})^3 \right] - \frac{3 \text{Tr}_3 \text{Tr}_4 \mathbb{Q}^{(3,4)}}{2 * k = 3} \text{Tr}_4 \left[(\text{Tr}_3 \mathbb{Q}^{(3,4)})^2 \right] \\ &\quad + \frac{5(\text{Tr}_3 \text{Tr}_4 \mathbb{Q}^{(3,4)})^3}{72} \end{aligned} \quad (3.28)$$

For the couplings to γ_2 we obtain

$$\begin{aligned} -\frac{1}{2} \text{Tr}_3 \left[(M_3)^2 \right] + \frac{5}{16} (\text{Tr}_3 M_3)^2 &= -\frac{1}{2} \text{Tr}_4 \left[(\text{Tr}_3 \mathbb{Q}^{(3,4)})^2 \right] + \frac{13(\text{Tr}_3 \text{Tr}_4 \mathbb{Q}^{(3,4)})^2}{64} \\ &\equiv p_{2,3} [\text{Tr}_4, \text{Tr}_3 \mathbb{Q}^{(3,4)}] \end{aligned} \quad (3.29)$$

and for the couplings to γ_3

$$\begin{aligned} \det M_3 &= \frac{1}{3} \text{Tr}_3 \left[(M^{(3)})^3 \right] - \frac{\text{Tr}_3 \text{Tr}_4 \mathbb{Q}^{(3,4)}/2}{2} \text{Tr}_3 \left[(M^{(3)})^2 \right] + \frac{(\text{Tr}_3 \text{Tr}_4 \mathbb{Q}^{(3,4)})^3/2^3}{6} \\ &= \frac{1}{3} \text{Tr}_4 \left[(\text{Tr}_3 \mathbb{Q}^{(3,4)})^3 \right] - \frac{5 \text{Tr}_3 \text{Tr}_4 \mathbb{Q}^{(3,4)}}{12} \text{Tr}_4 \left[(\text{Tr}_3 \mathbb{Q}^{(3,4)})^2 \right] + \frac{23(\text{Tr}_3 \text{Tr}_4 \mathbb{Q}^{(3,4)})^3}{216} \\ &\equiv p_{3,3} [\text{Tr}_4, \text{Tr}_3 \mathbb{Q}^{(3,4)}] \end{aligned} \quad (3.30)$$

In both cases, the final results can be expressed in terms of polynomials $p_{3,3}$ and $p_{2,3}$ in the variable $\text{Tr}_3 \mathbb{Q}^{(3,4)}$, which is indeed in the adjoint of $U(4)$. Collecting these contributions, the effective superpotential is determined by

$$W_{\text{eff}}^{T[\text{SU}(4)]} = \frac{1}{6} \varphi_3^+ \text{Tr}_4 \text{Tr}_3 \mathbb{Q}^{(3,4)} + \gamma_2 p_{2,3} [\text{Tr}_4, \text{Tr}_3 \mathbb{Q}^{(3,4)}] + \gamma_3 p_{3,3} [\text{Tr}_4, \text{Tr}_3 \mathbb{Q}^{(3,4)}] + \dots \quad (3.31)$$

where \dots stands for the remaining monopole superpotential $\mathcal{L}_{\{3,\dots,N-1\}}$.

Duality moves: from # 1 up to # $N - 1$. Repeating the reasoning in move #1, and #2, we proceed up to # $N - 1$. The final gauge theory, which we refer to as theory A , has quiver diagram

$$\gamma_2, \dots, \gamma_N, \quad \begin{array}{c} \text{---} \circlearrowleft \text{---} \\ \text{---} \text{---} \square \end{array} \quad (3.32)$$

and superpotential

$$W_A = \frac{1}{N!} \varphi_N^+ \text{Tr} \mathcal{Q} + \sum_{m=2}^N \gamma_m p_{m,N} [\text{Tr}, \mathcal{Q}] \quad (3.33)$$

where $\text{Tr}_N \mathbb{Q}^{(N,N+1)} = \mathcal{Q}$ is the meson matrix, and $p_{m,n}$ are polynomials generalizing (3.29) and (3.30) at each step. Recall that we did not turn on the monopole superpotential on the last gauge node, therefore (3.33) is the final result. Let us summarize the sequential confinement up to $\#N - 1$. In the order:

- 1) After each dualization, labelled hereafter by $k - 1$, we derived an equation for $\langle M_k \rangle$ which we solved explicitly. In each case, the non abelian components of $\langle M_k \rangle$ are fixed by the F-terms of $\phi^{a=1, \dots, k^2-1}$ to be equal to $\text{Tr}_{k+1} \mathbb{Q}^{(k,k+1)}$. As in move #1, and #2, the abelian equation turns out to be always:

$$\text{Tr} \langle M_k \rangle = \frac{1}{2} \text{Tr}_k \text{Tr}_{k+1} \mathbb{Q}^{(k,k+1)} \quad (3.34)$$

The solution for $\langle M_k \rangle$ is

$$\langle M_k \rangle = \text{Tr}_{k+1} \mathbb{Q}^{(k,k+1)} - \frac{\text{Tr}_k \text{Tr}_{k+1} \mathbb{Q}^{(k,k+1)}}{2k} \mathbb{I}_{k \times k} \quad (3.35)$$

- 2) Having found the solution (3.35), we integrate the massive fields at node k and we write the superpotential for the light fields. These are $\text{Tr}_k \mathbb{Q}^{(k,k+1)}$, $\varphi_+^{(k)}$ and the collection of $\{\gamma_m\}_{m=2}^k$. This step is the most involved, since it requires rearranging the expression of $\{\det_m\}_{m=2}^k$ in terms of traces. The final result is packaged into the polynomials $p_{m,k}$. The structure of traces of such polynomials is fixed, i.e. by construction it coincides with that of \det_m in its Laplace expansion. In particular,

$$p_{m,k}[\text{Tr}_{k+1}, O] = \sum_{n_1, \dots, n_m} c_{\{n_1, \dots, n_m\}}^k [\text{Tr}_{k+1} O^1]^{n_1} [\text{Tr}_{k+1} O^2]^{n_2} \dots [\text{Tr}_{k+1} O^m]^{n_m} \quad (3.36)$$

where $O = \text{Tr}_k \mathbb{Q}^{(k,k+1)}$, and the sum runs over all m -tuple $n_1, \dots, n_m \geq 0$ which solve the constraint $\sum_{l=1}^m n_l = m$.⁶ From the original \det_m formula, the polynomials $p_{m,k}$ inherit the property of having degree m in O . However, powers of $\langle M_k \rangle$ will produce an admixture of powers of O , therefore a generic coefficients c^k will depend on k in a non trivial way. Only the top element $\text{Tr} O^m$ has coefficient fixed to be $c_{\{0^{m-1}, 1\}}^k = (-1)^{m-1}/m$ from the original \det_m formula. Perhaps, the best description of the coefficients c^k is given in terms of recursion relations. For illustration we quote

⁶The expression of $c_{\{n_1, \dots, n_m\}}^k$ in the case of \det_m is: $c_{\{n_1, \dots, n_m\}}^k \rightarrow (-)^m \prod_{l=1}^m \frac{(-l)^{-n_l}}{n_l!}$, and it is independent of k .

actually be written, more suggestively, in terms of the Jordan matrix

$$\mathbb{J}_N \oplus \mathbb{J}_1 = \left[\begin{array}{c|c} \mathbb{J}_N & \mathbf{0}_{1 \times N} \\ \hline \mathbf{0}_{N \times 1} & \mathbf{0}_{1 \times 1} \end{array} \right], \quad \mathbb{J}_N = \underbrace{\begin{pmatrix} 0 & 1 & \dots & \dots & 0 \\ 0 & 0 & 1 & \dots & 0 \\ \vdots & \vdots & & & \vdots \\ 0 & 0 & \dots & 0 & 0 \end{pmatrix}}_N \quad (3.41)$$

where \mathbb{J}_k is a single Jordan block of size k and zero eigenvalue. It follows that $\mathcal{L}_{\{1, \dots, N-1\}}^T$ is mirror to a nilpotent mass deformation for the meson \mathcal{P}_{ij} . By introducing the vectors

$$P^{(N+1, N)} = (p_1, p_2, \dots, p_{N+1}) \quad \tilde{P}^{(N+1, N)} = \begin{pmatrix} \tilde{p}_1 \\ \tilde{p}_2 \\ \vdots \\ \tilde{p}_{N+1} \end{pmatrix} \quad (3.42)$$

we find indeed

$$\mathcal{L}_{\{1, \dots, N-1\}}^{T\vee} = \text{Tr}_{N+1} [\mathbb{J}_N \oplus \mathbb{J}_1 \cdot \mathcal{P}] = \tilde{p}_2 \cdot p_1 + \dots + \tilde{p}_N \cdot p_{N-1}. \quad (3.43)$$

and the total superpotential is thus

$$W_{\text{def}}^{T\vee} = \mathcal{L}_{\{1, \dots, N-1\}}^{T\vee} + \sum_{k=1}^N \text{Tr}_k \left[\Omega_k \left(\text{Tr}_{k+1} \mathbb{P}^{(k+1, k)} - \text{Tr}_{k-1} \mathbb{P}^{(k, k-1)} \right) \right]. \quad (3.44)$$

The discussion next will closely follow [13].

The F-term equations of $\tilde{p}_{a=2, \dots, N}$ and $p_{b=1, \dots, N-1}$ are non trivial due to the mass deformation. Let us begin from the F-terms of the fields $\tilde{p}_{a=2, \dots, N}$, which read

$$p_{a-1} + \Omega_N p_a = 0 \quad (3.45)$$

The solution is expressed in terms of p_N as follows:

$$\langle p_b \rangle = (-)^{N-b} \underbrace{\Omega_N \dots \Omega_N}_{N-b \text{ times}} p_N \quad b = 1, \dots, N-1. \quad (3.46)$$

Equivalently, the F-terms of the fields $p_{b=1, \dots, N-1}$ are solved by

$$\langle \tilde{p}_a \rangle = (-)^{a-1} \tilde{p}_1 \underbrace{\Omega_N \dots \Omega_N}_{a-1 \text{ times}} \quad a = 2, \dots, N \quad (3.47)$$

On the vacuum $p_b \rightarrow \langle p_b \rangle + \delta p_b$, and $\tilde{p}_a \rightarrow \langle \tilde{p}_a \rangle + \delta \tilde{p}_a$, the pair of field (\tilde{p}_1, p_N) , and $(p_{N+1}, \tilde{p}_{N+1})$ do not get a mass terms from the deformation (3.43), thus they remain in the low energy spectrum.⁸ The effective superpotential for these light fields is

$$W_{\text{eff}}^{T\vee} = (-)^{N-1} \left[\tilde{p}_1 \underbrace{\Omega_N \dots \Omega_N}_N p_N \right] + \tilde{p}_{N+1} \Omega_N p_{N+1} \quad (3.48)$$

⁸Notice that we started with $2N(N+1)$ d.o.f in the bifundamentals P and \tilde{P} . Then we have N mass (terms) for each of the $N-1$ terms in \mathcal{L}_B . So $2N(N+1) - 2N(N-1) = 4N$ fields are light.

The low energy theory is then described by the quiver,

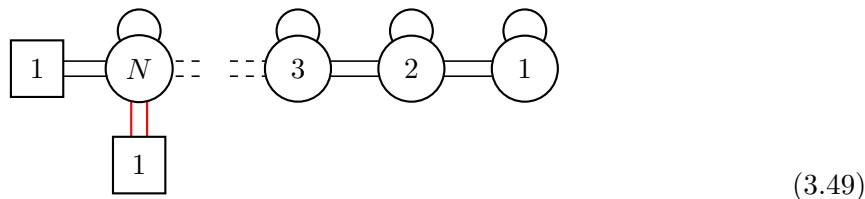

where we have isolated the fields $(d, \tilde{d}) \equiv (p_1, \tilde{p}_N)$ on the bottom of the diagram. Compared to the tail, these fields are the ones with a special superpotential interaction. The matrix $\mathbb{P}^{(1,N)}$ is now truncated to a one flavor component $p_{N+1}\tilde{p}_{N+1}$, and the total superpotential of theory B is

$$\begin{aligned}
 W_B = & (-)^{N-1} \left[\tilde{d} \underbrace{\Omega_N \cdots \Omega_N}_N d \right] + \tilde{p}_{N+1} \Omega_N p_{N+1} - \text{Tr}_N \left[\Omega_N \text{Tr}_{N-1} \mathbb{P}^{(N,N-1)} \right] \\
 & + \sum_{k=1}^{N-1} \text{Tr}_k \left[\Omega_k \left(\text{Tr}_{k+1} \mathbb{P}^{(k+1,k)} - \text{Tr}_{k-1} \mathbb{P}^{(k,k-1)} \right) \right]
 \end{aligned} \tag{3.50}$$

From the expression of W_B we deduce that the R-charge assignment is modified compared to $T[\text{SU}(N+1)]^\vee$. The newly generated term, $\tilde{d}\Omega^N d$, implies

$$R[\Omega_k] = 2r; \quad R[P] = R[\tilde{P}] = (1-r); \quad R[d] = R[\tilde{d}] = 1-Nr \tag{3.51}$$

where $R[\Omega_k] + R[P] = 2$. Consequently

$$R[\tilde{d} \underbrace{\Omega_N \cdots \Omega_N}_i d] = 2(1-r(N-i)). \tag{3.52}$$

We then have the following map between the singlets of theory A and dressed mesons of theory B:

$$\gamma_1 \leftrightarrow \tilde{d} \underbrace{\Omega_N \cdots \Omega_N}_{N-1 \text{ times}} d \quad ; \quad \begin{cases} \gamma_2 \leftrightarrow \tilde{d} \underbrace{\Omega_N \cdots \Omega_N}_{N-2 \text{ times}} d \\ \vdots \\ \gamma_N \leftrightarrow \tilde{d} d \end{cases} \tag{3.53}$$

The duality between theories A and B is a particular case of the SQCD mirror dual discussed in [13] with a minor difference, i.e. we have kept the fields γ_i on the side of theory A.

3.3 Theory C: nilpotent Higgsing from monopoles

The theory $FFT[\text{SU}(N+1)]^\vee$ introduced section 2.2 is described by the quiver

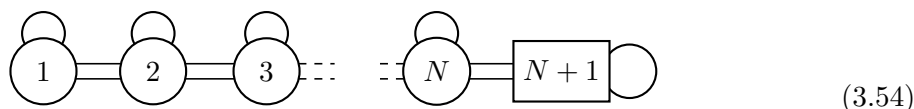

where we denoted the bifundamentals on each link by S and \tilde{S} , the adjoint chiral on each gauge node by Ψ , and finally the flipping fields by F_{ij}^n and $F_{ij}^{\mathcal{S}}$. The deformation $\mathcal{L}_{\{1,\dots,N-1\}}^{\vee}$ in $T[\mathrm{SU}(N+1)]^{\vee}$ maps in $FFT[\mathrm{SU}(N+1)]^{\vee}$ to

$$\mathcal{L}_{\{1,\dots,N-1\}}^{FFT^{\vee}} = \mathrm{Tr}_{N+1} \left[\mathbb{J}_N \oplus \mathbb{J}_1 \cdot F_{ij}^{\mathcal{S}} \right]. \quad (3.55)$$

The total superpotential is then

$$\begin{aligned} W_{\mathrm{def}}^{FFT^{\vee}} &= W^{FFT^{\vee}} + \mathcal{L}^{FFT^{\vee}} \\ W^{FFT^{\vee}} &= \sum_{k=1}^N \mathrm{Tr}_k \left[\Psi_k \left(\mathrm{Tr}_{k+1} \mathbb{S}^{(k,k+1)} - \mathrm{Tr}_{k-1} \mathbb{S}^{(k-1,k)} \right) \right] - \mathcal{S}_{ij} F_{ij}^{\mathcal{S}} - n_{ij} F_{ij}^n \end{aligned} \quad (3.56)$$

It will be convenient to momentarily modify our notation, and denote $F_{ij}^{\mathcal{S}}$ by Ψ_{N+1} . Then $\mathcal{S}_{ij} F_{ij}^{\mathcal{S}}$ fits with the pattern of the $\mathcal{N} = 4$ superpotential, and will allow us to display some recursions in a neat way.

We first consider the F-term of Ψ_{N+1} , which set

$$\mathrm{Tr}_N \mathbb{S}^{(N,N+1)} = +\mathbb{J}_N \oplus \mathbb{J}_1 \quad (3.57)$$

This equation shows that the bifundamentals on the last link of the tail acquire a non trivial vev.⁹ By definition, our bifundamentals are rectangular matrices. However, it is convenient to describe the vev in terms of square matrices where we specify which column/row has to be dropped. In this way, the solution of (3.57) is

$$\begin{aligned} \langle \tilde{\mathcal{S}}^{(N,N+1)} \rangle &= \mathbb{J}_N \oplus \mathbb{J}_1 && \text{drop the last column} \\ \langle \mathcal{S}^{(N,N+1)} \rangle &= (\mathbb{J}_1 \oplus \mathbb{I}_{N-1}) \oplus \mathbb{J}_1 && \text{drop the last row} \end{aligned} \quad (3.58)$$

Up to gauge and flavor rotations, the natural strategy to solve an equation of the form (3.57) is to take $\langle \tilde{\mathcal{S}} \rangle$ equal to the nilpotent vev on the r.h.s, and $\langle \mathcal{S} \rangle$ such that the equation is satisfied. In particular, $\langle \mathcal{S} \rangle$ has an identity block of rank $N - 1$ [34]. The solution when $N = 1$ reduces to zero, since there is no monopole potential in this case.

The F-terms of the fields $\Psi_{k \leq N}$ have two types of contributions. One is coming from the superpotential of the tail, i.e. $W^T[\Psi, \mathbb{S}]$, and a second one originates from the coupling $n_{ij} F_{ij}^n$: indeed, recall from the definition (2.8) that the monopole matrix has traceless diagonal components of the form $\mathrm{Tr} \Psi_k \mathcal{D}_k$. We will study a vacuum for which $\langle F_{ij}^n \rangle = 0$. Therefore the F-term of Ψ^k will be

$$\mathrm{Tr}_{k-1} \mathbb{S}^{(k-1,k)} = \mathrm{Tr}_{k+1} \mathbb{S}^{(k,k+1)} \quad (3.59)$$

Reading (3.59) from right to left, we conclude that the nilpotent vev (3.58) propagates along the quiver, from the last node towards the left. The solution of this recursion is

$$\begin{aligned} \langle \tilde{\mathcal{S}}^{(k-1,k)} \rangle &= \mathbb{J}_1 \oplus \mathbb{J}_{k-1} && \text{drop the first column} \\ \langle \mathcal{S}^{(k-1,k)} \rangle &= \mathbb{J}_1 \oplus (\mathbb{J}_1 \oplus \mathbb{I}_{k-2}) && \text{drop the first row} \end{aligned} \quad (3.60)$$

Note that for $k > 2$ the vev $\langle \tilde{\mathcal{S}}^{(k-1,k)} \rangle$ is always next to a maximal Jordan matrix \mathbb{J}_k . At the terminating value $k = 2$ both vevs vanish. These correspond to the bifundamentals on the first link (1, 2).

⁹Let us recall that in matrix notation, with standard multiplication, our definitions reduce to $\mathrm{Tr}_k \mathbb{S}^{(k,k+1)} = \tilde{\mathcal{S}}^{(k,k+1)} \cdot \mathcal{S}^{(k,k+1)}$, and $\mathrm{Tr}_k \mathbb{S}^{(k-1,k)} = \mathcal{S}^{(k-1,k)} \cdot \tilde{\mathcal{S}}^{(k-1,k)}$

Nilpotent vevs. A supersymmetric nilpotent vev should satisfy the F-terms of the bifundamentals, and finally D-terms. In matrix notation, the F -terms of the bifundamentals are

$$\tilde{S}^{(k,k+1)}\Psi_k = \Psi_{k+1}\tilde{S}^{(k,k+1)} \tag{3.61}$$

$$\Psi_k S^{(k,k+1)} = S^{(k,k+1)}\Psi_{k+1} \tag{3.62}$$

These equations put constraints on the fields Ψ_k , and before proceeding, let us recall that an additional constraint comes from the F-terms equations for the diagonal generators of F_{ij}^n , which imply the condition $\text{Tr}\Psi_k = 0$ for any $k \leq N$.

A trivial solution to (3.62) is $\langle\Psi_k\rangle = 0$ for any k . However, this solution will not be consistent with vanishing of D-terms, as we now explain.

Notice that equations (3.61) and (3.62) don't fix a solution, rather they impose a constraint on Ψ_{k+1} which depends on $S^{(k,k+1)}$, $\tilde{S}^{(k,k+1)}$ and Ψ_k . In this new recursion, the starting point is the beginning of the tail, i.e. the U(1) gauge node, and the first link (1, 2). Consistency of this recursion requires that the solution in the case of $T[\text{SU}(k)]$ uplifts to $T[\text{SU}(N+1)]$ for any $k \leq N$. The study of the first few cases will be enough to understand the nilpotent vev in the adjoint sector.

Consider $T[\text{SU}(2)]$. The D-term on the U(1) gauge node is

$$S^R S^{R\dagger} - \tilde{S}^{R\dagger} \tilde{S}^R = \xi_1, \quad R = (1, 2), \tag{3.63}$$

with ξ_1 an FI parameter. This equation reduces always to $\xi_1 = 0$, because $\langle S^{(1,2)} \rangle = \langle \tilde{S}^{(1,2)} \rangle = 0$. The solution is then compatible with $\langle\Psi_1\rangle = 0$. From equations (3.61) and (3.62) it follows $\langle\Psi_2\rangle = 0$, and we are back to the nilpotent vev for the flipping fields we started with, for this case.

Consider now $T[\text{SU}(3)]$. The D-term on the U(2) gauge node is

$$S^R S^{R\dagger} - \tilde{S}^{R\dagger} \tilde{S}^R + S^{L\dagger} S^L - \tilde{S}^L \tilde{S}^{L\dagger} = [\Psi_2, \Psi_2^\dagger] + \xi_2 \mathbb{I}_2, \quad \begin{cases} R = (2, 3) \\ L = (1, 2) \end{cases}. \tag{3.64}$$

A short computation shows that the terms labelled by 'R' cancel each other. Since $\langle S^{(1,2)} \rangle = \langle \tilde{S}^{(1,2)} \rangle = 0$, the terms labelled by 'L' do not contribute. The case of $T[\text{SU}(3)]$ is again special and the solution $\langle\Psi_2\rangle = 0$, $\xi_2 = 0$ is consistent. In particular $T[\text{SU}(2)]$ uplifts to $T[\text{SU}(3)]$. Finally equations (3.61) and (3.62) imply the relations

$$\Psi_3 \tilde{S}^{(2,3)} = \begin{bmatrix} 0 & 0 \\ 0 & 0 \\ 0 & 0 \end{bmatrix}, \quad S^{(2,3)} \Psi_3 = \begin{bmatrix} 0 & 0 & 0 \\ 0 & 0 & 0 \end{bmatrix}. \tag{3.65}$$

These equations do not fix all the components of $\langle\Psi_3\rangle$. The trivial solution is possible, but we claim that the actual solution, compatible with $T[\text{SU}(4)]$, is a nilpotent vev for $\langle\Psi_3\rangle$, i.e.

$$\langle\Psi_3\rangle = \mathbb{J}_2 \oplus \mathbb{J}_1. \tag{3.66}$$

Again, we are back to the nilpotent vev for the flipping fields we started with.

The lesson from the previous case is the following: by moving forward to the right of a longer quiver tail we will have to deal with D-term equations of the form

$$S^R S^{R\dagger} - \tilde{S}^{R\dagger} \tilde{S}^R + S^{L\dagger} S^L - \tilde{S}^L \tilde{S}^{L\dagger} = [\Psi_k, \Psi_k^\dagger] + \xi_k \mathbb{I}_k, \quad (3.67)$$

for any $R = (k, k + 1)$ and $L = (k - 1, k)$. We show in appendix A that terms labelled by ‘R’ always cancel each other. On the other hand, terms labelled by ‘L’ do not, and give a non zero commutator $[\Psi_k, \Psi_k^\dagger]$.

The solution of F- and D-terms induced by the next-to-maximal nilpotent vev (3.57) is:

$$\langle \Psi_k \rangle = \mathbb{J}_1 \oplus \mathbb{J}_{k-1}, \quad \langle \Psi_{N+1} \rangle = \mathbb{J}_N \oplus \mathbb{J}_1. \quad (3.68)$$

It is important to point out that D-terms equations are automatically solved by the SU(2) relation, $\rho_k(\sigma_3) = [\Psi_k, \Psi_k^\dagger]$ which follows from the construction of the nilpotent vev. In our case the embedding ρ_k of the σ_3 element is

$$\rho_k(\sigma_3) \equiv S^{L\dagger} S^L - \tilde{S}^L \tilde{S}^{L\dagger} = \text{diag}(0, -1, 0_{k-3}, +1), \quad L = (k - 1, k). \quad (3.69)$$

In this solution, the FI parameters ξ_k are zero for any k .

The list of scalar vevs includes the real scalars in the vector multiplets, which do not play any role, i.e. $\langle \sigma^k \rangle = 0$.

The low energy theory. Given the nilpotent vevs found in the previous section, we can explicitly study the Higgs mechanism and obtain the massless field content.

Let us begin from the gauge sector. It is useful to recall that a generic gauge transformation on the quiver acts on the matter fields in the following fashion:

$$G[\{\Psi_k, S^{(k,k+1)}, \tilde{S}^{(k,k+1)}\}_{k=1}^N] = \bigoplus_{k=1}^N G_k \quad (3.70)$$

where G_k is the action restricted to a single gauge node $U(k)$. Taking the connection

$$\mathcal{A}_k = \sum_{a=1}^{k^2} g_a^k T^a \quad (3.71)$$

we will find

$$G_k = \sum_{a=1}^{k^2} g_k^a \left([T^a, \Psi_k], -S^{(k-1,k)} T^a, T^a S^{(k,k+1)}, T^a \tilde{S}^{(k-1,k)}, -\tilde{S}^{(k,k+1)} T^a \right) \quad (3.72)$$

where we listed all the different matter representations.

A broken generator does not leave the vev invariant, therefore $T_{\mathfrak{R}}^a \langle z \rangle \neq 0$. Here z stands (at least) for one among all the fields of the tail and the various representation have been indicated by \mathfrak{R} . Unbroken generators annihilate the vevs. The determination of unbroken generators is equivalent to the study of the kernel of the mass matrix obtained from the expansion of the covariant derivatives. More details on such a matrix are collected in the appendix A. In conclusion, fixing a basis of T^a we find a solution for the coefficients

g_k^a , which corresponds to a single unbroken generator \mathcal{A}_k for gauge group $U(k)$. Its explicit form is very simple,

$$\mathcal{A}_k \equiv \text{diag}(1, \underbrace{0, \dots, 0}_{k-1 \text{ zeros}}) . \quad (3.73)$$

As far as the gauge groups are concerned, the quiver (3.54) is Higgsed to

$$\underbrace{\textcircled{1} \quad \textcircled{1} \quad \textcircled{1} \quad \dots \quad \textcircled{1}}_{N \text{ nodes}} \quad (3.74)$$

The next task will be to deduce the massless matter content by the studying the kernel of the mass matrix for all the scalar fields. We focus on the chiral multiplets.¹⁰ The mass matrix is hermitian and admits an eigenvector decomposition, which we split into $\ker \oplus \ker^\perp$, where the latter describes massive fields. The massless sector will contain bifundamentals charged under (L, R) gauge groups, fundamentals and anti-fundamentals charged under a single gauge group, other massless neutral fields, and finally Goldstone bosons. The ‘physical’ massless fields of the IR theory correspond to those vectors in \ker which cannot be written only as linear combination of Goldstone bosons. On the other hand, a physical configuration might still have components along the directions parametrized by the Goldstone bosons.

The deformation \mathcal{L}^{FFT^\vee} breaks explicitly the non abelian flavor symmetry, therefore all the Goldstone bosons we will find correspond only to the action of broken gauge generators on the nilpotent vev. In the field variables S , \tilde{S} , and Ψ , these Goldstone bosons are described by independent field configurations, of the form,

$$G_k = \sum_{a=1}^{k^2-1} g_k^a \left([T^a, \langle \Psi_k \rangle], -\langle S^{(k-1,k)} \rangle T^a, T^a \langle S^{(k,k+1)} \rangle, T^a \langle \tilde{S}^{(k-1,k)} \rangle, -\langle \tilde{S}^{(k,k+1)} \rangle T^a \right)$$

for parameters $\{g^{a=1, \dots, k^2-1}\}_{k=1}^N$ corresponding to broken gauge generators.

We computed the mass matrix generated from the superpotential. Holomorphy implies the existence of $\sum_{k=2}^N (k^2 - 1) = \frac{1}{6}(N-1)N(2N+5)$ complex Goldstone bosons. The resulting \ker can be quite cumbersome at first, but the physical massless fields can be brought to a simple form by taking linear combinations with Goldstone bosons, i.e. setting to zero unwanted components. We checked all our computations with computer algebra up to $N=6$. After all this work is done, we find that most of the final answer can be presented in a more intuitive way. This is the case for charged fields, as we now argue. IR flipping fields will have instead a more complicated description.

Let us begin from bifundamental fields in the abelian quiver (3.74), i.e. fields simultaneously charged under a left and right gauge node. Considering the UV $S^{(k,k+1)}$, we want

¹⁰Real scalar fields $\{\sigma^1 \dots \sigma^N\}$ in the vector multiples have the same mass matrix as the gauge fields. This follows from unbroken susy and it is obvious from a $4d$ perspective. In the $3d$ Lagrangian is manifests in matter couplings of the type $z^\dagger \sigma_{31}^2 z$. In particular, on the vacuum $\langle \sigma^k \rangle = 0$ there are no non trivial off-diagonal mass terms with chiral multiplets.

to select those components which transform non trivially under \mathcal{A}_k and \mathcal{A}_{k+1} , where the gauge field is given explicitly in (3.73). It is simple to see that the first row of $S^{(k,k+1)}$ transforms non trivially under \mathcal{A}_k , while the first column transforms non trivially under \mathcal{A}_{k+1} . For $k = 1, \dots, N-1$ the low energy bifundamentals, $s^{(k,k+1)}$ and $\tilde{s}^{(k,k+1)}$, embedded into $S^{(k,k+1)}$ and $\tilde{S}^{(k,k+1)}$, are indeed in the (1, 1) entry,

$$S^{(k,k+1)} \rightarrow \left[\begin{array}{c|c} s^{(k,k+1)} & 0_{1 \times k} \\ \hline 0_{k-1 \times 1} & 0_{k-1 \times k} \end{array} \right] \quad \tilde{S}^{(k,k+1)} \rightarrow \left[\begin{array}{c|c} \tilde{s}^{(k,k+1)} & 0_{1 \times k-1} \\ \hline 0_{k \times 1} & 0_{k \times k-1} \end{array} \right] \quad (3.75)$$

The nilpotent vev (3.60) restricted on the the first two gauge nodes is vanishing. Indeed both $S^{(1,2)} = (s^{(1,2)}, f_1)$ and $\tilde{S}^{(1,2)} = (\tilde{s}^{(1,2)}, \tilde{f}_1)^T$ are massless in the IR. However the fields f_1 and \tilde{f}_1 are not charged under the U(1) on the second gauge node, so they become a pair of fundamental/antifundamental attached to the first gauge node. On the flavor node at the end of the tail we also find a pair of fundamental/antifundamental fields, f_N and \tilde{f}_N . In the case of $S^{(N,N+1)}$ we know from previous discussion that f_N will lie on the first row, since this transforms under \mathcal{A}_N . However, differently from the bifundamentals $S^{(k,k+1)}$ in (3.75), the location of f_N inside $S^{(N,N+1)}$ depends on the form of the nilpotent vev (3.58). A similar reasoning holds for $\tilde{f}_N \subset \tilde{S}^{(N,N+1)}$. The solution is,

$$S^{(N,N+1)} \rightarrow \left[\begin{array}{c|c} 0_{1 \times N} & f_N \\ \hline 0_{N-1 \times N} & 0_{N-1 \times 1} \end{array} \right] \quad \tilde{S}^{(N,N+1)} \rightarrow \left[\begin{array}{c|c} 0_{N \times 1} & 0_{1 \times N-1} \\ \hline \tilde{f}_N & 0_{N \times N-1} \end{array} \right] \quad (3.76)$$

The IR quiver theory until now is described by the diagram

$$\boxed{1} \text{ --- } \underbrace{\left(\text{---} \bigcirc 1 \text{ ---} \bigcirc 1 \text{ ---} \dots \text{ ---} \bigcirc 1 \text{ ---} \right)}_{N \text{ nodes}} \text{ ---} \boxed{1} \quad (3.77)$$

We move on to the study of neutral fields. The simplest case is represented by singlet fields on each gauge node, which we denote by ψ_k . These are given by the following embedding: $\Psi_k = \text{diag}(\psi_k, 0^{k-1})$, $k = 1, \dots, N$, as it could have been anticipated. The analysis of IR massless fields originating from the flipping fields Ψ_{N+1} is less straightforward, and there is a novelty: it is not possible to localize such fields on components of Ψ_{N+1} , but the corresponding vectors in \ker will have components on both Ψ_{N+1} and $\Psi_{i \leq N}$. Furthermore, the latter cannot be eaten up by taking linear combinations with Goldstone bosons.

We begin by assuming $\Psi_{N+1} \in \text{U}(N+1)$ for simplicity, and we will obtain the case $\Psi_{N+1} \in \text{SU}(N+1)$, which is of interest for our duality web, by a minor modification. This procedure is instructive since it will have a counterpart in the next section.

Let us introduce first the IR fields $\Gamma_{i=2, \dots, N}$. In terms of components of Ψ_{N+1} , we find

$$\Psi_{N+1} \supset \left[\begin{array}{cccc|c} 0 & \Gamma_2 & \Gamma_3 & \dots & \Gamma_N & 0 \\ 0 & 0 & \Gamma_2 & \dots & \Gamma_{N-1} & 0 \\ \vdots & & & & \vdots & \vdots \\ \vdots & & & & \Gamma_2 & 0 \\ \hline 0 & 0 & 0 & 0 & 0 & 0 \\ 0 & 0 & 0 & 0 & 0 & 0 \end{array} \right] = \left[\Gamma_2 \mathbb{J}_N \oplus \Gamma_3 \mathbb{J}_N^2 \dots \oplus \Gamma_N \mathbb{J}_N^{N-1} \right] \oplus \mathbb{J}_1 \quad (3.78)$$

where the rewriting on the r.h.s. makes manifest that these fields parametrize nilpotent directions inside Ψ_{N+1} . The configuration (3.78) extends on the UV adjoint fields $\Psi_{i \leq N}$, as follows

$$\Psi_{N+1-k} \supset \mathbb{J}_1 \oplus \left[\Gamma_2 \mathbb{J}_{N-k}^{1+k} \oplus \Gamma_3 \mathbb{J}_{N-k}^{2+k} \dots \oplus \Gamma_{N-k} \mathbb{J}_{N-k}^{N-k-1} \right] \quad k = 1, \dots, N-2. \quad (3.79)$$

Matrices are multiplied a number of times defined by the upper index, i.e. $\mathbb{J}_{N-k}^\# = \mathbb{J}_{N-k} \dots \mathbb{J}_{N-k} \#$ times. For example, notice that Γ_2 extends backwards to Ψ_3 , Γ_3 extends backwards to Ψ_4 , and so on. (Ψ_1 and Ψ_2 vanish in this case.) On a similar footing we find the field Δ , which has the following UV embedding,

$$\Psi_{N+1} \supset \Delta [\mathbb{I}_N \oplus \mathbb{J}_1], \quad \Psi_{N+1-k} \supset \Delta [\mathbb{J}_1 \oplus \mathbb{I}_{N-k}] . \quad (3.80)$$

Finally, there are three other fields, Σ_\pm and δ . These ones are localized on specific components of Ψ_{N+1} ,

$$\left[\begin{array}{cc|c} 0_{1 \times N-1} & 0 & \Sigma_+ \\ 0_{2 \times N-1} & 0 & 0 \\ \vdots & \vdots & \vdots \\ 0_{N \times N-1} & 0 & 0 \\ \hline 0_{1 \times N-1} & \Sigma_- & \delta \end{array} \right] \quad (3.81)$$

The IR flipping fields presented so far have been obtained by refining the output of *ker*. We now explain how to see explicitly that these fields do not get a mass term from the superpotential. For each link (L, R) of the quiver, consider the mass terms coming from fluctuations $\delta\Psi_L$, $\delta\Psi_R$ and $\delta S^{(L,R)}$, on top of the nilpotent vev. We find

$$\begin{aligned} \delta W^{FFT^\vee} \supset \text{Tr} \left[\left(\langle \tilde{S}^{(L,R)} \rangle \delta\Psi_L - \delta\Psi_R \langle \tilde{S}^{(L,R)} \rangle \right) \delta S^{(L,R)} \right. \\ \left. + \left(\delta\Psi_L \langle S^{(L,R)} \rangle - \langle S^{(L,R)} \rangle \delta\Psi_R \right) \delta \tilde{S}^{(L,R)} \right] \end{aligned} \quad (3.82)$$

We have to show that when looking at the components of $\delta\Psi_{k \leq N+1}$ parametrized by $\Gamma_{i=2, \dots}$ or Δ , each term in (3.82) vanishes for any (L, R) . Indeed, because of the form of the nilpotent vev (3.60), the equation

$$\langle \tilde{S}^{(k,k+1)} \rangle \delta\Psi_k = \delta\Psi_{k+1} \langle \tilde{S}^{(k,k+1)} \rangle \quad k = 1, \dots, N, \quad (3.83)$$

$$\delta\Psi_k \langle S^{(k,k+1)} \rangle = \langle S^{(k,k+1)} \rangle \delta\Psi_{k+1} \quad k = 1, \dots, N. \quad (3.84)$$

are solved precisely by (3.78)–(3.79) and (3.80). Moreover, on the link $(N, N+1)$, this same computation shows that the directions parametrized by Σ_\pm and δ are also massless, since when we multiply by the vev, these matrix elements are shifted either to the right, or to the bottom, by two units, i.e. they disappear from the equations.

The case of interest, $\Psi_{N+1} \in \text{SU}(N+1)$, is quite simple to deduce. Indeed only the IR fields Δ and δ parametrize directions which overlap with the identity. Therefore, out of

these two, we should consider the traceless combination and drop the other. We associate to such a combination the IR field Γ_1 , whose UV embedding is

$$\Psi_{N+1} \supset \frac{\Gamma_1}{\sqrt{N^2+N}} \begin{bmatrix} \mathbb{I}_{N \times N} & 0 \\ 0 & -N \end{bmatrix} \quad \Psi_{N+1-k} \supset \frac{\Gamma_1}{\sqrt{N^2+N}} [\mathbb{J}_1 \oplus \mathbb{I}_{N-k}] . \quad (3.85)$$

Collecting all the fields, the final low energy theory, which we denote by Theory C, is described by the abelian quiver

$$\Gamma_1, \dots, \Gamma_N, \Sigma_{\pm} \quad (3.86)$$

A simple counting shows that we have determined $4(N+1)$ chiral fields.

3.4 The ABCD of monopole deformed $T[\text{SU}(N+1)]$

In this section we define theory D as the Aharony dual of theory A , and we show that the mirror of theory D is precisely theory C . Quite remarkably, mirror symmetry between $T[\text{SU}(N+1)] \leftrightarrow T[\text{SU}(N+1)]^\vee$ and $FFT[\text{SU}(N+1)] \leftrightarrow FFT[\text{SU}(N+1)]^\vee$ descends to mirror symmetry between AB and CD . The IR commutative diagram, initiated from $T[\text{SU}(N+1)]$ through the monopole deformation, is thus complete:

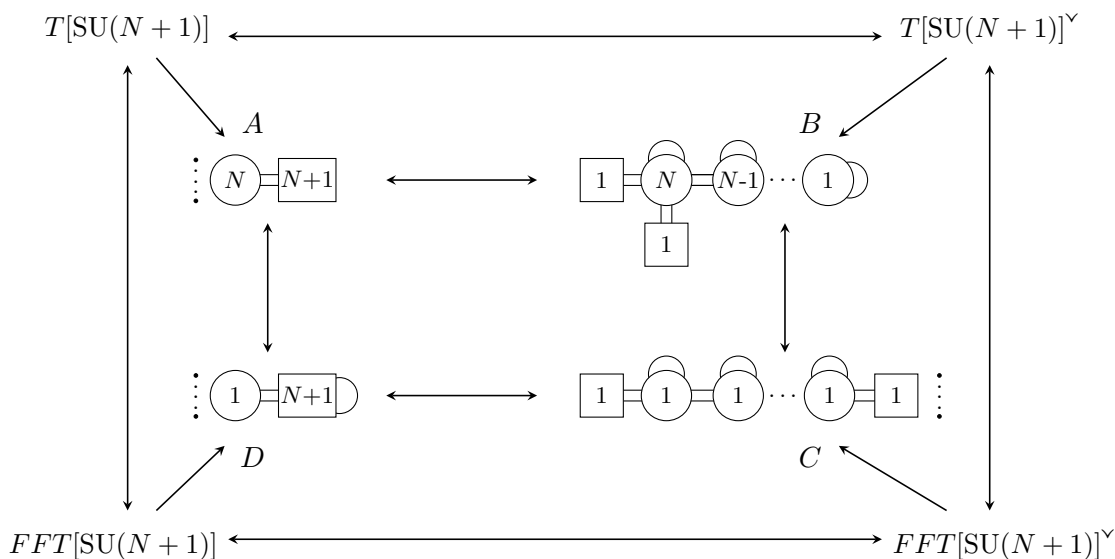

Let us remind that theory A is $U(N)$ SQCD with $N+1$ flavors coupled to additional singlets γ_m through the superpotential

$$W_A = - \sum_{m=1}^N \frac{(-)^m}{m} \gamma_m \text{Tr}_{N+1}[\mathcal{Q}^m]. \quad (3.87)$$

We apply Aharony duality [6] to Theory A and obtain Theory D , which is a $U(1)$ gauge theory with $N+1$ flavors U_i and \tilde{U}_j , flipping fields F_{ij}^U for the meson $\mathcal{U}_{ij} = U_i \tilde{U}_j$, and flipping

The mirror of theory D is completed once we map the superpotential W_D . In order to do so we should refine the map of the operators. Mirror symmetry would relate the meson \mathcal{U}_{ij} to the monopole matrix n_{ij} . But since the meson \mathcal{U}_{ij} is not traceless, there is a mismatch of representations we have to take care of. More precisely, we claim that the $SU(N+1)$ degrees of freedom of \mathcal{U}_{ij} are mirror to the monopole matrix n_{ij} , which is traceless, while the trace $\text{Tr}\mathcal{U}$ is in correspondence with δ . The rest of the dictionary is standard: the monopole fields m_{\pm} of theory D are mirror to the long meson $L_+ = \prod_{i=0}^N s_i$ and $L_- = \prod_{i=0}^N \tilde{S}_i$, and the flipping fields $F_{ij}^{\mathcal{U}}$, σ_{\pm} and θ_m are mapped to an equivalent number of singlets, F_{ij}^n , Σ'_{\pm} , and Γ'_m .

The superpotential W_D^{\vee} is

$$\begin{aligned}
 W_D^{\vee} = & \sum_{i=0}^N s^{(i,i+1)} \delta \tilde{s}^{(i,i+1)} + \sum_{i=1}^N \psi_i (s^{(i,i+1)} \tilde{s}^{(i,i+1)} - s^{(i-1,i)} \tilde{s}^{(i-1,i)}) \\
 & + L_{\pm} \Sigma'_{\pm} + (\delta \text{Tr} F_{ij}^n + n_{ij} F_{ij}^n) - \sum_{m=1}^N \frac{(-)^m}{m} \Gamma'_m \text{Tr} \left[\underbrace{F_{ij}^n \dots F_{ij}^n}_{m \text{ times}} \right] \quad (3.93)
 \end{aligned}$$

The terms $\Gamma'_1 \text{Tr} F_{ij}^n$ and $\delta \text{Tr} F_{ij}^n$ combine into the mass term $(\Gamma'_1 + \delta) \text{Tr} F_{ij}^n$. Then, both $(\Gamma'_1 + \delta)$ and $\text{Tr} F_{ij}^n$ can be integrated out, while the field $\Gamma_1 \equiv (\Gamma'_1 - \delta)$ remains massless. After trivial redefinitions,

$$\begin{aligned}
 W_D^{\vee} = & \sum_{i=0}^N s^{(i,i+1)} \Gamma_1 \tilde{s}^{(i,i+1)} + \sum_{i=1}^N \psi_i (s^{(i,i+1)} \tilde{s}^{(i,i+1)} - s^{(i-1,i)} \tilde{s}^{(i-1,i)}) \\
 & + L_{\pm} \Sigma_{\pm} + n_{ij} F_{ij}^n - \sum_{m=2}^N \frac{(-)^m}{m} \Gamma_m \text{Tr} \left[\underbrace{F_{ij}^n \dots F_{ij}^n}_{m \text{ times}} \right] \equiv W_C \quad (3.94)
 \end{aligned}$$

The notation ψ_i , $s^{(i,i+1)}$, F_{ij}^n and n_{ij} should be familiar from the study of theory C. We have found $F_{ij}^n \in SU(N+1)$, $n_{ij} \in SU(N+1)$, and other $4(N+1)$ fields. These corresponds to bifundamentals, and fundamentals on the right and left of (3.92), in addition to the singlets $\psi_{i=1..N}$, the fields Σ_{\pm} , and $\Gamma_{i=1..N}$. Remarkably, this number is precisely the same number we determined in section 3.3 from the nilpotent Higgsing.

We have not discussed how the deformation \mathcal{L}^{FFT} brings $FFT[SU(N+1)]$ down to Theory D . This would require a study of the Higgsing process on monopole fields, a challenge which is behind the immediate scope of this paper.

Operator map. We conclude this section by recording the chiral ring generators which we are able to map across the four dual frames $ABCD$:

- Theory A:
 - Two monopoles with $R[\mathcal{M}_A^{\pm}] = 2 - r(N+1)r$
 - HB moment map, $(N+1) \times (N+1)$ traceless, with $R[\Pi_A^Q] = 2r$
 - Flipping fields with $R[\gamma_m] = 2 - 2rm$, $m = 1, \dots, N$

- Theory B :
 - Two mesons with $R[d\tilde{p}_{N+1}] = R[\tilde{d}p_{N+1}] = 2 - (N + 1)r$
 - Monopoles matrix, $(N + 1) \times (N + 1)$ traceless, with $R[\mathcal{N}_B] = 2r$
 - Dressed mesons with $R[\tilde{d}\Omega^i d] = 2(1 - r(N - i))$, $i = 0, \dots, N - 1$
- Theory C :
 - Two flipping fields with $R[\Sigma^\pm] = 2 - r(N + 1)$
 - Flipping fields, $(N + 1) \times (N + 1)$ traceless, with $R[F_C^u] = 2r$
 - Flipping fields with $R[\Gamma_m] = 2 - 2rm$, $m = 1, \dots, N$
- Theory D :
 - Two Flipping fields with $R[\sigma^\pm] = 2 - (N + 1)r$
 - Flipping fields, $(N + 1) \times (N + 1)$ traceless, with $R[F_D^u] = 2r$
 - Flipping fields with $R[\theta_m] = 2 - 2rm$, $m = 1, \dots, N$.

4 Partition functions

In this section we study partition functions of our theories on the squashed three-sphere S_b^3 , and we show that they are all equal as we move in the commutative diagram:

$$\begin{array}{ccc}
 T[\mathrm{SU}(N+1)] & \longleftrightarrow & T[\mathrm{SU}(N+1)]^\vee \\
 \swarrow & & \searrow \\
 & A \longleftrightarrow B & \\
 \uparrow & \uparrow \downarrow & \uparrow \\
 & D \longleftrightarrow C & \\
 \downarrow & & \downarrow \\
 FFT[\mathrm{SU}(N+1)] & \longleftrightarrow & FFT[\mathrm{SU}(N+1)]^\vee
 \end{array} \tag{4.1}$$

We follow the notation of [37]. We introduce the vectors $\vec{M} = (M_1, \dots, M_{N+1})$ and $\vec{T} = (T_1, \dots, T_{N+1})$ of real mass parameters for the flavor and topological symmetries and the real mass m_A associated to the $U(1)_A$ symmetry. We also define $Q \equiv b + b^{-1}$, where b is the squashing of the three-sphere. Then, the partition function of $T[\mathrm{SU}(N + 1)]$ can be obtained by the following set of rules:

- Each one of the N gauge nodes, labelled by (k) with $k = 1, \dots, N$, carries a measure $dx^{(k)} = \prod_{i=1}^k dx_i^{(k)} / k!$ where the set $\{x_i^{(k)}\}$ represents the Coulomb Branch coordinates on the localizing locus.

- The contribution from vector multiplets and adjoint chirals attached to a node (k) is

$$Z_{\text{vec}}^{(k)} = \prod_{i < j}^k \frac{1}{s_b \left(\frac{iQ}{2} \pm (x_i^{(k)} - x_j^{(k)}) \right)}, \quad (4.2)$$

$$Z_{\text{adj}}^{(k)} = \prod_{i,j}^k s_b \left(m_A \pm (x_i^{(k)} - x_j^{(k)}) \right). \quad (4.3)$$

- The contribution of bifundamentals on a link ($k, k + 1$) is

$$Z_{\text{bif}}^{(k,k+1)} = \prod_{i=1}^k \prod_{j=1}^{k+1} s_b \left(\frac{iQ}{4} - \frac{m_A}{2} \pm (x_i^{(k)} - x_j^{(k+1)}) \right). \quad (4.4)$$

As pointed out in [27], the partition function depends holomorphically on the combination of the real mass parameter m_A , and the coefficient determining the IR R-symmetry. Then, we will take $\text{Im}(m_A) = -\frac{Q}{2}\alpha$ with α parametrizing the mixing $R = C + H + \alpha(C - H)$. In this conventions, a chiral multiplet of R-charge r contributes with $s_b(\frac{iQ}{2}(1-r) - \dots)$ to the partition function [37], and from Z_{bif} and Z_{adj} we read off

$$R_{\text{bif}} = \frac{1 - \alpha}{2} = r, \quad R_{\Phi} = 1 + \alpha = 2(1 - r). \quad (4.5)$$

This is indeed the same assignment we discussed in section 2. Putting all together the partition function of the tail (2.1) is:

$$\mathcal{Z}^T[N, m_A; \vec{M}, \vec{T}] = e^{+2\pi i T_{N+1} \sum_{i=1}^{N+1} M_i} \int \prod_{k=1}^N dx^{(k)} e^{2\pi i \xi^{(k)} \sum_{i=1}^k x_i^{(k)}} Z_{\text{vec}}^{(k)} Z_{\text{adj}}^{(k)} Z_{\text{bif}}^{(k,k+1)} \quad (4.6)$$

where $\xi^{(k)} = T_k - T_{k+1}$, and $\vec{x}^{(N+1)} \equiv \vec{M}$ a constant vector, i.e. not integrated over.

The exponential factors in (4.6) correspond in the field theory to mixed Chern-Simons terms. Those inside the integral couple the topological and the gauge symmetry, while those in front of the integral are mixed background Chern-Simons terms coupling the topological and the flavor symmetry. These terms are related to contact terms in the two-point function of the associated conserved currents and their importance in the context of dualities has been pointed out in [38, 39] (see also for a review [40]).

Finally, the partition function of $T[\text{SU}(N + 1)]$ is a specification of \mathcal{Z}^T to the case $\sum_{i=1}^{N+1} T_i = \sum_{i=1}^{N+1} M_i = 0$, consistent with the non-abelian global symmetry $\text{SU}(N + 1)_{\text{flavor}} \times \text{SU}(N + 1)_{\text{top}}$. Notice that when this condition is imposed the contribution of Chern-Simons contact terms in (4.6) vanishes. However it is important to keep track of all contact terms when gauging a flavor symmetry, because in such a case the background Chern-Simon terms become dynamical, and play a crucial role.

4.1 Difference operators and dual partition functions

In this section we consider the outer diagram (4.1), in which $T[\text{SU}(N + 1)]$ is dual to $\text{FFT}[\text{SU}(N+1)]$ and mirror to $T[\text{SU}(N+1)]^\vee$, and show that the various partition functions are all equal, as function of the global symmetry parameters: M_p , T_p and m_A .

The partition function $T[\text{SU}(N+1)]^\vee$ is related in a straightforward way to \mathcal{Z}^T . The action of mirror symmetry on $T[\text{SU}(N+1)]$ defines

$$\mathcal{Z}^{T^\vee}[N, m_A; \vec{M}, \vec{T}] = \mathcal{Z}^T[N, -m_A; \vec{T}, \vec{M}]. \quad (4.7)$$

In particular \mathcal{Z}^{T^\vee} is given by the same matrix integral as $T[\text{SU}(N+1)]$, where masses M_a and FI parameters T_a are swapped, and the sign of the axial mass m_A inverted. This is consistent with the fact that mirror symmetry exchanges HB and CB.

Our prescription for the partition function of $F\!F\!T[\text{SU}(N+1)]$ is

$$\mathcal{Z}^{F\!F\!T}[N, m_A; \vec{M}, \vec{T}] = K[\vec{M}, -m_A]K[\vec{T}, m_A]\mathcal{Z}^T[N, -m_A; \vec{M}, \vec{T}] \quad (4.8)$$

where

$$K[\vec{x}, m_A] = Z_{\text{adj}}^{(N)} = \prod_{i,j}^N s_b(m_A \pm (x_i - x_j)) = K[\vec{x}, -m_A]^{-1}. \quad (4.9)$$

The factor $K[\vec{x}, \pm m_A]$ are used to introduce the contribution of flipping fields $F_{ij}^{\mathcal{R}}$ and F_{ij}^m , for the moment map and the monopole, respectively. The two signs of m_A in $K[\vec{M}, -m_A]$ and $K[\vec{T}, m_A]$ are consistent with the fact that in $F\!F\!T[\text{SU}(N+1)]$ the HB flipping fields $F_{ij}^{\mathcal{R}}$ have R -charge $2r$, while the CB flipping fields F_{ij}^m have R -charge $2 - 2r$. Notice that the diagonal elements $i = j$ in the product $K[\vec{M}, -m_A]K[\vec{T}, m_A]$ simplify to unity. Therefore we can understand this product as the contribution of (singlets) adjoint fields in the $\text{SU}(N+1)_{\text{flavor}} \times \text{SU}(N+1)_{\text{top}}$.

Proving our dualities is equivalent to show that:

$$\mathcal{Z}^{T^\vee}[N, m_A; \vec{M}, \vec{T}] = \mathcal{Z}^T[N, -m_A; \vec{T}, \vec{M}] = \mathcal{Z}^T[N, m_A; \vec{M}, \vec{T}], \quad (4.10)$$

$$\begin{aligned} \mathcal{Z}^{F\!F\!T}[N, m_A; \vec{M}, \vec{T}] &= K[\vec{M}, -m_A]K[\vec{T}, m_A]\mathcal{Z}^T[N, -m_A; \vec{M}, \vec{T}] \\ &= \mathcal{Z}^T[N, m_A; \vec{M}, \vec{T}] \end{aligned} \quad (4.11)$$

Our proof is based on [11] where, building on the results of [33], it was shown that \mathcal{Z}^T is eigenfunctions of two sets of trigonometric Ruijsenaars-Schneider (RS) Hamiltonians. We introduce a first set of RS Hamiltonians,

$$\mathcal{H}_r(\vec{M}, m_A) = \sum_{I \subset \{1, \dots, n\}, |I|=r} \prod_{i \in I, j \notin I} \frac{\sinh \pi b (i \frac{Q}{2} - m_A + M_i - M_j)}{\sinh \pi b (M_i - M_j)} \prod_{i \in I} e^{ib \partial M_i}. \quad (4.12)$$

(the other is obtained by exchanging $b \rightarrow \frac{1}{b}$). Then,

$$\mathcal{H}_r(\vec{M}, m_A)\mathcal{Z}^T[N, m_A; \vec{M}, \vec{T}] = \chi_r(\vec{T})\mathcal{Z}^T[N, m_A; \vec{M}, \vec{T}] \quad (4.13)$$

where $r = 1, \dots, N$, and $\chi_r(\vec{T})$ are eigenvalues. Due to a peculiar property of the RS system, the same eigenfunction \mathcal{Z}^T satisfies also the so-called p - q dual equation:

$$\mathcal{H}_r(\vec{T}, -m_A)\mathcal{Z}^T[N, m_A; \vec{M}, \vec{T}] = \chi_r(\vec{M})\mathcal{Z}^T[N, m_A; \vec{M}, \vec{T}]. \quad (4.14)$$

Upon a redefinition of parameters, the two eigenvalue equations imply the identity:

$$\mathcal{Z}^T[N, m_A; \vec{M}, \vec{T}] = \mathcal{Z}^T[N, -m_A; \vec{T}, \vec{M}]. \quad (4.15)$$

The same steps can be repeated for the RS Hamiltonian in which $b \rightarrow \frac{1}{b}$, thus mirror symmetry is proven [11]. Quite interestingly, by considering the action of $K[\vec{M}, m_A]$ on the Hamiltonians ¹¹:

$$\mathcal{H}_r(\vec{M}, -m_A) = K[\vec{M}, m_A] \mathcal{H}_r(\vec{M}, m_A) K[\vec{M}, m_A]^{-1}, \quad (4.17)$$

we can also show from (4.14) that

$$\begin{aligned} \mathcal{H}_r(\vec{M}, -m_A) \mathcal{Z}^T[N, -m_A; \vec{M}, \vec{T}] &= \\ K[\vec{M}, m_A] \mathcal{H}_r(\vec{M}, m_A) K[\vec{M}, m_A]^{-1} \mathcal{Z}^T[N, -m_A; \vec{M}, \vec{T}] &= \\ &= \chi_r(\vec{T}) \mathcal{Z}^T[N, -m_A; \vec{M}, \vec{T}] \end{aligned} \quad (4.18)$$

Furthermore, using that $K[\vec{T}, m_A]$ commutes with $\mathcal{H}_r(\vec{M}, m_A)$ we find that the second and third terms in (4.18) provides the additional relation

$$\begin{aligned} \mathcal{H}_r(\vec{M}, m_A) \left(K[\vec{M}, -m_A] K[\vec{T}, m_A] \mathcal{Z}^T[N, -m_A; \vec{M}, \vec{T}] \right) \\ = \chi_r(\vec{T}) \left(K[\vec{M}, -m_A] K[\vec{T}, m_A] \mathcal{Z}^T[N, -m_A; \vec{M}, \vec{T}] \right). \end{aligned} \quad (4.19)$$

Therefore we conclude that $\mathcal{Z}^T[N, m_A; \vec{M}, \vec{T}]$ and $\mathcal{Z}^{FFT}[N, m_A; \vec{M}, \vec{T}]$ satisfy the same RS eigenvalue equation. Of course, the same argument can be used for the RS Hamiltonians in which $b \rightarrow 1/b$. Thus we conclude that $\mathcal{Z}^T[N, m_A; \vec{M}, \vec{T}] = \mathcal{Z}^{FFT}[N, m_A; \vec{M}, \vec{T}]$.

4.2 Sequential confinement: from $T[\text{SU}(N+1)]$ to Theory A

We now discuss the effect of the monopole deformation

$$\mathcal{L}_{\{1, \dots, N-1\}}^T = \mathcal{M}^{[10 \dots 00]} + \mathcal{M}^{[010 \dots 00]} + \dots + \mathcal{M}^{[00 \dots 10]}. \quad (4.20)$$

on the partition function of $T[\text{SU}(N+1)]$. First, let us observe that on each node where the monopole potential is turned on, the symmetry $U(1)_A \times U(1)_{\text{top}}$ is broken to the diagonal and consequently the FI parameters take special values related to the axial mass:

$$\xi^{(k)} = T_k - T_{k+1} = m_A + \frac{iQ}{2}, \quad k = 1, \dots, N-1. \quad (4.21)$$

The last node is underformed, so there is no constraint on $\xi^{(N)}$.

Following the logic of the sequential confinement, spelled out in section 3.1, we dualize the first gauge node, and sequentially all the nodes, by using the duality [15] between

$$U(k) \text{ with } k+1 \text{ flavors and } \mathcal{W} = \mathcal{M}^+ \quad \leftrightarrow \quad WZ \text{ model with } \mathcal{W} = \gamma \det M. \quad (4.22)$$

¹¹To see this we use the following property of the double sine function

$$s_b(m_A \pm x) e^{ib\partial_x} s_b(-m_A \pm x) = \frac{\sinh \pi b(m_A + x + i\frac{Q}{2})}{\sinh \pi b(-m_A + x + i\frac{Q}{2})}. \quad (4.16)$$

At the level of the partition functions this duality is obtained from the following evaluation formula:

$$\int dx^{(k)} e^{-\pi i(\eta-iQ)\sum_{j=1}^k x_j^{(k)}} Z_{\text{vec}}^{(k)} \tilde{Z}^{(k,k+1)}[\vec{M}, \vec{\mu}] \quad (4.23)$$

$$= (-)^k e^{-\pi i\sum_{a=1}^{k+1}(\eta-iQ+2\mu_a)M_a} s_b\left(\frac{iQ}{2}-\eta\right) \prod_{i,j=1}^{k+1} s_b\left(\frac{iQ}{2}-\mu_i-\mu_j-M_i+M_j\right)$$

with the definition

$$\tilde{Z}^{(N_c, N_f)}[\vec{M}, \vec{\mu}] = \prod_{i=1}^{N_c} \prod_{j=1}^{N_f} s_b\left(\frac{iQ}{2}-\mu_j \pm (x_i^{(N_c)} - M_j)\right) \quad (4.24)$$

and the constraint from the monopole superpotential

$$\eta = iQ - 2 \sum_{a=1}^{k+1} \mu_a. \quad (4.25)$$

We will actually need the identity (4.23) specialised to the case in which in the electric theory the fundamental chirals couple to the adjoint breaking the $SU(k+1) \times SU(k+1)$ global symmetry to the diagonal and consequently the parameters μ_a are specialised to $\mu_a = \frac{iQ}{4} + \frac{m_A}{2}$ for $a = 1, \dots, k+1$. The constraint now reads,

$$\eta = iQ - (k+1) \left(m_A + \frac{iQ}{2}\right) \quad (4.26)$$

and we find

$$\int dx^{(k)} e^{\pi i(k+1)(m_A+iQ/2)\sum_{j=1}^k x_j^{(k)}} Z_{\text{vec}}^{(k)} Z_{\text{bif}}^{(k,k+1)} \quad (4.27)$$

$$= (-)^k e^{\pi i k(m_A+iQ/2)\sum_{a=1}^{k+1} M_a} s_b\left(-\frac{iQ}{2} + (k+1)\left(m_A + \frac{iQ}{2}\right)\right) \left(Z_{\text{adj}}^{(k+1)}\right)^{-1}$$

where we identified $\prod_{a,b=1}^{k+1} s_b(-m_A + y_a - y_b) = (Z_{\text{adj}}^{(k+1)})^{-1}$. At this point, we can apply this identity to $\mathcal{Z}^T[N, m_A; \vec{M}, \vec{T}]$, with \vec{T} specialised as in eq. (4.21), starting from the first node, where the adjoint is a (gauge) singlet, and sequentially by promoting each time the real mass parameters to dynamical variables, i.e. $M_i \rightarrow x_i$. Consider the first few dualizations as a warm-up, we will highlight some crucial simplifications. Focusing on the integrands, the partition function reads

$$\int dx^{(1)} e^{2\pi i(m_A+iQ/2)x_1^{(1)}} s_b(m_A) Z_{\text{bif}}^{(1,2)}$$

$$\times \int dx^{(2)} e^{2\pi i(m_A+iQ/2)(x_1^{(2)}+x_2^{(2)})} Z_{\text{vec}}^{(2)} Z_{\text{adj}}^{(2)} Z_{\text{bif}}^{(2,3)} \dots \quad (4.28)$$

which becomes

$$\sim s_b(m_A) \int dx^{(2)} e^{3\pi i(m_A+iQ/2)(x_1^{(2)}+x_2^{(2)})} Z_{\text{vec}}^{(2)} Z_{\text{bif}}^{(2,3)}$$

$$\times \int dx^{(3)} e^{2\pi i(m_A+iQ/2)(x_1^{(3)}+x_2^{(3)}+x_3^{(3)})} Z_{\text{vec}}^{(3)} Z_{\text{adj}}^{(3)} Z_{\text{bif}}^{(3,4)} \dots \quad (4.29)$$

The effect of the confinement of the U(1) node has been to cancel the adjoint on the U(2) node and shift the FI. Both these modifications are such that we can apply (4.27) to the U(2) node. This procedure goes on sequentially.

After confining all nodes but the last one we obtain:

$$e^{+2\pi iT_{N+1} \sum_{i=1}^{N+1} M_i} \prod_{l=0}^{N-1} s_b \left(-\frac{iQ}{2} + (l+1) \left(m_A + \frac{iQ}{2} \right) \right) \times \int dx^{(N)} e^{2\pi i \left[\frac{N-1}{2} (m_A + iQ/2) + \xi^{(N)} \right] \sum_{j=1}^N x_j^{(N)}} Z_{\text{vec}}^{(N)} Z_{\text{bif}}^{(N,N+1)} \quad (4.30)$$

On the first line we recognize the contribution of the fields γ_l . Indeed, as explained around eq. (4.5), we can read out the R-charges by looking at the arguments of the s_b functions and we find: $(1 - R_{\gamma_l}) = -1 + (1 - \alpha)(l + 1)$, from which follows the solution $R_{\gamma_l} = 2 - 2(l + 1)r$. This is the same assignment of R-charges we read off from the superpotential $W_A = \sum_{m=1}^N \frac{(-1)^m}{m} \gamma_m \text{Tr}((\Pi^Q)^m)$, if we identify the indexes as $l + 1 = m$.

The partition function of theory A is finally obtained by making explicit the values of T_1, \dots, T_N , using the constraint $\sum_{i=1}^N T_i = 0$. Then

$$T_i = \frac{(N + 1) - 2i}{2} \left(m_A + \frac{iQ}{2} \right), \quad i = 1, \dots, N \quad (4.31)$$

and

$$T_{N+1} = T_N - \xi^{(N)} = -\frac{(N - 1)}{2} \left(m_A + \frac{iQ}{2} \right) - \xi^{(N)}. \quad (4.32)$$

The result is

$$\mathcal{Z}^A[N, m_A; \vec{M}, T_{N+1}] = e^{+2\pi iT_{N+1} \sum_{i=1}^{N+1} M_i} \prod_{l=0}^{N-1} s_b \left(-\frac{iQ}{2} + (l+1) \left(m_A + \frac{iQ}{2} \right) \right) \times \int dx^{(N)} e^{-2\pi iT_{N+1} \sum_{j=1}^N x_j^{(N)}} Z_{\text{vec}}^{(N)} Z_{\text{bif}}^{(N,N+1)}. \quad (4.33)$$

4.3 Nilpotent mass deformation: from $T[\text{SU}(N + 1)]^\vee$ to Theory B

In $T[\text{SU}(N + 1)]^\vee$ the parameters T_i become real masses for the flavor symmetry and m_A changes sign, according to mirror symmetry. The identity between partition functions is indeed

$$\mathcal{Z}^T[N, m_A; \vec{M}, \vec{T}] = \mathcal{Z}^T[N, -m_A; \vec{T}, \vec{M}] \equiv \mathcal{Z}^{T^\vee}[N, m_A; \vec{M}, \vec{T}] \quad (4.34)$$

The new FI parameters entering the mirror partition function are $\zeta^{(a)} = M_a - M_{a+1}$. The values of the T_i we fixed in (4.31) lead to a telescopic cancellation of the one-loop

contributions of $N - 1$ flavors. In more details,

$$\begin{aligned}
 & \prod_{i=1}^N \prod_{j=1}^{N+1} s_b \left(\frac{iQ}{4} + \frac{m_A}{2} \pm (x_i^{(N)} - T_j) \right) \\
 &= \prod_{i=1}^N s_b \left(\frac{iQ}{4} + \frac{m_A}{2} \pm (x_i^{(N)} - T_{N+1}) \right) \\
 & \quad \times \prod_{j=1}^N s_b \left(\frac{iQ}{4} + \frac{m_A}{2} \pm \left(x_i^{(N)} - \frac{(N+1) - 2j}{2} \left(m_A + \frac{iQ}{2} \right) \right) \right) \quad (4.35) \\
 &= \prod_{i=1}^N s_b \left(\frac{iQ}{4} + \frac{m_A}{2} \pm (x_i^{(N)} - T_{N+1}) \right) \frac{s_b \left(x_i^{(N)} + \frac{N}{2} \left(m_A + \frac{iQ}{2} \right) \right)}{s_b \left(x_i^{(N)} - \frac{N}{2} \left(m_A + \frac{iQ}{2} \right) \right)}
 \end{aligned}$$

where we highlighted the cancellations in the last line. The partition function of theory B is then

$$\begin{aligned}
 \mathcal{Z}^B[N, m_A; \vec{M}, T_{N+1}] &= e^{2\pi i M_{N+1} T_{N+1}} \int \prod_{k=1}^{N-1} dx^{(k)} e^{2\pi i \zeta^{(k)} \sum_{a=1}^k x_a^{(k)}} Z_{\text{vec}}^{(k)} Z_{\text{adj}}^{(k)} Z_{\text{bif}}^{(k, k+1)} \\
 & \quad \times \int dx^{(N)} e^{2\pi i \zeta^{(N)} \sum_{a=1}^N x_a^{(N)}} Z_{\text{vec}}^{(N)} Z_{\text{adj}}^{(N)} \tilde{Z}^{(N,1)} \left[T_{N+1}, \frac{iQ}{4} - \frac{m_A}{2} \right] Z^d \quad (4.36)
 \end{aligned}$$

where we used $\sum_{i=1}^N T_i = 0$ in the prefactor, and defined

$$Z^d = \prod_{i=1}^N s_b \left(\frac{N}{2} \left(m_A + \frac{iQ}{2} \right) \pm x_i^{(N)} \right) \quad (4.37)$$

The contributions Z^d corresponds to the fundamentals fields d and \tilde{d} . Looking at the coefficient of $\frac{iQ}{2}$ we see that $1 - R_d = \frac{N}{2}(1 - \alpha)$ so $R_d = 1 - Nr$ as expected. The contribution $\tilde{Z}^{(N,1)}$ originates from two fundamentals chirals with R-charge $(1 - r)$, which are still part of the tail in the quiver diagram.

4.4 Partition functions on the A-to-D side

We obtain theory D from theory A by applying Aharony duality. As reviewed in appendix B, Aharony duality is implemented by the following integral identity,

$$\begin{aligned}
 & \int dx^{(N_c)} e^{-\pi i \lambda \sum_j x_j^{(N_c)}} Z_{\text{vec}}^{(N_c)} \tilde{Z}^{(N_c, N_f)}[\vec{M}, \vec{\mu}] \\
 &= e^{-i\pi \lambda \sum_{a=1}^{N_f} M_a} s_b \left(\frac{iQ}{2} (N_c - N_f) + |\vec{\mu}| \pm \frac{\lambda}{2} \right) \\
 & \quad \times \prod_{a,b=1}^{N_f} s_b \left(\frac{iQ}{2} - \mu_a - \mu_b - M_a + M_b \right) \quad (4.38) \\
 & \quad \times \int dx^{(N_f - N_c)} e^{-\pi i \lambda \sum_j x_j^{(N_f - N_c)}} Z_{\text{vec}}^{(N_f - N_c)} \tilde{Z}^{(N_f - N_c, N_f)} \left[-\vec{M}, \frac{iQ}{2} - \vec{\mu} \right]
 \end{aligned}$$

with $\tilde{Z}^{(N_c, N_f)}$ defined in (4.24). Notice that here we have a background Chern-Simon term (the exponential prefactor in the second line) coupling the topological and the flavor symmetry.

For $N_c = N$, $N_f = N + 1$ and $\lambda = 2T_{N+1}$, the l.h.s. of (4.38) coincides with the integrand of \mathcal{Z}^A . However, since theory A has a non trivial superpotential, which breaks $SU(N_f) \times SU(N_f)$ to $SU(N_f) \times U(1)_A$, we need to consider the identification $\mu_a = \frac{iQ}{4} + \frac{m_A}{2}$ for $a = 1, \dots, N_f$. Finally, we obtain \mathcal{Z}^D upon including the prefactor associated to the dual of the fields $\gamma_{l \geq 0}$ of theory A . We find:

$$\begin{aligned}
 \mathcal{Z}^D[N, m_A; \vec{M}, T_{N+1}] &= s_b \left(-\frac{iQ}{2} + \frac{N+1}{2} \left(m_A + \frac{iQ}{2} \right) \pm \xi \right) \prod_{a,b=1}^{N+1} s_b(-m_A + M_a - M_b) \\
 &\times \prod_{l=0}^{N-1} s_b \left(-\frac{iQ}{2} + (l+1) \left(m_A + \frac{iQ}{2} \right) \right) \\
 &\times \int dx e^{-2\pi i T_{N+1} x} \tilde{Z}^{(1, N+1)} \left[-\vec{M}, \frac{iQ}{4} - \frac{m_A}{2} \right]
 \end{aligned} \tag{4.39}$$

Some comments on \mathcal{Z}^D are in order. There is a cancellation of contact terms when using (4.38) on the integrand of theory A . This is so because the FI of theory A , compared to $T[SU(N+1)]$, has been reduced to T_{N+1} during the sequential confinement.

In the notation of section 3.4, we recognize in the first line of \mathcal{Z}^D the contribution of the two singlets, σ_{\pm} , and that of $(N+1)^2$ singlets $F_D^{\mathcal{U}}$. The fields σ_{\pm} are flipping fields for the monopoles, and the fields $F_D^{\mathcal{U}}$ flip the meson. From the arguments of the s_b we read out $(1 - R_{\sigma_{\pm}}) = -1 + \frac{N+1}{2}(1 - \alpha)$, or $R_{\sigma_{\pm}} = 2 - (N+1)r$. We then find that $(1 - R_{F_D^{\mathcal{U}}}) = \alpha$, or $R_{F_D^{\mathcal{U}}} = 1 - \alpha = 2r$. Notice also that the contribution of θ_1 (the coefficient with $l = 0$ in the product) cancels the diagonal contributions of the singlets $F_D^{\mathcal{U}}$, effectively enforcing the tracelessness of $F_D^{\mathcal{U}}$.

4.5 $T[SU(2)]$

The case of $T[SU(2)]$ is simple enough to compute the partition function explicitly. In this case, our monopole deformation is empty, thus the partition function of theory A is directly that of $T[SU(2)]$, with the specification $T_1 = 0$. The presence of flipping fields, and the non trivial mapping of parameters across the commutative diagram, makes the equalities of partition functions a nice exercise to go through. In these computations we will keep $M_1 \neq M_2$.

The integrand of the $T[SU(2)]$ partition function can be quickly evaluated by residue integration [41]. The full partition function will also include a factor of $Z_{adj}^{(1)} = s_b(m_A)$, and an exponential prefactor. In our conventions, $\xi = T_1 - T_2$,

$$\mathcal{Z}^T[1, m_A, \vec{M}, \vec{T}] = e^{2\pi i T_2 (M_1 + M_2)} s_b(m_A) \int_{-\infty}^{+\infty} dx e^{2\pi i x \xi} \prod_{i=1}^2 \frac{s_b(+\frac{iQ}{4} - \frac{m_A}{2} + (x - M_i))}{s_b(-\frac{iQ}{4} + \frac{m_A}{2} + (x - M_i))} \tag{4.40}$$

We pick poles of the two s_b functions at the numerator, and assign to the set of poles labelled by M_i , the series \mathcal{S}_i defined as,

$$\begin{aligned} \mathcal{S}_i &= e^{2\pi i \xi M_i} e^{i\pi \xi (iQ/2 + m_A)} \frac{s_b\left(\frac{iQ}{2} + (-)^i (M_2 - M_1)\right)}{s_b(m_A) s_b(m_A + (-)^i (M_2 - M_1))} \\ &\times {}_2\varphi_1^{(q)} \left[q^{\frac{1}{2}} e^{2\pi b m_A}, q^{\frac{1}{2}} e^{2\pi b ((-)^i (M_2 - M_1) + m_A)}; q e^{(-)^i 2\pi b (M_2 - M_1)}; q^{\frac{1}{2}} e^{-2\pi b (\xi + m_A)} \right] \\ &\times {}_2\varphi_1^{(\tilde{q})} \left[\tilde{q}^{\frac{1}{2}} e^{\frac{2\pi}{b} m_A}, \tilde{q}^{\frac{1}{2}} e^{\frac{2\pi}{b} ((-)^i (M_2 - M_1) + m_A)}; \tilde{q} e^{(-)^i \frac{2\pi}{b} (M_2 - M_1)}; \tilde{q}^{\frac{1}{2}} e^{-\frac{2\pi}{b} (\xi + m_A)} \right] \end{aligned} \quad (4.41)$$

Recall the definitions $q = e^{2\pi i b Q}$ and $\tilde{q} = e^{2\pi i Q/b}$. The hypergeometric function ${}_2\varphi_1^{(q)}$ admits the series representation

$${}_2\varphi_1^{(q)} [a, b; c; z] = \sum_n \frac{(a; q)_n (b; q)_n}{(q; q)_n (c; q)_n} z^n, \quad |q| < 1. \quad (4.42)$$

If $|q| < 1$ and $|\tilde{q}| > 1$ we use the relation

$${}_2\varphi_1^{(\tilde{q})} [a, b; c; z] = {}_2\varphi_1^{(1/\tilde{q})} [a^{-1}, b^{-1}; c^{-1}; abz/(\tilde{q}c)], \quad (4.43)$$

where the r.h.s. can be expanded out as in (4.42). The partition function is invariant under $b \leftrightarrow 1/b$ and can be written as the sum $\sum_{i=1}^2 e^{2\pi i T_2 (M_1 + M_2)} s_b(m_A) \mathcal{S}_i$. We will work with its factorized expression [45], namely

$$\mathcal{Z}^T [1, m_A, \vec{M}, \vec{T}] = e^{2\pi i \mathcal{P}} \left[\mathcal{B}_1^{(\tilde{q})}, \mathcal{B}_2^{(\tilde{q})} \right] \begin{bmatrix} 1 & 0 \\ 0 & e^{2\pi i (M_2 - M_1) (\xi + m_A - iQ/2)} \end{bmatrix} \begin{bmatrix} \mathcal{B}_1^{(q)} \\ \mathcal{B}_2^{(q)} \end{bmatrix} \quad (4.44)$$

In (4.44) we isolated the following exponential prefactor

$$\begin{aligned} \mathcal{P} &= (T_1 M_1 + T_2 M_2) + \frac{(T_1 - T_2)(m_A + iQ/2) + (M_1 - M_2)(m_A - iQ/2)}{2} \\ &\quad + \frac{(m_A^2 + Q^2/4)}{4} \end{aligned} \quad (4.45)$$

and defined the holomorphic blocks $\mathcal{B}_{i=1,2}$ associated to the series $\mathcal{S}_{i=1,2}$.¹²

$$\mathcal{B}_2^{(q)} [\vec{M}, \vec{T}] = \mathcal{B}_1^{(q)} [-\vec{M}, \vec{T}], \quad (4.46)$$

$$\begin{aligned} \mathcal{B}_1^{(q)} [\vec{M}, \vec{T}] &= \frac{(q e^{2\pi b (M_1 - M_2)}, q)_\infty}{(q^{\frac{1}{2}} e^{2\pi b (M_1 - M_2 + m_A)}, q)_\infty} \\ &\quad \times {}_2\varphi_1^{(q)} \left[q^{\frac{1}{2}} e^{2\pi b m_A}, q^{\frac{1}{2}} e^{2\pi b (M_1 - M_2 + m_A)}; q e^{2\pi b (M_1 - M_2)}, q^{\frac{1}{2}} e^{2\pi b (T_2 - T_1 - m_A)} \right] \end{aligned} \quad (4.47)$$

The holomorphic blocks of theory A , $\mathcal{B}_{i=1,2}^A$, can be defined from $\mathcal{B}_{i=1,2}$ by setting $T_1 = 0$. Whenever needed we will understand $b \rightarrow b^{-1}$ in the conjugate blocks $\mathcal{B}_{i=1,2}^{(\tilde{q})}$.

¹²Compared to [45] we do not introduce Θ -functions to factorize exponential terms, but we use the ‘factorization’ matrix (4.44).

Aharony duality. The partition function of theory D is given by (4.39),

$$\begin{aligned} \mathcal{Z}^D[1, m_A; \vec{M}, -\xi] &= s_b(m_A \pm \xi) \prod_{a,b=1}^2 s_b(-m_A + M_a - M_b) \\ &\times s_b(m_A) \int_{-\infty}^{+\infty} dx e^{2\pi i x \xi} \prod_{i=1}^2 \frac{s_b(+\frac{iQ}{4} + \frac{m_A}{2} + (x + M_i))}{s_b(-\frac{iQ}{4} - \frac{m_A}{2} + (x + M_i))} \end{aligned} \quad (4.48)$$

The FI parameter ξ should be fixed to be $-T_2$, but we are keeping it generic for comparison with Z^{FFT} in the next section. The integrand (4.48) can be evaluated by residue integration, as in (4.41). The modifications are minors so we will not repeat them. Instead, after writing the partition function in the factorized form, we show how the blocks map into each other when going from theory A to theory D . The factorization of the partition function is

$$\mathcal{Z}^D[1, m_A; \vec{M}, -\xi] = e^{2\pi i \mathcal{P}} \left[\mathcal{B}_1^{D(\tilde{q})}, \mathcal{B}_2^{D(\tilde{q})} \right] \begin{bmatrix} e^{2\pi i (M_2 - M_1)(\xi + m_A - iQ/2)} & 0 \\ 0 & 1 \end{bmatrix} \begin{bmatrix} \mathcal{B}_1^{D(q)} \\ \mathcal{B}_2^{D(q)} \end{bmatrix} \quad (4.49)$$

where \mathcal{P} is the same prefactor (4.45) and the holomorphic blocks are

$$\mathcal{B}_2^{D(q)}[\vec{M}, \vec{T}] = \mathcal{B}_1^{D(q)}[-\vec{M}, \vec{T}], \quad (4.50)$$

$$\begin{aligned} \mathcal{B}_1^{D(q)}[\vec{M}, \vec{T}] &= \frac{(qe^{-2\pi b(M_1 - M_2)}, q)_\infty (q^{\frac{1}{2}} e^{-2\pi b(\xi - m_A)}, q)_\infty}{(q^{\frac{1}{2}} e^{-2\pi b(M_1 - M_2 - m_A)}, q)_\infty (q^{\frac{1}{2}} e^{-2\pi b(\xi + m_A)}, q)_\infty} \\ &\times {}_2\varphi_1^{(q)} \left[q^{\frac{1}{2}} e^{-2\pi b m_A}, q^{\frac{1}{2}} e^{2\pi b(M_2 - M_1 - m_A)}; qe^{2\pi b(M_2 - M_1)}, q^{\frac{1}{2}} e^{2\pi b(-\xi + m_A)} \right] \end{aligned} \quad (4.51)$$

By using the second of the Heine's identities [44],

$${}_2\varphi_1^{(q)}[a, b; c; z] = \frac{(abz/c)_\infty}{(z)_\infty} {}_2\varphi_1^{(q)}[c/a, c/b; c; abz/c] \quad (4.52)$$

and its \tilde{q} analog, which in this case coincides with (4.52), we find

$$\begin{bmatrix} \mathcal{B}_1^{D(q)} \\ \mathcal{B}_2^{D(q)} \end{bmatrix} = \begin{bmatrix} 0 & 1 \\ 1 & 0 \end{bmatrix} \begin{bmatrix} \mathcal{B}_1^{A(q)} \\ \mathcal{B}_2^{A(q)} \end{bmatrix} \quad (4.53)$$

Thus, we have shown the equality

$$\mathcal{Z}^D[1, m_A; \vec{M}, T_2] = \mathcal{Z}^A[1, m_A; \vec{M}, T_2]. \quad (4.54)$$

Flip-Flip duality. In order to compute Z^{FFT} we follow our prescription (4.8). Considering $Z^T[1, -m_A; \dots]$, with Z^T given in (4.40), we obtain

$$\begin{aligned} \mathcal{Z}^{FFT}[1, m_A, \vec{M}, \vec{T}] &= K[\vec{M}, -m_A] K[\vec{T}, m_A] s_b(-m_A) \\ &\times e^{2\pi i T_2(M_1 + M_2)} \int_{-\infty}^{+\infty} dx e^{2\pi i x \xi} \prod_{i=1}^2 \frac{s_b(+\frac{iQ}{4} + \frac{m_A}{2} + (x - M_i))}{s_b(-\frac{iQ}{4} - \frac{m_A}{2} + (x - M_i))} \end{aligned} \quad (4.55)$$

Recall that $K[\vec{x}, m_A] = \prod_{i,j} s_b(m_A \pm (x_i - x_j))$, therefore

$$\begin{aligned} \mathcal{Z}^{FFT}[1, m_A, \vec{M}, \vec{T}] &= s_b(m_A \pm \xi) s_b(-m_A \pm (M_1 - M_2)) s_b(-m_A) \\ &\times e^{2\pi i T_2 (M_1 + M_2)} \int_{-\infty}^{+\infty} dx e^{2\pi i x \xi} \prod_{i=1}^2 \frac{s_b(+\frac{iQ}{4} + \frac{m_A}{2} + (x - M_i))}{s_b(-\frac{iQ}{4} - \frac{m_A}{2} + (x - M_i))} \end{aligned} \quad (4.56)$$

Very similarly to the $TSU(2)$ computation, we evaluate the integrand in (4.56) and factorize the result into

$$\mathcal{Z}^{FFT}[1, m_A, \vec{M}, \vec{T}] = e^{2\pi i \mathcal{P}} \left[\mathcal{B}_1^{FF(\tilde{q})}, \mathcal{B}_2^{FF(\tilde{q})} \right] \begin{bmatrix} 1 & 0 \\ 0 & e^{2\pi i (M_2 - M_1)(\xi + m_A - iQ/2)} \end{bmatrix} \begin{bmatrix} \mathcal{B}_1^{FFT(q)} \\ \mathcal{B}_2^{FFT(q)} \end{bmatrix}$$

where, by using again (4.52) on the holomorphic blocks $\mathcal{B}_{i=1,2}^{FF}$, we find

$$\begin{bmatrix} \mathcal{B}_1^{FF(q)} \\ \mathcal{B}_2^{FF(q)} \end{bmatrix} = \begin{bmatrix} 1 & 0 \\ 0 & 1 \end{bmatrix} \begin{bmatrix} \mathcal{B}_1^{(q)} \\ \mathcal{B}_2^{(q)} \end{bmatrix} \quad (4.57)$$

Thus we have shown that

$$\mathcal{Z}^{FFT}[1, m_A, \vec{M}, \vec{T}] = \mathcal{Z}^T[1, m_A, \vec{M}, \vec{T}] \quad (4.58)$$

Notice that our definition of \mathcal{Z}^{FFT} in (4.8), which was strongly motivated by the use of difference operators, has correctly captured possible field theory contact terms.

In section 2.2 we used a field theory argument to show that Aharony duality applied to $T[\text{SU}(2)]$ is related to Flip-Flip duality. This is consistent with the observation that (4.58) and (4.54) follow from the same Heine's identity (4.52), i.e. they are not independent. However, we did not obtain Flip-Flip duality directly, and we insisted on some additional manipulations. These manipulations will also be visible at the level of the partition function: consider the action of Aharony duality on $T[\text{SU}(2)]$ by implementing (4.38) on the integrand of Z^T . We denote this by $\mathcal{A} \circ Z^T$. Then, we find the relation

$$\mathcal{Z}^{FFT}[1, m_A, -\vec{M}, \vec{T}] = e^{-2\pi T_1 (M_1 + M_2)} \mathcal{A} \circ Z^T[1, m_A, \vec{M}, \vec{T}] \quad (4.59)$$

The contribution of the $\text{SU}(2)_{\text{flavor}} \times \text{SU}(2)_{\text{top}}$ flipping fields in $FFT[\text{SU}(2)]$ comes out as follows: on the r.h.s. of (4.59) we find

$$s_b(m_A) \times \left[s_b(\pm \xi + m_A) \prod_{a,b=1}^2 s_b(-m_A + M_a - M_b) \right] \quad (4.60)$$

where the terms in parenthesis [...] are introduced by the Aharony duality. Then, one of the diagonal contributions, i.e. $a = b = 1$ or $a = b = 2$, simplifies with the original $s_b(m_A)$ of $T[\text{SU}(2)]$, and we recover the same prefactors as in (4.56). Furthermore, when the constraint $M_1 + M_2 = 0$ is imposed, the relation (4.59) implies the equalities

$$\mathcal{Z}^{FFT}[1, m_A] = \mathcal{A} \circ Z^T[1, m_A] = \mathcal{Z}^D[1, m_A; T_2 - T_1], \quad (4.61)$$

as expected from the field theory argument.

Mirror symmetry. Explicit computations about the partition functions of $T[\text{SU}(2)]$ and $T[\text{SU}(2)]^\vee$ have been done in [45]. For sake of completeness, we repeat them in our notation to show consistency. We shall refer directly to theory A and theory B , since the monopole deformation is empty.

We write $\zeta = M_1 - M_2$ and

$$\mathcal{Z}^{T^\vee}[1, m_A; \vec{M}, \vec{T}] = e^{+2\pi i M_2(T_1+T_2)} s_b(-m_A) \int_{-\infty}^{+\infty} dx e^{-2\pi i \zeta x} \prod_{i=1}^2 \frac{s_b(\frac{iQ}{4} + \frac{m_A}{2} + (x + T_i))}{s_b(-\frac{iQ}{4} - \frac{m_A}{2} + (x + T_i))} \quad (4.62)$$

Notice the change of variables $x \rightarrow -x$ compared to (4.34). In its factorized form we can then extract the same prefactor \mathcal{P} , given in (4.45), and obtain,

$$\mathcal{Z}^{T^\vee}[1, m_A; \vec{M}, \vec{T}] = e^{2\pi i \mathcal{P}} \left[\mathcal{B}_1^{B(\tilde{q})}, \mathcal{B}_2^{B(\tilde{q})} \right] \begin{bmatrix} 1 & 0 \\ 0 & e^{2\pi i(M_2 - M_1)\xi} e^{-i\pi(m_A^2 + Q^2/4)} \end{bmatrix} \begin{bmatrix} \mathcal{B}_1^{B(q)} \\ \mathcal{B}_2^{B(q)} \end{bmatrix} \quad (4.63)$$

where the blocks are

$$\mathcal{B}_1^{B(q)}[\vec{M}, \vec{T}] = \frac{(q e^{-2\pi b(T_1 - T_2)}, q)_\infty}{(q^{\frac{1}{2}} e^{-2\pi b(T_1 - T_2 + m_A)}, q)_\infty} \times {}_2\varphi_1^{(q)} \left[q^{\frac{1}{2}} e^{-2\pi b m_A}, q^{\frac{1}{2}} e^{2\pi b(T_2 - T_1 - m_A)}; q e^{2\pi b(T_2 - T_1)}, q^{\frac{1}{2}} e^{2\pi b(M_1 - M_2 + m_A)} \right] \quad (4.64)$$

$$\mathcal{B}_2^{B(q)}[\vec{M}, \vec{T}] = \frac{(e^{-2\pi b(T_1 - T_2)}, q)_\infty^{-1}}{(q^{\frac{1}{2}} e^{-2\pi b(T_1 - T_2 - m_A)}, q)_\infty^{-1}} \times {}_2\varphi_1^{(q)} \left[q^{\frac{1}{2}} e^{-2\pi b m_A}, q^{\frac{1}{2}} e^{2\pi b(T_1 - T_2 - m_A)}; q e^{2\pi b(T_1 - T_2)}, q^{\frac{1}{2}} e^{2\pi b(M_1 - M_2 + m_A)} \right] \quad (4.65)$$

The map between blocks under mirror symmetry is more involved than (4.53). It can be derived from the use of the first Heine's identity

$${}_2\varphi_1^{(q)}[a, b; c; z] = \frac{(b)_\infty (az)_\infty}{(c)_\infty (z)_\infty} {}_2\varphi_1^{(q)}[c/b, z, az; b] \quad (4.66)$$

and the analytic continuation formulas [45]. The result is

$$\begin{bmatrix} \mathcal{B}_1^{B(q)} \\ \mathcal{B}_2^{B(q)} \end{bmatrix} = \begin{bmatrix} 1 & 0 \\ c_{21}^{(q)} & c_{22}^{(q)} \end{bmatrix} \begin{bmatrix} \mathcal{B}_1^{A(q)} \\ \mathcal{B}_2^{A(q)} \end{bmatrix} \quad (4.67)$$

with

$$c_{22}^{(q)} = \frac{(q^{\frac{1}{2}} e^{2\pi b(M_1 - M_2 - m_A)}, q)_\infty (q^{\frac{1}{2}} e^{-2\pi b(M_1 - M_2 - m_A)}, q)_\infty}{(e^{2\pi b(M_1 - M_2)}, q)_\infty (q e^{-2\pi b(M_1 - M_2)}, q)_\infty} \quad (4.68)$$

$$c_{21}^{(q)} = \frac{e^{-2\pi b(T_1 - T_2)} (e^{2\pi b(T_1 - T_2 + M_1 - M_2)}, q)_\infty (q e^{-2\pi b(T_1 - T_2 + M_1 - M_2)}, q)_\infty (q^{\frac{1}{2}} e^{\pm 2\pi b m_A}, q)_\infty}{(e^{-2\pi b(T_1 - T_2)}, q)_\infty (q e^{2\pi b(T_1 - T_2)}, q)_\infty (e^{2\pi b(M_1 - M_2)}, q)_\infty (q e^{-2\pi b(M_1 - M_2)}, q)_\infty} \quad (4.69)$$

For the conjugate blocks we get

$$\begin{bmatrix} \mathcal{B}_1^{B(\tilde{q})} \\ \mathcal{B}_2^{B(\tilde{q})} \end{bmatrix} = \begin{bmatrix} 1 & -c_{22}^{(\tilde{q})}/c_{21}^{(\tilde{q})} \\ 0 & c_{22}^{(\tilde{q})} \end{bmatrix} \begin{bmatrix} \mathcal{B}_1^{A(\tilde{q})} \\ \mathcal{B}_2^{A(\tilde{q})} \end{bmatrix} \quad (4.70)$$

The connection matrix in (4.70) is essentially the inverse of (4.67), transposed.

5 Spectral dualities

In this section we connect the dualities discussed in the first part of the paper to a class of $3d$ dualities which we call spectral dualities since they have their origin in $5d$ spectral dualities, or fiber-base duality in topological string.

In the introduction we claimed that $3d$ spectral dual pairs can be regarded as $3d \mathcal{N} = 2$ theories living on a codimension-two defect which is coupled to a (trivial) $5d \mathcal{N} = 1$ theory. The starting point of this construction is a toric CY three-fold \mathfrak{X} which engineers a $5d \mathcal{N} = 1$ linear quiver theory. A $3d - 5d$ coupled system can be obtained via Higgsing, by tuning the Kähler parameters of the CY \mathfrak{X} in a specific way. The resulting CY will be denoted by \mathcal{X}^{13} and since we will be considering a *complete* Higgsing it will correspond to the $3d$ theory $\mathcal{T}_{\mathcal{X}}$ coupled to $5d$ free hypermultiplets. In particular the topological string partition function we started with reduces to the partition function of our $3d$ theory $\mathcal{T}_{\mathcal{X}}$. From the original fiber-base duality of the CY, we can then infer the existence of $3d$ dualities, which we will discuss in the next section.

More precisely, we have found the following relation between the holomorphic block ($D^2 \times S^1$ partition function) $\mathcal{B}_{\mathcal{T}_{\mathcal{X}}}^{\alpha_0}$ evaluated on a contour α_0 and the partition function of the Higgsed topological string on \mathcal{X} :

$$\mathcal{B}_{\mathcal{T}_{\mathcal{X}}}^{\alpha_0} = \mathcal{E}_{\mathcal{T}_{\mathcal{X}}} Z_{\text{cl}, \mathcal{T}_{\mathcal{X}}}^{\alpha_0} Z_{1\text{-loop}, \mathcal{T}_{\mathcal{X}}}^{\alpha_0} Z_{\text{vort}, \mathcal{T}_{\mathcal{X}}}^{\alpha_0} = G Z_{1\text{-loop}, \text{top}}^{\mathcal{X}} Z_{\text{vort}, \text{top}}^{\mathcal{X}}. \quad (5.1)$$

We have separated the topological string partition function on the r.h.s. of eq. (5.1) into two pieces, $Z_{1\text{-loop}, \text{top}}^{\mathcal{X}}$ and $Z_{\text{vort}, \text{top}}^{\mathcal{X}}$ which coincide with the vortex part of the $3d$ partition function. $Z_{1\text{-loop}, \text{top}}^{\mathcal{X}}$ is independent of the $3d$ FI parameters, and hence of the corresponding Kähler parameters of the CY, while $Z_{\text{vort}, \text{top}}^{\mathcal{X}}$ does depend on them. Finally G denotes a possible fiber-base invariant prefactor and $\mathcal{E}_{\mathcal{T}}$ a contact term.

The choice of contour α_0 on which the holomorphic block is evaluated corresponds to a particular way of tuning the Kähler parameters to implement the Higgsing. More concretely, the different contours correspond to Higgsed toric CY's, in which the spectral parameters in the *external* legs of the toric diagram are fixed, while the internal ones can vary. For example, two Higgsed CY's corresponding to two contours (or vacua) of the $FT[\text{SU}(2)]$ theory are shown in figure 1 (see section 5.3 for notations).

In the following we present our two main spectral dual pairs:

- 1) $FT[\text{SU}(N + 1)] \leftrightarrow FT[\text{SU}(N + 1)]^{\vee}$, which is obtained from the $T[\text{SU}(N + 1)]$ commutative diagram, upon flipping the edge $FFT[\text{SU}(N + 1)] \leftrightarrow T[\text{SU}(N + 1)]^{\vee}$.
- 2) $\mathcal{T} \leftrightarrow \mathcal{T}'$, which is obtained from the $D \leftrightarrow B$ duality in the $ABCD$ framework.

After discussing the field theory evidence of these dualities we will see how the holomorphic blocks of each theory can be obtained via Higgsing from a topological string partition function and we will then explicitly see how the spectral duality descends from the fiber-base duality.

¹³We denote by \mathfrak{X} or \mathcal{X} the toric graphs together with the values of complexified Kähler parameters of the corresponding CY manifold. In particular \mathfrak{X} has generic Kähler parameters whereas in \mathcal{X} they are tuned to special quantised values.

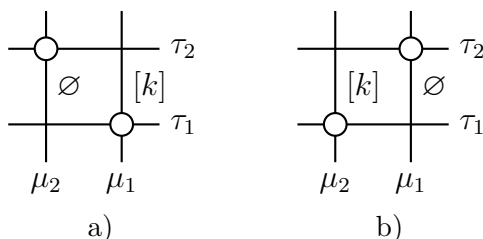

Figure 1. Two toric CY diagrams corresponding to two vacua of the 3d $FT[\text{SU}(2)]$ theory. Notice that the spectral parameters of external legs are the same in both cases.

5.1 $FT[\text{SU}(N + 1)]$ and its spectral dual

Our starting point is the duality $FFT[\text{SU}(N + 1)] \leftrightarrow T[\text{SU}(N + 1)]^\vee$, on the SW-NE diagonal of the diagram 2.30. Recall that $FFT[\text{SU}(N + 1)]$ has two sets of singlets $F_{ij}^{\mathcal{R}}$ and $F_{ij}^{\mathcal{m}}$ which flip the HB and CB moment maps:

$$\mathcal{W}_{FFT[\text{SU}(N+1)]} = W^T[\Theta, \mathbb{R}] + \Pi_{ij}^{\mathcal{R}} F_{ij}^{\mathcal{R}} + m_{ij} F_{ij}^{\mathcal{m}}. \quad (5.2)$$

We now add another set of $(N + 1)^2$ singlets F_{ij}^T and deform the $FFT[\text{SU}(N + 1)]$ theory by the superpotential $\delta\mathcal{W} = F_{ij}^T F_{ij}^{\mathcal{m}}$. We are basically flipping twice the Coulomb branch of $T[\text{SU}(N + 1)]$ and since $\text{flip}^2 = 1$, as it is easy to see by using the equations of motion, we find a new theory, which we call $FT[\text{SU}(N + 1)]$, where only the Higgs branch moment map is flipped:

$$\mathcal{W}_{FT[\text{SU}(N+1)]} = W^T[\Theta, \mathbb{R}] + \Pi_{ij}^{\mathcal{R}} F_{ij}^{\mathcal{R}}. \quad (5.3)$$

On the dual side $FT[\text{SU}(N + 1)]^\vee$, we proceed similarly. We add new $(N + 1)^2$ singlets which we call $F_{ij}^{\mathcal{P}}$, and the superpotential deformation $\delta\mathcal{W} = F_{ij}^{\mathcal{P}} \Pi_{ij}^{\mathcal{P}}$. This deformation is dual to that for $FT[\text{SU}(N + 1)]$, since in the commutative diagram the singlets $F_{ij}^{\mathcal{m}}$ are mapped into the mesons moment map $\Pi_{ij}^{\mathcal{P}}$. The resulting $FT[\text{SU}(N + 1)]^\vee$ theory has

$$\mathcal{W}_{FT[\text{SU}(N+1)]^\vee} = W^T[\Omega, \mathbb{P}] + \Pi_{ij}^{\mathcal{P}} F_{ij}^{\mathcal{P}}. \quad (5.4)$$

If we assign R -charge r to the quarks, on the side of $FT[\text{SU}(N + 1)]$ we find a monopole matrix with $R[m_{ij}] = 2 - 2r$ on the CB, and $R[F_{ij}^{\mathcal{R}}] = 2 - 2r$. On the side of $FT[\text{SU}(N + 1)]^\vee$ we again assign R -charge r to the quarks so that again we will find a monopole matrix with $R[\mathcal{N}_{ij}] = 2 - 2r$, and $R[F_{ij}^{\mathcal{P}}] = 2 - 2r$. The operator map will be:

$$F_{ij}^{\mathcal{R}} \leftrightarrow \mathcal{N}_{ij}, \quad m_{ij} \leftrightarrow F_{ij}^{\mathcal{P}}. \quad (5.5)$$

The first evidence of this duality was obtained in [25] using difference operators acting on the holomorphic blocks. The argument is similar to our discussion in section 4.1.

The partition function of the $FT[\text{SU}(N + 1)]$ theory is simply obtained by multiplying the partition function of $T[\text{SU}(N + 1)]$ by the contribution of the flipping singlets which transform in the adjoint of the $\text{SU}(N + 1)$ flavor symmetry:

$$\mathcal{Z}^{FT}[N, m_A; \vec{M}, \vec{T}] \equiv K'[\vec{M}, m_A] \mathcal{Z}^T[N, m_A; \vec{M}, \vec{T}], \quad (5.6)$$

where the prime indicates that we removed the trace part from the singlet contribution.

Considering the map of operators in (5.5) we see that flavor and topological fugacities will be swapped in the partition function of the dual theory, but the sign of m_A will not change, consistently with our R-charge assignment. We have:

$$\mathcal{Z}^{FT^\vee}[N, m_A; \vec{M}, \vec{T}] \equiv \mathcal{Z}^{FT}[N, m_A; \vec{T}, \vec{M}]. \quad (5.7)$$

Proving our spectral duality at the level of partition functions requires to prove the following identity:

$$\mathcal{Z}^{FT^\vee}[N, m_A; \vec{M}, \vec{T}] = \mathcal{Z}^{FT}[N, m_A; \vec{T}, \vec{M}] = \mathcal{Z}^{FT}[N, m_A; \vec{M}, \vec{T}]. \quad (5.8)$$

But this is immediate if we consider the identity for the duality between $FFT[\text{SU}(N+1)]$ and $T[\text{SU}(N+1)]^\vee$:¹⁴

$$\mathcal{Z}^{FFT}[N, m_A; \vec{M}, \vec{T}] = K'[\vec{T}, m_A] K'[\vec{M}, -m_A] \mathcal{Z}^T[N, -m_A; \vec{M}, \vec{T}] = \mathcal{Z}^T[N, -m_A; \vec{T}, \vec{M}]. \quad (5.9)$$

The additional flipping, which lead us to the spectral dual pair, is trivially implemented by moving the contribution of the singlets from the left to the right:

$$K[\vec{M}, -m_A] \mathcal{Z}^T[N, -m_A; \vec{M}, \vec{T}] = K[\vec{T}, -m_A] \mathcal{Z}^T[N, -m_A; \vec{T}, \vec{M}], \quad (5.10)$$

which up to $m_A \rightarrow -m_A$ is the identity we were looking for.

It is interesting to observe that $FT[\text{SU}(N+1)]$ and its spectral dual, similarly to $T[\text{SU}(N+1)]$ and its mirror dual, describe the low energy theory on a stack of D3 branes suspended between NS5 and D5 branes. Crucially, however, the IIB brane setup for $FT[\text{SU}(N+1)]$ involves D5 branes spanning the 012478 directions as shown in table 2 (see also figure 2), so we call them D5' to distinguish them from the ones relevant for $T[\text{SU}(N+1)]$ in figure 3. The difference between the two set-up is a “brane flip” — the D5' and D5 branes are transformed into each other under the exchange of directions 56 \leftrightarrow 78. The set-up in table 2 and figure 2, which preserves $\mathcal{N} = 2$ supersymmetry, is also invariant under the action of Type IIB S -duality which turns the NS5 branes into D5' branes leaving the D3 branes invariant and explains the spectral self-duality of $FT[\text{SU}(N+1)]$. Notice also that in the brane-realisation the $(N+1)^2$ singlets fields which flip the mesons correspond to the degrees of freedom of the D3 branes moving in directions 78 between two D5' branes (one hyper for each D3 segment) and between a D5' and an NS5 [46].

At this point it is tempting to speculate that performing also the flip of the CB moment map to obtain $FFT[\text{SU}(N+1)]$ corresponds to rotating also the NS5 into NS5'. This would give a new $\mathcal{N} = 4$ set-up with NS5' and D5' equivalent to the one in table 1 as consistent with the duality $FFT[\text{SU}(N+1)] \leftrightarrow T[\text{SU}(N+1)]$.

Coming back to the $\mathcal{N} = 2$ setup for $FT[\text{SU}(N+1)]$ now an interesting possibility arises. Consider the set-up in table 2 but *without* D3 branes. We assume for a moment

¹⁴In the $FFT[\text{SU}(N+1)]$ partition function we can equivalently use K or K' since the trace part will cancel out between the two set of singlets.

	0	1	2	3	4	5	6	7	8	9
NS5	–	–	–					–	–	–
D5'	–	–	–		–			–	–	
D3	–	–	–	–						

Table 2. The brane setup giving rise to the $3d$ $FT[SU(N + 1)]$ gauge theory.

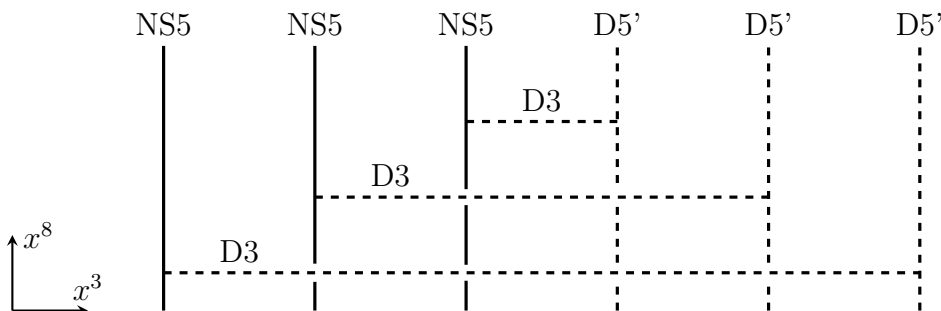

Figure 2. The brane setup giving rise to the $3d$ $FT[SU(3)]$ gauge theory. Notice that the NS5 and D5' branes form a (p, q) -brane web in the directions $(4, 9)$ (not shown) and coincide in the directions $(7, 8)$ (x^8 is vertical in the picture).

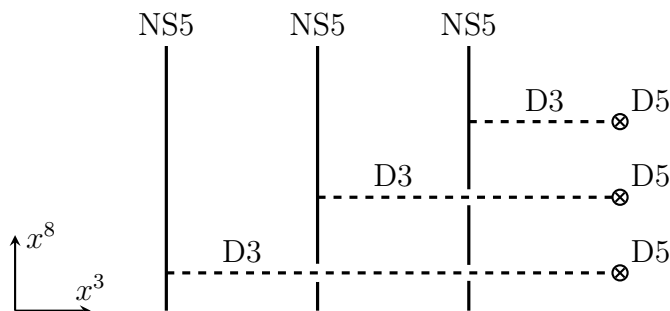

Figure 3. The brane setup giving rise to the $3d$ $T[SU(3)]$ gauge theory. The NS5 and D5 branes are perpendicular in all non-spacetime directions.

that all the five-branes sit at the same point in x^3 direction. The NS5 and D5' branes will form a (p, q) web in the 49 plane, as shown in figure 4(a) for the simplest example of $N = 1$.

The worldvolume theory on the five-branes is the $5d$ $\mathcal{N} = 1$ gauge theory living in the 01278 space. The positions of the five-branes in the 49 plane correspond to Coulomb moduli, couplings and masses of the gauge theory. In particular for the “square” (p, q) -web formed by $(N + 1)$ NS5 and $(N + 1)$ D5' the worldvolume theory is the $U(N + 1)^N$ $5d$ linear quiver theory with $(N + 1)$ fundamental hypermultiplets at each end.

If we now go to the Higgs branch of this $5d$ theory where the NS5 and D5' branes are separated in the x^3 direction we can stretch D3 branes between them as in figure 4(b), arriving precisely at the setup of table 2. Hence we explicitly realize the $FT[SU(N + 1)]$ theory as a defect theory appearing in the Higgs branch of the $5d$ theory. This realisation of $FT[SU(N + 1)]$ as a defect theory has been discussed extensively in section 3 of [25], here we summarize the salient points.

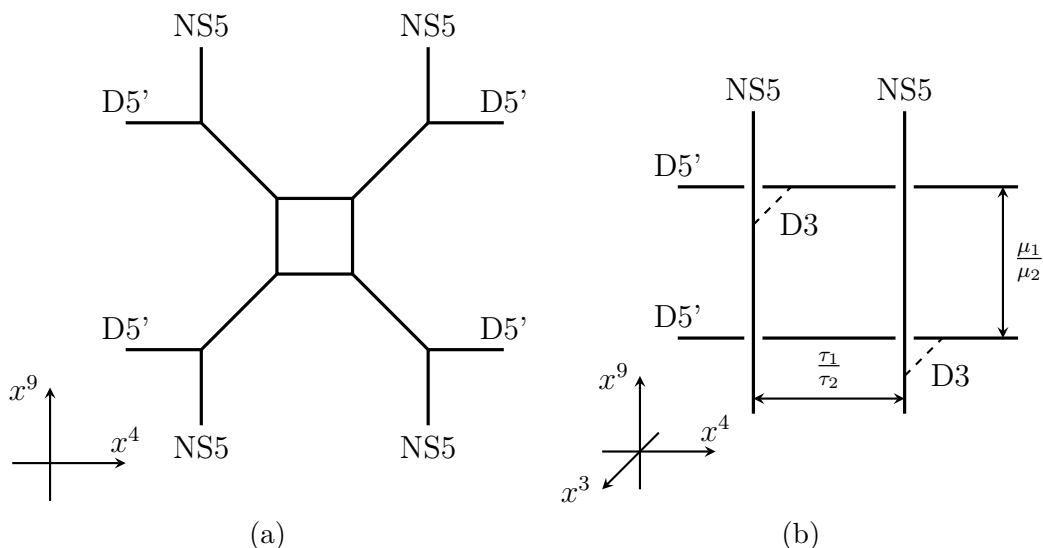

Figure 4. a) The (p, q) five-brane web formed by pairs of intersecting D5' and NS5 branes in the 49 plane, corresponding to the 5d $\mathcal{N} = 1$ SU(2) gauge theory with four fundamental hypermultiplets. b) The Higgs branch of the 5d theory corresponds to the configuration of five-branes separated along the x^3 direction. Here we consider the case where two D3 branes (here depicted as dashed lines) are stretching between the five-branes.

First of all there it was explicitly shown how the Higgsing prescription can be implemented starting from the topological string partition function for the toric CY \mathfrak{S} with square toric graph (with $(N + 1)$ vertical and $(N + 1)$ horizontal legs). In particular the partition function of $FT[\text{SU}(N + 1)]$ on $D^2 \times S^1$, evaluated on a reference contour α_0 $\mathcal{B}_{FT[\text{SU}(N+1)]}^{\alpha_0}(\vec{\mu}, \vec{\tau}, t)$ where the parameters μ_i, τ_j, t are exponentiated versions of M_i, T_j, m_A , is obtained from Z_{top}^S when the *complete* Higgsing pattern (eqs. (3.8) and (3.9) in [25]) $\mathfrak{S} \rightarrow \mathcal{S}$ is implemented:

$$\mathcal{B}_{FT[\text{SU}(N+1)]}^{\alpha_0}(\vec{\mu}, \vec{\tau}, t) = G Z_{1\text{-loop, top}}^S Z_{\text{vort, top}}^S(\vec{\mu}, \vec{\tau}, t), \quad (5.11)$$

where G is a fiber-base invariant factor. The parameters μ_i, τ_j are identified with Kähler parameters while the exponentiated axial mass t is identified with one of the equivariant Ω -background parameters on $\mathbb{R}_{q,t}^4 \times S^1$.

Then in [25] it was observed that the topological string partition function is invariant under fiber-base duality (which in the case of the *square* diagram \mathfrak{S} is *self*-duality) even after Higgsing:

$$Z_{1\text{-loop, top}}^S Z_{\text{vort, top}}^S(\vec{\mu}, \vec{\tau}, t) = Z_{1\text{-loop, top}}^{S'} Z_{\text{vort, top}}^{S'}(\vec{\mu}, \vec{\tau}, t), \quad (5.12)$$

which implies the 3d spectral self-duality of the 3d blocks:

$$\mathcal{B}_{FT[\text{SU}(N+1)]}^{\alpha_0}(\vec{\mu}, \vec{\tau}, t) = \mathcal{B}_{FT[\text{SU}(N+1)]}^{\alpha_0}(\vec{\tau}, \vec{\mu}, t) = \mathcal{B}_{FT[\text{SU}(N+1)]^{\vee}}^{\alpha_0}(\vec{\mu}, \vec{\tau}, t). \quad (5.13)$$

Fiber-base duality exchanges the Kähler parameters of the base with that of the fiber, thus it exchanges μ_i and τ_j , but t is left untouched since it is the parameter of the Ω -background (or, equivalently, the refinement parameter of refined topological string).

5.2 A new spectral dual pair

The reasoning that led us to state the spectral duality between $FT[\text{SU}(N+1)]$ and $FT[\text{SU}(N+1)]^\vee$ can be used on theory D and theory B to obtain a daughter spectral duality. Recall that theory D is SQED with $(N+1)$ flavors, U_i and \tilde{U}_i , mesonic and monopole flipping fields, and superpotential

$$W_D = m^\pm \sigma_\pm + \mathcal{U}_{ij}(F_D^{\mathcal{U}})_{ij} - \sum_{m=1}^N \frac{(-)^m}{m} \theta_m \text{Tr} \left[\underbrace{F_D^{\mathcal{U}} \dots F_D^{\mathcal{U}}}_{m \text{ times}} \right]. \quad (5.14)$$

The flipping fields σ_\pm and $F_{ij}^{\mathcal{U}}$ originated from Aharony duality on theory A .

To arrive at theory \mathcal{T} we flip the singlets σ_\pm and $\theta_{m \geq 2}$, since $\text{flip}^2 = 1$ we arrive at:

$$\mathcal{W}_{\mathcal{T}} = \phi(F_D^{\mathcal{U}})_{ii} + \mathcal{U}_{ij}(F_D^{\mathcal{U}})_{ij}, \quad (5.15)$$

where we redefined $\theta_1 = \phi$, for simplicity. We then can use the F-terms of ϕ and consider traceless flipping fields.

Theory \mathcal{T}' is obtained from theory B upon repeating the same two operations that define theory \mathcal{T} . From the operator map given in section 3.4, we see that the fields $\theta_{m \geq 2}$ correspond to dressed mesons of theory B :

$$\begin{aligned} \theta_2 &\leftrightarrow \tilde{d} \underbrace{\Omega_N \cdots \Omega_N}_{N-2 \text{ times}} d \\ &\vdots \\ \theta_N &\leftrightarrow \tilde{d} d \end{aligned} \quad (5.16)$$

while the monopoles σ^\pm are mapped to the two mesons $\tilde{d}p$ and $d\tilde{p}$. So we have:

$$\mathcal{W}_{\mathcal{T}'} = W_B + F_+ \tilde{d} p + F_- d \tilde{p} + \sum_{k=0}^{N-2} F_k \tilde{d} \Omega_N^k d \quad (5.17)$$

The equality of the partition functions $\mathcal{Z}_{\mathcal{T}} = \mathcal{Z}_{\mathcal{T}'}$ follows from the equality $\mathcal{Z}^D = \mathcal{Z}^B$ simply by reshuffling the flipping fields and we obtain:¹⁵

$$\begin{aligned} \mathcal{Z}_{\mathcal{T}} &= s_b(m_A) \prod_{a,b=1}^{N+1} s_b(-m_A + M_a - M_b) \int dx e^{-2\pi i \xi x} \prod_{a=1}^{N+1} s_b \left(\frac{iQ}{4} + \frac{m_A}{2} \pm (x_j - M_a) \right) \\ &= e^{-2\pi i M_{N+1} \xi} s_b \left(\frac{iQ}{2} - \frac{N+1}{2} \left(m_A + \frac{iQ}{2} \right) \pm \xi \right) \prod_{l=1}^{N-1} s_b \left(\frac{iQ}{2} - (l+1) \left(m_A + \frac{iQ}{2} \right) \right) \\ &\quad \times \int \prod_{k=1}^{N-1} dx^{(k)} e^{-2\pi i \zeta^{(k)} \sum_{a=1}^k x_a^{(k)}} Z_{\text{vec}}^{(k)} Z_{\text{adj}}^{(k)} Z_{\text{bif}}^{(k,k+1)} \int dx^{(N)} e^{-2\pi i \zeta^{(N)} \sum_{a=1}^N x_a^{(N)}} Z_{\text{vec}}^{(N)} Z_{\text{adj}}^{(N)} \\ &\quad \times \prod_{i=1}^N s_b \left(\frac{iQ}{4} + \frac{m_A}{2} \pm (x_i^{(N)} - \xi) \right) \prod_{i=1}^N s_b \left(\frac{N}{2} \left(m_A + \frac{iQ}{2} \right) \pm x_i^{(N)} \right) = \mathcal{Z}_{\mathcal{T}'} \quad (5.18) \end{aligned}$$

In the first line we can notice the cancellation of the trace-part of the flipping fields with the singlet ϕ .

¹⁵For later convenience we have changed the sign of ξ in $\mathcal{Z}_{\mathcal{T}}$. On the dual side $\mathcal{Z}_{\mathcal{T}'}$ we on top replacing $\xi \rightarrow -\xi$, we also change the signs of the integration variables $x_i^{(k)} \rightarrow -x_i^{(k)}$.

Holomorphic blocks. In this section realise theory \mathcal{T} and \mathcal{T}' as defect theories via Higgsing. First of all we need the holomorphic blocks, i.e. $D^2 \times S^1$ partition functions evaluated on a reference contour.

The block integrands $\Upsilon_{\mathcal{T}}$ and $\Upsilon_{\mathcal{T}'}$ can be easily obtained by taking the “square-root” of the S_b^3 integrand as observed in [42], and reviewed in [43]. Their explicit expression can be found in eqs. (C.1) and (C.3) in the appendix.

We then evaluate the block integrands on a basis of contours Γ_α with $\alpha = 1, \dots, N + 1$ which are in one-to-one correspondence with the $(N + 1)$ SUSY vacua of the theory. Similarly we will evaluate the block integrand for the spectral dual theory on a basis of contour to obtain the blocks $\mathcal{B}_{\mathcal{T}'}^\beta$:

$$\mathcal{B}_{\mathcal{T}}^\alpha = \oint_{\Gamma_\alpha} \Upsilon_{\mathcal{T}}, \quad \mathcal{B}_{\mathcal{T}'}^\beta = \oint_{\Gamma_\beta} \Upsilon_{\mathcal{T}'}. \tag{5.19}$$

Testing the spectral duality at the level of the blocks requires to establish a map between each element of the basis of theory \mathcal{T} and \mathcal{T}' . In terms of field theory objects, the matrix elements of this map are partition functions of $2d$ theories living on the interface between theory \mathcal{T} in vacuum α and \mathcal{T}' in vacuum β . Geometrically the interface is a torus $\partial(D_2 \times S^1) = T^2$, the equivariant parameter q of the $D_2 \times S^1$ background plays the role of the complex structure of the boundary torus and the $2d$ partition function is a version of elliptic index, hence expressed in terms of Jacobi theta-functions θ_q . However we will not be concerned with evaluating fully the matrix of transition coefficients.

We limit ourselves to the evaluation of the blocks of \mathcal{T} on a *reference* contour Γ_{α_0} . On the dual side we are able to identify the corresponding contour which we also call Γ_{α_0} . The details of the calculations can be found in the appendix, here we give the final result:

$$\mathcal{B}_{\mathcal{T}}^{\alpha_0} = \oint_{\Gamma_{\alpha_0}} \Upsilon_{\mathcal{T}} = \mathcal{E}_{\mathcal{T}} Z_{\text{cl},\mathcal{T}}^{\alpha_0} Z_{1\text{-loop},\mathcal{T}}^{\alpha_0} Z_{\text{vort},\mathcal{T}}^{\alpha_0}. \tag{5.20}$$

The explicit forms of $Z_{\text{cl},\mathcal{T}}^{\alpha_0} Z_{1\text{-loop},\mathcal{T}}^{\alpha_0}$ and $Z_{\text{vort},\mathcal{T}}^{\alpha_0}$ are given in in eqs. (C.11), (C.10). On the dual side we have:

$$\mathcal{B}_{\mathcal{T}'}^{\alpha_0} = \oint_{\Gamma_{\alpha_0}} \Upsilon_{\mathcal{T}'} = \mathcal{E}_{\mathcal{T}'} Z_{\text{cl},\mathcal{T}'}^{\alpha_0} Z_{1\text{-loop},\mathcal{T}'}^{\alpha_0} Z_{\text{vort},\mathcal{T}'}^{\alpha_0}. \tag{5.21}$$

The explicit forms of $Z_{\text{cl},\mathcal{T}'}^{\alpha_0} Z_{1\text{-loop},\mathcal{T}'}^{\alpha_0}$ and $Z_{\text{vort},\mathcal{T}'}^{\alpha_0}$ are given in eqs. (C.17), (C.15).

5.3 Spectral duality from fiber-base

In this section we explain how the $3d$ spectral duality between theories \mathcal{T} and \mathcal{T}' follows from fiber-base duality of refined topological string. First of all we need to establish the Higgsing prescription which allows us to obtain $\mathcal{B}_{\mathcal{T}}^\alpha$ and $\mathcal{B}_{\mathcal{T}'}^\alpha$, from refined topological string partition functions with tuned Kähler parameters.

Refined topological strings provide a deformation of the topological A-model partition function on toric CY threefolds. Apart from the exponentiated string coupling $q = e^{-g_s}$ the deformation depends on an additional parameter t , so that for $t = q$ the conventional

partition function is recovered. The rules for computing partition were introduced in [47]. Here we briefly recall that the main ingredient is the trivalent *refined vertex*

$$\begin{aligned}
 C_{ABC}(t, q) &= \begin{array}{c} \text{---} A \text{---} \\ \text{---} q \text{---} \\ \text{---} t \text{---} \\ \text{---} C \text{---} \\ \text{---} B \text{---} \end{array} \\
 &= q^{\frac{\|B\|^2 + \|C\|^2}{2}} t^{-\frac{\|B^T\|^2 + \|C^T\|^2}{2}} M_C^{(q,t)}(t^{-\rho}) \\
 &\quad \times \sum_D \left(\frac{q}{t}\right)^{\frac{|D| + |A| - |B|}{2}} \chi_{A^T/D}(q^{-C} t^{-\rho}) \chi_{B/D}(t^{-C^T} q^{-\rho}), \quad (5.22)
 \end{aligned}$$

associated to a vertex of the toric diagram, i.e. to a \mathbb{C}^3 patch. A , B and C are Young diagrams assigned to the intermediate legs of the toric diagram. In a generic toric diagram obtained gluing trivalent vertices, each intermediate leg is geometrically a compact 2-cycle \mathbb{P}^1 , to which corresponds a Kähler parameter $k = \int_{\mathbb{P}^1} \omega$, where ω is the Kähler form on the CY \mathcal{X} . k , together with the integral of the B -field $b = \int_{\mathbb{P}^1} B$ defines the exponentiated complexified Kähler parameter $Q = e^{-b+ik}$. The partition function is given by the sum of the product of refined topological vertices with additional weights of the form $Q^{|A|}$ for each intermediate leg. The sum is carried over all Young diagrams on the intermediate legs with empty diagrams assigned to the external legs.

It will be more convenient for us to use *spectral* parameters, assigned to all the legs of the diagram, instead of *Kähler* parameters associated only with the intermediate edges. Figure 5 explains the identification for the basic example we will need in our setup, the resolved conifold geometry. The piece of the partition function corresponding to the resolved conifold from figure 5 is given by

$$\begin{aligned}
 Z_{\text{conifold}} \left(\begin{array}{c} A \quad P \\ R \quad B \end{array} \middle| Q, q, t \right) &= \sum_C (-Q)^{|C|} C_{ACR}(t, q) C_{B^T C^T P^T}(q, t) \\
 &= Z \left(\begin{array}{c} \emptyset \\ \emptyset \\ \emptyset \end{array} \middle| Q, q, t \right) q^{\frac{\|R\|^2 - \|P\|^2}{2}} t^{\frac{\|P^T\|^2 - \|R^T\|^2}{2}} \left(\frac{q}{t}\right)^{\frac{|A| - |B|}{2}} \\
 &\quad \times M_R^{(q,t)}(t^{-\rho}) M_{P^T}^{(t,q)}(q^{-\rho}) G_{RP}^{(q,t)} \left(\sqrt{\frac{q}{t}} Q \right) \\
 &\quad \times \sum_C (-Q)^{|C|} \chi_{A^T/C^T} \left(p_n(t^{-\rho} q^{-R}) - p_n \left(\sqrt{\frac{q}{t}} Q t^{-\rho} q^{-P} \right) \right) \\
 &\quad \times \chi_{B/C} \left(p_n(q^{-\rho} t^{-P^T}) - p_n \left(\sqrt{\frac{t}{q}} Q q^{-\rho} t^{-R^T} \right) \right) \quad (5.23)
 \end{aligned}$$

In what follows we normalize Z_{conifold} so that it is an identity when all the external legs are empty, i.e. we divide by $Z \left(\begin{array}{c} \emptyset \\ \emptyset \\ \emptyset \end{array} \middle| Q, q, t \right)$.

The crucial point for our Higgsing construction is that for quantized Q the function (5.23) actually vanishes for a large subset of “boundary conditions” (external Young

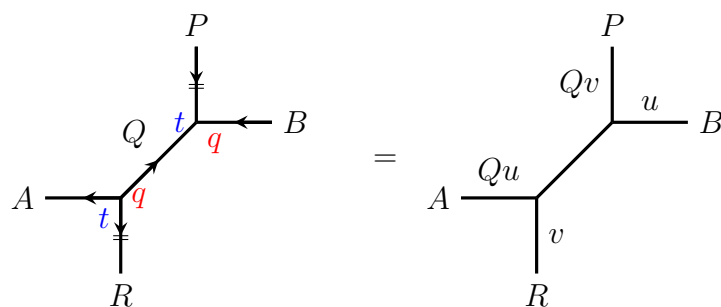

Figure 5. Resolved conifold geometry in refined topological strings. The double ticks denote the preferred direction, and t and q indicate the respective legs of the refined topological vertices. Q is the exponentiated complexified Kähler parameter of the base \mathbb{P}^1 (drawn as an intermediate diagonal edge). A , B , P and R are Young diagrams associated with the outer legs. The right picture is the simplification of the left one with spectral parameters on the legs playing the roles of Kähler parameters.

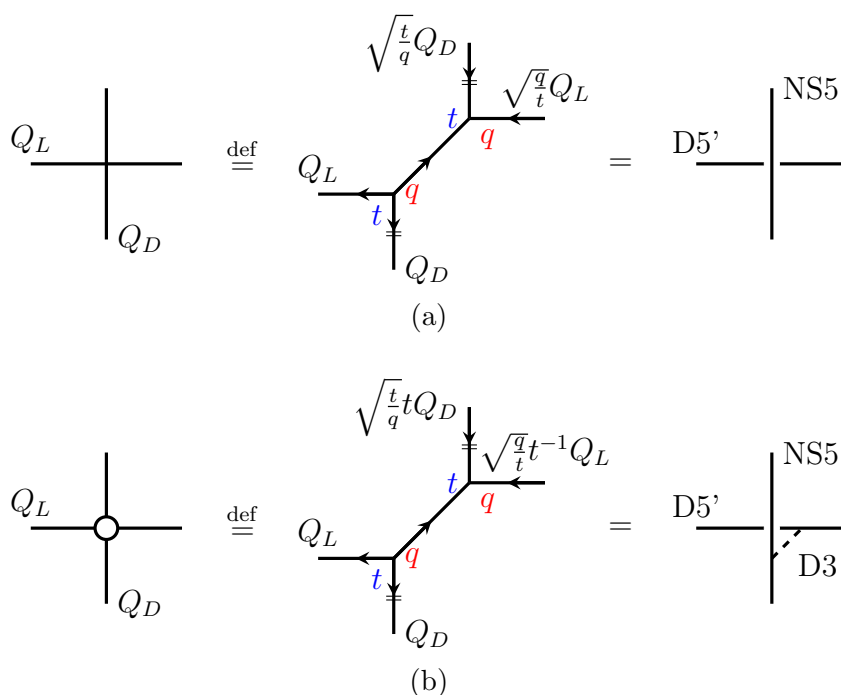

Figure 6. Higgsing of the resolved conifold geometry leading to two different types of crossings. Notice the particular values of the Kähler parameters on the legs. (a) An “empty” crossing, i.e. without D3 branes stretched between the NS5 and D5’. (b) a “full” crossing, i.e. with one D3 brane stretched between the NS5 and D5’.

diagrams). Namely for the situation pictured in figure 6, the *lengths* of the diagrams on the vertical leg before and after the crossing are constrained as follows:

$$\text{for } \begin{array}{c} W \\ | \\ Q_L \text{---} \text{---} \\ | \\ Y \text{---} Q_D \\ | \\ W \end{array} \quad l(W) \leq l(Y), \quad (5.24)$$

$$\text{for } \begin{array}{c} W \\ | \\ Q_L \text{---} \text{---} \bigcirc \\ | \\ Y \text{---} Q_D \end{array} \quad l(W) \leq l(Y) + 1. \quad (5.25)$$

These constraints are valid irrespective of the diagrams propagating on the *horizontal* leg. For example if the resolved conifold fragment (5.24) sits in the lowest part of the diagram, then $Y = \emptyset$ since it corresponds to an external leg, and therefore W is constrained to be empty. The block (5.25) in the same situation would constraint the diagram W to have just one column, i.e. $W = [k]$, $k \in \mathbb{Z}_{\geq 0}$. The integers k in this construction will correspond to the summation variables in the 3d vortex series.

We will denote the ‘‘Higgsed’’ CY manifold (i.e. the CY with discrete choice of Kähler parameters) corresponding to the 3d theory \mathcal{T} by \mathcal{Y} and that corresponding to \mathcal{T}' by \mathcal{Y}' . Of course, \mathcal{Y}' is the fiber-base dual (the mirror image along the diagonal) of \mathcal{Y} . Below we give some details of the topological string computations for \mathcal{Y} and \mathcal{Y}' .

CY \mathcal{Y} . The toric diagram for the CY \mathcal{Y} in the case $N = 4$ looks as follows:

$$\begin{aligned} Z_{\text{top}}^{\mathcal{Y}}(\vec{\mu}, \vec{\tau}, q, t) &= \begin{array}{c} \begin{array}{ccccccc} & & & & & & \tau_2 \\ & & & & & & | \\ \bigcirc & \bigcirc & \bigcirc & \bigcirc & & & [k] \\ | & | & | & | & & & | \\ \emptyset & \emptyset & \emptyset & \emptyset & & & \tau_1 \\ | & | & | & | & & & | \\ \mu_5 & \mu_4 & \mu_3 & \mu_2 & & & \mu_1 \end{array} \\ \\ &= Z_{\text{top},1\text{-loop}}^{\mathcal{Y}}(\vec{\mu}, \xi, q, t) Z_{\text{vortex}}^{\mathcal{Y}}(\vec{\mu}, \xi, q, t). \end{array} \quad (5.26) \end{aligned}$$

where $\tau_1 = e^{2\pi b\xi}$, $\tau_2 = t^{\frac{1-N}{2}}$. Here we have explicitly indicated the Young diagrams propagating on the intermediate vertical legs. These diagrams are constrained by the rules, (5.24), (5.25), so that $[k]$ is the single column Young diagram. It is this variable over which the summation in the vortex series is performed. We normalize our partition function so that $Z_{\text{vortex}}^{\mathcal{Y}}(\vec{\mu}, \xi, q, t)$ is a series in $e^{2\pi b\xi}$ which starts with identity. The partition function can then be computed explicitly e.g. using the resolved conifold formula from eq. (5.23)¹⁶ and the result coincides with the series vortex series (C.10).

The relative prefactor $Z_{\text{top},1\text{-loop}}^{\mathcal{Y}}(\vec{\mu}, \xi, q, t)$ is easy to calculate — it is what remains of the partition function when $\frac{\tau_1}{\tau_2}$ goes to zero. This limit corresponds to an infinitely large

¹⁶There is, however, a more compact and convenient operator product technique [48–50], which we don’t present here not to overcomplicate the presentation with technicalities.

Kähler parameter between the two horizontal legs in (5.26), so that the diagram splits into a product of two horizontal strip partition functions. Indeed, in this limit only $k = 0$ contributes and we have:

$$Z_{\text{top},1\text{-loop}}^{\mathcal{Y}}(\vec{\mu}, \xi, q, t) = \sqrt{\frac{t}{q}}\mu_5 \sqrt{\frac{t}{q}}\mu_4 \sqrt{\frac{t}{q}}\mu_3 \sqrt{\frac{t}{q}}\mu_2 \sqrt{\frac{t}{q}}t\mu_1. \tag{5.27}$$

Here we have written out the spectral parameter of the vertical legs explicitly. The well-known formula for the refined strip partition function gives [51]:

$$Z_{\text{top},1\text{-loop}}^{\mathcal{Y}}(\vec{\mu}, \xi, q, t) = \prod_{i=2}^{N+1} \prod_{j=i+1}^{N+1} \frac{\left(\frac{q}{t} \frac{\mu_i}{\mu_j}; q\right)_{\infty}}{\left(t \frac{\mu_i}{\mu_j}; q\right)_{\infty}} \prod_{k=2}^{N+1} \frac{\left(q \frac{\mu_1}{\mu_k}; q\right)_{\infty}}{\left(t \frac{\mu_1}{\mu_k}; q\right)_{\infty}}. \tag{5.28}$$

CY \mathcal{Y}' . The toric diagram for the spectral dual CY \mathcal{Y}' is simply the mirror image along the diagonal of that of \mathcal{Y} (5.26), so that:

$$Z_{\text{top},1\text{-loop}}^{\mathcal{Y}'}(\vec{\mu}, \vec{\tau}, q, t) Z_{\text{vortex}}^{\mathcal{Y}'}(\vec{\mu}, \vec{\tau}, q, t) = \tag{5.29}$$

Here we have again used the rules (5.24), (5.25) to constraint the Young diagrams on the vertical legs. The integers $k_i^{(a)}$ are precisely the integers in the 3d vortex sum and $Z_{\text{vortex}}^{\mathcal{Y}'}$ can be checked to reproduce (C.15).

The computation of the one-loop factor is similar to section 5.3: the toric diagram in the limit $\frac{\tau_a}{\tau_{a+1}} \rightarrow 0$ splits into $(N + 1)$ horizontal strips. Using the result for the strips we obtain

$$Z_{\text{top},1\text{-loop}}^{\mathcal{Y}'}(\vec{\mu}, \vec{\tau}, q, t) = \frac{\left(qt^{\frac{N-1}{2}} e^{2\pi\beta\xi}; q\right)_{\infty}}{\left(t^{\frac{N+1}{2}} e^{2\pi\beta\xi}; q\right)_{\infty}}. \tag{5.30}$$

The fiber-base duality of the topological string partition function (after Higgsing) yields the following equality:

$$Z_{1\text{-loop},\text{top}}^{\mathcal{Y}} Z_{\text{vort},\text{top}}^{\mathcal{Y}} = Z_{1\text{-loop},\text{top}}^{\mathcal{Y}'} Z_{\text{vort},\text{top}}^{\mathcal{Y}'} \tag{5.31}$$

A simple brute force check of eq. (5.31) to lower orders in the Kähler parameters is given in appendix D.

Match of field theory with Z_{top} . Finally we relate our gauge theory results for the holomorphic blocks with the results of the Higgsing prescription. We find that:

$$\mathcal{B}_{\mathcal{T}}^{\alpha_0} = \mathcal{E}_{\mathcal{T}} Z_{\text{cl},\mathcal{T}}^{\alpha_0} Z_{1\text{-loop},\mathcal{T}}^{\alpha_0} Z_{\text{vort},\mathcal{T}}^{\alpha_0} = G_{\mathcal{T}} Z_{1\text{-loop,top}}^{\mathcal{Y}} Z_{\text{vort,top}}^{\mathcal{Y}} \quad (5.32)$$

and

$$\mathcal{B}_{\mathcal{T}'}^{\alpha_0} = \mathcal{E}_{\mathcal{T}'} Z_{\text{cl},\mathcal{T}'}^{\alpha_0} Z_{1\text{-loop},\mathcal{T}'}^{\alpha_0} Z_{\text{vort},\mathcal{T}'}^{\alpha_0} = G_{\mathcal{T}'} Z_{1\text{-loop,top}}^{\mathcal{Y}'} Z_{\text{vort,top}}^{\mathcal{Y}'}, \quad (5.33)$$

where $G_{\mathcal{T}}, G_{\mathcal{T}'}$ denote fiber-base invariant prefactors.

Since we checked the fiber-base duality of the refined string eq. (5.31) we are left to check that:

$$\frac{G_{\mathcal{T}}}{G_{\mathcal{T}'}} = 1, \quad (5.34)$$

or

$$\frac{\mathcal{E}_{\mathcal{T}} Z_{\text{cl},\mathcal{T}}^{\alpha_0} Z_{1\text{-loop},\mathcal{T}}^{\alpha_0} Z_{1\text{-loop,top}}^{\mathcal{Y}'}}{\mathcal{E}_{\mathcal{T}'} Z_{\text{cl},\mathcal{T}'}^{\alpha_0} Z_{1\text{-loop},\mathcal{T}'}^{\alpha_0} Z_{1\text{-loop,top}}^{\mathcal{Y}}} = 1. \quad (5.35)$$

In fact eqs. (5.35), (5.34) can be relaxed slightly: the r.h.s. can be a q -periodic function, e.g. a combination of θ_q -functions which also becomes an identity when glued into the S_b^3 partition function. Notice that the topological string partition function lacks the classical (i.e. power function) part, so the relation (5.35) is essentially the requirement that the *classical* part of the field theory holomorphic block be fiber-base duality invariant on its own.

We evaluate (5.35) in two steps. We combine eqs. (C.2), (C.8), (5.28) to get

$$\begin{aligned} \frac{Z_{\text{cl},\mathcal{T}}^{\alpha_0} Z_{1\text{-loop},\mathcal{T}}^{\alpha_0}}{Z_{1\text{-loop,top}}^{\mathcal{Y}}} &= \frac{\mathcal{F}_{\mathcal{T}} \mathcal{I}_{0,\mathcal{T}}^{\alpha_0}(\vec{\mu}, \xi, q, t)}{Z_{1\text{-loop,top}}^{\mathcal{Y}}} \\ &= \frac{1}{(t)_{\infty}^N} e^{-2\pi i b M_1 \xi - \pi b \beta (N+1) M_1} \prod_{k=2}^{N+1} \frac{\theta_q\left(t \frac{\mu_k}{\mu_1}\right)}{\theta_q\left(\frac{\mu_k}{\mu_1}\right)} \prod_{i>j}^{N+1} \frac{\theta_q\left(\frac{q \mu_i}{t \mu_j}\right)}{\theta_q\left(t \frac{\mu_i}{\mu_j}\right)} \\ &\sim \frac{e^{-2\pi i b M_1 \xi + \pi b \beta (N+1) M_1 - 2\pi b \beta \sum_{k=1}^{N+1} M_k + 2\pi b (1-2\beta) \sum_{j=1}^{N+1} M_j (N+2-2j)}}{(t)_{\infty}^N}. \end{aligned} \quad (5.36)$$

where the last equality is up to q -periodic function of μ_k . Similarly we combine eqs. (C.5), (C.14), (5.30) and obtain

$$\begin{aligned} \frac{Z_{\text{cl},\mathcal{T}'}^{\alpha_0} Z_{1\text{-loop},\mathcal{T}'}^{\alpha_0}}{Z_{1\text{-loop,top}}^{\mathcal{Y}'}} &= \frac{\mathcal{F}_{\mathcal{T}'} \mathcal{I}_{0,\mathcal{T}'}^{\alpha_0}(\vec{\mu}, \xi, q, t)}{Z_{1\text{-loop,top}}^{\mathcal{Y}'}} \\ &= \frac{1}{(t)_{\infty}^N} e^{\pi i b^2 \beta^2 \frac{N(N^2-1)}{6} + \pi b \beta (N+1) M_1 + \pi b \beta \sum_{a=1}^{N+1} (2a-3-N) M_a} \\ &\quad \times e^{-2\pi i \xi (M_1 - M_{N+1} - i b \beta N)} \frac{\theta_q\left(t \frac{N+1}{2} e^{2\pi b \xi}\right)}{\theta_q\left(q t \frac{N-1}{2} e^{2\pi b \xi}\right)} \\ &\sim \frac{1}{(t)_{\infty}^N} e^{\pi i b^2 \beta^2 \frac{N(N^2-1)}{6} + \pi b \beta (N+1) M_1 + \pi b \beta \sum_{a=1}^{N+1} (2a-3-N) M_a} \\ &\quad \times e^{-2\pi i \xi (M_1 - M_{N+1} - i b \beta N) + 2\pi b \xi (1-\beta)}. \end{aligned} \quad (5.37)$$

Dividing eq. (5.36) by eq. (5.37) we get

$$\frac{Z_{\text{cl},\mathcal{T}}^{\alpha_0} Z_{1\text{-loop},\mathcal{T}}^{\alpha_0}}{Z_{1\text{-loop},\text{top}}^{\mathcal{Y}}} \frac{Z_{1\text{-loop},\text{top}}^{\mathcal{Y}'}}{Z_{\text{cl},\mathcal{T}'}^{\alpha_0} Z_{1\text{-loop},\mathcal{T}'}^{\alpha_0}} \sim e^{-\pi i b^2 \beta^2 \frac{N(N^2-1)}{6} + \pi b \beta \sum_{a=1}^{N+1} (N+1-2a) M_a - 2\pi i \xi (M_{N+1} + i b \beta N)} \times e^{-2\pi b \xi (1-\beta) + 2\pi b (1-2\beta) \sum_{j=1}^{N+1} M_j (N+2-2j)}. \quad (5.38)$$

Thus, to get the invariance we need to have

$$\frac{\mathcal{E}_{\mathcal{T}'}}{\mathcal{E}_{\mathcal{T}}} = \exp \left[-2\pi i \xi M_{N+1} - \pi b \beta \sum_{k=1}^{N+1} (2k - N - 1) M_k + 2\pi b (1 - 2\beta) \sum_{j=1}^{N+1} M_j (N + 2 - 2j) + 2\pi b (\beta (N + 1) - 1) \xi - \frac{\pi i b^2 \beta^2}{6} N (N^2 - 1) \right]. \quad (5.39)$$

And indeed we obtained the ratio of the contact terms as a determined from the gauge theory partition function calculation in eq. (C.6) in the appendix C.

We have thus established the spectral duality for theories \mathcal{T} and \mathcal{T}' using topological string computation. It is remarkable that the field theory computation matches the topological string not only qualitatively but with such a *quantitative* finesse.

Acknowledgments

We are very grateful to Sergio Benvenuti, Noppadol Mekareeya, Simone Giacomelli and Matteo Sacchi for enlightening discussions. We are especially thankful to Alberto Zaffaroni for several illuminating comments during the various stages of this work. FA acknowledges Galileo Galilei Institute for Theoretical Physics for hospitality during the workshop ‘Supersymmetric Quantum Field Theories in the Non-perturbative Regime’. YZ is partly supported by RFBR grants 17-01-00585, 17-51-50051_YaF, 18-51-05015_Arm. FA, SP, and YZ are supported by the ERC-STG grant 637844-HBQFTNCER and by the INFN.

A More details on nilpotent Higgsing

We describe some additional details of the Higgsing process studied in section 3.3.

Let us recall our notation for Theory C : bifundamentals of type S transform in the $(\square, \bar{\square})$ of $U(k) \times U(k+1)$. Bifundamentals of type \tilde{S} transform in the $(\square, \bar{\square})$ of $U(k+1) \times U(k)$. In matrix notation, the reps are

$$\square = \begin{bmatrix} v_1 \\ \vdots \\ v_k \end{bmatrix} \quad \bar{\square} = [v_1, \dots, v_{k+1}] \quad (A.1)$$

Covariant derivatives $DS^{(k,k+1)}$ and $D\tilde{S}^{(k,k+1)}$, on a link $(k, k+1)$, with $U(k)$ connection on the left and $U(k+1)$ on the right, are defined as usual as

$$DS^{(k,k+1)} = dS - i\mathcal{A}_k S^{(k,k+1)} + S^{(k,k+1)} i\mathcal{A}_{k+1}, \quad (A.2)$$

$$D\tilde{S}^{(k,k+1)} = dS + \tilde{S}^{(k,k+1)} i\mathcal{A}_k - i\mathcal{A}_{k+1} \tilde{S}^{(k,k+1)}. \quad (A.3)$$

The two objects $D_\mu S^{(k,k+1)}$ and $D_\mu \tilde{S}^{(k,k+1)}$, are themselves bifundamentals. The covariant derivative for the adjoint scalars on a node $U(k)$ is

$$D\Psi_k = d\Psi_k - i[\mathcal{A}_k, \Psi_k]. \tag{A.4}$$

Nilpotent vev and D-terms. We discussed in the main text the role of D-terms in the solution of our nilpotent vev. Our notation for a D-term there was the following: for a gauge node $U(k)$, with bifundamentals on the left, $L = (k-1, k)$, and on the right, $R = (k, k+1)$, we have

$$D^a = D^a \Big|_{\text{hyper}} + \text{Tr}_k(T^a[\Psi_k^\dagger, \Psi_k]) \tag{A.5}$$

$$D^a \Big|_{\text{hyper}} = \text{Tr}_k \left(T^a \left(S^R S^{R\dagger} - \tilde{S}^{R\dagger} \tilde{S}^R + \tilde{S}^L \tilde{S}^{L\dagger} - S^{L\dagger} S^L \right) \right) \tag{A.6}$$

Then, it is straightforward to compute on the nilpotent vev (3.60) the following matrix products

$$S^{(k-1,k)\dagger} S^{(k-1,k)} = \text{diag}(0^2, 1^{k-2}), \tag{A.7}$$

$$S^{(k-1,k)} S^{(k-1,k)\dagger} = \text{diag}(0^1, 1^{k-2}) = \tilde{S}^{(k,k-1)\dagger} \tilde{S}^{(k,k-1)} \tag{A.8}$$

$$\tilde{S}^{(k-1,k)} \tilde{S}^{(k-1,k)\dagger} = \text{diag}(0, 1^{k-2}, 0) \tag{A.9}$$

Gauge multiplets mass matrix. Given the Lagrangian of the theory, the mass matrix for spin-1 fields can be obtained from the covariant derivatives of the charged fields. We expect that the bifundamentals S and \tilde{S} , whose kinetic term is

$$\text{Tr}_{k+1} \left[(D_\mu S)^\dagger (D_\mu S) + (D_\mu \tilde{S})(D_\mu \tilde{S})^\dagger \right]$$

will be responsible for mass terms between different gauge nodes. We quote the form of the mass matrix coming from the bifundamentals $S^{(k,k+1)}$, since it is instructive:

$$\sum_{k=1}^N \left[\mathcal{A}_k^a, \mathcal{A}_{k+1}^a \right] \text{Tr} \otimes \begin{bmatrix} T_k^a S^{(k,k+1)} S^{(k,k+1)\dagger} T_k^b & S^{(k,k+1)\dagger} T_k^a S^{(k,k+1)} T_{k+1}^b \\ T_k^b S^{(k,k+1)} T_{k+1}^a S^{(k,k+1)\dagger} & T_{k+1}^a S^{(k,k+1)\dagger} S^{(k,k+1)} T_{k+1}^b \end{bmatrix} \begin{bmatrix} \mathcal{A}_k^b \\ \mathcal{A}_{k+1}^b \end{bmatrix} \tag{A.10}$$

In this formula $\mathcal{A}_{N+1} = 0$ since the last node is a flavor node, i.e. it is ungauged. Matrix elements are understood on the nilpotent vev. The contribution of \tilde{S} -type bifundamentals is similar to (A.10). Then, if we split the total mass matrix into the contributions of S , \tilde{S} , and Φ , adjoint fields will not couple different gauge nodes.

The total mass matrix has the following block structure,

$$\left(\begin{array}{c|c|c|c|c|c|c} \text{U}(1) & 0 & 0 & 0 & 0 & 0 & \dots \\ \hline 0 & \text{U}(2) & \times & 0 & 0 & 0 & \dots \\ \hline 0 & \times & \text{U}(3) & \times & 0 & 0 & \dots \\ \hline 0 & 0 & \times & \text{U}(4) & \times & 0 & \dots \\ \hline 0 & 0 & 0 & \times & \dots & \dots & \dots \end{array} \right) \tag{A.11}$$

with non zero crossed blocks. This structure resemble indeed that of the quiver: all but the first gauge node get two contributions, one from bifundamentals on the left, one from the right.

After careful evaluation of (A.11) we were able to double-check the solution quoted in (3.73). This same solution can then be understood in a simpler way by thinking about the action of broken gauge generators, along the lines of what we stated in section 3.3.

A basis for massive chiral fields. When discussing Theory C we described, within the set of UV fields, an explicit basis for the massless fields on the nilpotent vev. This basis contained two subspaces: physical IR massless fields and goldstone bosons. In the physical sector we then had a further splitting: bifundamentals, and adjoints. This splitting is orthogonal by default. However, physical massless fields are not orthogonal to goldstone bosons. (This is OK, since both are in the kernel of the matrix, and it might happen that is just convenient, but not needed, that physical massless are taken to be orthogonal among themselves).

In order to obtain a basis for massive chiral fields we can adopt the following strategy.

- We split the set of UV fields, call them \mathcal{B} , into the set of physical IR fields and its orthogonal, hereafter denoted by \mathcal{K}^\perp . (This is not \ker^\perp). The only non trivial construction in \mathcal{K}^\perp regards the adjoints, since as we mentioned, bifundamentals and adjoints are orthogonal by default. In practise we construct

$$\mathcal{B} = \{v_1 \dots, v_{\#_{ir}}\} \cup \{v_{\#_{ir+1}}, \dots, v_{\#_{uv}}\} \tag{A.12}$$

where the first set contains only physical massless fields in the IR. We check that $\{v_1 \dots, v_{\#_{ir}}\} \cup \{\text{goldstone bosons}\}$ is a set of independent fields.¹⁷ Given $\mathcal{K}^\perp = \{v_{\#_{ir+1}}, \dots, v_{\#_{uv}}\}$, then we know that $\{\text{goldstone bosons}\} \subset \mathcal{K}^\perp$. We do not impose orthogonality among the vectors in $\{v_{\#_{ir+1}}, \dots, v_{\#_{uv}}\}$.

- For each goldstone boson, call it G_k , we impose the orthogonality condition

$$G_k v = 0 \quad v = \sum_{j \in \mathcal{K}^\perp} \alpha_j v_j \tag{A.13}$$

These linear equations fix a number of parameters equal to the number of goldstone bosons. The resulting free parameters provide a span for the massive fields, i.e. the actual \ker^\perp . Vectors in this basis are not orthogonal among themselves, but they are automatically orthogonal to physical massless fields which is what we were looking for. Concluding we have splitted \mathcal{B} in the form

$$\mathcal{B} = \underbrace{\mathcal{K} \oplus G}_{\ker} \oplus \ker^\perp \tag{A.14}$$

Let us come back on the first part of this construction, i.e. a convenient basis for adjoint fields. Note indeed that massless IR fields in the adjoint are not directly aligned with a basis of hermitian matrices for $U(N)$, so it is better to use an alternative basis. Consider the map $\iota_k : \mathbb{R}^{d \times d} \rightarrow \mathbb{R}^k$ with $k \leq d$ defined as

$$\iota_k \cdot \begin{bmatrix} a_{1,1} & a_{1,2} & \dots & \dots & a_{1,d} \\ a_{2,1} & a_{2,2} & a_{2,3} & \dots & a_{2,d} \\ \vdots & \vdots & \vdots & \vdots & \vdots \end{bmatrix} = \begin{bmatrix} a_{1,d-k+1} \\ a_{2,d-k+2} \\ \vdots \end{bmatrix} \tag{A.15}$$

¹⁷For example we show that there is no non trivial solution to $\sum_{i=1}^{\#_{ir}} x_i v_i + \sum_{k=2}^N G_k = 0$.

For example, if $k = d$, the map ι_d returns the diagonal of the matrix. We can find a basis for $\mathbb{R}^{d \times d}$ by considering for each $k \leq d$ an orthogonal basis of \mathbb{R}^k of the form,

$$\begin{bmatrix} 1 \\ 1 \\ \vdots \\ 1 \end{bmatrix}, \begin{bmatrix} +1 \\ -1 \\ 0 \\ \vdots \end{bmatrix}, \dots \quad (\text{A.16})$$

Then, for each node $U(n)$ we construct a basis Φ_n of the adjoint rep recursively. Define Φ_{n-1} to be the basis of $U(n-1)$ built out of ι_k for $k \leq n-1$. We can embed Φ_{n-1} in Φ_n in two ways

$$\Phi_n \supset \begin{pmatrix} 0 & 0 \\ 0 & \Phi_{n-1} \end{pmatrix} \quad \text{or} \quad \Phi_n \supset \begin{pmatrix} \Phi_{n-1} & 0 \\ 0 & 0 \end{pmatrix} \quad (\text{A.17})$$

The embedding on the right of (A.17) will be needed for the $U(N+1)$ flavor node. The other one is used on the gauge nodes of the tail. In order to find a complete orthogonal basis we only need elements parametrizing the remaining row and a column of Φ_n . Finally we normalize. The basis $\bigoplus_{n=1}^{N+1} \Phi_n$ parametrize the $2N+3$ fields $\{\Gamma_i, \psi_k, \Sigma_{\pm}, \delta\}$, in a natural way. A basis orthogonal to these $2N+3$ fields is also simple to construct.

More general nilpotent deformations. The nilpotent vev we studied, together with the Higgsing, can be generalized outside next-to-extremality. For example, let us label the F-term deformation generated by the monopoles using a partition, i.e. the following set of integers: $\mathcal{I} = \{n_1, \dots, n_N\}$ with $n_i \geq 0$ and $\sum_{l=1}^N l n_l = N$. In (3.57) we considered $\mathcal{I} = (0^{N-1}, 1)$, which naturally generalize to,

$$\text{Tr}_N \mathbb{S}^{(N, N+1)} = \bigoplus_{l=1}^N \mathbb{J}_l^{\oplus n_l} \oplus \mathbb{J}_1 \quad (\text{A.18})$$

This equation is solved block by block in the same way as in (3.58). Then

$$\begin{aligned} \langle \tilde{\mathcal{S}}^{(N, N+1)} \rangle &= \bigoplus_{l=1}^N \mathbb{J}_l^{\oplus n_l} \oplus \mathbb{J}_1 && \text{drop the last column.} \\ \langle \mathcal{S}^{(N, N+1)} \rangle &= \bigoplus_{l=1}^N (\mathbb{J}_1 \oplus \mathbb{I}_{l-1})^{\oplus n_l} \oplus \mathbb{J}_1 && \text{drop the last row.} \end{aligned} \quad (\text{A.19})$$

and

$$\begin{aligned} \langle \tilde{\mathcal{S}}^{(N-k, N+1-k)} \rangle &= \bigoplus_{l=1}^N (\mathbb{J}_1^{\oplus k} \oplus \mathbb{J}_{l-k})^{\oplus n_l} && \text{drop the first } k \text{ column and } k-1 \text{ rows} \\ \langle \mathcal{S}^{(N-k, N+1-k)} \rangle &= \bigoplus_{l=1}^N (\mathbb{J}_1^{\oplus k} \oplus \mathbb{J}_1 \oplus \mathbb{I}_{k-2})^{\oplus n_l} && \text{drop the first } k \text{ row and } k-1 \text{ columns} \end{aligned} \quad (\text{A.20})$$

B Bookkeeping integrals

In this appendix we collect some useful results about hyperbolic integrals.

Double-sine function. The double-sine function, s_b , appeared in the very first computation of [37], as a building block for the localized partition function of $3d \mathcal{N} = 2$ theories on the squashed sphere S_b^3 . It can be introduced with an infinite product representation, which is perhaps familiar to the physics literature,

$$s_b = \prod_{m,n \geq 0} \frac{mb + n/b + Q/2 - ix}{mb + n/b + Q/2 + ix}, \quad Q = b + b^{-1}. \quad (\text{B.1})$$

It satisfies the following non trivial properties

$$s_b(x)s_b(-x) = 1 \quad (\text{B.2})$$

$$s_b\left(\frac{ib}{2} - x\right)s_b\left(\frac{ib}{2} + x\right) = \frac{1}{2 \cosh(\pi bx)} \quad (\text{B.3})$$

$$s_b(x) = e^{+\frac{i\pi}{2} B_{22}[Q/2-ix]} (e^{2\pi ib(Q/2-ix)}, q)_\infty (e^{2\pi i/b(Q/2-ix)}, \tilde{q})_\infty \quad (\text{B.4})$$

$$= e^{-\frac{i\pi}{2} B_{22}[Q/2+ix]} (e^{2\pi ib(Q/2+ix)}, q)_\infty^{-1} (e^{2\pi i/b(Q/2+ix)}, \tilde{q})_\infty^{-1} \quad (\text{B.5})$$

where $q \equiv e^{2i\pi b^2} = e^{2i\pi bQ}$, $\tilde{q} \equiv e^{\frac{2i\pi}{b^2}} = e^{2i\pi/bQ}$. The Bernulli numbers relevant to the factorization formulas are

$$B_{22}(x) = (x - Q/2)^2 - (b^2 + b^{-2})/12. \quad (\text{B.6})$$

A slightly more compact notation distinguishes s_b with argument $x \pm iQ/2$, i.e.

$$\overline{s_b} \equiv s_b\left(x + \frac{iQ}{2}\right)^{+1}, \quad \underline{s_b} \equiv s_b\left(x - \frac{iQ}{2}\right)^{-1}. \quad (\text{B.7})$$

Then, we find

$$\frac{\overline{s_b}(x + \frac{mi}{b} + nib)}{\overline{s_b}(x)} = \frac{(-)^{nm+n+m} q^{\frac{n(n+1)}{4}} \tilde{q}^{\frac{m(m+1)}{4}} e^{+\pi nbx + \frac{\pi mx}{b}}}{(qe^{2\pi bx}, q)_n (\tilde{q}e^{\frac{2\pi x}{b}}, \tilde{q})_m} \quad (\text{B.8})$$

$$\frac{\underline{s_b}(x + inb + \frac{im}{b})}{\underline{s_b}(x)} = \frac{(e^{2\pi bx}, q)_n (e^{\frac{2\pi x}{b}}, \tilde{q})_m}{(-)^{nm+m+n} q^{\frac{n(n+1)}{4}} \tilde{q}^{\frac{m(m+1)}{4}} e^{\pi b(x-iQ)n + \frac{\pi m(x-iQ)}{b}}} \quad (\text{B.9})$$

Abelian integrals. In section 4.5 we studied in details the commutative diagram for $T[\text{SU}(2)]$. The computations involving $T[\text{SU}(2)]$ reduce to abelian integrals of the form

$$\int dx z^x \prod_{i=1}^{N_f} \frac{s_b(x + M_i + u_i + \frac{iQ}{2})}{s_b(x + M_i - u_i - \frac{iQ}{2})} \quad (\text{B.10})$$

where $z = e^{i\pi\lambda}$ and u_i are arbitrary. For example, if we take $u_i = -\frac{iQ}{4} - \frac{m_A}{2}$, we find Z_{bif} as defined in the main text with a minus sign for the masses.

In order to compute such a generic abelian integral, we pick poles from the two s_b functions at the numerators: let us focus first on the computation involving the first set of poles, i.e $X_1 = x + M_1 + u_1 = inb + im/b$, belonging to the contour \mathcal{C}_1 , since the computation on the other contours $\mathcal{C}_{i=2, \dots, N_f}$ will be very similar. When $X_1 = x + M_1 + u_1 = inb + im/b$ we find a series made out of

$$\sum_{n,m \geq 0} z^{X_1 - M_1 - u_1} \text{Res}[\overline{s_b}(X_1)] \prod_{j \neq 1} \overline{s_b}(D_{j1} + X_1) \prod_j \underline{s_b}(C_{j1} + X_1) \quad (\text{B.11})$$

which upon evaluation gives

$$\begin{aligned} z^{-M_1 - u_1} \prod_j \left[s_b[D_{j1} + \frac{iQ}{2}] / s_b[C_{j1} - \frac{iQ}{2}] \right] \\ \times \sum_{n \geq 0} \left[\frac{(e^{2\pi b C_{11}})_n (e^{2\pi b C_{21}})_n}{(q)_n (q e^{2\pi b D_{21}})_n} \right] \left[z^{ib} e^{2\pi b \sum_j (u_j + iQ/2)} \right]^n \\ \times \sum_{m \geq 0} \left[\frac{(e^{2\pi C_{11}/b})_m (e^{2\pi C_{21}/b})_m}{(\tilde{q})_m (\tilde{q} e^{2\pi D_{21}/b})_m} \right] \left[z^{i/b} e^{2\pi/b \sum_j (u_j + iQ/2)} \right]^m \end{aligned} \quad (\text{B.12})$$

We defined the quantities,

$$C_{ij} = (M_i - M_j) - (u_i + u_j) \quad D_{ij} = (m_i - m_j) + (u_i - u_j) . \quad (\text{B.13})$$

Here $u_i = -\mu_i$ if we want to compare with \tilde{Z} :

$$\tilde{Z}^{(N_c, N_f)}[\vec{M}, \vec{\mu}] = \prod_{i=1}^{N_c} \prod_{j=1}^{N_f} s_b \left(\frac{iQ}{2} - \mu_j \pm (x_i^{(N_c)} - M_j) \right) \quad (\text{B.14})$$

BC transformations and its real mass deformations. The integral identities (4.27) and (4.38) have been derived in [15] starting from the master relation between multivariate integrals with BC symmetry. The transformation between BC_n and BC_m hyperbolic integrals has been proved by E.Rains in Corollary 4.2 of [8]. For convenience, we repeat here below the main statement. Consider the integral

$$\begin{aligned} \mathcal{I}_n^{(m)}[\vec{\mu}; \omega_1, \omega_2] \\ = \frac{1}{(-4\omega_1\omega_2)^{n/2} n!} \int_{\mathcal{C}^n} \prod_{i=1}^n dx_i \frac{\prod_{i=1}^n \prod_{r=1}^{2m+2n+4} \Gamma_h(\mu_r \pm x_i; \omega_1, \omega_2)}{\prod_{i < j} \Gamma_h(\pm x_i \pm x_j; \omega_1, \omega_2) \prod_{i=1}^n \Gamma_h(\pm 2x_i, \omega_1, \omega_2)} \end{aligned} \quad (\text{B.15})$$

where the contour \mathcal{C} can be closed on the ‘positive’ poles of the form $\mu_r + i\omega_1 + i\omega_2$, excluding the ‘negative’ poles, or viceversa. Equivalently \mathcal{C} is a Barnes contour which agrees with \mathbb{R} . Then,

$$\mathcal{I}_n^{(m)}[\vec{\mu}; \omega_1, \omega_2] = \left(\prod_{s > r \geq 1}^{2m+2n+4} \Gamma_h[\mu_r + \mu_s; \omega_1, \omega_2] \right) \mathcal{I}_m^{(n)}\left[\frac{\omega_1 + \omega_2}{2} - \vec{\mu}; \omega_1, \omega_2\right] \quad (\text{B.16})$$

with the constraint

$$\sum_r \mu_r = (m+1)(\omega_1 + \omega_2) . \tag{B.17}$$

Notice that (B.16) provides an evaluation formula when $m = 0$. Gauge theory parameters N_c and N_f enter with the following dictionary: $N_c = n$ and $N_f = (m + n + 2)$, thus $m = N_f - N_c - 2$. The background parameter b , which measures the squashing of the three-sphere, enters through $\omega_1 = ib$ and $\omega_2 = i/b$, thus $\omega_1 + \omega_2 = iQ$. Finally $\Gamma_h(x) = s_b(\frac{iQ}{2} - x)$.

Summary. In the notation of [15], the equality $\mathcal{Z}_{\mathcal{T}_{\mathfrak{M}}} = \mathcal{Z}_{\mathcal{T}_{\mathfrak{M}'}}$ is obtained from (B.16) by taking the limit

$$\mu_i = m_i + s, \quad \mu_{i+N_f} = \tilde{m}_i - s, \quad s \rightarrow \infty, \quad 1 \leq i \leq N_f \tag{B.18}$$

Then [15] find other two results:

- ★ Derive the monopole duality [section 8 of [15]], which we used in this paper,

$$U(N_c) \oplus N_{\text{flav.}} \text{ and } W = \mathcal{M}^+ \leftrightarrow N_f^2 \oplus 1 \text{ singlets } M_{ij} \oplus \gamma \text{ and } W = \gamma \det M$$

- Recover Aharony duality,

The corresponding integral identities can be deduced from (B.16) as follows,

$$\star \quad t \rightarrow \infty, \quad m_{N_f+1} = \frac{\zeta}{2} + t, \quad \tilde{m}_{N_f+1} = \frac{\zeta}{2} - t, \tag{B.19}$$

$$\text{constraint becomes } \sum_{a=1}^{N_f} (m_a + \tilde{m}_a) + \zeta = iQ(N_f - N_c) \tag{B.20}$$

$$\bullet \quad t \rightarrow \infty, \quad m_{N_f+2} = \frac{\zeta - \lambda}{4} - t, \quad \tilde{m}_{N_f+2} = \frac{\zeta - \lambda}{4} + t, \tag{B.21}$$

$$m_{N_f+1} = \frac{\zeta + \lambda}{4} + t, \quad \tilde{m}_{N_f+1} = \frac{\zeta + \lambda}{4} - t,$$

$$\text{constraint becomes } \sum_{a=1}^{N_f} (m_a + \tilde{m}_a) + \zeta = iQ(N_f - N_c + 1) \tag{B.22}$$

In the next paragraphs we present some important details on contact terms involved in these computation.

Details on (B.18). Starting from (B.16), it is trivial to substitute the m, n dependence with gauge theory parameters N_c and N_f . The strategy of [15] is to rewrite the integrals as

$$\int_{-\infty}^{\infty} d\sigma f(\sigma) = 2 \int_{-s}^{\infty} dx f(x + s) \tag{B.23}$$

and take the limit (B.18) on s with the asymptotics expansion of the s_b ,

$$\lim_{x \rightarrow \pm\infty} s_b(x) = e^{\pm i\pi x^2/2} . \tag{B.24}$$

In terms of N_f , the vector $\vec{\mu}$ has $2N_f$ component, and s enter with different signs, specified in (B.18). Since the integration variables are also shifted by $+s$, it will happen that out of the combinations, $\mu_r \pm x_i$ and $\pm x_i \pm x_j$, which appear in (B.15), some are invariant and the others are shifted twice. For example

$$\mu_{i+N_f} + x_j \rightarrow \tilde{m}_i + x_j \quad \mu_i - x_j \rightarrow m_i - x_j \quad (\text{B.25})$$

Instead $\pm 2x_i \rightarrow \pm 2x_i \pm 2s$.

Taking into account these shifts, and the asymptotics expansion (B.24), we find two (different) prefactor in (B.16), one for the l.h.s. and one for r.h.s. These two prefactors depend on m_i, \tilde{m}_j , the integration variables, and s . In particular there is a divergent part. However, upon imposing the constraint, the dependence on the integration variables drops, and the simplified prefactors cancels each other from r.h.s. to l.h.s. It follows that

$$\mathcal{Z}_{\mathcal{T}_{\text{gr}}} = \mathcal{Z}_{\mathcal{T}_{\text{gr}'}} \quad (\text{B.26})$$

where

$$\mathcal{Z}_{\mathcal{T}_{\text{gr}}} = \frac{1}{N_c!} \int \prod_{i=1}^{N_c} dx_i \frac{\prod_{j=1}^{N_c} \prod_{a=1}^{N_f} s_b\left(\frac{iQ}{2} + x_j - m_a\right) s_b\left(\frac{iQ}{2} - x_j - \tilde{m}_b\right)}{\prod_{i<j}^{N_c} s_b\left(\frac{iQ}{2} \pm (x_i - x_j)\right)} \quad (\text{B.27})$$

and

$$\begin{aligned} \mathcal{Z}_{\mathcal{T}_{\text{gr}'}} &= \frac{1}{(N_f - N_c - 2)!} \prod_{a,b=1}^{N_f} s_b\left(\frac{iQ}{2} - (m_a + \tilde{m}_b)\right) \\ &\times \int \prod_{i=1}^{N_f - N_c - 2} dx_i \frac{\prod_{j=1}^{N_f - N_c - 2} \prod_{a=1}^{N_f} s_b(x_j + m_a) s_b(-x_j + \tilde{m}_b)}{\prod_{i<j}^{N_f - N_c - 2} s_b\left(\frac{iQ}{2} \pm (x_i - x_j)\right)} \end{aligned} \quad (\text{B.28})$$

Details on (B.19). On the electric side, i.e. $\mathcal{Z}_{\mathcal{T}_{\text{gr}}}$ with $N_f + 1$ flavors, we consider the following manipulations on the integrand: split the product over $j = 1, \dots, N_f + 1$ into $1 \leq j \leq N_f$ and the last one, and take the limit (B.19),

$$\begin{aligned} &s_b\left(\frac{iQ}{2} + x_i - m_{N_f+1}\right) s_b\left(\frac{iQ}{2} - x_i - \tilde{m}_{N_f+1}\right) \prod_{j=1}^{N_f} s_b\left(\frac{iQ}{2} + x_i - m_j\right) s_b\left(\frac{iQ}{2} - x_i - \tilde{m}_j\right) \\ &\rightarrow e^{i\pi t(iQ-\zeta)} e^{i\pi(\zeta-iQ)x_i} \prod_{j=1}^{N_f} s_b\left(\frac{iQ}{2} + x_i - m_j\right) s_b\left(\frac{iQ}{2} - x_i - \tilde{m}_j\right) \end{aligned}$$

The total prefactor will be $\prod_{i=1}^{N_c} e^{i\pi t(iQ-\zeta)} e^{i\pi(\zeta-iQ)x_i}$. On the magnetic side, i.e. $\mathcal{Z}_{\mathcal{T}_{\text{gr}'}}$, the same kind of manipulations lead to

$$\begin{aligned} &\prod_{i=1}^{N_f - N_c - 1} s_b(m_{N_f+1} + x_i) s_b(\tilde{m}_{N_f+1} - x_i) \prod_{j=1}^{N_f} s_b(m_j + x_i) s_b(\tilde{m}_j - x_i) \\ &\times \prod_{i=1}^{N_f - N_c - 1} e^{i\pi\zeta(t+x_i)} \prod_{j=1}^{N_f} s_b(m_j + x_i) s_b(\tilde{m}_j - x_i) \end{aligned} \quad (\text{B.29})$$

Additionally, on the magnetic side the prefactors produce extra terms,

$$\frac{\prod_{a,b=1}^{N_f+1} s_b\left(\frac{iQ}{2} - m_a - \tilde{m}_b\right)}{\prod_{a,b=1}^{N_f} s_b\left(\frac{iQ}{2} - m_a - \tilde{m}_b\right)} \rightarrow s_b\left(\frac{iQ}{2} - \eta\right) \prod_{a=1}^{N_f} e^{\frac{i\pi}{2}(m_a - \tilde{m}_a)(m_a + \tilde{m}_a + \zeta - iQ)} e^{i\pi t(iQ - \zeta - m_a - \tilde{m}_a)} \quad (\text{B.30})$$

Comparing the divergences on the electric and magnetic side, we find that they are equal and cancel out due to the constraint, i.e.

$$e^{i\pi N_c t(iQ - \zeta)} = e^{i\pi t \sum_a (iQ - \zeta - m_a - \tilde{m}_a)} e^{i\pi(N_f - N_c - 1)t\zeta} \quad (\text{B.31})$$

We can finally re-introduce the notation

$$m_i = \mu_i - M_i \quad \tilde{m}_i = \mu_i + M_i \quad (\text{B.32})$$

and get the relation used in the main text

$$\begin{aligned} & \int dx^{(N_c)} e^{+i\pi(\zeta - iQ) \sum_{a=1}^{N_c} x_a} Z_{\text{vec}}^{(N_c)} \tilde{Z}^{(N_c, N_f)}[-\vec{M}, \vec{\mu}] \\ &= e^{-i\pi \sum_{a=1}^{N_f} M_a(2\mu_a + \zeta - iQ)} s_b\left(\frac{iQ}{2} - \eta\right) \prod_{a,b=1}^{N_f} s_b\left(\frac{iQ}{2} - \mu_a - \mu_b + M_a - M_b\right) \\ & \times \int dx^{(N_f - N_c - 1)} e^{+i\pi\zeta \sum_{a=1}^{N_f} x_a} Z_{\text{vec}}^{(N_f - N_c - 1)} \tilde{Z}^{(N_f - N_c - 1, N_f)}\left[\vec{M}, \frac{iQ}{2} - \vec{\mu}\right] \end{aligned} \quad (\text{B.33})$$

where

$$\tilde{Z}^{(N_c, N_f)}[\vec{M}, \vec{\mu}] = \prod_{i=1}^{N_c} \prod_{j=1}^{N_f} s_b\left(\frac{iQ}{2} - \mu_j \pm (x_i^{(N_c)} - M_j)\right) \quad (\text{B.34})$$

Details on (B.21). On the electric side, i.e. $\mathcal{Z}_{\mathcal{T}_{\text{el}}}$ with $N_f + 2$ flavors, we single out the two extra flavors and take the limit, thus producing

$$\begin{aligned} & \prod_{a=1}^2 s_b\left(\frac{iQ}{2} + x_i - m_{N_f+a}\right) s_b\left(\frac{iQ}{2} - x_i - \tilde{m}_{N_f+a}\right) \\ & \times \prod_{j=1}^{N_f} s_b\left(\frac{iQ}{2} + x_i - m_j\right) s_b\left(\frac{iQ}{2} - x_i - \tilde{m}_j\right) \\ & \rightarrow e^{i\pi t(2iQ - \zeta)} e^{i\pi\lambda x_i} \prod_{j=1}^{N_f} s_b\left(\frac{iQ}{2} + x_i - m_j\right) s_b\left(\frac{iQ}{2} - x_i - \tilde{m}_j\right) \end{aligned} \quad (\text{B.35})$$

Then, the total prefactor is $\prod_{i=1}^{N_c} e^{i\pi t(2iQ - \zeta)} e^{i\pi\lambda x_i}$. Similarly on the magnetic side,

$$\begin{aligned} & \prod_{i=1}^{N_f - N_c} \prod_{a=1}^2 s_b(m_{N_f+a} + x_i) s_b(\tilde{m}_{N_f+a} - x_i) \prod_{j=1}^{N_f} s_b(m_j + x_i) s_b(\tilde{m}_j - x_i) \\ & \times \prod_{i=1}^{N_f - N_c} e^{i\pi(\zeta t + \lambda x_i)} \prod_{j=1}^{N_f} s_b(m_j + x_i) s_b(\tilde{m}_j - x_i) \end{aligned} \quad (\text{B.36})$$

and the extra prefactors,

$$\frac{\prod_{a,b=1}^{N_f+2} s_b \left(\frac{iQ}{2} - m_a - \tilde{m}_b \right)}{\prod_{a,b=1}^{N_f} s_b \left(\frac{iQ}{2} - m_a - \tilde{m}_b \right)} \tag{B.37}$$

$$\rightarrow e^{2i\pi t(iQ-\zeta)} s_b \left(\frac{iQ - \zeta \pm \lambda}{2} \right) \prod_{a=1}^{N_f} e^{\frac{i\pi}{2}\lambda(m_a - \tilde{m}_a) + i\pi(2iQ - \zeta - 2m_a - 2\tilde{m}_a)t}$$

By using the constraint, the divercences cancel each other, i.e

$$e^{i\pi N_c t(2iQ-\zeta)} = e^{i\pi(N_f-N_c)\zeta t} e^{2i\pi t(iQ-\zeta)} e^{i\pi \sum_a (2iQ-\zeta-2m_a-2\tilde{m}_a)t} \tag{B.38}$$

We can finally re-introduce the notation

$$m_i = \mu_i - M_i \quad \tilde{m}_i = \mu_i + M_i \tag{B.39}$$

The result is

$$\int dx^{(N_c)} e^{i\pi\lambda \sum_{a=1}^{N_c} x_i^{(N_c)}} Z_{\text{vec}}^{(N_c)} \tilde{Z}^{(N_c, N_f)}[-\vec{M}, \vec{\mu}] \tag{B.40}$$

$$= s_b \left(\frac{iQ - \zeta \pm \lambda}{2} \right) \prod_{a,b=1}^{N_f} s_b \left(\frac{iQ}{2} - \mu_a - \mu_b + M_a - M_b \right)$$

$$\times e^{-i\pi\lambda \sum_{a=1}^{N_f} M_a} \int dx^{(N_f-N_c)} e^{i\pi\lambda \sum_{a=1}^{N_f-N_c} x_i^{(N_f-N_c)}} Z_{\text{vec}}^{(N_f-N_c)} \tilde{Z}^{(N_f-N_c, N_f)} \left[\vec{M}, \frac{iQ}{2} - \vec{\mu} \right]$$

C Holomorphic blocks calculations for \mathcal{T} and \mathcal{T}'

In this section we evaluate the holomorphic blocks for \mathcal{T} and \mathcal{T}' over the reference contours.

We first list the integrals obtained via factorisation of the S_b^3 partition function, which is a consequence of the factorisation property of the double sine (B.2).

For theory \mathcal{T} we have

$$\Upsilon_{\mathcal{T}} = \mathcal{E}_{\mathcal{T}} \mathcal{F}_{\mathcal{T}} \left[z^{(1)} \right]^{-\frac{i\xi}{b} - \beta \frac{1+N}{2}} \frac{\left(\frac{t \mu_i}{z} \right)_{\infty}}{\left(\frac{\mu_i}{z} \right)_{\infty}} \tag{C.1}$$

where

$$\mathcal{F}_{\mathcal{T}} = \frac{(q)_{\infty}}{(t)_{\infty}^N} \prod_{i>j}^{N+1} \frac{\left(\frac{q \mu_i}{t \mu_j} \right)_{\infty}}{\left(\frac{t \mu_i}{\mu_j} \right)_{\infty}} \tag{C.2}$$

is the contribution of the flipping fields and $\mathcal{E}_{\mathcal{T}}$ is a contact term. We have also introduced the exponentiated variables $\mu_i = e^{2\pi b M_i}$ and $q = e^{2\pi i b^2}$, $t = q^{\beta}$.

On the dual side, for theory \mathcal{T}' we have:

$$\Upsilon_{\mathcal{T}'} = \mathcal{E}_{\mathcal{T}'} \mathcal{F}_{\mathcal{T}'} \prod_{a=1}^N \prod_{i=1}^a \left[z_i^{(a)} \right]^{-i \frac{M_a - M_{a+1}}{b} - \beta} B_{\text{tail}} \prod_{i=1}^N \frac{\left(\frac{t e^{2\pi b \xi}}{z_i^{(N)}} \right)_{\infty}}{\left(\frac{e^{2\pi b \xi}}{z_i^{(N)}} \right)_{\infty}} \frac{\left(\frac{t^{(1+N)/2}}{z_i^{(N)}} \right)_{\infty}}{\left(\frac{t^{(1-N)/2}}{z_i^{(N)}} \right)_{\infty}} \tag{C.3}$$

with

$$B_{\text{tail}} = \frac{(q)_\infty^{\frac{N(N+1)}{2}}}{(t)_\infty^{\frac{N(N+1)}{2}}} \prod_{a=1}^N \prod_{i=1}^a \prod_{k=1 \& k \neq i}^a \frac{\left(\frac{z_k^{(a)}}{z_i^{(a)}}\right)_\infty}{\left(t \frac{z_k^{(a)}}{z_i^{(a)}}\right)_\infty} \prod_{a=1}^{N-1} \prod_{i=1}^a \prod_{j=1}^{a+1} \frac{\left(t \frac{z_j^{(a+1)}}{z_i^{(a)}}\right)_\infty}{\left(\frac{z_j^{(a+1)}}{z_i^{(a)}}\right)_\infty} \quad (\text{C.4})$$

and

$$\mathcal{F}_{\mathcal{T}'} = \frac{\left(qt^{-\frac{N+1}{2}} e^{-2\pi b\xi}; q\right)_\infty}{\left(t^{\frac{1+N}{2}} e^{-2\pi b\xi}; q\right)_\infty} \prod_{l=1}^{N-1} \frac{1}{(t^{l+1})_\infty}. \quad (\text{C.5})$$

The factorization procedure gives rather complicated expressions for the contact terms $\mathcal{E}_{\mathcal{T}}$ and $\mathcal{E}_{\mathcal{T}'}$. However, all we need to check the spectral duality is the *ratio* of the contact terms which is comparatively easy to write down:

$$\frac{\mathcal{E}_{\mathcal{T}'}}{\mathcal{E}_{\mathcal{T}}} = R e^{2\pi b(-i\xi/bM_{N+1} + (\beta(N+1)-1)\xi - \frac{1}{2}\beta \sum_{k=1}^{N+1} (2k-N-1)M_k + (2\beta-1) \sum_{k=1}^{N+1} (2k-N-2)M_k)} \quad (\text{C.6})$$

where $R = R(N, b, \beta)$ is a prefactor which we henceforth discard.

We would like to evaluate the block integrals, i.e. integrals of $\Upsilon_{\mathcal{T}}$ and $\Upsilon_{\mathcal{T}'}$ on the reference contours, which for both theories we denote by Γ_{α_0} .

Let's start with the theory \mathcal{T} . We focus on the part of $\Upsilon_{\mathcal{T}}$ which does depend on the integration variables and take as the reference contour Γ_{α_0} as the contour $\mathcal{C}_{1,0,\dots,0}$ encircling the poles at $z^{(1)} = \mu_1 q^k$, $k \in \mathbb{Z}_{\geq 1}$. We find:

$$\begin{aligned} \mathcal{I}_{\mathcal{T}}^{\alpha_0}(\vec{\mu}, \vec{\tau}, q, t) &= \oint_{\mathcal{C}_{1,0,\dots,0}} \frac{dz^{(1)}}{z^{(1)}} \left(z^{(1)}\right)^{-\frac{i\xi}{b} - \beta \frac{N+1}{2}} \prod_{i=1}^{N+1} \frac{\left(t \frac{\mu_i}{z^{(1)}}; q\right)_\infty}{\left(\frac{\mu_i}{z^{(1)}}; q\right)_\infty} \\ &= \mathcal{I}_{0,\mathcal{T}}^{\alpha_0}(\vec{\mu}, \vec{\tau}, q, t) Z_{\text{vort},\mathcal{T}}^{\alpha_0}(\vec{\mu}, \vec{\tau}, q, t), \end{aligned} \quad (\text{C.7})$$

where factored out the contribution of the *first* pole at $z^{(1)} = \mu_1$:

$$\mathcal{I}_{0,\mathcal{T}}^{\alpha_0}(\vec{\mu}, \xi, q, t) = \text{Res}_{z^{(1)}=\mu_1} \left(z^{(1)}\right)^{-\frac{i\xi}{b} - \beta \frac{N+1}{2} - 1} \prod_{i=1}^{N+1} \frac{\left(t \frac{\mu_i}{z^{(1)}}; q\right)_\infty}{\left(\frac{\mu_i}{z^{(1)}}; q\right)_\infty} \quad (\text{C.8})$$

$$= \frac{(t; q)_\infty}{(q; q)_\infty} e^{-2\pi i b M_1 \xi - \pi b \beta (N+1) M_1} \prod_{i=2}^{N+1} \frac{\left(t \frac{\mu_i}{\mu_1}; q\right)_\infty}{\left(\frac{\mu_i}{\mu_1}; q\right)_\infty}, \quad (\text{C.9})$$

and the vortex series

$$Z_{\text{vort},\mathcal{T}}^{\alpha_0}(\vec{\mu}, \xi, q, t) = \sum_{k \geq 0} \left(t^{\frac{N+1}{2}} e^{2\pi b\xi}\right)^k \prod_{i=1}^{N+1} \frac{\left(\frac{q\mu_i}{t\mu_i}; q\right)_k}{\left(q \frac{\mu_i}{\mu_i}; q\right)_k}. \quad (\text{C.10})$$

Taking into account also the contribution of the flipping fields $\mathcal{F}_{\mathcal{T}}$ we have:

$$Z_{\text{cl},\mathcal{T}}^{\alpha_0} Z_{1\text{-loop},\mathcal{T}}^{\alpha_0} \equiv \mathcal{F}_{\mathcal{T}} \mathcal{I}_{0,\mathcal{T}}^{\alpha_0}(\vec{\mu}, \xi, q, t). \quad (\text{C.11})$$

For the dual theory we argue that the reference contour Γ_{α_0} is described iteratively as a sequence of contours $\{\mathcal{C}_{1,0}, \mathcal{C}_{1,1}, \mathcal{C}_{1,2}, \dots, \mathcal{C}_{1,N-1}\}$:

$$\begin{aligned}
 \mathcal{I}_{\mathcal{T}'}^{\alpha_0} &= \oint_{\mathcal{C}_{1,0}} dz_1^{(1)} \oint_{\mathcal{C}_{1,1}} d^2 z^{(2)} \oint_{\mathcal{C}_{1,2}} d^3 z^{(3)} \dots \oint_{\mathcal{C}_{1,N-1}} d^N z^{(N)} \prod_{a=1}^N \prod_{i=1}^a \left(z_i^{(a)} \right)^{-i \frac{M_a - M_{a+1} - \beta - 1}{b}} \\
 &\times \left\{ \prod_{a=2}^N \prod_{i \neq j}^a \frac{\left(\frac{z_i^{(a)}}{z_j^{(a)}}; q \right)_{\infty}}{\left(t \frac{z_i^{(a)}}{z_j^{(a)}}; q \right)_{\infty}} \right\} \left\{ \prod_{a=1}^{N-1} \prod_{i=1}^a \prod_{j=1}^{a+1} \frac{\left(t \frac{z_j^{(a+1)}}{z_i^{(a)}}; q \right)_{\infty}}{\left(\frac{z_j^{(a+1)}}{z_i^{(a)}}; q \right)_{\infty}} \right\} \\
 &\times \left\{ \prod_{i=1}^N \frac{\left(t \frac{e^{2\pi b \xi}}{z_i^{(N)}}; q \right)_{\infty}}{\left(\frac{e^{2\pi b \xi}}{z_i^{(N)}}; q \right)_{\infty}} \frac{\left(t^{\frac{1+N}{2}}; q \right)_{\infty}}{\left(z_i^{(N)}; q \right)_{\infty}} \right\}. \tag{C.12}
 \end{aligned}$$

The pole structure is complicated: at each “level” a of integration (a running from 1 to N) corresponding to the gauge group $U(a)$ the poles split into two groups encoded by two Young diagrams ${}^{(a)}Y^{(1)}$ and ${}^{(a)}Y^{(2)}$. The first group consists of one variable $z_1^{(a)} = e^{2\pi b \xi} q^{({}^{(a)}Y_1^{(1)})}$, while the second one has $(a-1)$ variables $z_i^{(a)} = t^{\frac{1-N}{2}} q^{({}^{(a)}Y_{i-1}^{(2)})} t^{a-i}$, $i = 2, \dots, a$. Similarly to the previous section we have the decomposition:

$$\mathcal{I}_{\mathcal{T}'}^{\alpha_0}(\vec{\mu}, \xi, q, t) = \mathcal{I}_{0, \mathcal{T}'}^{\alpha_0}(\vec{\mu}, \xi, q, t) Z_{\text{vort}, \mathcal{T}'}^{\alpha_0}(\vec{\mu}, \xi, q, t), \tag{C.13}$$

with

$$\begin{aligned}
 \mathcal{I}_{0, \mathcal{T}'}^{\alpha_0}(\vec{\mu}, \xi, q, t) &= \text{Res}_{\substack{z_1^{(a)} = e^{2\pi b \xi} \\ z_i^{(a)} = t^{\frac{1-N}{2} + a - i}, i=2, \dots, a}} \{ \text{integrand} \} \\
 &= e^{\pi i b^2 \beta^2 \frac{N(N^2-1)}{6} + \pi b \beta (N+1) M_1 + \pi b \beta \sum_{a=1}^{N+1} (2a-3-N) M_a - 2\pi i \xi (M_1 - M_{N+1} - i b \beta N)} \\
 &\times \prod_{i=1}^N \frac{(t^i; q)_{\infty}}{(t; q)_{\infty}} \frac{\left(t^{\frac{N+1}{2}} e^{-2\pi b \xi}; q \right)_{\infty}}{\left(t^{\frac{1-N}{2}} e^{-2\pi b \xi}; q \right)_{\infty}}. \tag{C.14}
 \end{aligned}$$

One can also write down the vortex series explicitly as a sum over a set of Young diagrams ${}^{(a)}Y^1$ and ${}^{(a)}Y^2$, but it is probably easier and definitely more compact to notice that the integral (C.12) can be obtained from that of $T[\text{SU}(N+1)]$ theory given in eq. (2.16) of [25]. Indeed, if we set the $T[\text{SU}(N+1)]$ mass parameters $\tau_1^{T[\text{SU}(N+1)]} = e^{2\pi b \xi}$, $\tau_a^{T[\text{SU}(N+1)]} = t^{a-2} t^{\frac{1-N}{2}}$ for $a = 2, \dots, (N+1)$ we obtain precisely the integral representation (C.12), and even the contour of integration (the sequence $\mathcal{C}_{1,0}, \mathcal{C}_{1,1}$ etc.) is neatly matched. We thus

have

$$Z_{\text{vort}, \mathcal{T}'}^{\alpha_0}(\vec{\mu}, \xi, q, t) = \sum_{k_i^a} \prod_{a=1}^N \left[\left(t \frac{\mu_a}{\mu_{a+1}} \right)^{\sum_{i=1}^a k_i^{(a)}} \prod_{i \neq j}^a \frac{\left(t \frac{\tau_i}{\tau_j}; q \right)_{k_i^{(a)} - k_j^{(a)}}{\left(\frac{\tau_i}{\tau_j}; q \right)_{k_i^{(a)} - k_j^{(a)}}} \right. \\
 \left. \times \prod_{i=1}^a \prod_{j=1}^{a+1} \frac{\left(\frac{q}{t} \frac{\tau_i}{\tau_j}; q \right)_{k_i^{(a)} - k_j^{(a+1)}}{\left(q \frac{\tau_i}{\tau_j}; q \right)_{k_i^{(a)} - k_j^{(a+1)}}} \right]_{\substack{\tau_1 = e^{2\pi b \xi}, \\ \tau_i = t^{i-2} t^{\frac{1-N}{2}}, i \geq 2}} \quad (\text{C.15})$$

where $k_i^{(a)}$ satisfy

$$\begin{aligned}
 k_1^{(1)} &\geq k_1^{(2)} \geq k_1^{(3)} \geq \dots \geq k_1^{(N)} \geq 0 \\
 k_2^{(2)} &\geq k_2^{(3)} \geq \dots \geq k_2^{(N)} \geq 0 \\
 k_3^{(3)} &\geq \dots \geq k_3^{(N)} \geq 0 \\
 &\vdots \\
 & k_N^{(N)} \geq 0
 \end{aligned} \quad (\text{C.16})$$

The integers $k_i^{(a)}$ are of course just another way of writing the sequence of Young diagrams ${}^{(a)}Y^1$ and ${}^{(a)}Y^2$. And as before we define:

$$Z_{\text{cl}, \mathcal{T}'}^{\alpha_0} Z_{1\text{-loop}, \mathcal{T}'}^{\alpha_0} = \mathcal{F}_{\mathcal{T}'} \mathcal{I}_{0, \mathcal{T}'}^{\alpha_0}(\vec{\mu}, \xi, q, t). \quad (\text{C.17})$$

D Fiber-base invariance and Higgsing

In this appendix we check the equality of topological string partitions, for fiber-base dual pairs, after Higgsing, and for the first nontrivial case of $N = 2$. We write down the first terms of the vortex series and then expand the partition functions in a double expansion in masses and FI parameters to check the equality (5.31) for the first few orders.

For the topological string on CY \mathcal{Y}) we have following eqs. (5.28) and (C.10)

$$Z_{1\text{-loop}, \text{top}}^{\mathcal{Y}} Z_{\text{vort}, \text{top}}^{\mathcal{Y}} = \frac{\left(\frac{q}{t} \frac{\mu_2}{\mu_3}; q \right)_{\infty} \left(q \frac{\mu_1}{\mu_2}; q \right)_{\infty} \left(q \frac{\mu_1}{\mu_3}; q \right)_{\infty}}{\left(t \frac{\mu_2}{\mu_3}; q \right)_{\infty} \left(t \frac{\mu_1}{\mu_2}; q \right)_{\infty} \left(t \frac{\mu_1}{\mu_3}; q \right)_{\infty}} \quad (\text{D.1}) \\
 \times \left[1 + t^N \frac{\tau_1}{\tau_2} \frac{(1-q)}{(1-q)} \frac{(1 - \frac{q}{t})}{(1 - q \frac{\mu_1}{\mu_2})} \frac{(1 - \frac{q}{t} \frac{\mu_1}{\mu_3})}{(1 - q \frac{\mu_1}{\mu_3})} + \mathcal{O} \left(\left(\frac{\tau_1}{\tau_2} \right)^2 \right) \right].$$

On the dual side we have (see eqs. (5.30) and (C.15))

$$Z_{1\text{-loop}, \text{top}}^{\mathcal{Y}'} Z_{\text{vort}, \text{top}}^{\mathcal{Y}'} = \frac{\left(q \frac{\tau_1}{\tau_2}; q \right)_{\infty}}{\left(t \frac{\tau_1}{\tau_2}; q \right)_{\infty}} \left[1 + t \frac{\mu_1}{\mu_2} \frac{(1 - \frac{q}{t})}{(1 - q)} \frac{(1 - \frac{q}{t} \frac{\tau_1}{\tau_2})}{(1 - q \frac{\tau_1}{\tau_2})} + t \frac{\mu_2}{\mu_3} \frac{(1 - \frac{q}{t^2})}{(1 - q)} \right. \\
 \left. + t^2 \frac{\mu_1}{\mu_3} \frac{(1 - \frac{q}{t})}{(1 - q)^2} \frac{(1 - \frac{q}{t^2})}{(1 - \frac{\tau_1}{\tau_2})} \frac{(1 - \frac{\tau_1}{t \tau_2})}{(1 - \frac{\tau_1}{\tau_2})} + \mathcal{O} \left(\left(\frac{\mu_a}{\mu_{a+1}} \right)^2 \right) \right] \quad (\text{D.2})$$

Expanding eqs. (D.1) and (D.2) to first order in $\frac{\tau_1}{\tau_2}$, $\frac{\mu_1}{\mu_2}$ and $\frac{\mu_2}{\mu_3}$ we get

$$\begin{aligned}
 Z_{1\text{-loop,top}}^{\mathcal{Y}} Z_{\text{vort,top}}^{\mathcal{Y}} &= 1 + \frac{\mu_1(t+1)\tau_1(q^2t - q^2 + q - t^2)(q-t)^2}{\mu_3(q-1)^3t^2\tau_2} \\
 &\quad + \frac{\mu_1\tau_1(q^2t - q^2 + q - t^2)(q-t)}{\mu_2(q-1)^2t\tau_2} + \frac{\mu_2\tau_1(q-t^2)(q-t)}{\mu_3(q-1)^2t\tau_2} \\
 &\quad + \frac{\mu_2(q-t^2)}{\mu_3(q-1)t} + \frac{\mu_1(t+1)(q-t)^2}{\mu_3(q-1)^2t} + \frac{\mu_1(q-t)}{\mu_2(q-1)} + \frac{\tau_1(q-t)}{(q-1)\tau_2} \\
 &\quad + \mathcal{O}\left(\left(\frac{\mu_a}{\mu_{a+1}}\right)^2, \left(\frac{\tau_1}{\tau_2}\right)^2\right) \\
 &= Z_{1\text{-loop,top}}^{\mathcal{Y}'} Z_{\text{vort,top}}^{\mathcal{Y}'}. \tag{D.3}
 \end{aligned}$$

The equality (5.31) can be checked to higher orders quite easily on a computer and turns out to be valid.

Open Access. This article is distributed under the terms of the Creative Commons Attribution License (CC-BY 4.0), which permits any use, distribution and reproduction in any medium, provided the original author(s) and source are credited.

References

- [1] V. Pestun et al., *Localization techniques in quantum field theories*, *J. Phys. A* **50** (2017) 440301 [[arXiv:1608.02952](#)] [[INSPIRE](#)].
- [2] O. Aharony, S.S. Razamat, N. Seiberg and B. Willett, *3d dualities from 4d dualities*, *JHEP* **07** (2013) 149 [[arXiv:1305.3924](#)] [[INSPIRE](#)].
- [3] S. Benvenuti, *A tale of exceptional 3d dualities*, *JHEP* **03** (2019) 125 [[arXiv:1809.03925](#)] [[INSPIRE](#)].
- [4] A. Amariti and L. Cassia, *USp(2N_c) SQCD₃ with antisymmetric: dualities and symmetry enhancements*, *JHEP* **02** (2019) 013 [[arXiv:1809.03796](#)] [[INSPIRE](#)].
- [5] D. Gaiotto and E. Witten, *S-duality of boundary conditions in N = 4 super Yang-Mills theory*, *Adv. Theor. Math. Phys.* **13** (2009) 721 [[arXiv:0807.3720](#)] [[INSPIRE](#)].
- [6] O. Aharony, *IR duality in d = 3 N = 2 supersymmetric USp(2N_c) and U(N_c) gauge theories*, *Phys. Lett. B* **404** (1997) 71 [[hep-th/9703215](#)] [[INSPIRE](#)].
- [7] V.P. Spiridonov and G.S. Vartanov, *Elliptic hypergeometry of supersymmetric dualities*, *Commun. Math. Phys.* **304** (2011) 797 [[arXiv:0910.5944](#)] [[INSPIRE](#)].
- [8] E.M. Rains, *Limits of elliptic hypergeometric integrals*, *Ramanujan J.* **18** (2007) 257 [[math/0607093](#)].
- [9] E.M. Rains, *Transformations of elliptic hypergeometric integrals*, *Ann. Math.* **172** (2010) 169.
- [10] F.J. van de Bult, *Hyperbolic hypergeometric functions*, *Ph.D. thesis*, University of Amsterdam, Amsterdam, The Netherlands (2007).
- [11] M. Bullimore, H.-C. Kim and P. Koroteev, *Defects and quantum Seiberg-Witten geometry*, *JHEP* **05** (2015) 095 [[arXiv:1412.6081](#)] [[INSPIRE](#)].

- [12] S. Benvenuti and S. Giacomelli, *Abelianization and sequential confinement in 2 + 1 dimensions*, *JHEP* **10** (2017) 173 [[arXiv:1706.04949](#)] [[INSPIRE](#)].
- [13] S. Giacomelli and N. Mekareeya, *Mirror theories of 3d $\mathcal{N} = 2$ SQCD*, *JHEP* **03** (2018) 126 [[arXiv:1711.11525](#)] [[INSPIRE](#)].
- [14] A. Collinucci, S. Giacomelli, R. Savelli and R. Valandro, *T-branes through 3d mirror symmetry*, *JHEP* **07** (2016) 093 [[arXiv:1603.00062](#)] [[INSPIRE](#)].
- [15] F. Benini, S. Benvenuti and S. Pasquetti, *SUSY monopole potentials in 2 + 1 dimensions*, *JHEP* **08** (2017) 086 [[arXiv:1703.08460](#)] [[INSPIRE](#)].
- [16] A. Hanany and D. Tong, *Vortex strings and four-dimensional gauge dynamics*, *JHEP* **04** (2004) 066 [[hep-th/0403158](#)] [[INSPIRE](#)].
- [17] D. Gaiotto, L. Rastelli and S.S. Razamat, *Bootstrapping the superconformal index with surface defects*, *JHEP* **01** (2013) 022 [[arXiv:1207.3577](#)] [[INSPIRE](#)].
- [18] A. Mironov and A. Morozov, *The power of Nekrasov functions*, *Phys. Lett. B* **680** (2009) 188 [[arXiv:0908.2190](#)] [[INSPIRE](#)].
- [19] C. Kozcaz, S. Pasquetti and N. Wyllard, *A & B model approaches to surface operators and Toda theories*, *JHEP* **08** (2010) 042 [[arXiv:1004.2025](#)] [[INSPIRE](#)].
- [20] T. Dimofte, S. Gukov and L. Hollands, *Vortex counting and Lagrangian 3-manifolds*, *Lett. Math. Phys.* **98** (2011) 225 [[arXiv:1006.0977](#)] [[INSPIRE](#)].
- [21] N. Dorey, S. Lee and T.J. Hollowood, *Quantization of integrable systems and a 2d/4d duality*, *JHEP* **10** (2011) 077 [[arXiv:1103.5726](#)] [[INSPIRE](#)].
- [22] F. Nieri, S. Pasquetti, F. Passerini and A. Torrielli, *5D partition functions, q-Virasoro systems and integrable spin-chains*, *JHEP* **12** (2014) 040 [[arXiv:1312.1294](#)] [[INSPIRE](#)].
- [23] D. Gaiotto and H.-C. Kim, *Surface defects and instanton partition functions*, *JHEP* **10** (2016) 012 [[arXiv:1412.2781](#)] [[INSPIRE](#)].
- [24] F. Nieri, Y. Pan and M. Zabzine, *3d mirror symmetry from S-duality*, *Phys. Rev. D* **98** (2018) 126002 [[arXiv:1809.00736](#)] [[INSPIRE](#)].
- [25] A. Nedelin, S. Pasquetti and Y. Zenkevich, *T[SU(N)] duality webs: mirror symmetry, spectral duality and gauge/CFT correspondences*, *JHEP* **02** (2019) 176 [[arXiv:1712.08140](#)] [[INSPIRE](#)].
- [26] D. Tong, *Dynamics of $N = 2$ supersymmetric Chern-Simons theories*, *JHEP* **07** (2000) 019 [[hep-th/0005186](#)] [[INSPIRE](#)].
- [27] D.L. Jafferis, *The exact superconformal R-symmetry extremizes Z*, *JHEP* **05** (2012) 159 [[arXiv:1012.3210](#)] [[INSPIRE](#)].
- [28] S. Cabrera and A. Hanany, *Branes and the Kraft-Procesi transition*, *JHEP* **11** (2016) 175 [[arXiv:1609.07798](#)] [[INSPIRE](#)].
- [29] V. Borokhov, A. Kapustin and X.-k. Wu, *Monopole operators and mirror symmetry in three-dimensions*, *JHEP* **12** (2002) 044 [[hep-th/0207074](#)] [[INSPIRE](#)].
- [30] F. Benini, C. Closset and S. Cremonesi, *Quantum moduli space of Chern-Simons quivers, wrapped D6-branes and AdS₄/CFT₃*, *JHEP* **09** (2011) 005 [[arXiv:1105.2299](#)] [[INSPIRE](#)].
- [31] S. Benvenuti and S. Giacomelli, *Supersymmetric gauge theories with decoupled operators and chiral ring stability*, *Phys. Rev. Lett.* **119** (2017) 251601 [[arXiv:1706.02225](#)] [[INSPIRE](#)].

- [32] A. Hanany and E. Witten, *Type IIB superstrings, BPS monopoles and three-dimensional gauge dynamics*, *Nucl. Phys. B* **492** (1997) 152 [[hep-th/9611230](#)] [[INSPIRE](#)].
- [33] D. Gaiotto and P. Koroteev, *On three dimensional quiver gauge theories and integrability*, *JHEP* **05** (2013) 126 [[arXiv:1304.0779](#)] [[INSPIRE](#)].
- [34] P. Agarwal, I. Bah, K. Maruyoshi and J. Song, *Quiver tails and $\mathcal{N} = 1$ SCFTs from M5-branes*, *JHEP* **03** (2015) 049 [[arXiv:1409.1908](#)] [[INSPIRE](#)].
- [35] A. Kapustin and M.J. Strassler, *On mirror symmetry in three-dimensional Abelian gauge theories*, *JHEP* **04** (1999) 021 [[hep-th/9902033](#)] [[INSPIRE](#)].
- [36] S. Benvenuti and S. Pasquetti, *3d $\mathcal{N} = 2$ mirror symmetry, pq-webs and monopole superpotentials*, *JHEP* **08** (2016) 136 [[arXiv:1605.02675](#)] [[INSPIRE](#)].
- [37] N. Hama, K. Hosomichi and S. Lee, *SUSY gauge theories on squashed three-spheres*, *JHEP* **05** (2011) 014 [[arXiv:1102.4716](#)] [[INSPIRE](#)].
- [38] C. Closset et al., *Contact terms, unitarity and F-maximization in three-dimensional superconformal theories*, *JHEP* **10** (2012) 053 [[arXiv:1205.4142](#)] [[INSPIRE](#)].
- [39] C. Closset et al., *Comments on Chern-Simons contact terms in three dimensions*, *JHEP* **09** (2012) 091 [[arXiv:1206.5218](#)] [[INSPIRE](#)].
- [40] C. Closset, H. Kim and B. Willett, *Seifert fibering operators in 3d $\mathcal{N} = 2$ theories*, *JHEP* **11** (2018) 004 [[arXiv:1807.02328](#)] [[INSPIRE](#)].
- [41] S. Pasquetti, *Factorisation of $N = 2$ theories on the squashed 3-sphere*, *JHEP* **04** (2012) 120 [[arXiv:1111.6905](#)] [[INSPIRE](#)].
- [42] C. Beem, T. Dimofte and S. Pasquetti, *Holomorphic blocks in three dimensions*, *JHEP* **12** (2014) 177 [[arXiv:1211.1986](#)] [[INSPIRE](#)].
- [43] S. Pasquetti, *Holomorphic blocks and the 5d AGT correspondence*, *J. Phys. A* **50** (2017) 443016 [[arXiv:1608.02968](#)] [[INSPIRE](#)].
- [44] G. Gasper and M. Rahman, *Basic hypergeometric series*, Encyclopedia of Mathematics and its Applications, Cambridge U.K. (1990).
- [45] F. Nieri and S. Pasquetti, *Factorisation and holomorphic blocks in 4d*, *JHEP* **11** (2015) 155 [[arXiv:1507.00261](#)] [[INSPIRE](#)].
- [46] A. Giveon and D. Kutasov, *Brane dynamics and gauge theory*, *Rev. Mod. Phys.* **71** (1999) 983 [[hep-th/9802067](#)] [[INSPIRE](#)].
- [47] A. Iqbal, C. Kozcaz and C. Vafa, *The refined topological vertex*, *JHEP* **10** (2009) 069 [[hep-th/0701156](#)] [[INSPIRE](#)].
- [48] H. Awata, B. Feigin and J. Shiraishi, *Quantum algebraic approach to refined topological vertex*, *JHEP* **03** (2012) 041 [[arXiv:1112.6074](#)] [[INSPIRE](#)].
- [49] A. Mironov, A. Morozov and Y. Zenkevich, *Ding-Iohara-Miki symmetry of network matrix models*, *Phys. Lett. B* **762** (2016) 196 [[arXiv:1603.05467](#)] [[INSPIRE](#)].
- [50] H. Awata et al., *Explicit examples of DIM constraints for network matrix models*, *JHEP* **07** (2016) 103 [[arXiv:1604.08366](#)] [[INSPIRE](#)].
- [51] M. Taki, *Refined topological vertex and instanton counting*, *JHEP* **03** (2008) 048 [[arXiv:0710.1776](#)] [[INSPIRE](#)].