

PROFE



**US Army Corps
of Engineers**

**REPAIR, EVALUATION, MAINTENANCE
REHABILITATION RESEARCH PROG**

TECHNICAL REPORT REMR-HY-2

**FLOATING DEBRIS CONTROL;
A LITERATURE REVIEW**

by

Roscoe E. Perham

DEPARTMENT OF THE ARMY
US Army Cold Regions Research and Engineering Laboratory
72 Lyme Road
Hanover, New Hampshire 03755-1290

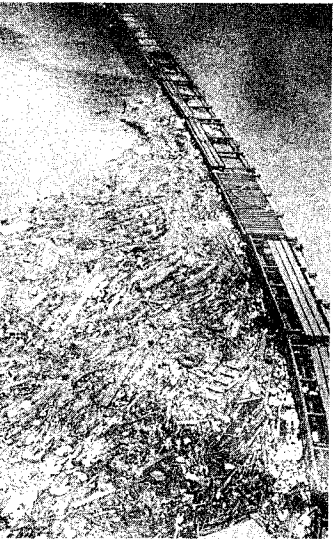
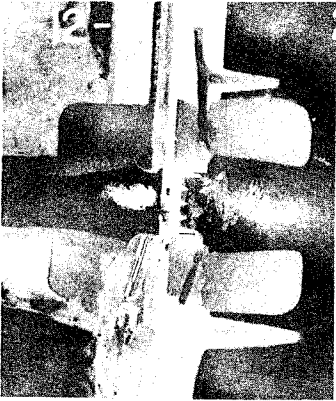

June 1987

Final Report

Approved For Public Release, Distribution Unlimited

Prepared for **DEPARTMENT OF THE ARMY**
US Army Corps of Engineers
Washington, DC 20314-1000

Under **Civil Works Research Work Unit 32320**

Monitored by **Structures Laboratory**
US Army Engineer Waterways Experiment Station
PO Box 631, Vicksburg, Mississippi 39180-0631



The following two letters used as part of the number designating technical reports of research published under the Repair, Evaluation, Maintenance, and Rehabilitation (REMR) Research Program identify the problem area under which the report was prepared:

| Problem Area | | Problem Area | |
|--------------|-------------------------------|--------------|---------------------------|
| CS | Concrete and Steel Structures | EM | Electrical and Mechanical |
| GT | Geotechnical | EI | Environmental Impacts |
| HY | Hydraulics | OM | Operations Management |
| CO | Coastal | | |

For example, Technical Report REMR-HY-2 is the second report published under the Concrete and Steel Structures problem area.

Destroy this report when no longer needed. Do not return it to the originator.

The findings in this report are not to be construed as an official Department of the Army position unless so designated by other authorized documents.

The contents of this report are not to be used for advertising, publication, or promotional purposes. Citation of trade names does not constitute an official endorsement or approval of the use of such commercial products.

COVER PHOTOS:

TOP—Aerial view of floating debris, mostly whole trees, at an Alaskan flood control dam. Central gate is blocked partly open causing some downstream scour. Water flows right to left.

BOTTOM—Debris diversion boom and debris, Appalachian Power Company Station at Winfield Lock and Dam, Kanawha River, West Virginia.

Unclassified

SECURITY CLASSIFICATION OF THIS PAGE

| REPORT DOCUMENTATION PAGE | | | | Form Approved OMB No 0704-0188 Exp Date Jun 30, 1986 | |
|---|-------|---|---|--|-----------------------------|
| 1a. REPORT SECURITY CLASSIFICATION Unclassified | | | 1b. RESTRICTIVE MARKINGS | | |
| 2a. SECURITY CLASSIFICATION AUTHORITY | | | 3. DISTRIBUTION/AVAILABILITY OF REPORT Approved for public release; distribution unlimited. | | |
| 2b. DECLASSIFICATION/DOWNGRADING SCHEDULE | | | 5. MONITORING ORGANIZATION REPORT NUMBER(S) Technical Report REMR-HY-2 | | |
| 4. PERFORMING ORGANIZATION REPORT NUMBER(S) | | | 7a. NAME OF MONITORING ORGANIZATION USAEWES Structures Laboratory | | |
| 6a. NAME OF PERFORMING ORGANIZATION US Army Cold Regions Research and Engineering Laboratory | | 6b. OFFICE SYMBOL (If applicable) CRREL-EI | 7b. ADDRESS (City, State, and ZIP Code) PO Box 631 Vicksburg, MS 39180-0631 | | |
| 6c. ADDRESS (City, State, and ZIP Code) 72 Lyme Road Hanover, NH 03755-1290 | | | 9. PROCUREMENT INSTRUMENT IDENTIFICATION NUMBER | | |
| 8a. NAME OF FUNDING/SPONSORING ORGANIZATION US Army Corps of Engineers | | 8b. OFFICE SYMBOL (If applicable) | 10. SOURCE OF FUNDING NUMBERS | | |
| 8c. ADDRESS (City, State, and ZIP Code) Washington, DC 20314-1000 | | | PROGRAM ELEMENT NO. | PROJECT NO. | TASK NO. |
| 11. TITLE (Include Security Classification) Floating Debris Control; A Literature Review | | | WORK UNIT ACCESSION NO. | | |
| 12. PERSONAL AUTHOR(S) Perham, Roscoe E. | | | | | |
| 13a. TYPE OF REPORT Final report | | 13b. TIME COVERED FROM _____ TO _____ | | 14. DATE OF REPORT (Year, Month, Day) June 1987 | 15. PAGE COUNT 67 |
| 16. SUPPLEMENTARY NOTATION A report of the Hydraulics problem area of the Repair, Evaluation, Maintenance, and Rehabilitation (REMR) Research Program. Available from National Technical Information Service, 5285 Port Royal Road, Springfield, VA 22161. | | | | | |
| 17. COSATI CODES | | | 18. SUBJECT TERMS (Continue on reverse if necessary and identify by block number) | | |
| FIELD | GROUP | SUB-GROUP | Debris booms Trash struts | | |
| | | | Floating debris | | |
| | | | Trash racks | | |
| 19. ABSTRACT (Continue on reverse if necessary and identify by block number) <p>Floating debris can have an extremely harmful effect on certain hydraulic structures such as flood control works and navigation facilities and is consequently an important concern in maintenance and repair activities. This report assembles information found in published sources about equipment and methods used to control floating debris. Also included is an appendix on booms, their functions in the water transportation of pulpwood, and results of laboratory tests of various boom designs which was previously published by the Pulp and Paper Research Institute of Canada and which contains much useful information applicable to booms for control of floating debris.</p> | | | | | |
| 20. DISTRIBUTION/AVAILABILITY OF ABSTRACT <input checked="" type="checkbox"/> UNCLASSIFIED/UNLIMITED <input type="checkbox"/> SAME AS RPT <input type="checkbox"/> DTIC USERS | | | 21. ABSTRACT SECURITY CLASSIFICATION Unclassified | | |
| 22a. NAME OF RESPONSIBLE INDIVIDUAL Roscoe E. Perham | | | 22b. TELEPHONE (Include Area Code) 603-646-4309 | 22c. OFFICE SYMBOL CRREL-EI | |

SECURITY CLASSIFICATION OF THIS PAGE

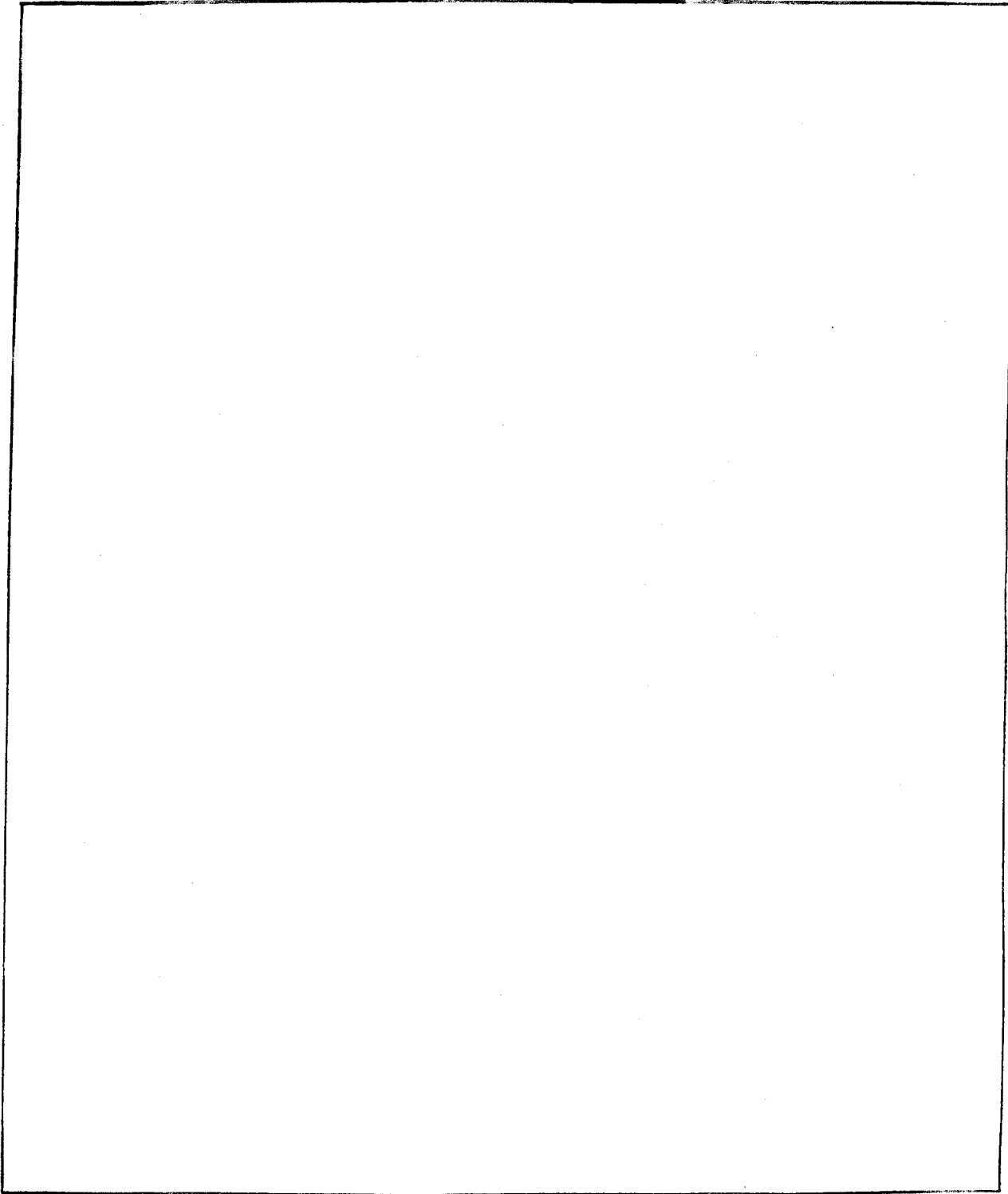

SECURITY CLASSIFICATION OF THIS PAGE

PREFACE

This investigation was performed by the U.S. Army Cold Regions Research and Engineering Laboratory (CRREL) for Headquarters, U.S. Army Corps of Engineers (HQUSACE). The investigation was conducted under the Hydraulics problem area of the Repair, Evaluation, Maintenance, and Rehabilitation (REMR) Research Program as part of Work Unit 32320, "Floating Debris Control Systems."

The REMR Overview Committee of HQUSACE, which approved this study, consists of Mr. James E. Crews, Mr. Bruce L. McCartney, and Dr. Tony C. Liu. REMR Coordinator for the Directorate of Research and Development, HQUSACE, is Mr. Jesse A. Pfeiffer, Jr., and the REMR Program Manager is Mr. William F. McCleese, Concrete Technology Division, Structures Laboratory, U.S. Army Engineer Waterways Experiment Station (WES). Mr. Glenn Pickering, Hydraulic Structures Division, Hydraulics Laboratory, WES, is Problem Area Leader for the Hydraulics problem area, and Mr. McCartney is the Technical Monitor.

This report was prepared by Mr. Roscoe E. Perham, under the supervision of Mr. Gunther Frankenstein, Chief, Ice Engineering Research Branch, CRREL.

Commander and Director of CRREL during publication of this report was COL Morton C. Roth, CE. Technical Director was Dr. Lewis E. Link, Jr.

COL Dwayne G. Lee, CE, is Commander and Director of WES. Technical Director of WES is Dr. Robert W. Whalin.

CONTENTS

| | <u>Page</u> |
|---|-------------|
| PREFACE | 1 |
| CONVERSION FACTORS, NON-FEDERAL TO SI (METRIC) UNITS OF MEASUREMENT | 3 |
| PART I: INTRODUCTION | 4 |
| Background | 4 |
| Objective | 4 |
| Scope | 5 |
| PART II: FLOATING DEBRIS PROBLEMS | 6 |
| PART III: CORPS OF ENGINEERS EXPERIENCE | 9 |
| Hydroelectric Dams and Reservoirs | 9 |
| Navigation Facilities | 14 |
| Levees and Debris Disposal | 15 |
| PART IV: BUREAU OF RECLAMATION GUIDANCE | 17 |
| PART V: NON-FEDERAL GUIDANCE | 18 |
| REFERENCES AND BIBLIOGRAPHY | 21 |
| GLOSSARY | 22 |
| APPENDIX A | A1 |

CONVERSION FACTORS, NON-SI TO SI (METRIC)
UNITS OF MEASUREMENT

Non-SI units of measurement used in this report can be converted to SI (metric) units as follows:

| <u>Multiply</u> | <u>By</u> | <u>To Obtain</u> |
|-----------------------|------------|-------------------------|
| cubic feet | 0.02831685 | cubic metres |
| cubic feet per second | 0.02831685 | cubic metres per second |
| feet | 0.3048 | metres |
| feet per second | 0.3048 | metres per second |
| inches | 25.4 | millimetres |

FLOATING DEBRIS CONTROL; A LITERATURE REVIEW

PART I: INTRODUCTION

Background

1. A study of floating debris control problems may seem unusual for research since floating debris has been with us in clearly identifiable form and in bountiful supply for a long time. Floating debris would also appear adaptable to being handled and disposed of by ordinary methods and equipment. However, the presence of this material in the wrong place at the wrong time can have an extremely harmful effect on certain structures such as flood control works and navigation facilities. It can also degrade the performance of water intakes for a variety of essential and valuable utilities such as hydroelectric plants, cooling systems for thermal electric plants and process industries, and municipal water supplies. Thus, the problem of floating debris, especially as it affects Corps of Engineers hydraulic structures, is an important concern in maintenance and repair activities and consequently is an appropriate subject for research under the Repair, Evaluation, Maintenance, and Rehabilitation (REMR) Research Program.

2. The term "debris" is often associated with rubble in the form of rock (Tatum 1963), hence the use here of the term "floating debris." The term "woody debris," which is used by the U.S. Forest Service, is also very descriptive. The floating debris found in most navigable waterways and in rivers passing through cities and towns contains considerable trash and garbage; however, most of the debris is woody. The debris of the Chena River in Alaska is over 99% wood (McFadden and Stallion 1976). As far as the technical accuracy of the term floating debris, it should be noted that floating indicates not only floating on the water's surface but also suspended at some depth beneath it.*

* A glossary of other unusual terms used herein is included at the end of this report.

Objective

3. The objective of the REMR floating debris control systems study is to provide more functional structures and arrangements for removing floating debris from rivers and streams. The work involved in meeting this objective will include literature searches, site visits to observe floating debris control systems in use by the private and the governmental sectors, field studies of control structures and floating debris, and a limited laboratory study.

Scope

4. This report assembles information found in published literature about equipment and methods used to control floating debris. The range and extent of floating debris problems and effects are touched upon, but a substantial amount of information on these aspects was not found in the literature. A good summary of the means and methods is found in the hydroelectric handbook by Creager and Justin (1950). Much information was also gleaned from various Corps of Engineers and Bureau of Reclamation technical publications and other literature related to the civil engineering hydrology field. One particularly informative source, a monograph on booms, their function in the water transportation of pulpwood, and results of some laboratory tests of various boom designs, is reproduced as Appendix A.

5. Another report will be forthcoming on other aspects of floating debris control systems such as natural effects and site preparations and the collection, holding, removal, and disposal of floating debris. Much of this information relates to the equipment and techniques described in this report, yet it will provide details on things found during field trips such as a new trash rake, a bulldozer blade for making high debris piles, and the technique of lowering water levels to make debris accessible.

PART II: FLOATING DEBRIS PROBLEMS

6. Floating debris problems arise in almost every type of water body, but the nature of these problems and their severity vary substantially. For instance, at the 1564-MW (220,000-cfs* flow) Beauharnois Powerhouse on the St. Lawrence River, west of Montreal, from 10 to 25 truckloads of debris, mostly wood, are removed each year.** Dealing with this debris is a very minor problem to the powerhouse staff. At times, however, similar quantities are removed each week from the 49-MW (31,200-cfs water flow) Racine Hydroelectric Plant on the Ohio River. Debris is a problem at Racine, and often its removal (lifting out, hauling away, dumping, etc.) involves the efforts of over half the work force.†

7. Occasionally a dam gate will become stuck partly open by debris intrusion (Figure 1), and rather severe downstream bed scour can occur before the debris can be removed and the gate closed (Munsey 1981). Similarly severe problems can occur on rivers where floating debris accumulates on bridge piers and causes deep scouring (Rowe 1974). These events occur during floods, and the situation is summarized by Klingeman (1973):

The rivers of the Pacific Northwest carry much debris during floods. The streamlined piers of bridges constructed in recent years tend to deflect most debris. But branches and tree trunks can become enmeshed against even the most streamlined piers. For older bridges, the problem of debris jams is worse due to less streamlined piers and to the character of the undersides of superstructures (which often snag debris more readily than for new bridge superstructures). Debris caught against piers increases their effective size, concentrates the local flow, causes deeper scour, and can place loads on the structure for which it was not designed. Debris caught on the superstructure, abutments, and approach spans blocks part of the waterway and concentrates the streamflow in the remainder of the bridge opening - increasing velocities, water depths, and

* A table of factors for converting non-SI units of measurement to SI (metric) units is presented on page 3.

** J. G. Fournier, Beauharnois Powerhouse, personal communication, 1985.

† H. Huck, Racine Hydroelectric Plant, personal communication, 1985.

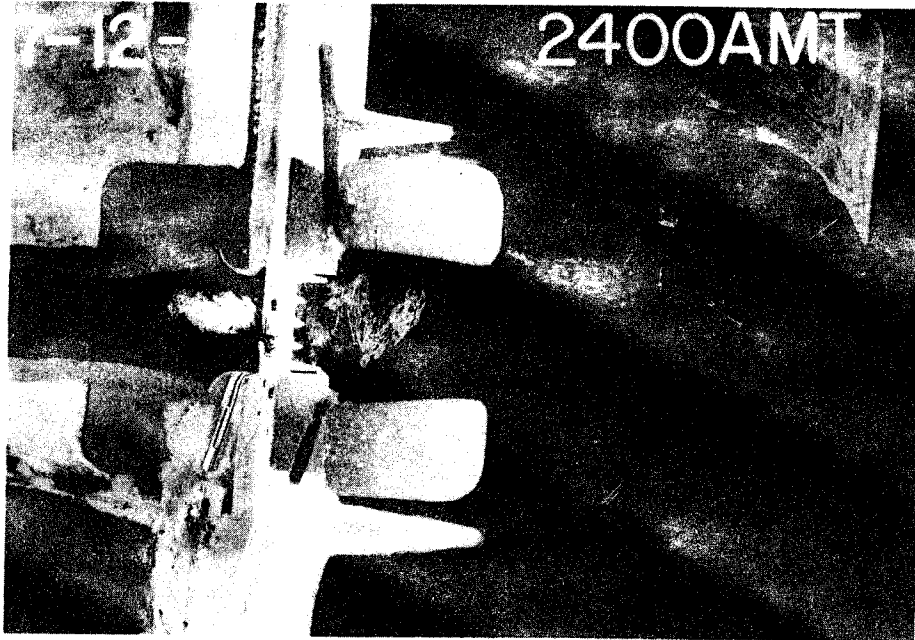

Figure 1. Aerial view of floating debris, mostly whole trees, at an Alaskan flood control dam. Central gate is blocked partly open causing some downstream scour. Water flows right to left.

scour. In some pier designs, because of economy, footings may be placed on piles above the level of maximum scour. Such footings are generally riprapped. However, in the event of riprap scour, it can happen that debris may lodge in the piling, tending to increase scour even more.

8. Floating debris that collects at hydropower plants, municipal and industrial water intakes, and in flood control reservoirs poses generally less severe problems. Some cooling water intakes, though, are of critical importance, and their blockage may dictate that emergency procedures be used to avoid damage. Figure 2 shows floating debris being held back from an outlet structure at a flood control dam by a log boom. The reservoir is for the temporary storage of flood waters on a small river, and the debris causes no problems whatsoever. However, should the reservoir be used to store more water and to accommodate recreation, then the debris might become a hazard, especially to boats, and need to be removed more frequently.

9. At some dams, floating debris collects upstream and downstream of the structure, in a circulating flow, yet the dams are not equipped to remove it. The debris can bump and scrape against the gates degrading their

appearance and possibly reducing their service life. Furthermore, as wood remains in the water much of it becomes waterlogged and submerged and tends to get under gates. Eventually, most of this material is passed downstream.

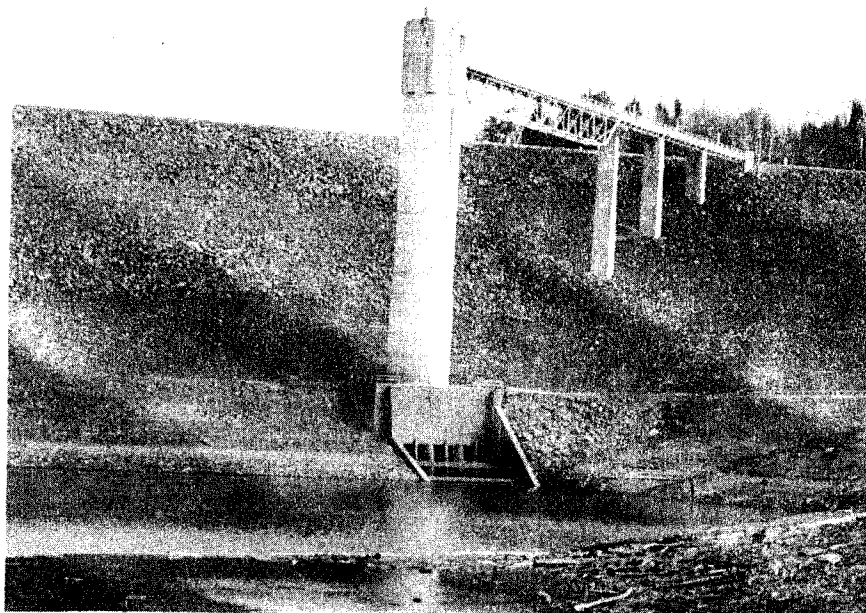

Figure 2. Debris boom and debris at a Corps of Engineers flood control reservoir near North Hartland, Vermont.

10. Floating logs and trees can also damage the upstream slopes of dams. They can be carried by waves and hammered like battering rams against a dam (Blake 1975). In the process, hand-placed riprap can be torn out and subsequent wave action can lead to rapid degradation of slopes.

PART III: CORPS OF ENGINEERS EXPERIENCE

11. There are several Corps of Engineers publications that mention floating debris control factors and floating debris effects. (There is probably sufficient information in the Corps literature to cover the design of trash racks, trash struts, trash beams, and trash fenders.) Floating debris is an important factor to consider in the design of outlet works for dams and reservoirs and in the design of navigation locks; it can also cause problems at levees. The primary need for control is to prevent debris from obstructing water passage or damaging equipment such as turbines. In addition, the need depends on several factors such as the location of the dam relative to reservoir areas producing floating debris and the size and location of sluices within a dam. (As a reference, sluices are outlet works through gravity dams, and conduits or tunnels are outlet works through embankment dams.)

Hydroelectric Dams and Reservoirs

12. The sluice intakes of reservoir outlet works are protected from debris by trash struts or trash racks depending upon the need for protection against clogging and debris damage to gates and turbines. Engineer Manual (EM) 1110-2-1602 (Office, Chief of Engineers (OCE) 1980a) provides the descriptions that follow.

Trash struts

13. A simple trash strut, beam, or fender usually of reinforced concrete with clear horizontal and vertical openings not more than two-thirds the gate or other constricted section width and height, respectively, should be adequate for highly submerged, flood control reservoir outlet conduits. The purpose of such struts (Figure 3) is to catch trees and other large debris which may reach the entrance but would not pass through the gate passage, thereby possibly preventing closure of the gates. Trash struts should be located to effect local net area velocities not greater than 15 fps. A flow net or model test should be used to determine local velocities through this area. The struts should be circular cylinders or have rounded noses and square tails, depending upon the structural design requirements and economy. Teardrop designs are not required if the local velocity guidance is maintained. Trash strut head losses are usually included in the overall intake

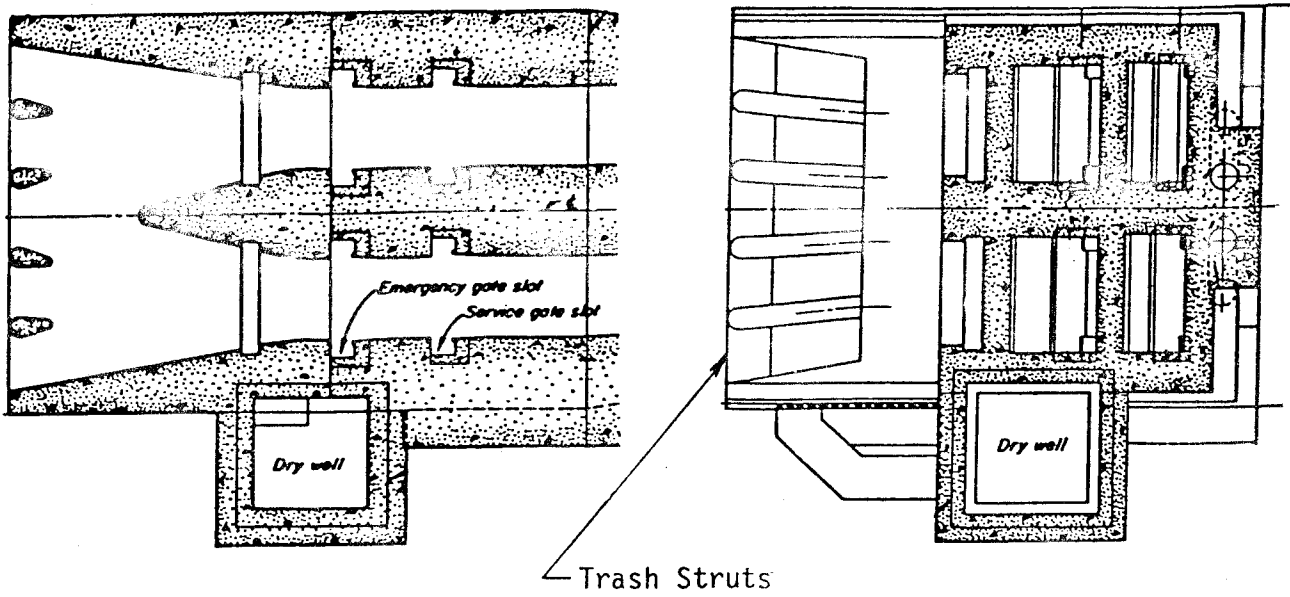

SECTIONAL PLAN AT ELEVATION 1223.00

SECTIONAL PLAN AT ELEVATION 1262.00

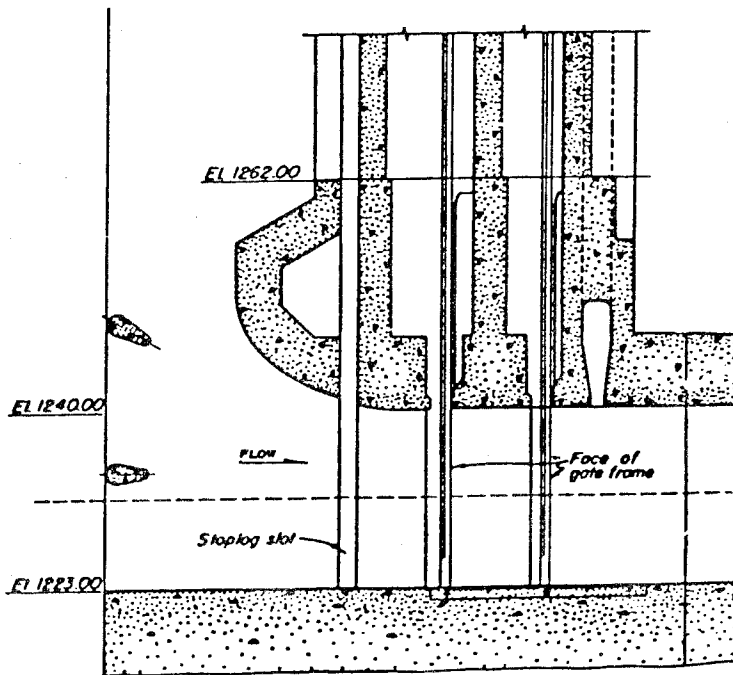

ELEVATION SECTION THROUGH GATES

Figure 3. Sectional views of trash struts at an intake to a reservoir outlet.

loss (Figure 4). If necessary to consider separately, it is recommended that the following equation be used with a loss coefficient K value of 0.02:

$$H_1 = K \frac{V^2}{2g} \quad (1)$$

where

H_1 = head loss, ft

K = dimensionless coefficient usually determined experimentally

V = reference velocity, ft/sec

g = acceleration due to gravity, ft/sec²

V in this equation is the flow velocity in the uniform conduit section just inside the intake. Trash struts should be provided with a working platform located above conservation pool elevation to facilitate removal of debris. Additional information on the design of trash struts is given in EM 1110-2-2400 (OCE 1964).

14. The above-mentioned debris preventing closure of a gate is a very serious problem which can lead to scour downstream of some dams. EM 1110-2-2400 states in a later section that "Degradation, or lowering of the river bed, immediately downstream of a dam may threaten the integrity of the structure."

Trash racks

15. Trash racks are provided where debris protection for downstream devices such as valves or turbines is required (Figure 5). These racks are designed to retain debris of a size and type of material that could result in damage to these devices. Because of danger of overstressing from clogging, trash racks should be located in lower velocity areas than trash struts, and must be provided with raking or cleaning facilities. They should be designed for safe operation with 50 percent clogging. Such devices can be fabricated from circular bars and pipe. Trash racks should not be located in velocities exceeding 3 to 4 fps. Where additional strength is required, elongated sections with rounded noses and tails can be used. Trash rack head losses depend on the flow velocity and area constriction. The design of vibration-free trash racks is necessary to prevent failure from material fatigue, a consideration that is especially important where reverse flow can occur.

16. As described further in EM 1110-2-3001 (OCE 1960), trash racks at hydroelectric power plants are usually vertical in order to economize on

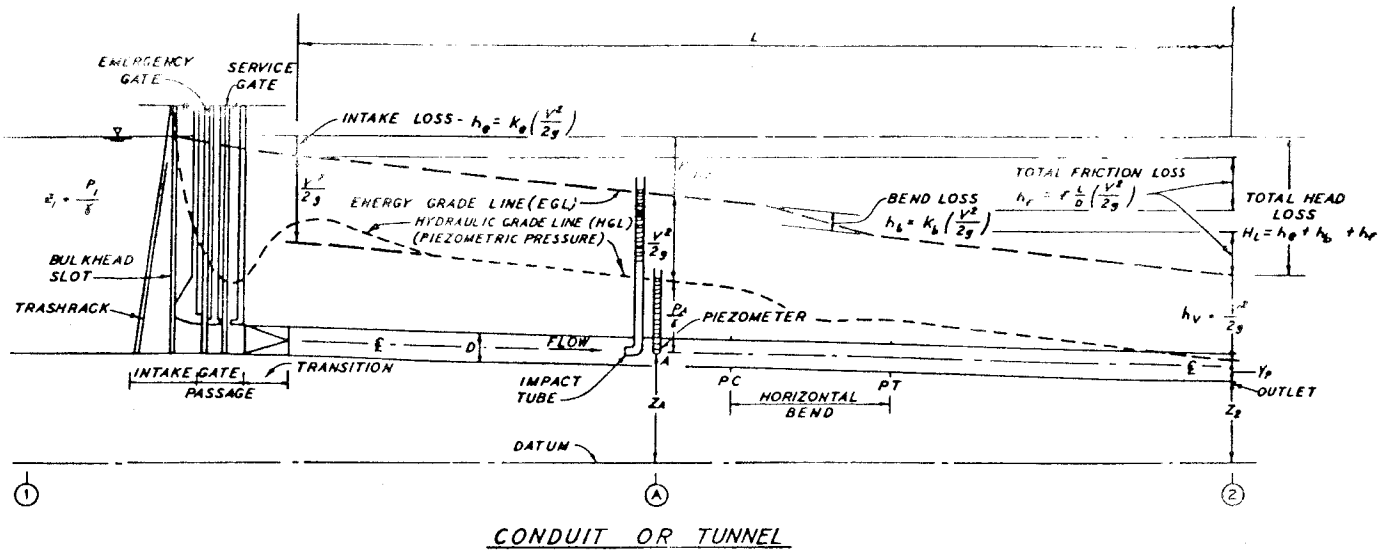

Figure 4. Pressure flow definition sketch.

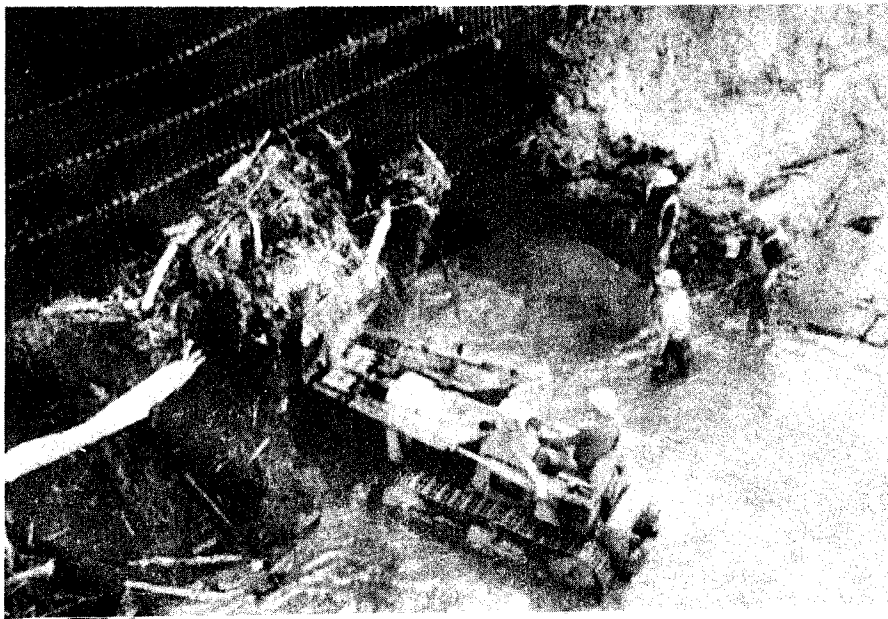

Figure 5. Removing debris and silt from the upstream side of the trash racks (dewatered) of the Black Eagle hydroelectric plant intake on the Missouri River at Great Falls, Montana.

length of intake structure. For very low-head intakes, however, where the increase in length of structure would be small and where considerable trash

accumulation may be expected, they are often sloped to facilitate raking. Water velocities at the racks should be kept as low as economically practicable with a maximum, for low-pressure intakes, of about 4 fps. For high-pressure intakes, greater velocities are permissible but should not exceed about 10 fps.

17. The racks are usually designed for an unbalanced head of 10 to 20 ft of water and are fabricated by welding together a number of sections of a size convenient for handling. For low-head intakes, stresses due to complete stoppage and full head should be investigated and should not exceed 150% of normal stresses. If the racks are to be sheathed for the purpose of dewatering the intake, case II working stresses should not be exceeded for that loading condition. The clear distance between rack bars varies from 2 to 6 in. or more, depending on the size and type of turbine and the minimum operating clearances. Bar thickness should be consistent with structural design requirements, with the vibrational effects resulting from flowing water being considered. A thick bar should be used with the depth of the bar controlled by the allowable working stress.

18. The design of the guides and centering devices for the rack sections should receive careful attention. Clearances should be small enough to prevent offsets from interfering with removal of the racks or with operation of a rake if one is provided. Corrosion-resisting clad steel is satisfactory for the purpose.

19. For high-pressure intakes in concrete dams, the trash rack supporting structure is sometimes built out from the face of the dam in the form of a semicircle in order to gain rack area to maintain low velocities.

20. Other factors to consider are that the design should prevent undesirable vortices; i.e., vortices of such intensity that they draw air and surface debris into the structure. It is usually advantageous to have gates and trash structures at the upstream end of outlet works. Also, upstream bulkhead slots or other provisions for maintenance and repairs are required; these slots may also be used for trash racks. Finally, in the design of spillway tainter gates, the trunion should be located above the maximum flood nappe to avoid contact with floating ice and debris.

Navigation Facilities

21. Floating debris and fragmented ice are often lumped together in descriptions in spite of their important differences such as density, melting points, and freeze bonding. In this section, the latter (ice) will not be considered. EM 1110-2-1611 (OCE 1980b) states that ports in the upper guard wall should increase the tendency for floating debris to be trapped in the lock approach. A long guide wall and short guard wall will reduce the amount of debris trapped in the lock approach but, at the same time, will generally preclude the use of an adequate number of ports to eliminate or substantially reduce cross currents near the end wall. EM 1110-2-1611 further states that the probability of the accumulation and movement of floating debris should be considered in the design of spillways, locks and dams, channel alignment and dimensions, and necessary training and stabilization structures. Some provisions that might be considered are:

- a. Air bubbler screen or boom designed to divert debris away from the lock approach.
- b. High-flow air screens in gate recesses.
- c. Lock emergency gates designed and maintained for passing debris.

22. Lock emergency gates are considered further in EM 1110-2-1604 (OCE 1956) which states that submergible vertical lift gates provided with overflow crests are used for passing debris (Figure 6). The submergible gates are practical, however, only where the sill is sufficiently high to permit the gate to be dropped completely below its top surface. Submergence into a floor recess is not considered advisable because of the possibility that silt and debris lodged in the recess would interfere with its operation. Under some circumstances, drift (floating debris) conditions may be too severe to permit flow through sector gate recesses. The flow through the sector gate leaves may have to be combined with a loop culvert filling system. In the design of end filling or emptying systems, submersible lock gates should be designed with a view towards obtaining the best operation for passing debris and flood discharge.

23. Relative to the sidewall culvert filling and emptying systems at locks, the use of several small intake openings is better structurally when the openings are located in a lock wall. Trash racks can also be kept to a

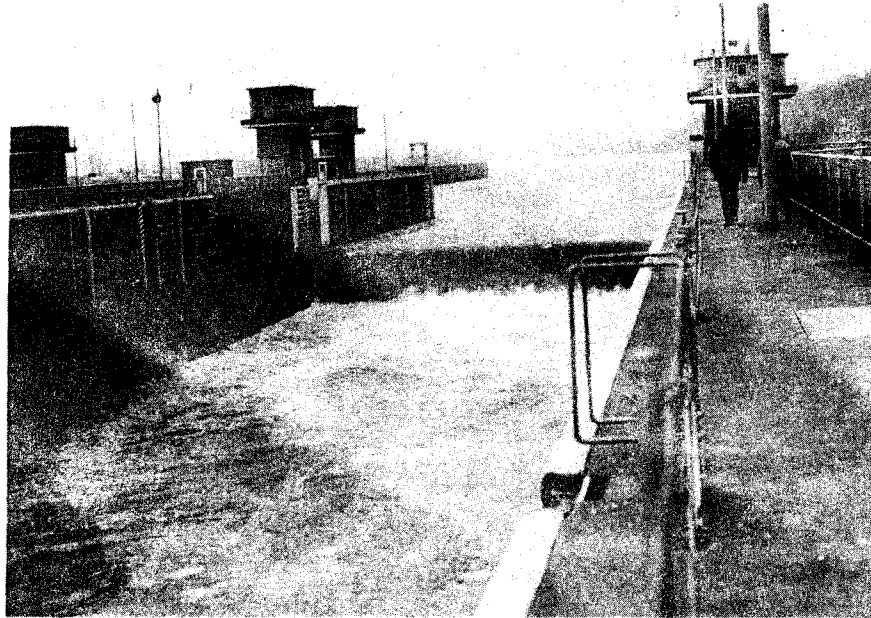

Figure 6. Emergency gates used as a spillway at Racine Lock and Dam, Ohio River.

reasonable size by the use of several small openings. When the intakes are located near to the upper pool level where floating ice and debris can easily reach them, the gross intake velocity is usually limited to 8 to 10 fps to avoid damage to the racks by impact.

Levees and Debris Disposal

24. Two more areas of guidance come from EM 1110-2-1913 (OCE 1978). The first is a precaution about pipelines crossing levees: "all pipes on the water side of the levee should have a minimum of 1 ft of soil cover for protection from debris during high water"; i.e., debris carried by fast-moving currents. The second area is the disposal of debris. Debris from clearing, grubbing, and stripping operations can be disposed of by burning in areas where this is permitted. When burning is prohibited by local regulations, disposal is usually accomplished by burial in suitable locations near the project such as old sloughs, ditches, and depressions outside the limits of

the embankment foundation but within project rights-of-way. Debris may also be stockpiled for later burial in excavated borrow areas. Debris should never be placed in areas where it may be carried away by streamflow or where it blocks drainage of an area. After disposal, the debris should be covered with at least 3 ft of earth and a vegetative cover established.

PART IV: BUREAU OF RECLAMATION GUIDANCE

25. In its publication Design of Small Dams, the Bureau of Reclamation (1977) provides guidance for the design of inlet structures and trash racks. Flow equations and coefficients are included. Some guidance not covered sufficiently by the Corps literature is excerpted and given here:

The required area of the trash rack is fixed by a limiting velocity through the rack, which in turn depends on the nature of the trash which must be excluded. Where the trash racks are inaccessible for cleaning, the velocity through the racks should not exceed 2 feet per second. A velocity of up to approximately 5 feet per second may be tolerated for racks which are accessible for cleaning.

Also,

Screens are required in some localities to prevent fish from entering the irrigation canal. [This applies also some to other waterways]. Their use will depend on the species of fish and their importance from the standpoints of recreation, industry, and conservation, and also on the legislation or ordinances governing fish control. Fish screens may be classified in three groups as stationary, mechanical, or electrical, and may involve the use of either bars or screens. Migratory fish require a fish ladder or other means for allowing them to pass the dam.

26. This Bureau publication further includes sample provisions or specifications for clearing a reservoir area below some particular elevation of all floatable and combustible materials (i.e., standing and down timber, brush, etc.) and for disposal of these materials. Methods of disposal discussed are burying, burning, chipping, and trimming and cutting to length. It is generally assumed that the materials from clearing operations become the property of the contractor.

27. Provisions for cleaning trash racks and screens are touched upon. Because small openings must be used to exclude fish, the screens can easily become clogged with debris. Provisions must therefore be made for periodically removing the screens and cleaning them by brooming or water jetting.

28. The trash rack of the 575-ft-long All-American Canal headworks is cleaned with a mechanical rake which consists of a motor-driven traveling gantry equipped with a motor-operated hoist and a rake unit. The trash is dumped into trash cars which travel along the top of the trash rack structure.

PART V: NON-FEDERAL GUIDANCE

29. Comprehensive discussions of a wide variety of factors related to hydroelectric dams and power generation are found in the hydroelectric handbook by Creager and Justin (1950). Included are several items related to floating debris control. Examples of trash racks, mechanical rakes, and debris booms with some details are provided. Hand raking of trash racks at low-head dams is mentioned; the use of compressed air bubbler systems to greatly minimize the cleaning of trash racks is also mentioned.

30. The handbook says that it is usually necessary to provide a deflecting device in the dam forebay, an enlarged body of water just upstream of the intakes. This often consists of a boom, preferably at an angle of 30 to 45 degrees to the direction of flow, to divert ice and trash from the intake to the spillway or to a sluiceway at one end of the intake. A typical system is shown in Figures 7 and 8, which are photographs of the Appalachian Power Company facility at the Winfield Lock and Dam on the Kanawha River. The cross section of the boom is shown in Figure 9. The use of cables for structures, intermediate anchors lines, and anchor connections that are free to rise and fall with fluctuations in the water surface is discussed.

31. Also provided is a method for calculating the load in a boom structure. The tension in the boom depends on the distance the boom projects below water surface, the velocity of the water, and the sag in the boom. For practical purposes, the tension in a boom can be obtained by assuming the boom to be an arc of a circle and the pressures radial. Let

R = radius of curvature of the boom, ft

α = angle of the chord of the arc to the direction of flow

d = depth of the boom below water surface, ft

v = velocity of water, fps

g = acceleration of gravity = 32.2

w = weight of 1 cu ft of water, lb = 62.5

T = total tension in the boom, lb



Figure 7. Debris diversion boom and debris, Appalachian Power Company Station at Winfield Lock and Dam, Kanawha River, West Virginia.

Then,

$$T = \frac{wRdv^2}{g} (\sin \alpha) = 1.94 Rdv^2 (\sin \alpha) \quad (2)$$

Ample allowances should be made for the indeterminate effect of wind and the friction of flowing water on an accumulation of ice and debris against the boom, and also for the impact of this accumulation.

32. Thorn (1966) describes the use of a mechanical weed screen to remove debris at the intake to a land drainage pumping station in England. The system is automatic, and high-pressure water jets flush the debris into a trough leading to a collection tank. A conventional screen (trash rack) is provided in case the automatic screen malfunctions.

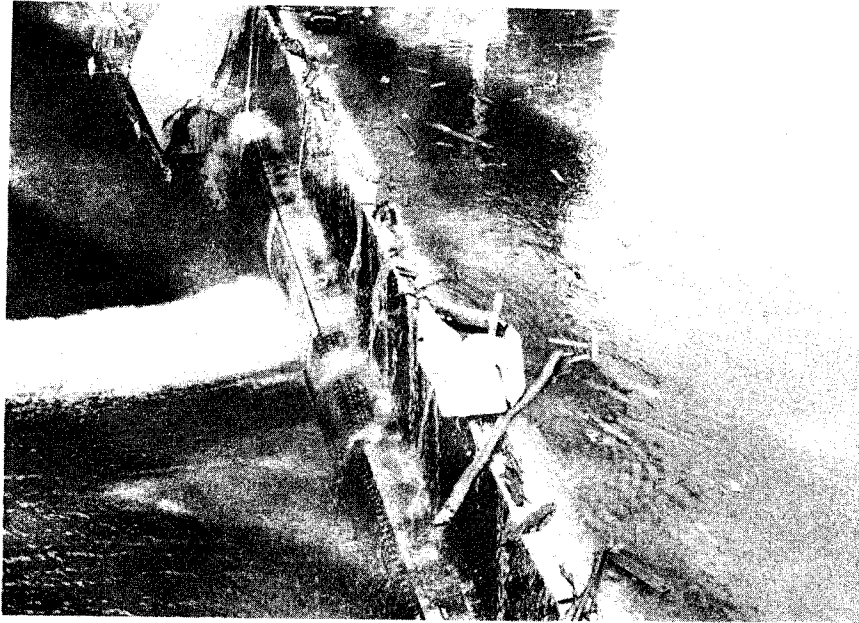

Figure 8. Debris sluice flap on roller drum gate at Winfield Lock and Dam. Large object is a refrigerator.

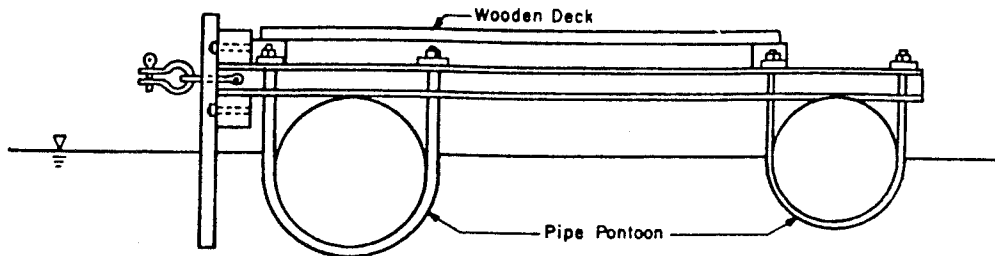

Figure 9. Cross section of the boom shown in Figure 7.

REFERENCES AND BIBLIOGRAPHY

- Creager, W. P. and Justin, J. D. 1950. Hydroelectric Power, John Wiley and Sons, New York, pp 533-535.
- Klingeman, P. C. 1973. "Hydrologic Evaluations in Bridge Pier Scour Design," Journal of the Hydraulics Division, Proceedings of the American Society of Civil Engineers, Vol 99, No. HY12, pp 2175-2184.
- McFadden, T. and Stallion, M. 1976. "Debris of the Chena River," U.S. Army Cold Regions Research and Engineering Laboratory, Hanover, N.H.
- Munsey, T. 1981. "Trip Report to Alaska District on Problems Associated with the Fairbanks Flood Control Project, 21-25 September 1981," U.S. Army Cold Regions Research and Engineering Laboratory, Hanover, N.H.
- Office, Chief of Engineers, Department of the Army. 1956. "Hydraulic Design of Navigation Locks," Engineer Manual 1110-2-1604, Washington, D.C.
- _____. 1958. "Gravity Dam Design," Engineer Manual 1110-2-2200, Washington, D.C.
- _____. 1960. "Planning and Design of Hydroelectric Power Plant Structures," Engineer Manual 1110-2-3001, Washington, D.C.
- _____. 1964. "Structural Design of Spillways and Outlet Works," Engineer Manual 1110-2-2400, Washington, D.C.
- _____. 1966. "Design of Spillway Tainter Gates," Engineer Manual 1110-2-2702, Washington, D.C.
- _____. 1978. "Design and Construction of Levees," Engineer Manual 1110-2-1913, Washington, D.C.
- _____. 1980a. "Hydraulic Design of Reservoir Outlet Works," Engineer Manual 1110-2-1602, Washington, D.C.
- _____. 1980b. "Layout and Design of Shallow Draft Waterways," Engineer Manual 1110-2-1611, Washington, D.C.
- Rowe, R. R. 1974. "Discussion of P. C. Klingeman: 'Hydrologic Evaluations in Bridge Pier Scour Design,'" Journal of the Hydraulics Division, Proceedings of the American Society of Civil Engineers, Vol 100, No. HY8, pp 1190-1192.
- Sherard, J. L., Woodward, R. J., Gizienski, S. F., and Clevenger, W. A. Earth and Earth Rock Dams; Engineering Problems of Design and Construction, John Wiley and Sons, New York.
- Tatum, F. E. 1963. "A New Method of Estimating Debris Storage Requirements for Debris Basins," Proceedings of the Federal Inter-Agency Sedimentation Conference, U.S. Department of Agriculture, Miscellaneous Publication No. 970, Washington, D.C.
- Thorn, R. B. 1966. River Engineering and Water Conservation Works, Butterworth and Co., Ltd., London.
- U.S. Bureau of Reclamation. 1954. Dams and Control Works, U.S. Department of the Interior, Washington, D.C.
- _____. 1977. Design of Small Dams, U.S. Department of the Interior, Washington, D.C.

GLOSSARY

| | |
|--------------|--|
| Boom | A chain of logs, drums, or pontoons secured end-to-end and floating on the surface of a reservoir so as to divert floating debris, trash, and logs (also called a log boom). |
| Conduit | Outlet works through an embankment dam (also called a tunnel). |
| Intake | Any structure in a reservoir or dam or river through which water can be drawn into an aqueduct. |
| Log way | A chute or channel down which logs can be passed from the reservoir to the river downstream (also called a log chute). |
| Sluice | Outlet works through a gravity dam. |
| Trash fender | A device attached or set up in front of a sluice intake to prevent debris damage to gates and turbines. |
| Trash rack | A screen comprised of metal or reinforced concrete bars located in the waterway at an intake so as to prevent the ingress of floating or submerged debris. The term "screen" is used in the U.K. Hence the expressions: "fine screen" and "fish screen." |
| Trash struts | A streamlined bar or beam designed to resist pressure in the direction of its length and used as a debris control device. |

APPENDIX A

("Booms," in The Water Transportation of Pulpwood; III. Structures, by R. J. Kennedy and S. S. Lazier, 1965, reproduced with the permission of the publisher, Pulp and Paper Research Institute of Canada, Montreal.)

THE WATER TRANSPORTATION OF PULPWOOD III. Structures

by

R. J. Kennedy and S. S. Lazier

Chapter II. BOOMS

In the water transportation of pulpwood several different types of boom are used to perform three distinct functions. These functions and the types of boom used to fulfill them are described together with the results of laboratory tests of the various designs.

(a) Functions

(i) Holding booms.

Holding booms are employed to stop the floating logs at or near the mill and to hold the mass of logs against the forces exerted by water and wind. A holding boom must have good stopping characteristics to prevent the escape of the first logs and be sufficiently strong to withstand the thrust of the maximum accumulation of wood under the most adverse circumstances of flood and wind.

(ii) Towing booms.

Towing booms are used to surround and control quantities of loose logs which are being towed over areas of slack water. They must be able to retain logs against wave action and have sufficient strength to withstand the forces involved.

(iii) Glance booms.

Glance or guide booms in a river are used to guide floating logs away from eddies, back channels and obstructions toward the cleared channel. They must be capable of changing the direction of motion of the floating logs without stopping them or allowing any to escape. Glance booms do not ordinarily have to withstand the thrust of a large mass of pulpwood nor the forces of wind or waves to which holding booms may be subjected.

The types of boom used to perform these three functions are described below. The numerous designs now giving satisfactory service have been arbitrarily divided into representative types or classes. These types are described and discussed, then the results of laboratory tests are reported.

Most wooden booms absorb water and lose buoyancy with continued service. At least part of this loss may be recovered after a drying period, but the resistance of a boom stick to absorption is one of its important characteristics.

(b) Types of Holding Boom

(i) Round boom

Native soft wood logs 10 inches and up in diameter, fastened together with chain, are used for light holding jobs throughout eastern Canada. A typical application for such a boom would be the holding of pulpwood dumped into a small bay until it could be towed away.

Fig. 6 shows pulpwood pushed under a round boom which was in temporary use as a holding boom on a small river.

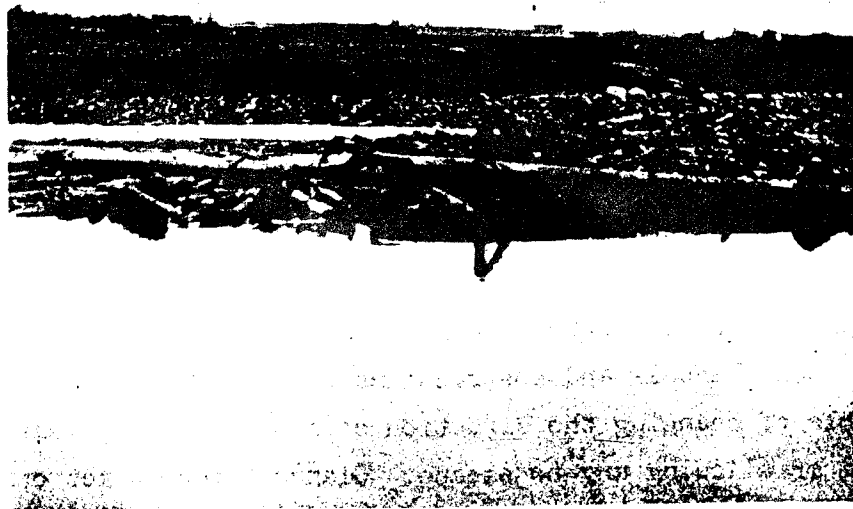

Fig. 6. Round Boom of Spruce Logs

On rivers flowing into Georgian Bay and elsewhere, particularly in the west, larger round sticks of 24 to 40 inches in diameter Sitka spruce are used. These have unusually good buoyancy characteristics, partly because of their greater diameter, but also because of the properties of the wood. Of course the larger sticks are suitable for much heavier service than are the small sticks. Two strings of Sitka spruce round boom sticks are reasonably effective against waves and are sometimes used for heavy towing or holding as shown in Fig. 7.



Fig. 7. Holding Boom Composed of Two Strings of Sitka Spruce

Large boom sticks which have a long service life are subject to much wear by the chain fastenings. Various kinds of wearing blocks, of which the hardwood type shown in Fig. 8 is most common, are used to protect the end of the stick.

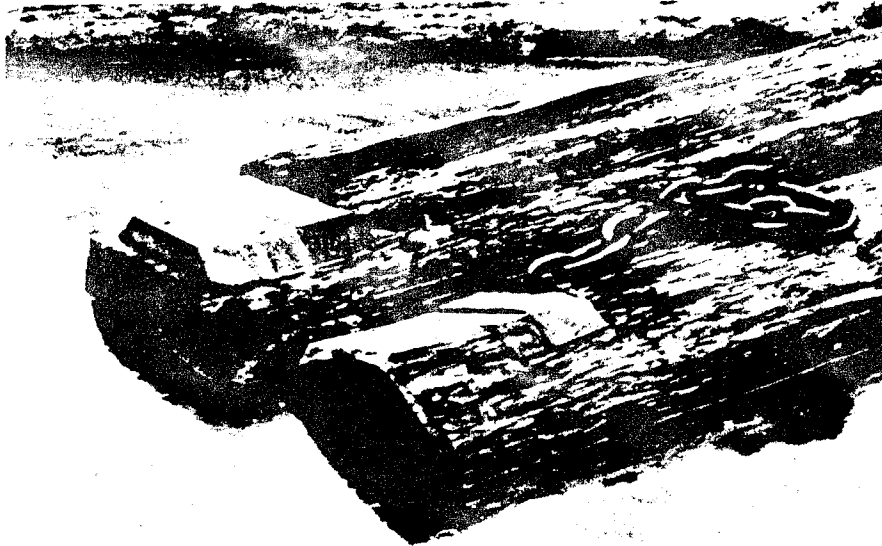

Fig. 8. Hardwood Wearing Blocks on Sitka Boom Sticks

(ii) Flat or walking boom.

In a holding ground where the boom is the most convenient working platform and means of access, flat booms of the type shown in Figs. 9 and 10 are often employed.

These booms usually consist of two to five square timbers bolted together and fastened at the ends with chain as seen in the figures. The timbers are usually 12 or 14 inches square Douglas Fir. Many companies make a practice of treating the square timbers with creosote before assembly. Although this increases the weight of the timber initially, it decreases the absorption rate and apparently prolongs the working life of the stick.

Flat booms are not particularly good for stopping wood and have a tendency to lift or to roll on edge if subjected to a heavy thrust by the pulpwood. Outriggers are sometimes used to keep these booms flat under load.

Fig. 10 shows pulpwood which has been pushed under a flat boom by a heavy thrust.

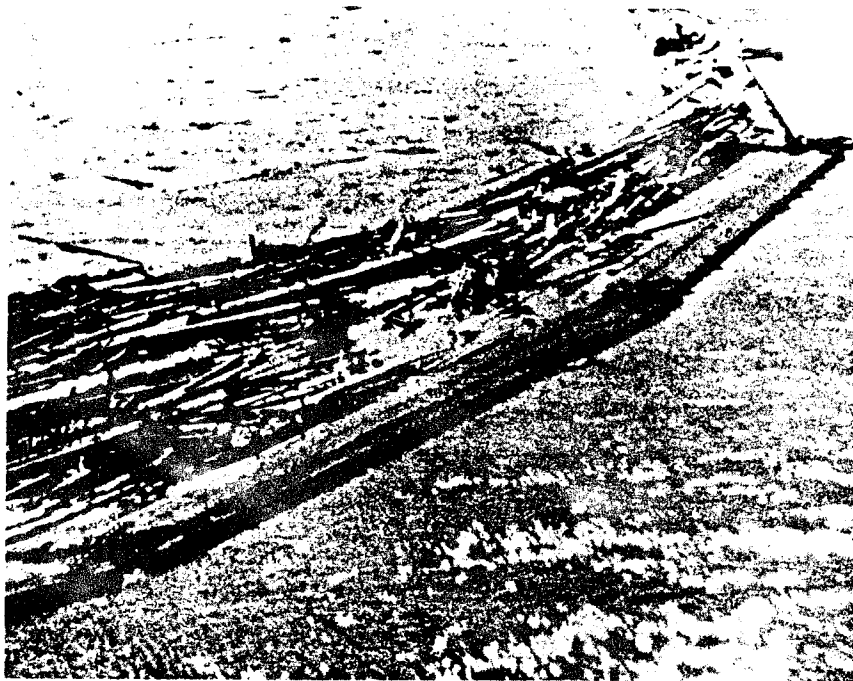

Fig. 9. Flat Boom Holding Debris, Logs and Ice



Fig. 10. Pulpwood Pushed Under a Flat Boom

(iii) Deep booms.

These are built to stop wood in faster water or to withstand very heavy loads. The core boom or Bathurst boom shown in Fig. 11 is reasonably effective in stopping logs in fast water or waves and can be made moderately strong.

Fig. 12 shows an extremely strong and heavy deep timber boom. Provision is made for the insertion of fence posts along the upstream face, if these should be needed to stop the wood.

A number of heavy duty connectors to join deep boom sticks have been developed. Fig. 13 shows three examples and several others are in use. None seem to have gained popularity outside the area for which it was developed.

(iv) Fence booms.

Fence booms are flat booms or deep booms which have been provided with an underwater fence to help stop the wood as it arrives. Where wave action may occur, the fence is occasionally extended above the top surface of the stick to prevent logs being forced over the top.

An example of a wooden fence boom is shown in Fig. 12 and of a steel pontoon fence boom in Fig. 14. Because of the leverage which can be exerted by the pulpwood against the fence, the boom sticks are often equipped with outriggers to prevent rolling.

(v) Net or cable booms.

These have been used in Russia for years but have been slow to gain adoption in North America. They combine excellent wood stopping ability with positive strength characteristics and commendable economy. The chief difficulty seems to be the lack of experience in the design and use of such booms. Two, which have been installed at the suggestion of the writers, and designed by the Oxford Paper Co. and Mr. J. Zorzi, P.E.Q. respectively, are shown in Figs. 15 and 16. The lighter boom was installed particularly because of its stopping ability; the heavier boom because both stopping ability and great strength were required.

The writers believe that heavy cable booms can be used to reduce the number of piers required or even to eliminate the piers entirely. This is especially important in deep water, where piers are costly. If a three cable net boom is regarded as a suspension bridge on its side there seems to be no reason why it can not be designed to resist substantial thrust loads even on a span of

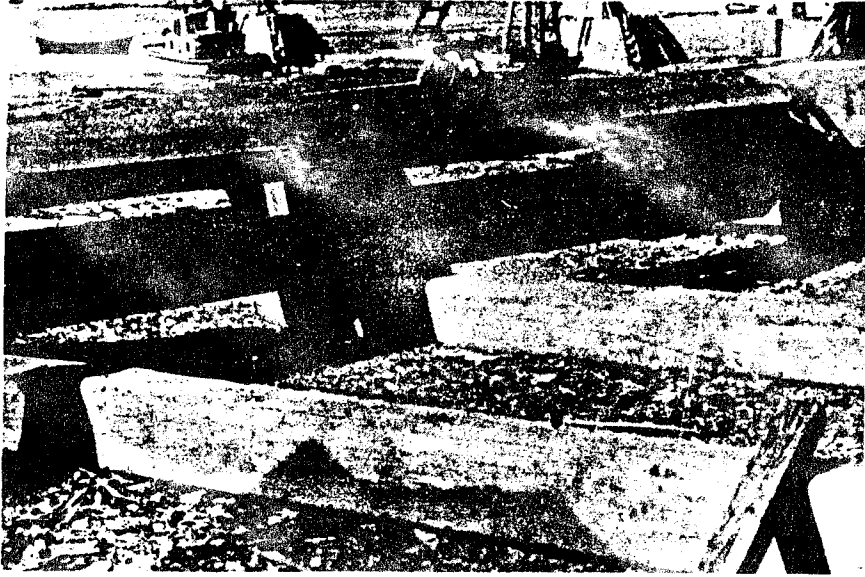

Fig. 11. Core or Bathurst Boom Under Construction



Fig. 12. Very Strong Deep Boom
(Note the retainers for fence posts along the face.)



(a)

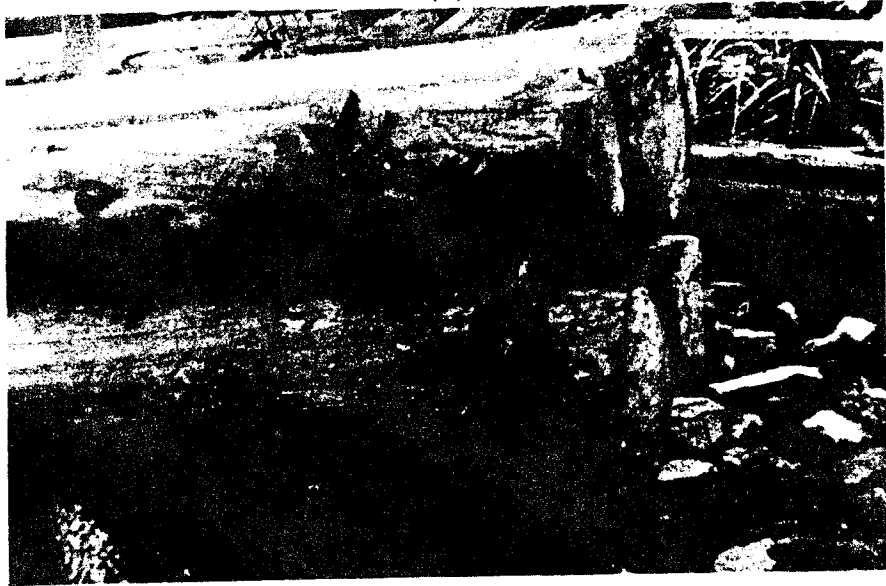

(b)



(c)

Fig. 13. Connectors
for Deep Booms



Fig. 14. Steel Pontoon Fence Boom in Winter Ice
(Posts are lowered before wood arrives.)

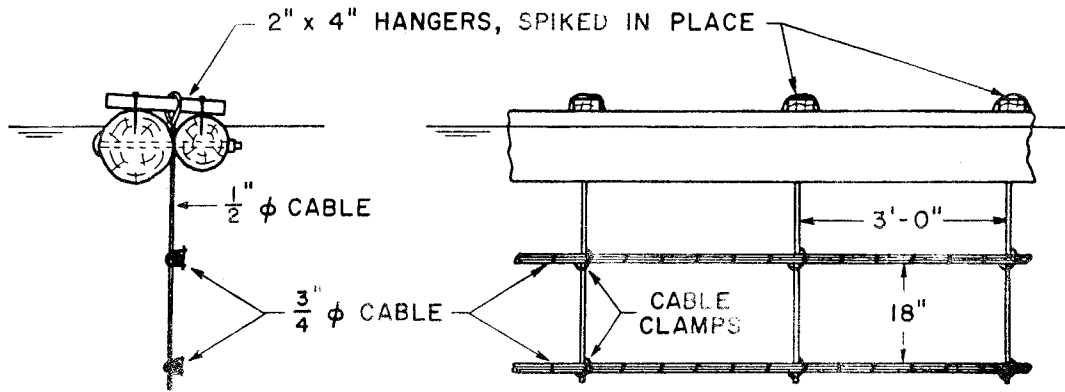
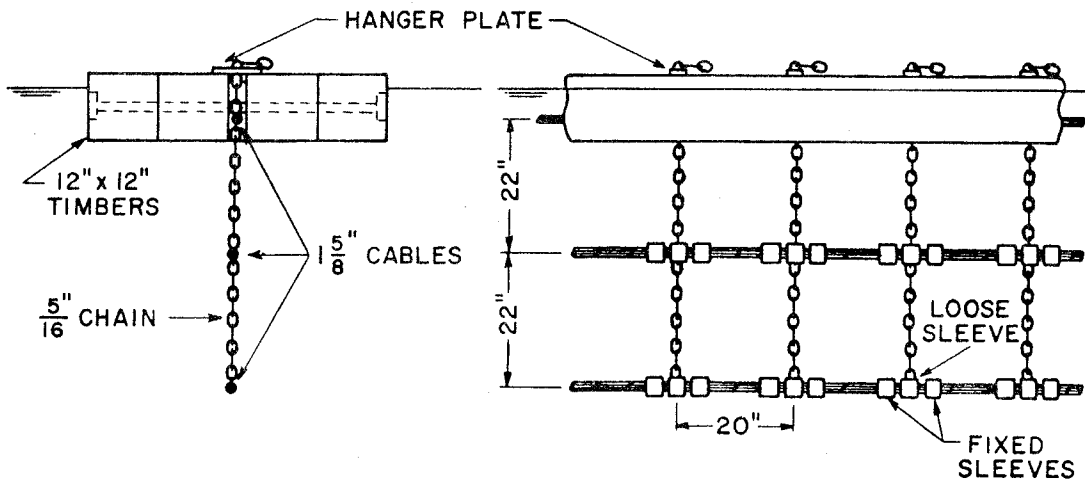

Fig. 15. Light Duty Net Boom



NOTE: All sleeves 1-1/2" long, cut from 2" ϕ pipe. Fixed sleeves pressed on in the field. Hanger chain field-welded to loose sleeves.

Fig. 16. Heavy Duty Net Boom

1000 feet or more. All that is required to transform the bridge into a boom is a continuous line of floats to keep the cables at the surface of the water and help stop the logs, plus cross ties at say 2 feet intervals to maintain the spacing.

If such a boom must be opened to pass wood downstream, two small barges and some winch gear would be needed as part of the system. However, neither the boom itself, nor the operating gear appears to be difficult to design, and in deep water the cost would likely be less than that of piers plus a heavy duty deep boom.

(c) Types of Towing Boom

(i) Round boom

A double string of small round boom sticks is often used for light towing jobs, while a double string of big Sitka spruce boom sticks is satisfactory even for work on Lake Superior.

(ii) Deep boom

In eastern Canada, core boom is used extensively and a double string of heavy core boom sticks has been effective even where there is considerable wave action. Laboratory tests [below, section (e)] show that in calm water the wood retention would be improved if longer stringers were used. When severe wave action is encountered, laboratory tests reported by Kennedy¹⁰⁾ showed that a core boom with stringers extending nearly to the end of the core (Fig. 37 and Table 2, Type c-3) permitted losses only one quarter as large as those which occurred with the conventional core boom (Fig. 22, Designs #9 and 10, and Table 2, Type c-2).

Still heavier designs of deep boom are used at times but (as previously shown¹⁰⁾ better results would probably be obtained with a strong lightweight boom (see Table 2, Type c-4).

(d) Types of Glance Boom

There are three main types of Glance or Guide booms used to divert the floating logs across the current and into the desired channel.

(i) Flat boom

This boom, which may be from two to four timbers wide, works very well where the angle of diversion and the current velocity are not too great. Fig. 17 shows such a boom which is held in position by the thrust of the current against its pole fins projecting on the downstream side. Since it is tied to only one bank, a boom without fins would be thrust by the current into the shore.

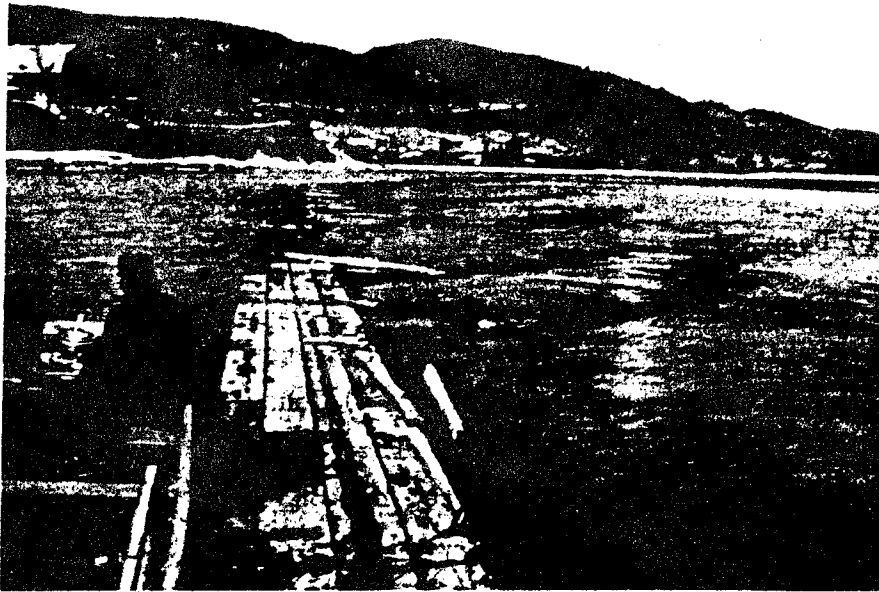

Fig. 17. A Glance Boom Maintained in Position by Pole Fins

(ii) Flat boom with vertical lip

The capability of the boom to direct logs is increased when a vertical plank or an additional piece of timber is added to the bottom of the upstream face of the glance boom as shown lower left in Fig. 13c.

(iii) Flat boom with horizontal lip

A better performance is also obtained if a horizontal lip is added at the bottom of the upstream face as shown in Fig. 32. The effect of this horizontal obstruction is to reduce the undertow which results from the stream current plunging under the boom and thus to reduce the number of low-floating logs lost under the boom.

In difficult situations the performance has also been improved by a smooth metal sheathing on the upstream face. The performance of glance booms of various shapes is investigated in the succeeding sections.

(e) Laboratory Tests and Results

The proper evaluation of alternative designs of boom for a particular employment requires a knowledge of the following items.

1. The strength of the boom stick in bending and in tension and the strength of the connections between sticks.
2. The durability of the boom stick - that is, its resistance to abrasion, rot and loss of buoyancy.
3. The wood-stopping ability of the boom stick.

The first two items fall within the realm of ordinary engineering and experience. The third item, the rating of wood-stopping ability, is more difficult to evaluate and for this reason a series of hydraulic laboratory tests of scale models of representative boom designs was undertaken.

All tests were carried out using models of 8 inch diameter by 4 foot length pulpwood sticks and various booms (all at a scale of 1:20) in a 3 foot deep by 4 foot wide laboratory channel. The velocities in the channel were varied up to 1.2 fps which is the equivalent of a velocity of 5.35 fps in the field.

Because eddies, waves, winds and the specific gravity of the floating wood, as well as that of the boom sticks, influence results in the field, it is not intended that the laboratory results, measuring effects of current only, should be used to predict quantitatively the number of sticks which would escape under certain conditions in the field. However, since each model boom was tested under exactly the same conditions as the others in the laboratory, it is believed that the booms which performed best in the laboratory would also perform best in the field.

(i) Tests of wood stopping performance of holding booms

For each test 11.00 pounds, approximately 1375 model logs, were introduced gradually into a long straight stretch of the channel at a distance of 18 feet upstream from the test boom, a typical example of which may be seen in Fig. 18. Logs which escaped past the boom were caught by a screen which covered the entire cross section of the channel a few feet downstream.

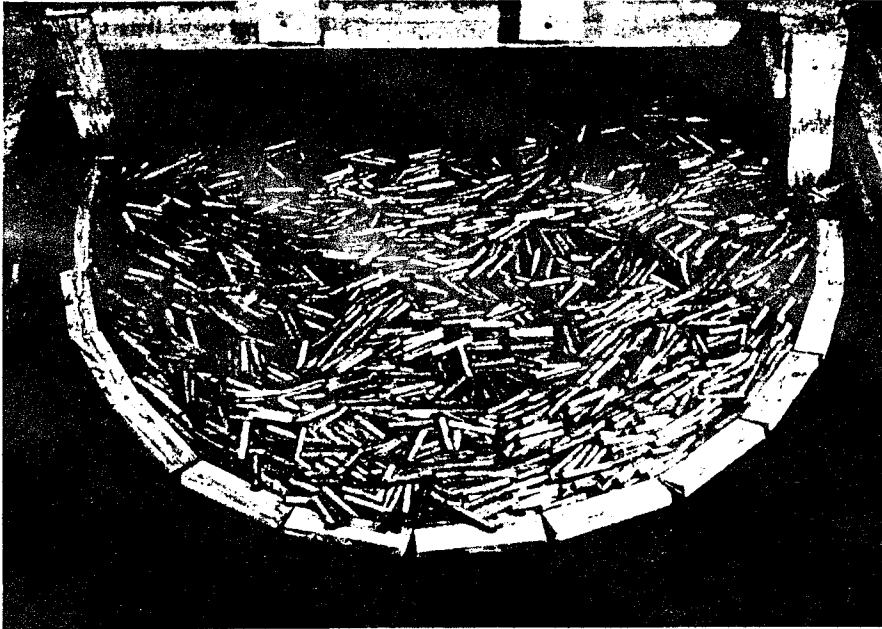

Fig. 18. Test of a Holding Boom in the Laboratory

After a few minutes, when the jam had stabilized, those logs which had escaped were recovered, weighed, and the per cent of logs escaping was recorded.

In order to maintain the same specific gravity for each test, the varnished hardwood logs were taken out of service and dried after no more than 5 test runs, a maximum of 50 minutes in the water. The specific gravity of samples of the model logs was checked at intervals and stayed very close to 0.76.

The model boom sticks used in the tests were 1:20 scale with various cross sections (see sketches beginning with Fig. 20) but regularly 6.3 inches long. This model length corresponds to a length of 10.5 feet in the prototype, whereas the actual field lengths are usually 25 feet to 35 feet and occasionally longer.

The use of these relatively short sticks permitted a realistic boom alignment in the 4 feet wide channel where the control of water velocity was easy, and tests could be carried out with as few as 1375 logs at a time. The short boom sticks did intensify the loss of wood at the junction between adjacent boom sticks as contrasted with losses over or under the boom.

Since the purpose of the tests was to evaluate the effectiveness in stopping wood of one boom design relative to another, it is felt that the technique adopted was adequate.

Fig. 19 shows the end of a test of a flat boom in a current velocity slightly greater than that which it could withstand satisfactorily. Most of the logs have been retained but a number are on top of the boom or are caught in the eddy at its downstream edge. Others have escaped and are resting on the screen which is not visible in the photograph.

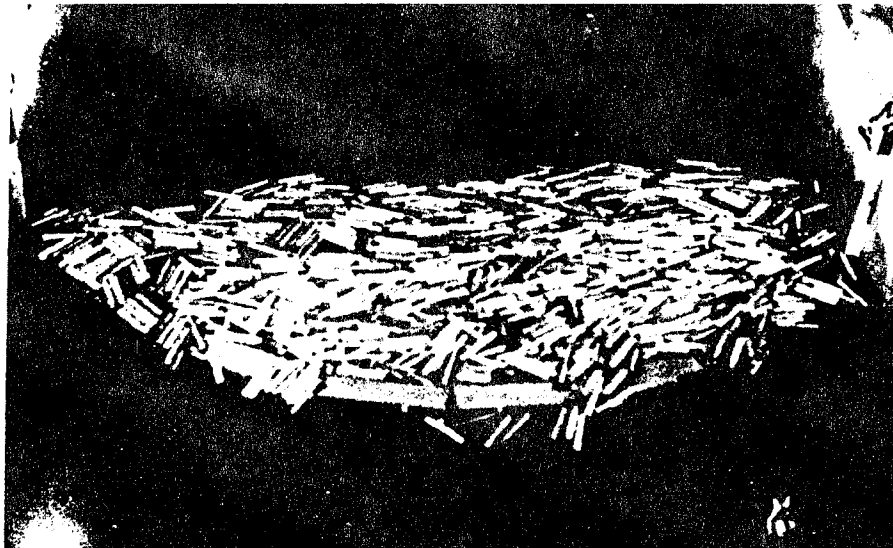

Fig. 19. Test of the Stopping Power of a Flat Boom

In the pages that follow, perspective sketches of the different boom sticks are shown to the right of scale cross sections of the boom sticks tested. A plot of the percentage of logs lost vs surface velocity in the centre of the channel appears either below each group of boom sticks or on the following figure. The percentage of logs lost at a particular velocity is an indication of the holding ability of each boom relative to the others.

ROUND BOOMS

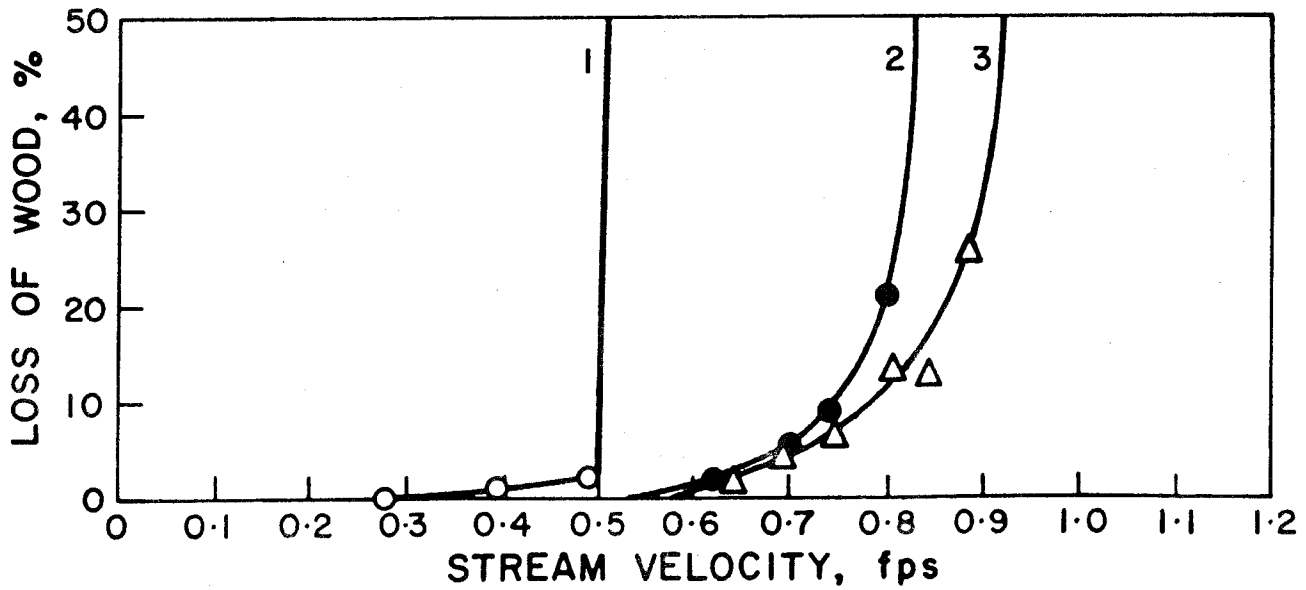
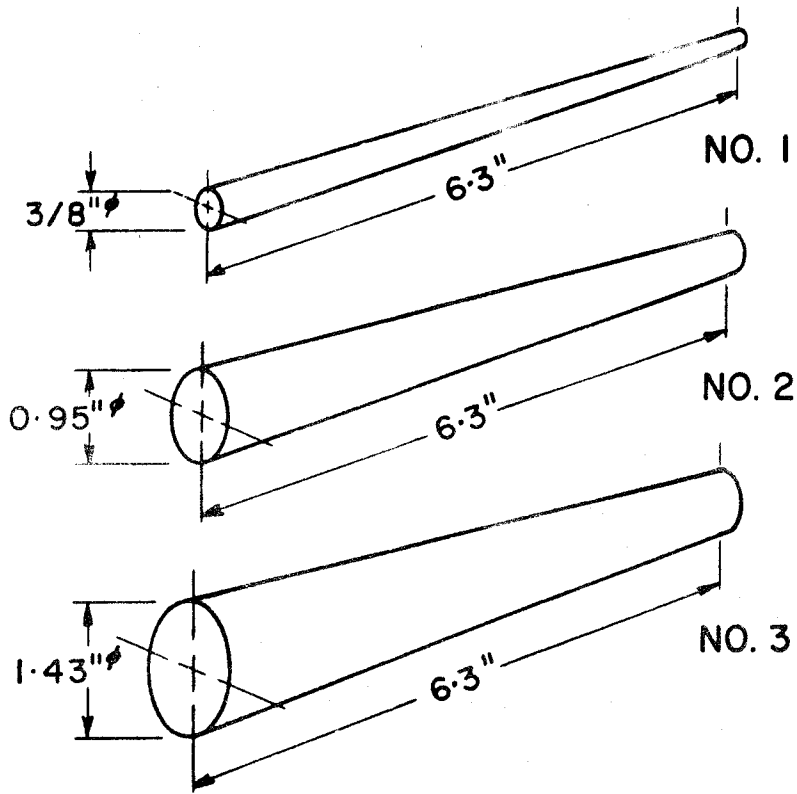

Fig. 20. Laboratory Tests of Round Holding Booms

FLAT BOOMS

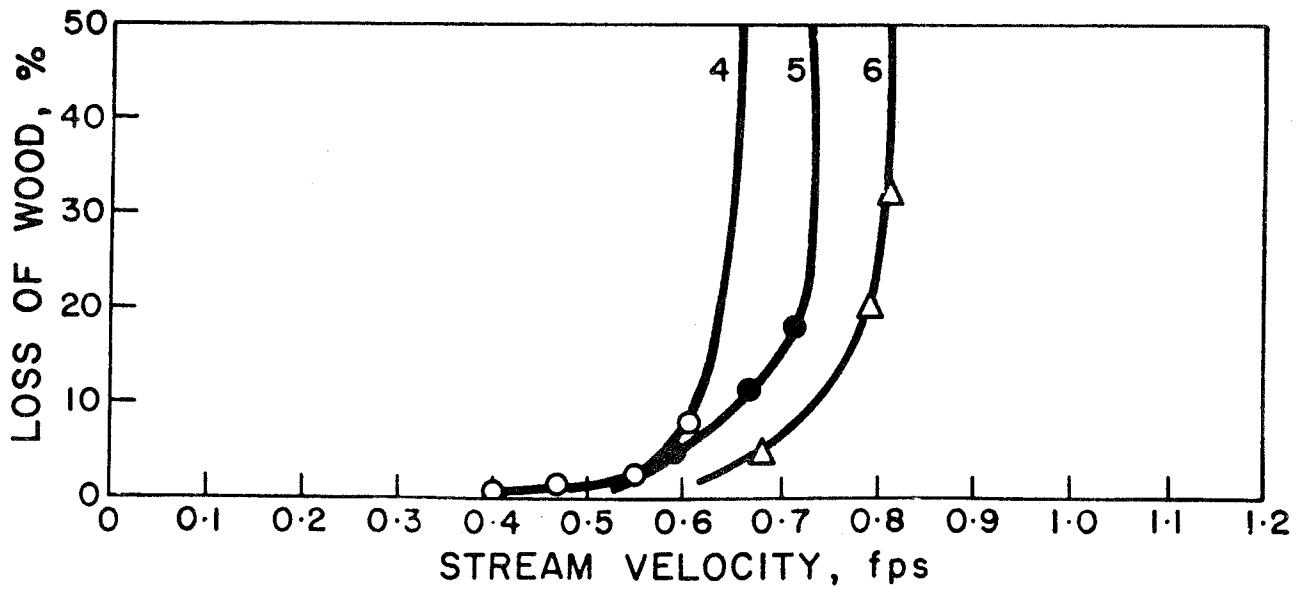
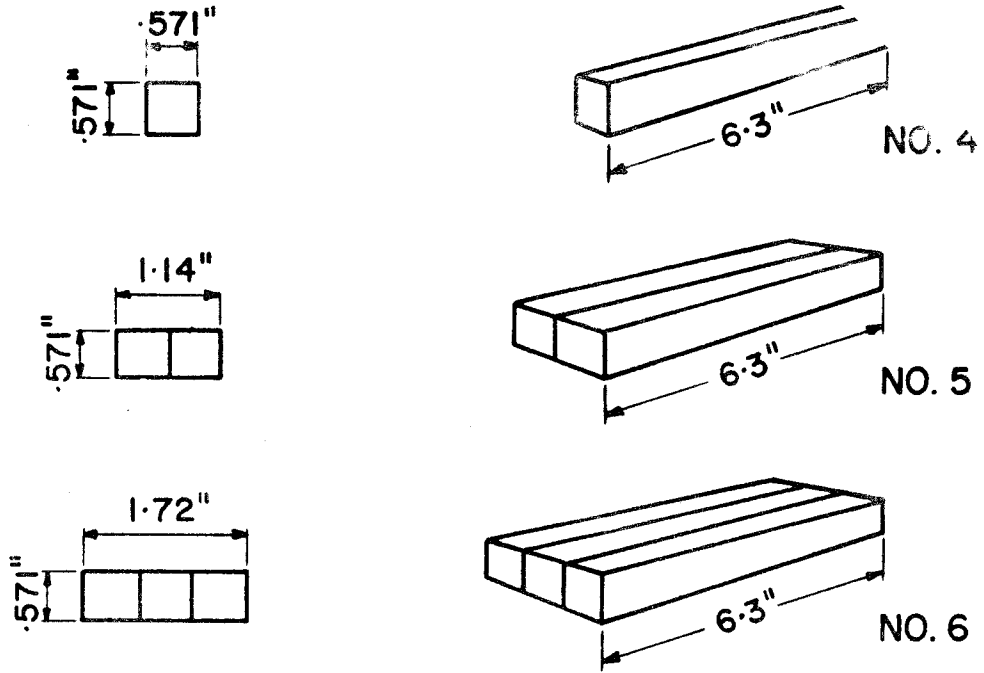
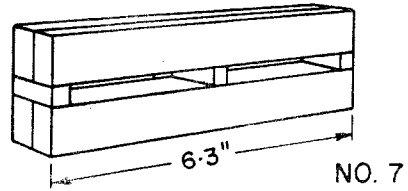
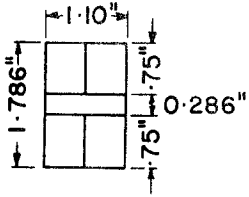

Fig. 21. Laboratory Tests of Flat Holding Booms

DEEP BOOMS

NARROW DOUBLE TIER



WIDE DOUBLE TIER

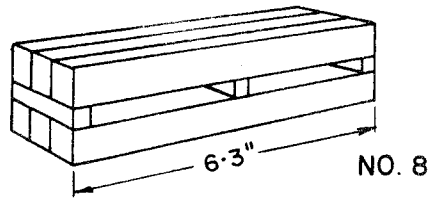
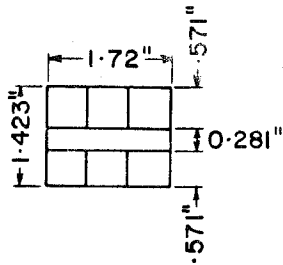

BATHURST BOOM

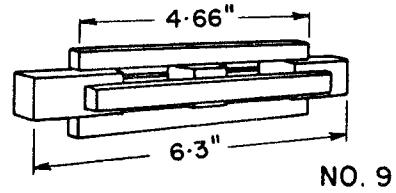
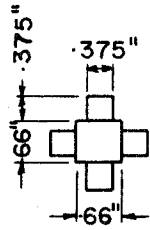

BATHURST BOOM

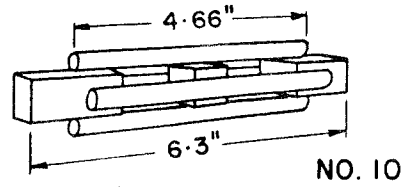
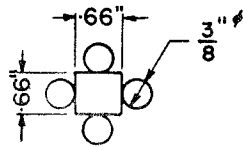
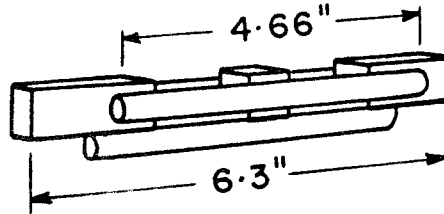
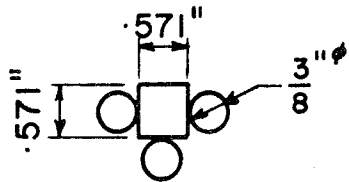

Fig. 22. Designs of Deep Holding Booms

KEEL BOOM



NO. 11

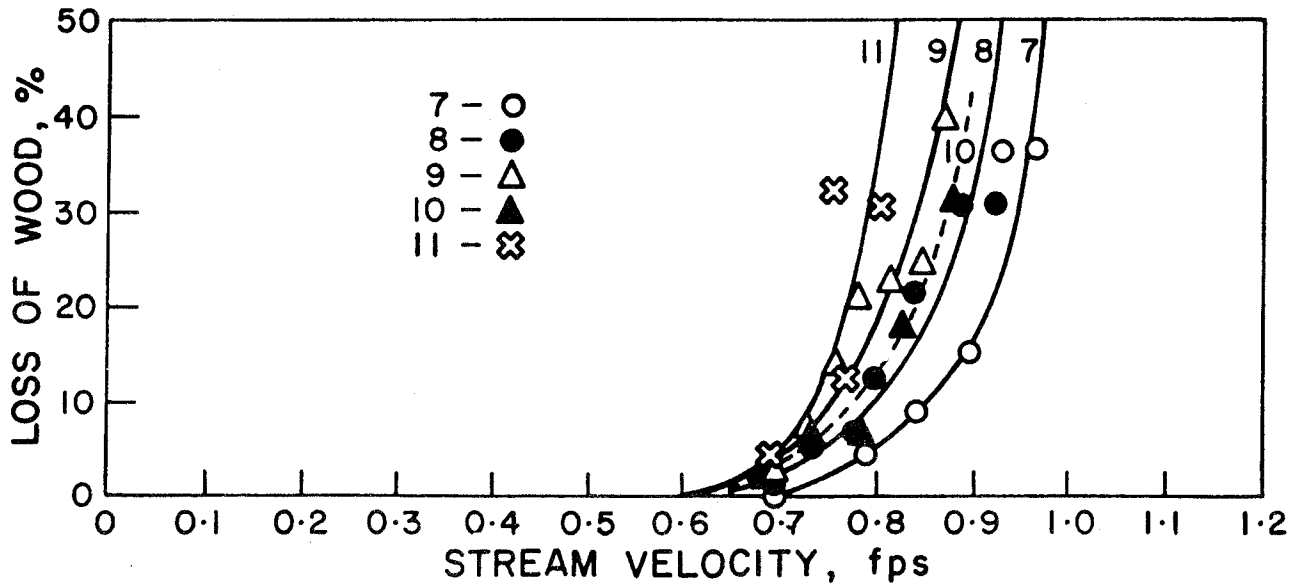

Fig. 23. Design of Keel Boom and Laboratory Tests of Deep Holding Booms

FENCE BOOMS

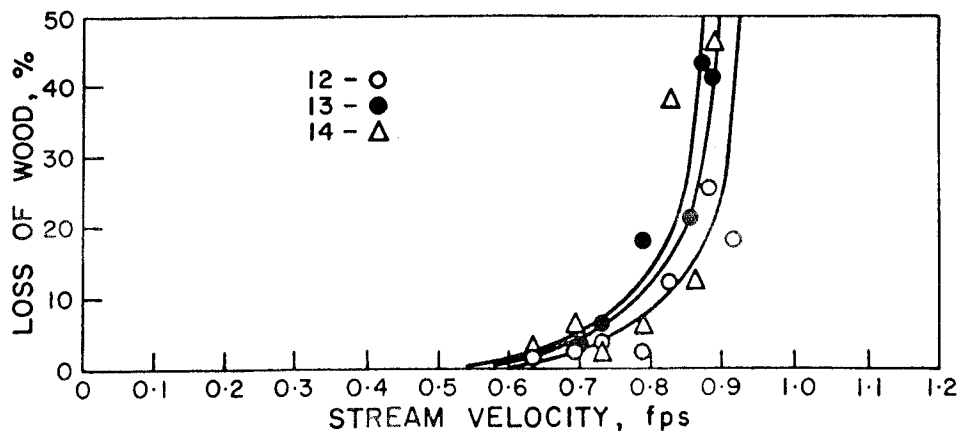
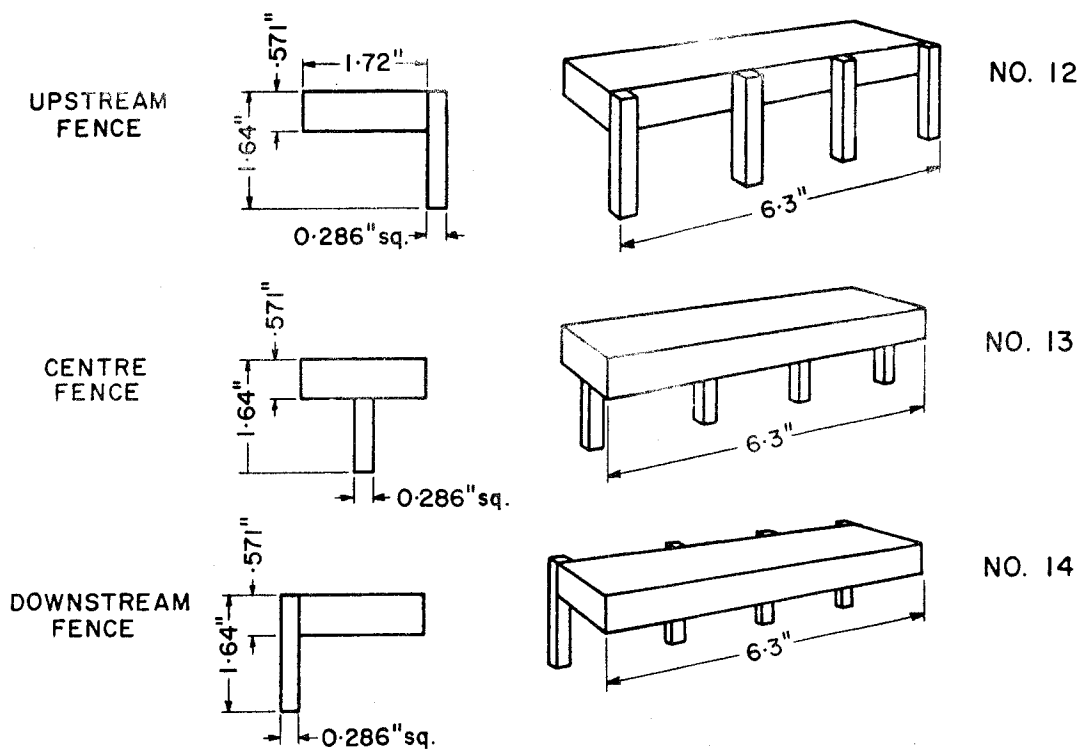

Fig. 24. Laboratory Tests of Fence Holding Booms

NET BOOMS

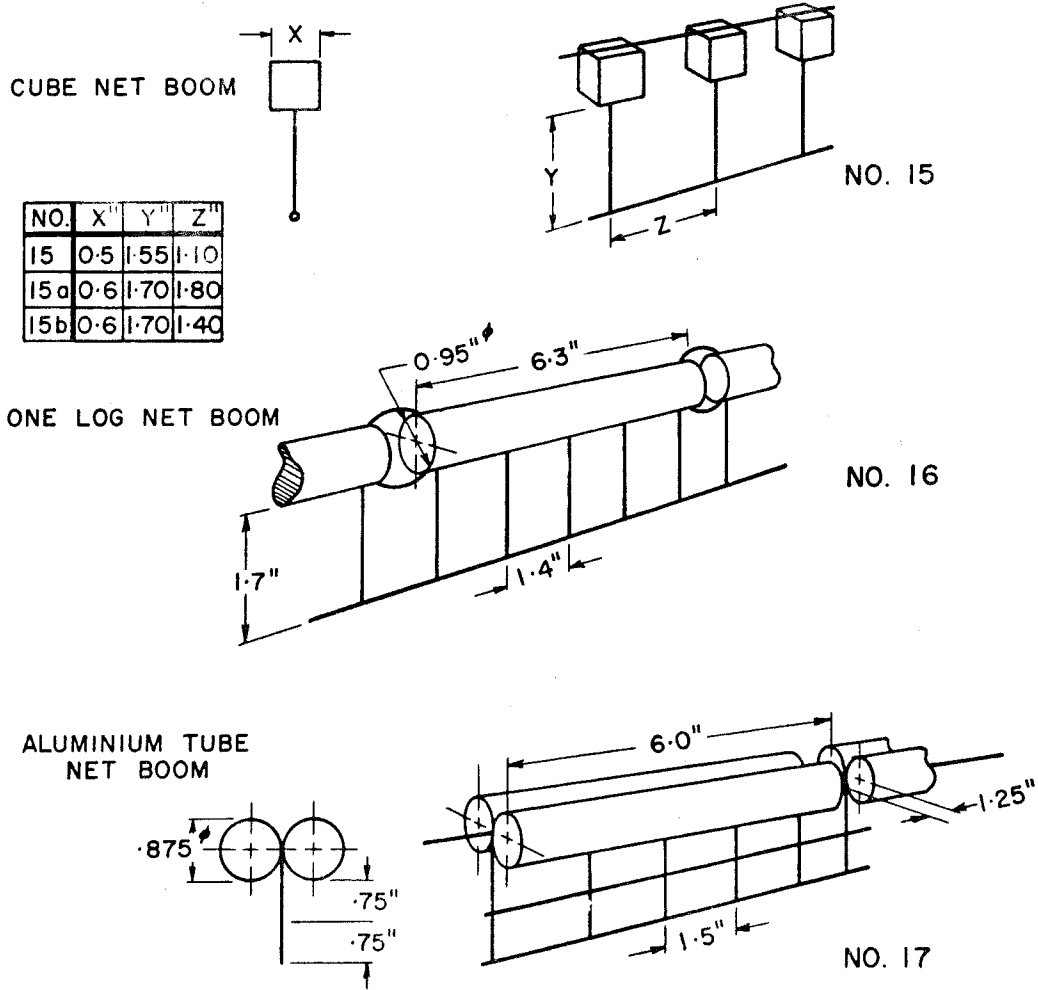

Fig. 25. Trial Designs of Net Booms

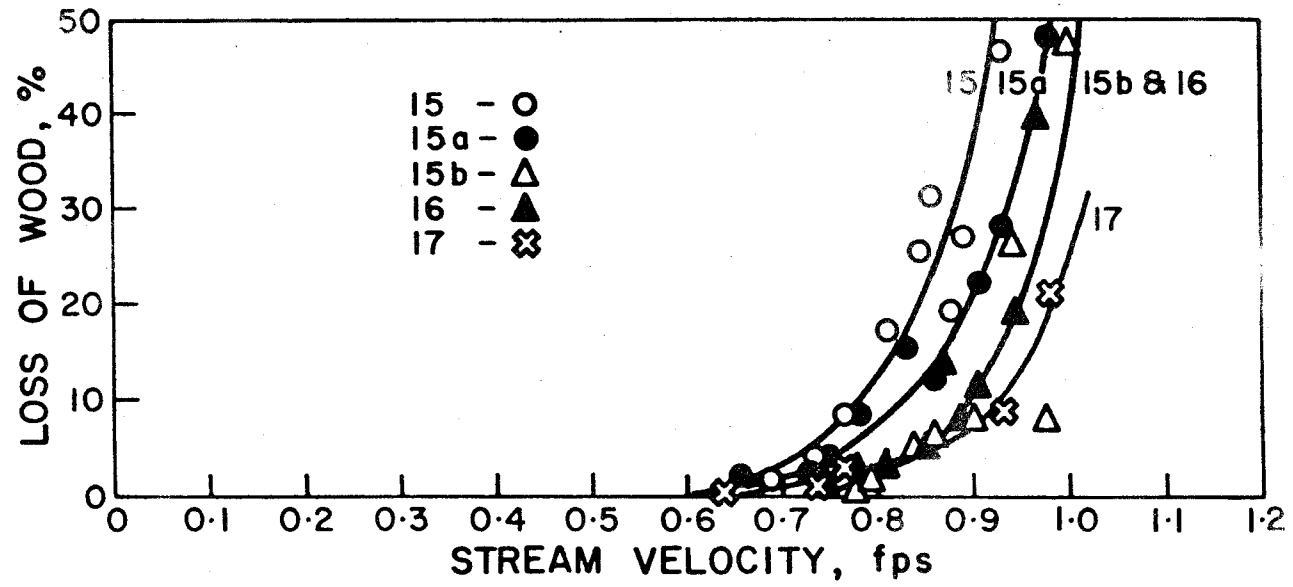
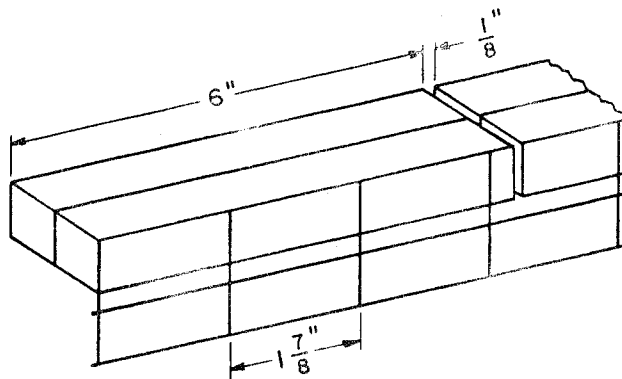
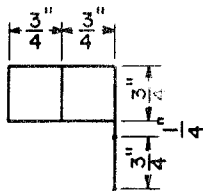
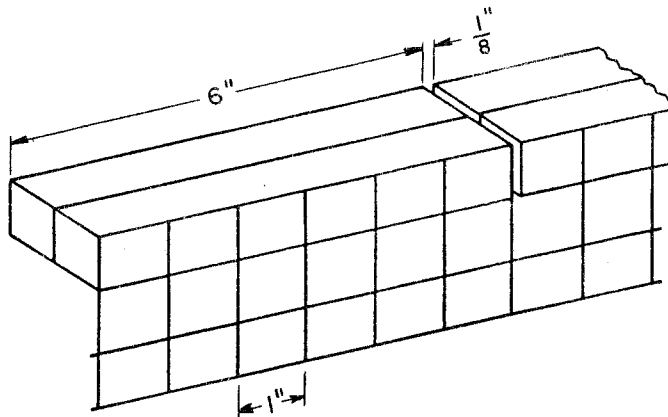
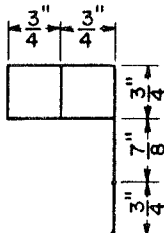

Fig. 26. Laboratory Tests of Trial Designs of Net Booms

BOOM TYPE NO. 18
11 FLOATERS



BOOM TYPE NO. 19
13 FLOATERS



BOOM TYPE NO. 20
13 FLOATERS

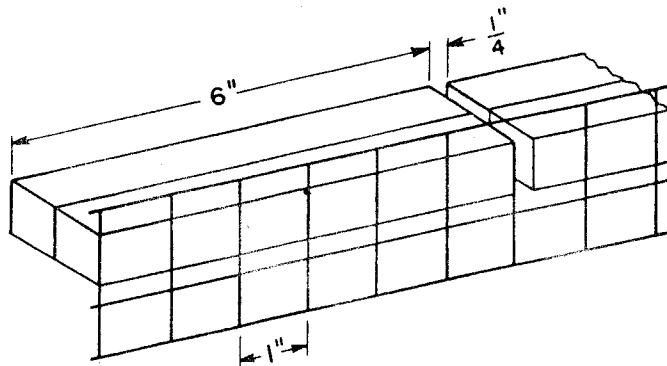
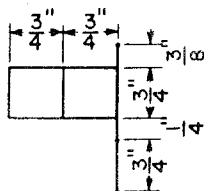

Fig. 27. Dimensions of Model Net Booms Nos. 18, 19 and 20

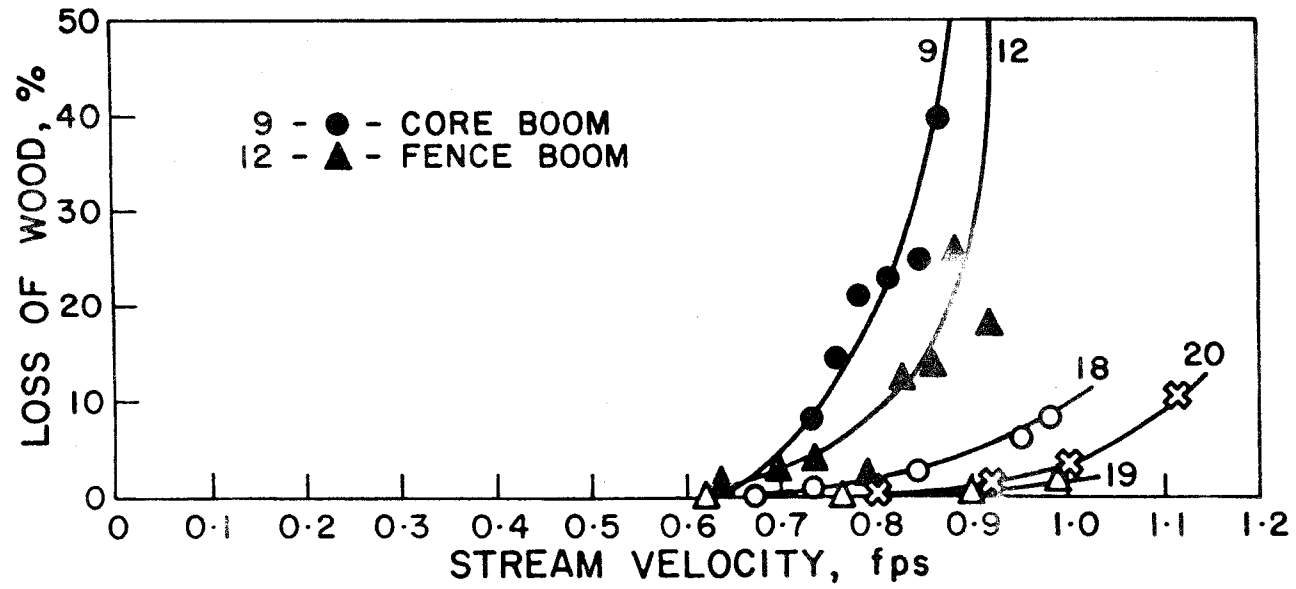

Fig. 28. Laboratory Tests of Net Booms (Data for Core and Fence Boom Shown for Comparison)

Fig. 28 shows the performance of three of the latest designs (Fig. 27) of net booms together with curves for a typical core boom and a fence boom.

It can be seen from the sketches in Fig. 27 that the bottoms of net numbers 18 and 20 extend to only 1-3/4 inches below the top of the floaters (corresponding to a depth of about 3 feet in the field) while that of number 19 extends to 2-3/8 inches (about 4 feet in the field). This proved to be important since at the higher velocities this jam was deeper than the shallower nets of number 18 and 20, and wood was lost under the bottom of the net. Net boom number 19 had the greatest stopping ability of any holding boom tested. Other deep booms, such as the Bathurst type number 9 and fence boom number 12, were definitely less efficient at the high velocities.

As stated at the beginning of this section, these tests evaluate the wood-stopping ability of the different designs of boom only against current. The performance of model booms in waves was reported in the preceding report in this series¹⁰⁾ and is summarized below in Table 2 in the section on "Towing Booms". Similar model tests were not carried out to show the effect of wind, but wind forces acting on towed rafts in the field were reported from an earlier study⁸⁾. The other important characteristics of booms, such as strength and durability, must be assessed by the usual engineering methods.

(ii) The wood stopping capacity of a pulpwood jam.

It is known that in the field when a substantial jam has formed, additional sticks are stopped by the jam itself, the boom being called upon only for its strength.

This phenomenon was duplicated in the laboratory when baskets of logs were fed down to deep boom No. 7 at a velocity of 0.96 fps. Fig. 29 shows how the percentage loss for successive batches of logs decreased until, after about 9600 logs had been floated into the holding ground in the 4 feet wide channel, no more were lost.

This test confirmed the opinion that the capacity of a holding boom to stop floating logs is vitally important while the jam is being formed, but is of lesser importance thereafter.

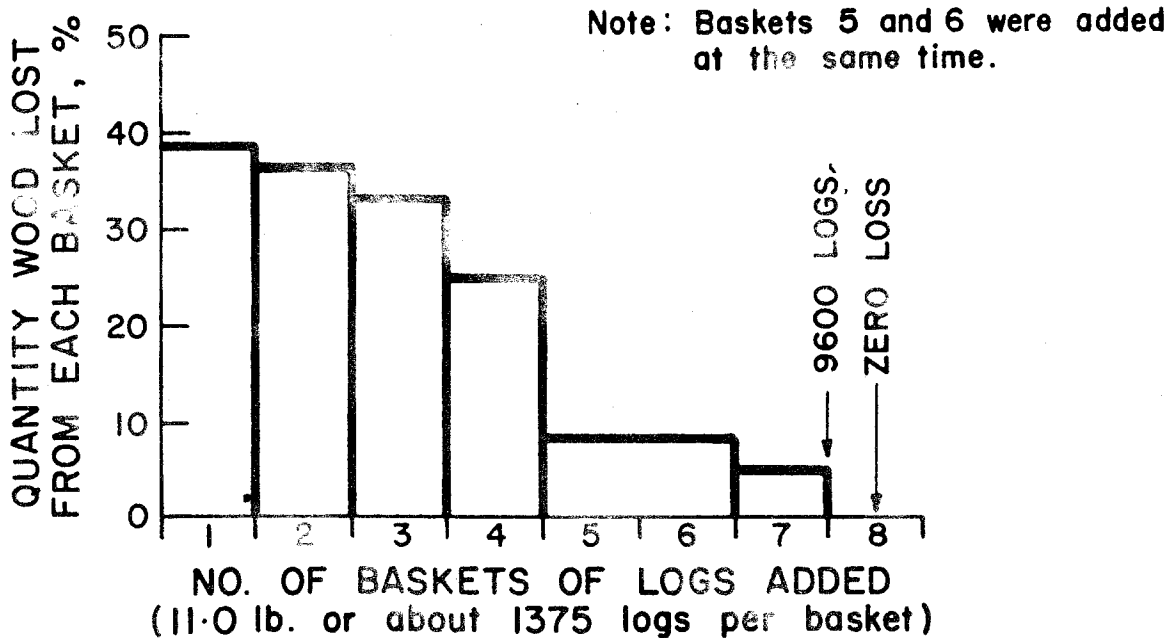

Fig. 29. The Wood Stopping Capacity of a Pulpwood Jam

(iii) Towing booms

The characteristics required by a good towing boom are similar to those required by a holding boom except that there is usually an increased possibility of wave action and the jam does not become set to the same extent. No tests of towing booms as such were carried out, but the results of tests of the holding power of booms in waves, which were reported earlier¹⁰⁾, are discussed in section (f) of this chapter and some conclusions regarding towing booms are drawn.

(iv) Glance or guide booms

Glance or guide booms, used to guide floating pulpwood away from obstacles and towards desired channels or areas, rarely encounter severe conditions of wind or waves. The two most important variables involved in their design are the angle which the boom makes with the current and the velocity of the current.

A number of different glance booms were tested in the same channel in which the holding boom tests had been carried out. The essential parts of the testing device are shown in Figs. 30 and 31. The logs were introduced upstream of the glance boom in such a position that most of them struck the boom. The percentage of logs which escaped was computed from the ratio of the number of logs

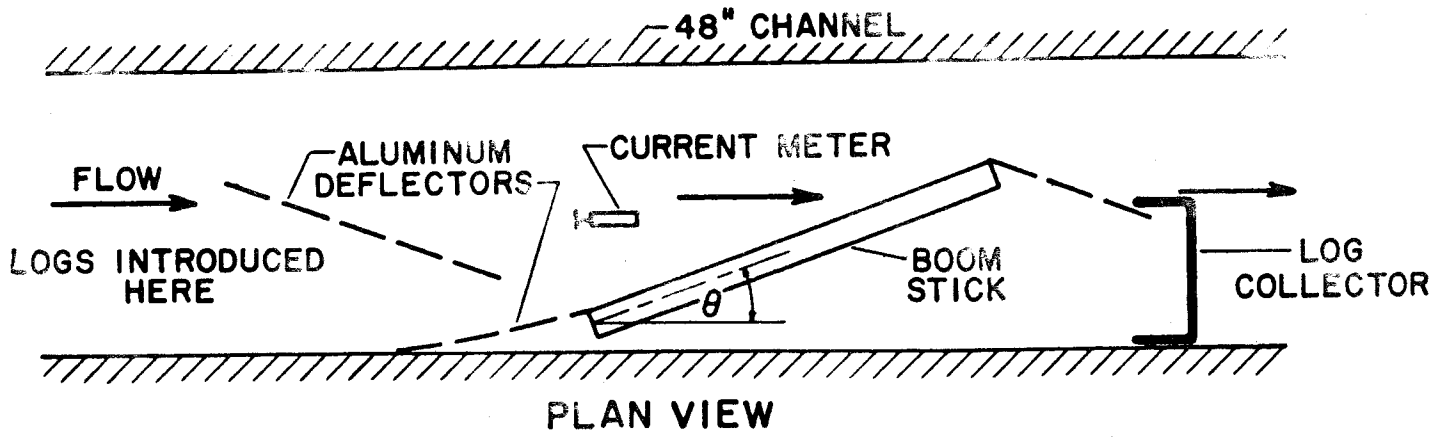

Fig. 30. Apparatus for Test of a Glance Boom

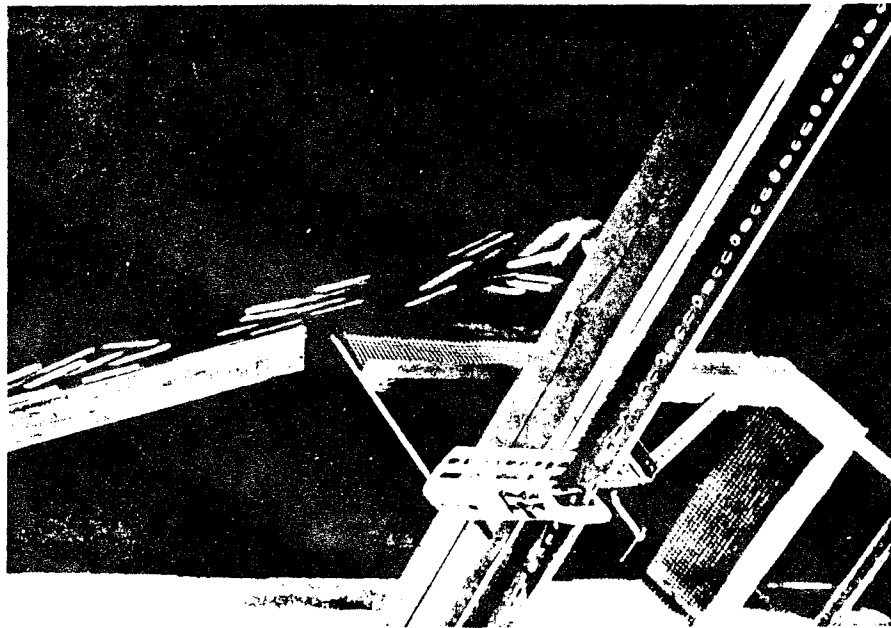

Fig. 31. Test of a Glance Boom

that passed under the boom to the number which actually reached the glance boom. This ratio was measured for various current velocities and for differing values of the angle, θ . Again, all tests were comparative and no attempt was made to scale up the results of the model tests for field application.

The ability of a glance boom to turn logs is affected by the undertow of the current and by the coefficient of friction between the logs and the boom face. It was known from field experience that a horizontal lip projecting upstream at the bottom surface of the boom stick would reduce the undertow and that metal sheathing along the face would reduce the coefficient of friction between the logs and the face.

Since surface tension, which is negligible in the field, tends to create the same effect as an increase in the coefficient of friction in the model, it was decided to sheath the face of each model boom stick with metal. At low velocities it was also necessary to use model pulpwood logs previously immersed in soap solution in order to reduce the effects of surface tension.

Each boom stick was painted to reduce its absorption and then weighted until its specific gravity was 0.75.

Boom sticks numbered 21, 22 and 23 were tested at a velocity of 1.1 fps and at various angles with the results shown in Fig. 32. Number 22, with the medium width lip, gave the best performance. Similar series of tests were carried out at velocities of 0.79 fps and 0.67 fps.

Fig. 33 shows clearly that at the lower velocity of 0.79 fps booms 21 and 22 were capable of guiding logs at a greater angle to the current than at the higher velocity. With still lower velocities satisfactory performance could be obtained with even larger values of θ .

Since the ranking of the different boom sticks with respect to logs lost remained constant at different velocities, it was concluded that tests carried out at anywhere in this velocity range would be satisfactory for comparison of the performance of different designs.

The data from the initial series of tests (Fig. 32) indicated that at a given velocity (1.1 fps in this case) a plain boom started to lose many logs when the angle θ exceeded about 22 degrees, while a boom with a small lip at the bottom would perform reasonably well when set at angles up to 27 degrees.

GLANCE BOOMS

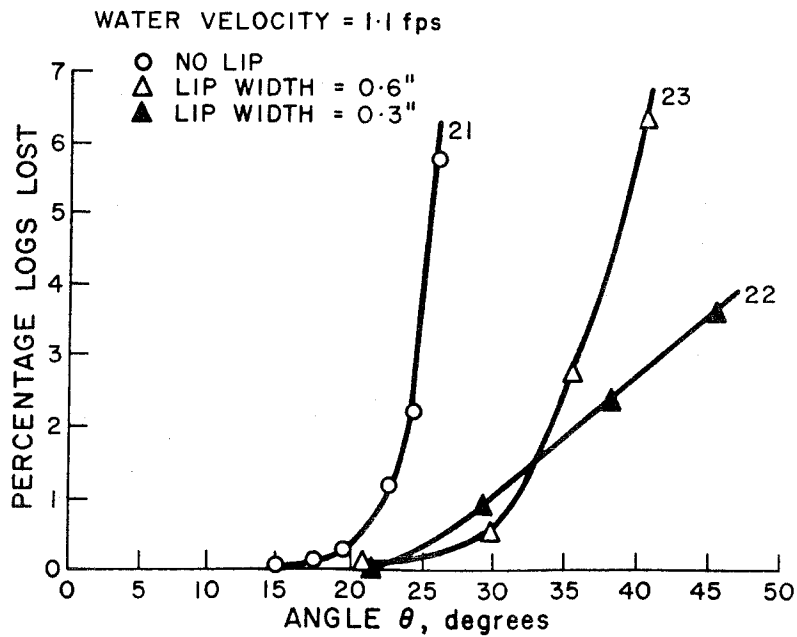
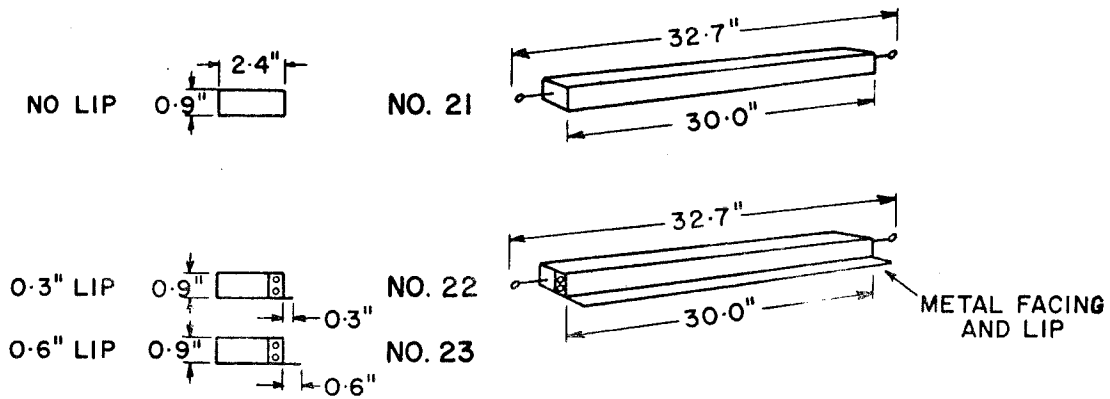

Fig. 32. Results for Glance Booms at Various Angles to the Current

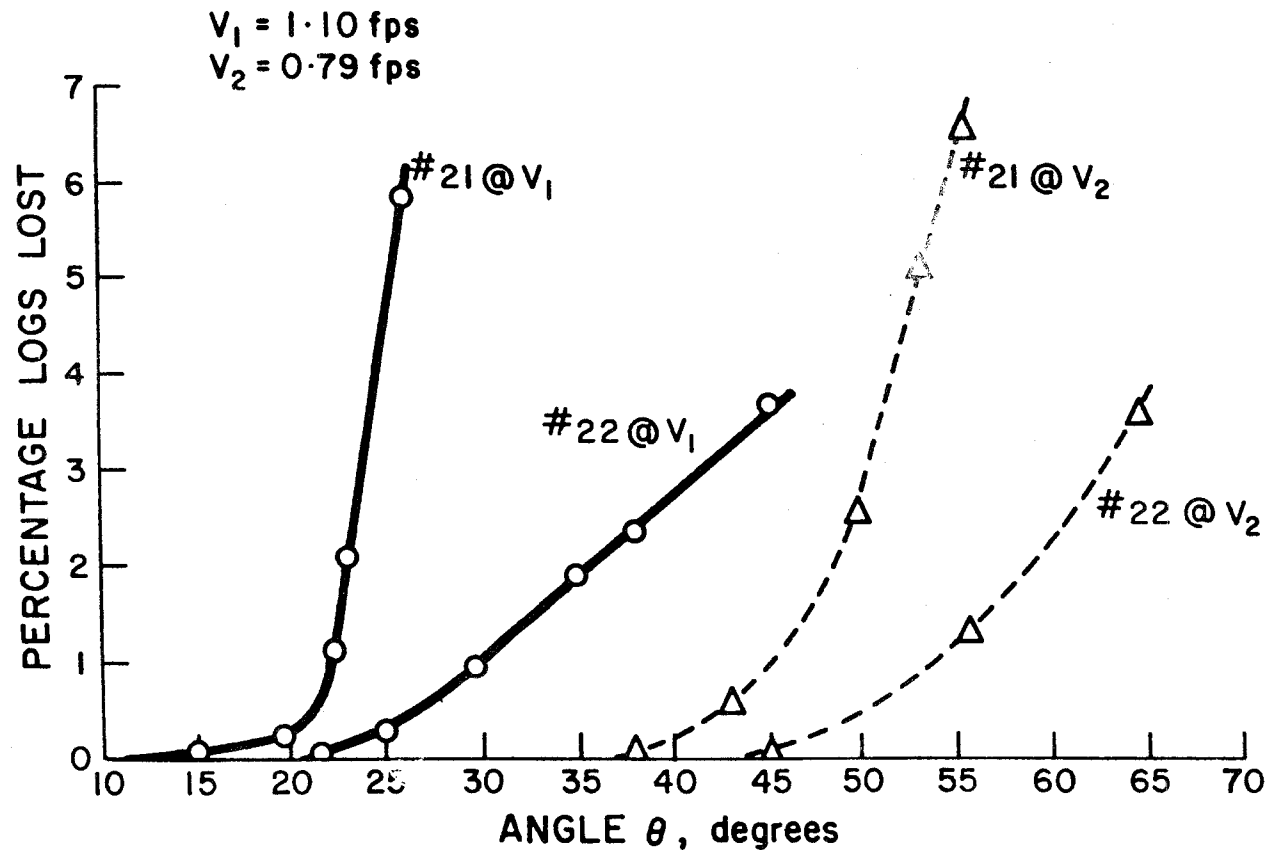

Fig. 33. The Effect of Velocity on the Performance of Glance Booms at Various Angles to the Current

In order to obtain some indication of the limiting conditions for the operation of a glance boom, several hundred test runs were made, using different boom sticks under various conditions. The effect of widening the lip and placing it deeper in the water was investigated in detail.

The maximum angle, θ , at which the logs could be made to flow down beside any laboratory boom was 59 degrees. This is probably far beyond the limit of satisfactory operation in the field.

Fig. 34 shows the effect of variations of the width of the lip and the depth of the lip on performance at an angle of 56 degrees and velocity of 0.92 fps (equivalent to 4.1 fps in the field). It is apparent from both graphs that increasing the width of the lip produces little improvement while increasing the depth of the lip is quite effective. While the depths shown in Fig. 34 are measured below the bottom of the boom stick for convenience it is of course the depth below the surface of the water that is pertinent to the performance.

In assessing the significance of these tests it should be remembered that, to be satisfactory, a field installation should have almost zero loss when handling logs which vary over a considerable range in size, specific gravity and roughness. If all variables in the field were exactly scaled up from the laboratory, then in theory the performance in the field should be considerably better because of the higher ratio of buoyant force to viscous drag. When evaluating the model results, then, it is necessary to recognize that field conditions are far from uniform, that wind waves and current eddies must be added to the variables considered in the laboratory, and that something approaching a perfect performance is required.

Two facts have been established beyond question.

1. The horizontal lip is a very substantial improvement.
2. The upstream face of the boom should be as smooth and continuous as possible.

The first of these facts is substantiated by Figs. 32, 33 and 34; the second, by numerous observations in the laboratory. When logs slow up on the boom because of friction with the face or an uneven joint between boom sticks, other logs push against them and the undertow often rolls some of them under. Once started down in the grip of the current, they are likely to continue underneath the boom and escape. The only solution seems to be a smooth continuous boom face which guides the logs past without slowing them down.

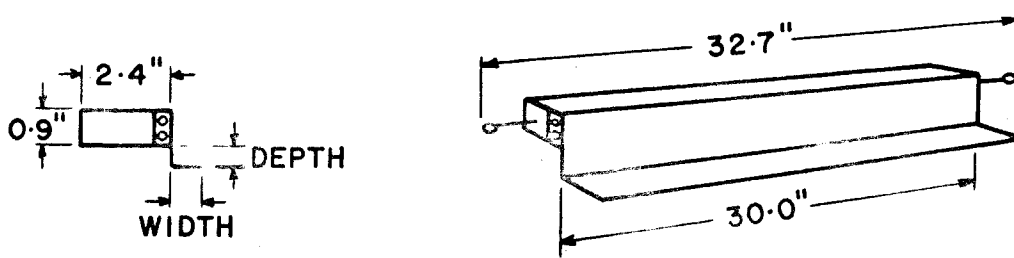

$\theta = 56^\circ$
 $v = 0.92 \text{ fps}$

- LIP DEPTH = 0.9"
- △ LIP DEPTH = 0.6"
- ▲ LIP DEPTH = 0.3"

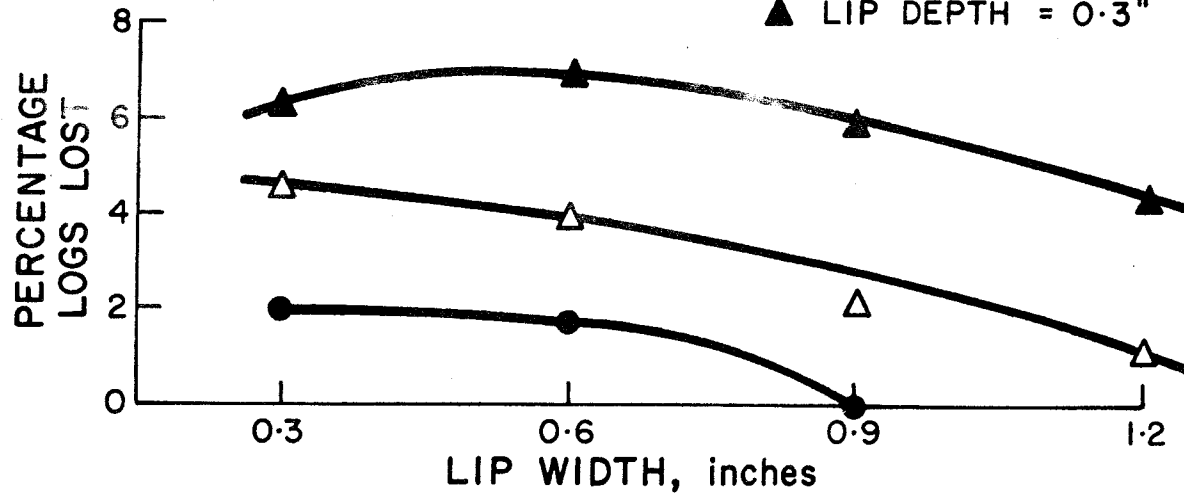

$\theta = 56^\circ$
 $v = 0.92 \text{ fps}$

- LIP WIDTH = 1.2"
- LIP WIDTH = 0.9"
- △ LIP WIDTH = 0.6"
- ▲ LIP WIDTH = 0.3"

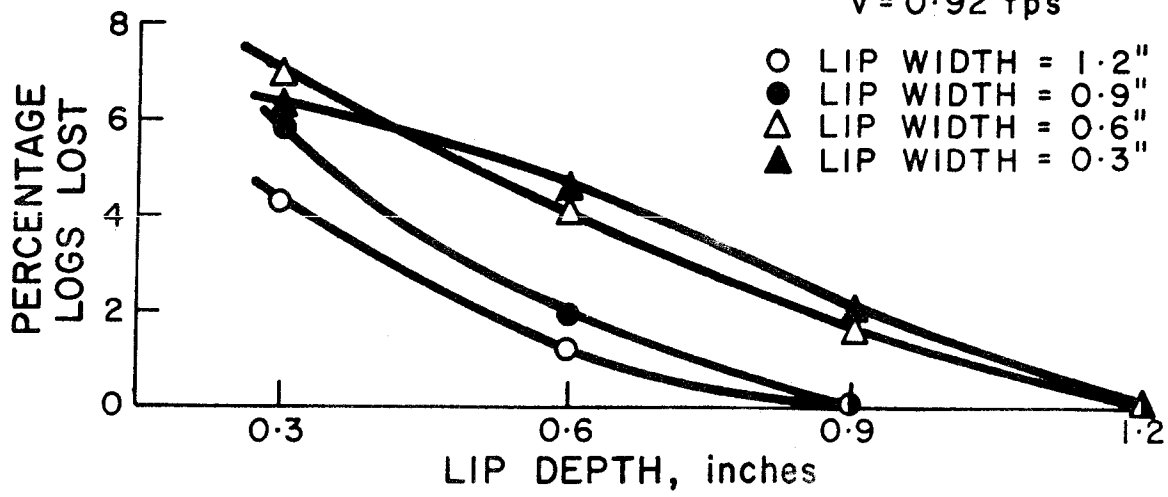

Fig. 34. The Effect of Variations in Lip Width and Depth in the Performance of Glance Booms

When a lip is used at depth, a substantial overturning moment is applied to the boom stick. This may be overcome by means of an outrigger as shown in Fig. 35. For best performance it is important to keep the front face of the boom sticks vertical.

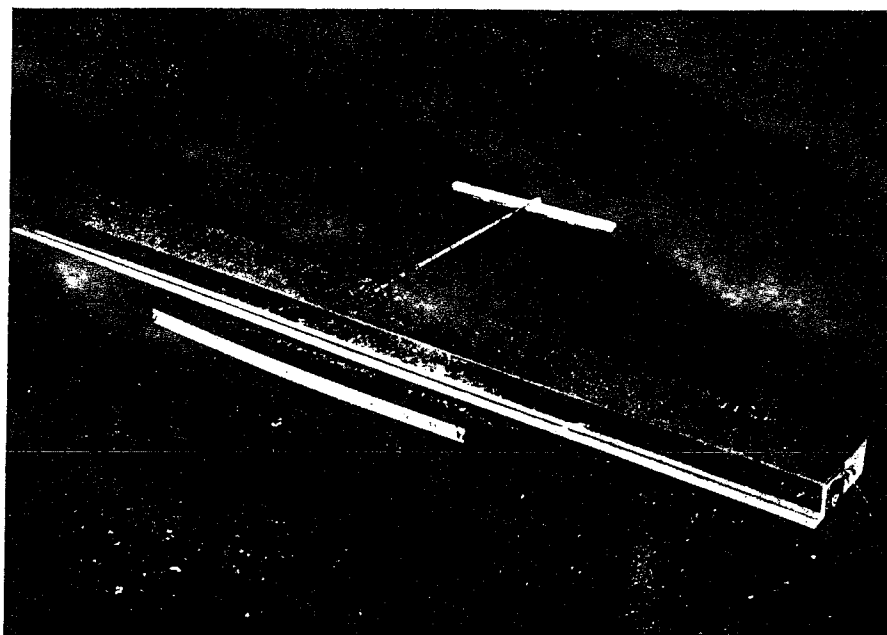

Fig. 35. Glance Boom Stick with Lip and Outrigger

(f) Summary and Recommendations

(i) Holding booms

The current velocities at which each of the model booms stopped all except 1%, 5% and 10%, respectively, of the first wood arriving in the tests were read appropriately from Figs. 20 to 28 and were converted to estimated equivalent field velocity by multiplying by the velocity scale factor, 4.46. These results are shown in Table 1, with the various model booms listed in descending order of wood stopping ability. The type, overall nominal width, depth, and where appropriate, height above the top of the main floating member are shown for comparison.

Table I Velocities at which the Model Booms Stopped 90 to 99% of the Wood

| Boom No. | Type | Approx. Overall Field Dimensions - in. | | | Loss of Logs: | | | Service Rating |
|----------|-------|--|--------|---------|-------------------|-------------------|--------------|----------------|
| | | Width* | Depth* | Height* | 1% Field Velocity | 5% Velocity - fps | 10% Velocity | |
| 19 | Net | 30 | 40 | 0 | 4.0 | 4.9 | 4.9 | S-1 |
| 20 | Net | 30 | 35 | 8 | 4.0 | 4.6 | 4.9 | S-2 |
| 18 | Net | 30 | 35 | 0 | 3.3 | 4.1 | 4.5 | |
| 16 | Net | 19 | 53 | 0 | 3.4 | 3.8 | 4.0 | |
| 15b | Net | 12 | 46 | 0 | 3.4 | 3.8 | 4.0 | |
| 17 | Net | 35 | 48 | 0 | 3.2 | 3.9 | 4.1 | |
| 7 | Deep | 22 | 36 | 0 | 3.2 | 3.6 | 3.8 | S-3 |
| 15a | Net | 12 | 46 | 0 | 3.0 | 3.4 | 3.7 | |
| 8 | Deep | 34 | 29 | 0 | 2.9 | 3.3 | 3.6 | H-1 |
| 12 | Fence | 40 | 33 | 0 | 2.9 | 3.3 | 3.7 | H-2 |
| 10 | Deep | 29 | 29 | 8 | 2.9 | 3.3 | 3.5 | H-3 |
| 15 | Net | 10 | 41 | 0 | 2.9 | 3.3 | 3.5 | |
| 9 | Deep | 29 | 29 | 8 | 2.9 | 3.1 | 3.3 | H-4 |
| 11 | Deep | 26 | 19 | - | 2.8 | 3.1 | 3.3 | H-5 |
| 3 | Round | 29 | 29 | - | 2.7 | 3.2 | 3.5 | H-6 |
| 13 | Fence | 34 | 33 | 0 | 2.7 | 3.2 | 3.5 | H-7 |
| 14 | Fence | 40 | 33 | 0 | 2.6 | 3.1 | 3.4 | H-8 |
| 6 | Flat | 34 | 12 | 0 | 2.6 | 3.0 | 3.3 | H-9 |
| 2 | Round | 19 | 19 | 0 | 2.6 | 3.1 | 3.3 | H-10 |
| 5 | Flat | 23 | 12 | 0 | 2.3 | 2.6 | 2.9 | L-1 |
| 4 | Flat | 12 | 12 | 0 | 2.1 | 2.6 | 2.7 | L-2 |
| 1 | Round | 8 | 8 | 0 | 1.8 | 2.2 | 2.2 | L-3 |

The model test data provide a fairly reliable comparison of the initial stopping ability of the different designs of boom. However, as a field jam lengthens it becomes capable itself of stopping logs and the boom is then required to resist increasing thrust. If the boom is too shallow or too light for the duty, it may be pushed under or ride up over the jam, thus permitting wood to escape. In Table 1 (column headed "Service Rating") the writers have assigned some of the different boom designs that were tested to three classes of service conditions: (S) Severe, where the velocity of the current is between 3 and 4.5 fps, (H) Heavy, where it is between 1.5 and 3 fps, and (L) Light, where it is less than 1.5 fps. Thus booms 19, 20 and 7 are listed for severe duty, booms 8, 12, 10, 9, 11, 3, 13, 14, 6 and 2 are assigned to heavy duty, and booms 5, 4 and 1 are reserved for light duty only.

* Overall dimensions include all members such as stringers and net cables. Depth is vertical distance below, and height, above top of main floating member.

Booms are used under so many different conditions that many designs are justified. For light duty the traditional wooden boomstick, either round or square is likely to be the most economical. Where large forces and deep jams are expected the writers feel that the assured strength of steel cable is desirable. If the cable is used in the form of a three strand "net" the restraining force is applied at about the correct elevation for a deep jam.

Model boom number 19 which had a total depth equivalent to 4 feet, at field scale, showed excellent wood stopping characteristics in calm water but tests of a somewhat similar boom in waves (model d-3¹⁰) resulted in large losses over the top. Under field conditions, even without large waves, it is quite possible that appreciable losses over a low floating boom would occur. It was with this in mind that model boom number 20 with the raised top cable was tested. While number 20 did prevent logs from getting over the top it was apparent that the upper cable was not resisting its share of the load and logs were lost at the bottom. The latter fault could be overcome by proper design but the first could not.

The best solution of all appears to be a net which extends 4 feet below the water surface, supported by floats which extend several inches above the surface. It is recommended that for severe duty net booms be supported by floats which provide a nearly continuous vertical face at least 16 inches high. The specific gravity should be low enough that this face will project at least 4 or 5 inches above the water surface. If possible the floats should be individually removable so that replacements can be made conveniently.

Floats of thin-walled metal tubing are a possibility, but these do not provide the desired vertical face for initial stopping of pulpwood in fast water and are somewhat susceptible to puncture. One alternative is a sturdy wooden box filled with styrofoam or equivalent for continued buoyancy. An idea of the possible appearance of such a device is given in Fig. 36.

(ii) Towing booms

Wave action is a factor in most towing booms as well as with some holding booms. The holding performance of some model booms in waves was described in the second report¹⁰ in this series and a summary of the results is presented in Table 2. Obviously some of these booms, such as the double string of large Sitka spruce round booms (a-3 in Table 2) are easy to handle in towing operations and are quite effective in waves.

STYROFOAM OR
EQUIVALENT - PRODUCED
IN TIMBER SIZES AT
ABOUT \$100/M bd. ft.
WEIGHT $\approx 1.0 \text{ lb./ft.}^3$

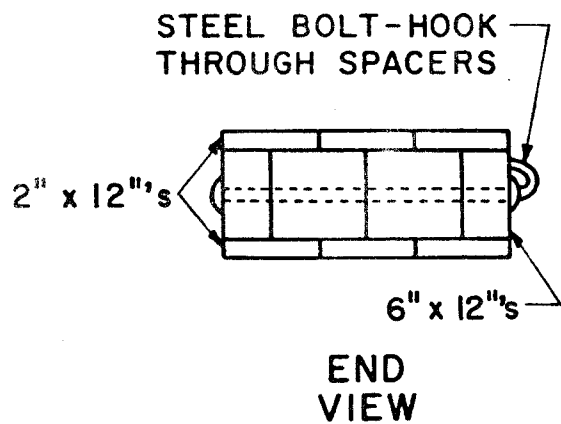

PLAN VIEW

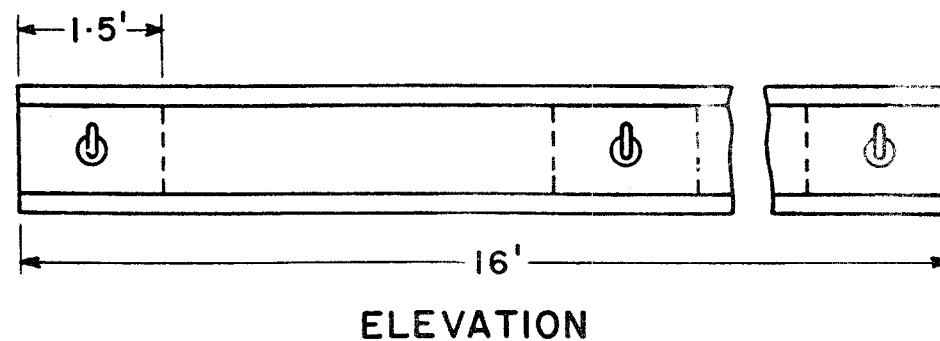
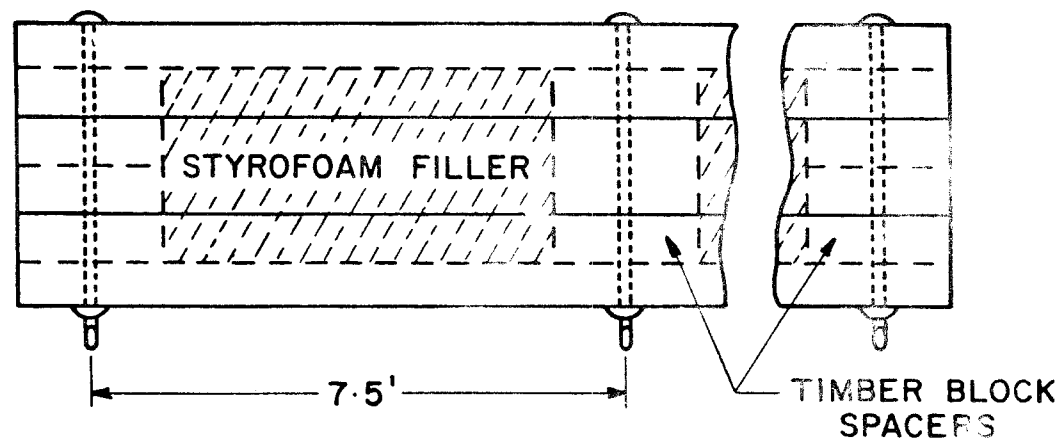

Fig. 36. Timber Float with Styrofoam Filler
(Kennedy¹⁰), Fig. 27)

Table 2. Performance of Model Booms in Waves

Summary of results presented in Water Transportation II¹⁰) showing comparable performance in % loss of logs after 20 minutes in model waves corresponding to field waves 46 inches high and with period of 4.4 seconds.

| Model Boom No. | Type | Approx. Overall Field Dimensions - in. | | | Specific Gravity Main Floating Member | % Wood Lost After 20 min. | Similar Model in Table 1. No. |
|----------------|-------|--|--------|---------|---------------------------------------|---------------------------|-------------------------------|
| | | Width* | Depth* | Height* | | | |
| d-3 | Net | 30 | 45 | 0 | 0.41 | 0 | - |
| d-7 | Net | 30 | 45 | 0 | 0.75 | 0 | 19 |
| c-4 | Core | 28 | 21 | 7-1/2 | Low | 1 | - |
| c-3 | Core | 28 | 21 | 7-1/2 | 0.75 | 3 | - |
| a-3 | Round | 56 | 28 | 0 | 0.75 | 5 | - |
| c-1 | Deep | 34 | 29 | 0 | 0.75 | 6 | 8 |
| d-2 | Fence | 40 | 33 | 0 | 0.75 | 7 | 12 |
| c-2 | Core | 28 | 21 | 7-1/2 | 0.75 | 13 | 9 |
| d-1 | Fence | 34 | 33 | 0 | 0.75 | 21 | 13 |
| a-2 | Round | 28 | 28 | 0 | 0.64 | 22 | - |
| d-6 | Net | 30 | 45 | 10 | 0.75 | 42 | - |
| a-1 | Round | 28 | 28 | 0 | 0.75 | 43 | 3 |
| d-5 | Net | 30 | 45 | 5 | 0.75 | 73 | - |
| b-2 | Flat | 34 | 12 | 0 | 0.63 | 83 | - |
| b-1 | Flat | 34 | 12 | 0 | 0.75 | 100 | 6 |
| d-4 | Net | 30 | 45 | 0 | 0.75 | 100 | - |

The core boom with extended stringers (Fig. 37 and c-3 in Table 2) is considerably better in waves than standard core boom (Fig. 22, number 9 and 10, and c-2 in Table 2). Since there is always the possibility of some wave action it would appear to be sound practice to use the longer stringers for all purposes.

Some companies build core booms with only the side stringers extended and thus manage to locate the chain hole a reasonable distance from the end. In the laboratory a number of sticks were built with chain holes diagonally through the core and a suitable distance from the end. Many different connections may be designed but there is a clear advantage in extending the stringers as close to the end of the stick as possible.

(iii) Glance booms

Interpretation of laboratory test data is a matter of judgement and experience. Fig. 38 represents the authors' suggested glance boom design geometry

* Overall Dimensions include all members such as stringers and net cables.
 Depth is vertical distance below top of main floating member.
 Height is vertical distance above top of main floating member.

PLAN VIEW

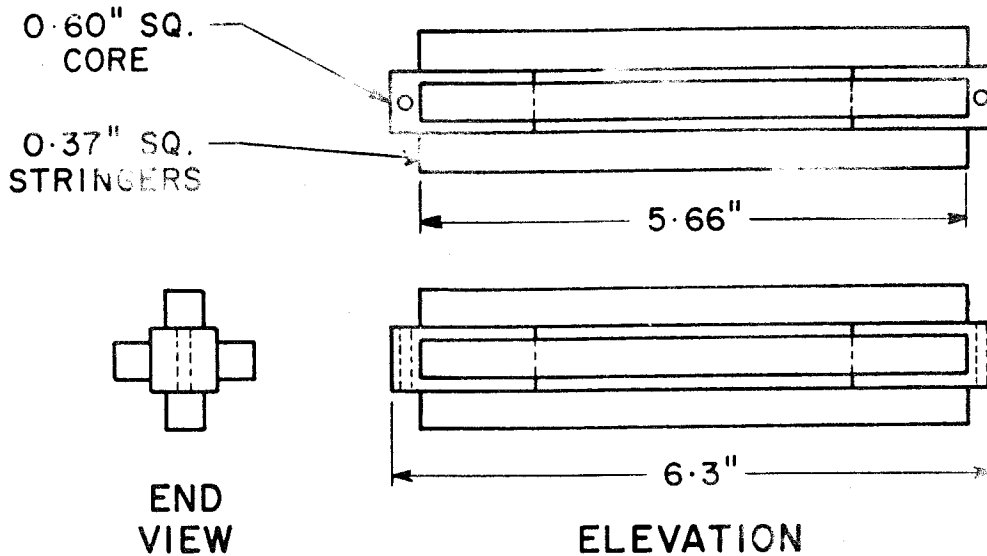

Fig. 37. Core Boom with Extended Stringers (Kennedy¹⁰, Fig. 21)

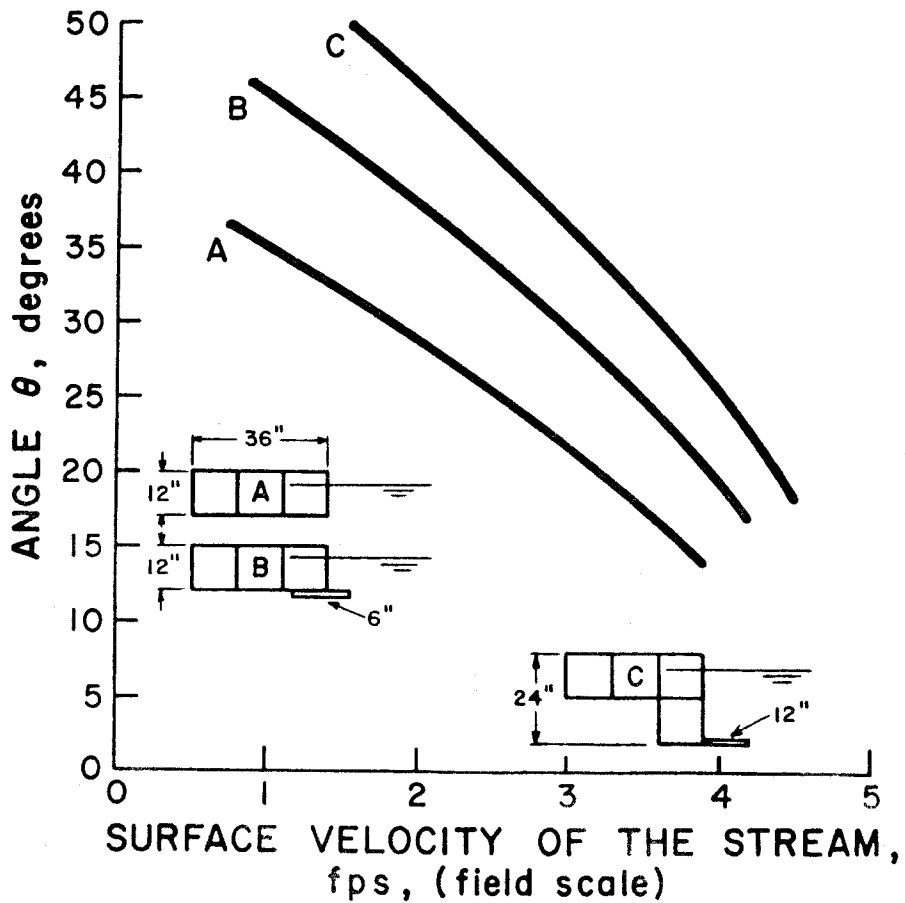

Fig. 38. Suggested Design Criteria for Glance Booms

for a range of velocities and angles of deflection. At the higher velocities (exceeding 2 fps) and at angles greater than 30 degrees, outriggers would be required, particularly on the deep boom.

Each line on this graph represents the likely maximum capacity of that type of boom. For given deflection angles and stream velocities, it will provide a useful indication of the type of boom which may be required. For example, a glance boom may be required to divert wood into a holding ground. The maximum angle between the boom and the direction of the current will be about 30 degrees and while the surface velocity is normally about 2 fps it may occasionally exceed 3 fps. Reference to Fig. 38 indicates that at a water velocity of 2 fps the B-type boom with lip should be adequate. When the velocity exceeds 3 fps the B-type boom may be approaching the limit of its capacity and some loss of low floating wood is to be expected.

If the high velocity periods are likely to be of short duration and if the escaping wood can be picked up in other operations downstream, then the B-type boom should suffice. If it is important to divert all wood into the holding ground, a deeper C-type boom is required. Outriggers should be used for stability, whichever boom is chosen.

Since the force, F , is generated usually by wind or current acting on the floating body, at the water surface, and the holding force, H , is generated by the anchor at the bottom, these two equal and opposing forces are not collinear (Fig. 39).

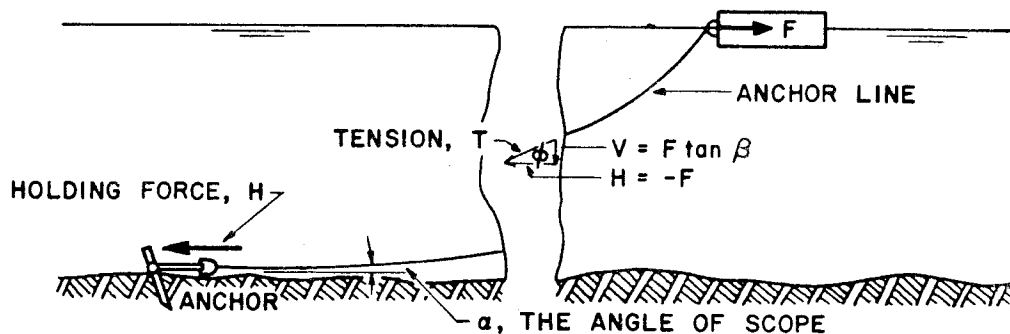

Fig. 39. Essentials of an Anchor System

The anchor is joined to the floating body by a line which, for best results, should lie very close to the horizontal at its connection to the anchor. That is, the angle of scope, which is designated alpha (α) in Fig. 39, should be close to zero if the anchor is to develop its maximum holding power.

T, the tension in the anchor line at any point, has two components, the vertical, $V = T \tan \beta$, and the horizontal, $H = -T$, as shown in Fig. 39. Beta (β) is the angle between the horizontal and the tangent to the curve of the anchor line at any point.

Since β , at the junction of the anchor line with the raft, is large, the vertical component of tension, V, is large and can be provided only by the weight of the anchor line or by the anchor itself. As will be shown later, in detail, it is advantageous to have a long and heavy anchor line or a long line with a heavy section next to the anchor in order to make the angle α , which is the limiting value of β , very small and thus ensure the efficient performance of the anchor.