

NASA/TM-2002-211631

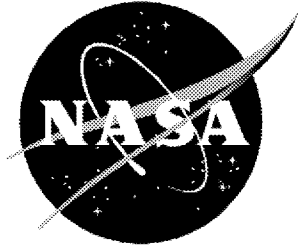

Flow and Noise Control: Review and Assessment of Future Directions

*Russell H. Thomas and Meelan M. Choudhari
Langley Research Center, Hampton, Virginia*

*Ronald D. Joslin
Pennsylvania State University, State College, Pennsylvania*

April 2002

The NASA STI Program Office . . . in Profile

Since its founding, NASA has been dedicated to the advancement of aeronautics and space science. The NASA Scientific and Technical Information (STI) Program Office plays a key part in helping NASA maintain this important role.

The NASA STI Program Office is operated by Langley Research Center, the lead center for NASA's scientific and technical information. The NASA STI Program Office provides access to the NASA STI Database, the largest collection of aeronautical and space science STI in the world. The Program Office is also NASA's institutional mechanism for disseminating the results of its research and development activities. These results are published by NASA in the NASA STI Report Series, which includes the following report types:

- **TECHNICAL PUBLICATION.** Reports of completed research or a major significant phase of research that present the results of NASA programs and include extensive data or theoretical analysis. Includes compilations of significant scientific and technical data and information deemed to be of continuing reference value. NASA counterpart of peer-reviewed formal professional papers, but having less stringent limitations on manuscript length and extent of graphic presentations.
- **TECHNICAL MEMORANDUM.** Scientific and technical findings that are preliminary or of specialized interest, e.g., quick release reports, working papers, and bibliographies that contain minimal annotation. Does not contain extensive analysis.
- **CONTRACTOR REPORT.** Scientific and technical findings by NASA-sponsored contractors and grantees.
- **CONFERENCE PUBLICATION.** Collected papers from scientific and technical conferences, symposia, seminars, or other meetings sponsored or co-sponsored by NASA.
- **SPECIAL PUBLICATION.** Scientific, technical, or historical information from NASA programs, projects, and missions, often concerned with subjects having substantial public interest.
- **TECHNICAL TRANSLATION.** English-language translations of foreign scientific and technical material pertinent to NASA's mission.

Specialized services that complement the STI Program Office's diverse offerings include creating custom thesauri, building customized databases, organizing and publishing research results . . . even providing videos.

For more information about the NASA STI Program Office, see the following:

- Access the NASA STI Program Home Page at <http://www.sti.nasa.gov>
- Email your question via the Internet to help@sti.nasa.gov
- Fax your question to the NASA STI Help Desk at (301) 621-0134
- Telephone the NASA STI Help Desk at (301) 621-0390
- Write to:
NASA STI Help Desk
NASA Center for AeroSpace Information
7121 Standard Drive
Hanover, MD 21076-1320

NASA/TM-2002-211631

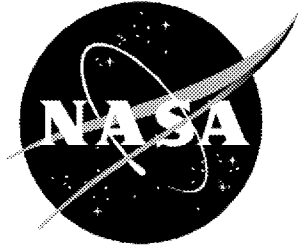

Flow and Noise Control: Review and Assessment of Future Directions

*Russell H. Thomas and Meelan M. Choudhari
Langley Research Center, Hampton, Virginia*

*Ronald D. Joslin
Pennsylvania State University, State College, Pennsylvania*

National Aeronautics and
Space Administration

Langley Research Center
Hampton, Virginia 23681-2199

April 2002

Acknowledgments

The initial draft of this document was prepared by a white paper team from NASA Langley Research Center. This team, which met from September 1999 to April 2000, included the following individuals: Robert Baals, Pieter Buning, Meelan Choudhari, Ronald Joslin, Harry Morgan, Daniel Palumbo, William Scallion, Michael Talley, and Russell Thomas. We thank all team members for the many hours of stimulating discussions as well as for their contributions to the original draft submitted to the Aerodynamics, Acoustics, and Aerothermodynamics Competency in May 2000. In particular, we thank Pieter Buning for contributing section 5, Harry Morgan for contributions to section 1, Daniel Palumbo for contributing section 3.2 and contributions to sections 7 and 8, and Michael Talley for contributions to section 6. A document of such wide scope has also benefited from interactions with many other colleagues from NASA, industry, and academia. While recognizing that the following list is not complete by any means, we gratefully acknowledge the generous help of Earl Booth, Dennis Bushnell, Chau-Lyan Chang, Edmane Envia, Don Garber, Thomas Gatski, Mehdi Khorrani, Kevin Kinzie, David Lockard, Tony Parrott, Jack Preisser, Kevin Shepherd, Bart Singer, Craig Streett, Mike Walsh, and Rick Wood. These colleagues contributed through editing, valuable discussions, or contributions in specific areas. We also thank Michael Marcolini for his contributions to both sections 6 and 7. A special thanks to Professor Geoffrey M. Lilley for his extensive review and numerous suggestions, especially pertaining to the section on jet noise and the airframe noise sections. Last, but not least, we thank our respective branch heads, Jack Preisser, James Thomas, and William Sellers, Jr., and the competency management (Ajay Kumar and Jerry Hefner) for their continued encouragement throughout this effort.

Available from:

NASA Center for AeroSpace Information (CASI)
7121 Standard Drive
Hanover, MD 21076-1320
(301) 621-0390

National Technical Information Service (NTIS)
5285 Port Royal Road
Springfield, VA 22161-2171
(703) 605-6000

Contents

Background.....	v
Symbols.....	vi
1. Summary.....	1
2. Introduction.....	1
3. Flow Control.....	5
3.1. Environment.....	5
3.2. Actuators/Effectors.....	7
3.2.1. Smart Materials.....	7
3.2.2. Vortex Generators.....	8
3.2.2.1. Microvortex Generators.....	9
3.2.2.2. Active Vortex Generators.....	9
3.2.3. Zero-Net-Mass Actuators.....	10
3.2.4. Piezoelectric Actuators.....	12
3.3. Drag Reduction.....	13
3.3.1. Natural Laminar Flow.....	14
3.3.2. Laminar Flow Control.....	15
3.3.3. Compliant Walls.....	16
3.3.4. Drag Reduction in Water.....	20
3.3.5. Wall Oscillations.....	22
3.3.6. Riblets.....	23
3.3.7. Large-Eddy Breakup Devices.....	25
3.4. Separation Control.....	26
3.5. Thrust Vectoring.....	29
3.6. Forebody Control.....	30
3.7. Wingtip Control.....	32
3.8. Flow Control Application Remarks.....	32
4. Noise Control.....	33
4.1. Exterior Noise.....	34
4.1.1. Turbomachinery Noise.....	34
4.1.1.1. Source Level Control.....	37
4.1.1.2. Control at Propagation Level.....	38
4.1.2. Jet Noise.....	40
4.1.3. Airframe Noise.....	44
4.1.4. Sonic Booms.....	48
4.2. Interior Noise.....	49
5. Synergy Between Flow and Noise Control.....	51
6. Concurrent Research Methods.....	54
6.1. Concurrent (Collaborative) Experimental/Computational Techniques.....	54
6.2. Further Facility Issues.....	56
6.3. Concurrent (Multidisciplinary) Computational Methods.....	57
6.3.1. Methods for Research.....	57
6.3.2. Methods for Design.....	58
6.4. Concurrent Methods Summary.....	59
7. Advanced Measurements.....	59
8. Breakthrough Technologies.....	61
9. Recommendations.....	63
10. Concluding Remarks.....	64
11. References.....	69

Background

The Flow and Noise Control White Paper Team was one of four teams assembled in November 1999 by the director of the Aerodynamics, Aerothermodynamics, and Acoustics Competency (AAAC), Dr. Ajay Kumar. The general mission of the white paper teams was to provide a vision for aerodynamics research and technology during the next decade that would serve as a basis for future planning of competency research and workforce. To that end, the present report provides a summary of the Flow and Noise Control White Paper Team's assessment of recent accomplishments in flow and noise control and some opportunities for future research in these areas. The document represents significant enhancements on the original document submitted to competency management in May 2000. The main motivators behind these enhancements have been to make the report more self-contained and to increase its utility to a general practitioner from any of the diverse array of technical fields involved (i.e., aerodynamics, aerothermodynamics, acoustics, control, materials, and structures).

Herein, the term "control" has been interpreted in a relatively broad sense, i.e., it represents any passive or active means of achieving a desired change in flow and/or noise metrics. Historically, passive control techniques have dominated both these worlds, with the control measure being implemented typically at a component level and, more often than not, on an *a posteriori* basis (i.e., as a fix). The past decade, however, has witnessed a changing of the guard in aeromechanics research, with an increased emphasis on harnessing the hidden potential of active flow control as implemented in a fully integrated, multidisciplinary framework. Consequently, technologies for developing radically new aerovehicles that would combine quantum leaps in cost, safety, and performance benefits with environmental friendliness have appeared on the horizon. Bringing their promise to reality would require coupling further advances in traditional areas of aeronautics with intelligent exploitation of nontraditional/interdisciplinary technologies, such as smart, distributed controls, novel actuators, and microelectromechanical systems (MEMs).

This paper provides a vision for potential gains both in terms of performance benefit for civil and military aircraft and a unique potential for noise reduction, via future advances and novel application of flow control technology. Similar benefits for other transportation systems, especially toward reduced cost for space access, are also indicated. It is hoped that this comprehensive vision will strongly dispel prevailing notions concerning the maturity of aerodynamics research. The team also believes AAAC is well positioned to exploit change in the aeronautics landscape, provided that a systematic effort is devoted to strengthening the in-house effort related to flow and noise control, with due recognition for the need of close interaction with other Langley competencies, academia, and commercial industries. This report outlines and prioritizes specific areas of research that will enable the breakthroughs necessary to bring the above vision to reality.

Symbols

A	amplitude
AAAC	Aerodynamics, Aerothermodynamics, and Acoustics Competency
ADP	advanced ducted propulsor
AEDC	Arnold Engineering Development Center
AST	Advanced Subsonic Transport
BART	Langley Basic Aerodynamic Research Tunnel
BEM	boundary element method
C_d	drag coefficient
C_{dpu}	uncorrected drag coefficient due to pressure
C_f	skin friction coefficient
C_{f_0}	baseline skin friction coefficient without microbubble injection
C_{lu}	uncorrected sectional lift
C_p	pressure coefficient
C_μ	mean + oscillatory suction/blowing coefficient
CAA	computation aeroacoustics
CADCAM	computer aided design, computer aided manufacture
CMT	continuous mold line technology
c	chord
$\frac{D}{D_{FP}}$	drag with riblets to drag for baseline flat plate
DR	drag reduction: one minus drag of polymer flow divided by drag without polymers
DFP	ducted fan propulsor
DGV	Doppler global velocimetry
DNL	day-night level

DNS	direct numerical simulation
DNW-LFF	German-Dutch (Large Low-Speed Facility)
DSPs	digital signal processors
d	jet diameter
d_c	core jet exit diameter
$d_{31}(pC/N)$	strain in the x-axis per volt when an electric field is parallel to the z-axis
EPNdB	effective perceived noise
$F+$	nondimensional frequency for oscillatory excitation
FAA	Federal Aviation Administration
FEM	finite element method
HARV	high angle of attack research vehicle
HLFC	hybrid laminar flow control
h	riblet height
$h+$	dimensionless height, $h(u_\tau/\mu)$
IR	infrared
L/D	lift-to-drag ratio
LEBU	large-eddy breakup
LES	large eddy simulation
LFC	laminar flow control
LITA	laser induced thermal acoustics
LTPT	Langley Low Turbulence Pressure Tunnel
LSAF	Low Speed Aeroacoustic Facility
M	Mach
MDOE	modern design of experiments
MEMS	microelectromechanical systems

MIT	Massachusetts Institute of Technology
NLF	natural laminar flow
P	pressure
PDV	point Doppler velocimetry
PIV	particle image velocimetry
PMI	projection moiré interferometry
PSP	pressure sensitive paint
P_T	total pressure
$P_{T\infty}$	free-stream total pressure
PVDF	polyvinylidene-fluoride
PVGs	pulsed vortex generators
PVGJ	pulsed vortex generator jet
PZT	piezoceramic
Q/Q_s	normalized injection flow rate
Q_s	flow rate in the viscous sublayer per unit span
QFF	Quiet Flow Facility
R	riblet radius
RANS	Reynolds Averaged Navier-Stokes
Rc	Reynolds number based on free-stream velocity and chord length
Re/m	Reynolds number per meter
SATS	Small Aircraft Transportation System
SPL	sound pressure level
SWCNT	single-wall carbon nanotubes
s	riblet spacing
s^+	dimensionless spacing, $s(u_T/\mu)$

T/W	thrust-to-weight
TAPS	Trans Alaskan Pipeline System
THUNDER	piezoceramic actuator
TVA	tuned vibration absorbers
U_w	streamwise velocity of compliant wall
U_∞	free-stream velocity
UFAT	Unsteady Flow Analysis Tool Kit
u_τ	wall velocity
V_w	normal velocity of compliant wall
VG	vortex generator
VGJ	vortex generator jet
VMD	video model deformation
wppm	weight parts per million (concentration)
X/δ	distance downstream of injector normalized by boundary layer thickness
x/D_c	axial distance nondimensionalized by core jet diameter
x,m	distance downstream of injector in meters
α	riblet angle
β	riblet angle
Δx	downstream distance
δ_f	deflection of flap in degrees
λ	riblet wavelength
μ	kinematic viscosity
τ	riblet angle
ϕ	diffuser angle

1. Summary

The nineties have witnessed a changing of the guard in aeromechanics research, with an increased emphasis on harnessing the potential of active flow control as implemented in a fully integrated, multidisciplinary framework. Consequently, technologies for developing radically new aerovehicles that would combine quantum leaps in cost, safety, and performance benefits with environmental friendliness have appeared on the horizon. Transitioning these technologies to application requires coupling further advances in traditional areas of aeronautics with intelligent exploitation of nontraditional/interdisciplinary technologies, such as smart, distributed controls, novel actuators, and microelectromechanical systems. This report provides both an assessment of the current state of the art in flow and noise control and a vision for the potential gains to be made, in terms of performance benefit for civil and military aircraft and a unique potential for noise reduction, via future advances and novel application of flow and noise technologies. Similar benefits for other transportation systems, especially toward reduced cost for space access, are also indicated wherever appropriate. It is hoped that this comprehensive vision will strongly dispel the prevailing notion that aerodynamics research has reached maturity.

The report outlines and prioritizes specific areas of research that will enable the breakthroughs necessary to bring this vision to reality. Recent developments in many topics within flow and noise control are reviewed, including sensors, actuators, active control methods, and applications. The flow control overview provides succinct summaries of various approaches for drag reduction (viz., laminar flow control and compliant coatings for skin friction reduction; active and passive vortex generators and riblets for separation control) and improved maneuvering (via thrust vectoring, forebody control, and passive porosity). Both exterior and interior noise problems associated with air transportation systems are examined, including dominant noise sources (viz., turbomachinery, jet, and airframe), physics of noise generation and propagation, and both established and proposed concepts for noise reduction. Synergy between flow and noise control is a focus and, more broadly, the need to pursue research in a more concurrent approach involving the classical disciplines of fluid mechanics, structural mechanics, material science, acoustics, and stability and control theory is pointed out. Also discussed are emerging technologies, such as nanotechnology, that may have a significant impact on the progress of flow and noise control. Finally, some recommendations and references to facility issues are made in order to provide a basis for NASA planning.

2. Introduction

Aerospace technology has accomplished an incredible array of flight achievements over the last century. From human-powered flight across the English Channel and from Crete to Greece to scramjet powered flight at hypersonic Mach numbers, and from micro vehicle flight to transports approaching one million pounds—these define just some of the boundaries of flight charted in this first century of flight.

Exploration of the boundaries has defined flight in its first century. That exploration will continue with ideas such as those above and probably many that sound even more futuristic at this time. For every flight environment tested and for every class of vehicle developed in the past there are probably at least an equal number of new applications that can be envisioned in the future. Nanoscale vehicles navigating the human circulatory system and planetary exploration vehicles flying the atmospheres of the gas giants are just two futuristic ideas of possible missions.

It is important to remember that often an aviation milestone appears impossible by much of the aerospace community and the public right up to the actual event itself. In 1982, for example,

Christopher Kraft, Director, Johnson Space Center, Houston, TX, gave a commencement address in which he recalled graduating as an aeronautical engineer in 1945 having been taught that it was impossible for an airplane to fly faster than the speed of sound because his professors had lectured the proof of this, hence the term “sound barrier” (Kraft 1982). And yet, within one year, in 1946, Chris Kraft was working on the X-1 project at NASA, which would do exactly that—fly faster than the speed of sound.

This juxtaposition continues even from within our own ranks. There is a perception that “it’s all been done,” and yet with a worthwhile mission resolutely undertaken, the seemingly impossible can and does get done. From a technological point of view, as far-reaching as the accomplishments of flight have been, they were done by solving, relatively speaking, the easy problems of aerospace technology. Many problems that have challenged researchers for decades remain ahead.

Pioneering research combined with new enabling technologies just recently emerging are very likely, given the astounding heritage of aviation, to chart whole new ventures and innovate flight within the current envelope. This innovation will allow expansion and viability of a great many concepts already explored or already in widespread use. Because they are concepts or systems already in use, it is a common misconception that they are already mature; however, it is more likely that this means they are ripe for innovation. This innovation will be required by demands on the aerospace industry over the next 20 plus years. These demands are all too familiar to the traveler and airport communities in the form of noise, congestion, environmental concerns, lengthy delays, and the like. To follow is a possible scenario of the projected demands on the air transport system out to 2020 and of some of the possible system solutions.

First, future needs in air transportation must be established. As the population grows and becomes increasingly mobile, the need to move more people from one location to another will continue to increase. Development of new airports and road systems will more than likely continue to lag the growth in population. This means more congestion and higher levels of traveler frustration. In order to avoid travel, more businesses will rely on major improvements in telecommunications. Fiber optic links between businesses and employee residences will reduce the need to travel. We have all seen the impact of the Internet on the way we communicate, and that technology is only about 15 years old. Our current mentality is that business should be conducted face to face and that teleconferencing is too impersonal. As satellite, microwave, and fiber optic systems expand and improve, these attitudes will change.

Even with growth in telecommunications, the Federal Aviation Administration (FAA) estimates that air traffic will grow another 43 percent by 2011 just for domestic large air carrier enplanements (Federal Aviation Administration 2001). Major aircraft manufacturers also forecast strong growth in traffic over the next 20 years. Airbus Industrie (1999) forecasts a 5-percent per annum increase in passenger traffic (revenue passenger-kilometers). This 5-percent annual growth will be primarily provided by the addition of new aircraft (66 percent), 20 percent will come from growth in the number of seats per aircraft, and only 14 percent will come from increased productivity. The result will be that the world’s airports will have to accommodate a 95-percent increase in the number of flights. Boeing (2000) projects similar strong growth with a 4.8-percent annual growth and a more than doubling of the world aircraft fleet from 13 670 to 31 755 by 2019. Boeing also specifically identifies the small regional jet market as growing in share from 7 percent of the fleet to 15 percent by 2019.

These projections reflect the overall trends that have been in place for many years as a result of deregulation and passenger demands. Inadequacies of the large hub system have resulted in an increasing demand for more point-to-point travel. The demand for safe and reliable service will only increase as congestion places more demands on safety and timeliness. Of course, demand for low fares will continue.

At some point fuel prices will stay at high levels and place increasing pressure on economical travel including aircraft performance. Capacity, safety, and economy, because of strong demand, represent areas where new aircraft technology, such as flow and noise control technologies, can create solutions that enable projected growth.

New technology solutions can also have an impact in new aircraft categories such as that of very large aircraft. Compared with passenger traffic both Boeing and Airbus project even stronger growth in freight traffic, 6.4 percent per year and 5.9 percent per year, respectively. This is related to one major difference in their projections: the need for very large aircraft capable of carrying about 550 passengers or more. Airbus' forecast is more aggressive with a projection of more than 1500 aircraft in this category, while Boeing forecasts the number of aircraft needed to be 1000.

Airbus has recently launched a new large transport in this extension of the market, the A380, with a capacity of 555 to as many as 800 passengers (Sparaco 2001). Airbus also forecasts the need for even larger aircraft with capacities of 800 to 1000 passengers to meet future demands on the most heavily traveled routes. Aircraft of this size (1 to 1.5 million pounds) will need to be, among other requirements, fuel efficient and able to meet stringent noise standards. High fuel efficiency can be obtained through the use of laminar flow control on the wings, tail, and fuselage of the aircraft. To date, NASA has conducted a great deal of research on laminar flow and has demonstrated that it is a viable concept (Joslin 1998a). However, none of that research was done at the Reynolds number (100 to 200 million) of these very large transports. Regarding large transports and other aircraft, a factor that greatly affects weight is performance of the high-lift systems. In general, the more complex the high-lift system the more it weighs. Systems with fewer elements using either passive or active separation control for the flap boundary layers will be needed for very large aircraft to meet field length requirements. Reducing the size of the wing lateral and longitudinal control surfaces can also reduce weight. Smart structure technology will play a vital role in the needed improvements in control surface effectiveness. These structures will also allow for continuous recontouring of the wing surface during cruise to further improve fuel efficiency. Meeting stringent noise standards is as important as attaining fuel efficiency. The impact of noise on the community will be of particular concern for these very large aircraft. Better methods of identifying noise sources and reducing noise by both active and passive methods, especially during takeoff and landing, will need research and development. However, very different from previous generations of aircraft, noise reduction measures will need incorporation from the beginning in designing all new air transport like these very large aircraft.

Another major need in transportation will be to move an increasing number of people short distances of less than 500 miles. Currently the common mode of short distance travel is by automobile over the national interstate road system. Travel between major commerce centers has been by short haul transport aircraft. There is little doubt that many current roadway and airport systems are beyond their design capacities. More roadways and airports are only short-term solutions. How do you move a large number of people short distances very efficiently? One possibility lies in high-speed trains traveling in excess of 250 mph. At these speeds, performance of the trains is greatly affected by aerodynamic shaping of the body and by suction forces generated between the underside of the train and its support rail. These trains probably will not travel on conventional ground-level rail systems, but will travel on elevated rails using magnetic levitation as a means of propulsion. Subsonic trains traveling up to $M = 0.3$ can develop some complex flows with compressibility effects. Crosswind instabilities and braking are examples of needs for further investigation.

Another possible solution to moving large numbers of people is to better employ low-altitude air space with civil tilt rotor vehicles and a new generation of general aviation aircraft. For this solution, the number of skyways, unlike highways, is almost unlimited. Currently, there are more than 15000 small

general aviation airports in this country that are underutilized. The key to developing a small aircraft transportation system is to provide technology that can be used to improve aircraft safety, performance, control, and navigational guidance. NASA has taken the initiative to make progress in this area with a small aircraft transportation system program (SATS). Eventually, these small aircraft will need to fly themselves in all weather conditions with only minimal input from the pilot, becoming more like a car. Because the pilot will be the average person with very little flight training, safety will be of the highest concern. These aircraft will need power plants that are highly reliable and fault tolerant, navigation systems that detect bad weather conditions ahead and automatically adjust the flight heading, and flight and flow control systems that help avoid wing stall, compensate for excessive free-air turbulence, and automatically take off and land the aircraft. These aircraft will eventually become almost autonomous. In addition to these aerodynamic requirements, the aircraft will need to be economical, of course, to achieve a level of widespread use that can have a net impact on the air transport system. This concept of pilotless flight may sound far-fetched now, but imagine the reaction of people at the beginning of the 20th century to the horseless carriage, and those of the mid-20th century to space flight—it does not have to be that far off in the future.

Noise impact will also eventually become an important aspect of a small aircraft transportation system. Large numbers of movements at low altitude will create a noise impact problem. This is true even for surface highways as the requirements for noise barriers continue to increase, and with the increasing recognition that transportation related noise has stressful effects on human life in metropolitan areas. A small aircraft transportation system will make it harder to avoid noise and will, therefore, require the application of aircraft noise research to new small aircraft vehicles from the beginning of their development.

The final topic under future aircraft needs involves requirements of the military, which, in most ways, are quite different from those of civilian aircraft. The military needs aircraft that are highly maneuverable, hard to detect, survivable, can operate at very high speeds, and can accurately deliver ordinance to a desired enemy target. To move troops, the military needs aircraft that can land and take off without airfields or with airfields that are badly damaged. The military of the future will be smaller, better trained, and more mobile than that of the past century. The military will need to strike targets with extreme accuracy and reduced risk to human life. To meet this objective, the military will rely more on remotely piloted aircraft to deliver destructive ordinance. Many flow control and acoustic concepts not practical for use on commercial aircraft may well be suited for use in military aerial weapons systems.

The flight of the owl provides an interesting motivation in designing military aircraft. The owl has a unique physiology enabling it to fly close to its prey in the middle of a forest and in total darkness. Even though the prey has good sound resolution in hearing above 2 kHz, the owl's features allow it to fly silently above 2 kHz and escape detection (Lilley, private communication, 2000). Rather than survivability, the requirement for quiet military aircraft may be more motivated by acceptable operations near population centers including those of military personnel. As military aircraft push to higher thrust levels and lower aircraft weights, the noise impact will increase on crew performance and community. This projected need without loss in vehicle performance will demand incredibly innovative solutions. It is therefore imperative that NASA develop strong cooperative research with the military that can benefit both civilian and military aircraft operations.

The applications of new and innovative aerodynamic flow control and noise control technology are critical to solutions for the needs mentioned above. The aerospace vehicles and transport system envisioned for the 2020 timeframe will have stringent goals placed on them. In some ways there are even more stringent goals or requirements that might be placed on the aerospace industry such as an emissionless vehicle, one with no pollution or noise impact. Without new solutions from technology, the new

transport system or aggressive goals for air vehicles that can benefit the public in such significant ways simply will not be realized. It is the intent of this report to outline many of the critical challenges for the physics of flow and noise control and some key technologies and directions that need to be pursued to make revolutionary advances in these disciplines.

3. Flow Control

This section summarizes progress in flow control technologies. While most of the early work in steady aerodynamic flow control focused on aerodynamic benefits, the later unsteady technology development areas are being pursued (generally) within a multidisciplinary, cooperative approach involving the classical disciplines of fluid mechanics combined with structural mechanics, material science, acoustics, and stability and control theory. More recently, innovative actuators, micro- and macrosensors, and advanced control strategies have been developed for flow control applications. Here, the recent discussion of flow control technology readiness for aerodynamics and hydrodynamics by Joslin, Kunz, and Stinebring (2000) expands on and focuses primarily on aerodynamic flow control. Other reviews of flow control include Gad-el-Hak et al. (1998) and Fiedler and Fernholz (1990).

3.1. Environment

Feasibility and readiness of using a flow control technology change with the choice of application. This becomes obviously clear because the governing flow physics and operating environment may change with each application. This section will briefly explore some of the environmental factors that impact technologies for air travel.

Most readers will probably be quite familiar with the operating conditions of a vehicle in air regarding altitude and Mach number because it is traditionally taught in most junior-level undergraduate curricula. At a glance this can quickly be understood by looking at figure 3.1. The figure shows a variation of temperature with altitude at atmospheric conditions ($M = 0.0$). Also, temperature variation is shown with Mach number for constant altitude flight because the vehicle under consideration for a flow control technology would be in motion. One can clearly see that Mach number plays a significant role in the environment (temperature) in which the flow control technology must operate.

Also, insects, dust, all forms of precipitation, and pollutants are environmental factors that must at some point be addressed to increase readiness of the technologies. Such issues are being catalogued through a number of resources. Figure 3.2 shows one resource that categorizes the regions of anticipated encounters with hail, bugs, sand particulate, and pollution with altitude. A significant amount of research is required to understand the impact or lack of impact of these environmental factors on a flow control technology. Simply understanding the regions of influence for an environmental issue requires extensive research. Studies of insects by Glick (1939) and Coleman (1961) suggest that the density of insects one would expect to encounter is a function of humidity, temperature (seasons), pressure, altitude, wind velocity, and insect size. Relationships have been studied and documented so we can estimate where and when insect contamination may be an issue for a technology. Very few flow control technologies have made it to a readiness level sufficient enough to begin studies of environmental impact.

In addition to environmental factors, a new technology must overcome economical, political, and social challenges, which are extremely difficult to predict. Although political and social perceptions/issues and economic forecasts are difficult to quantify, economic analysis can aid us in assessing challenges or barrier areas for a technology. For example, a flow control technology that provides only a *modest* drag reduction may find no air-related application in the near future. For the commercial aircraft

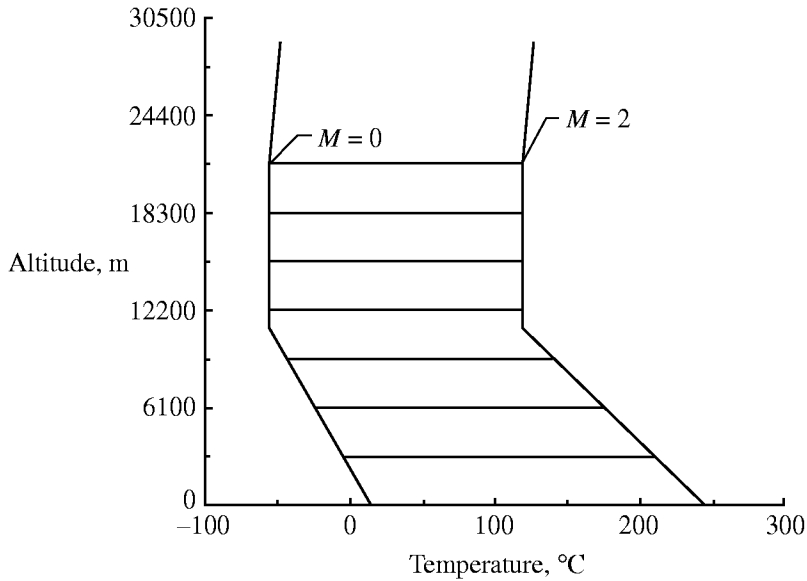

Figure 3.1. Temperature variation with altitude and Mach number (M).

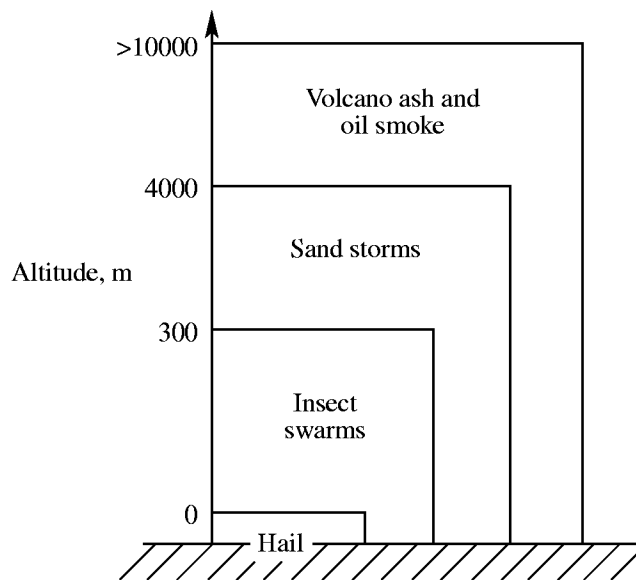

Figure 3.2. Environmental factors affecting flow control technology (Meifarth and Heinrich 1992).

industry, one can draw this conclusion by examining the cost of jet fuel relative to operating costs over a 24-year period (fig. 3.3). Granted it may be inappropriate to draw this conclusion from one data plot; yet this analysis reveals that fuel cost in the 1990s is a relatively small fraction of the overall operating cost for commercial aircraft. Hence the motivation to introduce new technologies that reduce fuel consumption may encounter some resistance from aircraft manufacturing companies. Of course, fuel is a commodity and subject to dramatic changes in price, as has become evident again in recent years. For example, in 2000 compared to 1999, airlines reported 40- to 50-percent increases in the price of jet fuel due to the rise in crude oil prices. Therefore, the demand for these technologies can also be expected to fluctuate. Since the development of new technology typically requires significant lead time, significant

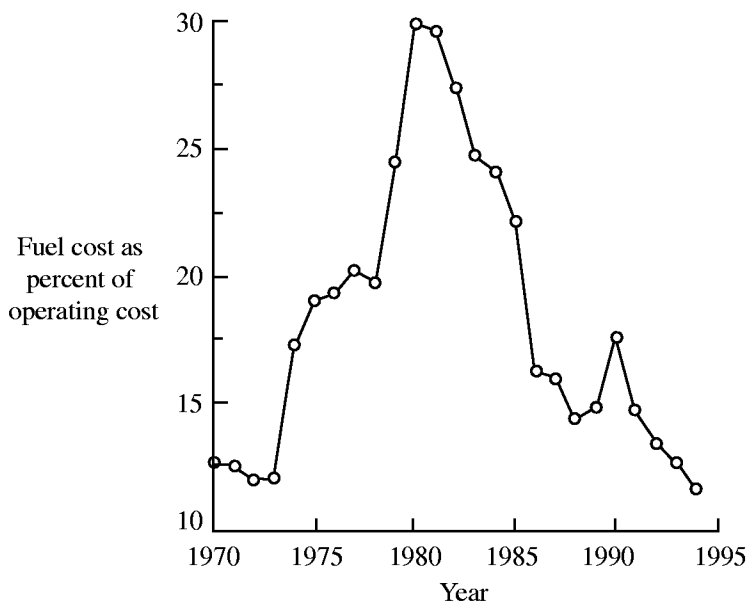

Figure 3.3. Cost of jet fuel to the airline industry (Anon. 1985, 1995).

forward planning is required. Also, drag reduction may enable new opportunities for propulsion system deployment because less thrust is required.

3.2. Actuators/Effectors

Actuator or effector technologies may be classified as passive in the sense that there is no energy input for their operation, whereas active systems require energy input to function. For a technology readiness assessment, we are interested in both passive and active actuators. In most cases, the passive actuators will be at a higher state of readiness than active systems.

3.2.1. Smart Materials

There is an abundance of results for piezoelectric smart materials used in air (Simpson et al. 1998). Typical testing of these devices occurs at room temperature or elevated temperatures. Figure 3.4 shows the measured piezoelectric displacement coefficient as a function of temperature for two wafers. The results indicate that the displacement performance of current piezoelectric devices increases with increased temperature. This variable actuator property would have to be accounted for if the application was applied to an environment with large temperature changes.

Based on current piezoelectric and shape memory alloy technologies, typically one may design the actuator to withstand large pressures; however, only small displacements are achievable (Simpson et al. 1998; Bryant et al. 1999; Cattafesta et al. 2000). Figure 3.5 shows the typical displacement performance of a piezoceramic actuator (THUNDER™) versus frequency. Clearly demonstrated here, the maximum displacement occurs at the resonant frequency conditions. Current piezoelectric technologies are insufficient to achieve full-scale control in most air-related applications because of small displacements achieved versus the application requirements.

Although the piezoelectric-type smart material will not in the near term be used for flow control on large-scale vehicle applications, using these devices in nontraditional flow control applications may be

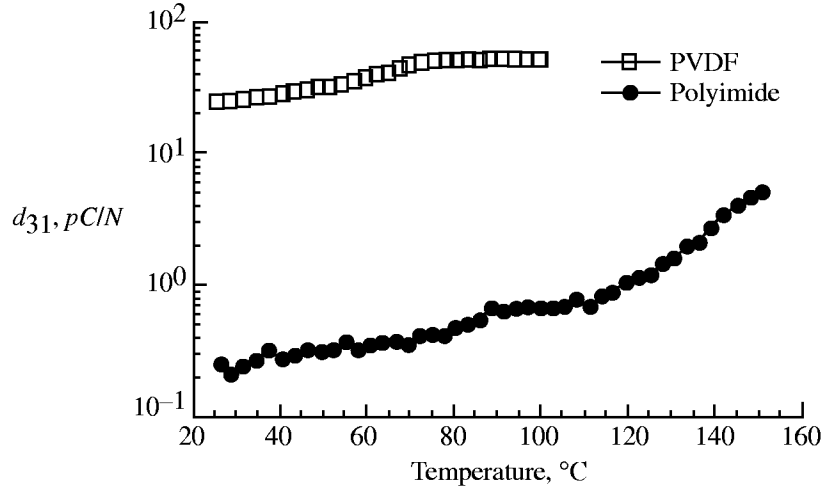

Figure 3.4. Piezoelectric displacement coefficient (strain/volt) as a function of temperature for polyimide and PVDF material (Simpson et al. 1998).

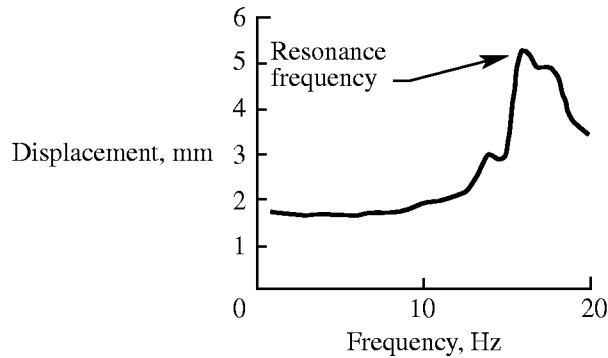

Figure 3.5. Displacement performance of THUNDER™ versus frequency (Simpson et al. 1998).

feasible both under water and in aerodynamic configurations. For example, piezoelectric drivers have been used in ink jet printers (Burr, Berger, and Tence 1996) to control ink ejection. As such, these smart material devices have been successfully incorporated into a nontraditional flow control application.

3.2.2. Vortex Generators

A vortex generator (VG) is a passive or active device used to induce a vortex. The need for this vortex is generally associated with preventing an otherwise separated flow condition that causes severe aerodynamic and hydrodynamic performance penalties. Large VGs (fig. 3.6) have been used on the aft portion of an aircraft to improve overall performance of the aircraft (see section 3.4 for additional discussion of separation control with VGs). Micro-VGs (less than one-quarter of the boundary layer thickness) have been used on the wings of production aircraft to prevent flow separation, primarily during takeoff/landing conditions. More recently, active VGs have been proposed and tested. The benefits of these concepts will be discussed in more detail in section 3.4.

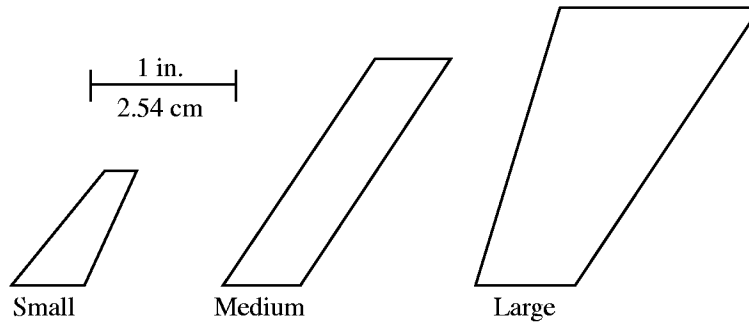

Figure 3.6. Vortex generators used for fuselage separation control (Wortman 1987).

3.2.2.1. Microvortex Generators

The micro-VG (Lin 1999) is a somewhat mature technology for passive flow control. However, significant effort is still required to (experimentally) determine where the VGs are positioned and what size/shape of VG is required for a given application. No correlation tools exist for the design/use of the VGs; however, a simple model of the actuator has been introduced for computational modeling of the induced effects of the VG on a given flow (Bender, Anderson, and Yagle 1999). A good experimental database is needed to better develop micro-VG models for CFD. Very detailed measurements of the flow downstream of these devices for turbulent flat plate boundary layers would be a good starting point, followed later by detailed measurements in a separated flow problem.

3.2.2.2. Active Vortex Generators

Active VGs may be applicable for separation control during aircraft takeoff and landing, and drag reduction during aircraft cruise conditions. These devices potentially have an advantage over conventional VGs because they can eliminate the parasitic drag that arises with VGs, and because the unsteady fluidic actuator can induce slip velocities (which may reduce drag) during cruise conditions. Depending on the operational use, VGs can interact with external flow even when they are unused (e.g., during cruise flight conditions).

One variety of the actuator consists of angled oscillatory pulses of fluid that are injected through orifices (vortex generator jet, or VGJ) (fig. 3.7). The angular injection causes streamwise corotating vortices to be produced in the flow. The vortices can cause an otherwise separated flow to become attached, thus leading to improvements in aerodynamic performance. McManus and Magill (1996) referred to this actuation technique as pulsed vortex generators (PVGs). This actuation technique works well at high angles of attack when the flow would otherwise be separated, but is essentially ineffective at low angles of attack when separation is not a problem. This discussion is expanded in section 3.4.

A second variety of active actuator (fig. 3.8) consists of a cavity with a flat plate asymmetrically aligned at the top face such that wide and narrow gaps are formed. Wind tunnel experiments found that a jet-like flow can emerge from the small gap (Jacobson and Reynolds 1998) or from the large gap (Koumoutsakos 1995). Computational results (Saddoughi 1995 and Saddoughi et al. 1998) showed that the actuator could produce either jet-like flow depending upon the scaling parameters of the actuator. Finally, still air (or bench-top) experiments (Lachowicz, Yao, and Wlezien 1998 and 1999) classified the potential flow fields that could be produced with the actuator. With the narrow gap width held fixed, varying the wide gap width, frequency, and motion of the plate led to a vertical jet-like flow, a vortex

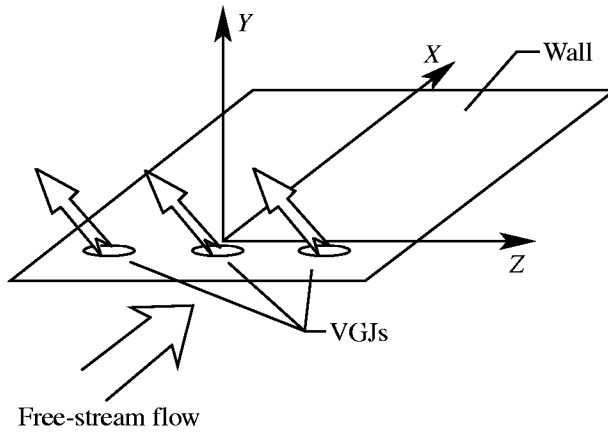

Figure 3.7. Sketch of pulsed vortex generator effector.

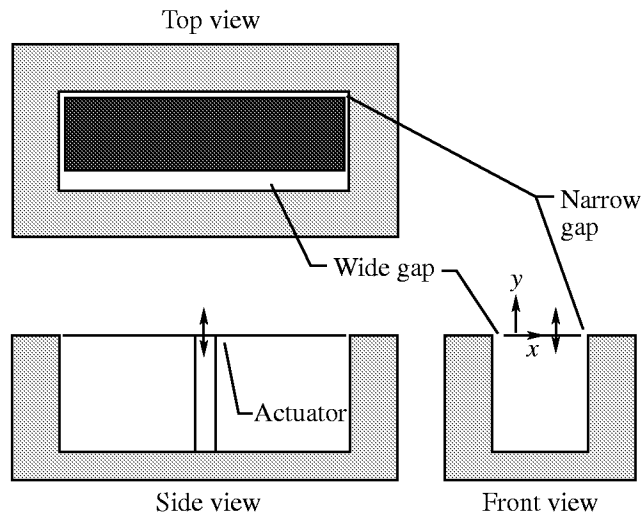

Figure 3.8. Sketch of on-demand vortex generator (Lachowicz, Yao, and Wlezien 1998).

flow, a wall jet flow, and an angled jet-like flow. This single concept for an active vortex generator can produce four different flow fields, potentially addressing multiple performance objectives for a configuration. Figure 3.9 shows an experimental snapshot of a vortex flow induced from this actuator.

3.2.3. Zero-Net-Mass Actuators

Some of the earliest research of zero-net-mass actuators (unsteady jets that produce zero time averaged mass flow) began in the 1950s with acoustical streaming around orifices by Ingard and Labate (1950). Their results showed four flow field regions that were a function of the driver frequency. The regions characterized the different observed flows emitted from the orifice. The results suggest a maximum velocity of 7 m/s was achievable with this early zero-net-mass actuator.

Recent studies by Wiltse and Glezer (1993), Smith and Glezer (1998), and Bryant et al. (1999) have demonstrated the use of microsized piezoelectric actuators for flow manipulation. Sketched in figure 3.10, the proposed piezoelectric actuator has piezoelectric diaphragms in a cavity. These

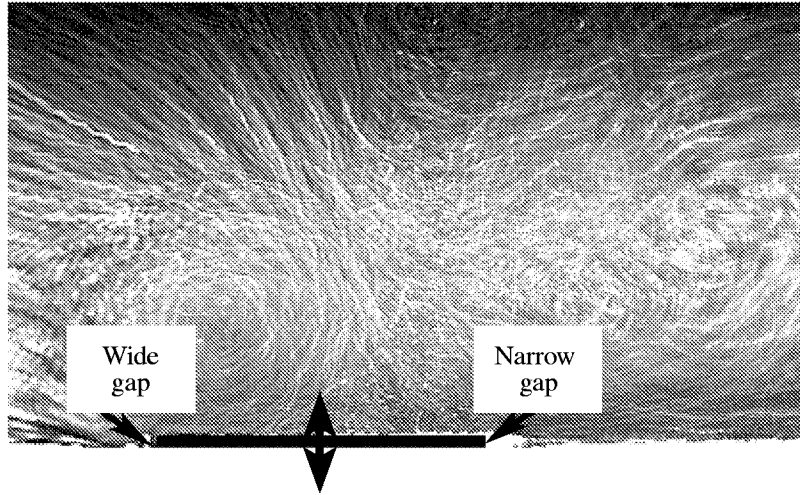

Figure 3.9. Actuator-induced vortex flow (Lachowicz, Yao, and Wlezien 1998).

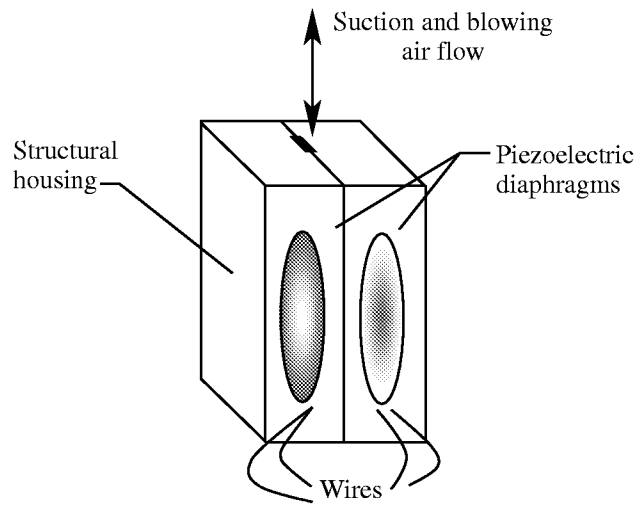

Figure 3.10. Sketch of synthetic jet actuator (Joslin, Horta, and Chen 1999).

diaphragms are driven with an oscillatory voltage that caused them to oscillate. The oscillatory motion forces air in and out of the opening (slot or hole) connecting the cavity with external air. The oscillatory motion yields a net mass flow of zero; however, jet-like flow fields can emerge with actuation. As a result, this kind of device has been referred to as a synthetic jet. Actuators of this type have been shown to generate velocities from a fraction of a meter per second to tens of meters per second and over frequencies ranging in the kilohertz. Joslin, Horta, and Chen (1999), Bryant et al. (1999), and Cattafesta et al. (2000) have made progress in modeling, designing, and building synthetic jet actuators. From the work of Bryant et al. (1999), figures 3.11 and 3.12 show the synthetic jet actuator and flow induced by that actuator, respectively.

One major obstacle that must be overcome with synthetic jet technology is associated with the significant noise source introduced by operating these devices at a resonant condition (which is the condition of maximum induced jet velocity). Even the frequency is below audible range for a full-scale application;

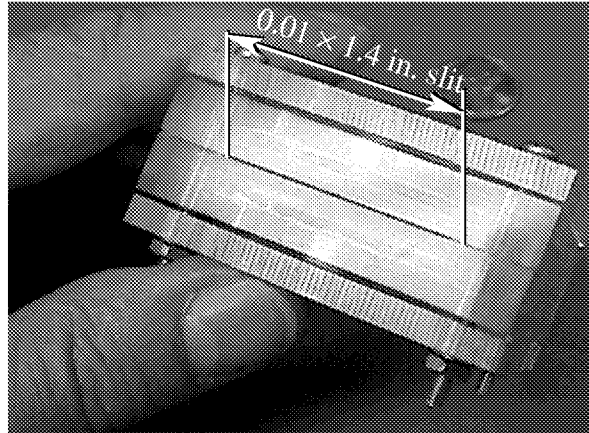

Figure 3.11. Prototype synthetic jet actuator (Joslin, Horta, and Chen 1999).

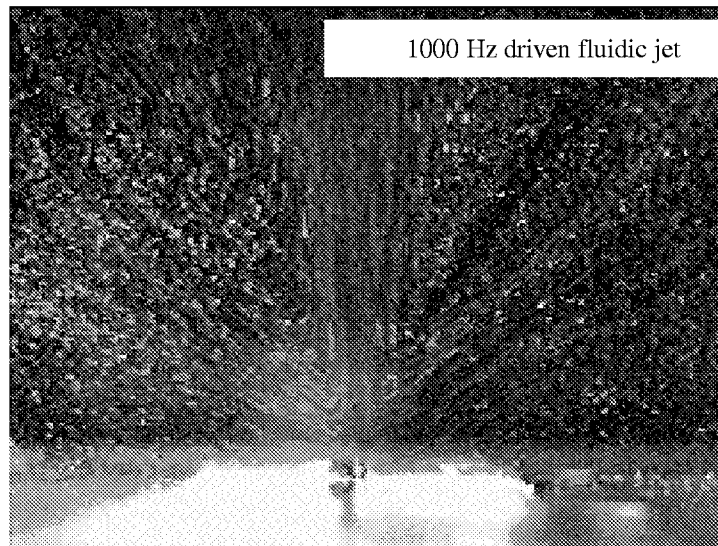

Figure 3.12. Laser-sheet flow visualization of flow field induced by synthetic jet actuator (Joslin, Horta, and Chen 1999).

the sound field can propagate for long distances and produce annoying vibration. One either limits the operation of these devices to nonresonant conditions or uses some form of noise control as potential means to overcome the obstacle. Finally, the mass flux from the current generation of devices is insufficient for most full-scale applications; however, potential stacking of the actuators may overcome this deficiency.

3.2.4. *Paraelectric Actuators*

The final actuator concept discussed in this paper is a paraelectric actuator, which involves the use of glow discharge plasma to induce a flow field in a boundary layer. Figure 3.13 shows three of a number of different configurations for the paraelectric actuator. Here the results for the asymmetric staggered configuration are presented. The concept works through an electric field gradient causing an acceleration of ions and the neutral gas or medium via particle collisions. Roth, Sherman, and Wilkinson (1998) showed

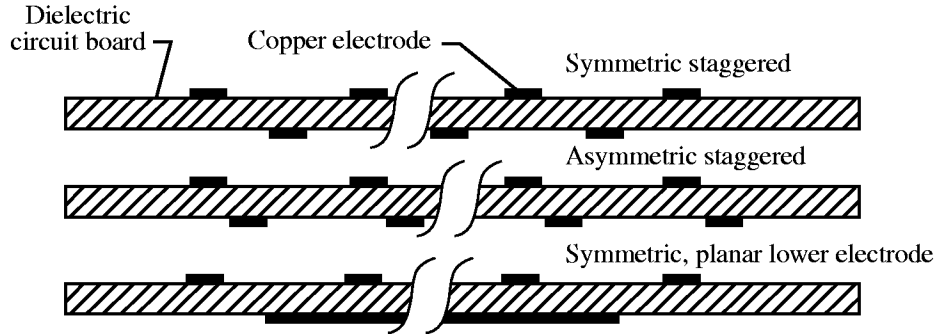

Figure 3.13. Sketch of paraelectric plasma actuator (Roth, Sherman, and Wilkinson 1998).

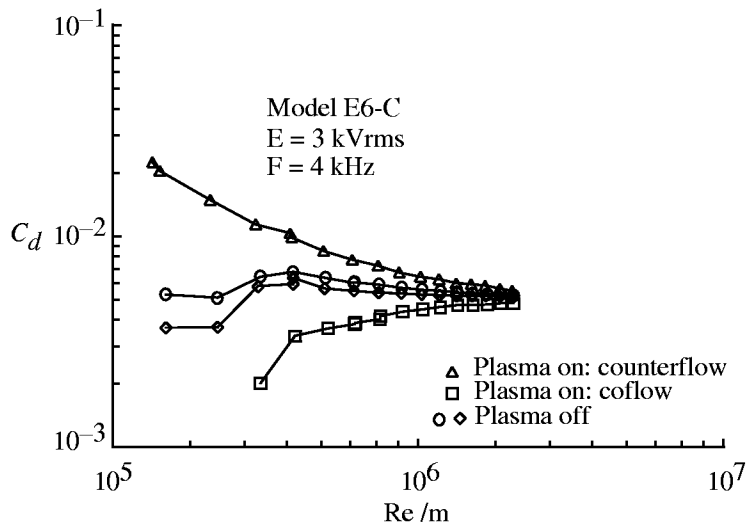

Figure 3.14. Drag results with variation of paraelectric actuator on flat plate flow (Roth, Sherman, and Wilkinson 1998).

that radio frequency plasma generated at atmospheric conditions can lead to induced wall-jet-like velocities. The actuator used in the bench-top experiments required 320 Watts per square meter of power. It is too early in the development of this actuator concept to make a proper assessment of usability for aerodynamic applications; however, initial results shown in figure 3.14 indicate that enhanced and decreased drag can result from the use of this actuator. For these results, 26 actuators were used in a turbulent flat plate boundary layer flow. With the bottom electrodes staggered downstream of the top electrodes, the actuator induces a flow in the streamwise direction (coflow). This leads to a net drag reduction. With the bottom electrodes upstream of the top actuators, the actuators induce a flow opposite of the streamwise flow (counterflow) and lead to an increase in drag.

3.3. Drag Reduction

The readiness of technologies that primarily focus on aerodynamic and hydrodynamic drag reduction are reviewed. These technologies include natural laminar flow, laminar flow control, particle (bubble/polymer) injection, wall oscillations, compliant walls, riblets, and large-eddy breakup (LEBU) devices.

3.3.1. Natural Laminar Flow

Overviews (Joslin 1998a, 1998b) of the topic and bibliographies (Bushnell and Tuttle 1979; Tuttle and Maddalon 1982, 1993) provide detailed definitions, reviews, and benefits of natural laminar flow and laminar flow control. Conferences dedicated to the subject include *Research in Natural Laminar Flow and Laminar-Flow Control*, March 16–19, 1987, NASA Langley Research Center with the Proceedings in NASA CP-2487 (eds. J. N. Hefner and F. E. Sabo), and more recently, the *First European Forum on Laminar Flow Technology*, March 16–18, 1992, Hamburg, Germany. A second European forum on laminar flow technology was held in 1996. Numerous flight tests document achievements in obtaining laminar flow in flight (Wagner et al. 1988; Holmes, Obara, and Yip 1984; Holmes and Obara 1992).

Essentially, the motivation for achieving laminar flow can be drawn out by examination of the drag balance, an example of which can be found in figure 3.15. Friction drag contributes to a large portion of the overall drag. Because laminar flow has considerably less friction drag than turbulent flow, maintaining laminar flow through natural means or active means can benefit the aircraft (or submarine, or automobile, etc.).

Natural laminar flow (NLF) employs a favorable pressure gradient to delay the transition process. Inherent in practical NLF wings is low sweep for small to moderate size aircraft (Holmes, Ahmed, and Nyenhuis 1985) with careful consideration of surface waviness and roughness tolerances. As the wing is swept, aerodynamic performance benefits are realized for high-speed aircraft; however, the now three-dimensional flow field becomes vulnerable to a boundary layer instability that is known as crossflow vortex instability. This causes the NLF design to become ineffective and the boundary layer flow to become turbulent very near the wing leading edge. For nacelles, the application of the NLF design has been shown to produce unacceptable low-speed performance, although some modern NLF nacelles have overcome earlier design deficiencies.

Although many difficulties with proposed NLF concepts have been overcome, insect and debris contamination on a surface (usually near the leading edge of the article) can cause portions of the NLF article to become turbulent. Numerous successful flight experiments (Joslin 1998a) have used paper covers, scrapers, deflectors, fluidic covers, thermal covers, liquid discharge, and flexible covers to prevent and/or

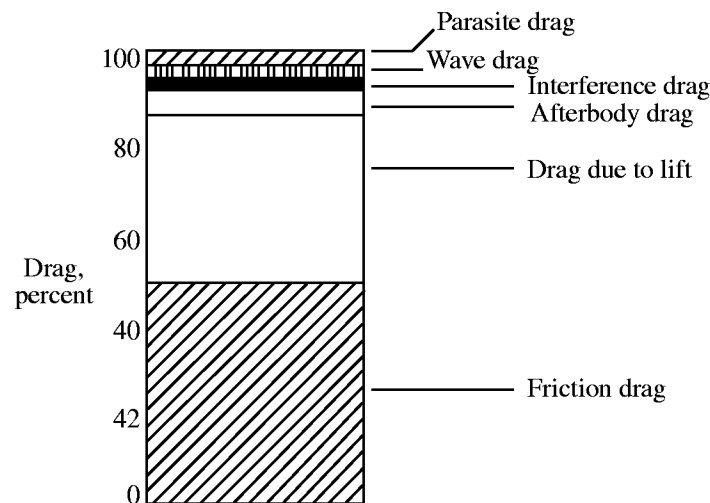

Figure 3.15. Subsonic transport drag breakdown (Thibert, Reneaux, and Schmitt 1990).

overcome issues relating to insect/debris-induced roughness. For some obvious reasons, these techniques, although successful for flight test vehicles, become impractical for production vehicles.

A new concept (Gottschalk 1996) suggests that natural laminar flow can be achieved by using a very sharp leading edge and thereafter shaping the wing contour to promote a favorable pressure gradient (promoting large regions of laminar flow). A recent flight experiment has demonstrated that natural laminar flow is achievable at supersonic speeds using this sharp leading edge concept (NASA Dryden News Release 00-13 2000). Bushnell (1990) discussed a number of potential drag reduction technologies beneficial for supersonic aircraft.

3.3.2. Laminar Flow Control

Laminar flow control (LFC) is an active boundary layer flow control technique employed to maintain the laminar flow at chord Reynolds numbers beyond that which is normally characterized as transitional or turbulent in the absence of control. Understanding this definition is an important first step toward understanding the goals of the technology. Often, a reader mistakenly assumes that LFC implies the relaminarization of a turbulent flow. These are two different flow physics phenomena, and although the same control system may be employed for both problems, the energy requirements for relaminarization could typically be an order of magnitude greater than that required for LFC. Finally, LFC is a capability that is designed to benefit a configuration during cruise by reducing the drag.

The majority of laminar flow control activities in air have been associated with the use of suction through porous, perforated, or slot surfaces. This air is then transported through flutes/ducts and pumped out of the aircraft at a nondetrimental location (i.e., the vented air does not cause a negative impact to the aerodynamic performance of the vehicle). Small amounts of suction delay the onset of transition by changing the curvature of the velocity profile in such a manner as to make the profiles more stable. Cooling (Dunn and Lin 1953; Parikh and Nagel 1990) has been shown to sufficiently stabilize the boundary layer to delay the transition of laminar to turbulent flow. Because viscosity increases with air temperature, the cooling works to cause the velocity gradient near the wall to increase and become more full and more stable. Reshotko (1979) looked at the feasibility of drag reduction using cooling for a large transport aircraft. The fuselage, pods (nacelles), and wings dominate the viscous drag contribution and therefore were considered for flow control. Cooling 75 percent of the wings, 20 percent of the fuselage, and all of the pods with a hydrogen cooling system (that also acted as the aircraft fuel) led to a projected 20- to 26-percent drag reduction. With the exception of some linear stability theory papers, very few published articles appear in the literature involving cooling-based laminar flow control applications; however, there are some novel and promising ideas involving cooling strategies for supersonic flight vehicles (company proprietary data). Cooling could avoid issues associated with insects/debris/ice particulate clogging the suction surface holes, whereas the potential issue of particulate-induced roughness must still be either addressed or ruled out as an issue. Finally, the cooling strategy would change the structural issue of a perforated surface.

A significant advancement made in the development of LFC technology was the concept of hybrid laminar flow control (HLFC). HLFC integrates the concepts of NLF with LFC to reduce active system requirements and reduce system complexity. These concepts, when integrated with the Krueger flap (for high-lift and ice and insect-contamination prevention), showed one potential practical application of HLFC on a wing (Powell 1987).

Recent experiments (Saric, Carillo, and Reibert 1998) have demonstrated a novel means of achieving extended laminar flow in swept-wing boundary layers dominated by stationary crossflow instability.

Unlike conventional LFC techniques (i.e., tailoring of pressure gradient and surface suction), which delay transition by enhancing the linear stability characteristics of the laminar boundary layer, the above technique uses receptivity control in conjunction with nonlinear mode competition to keep the flow from becoming turbulent. Specifically, leading edge roughness is used to excite relatively less dangerous disturbance modes into the flow; the disturbance modes can rob energy from the most unstable mode and, hence, delay the onset of laminar breakdown. The forced shorter wavelength disturbances involve comparatively smaller potential amplification. However, by virtue of higher initial amplitudes (as a result of forcing) and an earlier onset of amplification (typically associated with shorter wavelengths), these otherwise subdominant disturbances can achieve comparable amplitudes to the dominant mode and, therefore, suppress its growth via nonlinear mode competition. As the required roughness amplitudes are expected to be small (in microns), MEMs technology would offer a promising avenue to activate the control measure on a per demand basis. However, there is a need for additional studies to ascertain the potential of this technology for controlling transition in a generic three-dimensional flow, which may involve a significant presence of disturbance types other than stationary crossflow vortices.

Benefits of the variations of LFC are configuration dependent, change with time due to changes in fuel cost, system cost, and manufacturing technology efficiency improvements, and are closely linked to the amount of laminar flow and a host of other variables. Probably the single largest driver is the cost of fuel; however, LFC can also be used to introduce a new variable in the design trade offs that affects weight, noise, range, and other parameters (Antonatos 1966; Arcara, Bartlett, and McCullers 1991; Parikh and Nagel 1990; Powell, Agrawal, and Lacey 1989; Robert 1992). Due to uncertainty in the extent of laminar flow achievable and penalties of the control technology, benefits can range from reductions of 6 to 13 percent in total vehicle weight, 15 to 20 percent in block fuel, or a 15- to 25-percent increase in cruise distance. Quantitative estimates of noise reduction or emission/pollution reductions have not been published to date.

Thus far it has been evident in development that those obstacles to engaging LFC have been the real effects of atmospheric contamination (including insects), uncertainty in design tools, and the associated negatives of the suction systems that LFC are usually built around. These obstacles were observed despite the overwhelming success of the multiyear operation of the Jetstar flight experiment (Maddalon and Braslow 1990). The Jetstar's successful operational testing of LFC in air came at a period when the cost of fuel was sharply declining (fig. 3.3) and industrial support in such flow control technology was losing its foundation. In spite of this declining support, B757 (Collier 1993) subsonic and F16XL supersonic suction-LFC flight tests successfully achieved laminar flow in flight (Woan, Gingrich, and George 1991; Anderson and Bohn-Meyer 1992; Norris 1994; Anders and Fischer 1999; Marshall 2000). As shown in figure 3.16, most of the glove achieved laminar flow as a result of the suction control system. Anders and Fischer (1999) discussed many of the reasons that other portions of the glove remained turbulent.

Thus, suction laminar flow control technology is at a high readiness level; however, no current or planned production vehicle will make use of LFC.

3.3.3. Compliant Walls

Compliant coating research began with the postulation that dolphins achieved very high speeds through a natural drag reduction mechanism brought about through their compliant skins. As such, most research has used this argument as a basis for study. This attempt to link nature's wonders with engineering design has always existed in science and in the late 1990s research environment the term "biomimetic" arose as a means to classify this scientific reasoning.

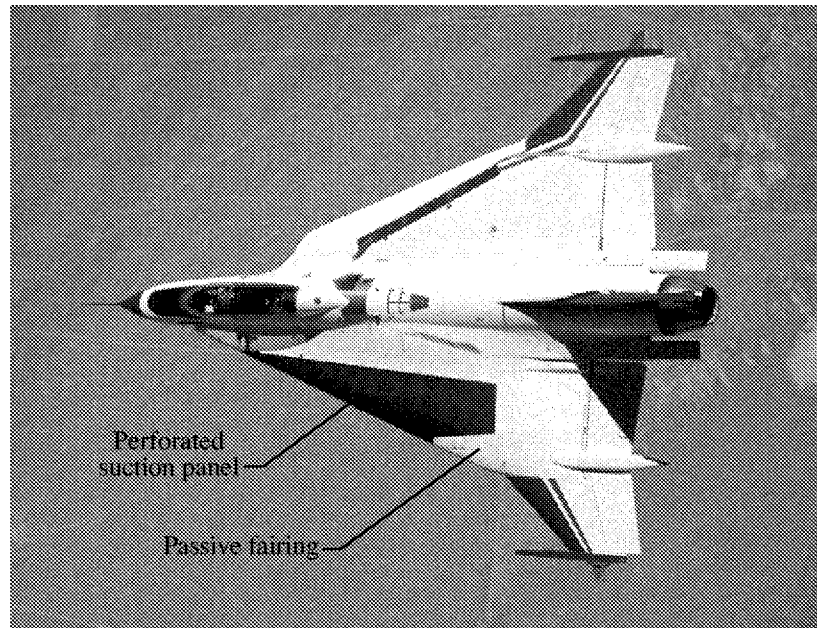

(a) Laminar flow control flight test using a F-16XL-2 aircraft (Anders and Fischer 1999).

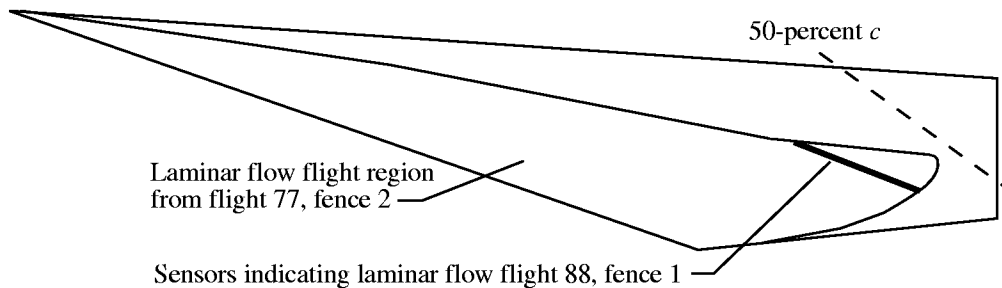

(b) Region of laminar flow achieved on F-16XL-2 supersonic wing glove during a laminar flow control flight test (Anders and Fischer 1999).

Figure 3.16. Laminar flow control technology readiness.

This link between the dolphin and compliant coatings arose from what is called “Gray’s Paradox.” Gray (1936) compared the resistance of a towed rigid body and the observed speeds of a dolphin to suggest that its muscles must generate energy at a rate seven times greater than any other mammal to attain the recorded speeds. Gray then proposed laminar flow/drag reduction as a means to explain the paradox.

Research involving flow over flexible walls exploded in the late 1950s when Kramer (1957, 1965) found drag reductions using rubber coatings over rigid bodies in water. Investigators in the 1960s focused on the task of experimentally duplicating and theoretically explaining Kramer’s results. The majority of these studies failed to produce any comparable results; yet, theoretical results laid the foundation for all future studies involving flexible walls. Interest turned toward use of compliant walls for turbulent drag reduction in the late 1970s and 1980s. NASA (Bushnell 1984) and the Office of Naval Research (Reischman 1984) sponsored investigations involving the use of compliant walls for the turbulent problem. Although most of the results from this era were either inconclusive or unsatisfactory, the

contributions, together with earlier results, have acted as stepping stones to the understanding of the physically complex fluid/wall interaction phenomena.

In the early 1980s, Carpenter and Garrad (1985, 1986) showed theoretically that Kramer-type isotropic viscoelastic surfaces (Kramer surface is a thin rubber membrane supported by rubber stubs and between the stubs is a viscous fluid) could lead to potential delays in transition by suppressing the amplification of Tollmien-Schlichting instabilities. They further indicated deficiencies in previous investigations that may have prevented achieving results comparable to Kramer's. Experiments performed by Willis (1986) and Gaster (1988) showed favorable results using compliant walls. Most of these studies focused on the two-dimensional instability problem, except Yeo (1986), who showed that a lower critical Reynolds number existed for the isotropic compliant wall for three-dimensional instability waves.

The compliant wall model (fig. 3.17) found in numerous theoretical studies was initially used by Grosskreutz (1975) in an experimental drag reduction study for a turbulent boundary layer flow. The Kramer surface can be modeled as an isotropic version of the Grosskreutz model. He suggested that the link between streamwise and normal surface displacements would cause a negative production of turbulence near the wall. Although his results for the turbulent flow were disappointing, the surface does react to the fluid fluctuations in transitional flow in such a way as to reduce production of instability growth.

Considering the compliant wall model used by Grosskreutz (1975), Carpenter and Morris (1989) and Joslin, Morris, and Carpenter (1991) have shown that three-dimensional Tollmien-Schlichting waves can have greater growth rates over compliant walls than two-dimensional waves. Although a conclusion consistent with the findings of Yeo (1986), these investigators showed that, even though three-dimensional waves may be dominant, transition delays are still obtainable through the use of compliant walls. Carpenter and Morris (1989) have shown by an energy analysis how the many competing energy-transfer mechanisms are influenced by the compliant wall presence. Of note is the reduced energy production by the Reynolds stress that may cause the reduced growth rates. Further, Joslin, Morris, and Carpenter (1991) predicted that transition delays of 4 to 10 times the rigid wall transition Reynolds number were achievable with this coating. Joslin and Morris (1992) showed in a secondary instability analysis with compliant coatings that the secondary modes could be suppressed because the primary modes were suppressed. Sample results in figure 3.18 show the amplification of primary and secondary instabilities for the compliant wall cases compared with the rigid wall case.

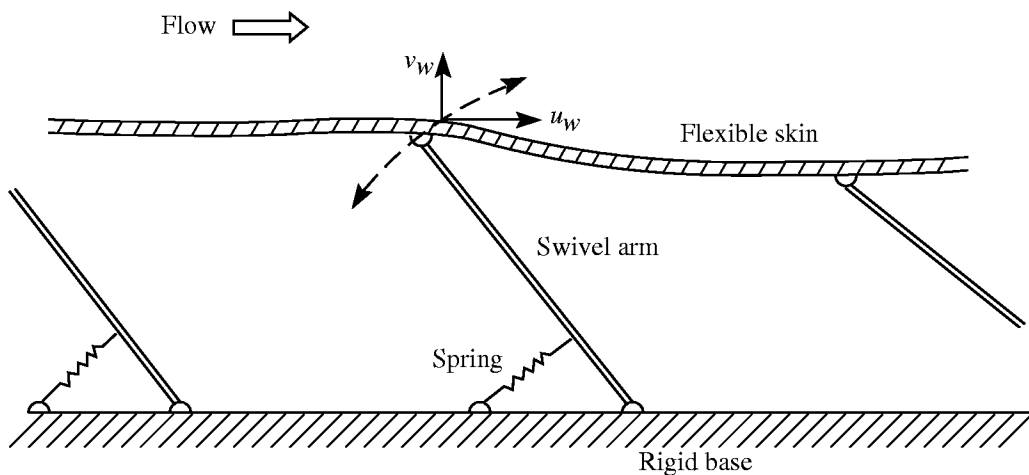

Figure 3.17. Sketch of Grosskreutz (1975) compliant coating.

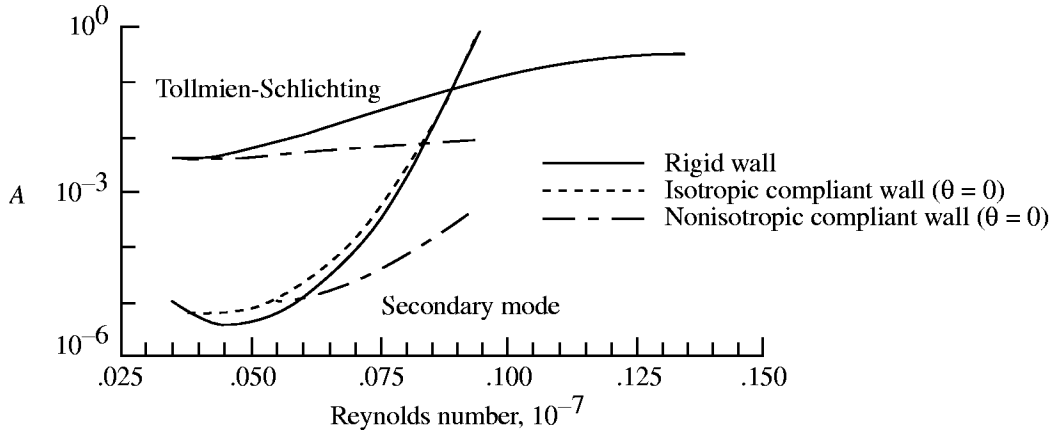

Figure 3.18. Amplitude growth as a function of Reynolds number for subharmonic mode of a two-dimensional primary wave rigid wall; isotropic (only wall normal motion is possible, $\theta = 0$, referring to fig. 3.17) compliant wall; and nonisotropic ($\theta = 60$, referring to fig. 3.17) compliant wall (Joslin and Morris 1992).

With a flexible wall present other modes of instability arise. With changes in the compliant wall properties, stable, or marginally stable, fluid and wall modes can become unstable and dominant as shown initially by Benjamin (1960, 1963, 1964), Landahl (1962), and Gyorgyfalvy (1967). Benjamin and Landahl separated the modes of instability over a flexible surface into three classes: A, B, and C. Examples of these are the Tollmien-Schlichting instability, which is a class A instability, and traveling-wave flutter, which is a class B instability. The class C instability, which includes static divergence, takes the form of a Kelvin-Helmholtz instability and may be represented as a function of the surface properties only. Unlike conventional class C instabilities, static divergence is an absolute instability (a surface mode that is unlike Tollmien-Schlichting waves, not convective); when present, static divergence destroys any transition delay potential that the surface may have otherwise had. Class A disturbances are generally destabilized by damping while class B disturbances are stabilized. Thus, attempts to stabilize class A instabilities have usually led to a destabilization of class B instabilities.

Carpenter's research (1993) suggests that Tollmien-Schlichting dominated transition can be postponed to very high Reynolds numbers using multiple compliant coating panels. As an example, Carpenter shows that the concept of maintaining laminar flow via compliant coatings appears most promising for applications such as hydrofoils and torpedoes, where the estimated skin friction drag reductions are 83 and 19 percent, respectively, compared with the submarine where no estimated benefit can be predicted. For submarine application the amount of drag reduction using compliant coatings for transition delay is very small because of high Reynolds numbers and mostly turbulent flow over the whole body. Obviously, the submarine would be a very exciting application for compliant coatings if turbulent drag reduction were feasible.

The fluid-solid interaction problem for drag reduction in turbulent flows is much more challenging and less understood compared to the above discussed laminar flow application. Whereas a few potential (albeit competing) modes are possible in laminar flows, the infinite dimensional problem exists for turbulent flows. Duncan (1986) has simplified the infinite dimensional system by assuming that a superposition of a convecting pressure pulse on a potential flow could represent a bursting event. The coating then responds to the pulse depending on its speed. As the flow becomes high speed, unstable waves develop on the coating. Such compliant coating disturbances have been documented in previous experiments (Gad-el-Hak 1987).

Carpenter (1993) suggested that the use of compliant coatings in air applications is impractical because the pressure fluctuations are insufficient to cause a coupling of the fluid-coating combination. As such, the coating would have to be very thin to be useful in air. The first evidence that such coatings may be viable in air was demonstrated in wind tunnel experiments by Lee, Fisher, and Schwarz (1995). The results suggest that amplification of Tollmien-Schlichting waves in air is possible with such coatings.

Finally, Fein (1998) performed a substantial review of the issues and claims of researchers associated with linking dolphin dynamics to compliant coatings and to drag reduction. Fein concludes that Gray's Paradox was built on incorrect data and there is no reason to believe friction drag reduction and the dolphin's motion are related. Fein does suggest, however, some form of wave or drag reduction may be possible for dolphin-like animals.

From surveying the published research on compliant coatings, substantial progress has been made in the transition suppression application and little progress has been made in the much more difficult turbulent drag reduction field. Perhaps no link exists between the dolphin's motion and compliant wall drag reduction; however, the substantial number of parameters introduced in this complex fluid-wall interaction problem suggests that with optimization techniques (Carpenter 1993) compliant coatings cannot be ruled out as a feasible approach for passive drag reduction for hydrodynamic applications. More experimental evidence must be available before such hope can be yielded for air applications. The reader can refer to more comprehensive reviews of compliant wall research given by Bushnell, Hefner, and Ash (1977), Riley, Gad-el-Hak (1988, 1996, 1998), and Carpenter (1990).

Although the focus of this review is on air-based flow control systems, compliant coatings were discussed in some detail because of the recent wind tunnel experiments by Lee, Fisher, and Schwarz (1995), which demonstrate for the first time that these coatings may lead to drag reduction in air applications.

3.3.4. Drag Reduction in Water

Suction systems become mostly impractical in seawater due to the rich variety of particulate the LFC system would have to encounter. As opposed to air, viscosity decreases with temperature in water, therefore heat applied to the surface would cause the boundary layer profile to become more stable.

Whereas active cooling can delay transition in air, underwater research and applications have focused on achieving laminar flow through active heating control. For example, Strazisar, Reshotko, and Prah (1977) forced periodic disturbances in a heated flat plate boundary layer. The results showed that Tollmien-Schlichting instabilities had decreased growth rates with the use of heating and that nonparallel effects were important near the critical Reynolds number. Additionally, research has focused on the use of particle injection as a means toward turbulent drag reduction.

Particle injection has been shown to either induce transition or suppress transition depending on unit Reynolds number and particle size. An experiment by Lauchle, Petrie, and Stinebring (1995) was conducted using an elliptically shaped axisymmetric model with a favorable pressure gradient. Heaters were used to control the location of transition. The level of heat required to suppress transition was a function of the free-stream speed (Reynolds number). Microspheres were used for particle injection. For particles injected into the free stream, results show that as the particle diameter is increased the transition location moves forward, with the turbulent spot formation beginning at the nose of the model. For particles injected through the nose, no impact on the transition location was observed in the experiments.

Associated with turbulent drag reduction, random-coiling macromolecules, polyelectrolytes, surfactants, and fibers have been tested primarily in pipes (Virk, Wagger, and Koury 1996). It is beyond the scope of the present investigation to get into detailed differentiation of these various additives; it is sufficient to note that the different properties of the additive impact the resulting turbulent flow and subsequent performance benefits.

Hoyer and Gyr (1996) summarize the concept of drag reduction in turbulent pipes by heterogeneous polymer injection. Homogeneous drag reduction involves polymer injection into the shear flow, only affecting the near wall region, and the core flow remains Newtonian. Heterogeneous drag reduction is achieved by injecting polymer concentrations into the core of the pipe flow. Even at low drag reduction levels, the core of the pipe flow is affected in this drag reduction approach. Hoyer and Gyr (1996) also note that drag reduction occurs at a certain onset value (critical shear stress) and is limited by an asymptotic value (Virk 1975; Virk, Mickley, and Smith 1970). A rather good historical perspective is given on the subject together with summarized trends in the velocity fluctuations, power spectra, and averaged time between bursts (which incidentally increased in drag reduced flows).

Numerous other experimental investigations have been conducted using polymer solutions providing a good database of different aspects of polymer-based drag reduction (e.g., polymer size, concentration, Reynolds number, etc.). Similar to the laminar flow control technology, a significant amount of successful studies have been achieved on realistic configurations. For example, a field test (Gasljevic and Matthys 1996) of surfactant-additive in the cooling system of a building has demonstrated (albeit sub-scale) a 30-percent reduction in pump power and drag reduction of 40 percent in elbows, 75 percent in straight sections, 60 percent in the chiller evaporator, and 35 percent in the air cooling coil. Unsatisfactory aspects of the investigation included lack of chemical stability as well as sediment and corrosion products contaminating the system. However, corrosive contaminants did not impact the system during the six months of operation and the authors believe the chemical stability issue is surmountable.

Finally, the most significant and mature technology of polymer-based drag reduction has occurred as a result of a large-scale test in the Trans Alaskan Pipeline System (TAPS). Motier, Chou, and Kommareddi (1996) noted that as a result of this test the petroleum industry has adopted this technique in pipeline oil transport in over 80 locations. The TAPS was designed to transport 2 million barrels of oil per day using 12 pump stations over 1287 km. TAPS began operations with 8 pump stations and a capacity of 1 million barrels per day. In 1979, the investigation of the use of polymer additives began to increase capacity. Two additional pump stations were built and the capability of using polymer additives was implemented. With a total of 10 pump stations and additives, capacity increased to 1.45 million barrels per day. By 1989, the polymer-additive technique had raised the pipeline's capacity to 2.1 million barrels per day (mechanical limit); hence, the polymer-based drag reduction technique brought sufficient benefit to the entire system, resulting in the 2 final pump stations never being constructed.

As shown by Petrie, Brungart, and Fontaine (1996), the use of polymers for external flows has demonstrated a 40- to 70-percent reduction in drag for flat plate boundary layer flows. As shown in figure 3.19, the amount of drag reduction (here defined as one minus drag with polymer divided by drag of baseline flow) varies with polymer concentration (wppm), tunnel velocity, and injection flow rate (Q/Q_s).

An alternative to polymer injection involves the use of electrolysis or injection to introduce air bubbles. Similar to polymer usage, employment of bubbles in the near wall region of a flow has a goal of drag reduction (through reduced skin friction). This two-phase flow in a boundary layer leads to less resistance (Latorre and Babenko 1998) and therefore a drag reduction. There has been a significant body of research in this area to make it technically feasible. A good discussion of aspects of bubble injection

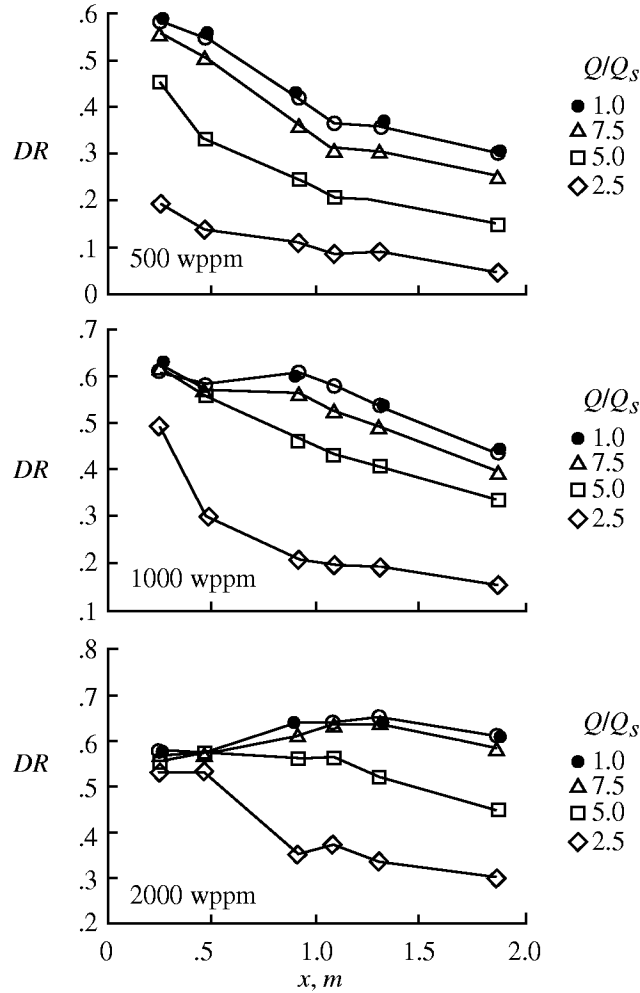

Figure 3.19. Drag reduction with polymer concentration and downstream distance (Petrie, Brungart, and Fontaine 1996).

was given by Meng and Uhlman (1998). Of note, the ratio of injection velocity to external flow velocity impacts the bubble size and formation, where the smaller the bubble the more likely it will remain near the wall. Research has included optimization (Bogdevich, Maltzev, and Maluga 1998) to minimize system requirements for a given level of drag reduction. Also, Madavan, Deutsch, and Merkle (1984) looked at the impact of different porous materials on drag reduction with microbubbles. Although they found that the material was irrelevant, the amount of porosity for different flow speeds did affect the resulting drag. Larger pore size and smaller surface area performed better for low-speed flows, whereas at higher speeds smaller pore sized materials led to better skin friction reductions. A sample result in figure 3.20 from Merkle and Deutsch (1989) shows the drag reduction benefits of using microbubble injection. The ratio of skin friction resulting from microbubble injection and the baseline skin friction for a flat plate yields the benefits in figure 3.20, depending on the operating conditions.

3.3.5. Wall Oscillations

A number of studies have been carried out to determine the impact of oscillations on turbulent drag. Choi and Clayton (1998) showed, through wind tunnel experiments, that spanwise oscillations of a wall

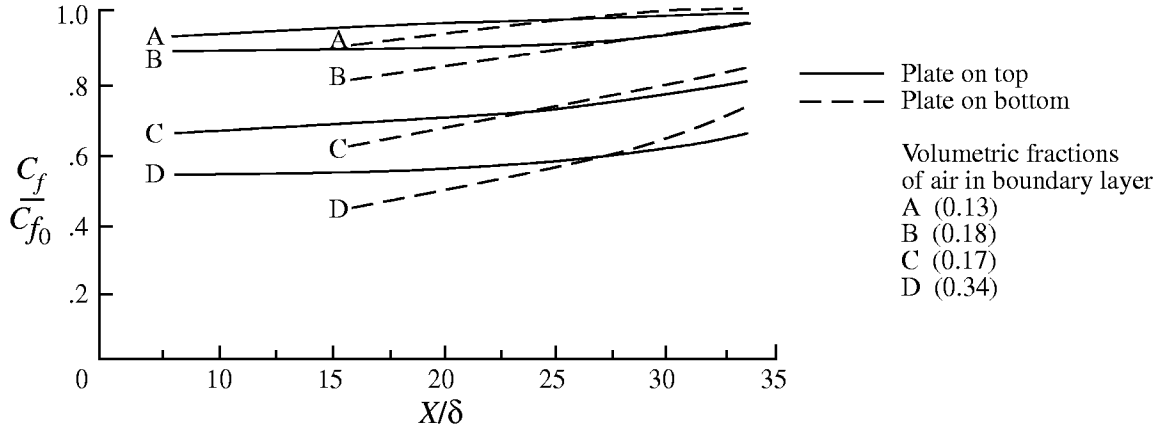

Figure 3.20. Skin friction reductions resulting from microbubble injection (Merkle and Deutsch 1989).

led to a 45-percent reduction in the skin friction of a turbulent boundary layer. The study was conducted at a Reynolds number of 1190 based on momentum thickness and with a moving wall frequency of 5 Hz. An analysis by Dhanak and Si (1998) suggested that reduction in skin friction and Reynolds stress on the oscillatory wall is associated with an annihilation of the low speed streaks.

With the goal of drag reduction, Choi, Moin, and Kim (1994) carried out direct numerical simulations with modified boundary conditions at the wall. To suppress sweep and ejection, time-dependent boundary conditions composed of blowing during sweep (fluid moving toward the wall) and suction during ejection (fluid moving away from the wall) were used. Approximately 20- to 30-percent reduction in skin friction was observed by controlling either the normal or spanwise velocity at the wall.

Finally, Guin, Kato, and Takahashi (1998) suggested a link between wall oscillation drag reduction and microbubble drag reduction. They proposed that a microbubble passing frequency scaled with inner variables led to a collapse of experimental data into a relationship between skin friction reduction versus this frequency. Further, they suggested the bubbles could act like a high frequency excitation mechanism in the near wall region, thus being comparable to wall oscillations.

An alternate means to achieve flow oscillations near a wall is by using unsteady suction/blowing. Tardu (1998) observed a drag reduction by using time-periodic blowing through a slot of a flat plate in a wind tunnel. Just downstream of the slot, the near wall region was reported to be relaminarized during the accelerated portion of the actuation.

Although wall oscillations tend to reduce skin friction levels, implementation issues similar to LFC may prevent the technology from reaching an application.

3.3.6. Riblets

Pioneering research using two different kinds of riblets occurred when Walsh (1980) reported an 8-percent drag reduction for a turbulent flat plate with a zero pressure gradient. He noted that inspiration came from the experimental study by Liu, Kline, and Johnston (1966), wherein rectangular fins aligned with the flow direction, spaced and sized according to inner wall variables, led to a 3- to 4-percent net drag reduction with those first riblets. Shown in figure 3.21 are typical riblet configurations tested by Walsh, and figure 3.22 shows drag results with the v-groove riblets versus the standard flat plate drag without riblets.

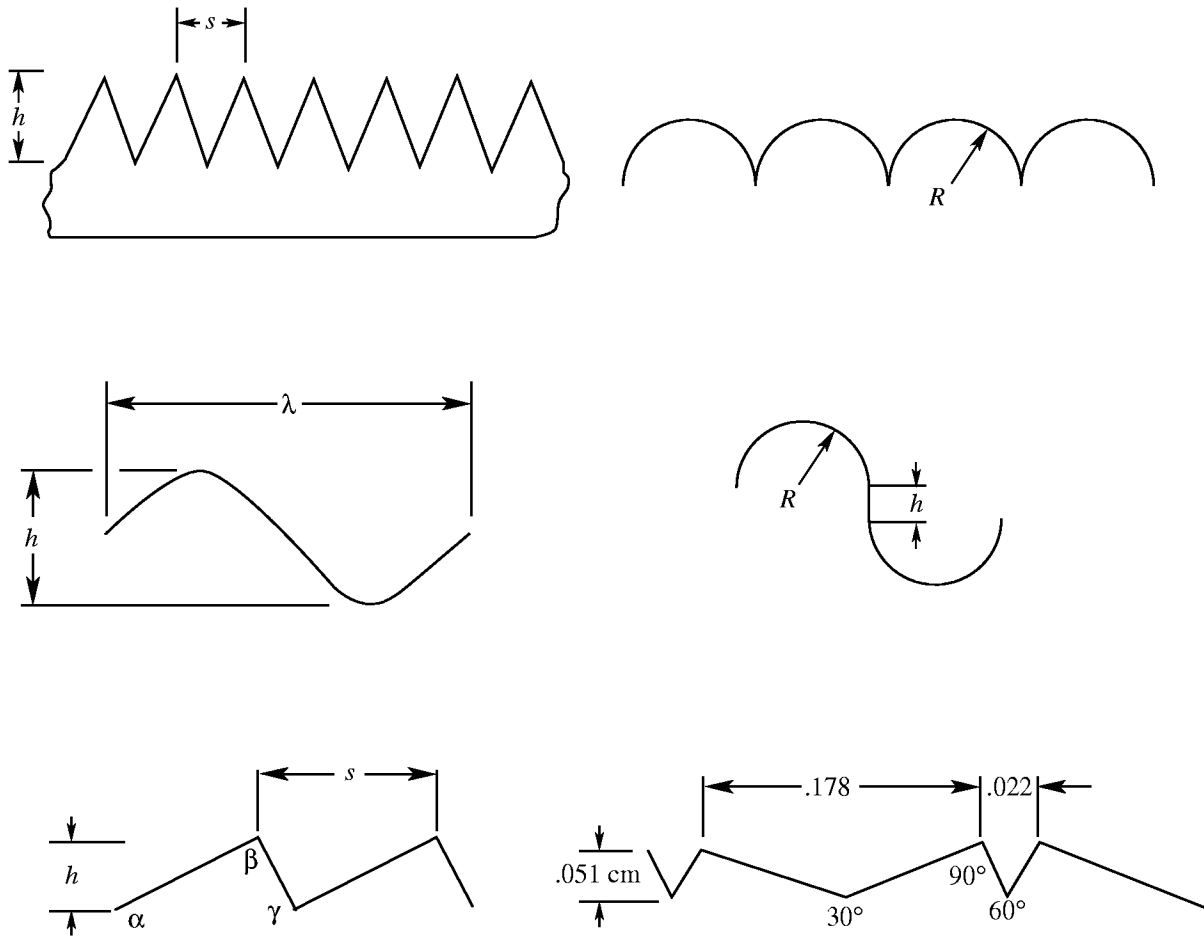

Figure 3.21. Riblet shapes tested by Walsh (1980).

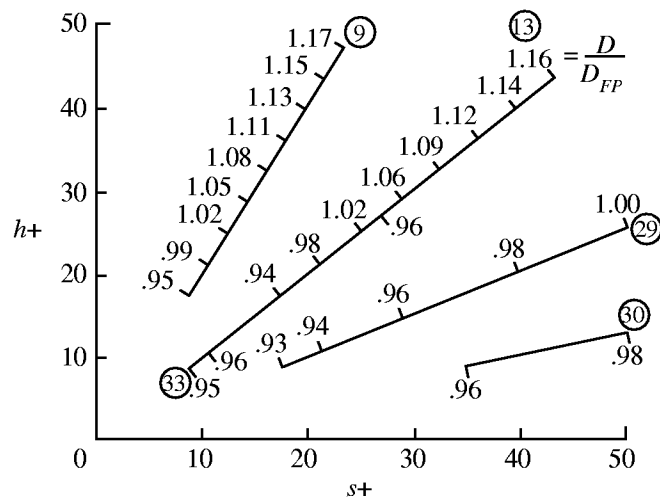

Figure 3.22. Ratio of drag using v-groove riblets to flat plate drag versus height ($h+$) to spacing ($s+$) variations (Walsh, 1980).

Walsh (1980, 1982) and Walsh and Lindemann (1984) performed numerous wind tunnel experiments on a variety of riblet shapes, sizes, and spacing to maximize drag reduction. They found a maximum repeatable drag reduction of 8 percent (± 1 percent) for a symmetric v-groove riblet and a sharp peak/concave valley riblet, both sized and spaced on the order of 10 to 16 wall units. However, consistent drag reductions were noted for riblets sized and spaced on the order of 25 to 30 wall units. Walsh (1980) noted that peak curvature led to decreased performance of the riblet technology. The riblets were effective up to 15° of yaw and lost effectiveness at yaw angles to the flow of 30° .

Research continued and later Bacher and Smith (1985) found a 25-percent drag reduction with v-groove riblets. The size and spacing of the riblets scaled with 15 wall units. The peaks of the riblets were flush with the test plate, whereas the previous investigations mounted the riblets on the test section wall. Gallagher and Thomas (1984) used v-groove riblets on a flat plate in a water tunnel and found no net drag reduction, although the near wall region of the flow difference compared with a smooth flat plate.

Walsh (1990) provides a good summary of riblets technology accomplishments. One notable accomplishment was the use of riblets on the America's Cup winner Stars and Stripes (Anders, Walsh, and Bushnell 1988; DeMeis 1988). Another accomplishment was achieved when Walsh et al. (1988) evaluated the effectiveness of riblets for drag reduction in flight using a business jet. Riblets were adhered to a near-zero pressure gradient region of the fuselage. Downstream of the riblet test section, a boundary layer rake was used to measure the velocity profile. Integrating the velocity profiles then provided a comparison of momentum; lower values indicated drag reduction. These flight measurements suggested that a 6-percent drag reduction was achievable in a real flight environment.

In application to commercial aircraft, Airbus Industrie is testing riblets on the A340-300 to study long-term durability of the technology (Mecham 1996). The upper surfaces of the wings, the upper fuselage, and both sides of the vertical stabilizer and tail plane have been fitted with the riblet film manufactured by Minnesota Mining and Manufacturing Corporation. The goal with this passive technology is to cut fuel burn by 1 percent through the drag reduction achieved with riblets. Therefore, riblets have reached a high technology readiness level, moving from laboratory testing to full configuration testing and environmental impact studies.

Very recently, Subaschandar, Kumar, and Sundaram (1999) reported up to a 10-percent drag reduction using riblets on a general aviation airfoil in a wind tunnel. A riblet film was applied from 12 to 96 percent of the airfoil chord. The amount of drag reduction increased with angle of attack up to 6° and was reduced up to 12° .

All of these previous studies with riblets involved two-dimensional riblets. More recently, Berchert, Bruse, and Hage (2000) examined three-dimensional riblet configurations that attempt to mimic shark skin patterns. Using between 1920 and 365000 tiny fin elements as riblets, they find drag reduction compared with the baseline case for a flat plate; however, more drag reduction is achieved with the two-dimensional riblets.

3.3.7. Large-Eddy Breakup Devices

Similar to riblets, research using LEBU devices is focused on reducing turbulent boundary layer drag through a passive device. However, unlike riblets that modify the very near wall behavior of the boundary layer, the LEBU concept involves placing thin plates or ribbons in a turbulent boundary layer to breakup large-scale structures in the flow. The alteration of these large-scale structures influences the



Figure 3.23. Streamwise view of an LEBU (Hefner, Weinstein, and Bushnell 1980).

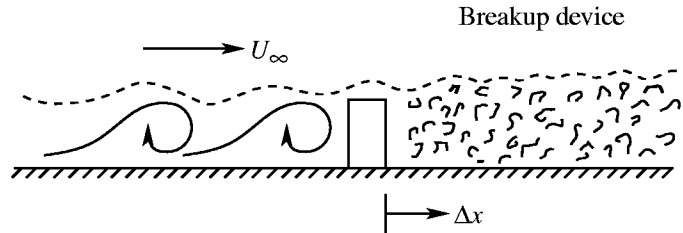

Figure 3.24. Schematic of how an LEBU device affects a turbulent boundary layer (Hefner, Weinstein, and Bushnell 1980).

turbulent production process and can lead to reduced skin friction tens to hundreds of boundary layer thicknesses downstream of the devices. Unlike riblets that size with inner variables of the flow, the LEBU device scales with boundary layer thickness.

Figure 3.23 shows a spanwise view of a typically tested LEBU, and figure 3.24 shows a schematic of how an LEBU breaks up the large-scale structure associated with a turbulent boundary layer.

Hefner, Weinstein, and Bushnell (1980) examined the LEBU concept on a turbulent flat plate boundary layer flow in a wind tunnel. The results using one and two element devices led to a 5- to 24-percent reduction in skin friction downstream of the devices. Net drag, however, was either negligibly increased or balanced the skin friction reduction.

Anders and Watson (1985) evaluated the LEBU on tapered plates and NACA 0009 and 4409 airfoil shapes. Unlike previous studies, the LEBU devices were very thick (more durable) and therefore stiff. Most notable was a 30-percent reduction in skin friction downstream of the LEBU and a 7-percent net drag reduction on the NACA 0009 airfoil configuration. No net drag reduction was found for the NACA 4409, mostly because of the separated flow caused by the LEBU.

Blackwelder and Chang (1986) studied the flow downstream of an LEBU in a fully developed turbulent boundary layer flow. The measurements indicate a 60-percent reduction in the streamwise velocity fluctuations directly downstream of the LEBU and the Taylor microscales were initially reduced 30 to 40 percent compared with the smooth flat plate case.

Finally, Bertelrud (1986) put LEBU devices on a wing for flight demonstration of the technology. A variety of 1 m long LEBU devices were placed on the swept wing for evaluation. The flight test data suggest that LEBU devices are feasible for real flying vehicles and that local skin friction reduction occurs even at transonic flight conditions with realistic pressure gradient effects.

3.4. Separation Control

Conventional high-lift devices are used during takeoff/landing operations to generate sufficient lift at low speed. However, these current systems incur a significant weight penalty to the aircraft and require added maintenance (and operating costs). Lin (1999) and Lin et al. (1994) have shown that using micro-VGs on the flap of a high lift system (fig. 3.25) can mitigate flow separation, leading to a

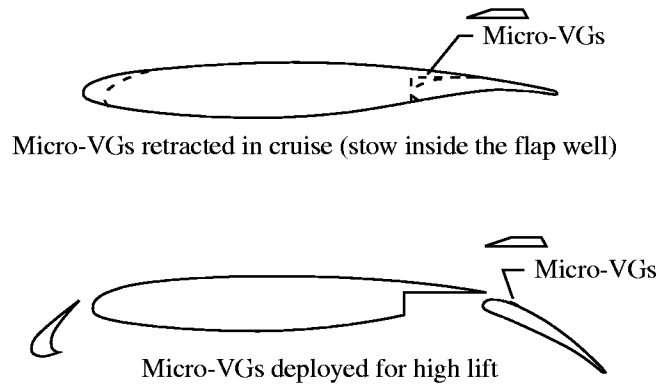

Figure 3.25. Multielement airfoil and micro-VG in cruise and takeoff/landing modes (Lin 1999).

10-percent increase in lift and a 50-percent reduction in drag. Together this leads to over a 100-percent increase in L/D . For the conventional high-lift system, the micro-VGs would be hidden during cruise conditions; hence, no drag penalty during cruise is generated with micro-VGs.

Not limited to separation control, vortex generators have been used in diffusers to reduce the distortion potentially evident in the complex geometries associated with diffusers (Taylor and Hoadley 1948a, 1948b; Anderson and Gibb 1996; Anderson et al. 1999). For a propulsion system, the more uniform the inflow to the engine face, the more efficient the propulsion system as a whole; however, as diffuser length is decreased, the flow typically becomes less uniform. Taylor and Hoadley (1948b) have shown that a 50-percent reduction in the length of the diffuser can be wrought by using vortex generators, causing as little as 5-percent loss of efficiency for a subsonic diffuser.

Vortex generators have been tested on a C-130 aircraft model to postpone separation (Calarese, Crisler, and Gustafson 1985). The afterbody of this configuration has a highly adverse pressure gradient and hence separation control would be beneficial to the aircraft. Results from tests of numerous placements of the vortex generators led to reduced drag compared with the baseline configuration. A similar study by Wortman (1987) with Boeing 747 and Lockheed C-5 aircraft models led to total drag reductions of 1 and 2 percent, respectively, for these configurations.

The application of vortex generators to low-Reynolds number large wind turbine blades was studied in experiments by Nickerson (1986). The results suggested no notable benefit of using vortex generators for this low Reynolds number flow; however, some questions about the experiments left conclusions unresolved.

Barrett and Farokhi (1993) tested a variety of active vortex generators on an NACA 4415 wing in a wind tunnel. The concept extends the research in vortex generators such that at low angles of attack the devices conform to the airfoils and are activated at high angles of attack when separation mitigation is desired.

Similar to active vortex generators, piezoelectric actuators (Seifert et al. 1998a) and leading-edge flaps (Hsiao, Wang, and Zohar 1993) have been used to control flow separation. Notable improvements in performance were measured, with the greatest effectiveness of the actuator occurring at a frequency near the natural shedding frequency of vortices in the shear layer.

Circulation control on a wing has been investigated to generate increased lift coefficients (Pugliese and Englar 1979; Novak, Cornelius, and Roads 1987; Englar and Applegate 1984). Engine bleed air is

blown through a slot on the upper wing surface just upstream of the rounded trailing edge. This blowing increased lift by several times compared to a conventional passive flap system. The application of circulation control technology to both lifting and control surfaces has the potential to provide improvements in performance and operational capabilities of both commercial and military aircraft. These significant potential benefits have been derived primarily from component studies on unswept airfoils.

An alternate to steady blowing for circulation control might entail the use of unsteady blowing in an attempt to reduce the amount of energy requirements to the control system. As such, separation control by unsteady tangential blowing over the flap of a wing/flap model was compared with steady blowing control by Oyster and Palmer (1972). The experiments suggested that a significant reduction in the amount of mass flow could be realized through unsteady blowing. As the pulsed frequency increased up to 60 Hz, lift also increased. Beyond 60 Hz, little or no gain in performance was measured.

A series of experiments by McManus and Magill (1996, 1997) and Magill and McManus (1998) on a variety of configurations demonstrated that the use of pulsed vortex generator jet (PVGJ) effectors near the leading edge of wings can mitigate the otherwise separated flow at high angle of attack. The approach has been demonstrated with frequencies ranging from approximately 10 to 250 Hz and is also a function of the directivity of the jets and jet/free-stream velocity ratio. Open loop results have been used to develop control laws (Magill and McManus 1998) for PVGJs, and closed loop control was demonstrated in the experiments.

Separation on a two-dimensional airfoil at angle of attack has been demonstrated in low and high Reynolds number wind tunnel experiments by the introduction of periodic momentum mass flux through a slot opening in the model (Seifert et al. 1993, 1996, 1998b, 1999a, 1999b). Although an oscillatory blowing valve was used to generate the periodic disturbance, any type of actuator having similar performance characteristics could have been used. The actuator-induced response was characterized by a dimensionless momentum coefficient and a frequency where the distance between the separation point (with no control) and the trailing edge is used as the characteristic length scale for nondimensionalization.

An oscillatory blowing valve was chosen because of the ease with which a steady disturbance, oscillatory disturbance, or superposition of steady and oscillatory disturbance could be generated. This technique was effective because it promoted mixing between the higher momentum fluid above the otherwise separated region and the lower momentum fluid at the surface. The enhanced mixing brings the higher momentum fluid close to the surface, making the boundary layer more resistant to separation. This active means of control has the advantage of eliminating or reducing separation without the performance degradation at off-design conditions associated with passive control. Also, the periodic control is two orders of magnitude more efficient than steady suction or blowing traditionally used for separation control (Seifert and Pack 1999b). Figure 3.26 shows results from Seifert and Pack (1999b) using oscillatory control on an NACA 0015 airfoil with a 20° deflected flap model. Clearly, the zero-net-mass oscillatory control yields both lift increase and drag decrease for this configuration.

Whereas the conventional takeoff/landing system is a multielement airfoil for transport aircraft, the zero-net-mass oscillatory excitation high Reynolds number experimental results suggest that an alternate simple flap/slat with flow control could replace the multielement system. As such, the first systems analysis was undertaken to estimate the benefits of replacing the conventional high-lift system with a flow control high-lift system (McLean et al. 1999). Assuming no performance gain with a flow control system, and by extrapolating the two-dimensional wind tunnel experimental results to scale, the study suggested that benefits such as part count reductions and weight reduction were possible with the flow control high-lift system.

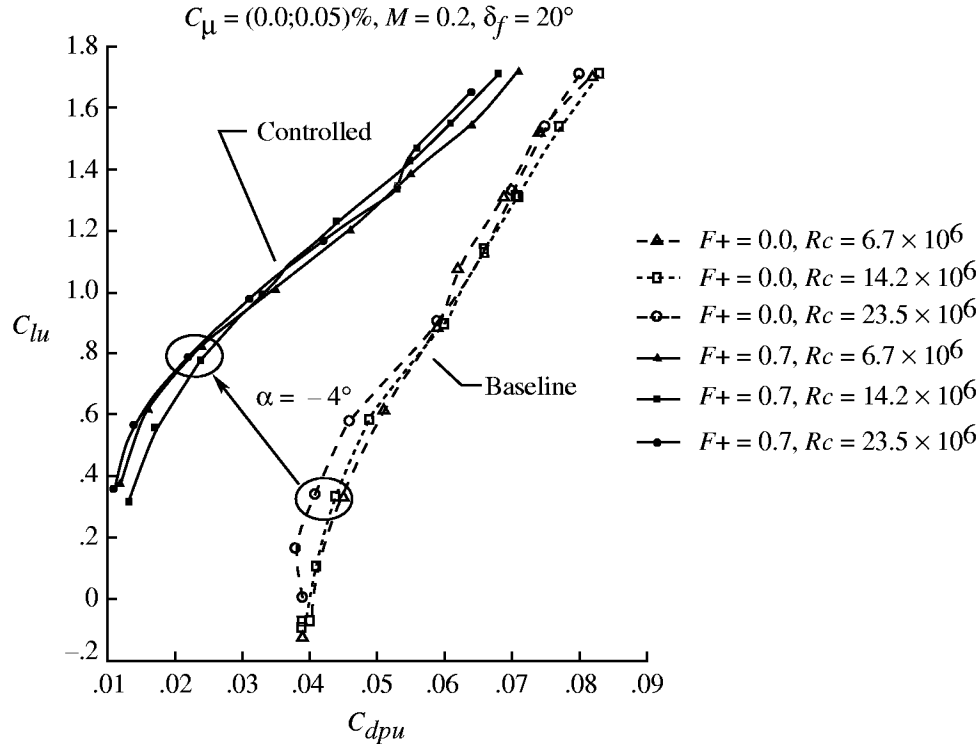

Figure 3.26. Lift-drag polars from separation control experiment (Seifert and Pack 1999b).

During maneuvering of a submersible vehicle, crossflow separation often leads to undesirable forces and moments. Wetzel and Simpson (1998) investigated the use of vortex generators (passive) and directed jets to control the separation process and mitigate the forces. Through oil flow visualization and force/moment measurements, the results indicated that yaw moment and normal forces could be reduced as much as 35 to 50 percent, and axial and pitching moments changed by 300 percent using vortex generators. The jets were ineffective in altering the forces/moments for this study.

3.5. Thrust Vectoring

Gilyard and Bolonkin (2000) used simplified equations of motion to estimate the ideal, or optimal, thrust vector angle for each flight phase of the aircraft. For takeoff, the objective would be to minimize the distance to aircraft rotation. The ideal thrust-vector angle was approximately 12° , noting that the thrust-to-weight (T/W) ratio dominates this determination with increased T/W giving increased thrust-vector angles (and benefits). For climb, the goal would be to obtain the maximum rate of climb with fixed thrust. For cruise, the objective would be to minimize thrust (i.e., fuel, noise, etc.). For both climb and cruise, an angle of 3° to 4° required the minimum thrust for these phases. For descent, the goal would be to achieve the best glide range for fixed thrust. Essentially, a near zero thrust angle was optimal. For climb, cruise, and descent an aircraft with lower lift-to-drag ratios requires higher thrust-vectoring angles for optimal conditions. For final approach, the objective would be to minimize approach speed. As the thrust-vector angle is increased the approach speed decreases; hence, very high thrust-vector angles (50° to 80°) are optimal for the final approach phase. High T/W benefits most from thrust-vector capability. For rollout, the objective would be to minimize distance. A thrust-vector angle of 25° to 28° proves optimal for this phase of flight and, obviously, reversed thrust is the beneficial direction of thrust. This type of information can be quite useful to assess which thrust-vectoring control technologies might be useful for the real application.

Conventional thrust vectoring technology involves using massive turning vanes to deflect flow in the desired direction. Such a means involves a heavy vane system. This concept, which is being considered for the Joint Strike Fighter, has been successfully demonstrated from ground based scale models to in-flight tests on an F-18 configuration (Bowers and Pahle 1996). The configuration is referred to as F-18 HARV (high angle of attack research vehicle) and was modified to accommodate a three-vane thrust vectoring control system. The results indicate that more vanes lead to better performance than a single vane. The desired jet exhaust deflection angles were achievable, however, with an expected loss in axial thrust. The in-flight test showed the pitch and yaw vectoring control of 0.9° and 0.6° , respectively, of plume deflection for every degree of vane deflection.

During the past few years, steady blowing techniques have been tested and show promise for diverting the primary engine jet flow some 15° from centerline. The blowing techniques have generally relied on engine bleed to achieve the mass flows required for the control approach.

Recently, oscillatory excitation has been demonstrated at low speeds ($M < 0.1$) to vector a jet flow some 8° from centerline (Seifert and Pack 1999a). For this experiment (shown in fig. 3.27), piezoelectric synthetic jets were used on the top quadrant of the collar as the driving effector; hence, no engine bleed would be required in practice. Rather, only power leads would be necessary to drive the effectors. Sample results from that study are shown in figure 3.28. The left image shows the oscillatory excitation in the jet-flow direction, the center image shows the baseline no control jet, and the right image shows oscillatory excitation into the jet (perpendicular). A thrust vectoring occurs as a result of the actuators. Seifert and Pack (1999b) note an 8° maximum deflection, which is in accord with the requirements defined by Gilyard and Bolonkin (2000) for most operational conditions of an airplane.

The benefits of reduced weight and maneuverability are attractive to both military and commercial applications. Research should proceed with the development of novel effectors capable of operation at high jet speeds, which are typical of the real application.

3.6. Forebody Control

For bodies of revolution at high angle of attack, side forces appear in the nose, or forebody region, with sufficient intensity that control surfaces may be rendered inadequate to control the body. With fighter-type aircraft at high angle of attack, the conventional control surfaces may become ineffective with the onset of forebody yawing moment forces. An active control system that can serve to eliminate the undesirable forces and impose desirable forces (control) is preferable.

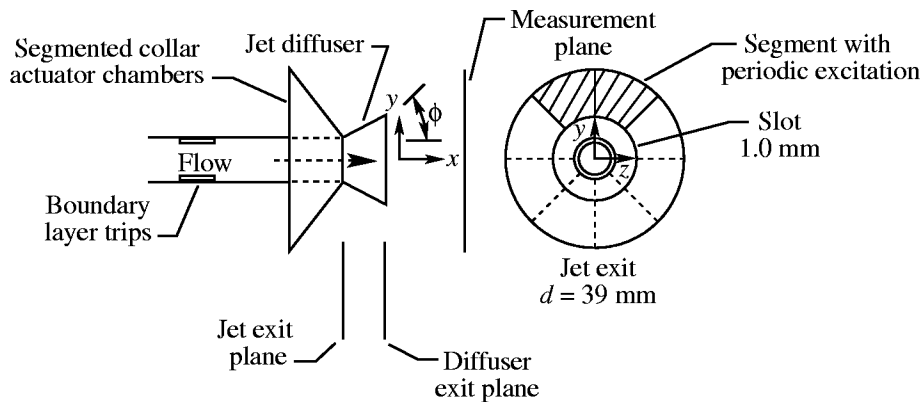

Figure 3.27. Low-speed thrust vectoring experiment (Seifert and Pack 1999b).

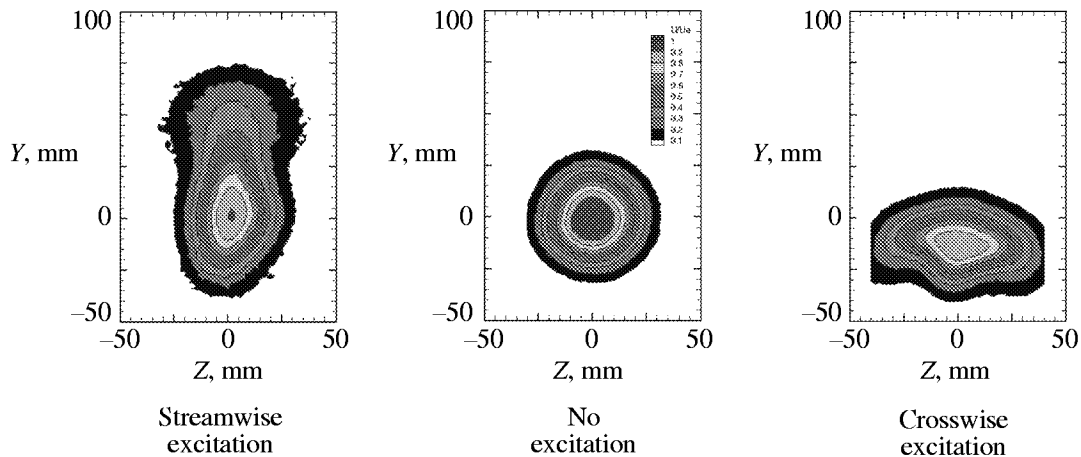

Figure 3.28. Hot-wire measures plane 2.5 diameters downstream of jet (Seifert and Pack 1999b).

Forebody control is a complicated technical challenge. Any potential asymmetries in the nose geometry can be sufficient to cause asymmetric vortices. Nose slenderness becomes an issue as well. For example, Ericsson and Beyers (1999) discussed the comparison of using forebody control on a fighter versus a high-speed transport type aircraft (slender nose). The analysis suggested that the relation between the blowing rate and moment could be characterized as linear at low angle of attack and nonlinear at modest angles of attack. Furthermore, very low rates of blowing can cause asymmetries in the induced flow field. Hence, to avoid this undesired phenomenon, the tolerances on manufacturing the surface and orifice may be extreme; this tight tolerance specification may make the technology unattractive because of large manufacturing costs.

Malcolm (1991) discussed the use of movable nose strakes (Murri and Rao 1987; Malcolm and Skow 1986), blowing surface jets (Peake, Owens, and Johnson 1980; Moore et al. 1980), blowing and suction surface slots (Ng and Malcolm 1991(a); Rourke et al. 1996), suction through surface holes (Ross, Jefferies, and Edwards 1990), and miniaturized rotatable tip strakes (Ng and Malcolm 1991(b)) for forebody control. Simple bodies of revolution through full configuration models have been tested with various control strategies.

As a summary view of the forebody technologies, nose strakes can be used (if strategically placed) to control the magnitude and direction of forces associated with vorticity. The blowing technique proved most effective when implemented near the dominant vortex and directed downstream. Blowing could effectively switch the sign of the yawing moment and was a function of mass flow coefficient. Forebody blowing on a slender cone suggested a preferred injection of fluid normal to the geometric surface; however, this preference changes with the objective of the control. Blowing through a slot near the nose is effective for controlling the vorticity field at a lower angle of attack compared with blowing through an orifice. Suction through a slot was noted to be effective if the slot was located very near the apex of the nose. Suction through orifices is effective in controlling the asymmetric forces at high angle of attack and appears to be a function of mass flow rate rather than momentum coefficient. Finally, moving strakes were investigated in wind tunnel experiments. Although equivalent authority can be gained with a single nose strake, the rotatable strakes can vary the asymmetric vortex field. The level of forcible symmetry or asymmetry with rotatable strakes is a function of the angle of attack.

Free-flight investigations employing blowing on the forebody of a generic fighter configuration have demonstrated effective control with an active approach (Brandon et al. 1996). Forebody control

technology moved from body of revolution type configurations to chined forebody applications. Blowing through an orifice or a slot on a chined forebody fighter configuration could produce yawing moments twice that of the rudder (Rourke and Sedor 1995; Rourke 1995).

Finally, a series of experiments by Roos (1993, 1996a and b, 1997, 1998, 1999) moved from stationary and steady forebody control techniques to oscillatory zero-net-mass synthetic jet-like forebody-control investigations. Microblowing proved effective when the orifice location was near the maximum flow instability, making the approach sensitive to placement. Microblowing on a hemisphere cylinder led to a reverse in the sign of the force compared with the same placement on a slender nosed model. Finally, based on the low-speed wind tunnel experiments, the zero-net-mass synthetic jets have been shown to be as effective as steady jets with the same average mass flow injection for controlling the flow (forces) in the forebody region of a hemisphere-cylinder forebody. The amount of authority of the synthetic jet control was a function of the maximum mass flow emitted from the device.

3.7. Wingtip Control

Some research has been successfully accomplished to show that wingtip blowing can lead to enhanced lift forces; hence, we will briefly comment here on those results because those activities fit within the scope of flow control.

Although some early work with wingtip flow modifications involved using passive fairings (e.g., winglets), we begin with the 1980s work of Wu et al. (1983, 1984) wherein wind and water tunnels were used for the experiments. Discrete wingtip jets were used to study the interaction of the jets and wing flow fields. The results suggested a favorable lift increment by using the jets, along with a dispersion of the wake vortex. The mass flow coefficient for those studies ranged from 0.001 to 0.01 and the jet angles were directionally varied for the study.

Lee et al. (1986, 1989) analyzed their wind tunnel results of a wing with lateral jet wingtip blowing and found a simple scaling between the mass flow of the jet, the angle of attack of the wing, and the resulting performance increment. Essentially, the blowing mass coefficient divided by angle of attack (C_{μ}/α)^{2/3} was found to be proportional to the lift increment. The scaling was observed to fail when secondary vortices appeared in the near wake.

3.8. Flow Control Application Remarks

When this overview of flow control technology was initially proposed there was the expectation of being able to extract from the literature sufficient information to give the research community a useful summary document. However, the task has proved challenging because of diversity in the experiments, measurements, results, and conclusions published and a vast number of publications in each flow control technology. Nevertheless, an important characteristic should be emphasized: many of the technologies, although technically feasible, have not been incorporated in a production application for economical, operational, infrastructure, or other nontechnical reasons (Bushnell 1997).

The technologies that have reached a high level of readiness are primarily passive device concepts. Clearly, vortex generators and natural laminar flow (on general aviation aircraft) have been incorporated into production configurations. Riblets are being tested on an operational aircraft, and polymers are being used in oil pipelines for drag reduction. Thrust vectoring with turning vanes is one of the few active flow control technologies to reach production-level readiness.

Looking to the future, other technologies discussed in this paper may achieve successful incorporation into civilian or military production configurations only after adequate design tools are available for the flow control technology or after larger scale testing yields higher technology readiness of the technology. Of course, some of the flow control technologies may reach sufficient technology readiness for a military configuration such that the initiative may potentially become classified.

Drawn out by this study, it is clear that as the technology becomes more sophisticated (active versus passive), the benefits must be sufficiently high to warrant the additional risk of a more complex system. That risk is not necessarily technical but rather financial. New complex systems lead to uncertainty in estimating manufacturing, operational, and overall life cycle cost to the new configuration. If uncertainty is too high (e.g., laminar flow control) versus the benefit margin, then the technology will not reach a production application.

4. Noise Control

Noise emission has been an important aspect of aircraft design during the past few decades and will continue to remain so throughout the foreseeable future. Following the mandated phaseout of Stage II airplanes in the year 2000, only Stage III compliant fleets will remain in civil aviation. These designations of noise certifications are derived from FAA regulations (Federal Aviation Administration 1985). The Stage III fleets are already about 20 dB quieter than the first turbojet powered airliners. However, as illustrated in figure 4.1, much of this reduction was obtained in the earlier years as engines moved from turbojet to turbofan cycles. The subsequent pace of noise reduction has been noticeably slower in comparison. Yet, the negative impact of noise on airport communities (coupled with a steady growth in air transportation) continues to drive public demand for an even quieter air transportation system (Powell and Preisser 1999).

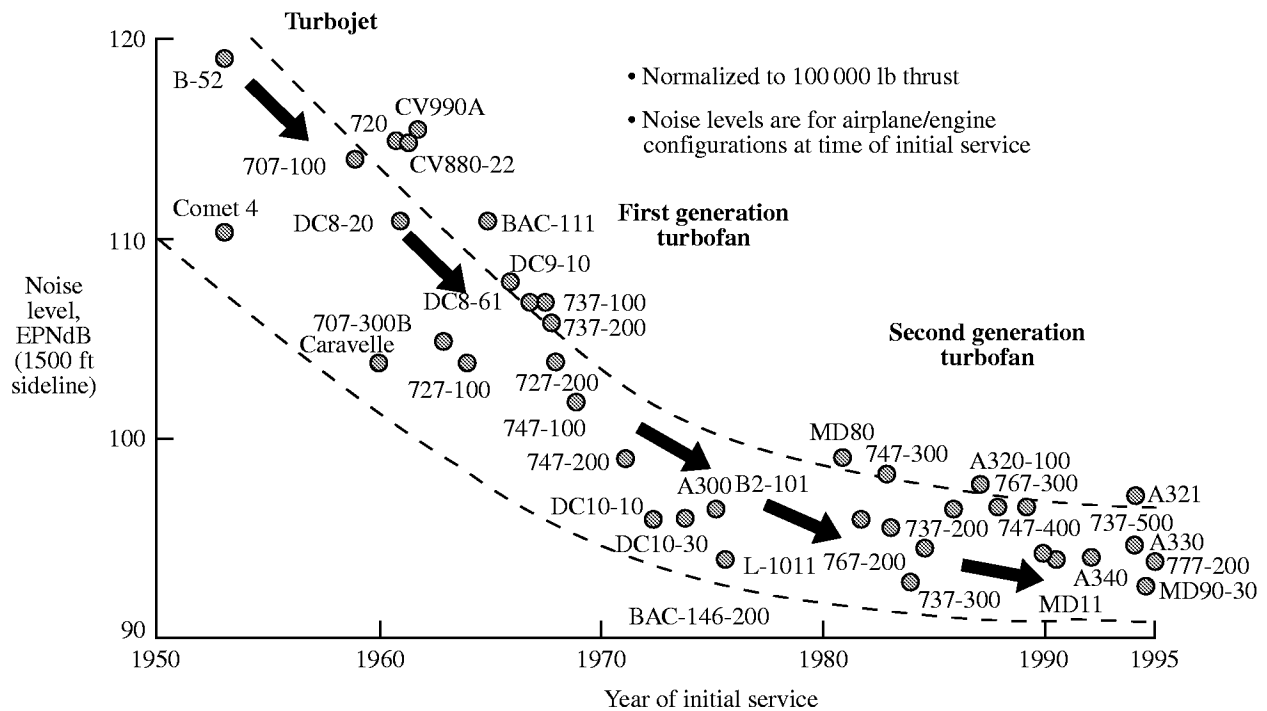

Figure 4.1. History of sideline noise levels at time of aircraft certification (adapted from Condit 1996).

In the U.S. about 500 000 people still live within the 65 day-night level (DNL) contour. Noise above the 65 DNL is considered unacceptable. The DNL description of noise takes into account the effect of noise over a 24-hour period where nighttime noise is considerably more objectionable. This is true in many other countries; for example, up to 15 percent of the European population is affected by aircraft noise due to densely populated cities (Ott 2001). However, noise also has a subjective component and communities in a wide area around airports can continue to complain of noise even though it has been reduced by containing the 65 DNL within the official airport boundaries (Bond 2001). Accordingly, new Stage IV regulations have already been under development for several years. Although the specific noise reduction targets and the time frame for their implementation are scheduled to be completed in 2001, it appears that the additional noise reduction mandated under Stage IV could be as high as 8 to 14 EPNdB (effective perceived noise) on a cumulative basis (including all three certification points) (Bond 2001). These standards would apply to certification of new aircraft. Also of significant impact are proposals to phaseout or retire the noisiest of Stage III aircraft. Various proposals before the International Civil Aviation Organization are estimated to cost in a range of up to 100 billion dollars, emphasizing the economic impact of aviation generated noise.

Anticipating this trend to continue well into the twenty-first century, NASA has set an aggressive goal of performing research and demonstrating technologies for reducing aircraft noise levels by another 20 EPNdB over the next 25 years. Such dramatic reductions are absolutely necessary to allow for projected growth in air traffic while ensuring compliance with increasingly stringent community noise standards around the world. To illustrate the impact of such reductions, even a 10 dB reduction will only limit the 65 DNL to within the airport boundary for U.S. airports. Continued reductions in interior (i.e., cabin) noise are also warranted by the need to improve passenger comfort, reduce crew fatigue, and thus enhance the safety of air travel. For military aircraft, on the other hand, the primary drivers for acoustic reduction are related to the requirement for minimum detection at close range and the minimization of sonic fatigue.

Two critical needs toward achieving projected noise reduction targets are addressed in the present section: (1) better understanding and prediction of noise generation and propagation mechanisms for all significant noise sources, and (2) noise reduction concepts that are both technically feasible and economically as well as operationally viable. Related considerations that would help meet the above needs, such as facility enhancements, advances in measurement techniques/instrumentation, concurrent research methods, and emerging technologies such as nanotechnology are discussed in the subsequent sections. It should be noted that the present overview is not all-inclusive, important topics such as propeller noise, engine core noise, and rotorcraft noise have not been specifically addressed in this document. Additionally, a number of successful noise reduction techniques of a proprietary nature have been omitted.

4.1. Exterior Noise

4.1.1. Turbomachinery Noise

The overall noise signature of subsonic transports with modern, high-bypass ratio engines is dominated by turbofan noise. The principal source of tonal noise from a modern turbofan operating at subsonic tip speeds corresponds to interaction of coherent parts of fan wakes with downstream stators and struts. Broadband noise sources include fan self-noise as well as interaction of blades and vanes with inflow turbulence, vortex ingestion, inlet boundary layer, and wake turbulence (Ganz et al. 1998). This entire process from flow disturbance with a blade surface to far-field directivity is schematically depicted in figure 4.2. An excellent overview of turbomachinery noise is contained in Groeneweg et al. (1991)

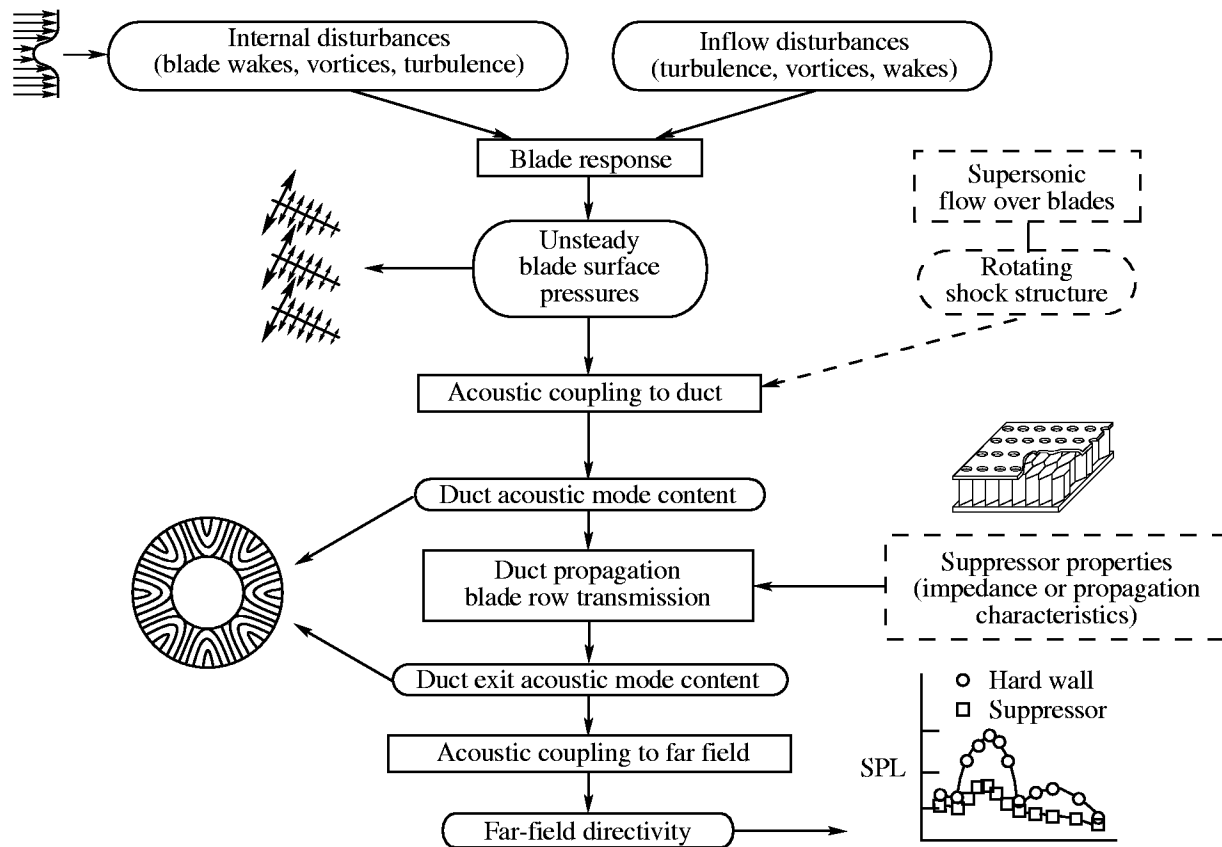
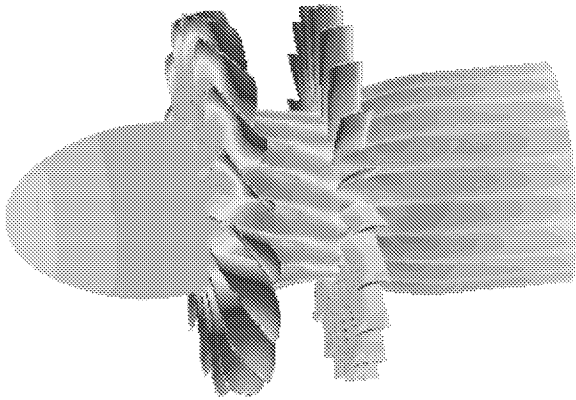

Figure 4.2. Turbomachinery generation and propagation process (Groeneweg et al. 1991).

and more recent reviews of progress in fan noise reduction specifically during the NASA Advanced Subsonic Transport program are provided by Envia (2001) and Raman and McLaughlin (1999).

A primary component of predicting interaction noise involves the scattering of a specified vortical gust (as a model for fan-wake nonuniformities) by the vane (or blade) row, which is typically approximated in engineering prediction tools as a quasi-2D, flat-plate rectilinear cascade. In practice, however, real blade effects (i.e., finite thickness/camber, aeroelastic motion) and annular geometry effects coupled with transonic flow speeds can produce significant deviations relative to predictions based on the flat-plate model (Huff 1998). Similarly, a generic specification (based on empirical correlations with wake measurements) for the vortical gusts can lead to errors of ± 3 dB or larger in predictions of the far-field acoustics. Both of these shortcomings can eventually be overcome by using a combination of steady CFD based on Reynolds Averaged Navier-Stokes (RANS) equations to provide wake profiles for a specific fan geometry and computational aeroacoustic methods to compute the cascade aeroacoustic response.

The alternate possibility of performing unsteady Navier-Stokes computations that include both the fan and the stator has also been demonstrated (Rangwalla and Rai 1993; Rumsey et al. 1997) (see fig. 4.3) Admittedly, routine applications of primarily numerical approaches will require quantum leaps in the accuracy and efficiency of numerical algorithms and/or the present computing capabilities. However, by virtue of providing detailed physical insights, which would be hard to obtain otherwise, methods of this type will play an increasingly valuable role in identifying and optimizing new concepts for noise reduction as discussed in the section on concurrent research methods.



(a) Total pressure contours.

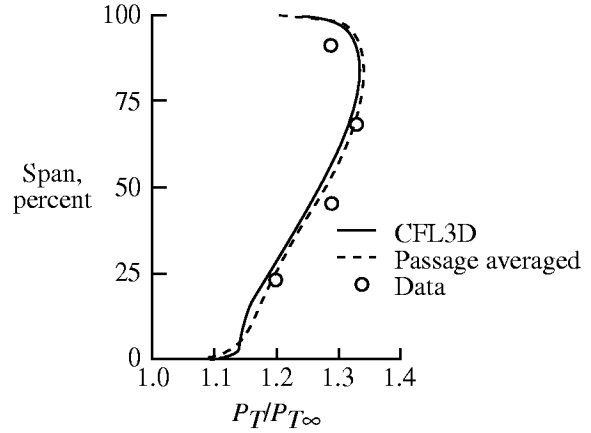

(b) Comparison of passage averaged CFL3D result with both experimental data and prediction based on average passage equations.

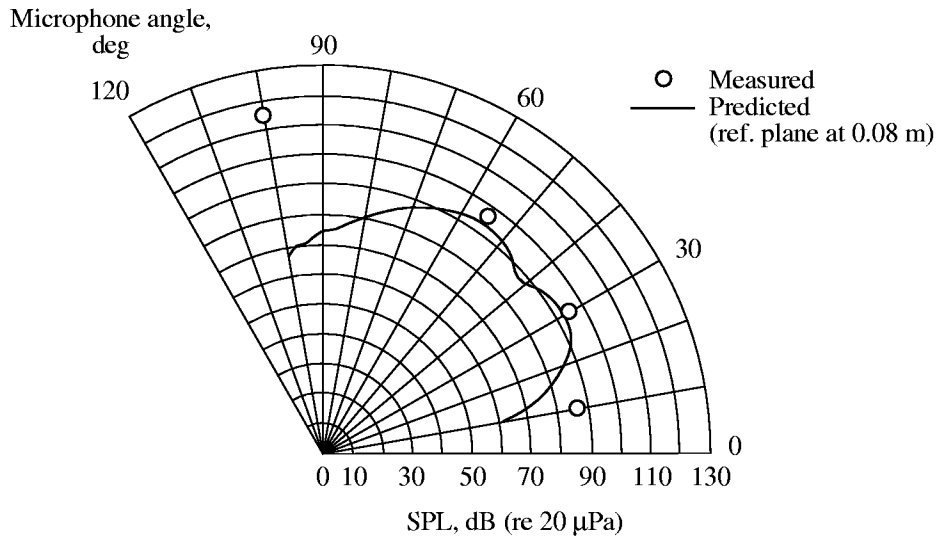

(c) Comparison of computed near-field acoustic directivity with measurements (Rumsey et al. 1997).

Figure 4.3. Navier-Stokes modeling of aeroacoustics of advanced ducted propulsor (ADP) model with 16 rotor blades and 20 exit guide vanes. Rotor speed is 16 900 RPM and axial Mach number is 0.2.

Another great benefit from applying computational approaches to turbomachinery noise problems is their potential to make integrated noise predictions involving a tight coupling between all relevant subelements of the turbomachinery noise process. System level predictions of this type would enable a more accurate assessment of the importance of physical phenomena such as mode trapping due to swirl, frequency scattering and transmission through the fan, and frequency scattering/reflection at the inlet and the nozzle. Recent work has shown that these coupling issues can be significant over a range of speeds and can affect both magnitudes and directivity of the far-field noise. Already, integration of RANS CFD (used for source prediction) with computation aeroacoustics (CAA), boundary element method (BEM), and finite element method (FEM) predictions (for duct propagation and inlet radiation) has been completed to achieve far-field predictions in a seamless manner (Rumsey et al. 1998; Farassat 2000).

However, there is also a need for sufficient parametric studies to distill an increased physical understanding regarding the coupling issues and to reveal the precise limitations of the simplified methods that have been used hitherto.

As a result of the progress made in predicting and controlling tonal content of turbomachinery noise, broadband noise has become an additional current focus of research and represents the primary barrier to understanding the main physics of turbomachinery noise generation. Also contributing to the increased significance of broadband noise are the downward shift in tonal frequencies (i.e., away from the range of peak auditory sensitivity) and a shift higher in the broadband spectrum, resulting from the trend toward larger diameter engines, smaller number of blades with wider chord, and lower tip speeds (Ganz et al. 1998).

Recent work at Boeing (Ganz et al. 1998) and elsewhere (e.g., Glegg and Devenport 2000) has just begun producing the kind of insights necessary to develop a satisfactory understanding of the broadband noise phenomena. There is a strong need to continue detailed measurements of the turbomachinery flow field and also to initiate accompanying numerical simulations. These steps will be necessary in order to pin down the precise nature and hierarchy of the various sources involved so that more effective noise reduction measures can be first identified and tested, then eventually optimized. There is also a significant opportunity to exploit the physical similarities between broadband fan noise and airframe noise in this respect. An example is the recent innovative application of the Brooks et al. (1989) data (which was originally obtained in the context of rotor/airframe noise) toward the prediction of broadband fan noise (Glegg and Jochault 1997). The same example also underscores the importance of conducting detailed experiments on building block configurations.

One of the main features setting noise control apart from flow control is that noise control measures can, in principle, be implemented anywhere from the noise source to the receiver (i.e., fig. 4.2 for turbomachinery noise). Flow control devices, in contrast, are generally confined to the vicinity of the flow feature to be controlled. An important exception to this rule is the process of laminar-turbulent transition, which is typically controlled by modifying the excitation of instability waves that occurs significantly farther upstream of the transition onset location. Thus, fan noise can be reduced by directly attacking the noise sources, through attenuation in the duct before the noise can escape the nacelle, or through shielding by the airframe en route to the receiver.

4.1.1.1. Source Level Control

A common approach for fan noise reduction involves geometric modifications that influence the kinematics of rotor-stator interaction, such as a change in blade/vane count (so as to cut off the dominant acoustic modes) or orientation (i.e., stator lean and sweep, which can yield a combined reduction of around 3 EPNdB). An increased axial spacing between the fan and stator vanes has the obvious effect of reducing wake strengths at the vane location. However, this approach carries a significant weight penalty, especially in view of the lower length-to-diameter ratios accompanying higher fan bypass ratios.

A more promising concept for directly altering the mean wake characteristics uses trailing edge blowing, representing an example of noise control directly from flow control. This approach has been shown to reduce the tonal noise via rotor-wake stator interaction by up to 4 dB (Brookfield and Waitz 2000). A small amount of air is channeled to the trailing edge through narrow passages in the fan blade (fig. 4.4). The passages in the hollow fan blade distribute air over the length of the trailing edge for injection.

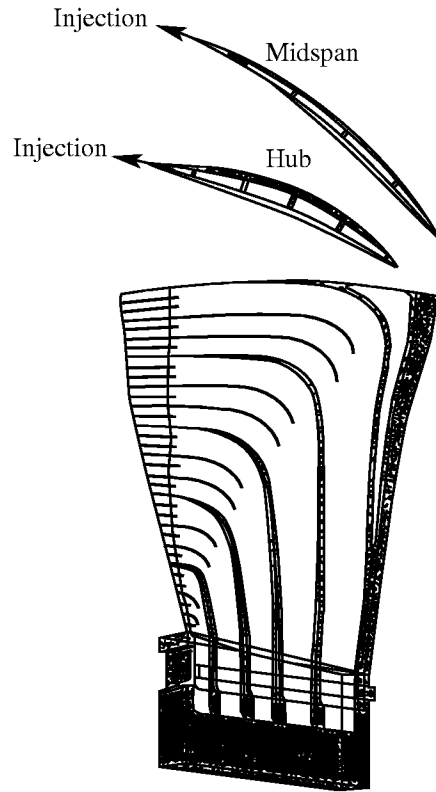

Figure 4.4. Cutaway of fan blade with trailing edge blowing (from Brookfield and Waitz 2000).

Injected air reduces the strength of the rotor wake by filling in the wake, thus greatly reducing unsteady pressure fluctuations on the stator downstream. Even with presumably little performance penalty, trailing edge blowing must still contend with similar issues as laminar flow control (i.e., need for plumbing, maintenance issues, etc.) before it can be applied on actual turbofans. Further development of the trailing edge blowing concept is required to assess its potential.

Yet another avenue for source level control of fan noise, which was also explored during the Advanced Subsonic Transport program of NASA, uses active sources mounted on a cascade surface, altering the unsteady pressure characteristics, to produce a weaker coupling with propagating duct modes. Both the plurality of duct modes at each tone and the number of tones would, however, limit the potential benefit from such active control approaches to a few dominant modes, and one challenge would be to minimize spillover from the control input into modes not targeted for control. A recent effort demonstrated significant progress toward this strategy by mounting piezoelectric benders as actuators on the stator vane surface. Control of the first harmonic fan tone was accomplished with reductions of 6 dB in the inlet and 4 dB in the exhaust directions (Sutliff et al. 2000). Reduction obtained with the system was found constrained by both the power amplifiers and the control spillover. While the stator actuators in this work performed well in general, a significant remaining challenge is to develop more powerful yet compact and practical actuator designs with higher limits on their amplitudes and frequency responses.

4.1.1.2. Control at Propagation Level

Source level control of turbomachinery noise sources is generally inadequate or impractical. Following the success of NASA's Quiet Nacelle program in 1967, additional noise damping has been achieved

through continued development of acoustic treatment panels (liners) mounted in both inlet and exhaust ducts of the engine. Current state of the art in duct acoustic treatment involves locally reacting, resonantly tuned absorbers based on arrays of Helmholtz resonators. Recent advances in acoustic propagation codes have allowed optimization of liner placement, such as the extension of treated surface to the inlet lip (Dougherty 1996) and liner optimization in curved exhaust ducts via segmented impedance distributions (Dougherty 1999).

Liner technology for engine nacelles within the next 10 years is expected to be driven by the need for increased suppression efficiency and bandwidth (due to limited area available for treatment as a result of engine designs with lower length-to-diameter ratios) while minimizing fabrication/installation costs, mechanical complexity, weight, and maintenance. Advancements are expected to proceed along three avenues: (1) further development of conventional liners, (2) impedance measurement technology improvements, and (3) innovative liner concepts. Further development of conventional liners will focus mainly on improvement of impedance prediction models for multilayer liners. Because current prediction models tend to be heavily empirical in nature, improvements must rely on achieving greater accuracy and precision in impedance databases (thus the need for improved measurement technology) and attaining a better understanding of the fluid dynamical processes through numerical simulations.

Innovative liner concepts may involve either self-adjusting (e.g., smart) liners based on microelectro-mechanical systems (MEMS) technology or a conventional, passive liner with in-situ control of an impedance regulating parameter such as bias flow across the liner perforate. Bias flow includes the blowing or suction of flow through an acoustic liner as shown in figure 4.5. While bias flow has been shown to control liner impedance (Dean 1976), more recently it has been studied as a possible means for improved broadband absorption (Cataldi et al. 1999; Follet et al. 2001). An option like the bias flow opens up the possibility of controlling boundary layer flow simultaneously with noise control. Unlike laminar flow control on external aerodynamic surfaces, insect debris is not expected to pose an operational constraint for the deployment of bias flow. However, other important considerations (such as plumbing and power

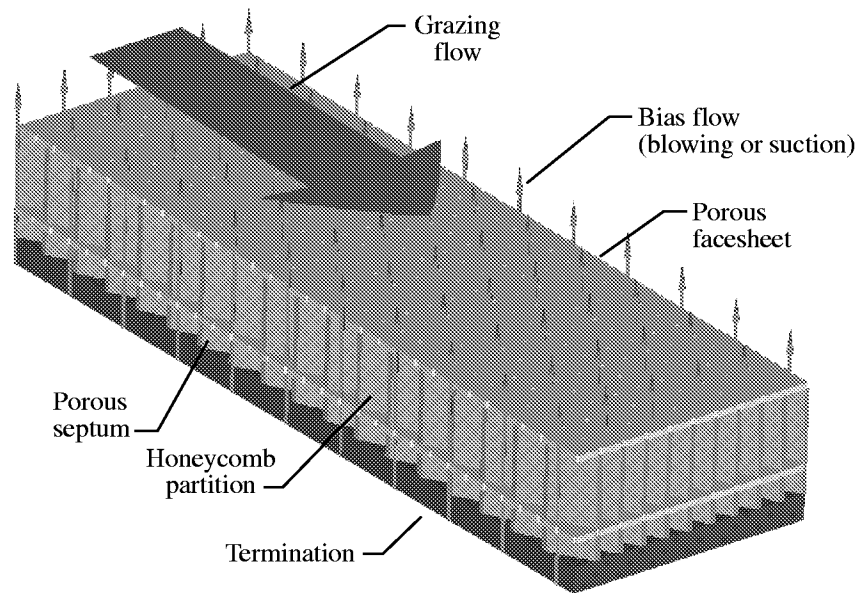

Figure 4.5. Two layer acoustic liner with bias flow (from Follet et al. 2001).

requirements to supply the bias flow) will have to be considered even after the technical merits have been established in a conclusive fashion. Finally, novel applications of previously well known concepts, such as Herschel-Quincke tubes, are also being pursued for propagation level control of engine noise.

4.1.2. Jet Noise

Since the first commercial turbojets were introduced into service following World War II, jet noise levels from subsonic transports have been reduced substantially. This decrease in jet noise represents the combined outcome of extensive research into jet noise suppression and increased engine bypass ratios (which led to reduced jet velocity and, hence, to lower noise intensity). Latter developments in the engine cycle also produced greater propulsive efficiency and reduced fuel burn. Thus, engine noise has been reduced simultaneously with greater fuel economy. Even so, jet noise remains a significant source of noise during full power takeoff, especially for derivative growth airplanes that require larger levels of thrust from the same engine. Therefore, continued advances in jet noise reduction are necessary if the long-term goal of 20 dB reduction in total aircraft noise is to be met. Jet noise has also been a major stumbling block in the development of supersonic transports, in addition to being a hindrance to the widespread acceptance of jet powered general aviation aircraft.

It is known that noise from supersonic jets tends to be dominated by large-scale unsteady flow structures and, hence there has been some success at noise prediction using instability-wave models (Tam 1991). For overexpanded or underexpanded jets, interaction of these large-scale structures with the shock cells leads to an additional source of broadband noise. Upstream propagation of this noise and the ensuing receptivity of the shear layer near the nozzle exit lip can establish a feedback loop, which leads to an additional source of noise: resonant screech tones at selected frequencies.

In contrast, the underlying physics of noise generation at subsonic jet speeds is not well understood. In principle, Lighthill's acoustic analogy (Lighthill 1954) provides an elegant means to connect the unsteadiness in the jet to far-field sound. Unfortunately, predictive use of the acoustic analogy is contingent on availability of detailed turbulent statistics (i.e., fourth-order space-time velocity correlations), which are difficult to measure or compute. Typically, various ad hoc assumptions have been made to enable jet noise predictions in an engineering context (Gliebe et al. 1991). The current belief is that, even though large-scale energetic flow structures dominate the mean-flow development and also control the rate of energy transfer to small scales of turbulence, the dominant source of jet noise is associated with somewhat smaller scales of turbulence. However, given the tremendous difficulty in either measuring or computing the small-scale structures, there has been no direct evidence to support this belief.

Clearly, the capability to measure, process, and extract the missing statistical information will represent a major breakthrough toward improved understanding, prediction, and hence reduction of subsonic jet noise. Such a breakthrough could be enabled by a benchmark experiment that would measure and document all essential information pertaining to the time-averaged flow field, jet turbulence characteristics, and the radiated acoustic field. To be of maximum practical value, such an experiment will need to be carried out (at least) at a large model scale, and with a dual-stream, high-speed, heated jet. The instrumentation system used would be the key in being able to make the necessary time-resolved measurements of turbulent fluctuations, including all three components of the unsteady velocity, temperature, and density fluctuations. These measurements would have to be global in nature and would require faster processing, probably with some key turbulence statistics processed in real time for active control systems. Simultaneous time histories of the far-field acoustic field would need to be acquired as part of such an experiment. Measurements of upstream turbulence in the plenum of the jets would be

another essential ingredient, one that will serve to both quantify the incoming flow and provide the desired boundary data toward numerical simulations.

A breakthrough experiment of this kind represents a daunting task at present, requiring significant further advances in instrumentation technology both in terms of hardware development and its implementation in the environment of high-speed, heated jets. Seiner's work (1998; 1999) based on planar measurements with a particle image velocimetry (PIV) system, represents a first step in this direction. Recent results based on Rayleigh scattering (Seasholtz and Panda 2000) also indicate promise for measuring velocity fluctuations as well as density and temperature fluctuations. A very attractive feature of Rayleigh scattering is that it uses molecular scattering rather than scattering light off seed particles as required by PIV. Continued development along these lines could enable the modern benchmark experiment on jet noise within a 10-year period, following which it could be extended to more complex jet configurations including the effects of airframe installation. Coupled with concomitant breakthroughs in actuator and sensor technologies, this would likely enable the development of a range of active control strategies and improved jet noise prediction methods. In general, present jet noise predictions are based on an experimental databank, with theoretical methods used to guide interpolation and, in some cases, extrapolation of the measured data. The new approach would facilitate a primary role for (physics based) computational techniques that have been calibrated against experimental databases.

Crucial to the above development would be the ability to perform numerical simulations of jet noise. During the past decade, there have been several exciting developments across a broad spectrum of prediction methodologies for jet noise. These developments include engineering methods based on a steady RANS solution for the jet mixing region (Khavaran et al. 1994) as well as numerical techniques based on direct numerical simulation (DNS) and large eddy simulation (LES) computation coupled with an accurate noise propagation scheme such as some form of Lighthill's acoustic analogy or DNS itself (Mankabadi et al. 1994; Mitchell et al. 1995; Freund, Lele, and Moin 2000). Good progress is currently being made with CAA techniques, such as involving screech simulations, that were able to duplicate many of the features observed experimentally (Shen and Tam 1998).

Currently, CFD methods are well-positioned for predicting the mean flow field in the turbulent flow of static circular jets at high Reynolds numbers over a range of jet exhaust Mach numbers and exit temperatures, as well as in jets of more complex geometry. However, for the purpose of noise prediction, further work is required to provide both steady and unsteady predictions under flight conditions, which would include the aerodynamic and acoustic effects of interference between the jet and the aircraft surfaces (i.e., scattering of jet noise by the wing trailing edge). Overall, it is important to extend calculations to provide good resolution in the frequency range, full scale from 2 to 15 kHz, to provide accurate data for the prediction of aircraft noise in units of EPNdB. The predictions for takeoff and landing need to cover a range of altitudes and angles in the flight plane from 0° to 180°, and to cover combinations of jet and flight speeds. Of particular importance are the spectra at various angles in the flight plane and for nonaxisymmetric jets in azimuthal angles. This presents a great challenge for laboratory measurements and for computer simulations. It may be this objective cannot be completed with the use of only a steady RANS flow solver. Nevertheless, the goal should be a fast flow solver that provides the mean flow data as well as distributions of the turbulent kinetic energy and the length scale of the energy containing eddies, combined with a filter function or the equivalent for the prediction of spectra and the SPL.

Because these approaches are focused on elucidating the underlying physics of jet noise, they represent the best foundation for further development of effective active noise control strategies. Long-range research of this type must, however, combine continued development of noise reduction strategies based

on physical reasoning, experimental tests, and computational prediction development. As discussed below, a few concepts have been proposed (and even validated) in this regard.

Currently established passive concepts for jet noise reduction include those based on geometric modifications such as multielement suppressors, ejectors, annular plugs, etc., as well as aerothermodynamic concepts involving an inverted velocity or temperature profile (Gliebe et al. 1991). With the exception of the inverted temperature profile, which serves as a thermal acoustic shield by refracting sound away from an observer or via multiple reflections within the jet, all of the above concepts reduce noise through a combination of enhanced mixing (i.e., rapid velocity decay, which reduces low-frequency noise), reduced characteristic jet dimension, or increased mean shear near the nozzle exit plane (which increases the high-frequency noise that is more easily attenuated via atmospheric absorption). Also, long duct mixed flow nacelles can add extra area for acoustic treatment application. While the acoustic merit of these concepts has been demonstrated, design tradeoffs against potential aerodynamic penalty and implementation issues, such as effect on cruise performance, must be considered while using such devices on real aircraft and have limited the application of most of these ideas.

An alternative class of passive devices for jet noise reduction involves trailing edge devices such as tabs (small protrusions at the trailing edge of a nozzle) that enhance mixing by introducing axial vorticity into the jet. For high subsonic jets at the model scale, tabs have shown reductions in peak noise levels; however, this is accompanied by an increase in high frequency noise. The result, when calculated in an integrated perceived noise level, relevant for full scale application, shows an increase in noise (Simonich et al. 2000). Yet, for supersonic jets, tabs (or roughness at the nozzle exit plane) are known to be effective in reducing the screech noise from imperfectly expanded supersonic jets by disrupting the feedback loop responsible for such oscillations (Tanna 1977). Other aspects of the understanding of screech, status of prediction capability, and reduction methods are thoroughly discussed by Raman (1999).

Another trailing edge device that has been developed in recent years is the chevron, which introduces longitudinal vorticity in the shear layer. Figure 4.6 shows the lobed pattern in a dual stream jet created by the vorticity introduced by chevrons on the core nozzle. Chevron devices have been shown to increase mixing (Kenzakowski et al. 2000) and to reduce noise by up to 2.5 EPNdB with minimal loss in performance (Saiyed et al. 2000). Considerable work will occur to optimize the performance, aerodynamics, and acoustics of the chevron; however, a greater fundamental understanding of the chevron mechanism is needed and, of course, would aid that optimization.

Another recently proposed concept for passive reduction of jet noise involves the suspension of a flexible filament in the jet mixing region. It is relatively easy to implement and has been shown to be quite effective in reducing both screech tones and broadband shock noise (Anderson et al. 1999). Other findings (albeit of a preliminary nature) suggest that filament suspension may not be as effective at subsonic jet speeds. Specifically, Simonich et al. (2000) found that reductions of 1 to 2 dB in the low- to mid-frequency range were accompanied by similar increases in the high-frequency range, leading to higher perceived noise levels for a few cases. Based on the mixed results obtained thus far, this approach warrants further investigation. For instance, the variability of noise reduction levels with filament characteristics (i.e., type, length, diameter, etc.) indicates that further work is necessary not only to clarify the physical role of the filament in noise generation, but also to optimize this concept more completely. Near-term investigations should focus on optimization efforts in the subsonic regime, using a combination of experiments and complementary modeling effort. Like many noise reduction proposals, it also offers a unique method of probing the physics of jet noise mechanisms that could lead to greater understanding if not an actual noise reduction device.

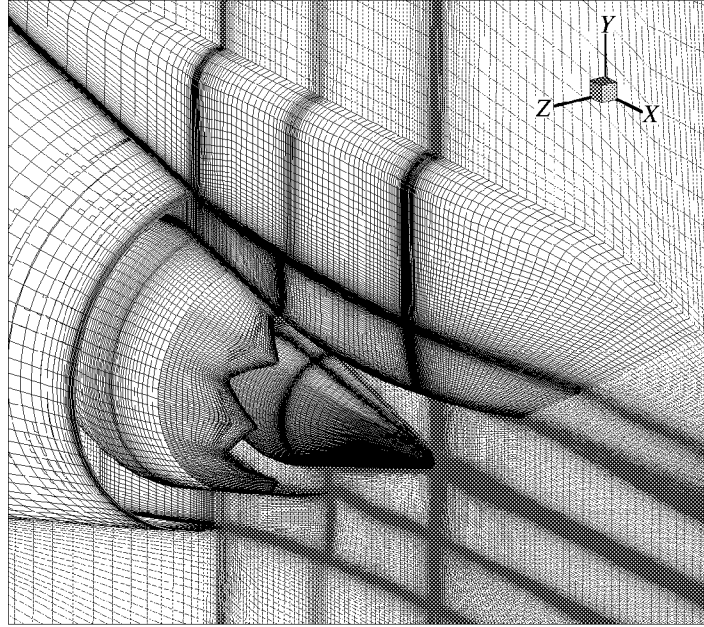

(a) Computational grid of a dual stream nozzle of bypass ratio 5 with eight core chevrons and a pylon.

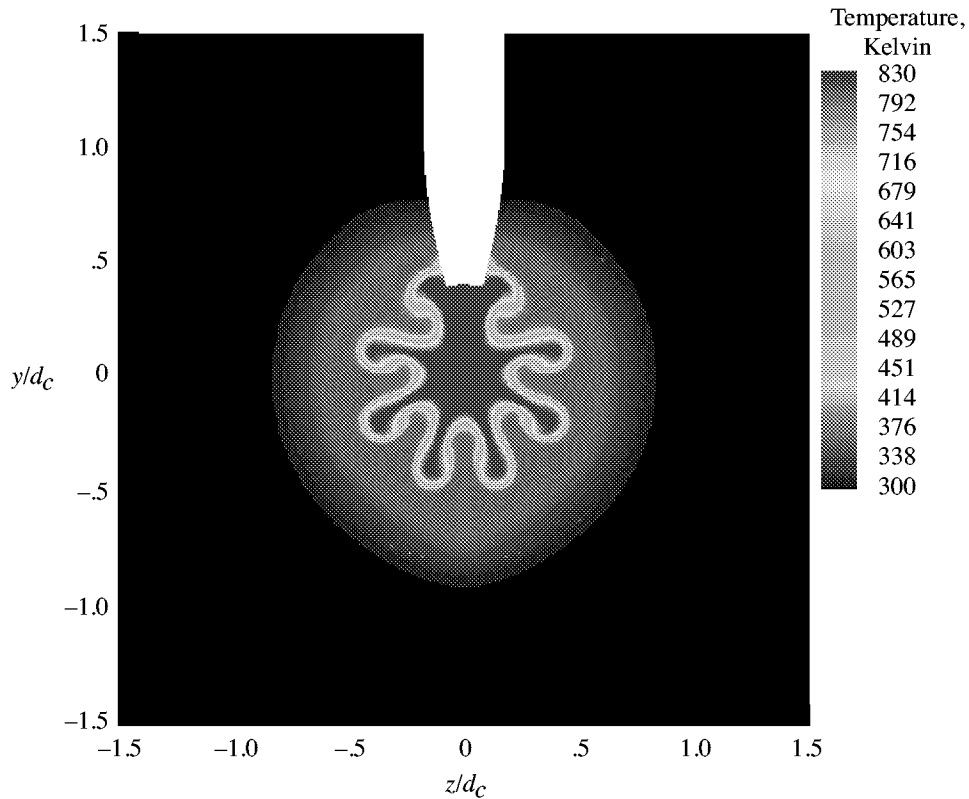

(b) Total temperature contours at an axial station of $x/d_c = 2$ where d_c is core nozzle diameter. Temperature color scale in degrees Kelvin.

Figure 4.6. Numerical simulation of dual stream nozzle flow with core nozzle chevrons (Thomas, Kinzie, and Pao 2001).

A novel application of active noise reduction aims to use water injection in small quantities to reduce supersonic jet noise (Krothapalli et al. 2000). This approach is predicated on being able to transfer a part of the turbulent kinetic energy in the jet to water droplets so as to reduce far-field noise. This particular mechanism is quite different from that of underlying previous investigations (Marble and Candel 1975) wherein extremely small water droplets (order of 1 micron) were used to attenuate fan tone noise through evaporation effects. Water injection in massive quantities has been routinely used for the reduction of jet noise from launch vehicles (Gély et al. 2000). For the rocket noise application, similar reductions have been obtained using the alternative technique of directing the exhaust gas into a body of water (Cole et al. 1960).

Due to the inherent need for water supply, transition of the water injection concept to real exhaust systems will be contingent upon tradeoffs between the quantity of water required and the extent of noise benefit derived. Nevertheless, coordinated analytical and experimental research on this topic will add to the current knowledge of source mechanisms responsible for jet noise, and also lead to the development of a practical suppression concept.

Active control of jet noise, via unsteady actuators mounted near the nozzle exit, is an attractive option from the standpoint of maintaining an optimal aerodynamic performance under a wide range of operating conditions. Despite its demonstrated ability to increase jet mixing, active jet flow control has generally proved unsuccessful at reducing noise and has actually increased far-field noise in some cases (Kibens et al. 1999). Active control of jet noise is clearly in its infancy and would require significant advances in actuation systems, control algorithms, and measurement techniques in order to realize its powerful potential. Glow discharge devices, Helmholtz resonators, MEMS, and fluidic injection are all actuation systems that indicate promise in controlling jet flow. In addition to addressing technical issues relevant to these forms of control, there is a general need to examine the robustness of such devices in the harsh environment of high-temperature jet exhaust. Due to limited access for sensors, closed loop jet noise control poses significant challenges. Because ongoing work on optical sensors may, however, remedy the need for remote flow diagnostics, there is a need to assess the relative noise reduction potential of closed loop control (in comparison to open loop techniques) in laboratory experiments.

Finally, keeping in mind the primary propulsive function of a jet, any research in jet noise must be intimately tied to performance considerations of the jet itself and also with the more complete view of airframe-propulsion integration as a whole. As with the study of any aerodynamically generated sound source, the study of jet noise must be synergistically linked to that of aerodynamics and fluid dynamics. Much more research is needed in the area of jet aeroacoustics to provide the required link between aerodynamic performance and the resulting acoustic characteristics that engineers need to make intelligent design decisions and produce aircraft systems that meet both noise and performance requirements. Radical breakthrough advances in jet noise and in the effects of integration of propulsion and airframe configuration will be required to contribute significantly toward the aggressive NASA goal of 20 dB in overall noise reduction.

4.1.3. Airframe Noise

With continued success in engine noise reduction, airframe noise has emerged as a potentially significant contributor to overall acoustic emissions, particularly at approach conditions. The dominant sources of airframe noise are known to be associated with unsteadiness of separated and/or vortical flow regions around the high-lift system (i.e., flaps and slats) and the aircraft undercarriage (i.e., landing gear) (Davy and Remy 1998). Due to the myriad of three-dimensional features that may contribute to flow

unsteadiness and the importance of surface geometry in scattering these vortical structures into sound, airframe noise is an extremely complex and challenging problem.

Airframe noise research during the 1970s focused mainly on trailing edge noise due to the scattering of boundary layer turbulence at the trailing edge of a wing, although simplified models for other sources, such as a flap side edge, had also been conjectured at that time (Crighton 1991). An important conclusion from the work of the 1970s is that, for a wide range of aircraft including gliders, overall airframe noise on approach (as measured at ground level immediately below the aircraft and after subtracting the estimated contributions due to engine noise and engine-airframe interference) is proportional to fifth power of the aircraft speed (Lilley, private communication, 2000). Had airframe noise been dominated by dipole contributions associated with unsteady aerodynamic loads on the aircraft, it would have instead scaled with the sixth power of the speed. Measurements during the seventies showed that airframe noise in a clean configuration (i.e., without landing gear and high-lift devices) was dominated by scattering of the turbulent boundary layer near the wing trailing edge. Under approach conditions, with the aircraft in its high-lift configuration, it is the pressure fluctuations near the flap side edges, the trailing edges of the slats, and the wake of the undercarriage passing close to the wing trailing edge that produce the major sources of airframe noise; each one of these sources is strongly influenced by the presence of a neighboring scattering surface.

Early work from the 1970s, especially results from flight tests of a large number of flyovers, generated a large noise databank that was used to provide an empirically based airframe noise prediction method. However, more recent theoretical and experimental work has established the need to replace the existing prediction method with a more accurate, physics based prediction for airframe noise. While this goal appears to be significantly futuristic, recent work has focused on developing the physical understanding necessary to formulate better engineering models. In particular, work during the 1990s led to significant physical insights into the detailed fluid dynamics of relevant unsteady flow structures and how they produce noise (Macaraeg 1998). This progress came about from a combination of new experimental and computational techniques used in parallel. Such enhanced understanding has also led to successful control concepts for airframe noise reduction on the laboratory scale (fig. 4.7). Although much of the noise reduction work will not be described here because of its sensitive nature, a comprehensive overview of the earlier work may be found in Storms et al. (1998).

A major focus of recent work on airframe noise has been on noise associated with the high-lift system, particularly on noise generation near a flap side edge. A combined NASA/industry team implemented an approach using a combination of detailed measurements and computations of the local flow field and the far-field acoustics. Detailed computations of the local flow include RANS computations that resolve the relevant mean flow features together with appropriately simplified simulations of large-scale fluctuations convected with mean flow features. The far-field acoustics are predicted either through a Lighthill acoustic analogy approach or by using the Ffowcs Williams-Hawkings equation. Using this type of approach, the NASA/industry team was able to correlate different parts of the far-field spectra to specific flow field features such as instability modes of the shear layer(s) associated with flow separation near the side edge, and edge vortices created by the roll-up of the shear layer (Macaraeg 1998).

Armed with a physical understanding of the noise sources involved, several passive edge treatments (such as a porous flap tip) were developed and tested. The result of the edge treatments was a reduction of 4 dB in a limited band of frequencies of noise resulting from the presence of vortices close to the side edge. The total reduction on the flap side edge would be less than this amount. A similar effort for slat noise led to the discovery that a prominent high-frequency hump in the slat noise spectrum is caused by vortex shedding from a seemingly sharp slat trailing edge (Khorrami, et al. 1999). The otherwise broadband noise was shown to be associated with unsteadiness of separated flow on the lower slat

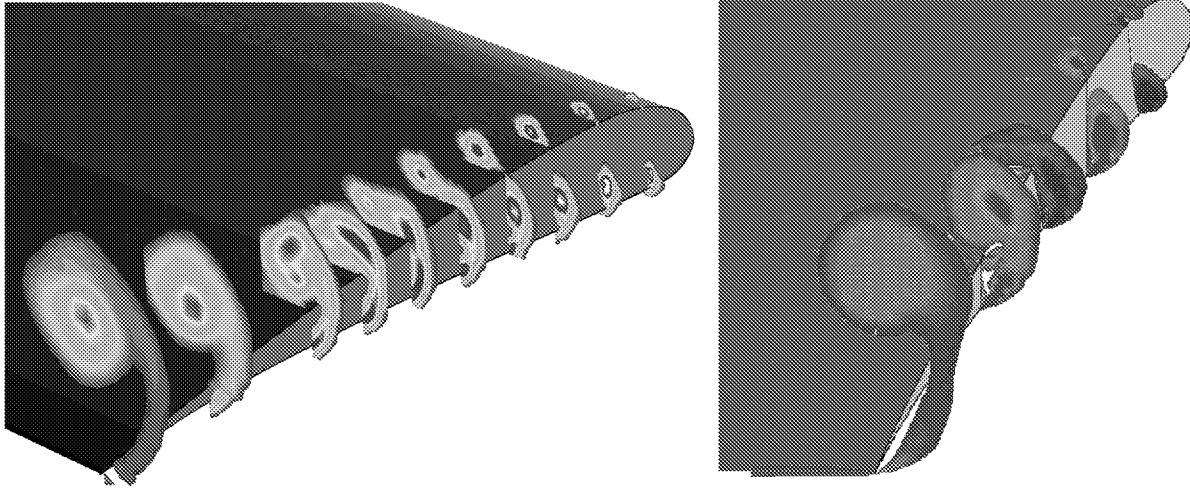

(a) Steady flow surrounding flap side edge (via experiment and CFD): axial vorticity contours at various stations along side-edge vortex (Streett 1998).



(b) Large-scale unsteady structures sustained by mean flow: snapshot of fluctuating vorticity contours at representative cross section through flap side edge (Streett 1998).

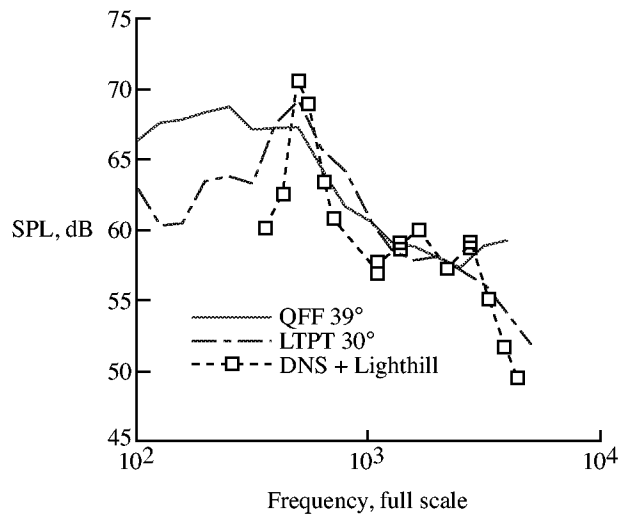

(c) Unsteady computation coupled with Lighthill Acoustic Analogy for far-field noise: comparison with experiments (NASA Langley Quiet Flow Facility (QFF) and NASA Langley Low Turbulence Pressure Tunnel (LTPT)).

Figure 4.7. Illustration of modern approach for airframe noise investigations.

surface—a finding that again helped with cutting noise levels by over 5 dB in the limited frequency bands associated with the particular slat flow.

While not yet examined in detail, other methods of potentially reducing flap/slat induced noise do exist. These include using steady suction (or blowing) to influence the location of strongly unsteady flow features (such as side-edge vortices, or reattachment location on the underside of a flap) relative to

geometrical inhomogeneities (i.e., surface edges and corners). A passive technique that appears well suited for practical application is to eliminate (or minimize the extent of) inboard side edges via flap geometry based on the continuous mold line technology (CMT) concept (Storms et al. 2000).

Acoustic measurement techniques based on novel microphone array configurations have played a crucial part in recent breakthroughs in airframe noise via identification of dominant noise source locations throughout the frequency range of interest. The array techniques will continue to be useful in future efforts at both further understanding and reducing the impact of various airframe noise sources. However, steps must be taken to rectify present limitations with respect to interpreting the array data, especially data obtained in hard wall (i.e., reverberant) tunnels and/or for coherent line sources. Notwithstanding, hard wall pressurized wind tunnels allow testing at closer to full scale Reynolds number—a desirable situation. Inclusion of CAA solutions into beam-forming algorithms used to process array measurements may help to cure these deficiencies and improve quantitative accuracy of the measurement technique.

Numerical simulations, both steady and unsteady, of the airframe flow field will assume an increasingly important role in the next phase of airframe noise research. However, detailed measurements of the unsteady source region will be equally necessary to validate such computations. While detailed flow maps inside the source region would be expensive, difficult, and less likely to come by, measurement of surface pressure fluctuations using arrays of MEMS based pressure sensors appears quite feasible and will contribute significantly to obtaining the higher resolution data.

Ongoing work on individual sources of airframe noise, in terms of both physical understanding obtained thus far and the underlying research methodology, will provide a strong foundation for investigating additional noise mechanisms. These additional noise generation mechanisms are associated with interactions created by the complete vehicle. For example, these interactions exist between multiple airframe components (i.e., interaction between the wake of a landing gear and the flap) and installation effects involving propulsion-airframe integration, including the interplay between propulsive noise sources and airframe components (i.e., jet interaction with a flap).

Similarly intricate interactions (albeit at a component level) are important for landing-gear noise, one of the least understood sources of airframe noise at this point. The geometry of a typical undercarriage system involves a number of bluff bodies (wheels, axles, struts, shafts) of varying shapes, sizes, and aspect ratios. While the relatively straightforward remedy involving streamlining of individual components has been shown to reduce undercarriage noise by 3 dB (Dobrzynski 2000), no other clues to achieve additional noise reduction are available as yet. Recent findings based on tests carried out in Europe (Dobrzynski and Buchholz 1997) emphasize the need for high fidelity modeling of the undercarriage geometry to capture noise generation throughout the range of audible frequencies. Additionally, this complex flow field, dominated by multiple bluff-body separation regions, may be sensitive to Reynolds number, hence requiring full-scale testing for gear induced noise. The ability to accomplish this difficult task in both laboratory experiments and computations will determine the success of future research on undercarriage noise reduction. Ambitious efforts toward this goal have already been initiated with computational and experimental efforts. Figure 4.8 shows results from unsteady simulations of a simplified landing gear model. The landing gear geometry is based on a 31-percent scale Boeing 757 main landing gear bogie that was tested by Lazos (2001) at the Basic Aerodynamic Research Tunnel (BART) of the NASA Langley Research Center.

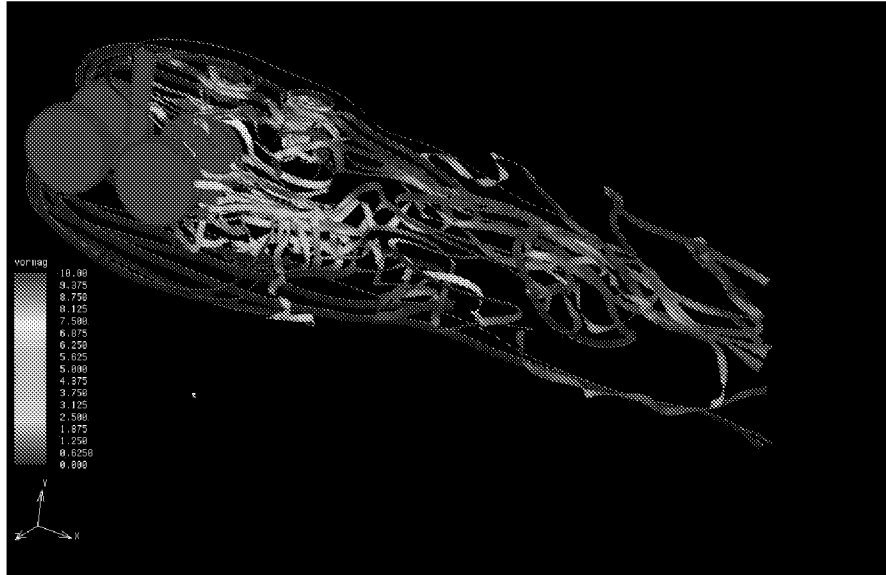

Figure 4.8. Snapshot of computed unsteady flow field around simplified landing gear model: instantaneous stream ribbons colored by magnitude of total vorticity (Hedges, Travin, and Spalart 2001).

4.1.4. Sonic Booms

Sonic booms present a unique component of noise pollution due to aerospace vehicles, both in terms of the nature of their environmental impact and the relevant prediction methodology. Together with jet noise, sonic boom impact has been a primary obstacle toward the development of supersonic transports. Also, sonic booms will continue to be relevant during the planning of military flight operations, whereas the primary driving factor on the NASA side will be an increased activity in space transportation.

As with other sources of flight related noise, sonic boom impact can be minimized either through vehicle design or through appropriate flight planning. As a result of relatively mature CFD techniques for steady supersonic flows, it is feasible to make reasonably accurate and fast predictions for the near- and far-field signatures of sonic booms for a given aircraft configuration as well as use this capability to optimize the overall design for a minimum adverse impact. An important deficiency of the current state of the art in sonic boom prediction, however, stems from the fact that the validation database (which was primarily acquired in the seventies) is limited to airplane configurations. Space vehicles represent a different class of geometries (with the added complexity of a strong plume for launch vehicles) and operating parameters, for which little data have yet been measured. An example of using flight planning to minimize sonic boom impact from space operations is to locate the launch sites in coastal regions (similar to primarily over-the-water routes for commercial supersonic transports). Unfortunately, this approach is not effective during landing of reentry vehicles.

Recent research has suggested a third, novel strategy for minimizing sonic boom amplitudes. It involves active mitigation either through unsteady maneuvering (so as to alter the effective source distribution in the near field) or via plasma control (toward reduced shock-wave strength). The pros and cons of both these approaches, including operational feasibility, are unclear at this stage.

Some of the outstanding issues in sonic boom research include prediction during accelerated flight, propagation through atmospheric turbulence, and development of metrics for human response to sonic booms. Researching psychoacoustic aspects of sonic boom effects on animals (terrestrial wildlife as well

as near surface ocean ecology) is a difficult problem that has been circumvented for the most part via a monitor-and-mitigate approach. Unlike above-ground signatures of sonic booms and focused booms, physical understanding concerning the underwater transmission of sonic boom overpressures below an air-ocean interface is severely lacking at present, causing great difficulties in assessing the impact of sonic booms on ocean ecology.

It may be noted that sonic boom represents just one of the many technical obstacles in developing a second generation supersonic transport. Other difficulties include noise certification, environmental issues, and economic viability. Clearly, development of fundamentally new flow and noise control technologies will create new options and capabilities that can potentially lead to an operationally viable design concept for a new supersonic transport. A sustained high-risk effort targeted specifically at the problems of supersonic transports is needed to produce the required breakthroughs.

4.2. Interior Noise

Although aircraft interior noise is not a noise emission problem, interior noise will enter the design equations as aircraft propulsion and noise emissions are reduced through the most direct way, weight reduction (see fig. 4.9). The mass of the aircraft structure acts as a shield against noise generated by external sources (boundary layer turbulence and engine noise). For example, if the fuselage mass is reduced by use of composite structures, then interior noise will increase, thus the need for noise reduction treatment. The most common treatment used for interior noise control is fiberglass insulation (which also provides heat insulation). Additional noise control can be obtained by treating the aircraft skin with constrained layer damping to reduce vibration. These treatments are most effective against broadband noise in the high (greater than 500 Hz) frequency range.

Turbomachinery noise tends to concentrate a great deal of energy at discrete frequencies in the low frequency ranges. Tuned vibration absorbers (TVA) have been used to reduce vibration levels, and therefore interior noise, at low, discrete frequencies; however, design and application of TVAs are done by trial and error. TVAs are heavy and prone to wear out prematurely due to intensity of the vibration.

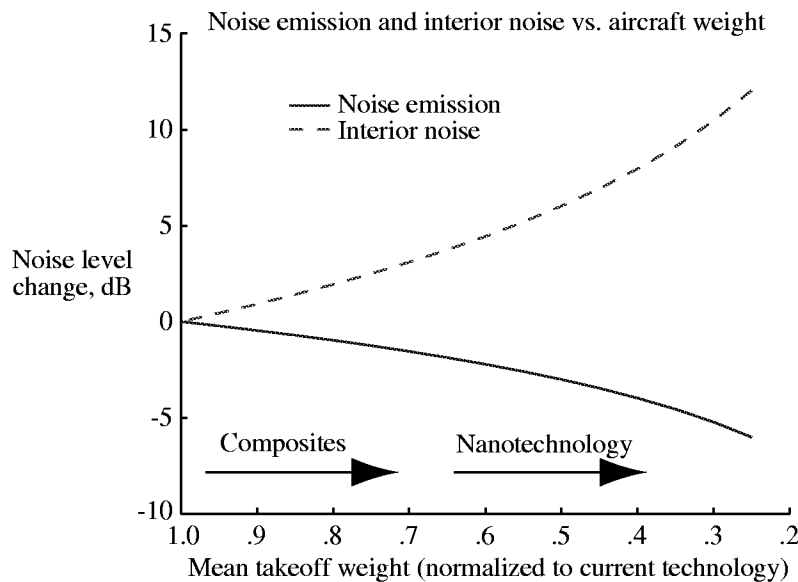

Figure 4.9. Dependency of emitted noise and interior noise with aircraft weight (Palumbo 2001).

Turbomachinery noise is multiharmonic with several harmonics contributing to passenger discomfort. Thus, several types of specially tuned TVAs would be required to treat a specific aircraft. There is also a tradeoff between the amount of control a TVA can achieve and the bandwidth of the device: greater control sacrificing bandwidth.

The noise control techniques discussed above can be classified as *passive*; that is, they require no outside power source. Good results have been obtained using *active* control techniques (Elliott 1999). These systems use microphone and accelerometer sensors, powered actuators (such as a loudspeaker), and digital signal processors (DSPs). Active control systems have been most effective on harmonic sources where the repetitive nature of the noise reduces processing requirements on the controller. Active control systems are in use in aircraft to reduce interior noise caused by propellers and turbomachinery; see figure 4.10 and Ross and Purver (1997).

Several areas represent opportunities for progress, centering on control strategies, design and material optimization, and measurement technology. Piezoceramic (PZT) material might constitute the preferred actuator if it had better response at the lower frequencies. With the proper material modeling tools, the PZT material, dimension, and shape could be optimized to provide this performance (Bevan 1998). Other approaches involve the combination of active and passive materials, such as acoustic foam to damp higher frequencies and piezoelectric material to actively control lower frequencies (Fuller, Johnson, and Griffin 2000).

Most active control systems use a centralized controller where distributed sensors and actuators are wired back to a single controller. The wiring adds cost, weight, and reduces reliability. A distributed control algorithm—where sensing, actuation, and control are localized—would not have these disadvantages. A distributed design would enable integration of device packaging, further decreasing cost and improving reliability. Active control of boundary layer induced interior noise may require the application

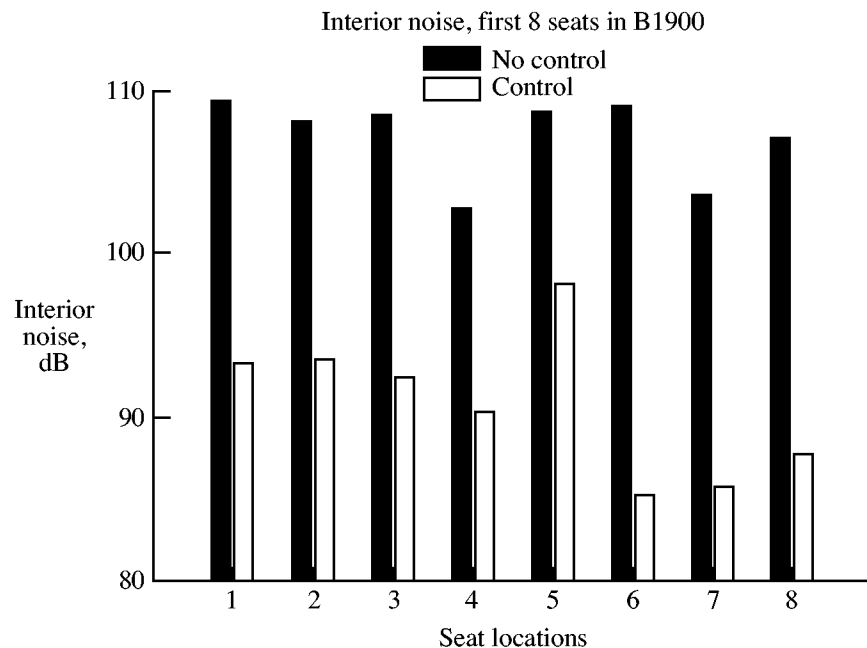

Figure 4.10. Noise reduction obtained in first 8 seats using active control in a Beech B1900 aircraft (typically a 19 seat aircraft, single aisle with nine rows) (Palumbo 2001).

of many independent controllers over a large area of the aircraft's interior fuselage surface (Griffin, Johnson, and Fuller 1998; Gibbs, Eure, and Lloyd 1999). This would be possible only if the controllers were inexpensive to produce and install. MEMS technology may be the method by which sensors, actuators, and controllers are all integrated in single autonomous units.

Once frequencies exceed 200 to 300 Hz, finite element models do not predict fuselage response very well. This is a major impediment to factoring noise reduction into the design process. Also, the methods and algorithms by which material properties are optimized to reduce noise transmission are largely experimental (Crane et al. 1997; Robinson 1999). This area has the greatest potential for reducing interior noise at the lowest overall cost because no additional weight or control system is necessary.

5. Synergy Between Flow and Noise Control

Prior experience has shown that for any newly identified noise source it is relatively easy to achieve the first few decibels of reduction in acoustic intensity. To achieve subsequent reductions in noise levels, however, an exponentially large effort—in terms of both research and cost of technique implementation—becomes necessary. The successes of prior noise-reduction programs (recently, the noise reduction element of the NASA Advanced Subsonic Transport (AST) program, which had a goal of an overall reduction of 10 dB relative to the 1992 technology) have already brought us to this regime of increasing degree of difficulty.

Given the need for continued noise reduction, however, extremely innovative approaches will be required to achieve projected targets during the next two decades. It is somewhat premature to speculate on what precisely these approaches would be; however, it is certain that any successful technique will necessarily stem from a deeper understanding concerning the physics of noise generation and propagation. Also, one can safely predict that as the dominant tones are successfully reduced using technologies developed during the Advanced Subsonic Transport program, further reductions in the overall noise spectra will be controlled by the various sources of broadband noise. A complete elimination of fan tones, for example, will yield an overall EPNdB reduction of only 2 dB, whereas additional reduction will have to be obtained via broadband noise control (Gliebe 1996).

Because of the origin of broadband noise in flow turbulence, advances in flow and noise control technologies will have to be increasingly synergistic. Given the impending revolution in flow control technology, this is almost a fortunate happenstance; a designer's responsibility, then, is to exploit the inherent synergies between the two so as to enable the development of radically enhanced, environmentally friendly aerovehicles. Such synergies could exist either at the modeling level (i.e., physical similarities between synthetic jet actuators and duct acoustic liners would permit parallel model formulations and overlapping design tools) or extend to the implementation level (i.e., microblowing can serve the dual purpose of reduced nacelle drag and acoustic impedance control).

Another example of the latter synergy is related to potentially successful deployment of LFC on a nacelle. Insect accretion has been a major obstacle toward commercial deployment of the LFC technology. Previous attempts to tackle this problem involved the application of insect-repellent coatings. Another alternative (derived from Boeing's recently patented concept of an anti-icing system for the nacelle inlet region) is to blow hot air through the porous LFC surface to incinerate the insect debris before reaching cruise altitudes, at which time the blowing would be reversed for suction to obtain laminar flow.

Historically, passive control techniques have dominated both flow and noise control worlds, with the control measure being implemented typically at a component level and, more often than not, on an *a posteriori* basis. This was required because typically expected performance did not materialize or because requirements or regulations changed at a later time. The past decade, however, has witnessed a changing of the guard in this area, with an increased emphasis on harnessing the hidden potential of active flow and noise control as implemented in a fully integrated, multidisciplinary framework.

Active techniques can be implemented in both open loop and closed loop fashion, but closed loop devices (i.e., with feedback) offer the maximum potential in terms of optimal overall performance. Control algorithms for linear, time invariant, fully deterministic systems are well established. However, high Reynolds number flow systems are inherently stochastic in nature, tend to involve a prohibitively large dimension (i.e., number of degrees of freedom), and more often than not, require a significant nonlinear coupling between the various states. Successful application of modern control concepts is, therefore, far from proven and will require significantly higher physical insights into the various flow systems that are encountered in aeronautical applications.

Efficient design of massively actuated systems, characterized by a large number of discrete or distributed actuators, will require tools to optimize the number and spatial locations of both sensors and actuators. There has been considerable research in a variety of disciplines on actuator and sensor placement, either to optimize the controllability and observability of the system or to maximize some objective function of control system performance. In addition, for adaptive control, the sensor and actuator locations must also be optimized for the accuracy of system identification.

CFD will play an increasingly valuable role in the development of both passive and active flow and noise control systems by generating the necessary insights to minimize costly experimental testing. For active systems in particular, computational methods will help establish required specifications (in terms of frequency response and amplitude range) for actuators and sensors, design effective actuation concepts that require minimum energy expenditure to achieve a desired control action, and choose the best locations for these. Numerical simulations would also serve as a useful test bed toward off-line assessment of the various control algorithms.

Consequently, technologies for developing radically new aerovehicles, which would combine quantum leaps in cost, safety, and performance benefits with environmental friendliness, have appeared on the horizon. Bringing their promise to reality will require an increasingly interdisciplinary approach, coupling further advances in traditional areas of aeronautics with intelligent exploitation of nontraditional/interdisciplinary technologies such as smart, distributed controls, novel actuators, and microelectromechanical systems (MEMS). Concurrent research methods will be an aspect of the increasingly required interdisciplinary environment that will be vital to this development as outlined in a following section.

In very fundamental ways, flow and noise control are becoming more closely linked. As described above, the synergies between the two areas are related to physical understanding and modeling of critical flow features, development of control strategies for broadband noise and turbulence, integration of passive and active control devices, efficient design of control systems, and the deployment of CFD techniques in the above areas. In the remaining part of this section, we further illustrate this symbiotic relationship in one specific context where significant fruitful developments have been demonstrated in recent years through flow and noise control using passive porosity.

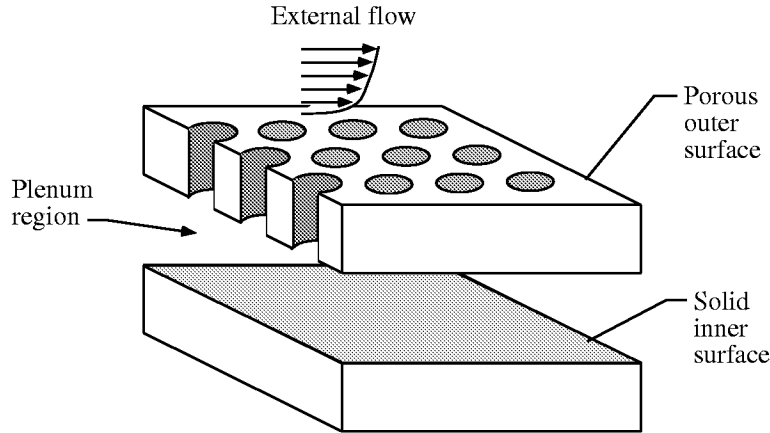

Figure 5.1. Schematic of basic passive porosity concept (from Hunter et al. 2001).

Passive porosity is designed to modify the surface pressure distribution. In its simplest form it consists of a porous skin over a cavity that has a solid back wall (see fig. 5.1). The cavity allows pressure communication among regions of pressure differences over the area covered by the porous surface. Typically the porous surface is a skin perforated with circular holes, although many variations of porous surfaces are possible.

Passive porous technology has been studied extensively both experimentally and computationally for many flow control applications. One representative application has been alleviation of shock/boundary layer interaction. For transonic flows over airfoils, it has been shown to reduce the strength of shocks and the amount of shock induced separation (Nagamatsu and Orozco 1984; Savu and Trifu 1984; Bahi and Ross 1983). Passive porosity has also been developed as a novel means of effecting aerodynamic body force and moment control (Wood et al. 1992). The loading asymmetry typically found on slender axisymmetric forebodies was successfully eliminated with passive porosity (Bauer and Hemsch 1992). This demonstrated the extension of porosity to three-dimensional flow fields.

Using similar technology, porosity has been applied to flight vehicles. A porous patch was added to the wing of the F/A-18E to solve a problem of uncontrolled roll discovered during initial flight tests (North 1998). Current research is investigating the development of design tools for complete aircraft configurations. The goal is to study the potential of replacement of conventional aerodynamic control effectors with passive porosity effectors in the design of a generic tailless fighter aircraft (Hunter et al. 2001). Passive porosity effector configurations were found to be competitive with conventional control approaches. An example of the ability of porosity to change forebody pressure distribution is shown in figure 5.2.

Passive porosity technology is proceeding to develop adaptive control techniques based on variation of porosity parameters via MEMS, smart memory alloys, or other smart skin. Alternatively, performance of the control system can also be affected by varying the plenum properties via similar means.

Simplified models for the effects of porosity have been developed and used in production CFD codes (Frink et al. 2001). However, the development of comprehensive models describing more parameters is necessary to fully exploit porosity in design of applications. Other applications that have been studied include separation control in cavity flows (Wilcox 1990) and drag reduction for ground vehicles, water vehicles, and ground structures.

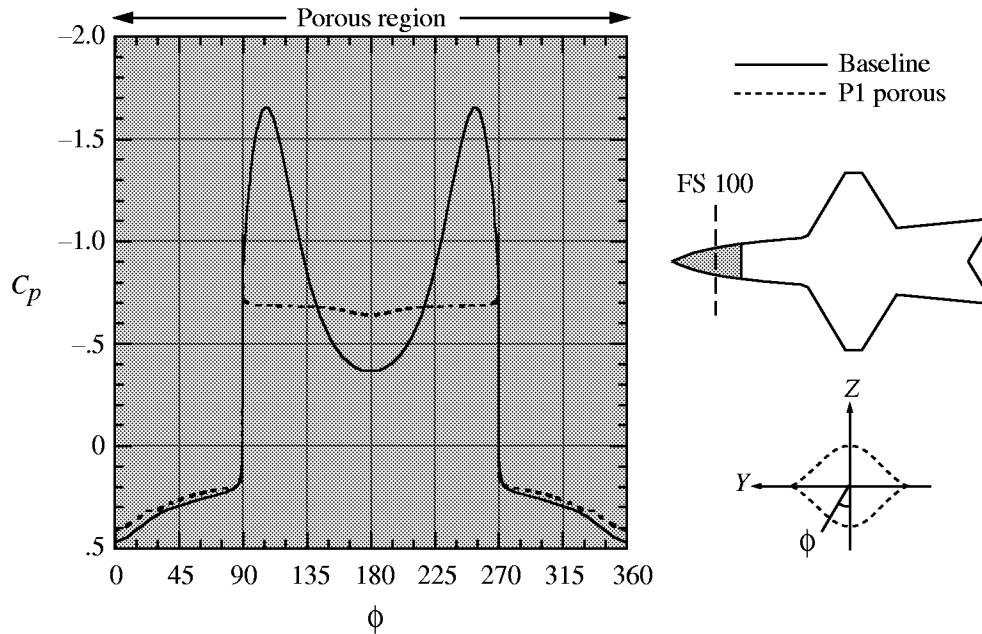

Figure 5.2. Comparison of forebody surface pressure coefficient between baseline and passive porous configuration (Hunter et al. 2001).

While passive porosity as described above has been developed for aerodynamic flow control for years, porous sheets are also a basic component of acoustic liners. The understanding of the interaction of sound and porous sheets and the ability to model and predict their behavior have been subjects of research in acoustic liners for decades. Lee (1993) and Brooks (1993) both proposed the use of porosity devices in the development of noise reduction methods for rotor blade vortex interaction noise. As discussed earlier, porosity is also a method that has been investigated in addressing flap side edge noise. Porosity represents one example of technology that crosses over between flow and noise control areas and, in the future, combining knowledge from the respective areas could probably produce greater advances in tools with which to apply porosity. It could also result in greater synergy in the application of porosity for both noise and flow control reasons simultaneously.

6. Concurrent Research Methods

Concurrent research methods are seen as a way to develop knowledge gained from research investigations into complex physical phenomena. In this section, two examples of such methods will be discussed from the point of view of their impacts on flow and noise control research. These methods are concurrent (or collaborative) experimental/computational techniques and concurrent (or multidisciplinary) computational methods. The advantage of the first method is that it provides an augmentation to what can be learned using an experimental or computational approach alone; the second method is a necessary development for designing and testing advanced concepts in flow and noise control.

6.1. Concurrent (Collaborative) Experimental/Computational Techniques

The synergy between computational and experimental techniques for investigating flow phenomena has been recognized for a number of years. In the field of aerodynamics, wind tunnel testing efficiently allows the evaluation of integrated forces and/or limited surface properties over a wide range of flow conditions. CFD simulations can provide insight into the fluid dynamics associated with those forces by

supplying a representation of the entire 3D flow field. Drawbacks of time accurate CFD techniques are that only limited flow conditions can be evaluated due to computational time required and that uncertainties exist in simulation accuracy due to gridding and turbulence modeling. Experimental limitations include uncertainties in the effect of model mounting, tunnel walls, and scale effects on measured values; difficulty in understanding unexpected results; and lead time required for model construction (the analogous limitation for current CFD methods is grid construction). In research of flow and noise control concepts, additional difficulties come from noise measurement capabilities (and background noise in tunnels) and the ability to construct, package, and control active flow control devices for wind tunnel models.

Collaboration between computational and experimental approaches to aerodynamic and aeroacoustic problems have clear value with specific applications of concurrent approaches illustrating this. CFD validation and wind tunnel diagnostics (or enhanced understanding) are primary examples, applicable even to basic aerodynamic investigations. At present, information resulting from wind tunnel tests is generally insufficient for validation of companion CFD simulations. Examples include Boeing 777 high speed testing in the National Transonic Facility (attempting to answer questions of wind tunnel-to-flight correlation), Hyper-X stage separation (where Arnold Engineering Development Center (AEDC) and Langley Research Center measured forces at Mach 6 do not match), and X-34 force differences between Unitary test sections 1 and 2. Research efforts on such unique vehicles or flow conditions should justify the regular application of advanced diagnostic techniques such as pressure sensitive paint (PSP), temperature sensitive paint, IR thermography, oil interferometry, and the pursuit of other techniques such as liquid crystal shear flow mapping. A critical example of this need is in high-lift flow transition, where during the AST Program, \$6 million was spent on the High Wing Transport model and test, gathering only limited data on transition location. The type of diagnostic information available from such concurrent experimental and numerical techniques might be a combined display of CFD and PSP data available in the wind tunnel control room within minutes of the data being acquired.

Such near real time display and extensive manipulation of data drive a requirement also generated by pure CFD work. This requirement is the generation of enormous data sets produced by three-dimensional, unsteady simulations that pose significant challenges for analyzing the output data in order to extract useful physical information such as flow events that lead to strong noise generation. Currently available post-processing tools are generally satisfactory for analyzing steady flow fields in both two or three spatial dimensions. However, there exists a strong need to develop more sophisticated methods for visualization and automated feature extraction from unsteady fields, particularly those of a stochastic nature. One of the potential avenues to interrogate such large databases involves the use of an immersion flow visualization environment that allows a researcher to gain a virtual reality perspective on specific features of interest such as prominent three-dimensional vortex structures. While this may appear futuristic, prototype environments of this nature are already being used for similar missions (Tufo et al. 1999). More pedestrian tools, such as the Unsteady Flow Analysis Tool Kit (UFAT) (Lane 1996), must also be employed on a routine basis to facilitate the best possible use of expensive numerical simulations. With comprehensive data analysis tools of this kind, it will be easier to gain the physical insights necessary when comparing numerical and experimental data or in developing effective flow and noise control strategies.

Computational techniques have often been used to guide placement of instrumentation for wind tunnel tests. In the flow and noise control areas, CFD input to placement of sensors and actuators will be critical. For example, Padula et al. (2000) applied multidisciplinary optimization tools including CFD to the design of a control system for a tailless fighter aircraft. The control effectors were limited to distributed shape change devices. A genetic algorithm was used to screen control effectors to reduce the number and

to satisfy control effectiveness criteria. Finally, the selected system was simulated and was able to stabilize and maneuver the aircraft without the use of conventional control surfaces.

6.2. Further Facility Issues

For noise control, identification of noise sources can be done experimentally using microphone measurements while determination of noise generation mechanisms is best done computationally. Indeed, for airframe noise, flow and acoustic measurements, steady CFD, and unsteady large-scale computations must all be used to identify relevant physics as well as to develop viable noise reduction devices. For any hitherto unknown broadband noise mechanism that represents the outcome of a complex chain of events (viz., the formation of turbulent flow structures, their interaction with solid surfaces to generate sound, and the scattering of sound by the surfaces before being radiated to the far field), a methodology of this type is not just desirable but essential. Substantial progress in noise control will require this type of concurrent computational/experimental research. It will also require entirely new experimental facilities.

To develop advanced jet engine inlet acoustic liner technology, industry relies frequently on NASA to test many liners in the NASA Langley Flow Impedance Facility. Its air flow capability should be increased to a Mach number of 0.8; new acoustic drivers will be needed to broaden its frequency range to 500 Hz to 10 kHz; and reliable, quiet, nonpolluting vacuum pumps will be needed in addition to a new boundary layer control system.

To continue airframe noise reduction research or other associated aeroacoustic testing, a new, larger Quiet Flow Facility is needed. The Quiet Flow Facility currently in use at NASA Langley Research Center has only a 2- by 3-foot nozzle surrounded by an anechoic chamber. This small test section size severely limits the model size that can be tested, thus putting into question data extrapolated to larger scale. The vision for this proposed new facility is an extremely versatile wind tunnel dedicated to aeroacoustic component research (i.e., flap or landing gear noise). It would be a nonreturn tunnel with a 6- by 9-foot test section with both open and closed test section capability. Tunnel speed would be adjustable from zero to a Mach number of 0.4. An anechoic chamber would surround the test section for taking far-field microphone data with a dedicated microphone array. Both the tunnel inlet and exit ducts would be acoustically treated to minimize both outside and internally generated noise from entering the test section area. The facility would be designed for low turbulence operation.

The U.S. aerospace community needs a new, large subsonic wind tunnel capable of measuring airframe noise in the next generation of advanced aircraft in order to meet long-term NASA goals. The problem is not one of measuring airframe noise on current aircraft. That can be done in either the Boeing Low Speed Aeroacoustic Facility (LSAF) or, for larger models, the NASA Ames 40- by 80-Foot Wind Tunnel. The German-Dutch DNW-LFF (Large Low-Speed Facility) has had this capability for the 20 years it has been in operation serving the European aerospace community. Although the NASA 14- by 22-Foot Subsonic Tunnel has been modified to add aeroacoustic capabilities, it is not as capable as the DNW Facility. The DNW test section area is 70 percent larger than the 14- by 22-Foot Tunnel and it is up to 20 dB quieter. Pushing down airframe noise levels by 10 to 20 dB however, will *not* be measurable above background noise levels in current NASA or Boeing facilities. Even with a DNW type facility, a 6- by 8-meter aeroacoustics wind tunnel, it will still be difficult to measure a 20-dB reduction in airframe noise using out-of-flow microphones. New technology such as out-of-flow microphone arrays will be necessary to measure these low noise levels.

These facilities and others in general will also have to be used differently. In the future, effective use of wind tunnel facilities will be different from today's emphasis on production testing. This emphasis

will be along the lines recommended by modern design of experiments (MDOE) concepts, including shorter duration tests with more tunnel entries. This usage pattern allows more efficient screening tests to identify critical parameters and find regions of interest, followed by more focused tests on specific flight regimes or configurations. It does, however, require a rapid model manufacturing capability along the line of Boeing's 7-day model manufacturing effort. Further enhancement of wind tunnel productivity can be obtained from CFD screening runs using MDOE for all wind tunnel tests; a policy to this effect would also force advances in CFD gridding and productivity to keep up with the workload associated with this task.

For external users, support of remote access to facilities would lower travel costs and improve scheduling flexibility. This capability has already been demonstrated in NASA tunnels, allowing researchers at Boeing to participate in wind tunnel tests via a collaborative engineering environment. Adoption of this approach would allow facility operation that is similar in style to that of the Hubble Space Telescope and ground-based telescopes.

6.3. Concurrent (Multidisciplinary) Computational Methods

Significant research has gone into defining and developing frameworks for multidisciplinary computational methods (Salas and Townsend 1998). Clearly, such methods are quite valuable in the design and optimization areas, allowing both a discovery of new optimal designs through the consideration of more than one discipline and a reduced design cycle time due to the ability to concurrently design more than one aspect of the product (i.e., the structural and aerodynamic design of a wing). In the research world, multidisciplinary computational tools will clearly be more of a necessity simply to understand the physics of newly emerging, intrinsically multidisciplinary advancements relevant to active flow and noise control. Both design and research needs for concurrent methods are important to NASA aeronautics goals.

6.3.1. Methods for Research

The investigation and development of new methods for flow control will require a thorough understanding of the physics inherent in various flow control devices or concepts such as porosity, microvortex generators, synthetic jets, and even flapping flight. Most of these concepts involve unsteady flow, and many further require a control system to achieve useful benefits in a practical application. Thus, basic behavior of a synthetic jet, for example, can be investigated with a time-accurate CFD code, but computational demonstration of active flow control will require the CFD to be coupled with numerical sensors and a control system with feedback. This has been done for simple problems (Allan et al. 1998) but is not yet usable for realistic flow control investigations. The design of certain types of devices such as those using flexible membranes—flapping flight with flexible wings, for example—will require coupling with structural analysis of appropriate materials.

Another future application of concurrent methods to research problems in flow control would involve simultaneous testing of candidate control algorithms for active flow control devices on computational and wind tunnel models. This will allow the computational model to demonstrate the physical phenomena responsible for specific model behavior found in the test without requiring the two models to accurately predict the same optimum performance. The physical understanding gained from the combined test can then be extrapolated to full scale or other configurations with much more confidence.

In noise control, high-order accurate Navier-Stokes CFD codes must be coupled with acoustic radiation codes in order to provide an analysis capability for the investigation of basic noise generation mechanisms on vehicles of interest. This capability is currently under development, and will allow various

candidate approaches for noise reduction to be evaluated before being incorporated into full-scale vehicles. One expects this development will be adequate for investigation of aerodynamic and propulsion-related noise prediction. With further refinement to include unsteady surface motion in the calculations, it would become possible to predict noise from rotating machinery problems such as ducted fans and advanced propellers (Farassat, private communication, 2000), as well as airframe noise sources such as flap side edges and landing gear. The coupling of noise prediction techniques for various components can yield additional benefits. For fan noise, for example, integrating various prediction elements (cascade aeroacoustics including noise generation and blade row transmission, duct propagation, and inlet radiation) would help eliminate ad hoc assumptions regarding the input to each individual stage, reveal potential ways of improving noise reduction (through precise definition of cause-and-effect relationships), and minimize the need for experimental tests.

Other areas of noise control, such as interior (cabin) noise or acoustic treatment of nacelles, require the addition of structural response and material properties disciplines. Active noise control techniques add similar requirements to active flow control, including control theory and modeling of sensors and actuators. In many of these applications, detailed simulation of fluid dynamics is not necessary. However, additional advances are needed in understanding material properties and in modeling requirements for structural response in important frequency ranges.

6.3.2. Methods for Design

Computational tools needed for design activities on future vehicles can be identified by looking at the disciplines associated with those vehicles. Optimization opportunities clearly come from those disciplines likely to have the most interaction, while design cycle benefits will come from maximizing concurrency between the various disciplines involved. Further, turning an analysis capability into a design tool will require the inclusion of some form of optimization capability in these proposed multidisciplinary codes. While global optimization of a system with multiple disciplines and constraints is difficult to imagine as a useful tool, a number of practical optimization tasks can easily be envisioned. The arrangement, strength, and orientation of an array of synthetic jets is one example; placement of sensors to detect flow separation is another. Noise control applications might include shaping of fan blade tips, optimizing sound insulation thickness, or material choice.

At this point, the computational requirements for such a system, including unsteady analysis, multiple disciplines, and optimization, are daunting. This suggests that design tools will need to use simplified models of certain aspects of the physics, and that future research should be directed into the validation and calibration of these models. A current example of this approach (with respect to flow control) is a recent effort in applying porosity to advanced fighter design. This project resulted in the development and validation of effective boundary conditions for porosity, and the incorporation of these boundary conditions into current production CFD codes (Frink et al. 2001). Another example is the recent investigation of control requirements and sensor placement as determined from a reduced order model of the Navier-Stokes equations (Allan 1999). A final example is the model developed by Bender, Anderson, and Yagle (1999) for simulating vane vortex generators that eliminated the need to define details of the vane geometry. The result was a reduction factor of three in the grid size over conventional methods of gridding vortex generators.

Since NASA aeronautics research encompasses a wide variety of physical problems and vehicle types, and since approaches to individual disciplines are still evolving, near-term research in multidisciplinary methods should continue to focus on establishing a framework for linking various disciplines and defining interface requirements for each discipline. While the multidisciplinary framework cannot guarantee

robustness of individual discipline codes, robustness and fault tolerance should be a trait of the framework. Demonstration of a multidisciplinary analysis capability for problems of interest should be a near-term (1 to 3 year) goal, while availability of a general purpose framework for linking codes is needed in 3 to 5 years.

6.4. Concurrent Methods Summary

Flow and noise control concepts can increasingly provide revolutionary new approaches to aerospace research and vehicle design in the 21st century. Concurrent experimental/computational methods and multidisciplinary computational methods will be critical new research tools for the investigation of new concepts since they aid in understanding the physical cause-and-effect relationships among the various disciplines involved. This is to emphasize that concurrent methods are essential to future research. New developments increasingly evolve when combining ideas from multidisciplinary backgrounds. This creativity can be enhanced by the ability to bring tools together. These methods will also provide NASA researchers and industry designers with more effective tools to devise and evaluate new concepts and approaches to flow and noise control. As constraints continue to increase (performance up, cost and space down, etc.) there will be more opportunity to create multifunction devices if concurrent methods are available.

7. Advanced Measurements

Over the next 10 years, the use of multidisciplinary approaches and revolutionary concepts in flow and noise control will demand the development of more global and/or nonintrusive measurement techniques. Global and nonintrusive measurement technologies in the context of flow and noise control are needed to: (1) provide insight into physical processes, (2) provide measurements for experimental research and development, (3) provide measurements for model and computer code validation, and (4) provide measurement feedback into the aircraft design process.

Global imaging of structure and spatial distribution of flow and noise features will take on increased importance in screening revolutionary concepts and validating computational models. Global measurements include both on- and off-body flow and noise visualization and diagnostics, as well as the mechanical deformations of the structures involved. Visualizing the flow and noise structure will provide insight into physical processes by observing features that are stationary or variable with time. This may include research and development with synthetic jets, blowing, integrated sensor/actuator/controller surfaces, designer materials for noise control, and other techniques where novel control approaches are used.

Off-body quantitative flow measurements of interest include pressure, density, density changes, temperature, and the velocity vector field. Quantitative on-body measurements of interest include pressure, temperature, strains and shear stresses (skin friction), deformations, flow direction, transition detection, model attitude, and forces and moments from balances.

Increased use of digital recording technology in lieu of analog methods has created more reliance on acquisition and processing software. As a result, the need for scientific programming resources over the next 10 years is expected to increase dramatically. In addition, the proliferation and use of these new digital devices will require a change in technical skills necessary to maintain and support such advanced measurement systems.

The need for dynamic global measurements at high data rates and large bandwidths will grow in conjunction with increasing technical requirements from the aerospace community for such technologies as

active flow and noise control. Work over the next 10 years should include efforts to reduce data acquisition and processing times as well as improve the response times, sensitivities, useful ranges, accuracies, and distribution of sensors employed. An example of this is developmental work on a field deployable acoustic measurement system surrounding airports. The FAA has recently expanded the radius of perceived noise levels that affect the physical and mental health of people up to a 10-mile radius around takeoff and landing zones. To adequately measure the noise radiation from aircraft, an array of sensors, sufficient to make global measurements with good resolution, must be distributed and synchronized within the 10-mile radius. The measurements will require high data rates (11 Mbps per channel) over large bandwidths (20 kHz) and real time displays. A prototype of this system will be available in 2 years and will provide data to assess reductions in noise levels from improvements in noise reduction designs and flight profiles of aircraft.

When possible, advanced measurement systems (Bell and Burner 1998) should (a) provide the right data in the right format, (b) be nonintrusive, (c) be operable by a nonspecialist, (d) be cost effective, (e) have sufficiently small uncertainty to meet test objectives, (f) not have a negative impact on productivity, and (g) accommodate other test techniques. Such advanced measurement systems need to be incorporated into the suite of available tools at our aerospace facilities as soon as is practical.

As an example, suppose there is a code validation measurement request to have synchronous, on- and off-body, global, nonintrusive, steady state, transient measurements such as pressure, temperature, velocity, and model deformations on and around flow control surfaces. To provide the right data in the right format, a fast responding temperature-insensitive pressure sensitive paint (PSP) that will accurately sense both the steady and unsteady surface pressures could be developed and applied to wind tunnel models. Embedded in the PSP could be video model deformation targets so that the global pressure measurements can be synchronously made with video model deformation (VMD) measurements. To obtain the global deformations, projection moiré interferometry (PMI) using an infrared projection grid would be coupled with the VMD measurements. Meanwhile, the flow would be seeded with temperature-sensitive particles that also serve as the seeding mechanism for a global flow diagnostic such as a combined Doppler global velocimetry (DGV)/particle image velocimetry (PIV). This arrangement has the potential to provide the right data in the right format, be nonintrusive, have sufficient uncertainty, not impact productivity, and be accommodating to other test techniques. Such unified systems need to transition from the laboratory to research applications. The costs associated with combining several measurement techniques may be balanced by reducing the number of tests required.

The advanced measurements wish list includes global skin friction measurements, global measurements for flight experiments, and higher data rates and bandwidth for dynamic measurements. Therefore, developmental work in techniques to measure skin friction (either directly or indirectly) should continue. Current calibration procedures are difficult to implement in industrial applications. Therefore, a mathematical model of the effects of mechanical shearing on optical properties is needed to provide an analytical form of calibration. Most of the optical measurement systems such as PIV, DGV, and especially the dynamic Rayleigh scattering technique, when deployed in 3D with temporal and spatial correlating capability, will require very high data rates and bandwidth capability. Similar to CFD and CAA post processing, these global measurement systems will require high level processing software written by expert programmers.

While much of the focus for this area is primarily on global measurement techniques, optical point measurements should be continued for specific applications. For example, in regions where it is difficult or impossible to inject particles for global seeded techniques such as PIV or DGV, development of a nonintrusive point technique such as laser induced thermal acoustics (LITA) must continue. Another area

where an optical point technique is needed is to replace hot wire measurements of unsteady flows. A technique such as Point Doppler Velocimetry (PDV) should be developed and compared with hot wire measurements to ascertain regions of validity.

8. Breakthrough Technologies

Microelectromechanical systems (MEMS) have experienced a phenomenal period of development over the last 10 to 15 years. Some MEMS devices are beginning to find mass application, notably the airbag-activation sensor for automobiles. The applications continue to expand at a very fast rate across many industries. A wide range of products are under development including rotational rate sensors and micro-optical switches for fiber optics. Increasingly, MEMS developers are able to construct complex moving microsystems and integrate these with microelectronics on single silicon chips (Scott 2000). These capabilities are expanding the possibilities for application.

In the aerospace field, MEMS potential has already been recognized in the sensor area both as another variety of nonintrusive instrumentation and as sensor capability for active flow control systems. Because shear stress is a fundamental quantity to aerodynamic performance, MEMS technology has been applied toward the development of a shear stress sensor for more than 10 years. Breuer (2000) describes new developments in thermal sensing type stress sensors. He also emphasizes that in the MEMS arena, manufacturing considerations and the design and performance demand much higher levels of integration.

In addition to sensor capability already briefly mentioned, other areas of growing MEMS application are of a more comprehensive or systems level. A significant example of this system level application is the microengine project that was initiated and funded by the Army Research Office in 1995 and later joined by the Defense Advanced Research Projects Agency (Dornheim 1999). One goal of this effort being carried out at MIT is to produce micropower generators. These microengines are on the order of a few millimeters in diameter and weigh about 1 gram. As a generator they produce 20 to 40 watts of power. An example of an assembled engine system and its components is shown in figure 8.1. The MIT effort is expanding the applications of this microengine technology to include microturbojet and micro-rockets (Epstein 2001). As propulsion devices, a few tenths of a Newton of thrust have been achieved thus far.

Between experience with initial applications and new tools and capabilities, the MEMS technology base is growing rapidly. This converging advance in MEMS technology together with physics-based prediction methods should allow the penetration of MEMS technology in aerospace applications to expand dramatically. Examples of possibilities range from active acoustic liners that could also reduce drag to integrated active controller systems for structural manipulation.

One additional application, and potentially very important, is to serve as a scaled-up laboratory for the coming nanotechnology. As much as it is common to experiment with scaled-down models of aircraft and components, MEMS may be used to experiment with the best application methodologies for nanotechnologies. This would ensure that nanotechnology could be deployed effectively and expertly in the aerospace arena as soon as the technology is available.

One important point to note, however, is that nanotechnology is not simply a scale down of micro-technology or MEMS-based systems. In contrast, nano is typically reserved for technologies that involve the control, manipulation, and exploitation of nanoscale materials, devices, and systems. It is for this reason that nanotechnologists tend to follow the example of nature in pursuing development of

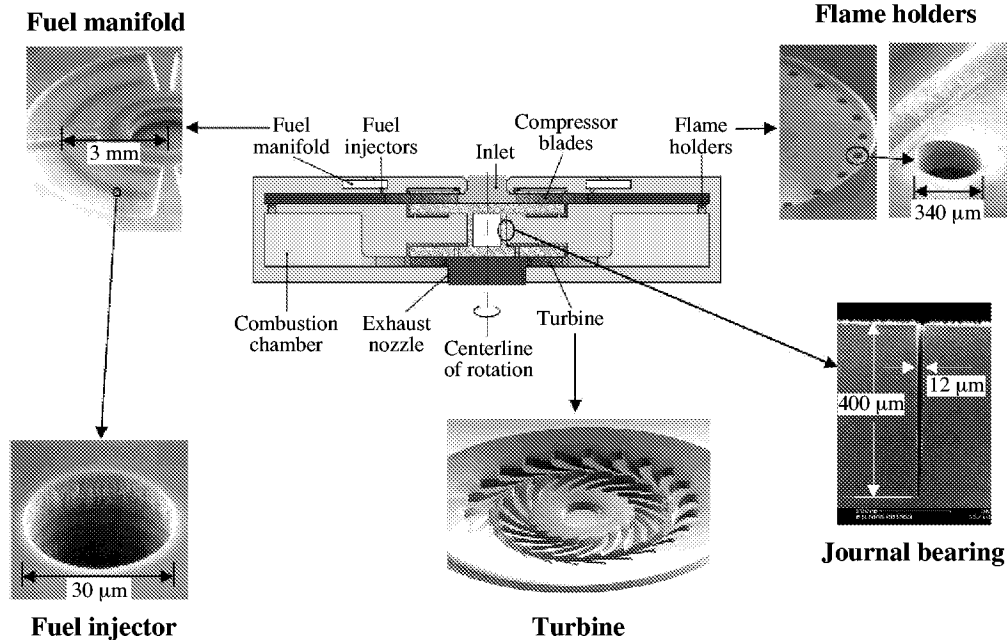

Figure 8.1. MIT microengine assembly and components (from Epstein 2001).

biologically inspired materials (i.e., skin), devices (ion pumps, synaptic channels), machines (i.e., cells, cell mitochondria), and systems concepts (i.e., flapping-wing flight, self-healing) that exist and thrive in these size and functionality domains.

Nanotechnology refers to the creation of materials, structures, and systems that are built at the scale of 1 to 100 nanometers (Meyyappan 2000). This is made possible through the precise manipulation of the positions of the constituent atomic particles and takes advantage of the phenomena and properties characteristic of that scale. It is anticipated that the dramatic breakthroughs of coming decades will be related to the development of nanotechnology. The U.S. Government has created the National Nanotechnology Initiative (www.nano.gov) with anticipated funding in 2001 of \$495 million. The effect of nanotechnology in material science developments is an example of the promise of nanotechnology. At the nanoscale, material can be manipulated leading to control of materials properties, faster chemical reactions, more efficient energy transfer, and the construction of devices that can interact with biological components at the cellular level (Nordwall 2000).

It may be important to note that the current embodiment of nanotechnology at NASA focuses on the exploitation and integration of single-wall carbon nanotubes (SWCNT). The technology that makes this possible is not directly related to conventional aerospace disciplines. However, what could be of value are the products made possible through use of this technology. These fall largely into two categories: machines and materials. The challenge is to conceive applications of this technology that can pay off in the aerospace domain.

In general, the most obvious impact of nanotechnology is the significant reduction in the weight of materials, devices, and systems that will be integrated into existing and new air- and space-vehicle platforms. Benefits from this nanotechnology, to name only a few, span the gamut of NASA objectives including lower cost and increased access to space, increasing the payload capacity of low-Earth orbit vehicles, enabling long-duration space flight, and most important, interplanetary exploration.

The nanomachine with the greatest potential and most often mentioned is the computer. The precise alignment of atomic particles in construction of a crystal lattice with embedded logic circuits will increase circuit densities and device speeds well beyond what is possible using today's methods. It will be possible to construct very powerful processing machines using nanotechnology. The payoff will be the enabling of interdisciplinary design.

It is also possible to construct classical mechanical devices at the atomic level. A common example is the shaft and bearing. It is not clear at this time how these subminiature devices would figure into Langley's aeromission. These devices could be used in control surfaces much like MEMS devices are used today, but nanotechnology is not limited to devices that can be built using photolithography. So it may be possible to conceive of nanotechnology machines that work beneath the wing's surface, impregnated into the skin, enabling a conformal wing design. Given the ability to construct a material with specific atomic structure and macroproperties, the problem immediately becomes one of defining properties that have the desired performance benefits. What kinds of material properties are required to produce improvements in flow and noise control? If nanomachines are integrated into designer materials, what might result is something that looks a lot like human skin where a flexible membrane has embedded in it tiny machines (pores) that perform a vital function (i.e., cooling).

Whether as a result of nanotechnology or other technologies, it is a safe assumption that computational power will increase dramatically just in the next decade. In addition, there is ongoing research aimed at advances in algorithms and pre- and post-processing methods that could lead to increases in efficiency of two orders of magnitude in computational throughput. Together, these advances point in a more immediate way to the possibility of computationally unconstrained multidisciplinary optimization. It would seem reasonable to undertake the construction of design algorithms and tools without regard to computational resources.

9. Recommendations

Many technically specific recommendations appear throughout this paper; however, the team recommends that research could be more productive toward future goals in flow and noise control research by ensuring that several obvious but very important general areas be strengthened. First, that research into fundamental flow and acoustics physics discovery, which is the seed corn of the entire research enterprise, be pursued vigorously and in an increasingly interdisciplinary, concurrent research method environment in order to produce solutions to more demanding, complex problems. In both flow and acoustics physics there is a particular need for the development of fully three-dimensional unsteady computational techniques.

Second, models and tools for fundamental flow and acoustic physics should be developed as part of the interdisciplinary, concurrent research methods. These concurrent methods should also enable research products having greater effectiveness and more multifunctional potential that could positively impact the deployment of research products. Recent research in flow control, and to some extent noise control, has emphasized the development of devices for application. However, the crucial element of developing the design capability required for such applications has been generally neglected. As a result, a necessary component of research efforts should be the focus on appropriately validated design tools applicable toward designing actuators, sensors, and implementation strategies.

Third, research endeavors should pursue novel actuator development for both flow and noise control strategies. Much of the recent effort in active flow control has involved low-speed flows. The outcome of this research will no doubt be beneficial in developing ways to control high-speed flows. However, as

pointed out by Walker (private communication 1999), certain inherently unique aspects of high-speed flows could pose new challenges for both control methodologies and hardware, in addition to the usual problems related to quantitative measurements in such flows. These issues include, but are not limited to, large variations in thermodynamic quantities including the presence of shocks, increased heat transfer near body surface, reduced turbulent transport, and relatively stable free shear flows. Consequently, actuators and sensors are required to operate in a relatively harsh environment, requiring high amplitude response at similarly higher frequencies. The existence of multiple significant degrees of freedom (which is more of a rule than an exception for high-speed flows) also adds to the complexity of the control algorithm. Given its unique combination of resources in terms of facilities and personnel, AAAC could potentially carve out a niche in the area of high-speed flow control.

Fourth, flow and noise control strategies and disciplines should be fully integrated into the initial design process, and that together with the above strategies should lead flow and noise control developments that enable new developments.

Fifth, create a comprehensive technical plan for design to flow and noise control goals. That is, devise a plan that would cover the fundamental research necessary to produce expertise that could be used to then create the comprehensive research and design tools envisioned. This plan would serve as the road map for the base program that would ensure the AAAC and the community at large were working in all areas required to achieve the aggressive enterprise goals.

Sixth, NASA's enterprise goal in noise reduction calls for a 20-dB reduction over a 20-year period; new facilities in aeroacoustics will be essential in obtaining this goal and should be added. New facilities will be necessary to provide the new capabilities that will in turn be required to research the technologies for these aggressive goals. There are three facilities, in particular, that are needed: a new Flow Impedance Tube, a new 6- by 9-Foot Quiet Flow Facility, and a new 6- by 8-Meter Low Speed Aeroacoustics Wind Tunnel. Each facility is needed to play a vital role in key noise reduction areas of liner technology, airframe noise, jet noise, and propulsion airframe integration.

Seventh, core competency capabilities must be updated by ensuring that core competencies include the leveraging of coming advances in breakthrough technologies, for example in MEMS and nanotechnology, and concurrent research methods.

Eighth, maintain and add as necessary small, low cost proof-of-concept wind tunnels and laboratories where high-risk research can be started without the lengthy budgeting and scheduling of larger facilities. This will be one key tool necessary to facilitate the innovative research that is so needed.

10. Concluding Remarks

This paper has outlined just a few of the many possible directions and technologies that can, if pursued to the fullest, revolutionize the aerospace industry, its products, and its impact on the public it serves. With a forward thinking, proactive aerospace industry, including the NASA labs that have been so instrumental in past development of flight, there is a world of opportunity yet to be explored. This paper began with a vision of what the aerospace transport system should look like to respond to the demands and trends of the public being served. Then the critical technologies of flow and noise control were reviewed with emphasis on future directions. The idea of synergy between flow and noise control technologies was discussed as a necessary development that will need to accelerate if the industry will be able to provide technical solutions to meet the demand for the 2020 time frame.

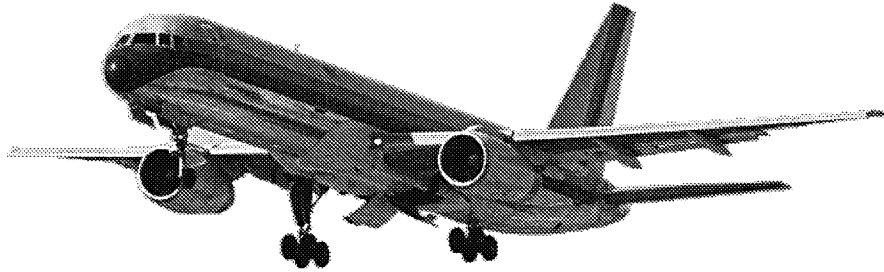

Figure 10.1. NASA Langley Boeing 757 aircraft.

There is little question that modern commercial transport aircraft (fig. 10.1) are a technical marvel of recent decades and create a viable, widespread air transport system. Over what is now almost exactly one century, current aircraft have reached a very high level of performance and reliability by almost any standard.

As outlined throughout this paper, however, future requirements will be demanding and are likely to mandate a rethinking of the best aircraft platform for new flow and noise control technologies, not to mention other technologies vital to overall success of commercial transports. This represents another future direction with great potential for impacting not only the way aircraft look 20 years from now, but also their capabilities toward the aggressive goals that will be needed. This future direction entails the system level design of aircraft and specifically the integration of propulsion and airframe for configurations that are unconstrained by the current, prevalent configuration.

A recent study from NASA Langley has reviewed many promising concepts for dramatic propulsion airframe integration that can have significant performance and noise goal gains (Yaros et al. 1998). The blended forward swept body (fig. 10.2) and the twin fuselage (fig. 10.3) concepts illustrate just two radical aircraft platforms that represent both many challenges toward exceeding the capabilities of modern aircraft and also many opportunities to create significant rather than incremental gains. A reshaping of the way aircraft are made using the synergistic airframe-propulsion interactions and integrations ideas described by Yaros et al. (1998) are a critical area needing combination with new flow and noise technology in order to provide technology solutions for the public air transport system in twenty years.

If those future directions described above are pursued aggressively, with 20 years of development aerospace vehicles of the 2020 time frame will be radically different and much more capable. To illustrate, here is one possibility: a fictional description of the rollout of a new commercial airliner in the year 2020.

The premier American developer and manufacturer of commercial aircraft rolled out its new model, the M2020, this week. Just one look at the M2020 tells you that this isn't just another airplane. Most notably absent is the vertical tail and elevator assembly that has been a familiar attribute of all transport aircraft to date. In its place are two rear mounted engines more reminiscent of the Douglas DC-9 series than more recent Boeing models. The engines are ultra high bypass ducted fans, or ducted fan propulsor (DFP). Unducted fans were developed and tested in the late 1980s as they promised increased efficiency over the standard turbofan jet engine but were abandoned due, in part, to their loud propeller noise. The fan noise on the M2020 has been greatly reduced by a shroud that incorporates not only noise control systems, but also flow control and thrust vectoring systems, providing the control authority previously achieved with the vertical tail and elevators. The total system, propulsion plus flight control, has about

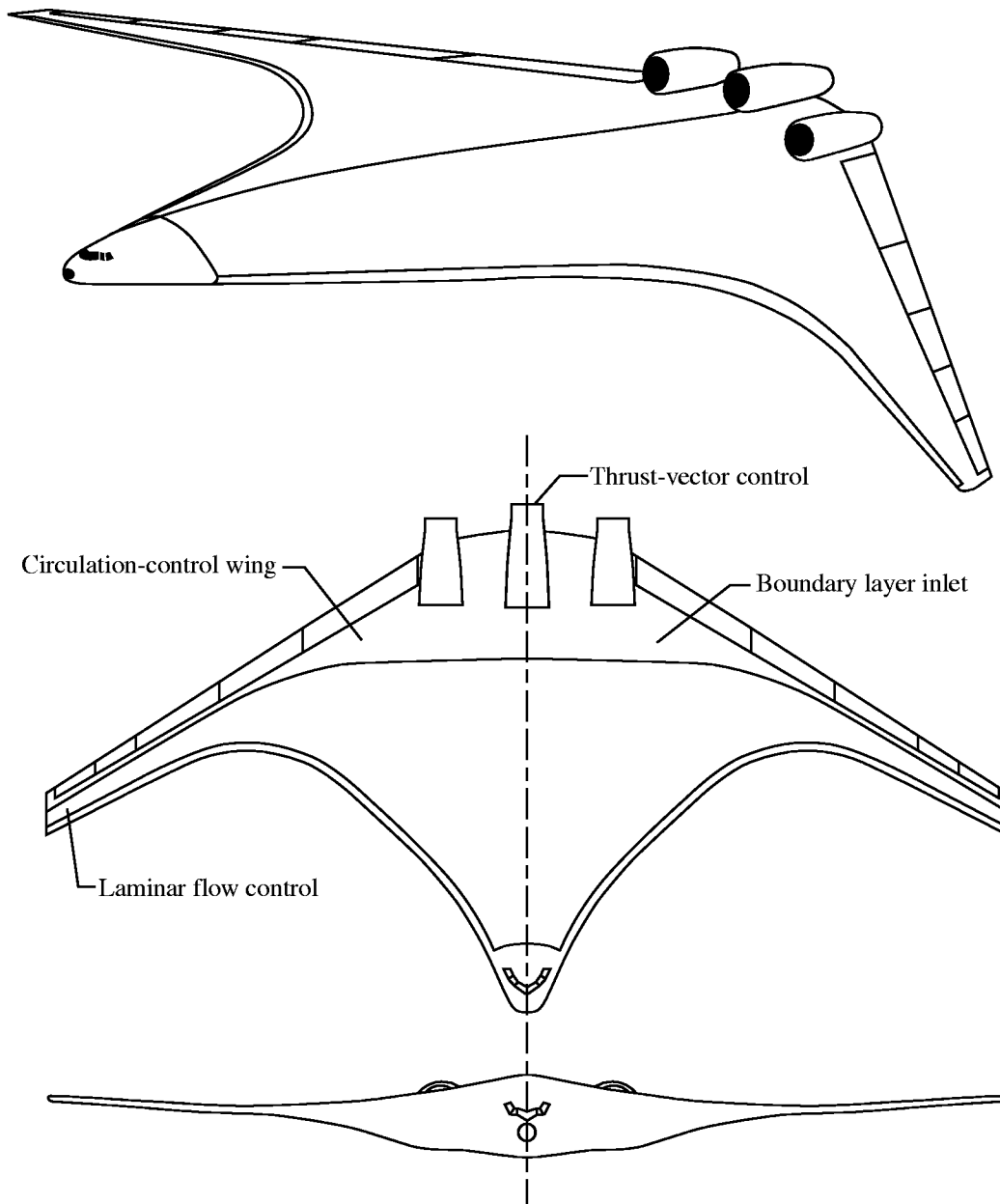

Figure 10.2. Blended forward swept body aircraft concept (from Yaros et al. 1998).

20 percent less drag and 25 percent less weight than engines and rear tail assemblies of the comparable Boeing 777.

With the tail mounted engine and shroud assembly providing all the aircraft's thrust and most of its control forces, wing design is optimized to provide lift. Immediately apparent is the wing slimness, appearing almost fragile. Closer inspection reveals that all evidence of classic control surfaces is absent. The wing is a conformal design with the ability to adapt its shape to the flight regime in which the aircraft is operating. This is made possible by a tough, flexible polymer skin that overlays a substructure of active composite material. The wing adapts to provide the required lift profiles at takeoff, cruise, and landing while delivering 5 percent less drag at cruise than classic designs. The wing weighs about 50 percent less than classic designs.

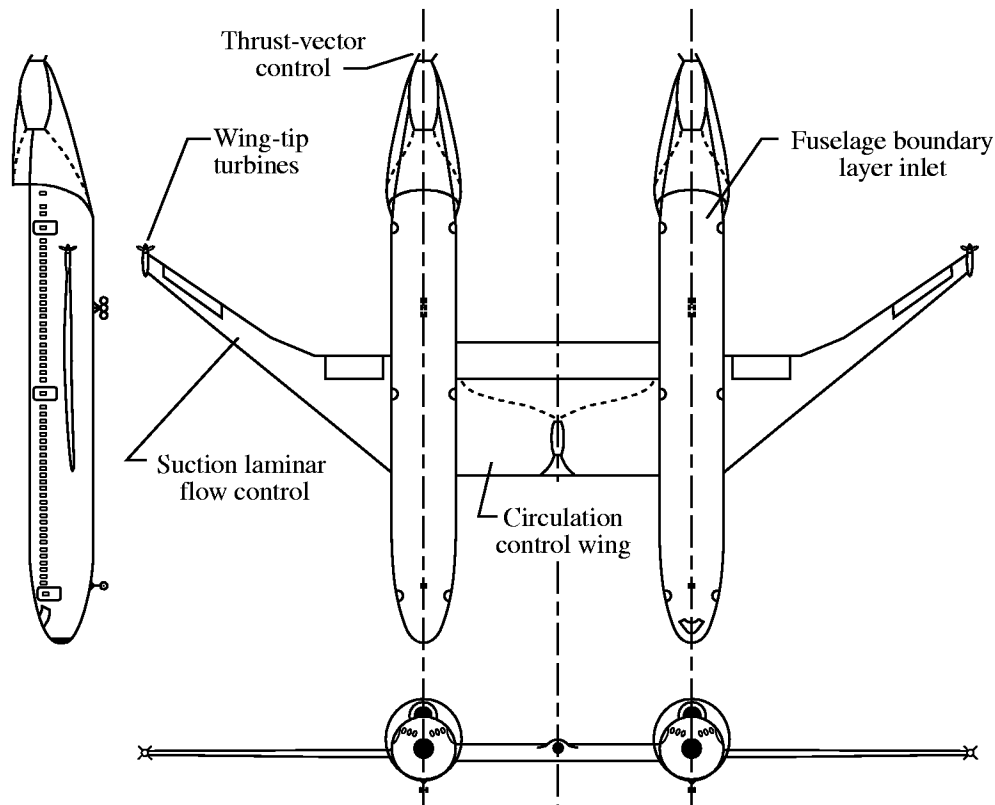

Figure 10.3. Twin fuselage aircraft concept (from Yaros et al. 1998).

Continuing up to the nose of the aircraft, we notice that the familiar cockpit shape is gone. The glass windshield has been replaced by the glass cockpit. In the M2020, the refinement of the glass cockpit has been taken to its logical end with external, all weather sensors delivering to the cockpit displays a better view of the aircraft's immediate area than ever possible through a windshield. Relieved of the necessity to integrate a windshield into the nose, designers have optimized the shape of the forward section of the aircraft to reduce drag another 5 percent.

Here again, closer inspection shows more than first meets the eye. Subminiature flow control devices are integrated into the forward section of the fuselage. These devices not only stabilize the flow to reduce drag, but also deliver control forces to the fuselage, in effect steering the nose. Steering the nose of the aircraft has been shown to relieve stress in the fuselage, allowing a further weight reduction in the already lightweight composite structure. The M2020 fuselage has lost 25 percent of the weight of the comparable 777 airliner.

Maybe the most significant feature of the M2020 is one that is not visible at all, but makes all the previous technology possible. The M2020 has as its nervous system a vehicle management system that pervades every square inch of the aircraft, sensing and controlling the hybrid technologies, acting as the glue that, quite literally, holds the aircraft together. The M2020 design represents a milestone in digital systems in that digital design technology has matured to the point that it could be integrated with the more classic mechanical design methodologies in the Catia CAD/CAM package. Designers are free to incorporate digital systems with a confidence never before possible, making extraordinary advances possible.

Of course, being around just one takeoff of the M2020 proves that this aircraft represents a whole new class of low noise aircraft by the faint rumble and whine that you hear from the M2020's takeoff roll. Advances in noise reduction research and deployment have proven to be a key enabler for the growth of air traffic. Noise reduction has been essential in providing for low community impact as air traffic has increased almost 250 percent since the turn of the century, and especially with the increase in the number and usage of smaller, local airports.

The M2020 noise signature reflects the product of sustained and comprehensive noise reduction research going back to the Advanced Subsonic Transport program of the 1990s. The M2020 has incorporated advancements in virtually all areas of noise research beginning with unique shaping of the fuselage and integration of the ducted fan propulsors above and aft of the fuselage. Inside the engine there is an array of components that have active and passive noise reduction mechanisms, including adaptive duct linings that not only reduce noise radiation, but also filter the spectral content so that radiated noise is less annoying from both amplitude and frequency components. Through other revolutionary developments, the airframe noise floor of the M2020 has been lowered by the flexible wing that doesn't have separate flap elements. It does have microdevices on the leading and trailing edges of the wing similar to owl physiology. Other noise reduction technology has been highly integrated throughout the aircraft.

As the M2020 rolls out and we marvel at its technological achievement, we are struck by the contradictions of how logical this next step in aeronautical design is, and at the same time how revolutionary. What is really exciting is that even as revolutionary as the M2020 is, it is just the first of a new class of aircraft that will look radically different from the traditional configurations and will provide revolutionary performance for the public.

11. References

- Airbus Industries 1999: *Airbus Global Market Forecast*. <http://www.airbus.com> Accessed Jan. 23, 2002.
- Allan, B. G. 1999: Optimal Control Using a Reduced Order Model of the Incompressible Navier-Stokes Equations. *Proceedings of the 3rd ASME/JSME Joint Fluids Engineering Conference*, FEDSM99-6927.
- Allan, B. G.; Packard, A.; and Holt, M. 1998: Simulation of a Controlled Airfoil With Jets. *J. Guid., Control, & Dyn.*, vol. 21, no. 2, pp. 257–263.
- Anders, J. B.; Walsh, M. J.; and Bushnell, D. M. 1988: The Fix for Tough Spots. *Aerosp. America*, vol. 26, p. 14.
- Anders, J. B.; and Watson, R. D. 1985: Airfoil Large-Eddy Breakup Devices for Turbulent Drag Reduction. AIAA-85-0520.
- Anders, S. G.; and Fischer, M. C. 1999: *F-16XL-2 Supersonic Laminar Flow Control Flight Test Experiment*. NASA/TP-1999-209683.
- Anderson, B. A.; Wagnanski, I. J.; and Gutmark, E. J. 1999: Noise Reduction by Interaction of Flexible Filaments With an Underexpanded Supersonic Jet. AIAA-99-0080.
- Anderson, B. H.; and Gibb, J. 1996: Vortex Generator Installation Studies on Steady State and Dynamic Distortion. AIAA-96-3279.
- Anderson, B. H.; Miller, D. N.; Yagle, P. J.; and Truax, P. P. 1999: A Study of MEMS Flow Control for the Management of Engine Face Distortion in Compact Inlet Systems. *Proceedings of the 3rd ASME/JSME Joint Fluids Engineering Conference*, FEDSM99-9627.
- Anderson, B. T.; and Bohn-Meyer, M. 1992: *Overview of Supersonic Laminar Flow Control Research on the F-16XL Ships 1 and 2*. SAE Paper 921994.
- Anon. 1985: *Aerospace Facts & Figures 1985–86*: Aerosp. Ind. Assoc. America, Inc., pp. 94–95.
- Anon. 1995: *Aerospace Facts & Figures 1995–96*: Aerosp. Ind. Assoc. America, Inc., pp. 92–93.
- Anon. 2000: Extensive Supersonic Laminar Flow Attained Passively in Flight. News Release No. 00-13, NASA Dryden Flight Research Center.
- Anon. 2000: *2000 Current Market Outlook*. Boeing Commercial Airplane Co.
- Antonatos, P. P. 1966: Laminar Flow Control-Concept and Applications. *Astronaut. & Aeronaut.*, vol. 4, no. 7, pp. 32–36.
- Arcara, P. C., Jr.; Bartlett, D. W.; and McCullers, L. A. 1991: *Analysis for the Application of Hybrid Laminar Flow Control to a Long-Range Subsonic Transport Aircraft*. SAE Paper 912113.
- Bacher, E. V.; and Smith, C. R. 1985: A Combined Visualization-Anemometry Study of the Turbulent Drag Reducing Mechanisms of Triangular Micro-Groove Surface Modifications. AIAA-85-0548.
- Bahi, L.; Ross, J. M.; and Nagamatsu, H. T. 1983: Passive Shock Wave/Boundary Layer Control for Transonic Airfoil Drag Reduction. AIAA-83-0137.

- Barrett, R.; and Farokhi, S. 1993: On the Aerodynamics and Performance of Active Vortex Generators. AIAA-93-3447-CP.
- Bauer, S. X. S.; and Hensch, M. J. 1992: Alleviation of Side Force on Tangent-Ogive Forebodies Using Passive Porosity. AIAA-92-2711.
- Bell, J. H.; and Burner, A. W. 1998: Data Fusion in Wind Tunnel Testing; Combined Pressure Paint and Model Deformation Measurements (Invited). AIAA-98-2500.
- Bender, E. E.; Anderson, B. H.; and Yagle, P. J. 1999: Vortex Generator Modeling for Navier-Stokes Codes. *Third ASME/JSME Joint Fluids Engineering Conference*, FEDSM99-6919.
- Benjamin, T. B. 1960: Effects of a Flexible Boundary on Hydro-Dynamic Stability. *J. Fluid Mech.*, vol. 9, pp. 513–532.
- Benjamin, T. B. 1963: The Three Fold Classification of Unstable Disturbances in Flexible Surfaces Bounding Inviscid Flows. *J. Fluid Mech.*, vol. 16, pp. 436–450.
- Benjamin, T. B. 1966: Fluid Flow With Flexible Boundaries. *Applied Mechanics*, H. Gorlter and P. Sorger, eds., Springer-Verlag, pp. 109–128.
- Berchert, D. W.; Bruse, M.; and Hage, W. 2000: Experiments With Three-Dimensional Riblets as an Idealized Model of Shark Skin. *Exp. Fluids*, vol. 28, no. 5, pp. 403–412.
- Bertelrud, A. 1986: Manipulated Turbulence Structure in Flight. *Proceedings of the First European Turbulence Conference: Advances in Turbulence*, G. Comte-Bellot and J. Mathieu, eds., Springer-Verlag, pp. 524–532.
- Bevan, J. S. 1998: *Analysis and Testing of Plates With Piezoelectric Sensors and Actuators*. NASA/CR-1998-207667.
- Blackwelder, R. F.; and Chang, S.-I. 1986: Length Scales and Correlations in a LEBU Modified Turbulent Boundary Layer. AIAA-86-0287.
- Bogdevich, V. G.; Maltsev, L. I.; and Maluga, A. G. 1998: Optimization of Distributed Gas Injection Into a Turbulent Boundary Layer for Drag Reduction. *Proceedings of the International Symposium on Seawater Drag Reduction*, Office of Naval Research, pp. 327–330.
- Bond, D. 2001: The Book on Noise Reaches Chapter 4. *Aviation Week & Space Technol.*, vol. 154, no. 1, pp. 48–53.
- Bowers, A. H.; and Pahle, J. W. 1996: *Thrust Vectoring on the NASA F-18 High Alpha Research Vehicle*. NASA TM-4771.
- Brandon, J. M.; Simon, J. M.; Owens, D. B.; and Kiddy, J. S. 1996: Free-Flight Investigation of Forebody Blowing for Stability and Control. AIAA-96-3444.
- Breuer, K. 2000: MEMS Sensors for Aerodynamic Applications—the Good, the Bad (and the Ugly). AIAA-2000-0251.
- Brookfield, J. M.; and Waitz, I. A. 2000: Trailing Edge Blowing for Reduction of Turbomachinery Fan Noise. *AIAA J. Propulsion & Power*, vol. 16, no. 1, pp. 57–64.
- Brooks, T. F. 1993: Studies of Blade-Vortex Interaction Noise Reduction by Rotor Blade Modification. NOISE-CON 93, H. Hubbard, ed., Noise Control Foundation, pp. 57–66.

- Brooks, T. F.; Pope, D. S.; and Marcolini, M. A. 1989: *Airfoil Self Noise and Prediction*. NASA RP-1218.
- Bryant, R. G.; Fox, R. L.; Lachowicz, J. T.; and Chen, F.-J. 1999: Piezoelectric Synthetic Jets for Aircraft Control Surfaces. *Smart Structures and Materials: Industrial and Commercial Applications of Smart Structural Technology, 6th Annual International Symposium*. SPIE, pp. 220–228.
- Burr, R. F.; Berger, S. S.; and Tence, D. A. 1996: Overview of Phase Change Piezoelectric Ink Jet Fluids Modeling and Design. ASME FED-Vol. 239, pp. 545–552.
- Bushnell, D. M. 1984: NASA Research on Viscous Drag Reduction II. *Laminar-Turbulent Boundary Layers*, Vol. 11, E. M. Uram and H. E. Weber, eds., ASME, pp. 93–98.
- Bushnell, D. M. 1990: Supersonic Aircraft Drag Reduction. AIAA-90-1596.
- Bushnell, D. M. 1997: Application Frontiers of “Designer Fluid Mechanics” — Visions Versus Reality or an Attempt to Answer the Perennial Question “Why Isn’t It Used?” AIAA-97-2110.
- Bushnell, D. M.; Hefner, J. N.; and Ash, R. L. 1977: Effect of Compliant Wall Motion on Turbulent Boundary Layers. *Phys. Fluids*, vol. 20, no. 10, pp. S31–S58.
- Bushnell, D. M.; and Tuttle, M. H. 1979: *Survey and Bibliography on Attainment of Laminar Flow Control in Air Using Pressure Gradient and Suction*. NASA RP-1035, Vol. 1.
- Calarese, W.; Crisler, W. P.; and Gustafson, G. L. 1985: Afterbody Drag Reduction by Vortex Generators. AIAA-85-0354.
- Carpenter, P. W. 1990: Status of Transition Delay Using Compliant Walls. *Viscous Drag Reduction in Boundary Layers*, Vol. 123, D. M. Bushnell and J. N. Hefner, eds., AIAA, pp. 79–113.
- Carpenter, P. W. 1993: Optimization of Multiple-Panel Compliant Walls for Delay of Laminar-Turbulent Transition. *AIAA J.*, vol. 31, no. 7, pp. 1187–1188.
- Carpenter, P. W.; and Garrad, A. D. 1985: The Hydrodynamic Stability of Flow Over Kramer-Type Compliant Surfaces: Part 1. Tollmien-Schlichting Instabilities. *J. Fluid Mech.*, vol. 155, pp. 465–510.
- Carpenter, P. W.; and Garrad, A. D. 1986: The Hydrodynamic Stability of Flow Over Kramer-Type Compliant Surfaces: Part 2. Flow-Induced Surface Instabilities. *J. Fluid Mech.*, vol. 170, pp. 199–232.
- Carpenter, P. W.; and Morris, P. J. 1989: Growth of 3-D Instabilities in Flow Over Compliant Walls. Presented at *Fourth Asian Congress of Fluid Mechanics* (Hong Kong).
- Cataldi, P.; Ahuja, K. K.; and Gaeta, R. J. 1999: Enhanced Sound Absorption Through Negative Bias Flow. AIAA-99-1879.
- Cattafesta, L.; Mathew, J.; Wang, W.; and Kurdila, A. 2000: *Modeling of Piezoelectric Actuators for Fluid Flow Control*. SAE Paper 2000-01-5534.
- Choi, H.; Moin, P.; and Kim, J. 1994: Active Turbulence Control for Drag Reduction in Wall-Bounded Flows. *J. Fluid Mech.*, vol. 262, pp. 75–110.
- Choi, K.-S.; and Clayton, B. R. 1998: The Mechanism of Turbulent Drag Reduction With Wall Oscillation. *Proceedings of the International Symposium on Seawater Drag Reduction*, Office of Naval Research, pp. 229–236.

- Cole, J. N.; England, R. T.; and Power, R. G. 1960: *Effects of Various Exhaust Blast Deflectors on the Acoustic Noise Characteristics of 1000-Pound Thrust Rockets*. WADD TR 60-6, U.S. Air Force. (Also available from DDC as AD 251 833.)
- Coleman, W. S. 1961: Roughness Due to Insects. *Boundary Layer and Flow Control*, Vol. 2, G. V. Lachmann, ed., Pergamon Press, pp. 682–747.
- Collier, F. S., Jr. 1993: An Overview of Recent Subsonic Laminar Flow Control Flight Experiments. AIAA-93-2987.
- Condit, P. 1996: Performance, Process, and Value: Commercial Aircraft Design in the 21st Century. *Wright Brothers Lectureship in Aeronautics, World Aviation Congress and Exposition*, SAE/AIAA.
- Crane, S. P.; Cunefare, K. A.; Engelstad, S. P.; and Powell, E. A. 1997: A Comparison of Design Optimization Formulations for Minimization of Noise Transmission in a Cylinder. *J. Aircr.*, vol. 34, no. 2, pp. 236–243.
- Crighton, D. G. 1991: Airframe Noise. *Aeroacoustics of Flight Vehicles: Theory and Practice, Vol. 1: Noise Sources*, H. Hubbard, ed., NASA RP-1258, pp. 391–447.
- Davy, R.; and Remy, H. 1998: Airframe Noise Characteristics on a 1/11 Scale Airbus Model. AIAA-98-2335.
- Dean, P. D. 1976: On the In-Situ Control of Acoustic Liner Attenuation. ASME Paper No. 76-GT-61.
- DeMeis, R. 1988: Stick-to-it Riblets. *Aerosp. America*, vol. 26, pp. 48–49.
- Dhanak, M. R.; and Si, C. 1998: On the Physics of Skin Friction Reduction Through Wall Oscillation. *Proceedings of the International Symposium on Seawater Drag Reduction*, Office of Naval Research, pp. 237–239.
- Dobrzynski, W.; and Buchholz, H. 1997: Full-Scale Noise Testing on Airbus Landing Gears in the German Dutch Wind Tunnel. AIAA-97-1597.
- Dobrzynski, W.; Chow, L. C.; Guion, P.; and Shiells, D. 2000: A European Study on Landing Gear Airframe Noise Sources. AIAA-2000-1971.
- Dornheim, M. A. 1999: Turbojet on a Chip To Run in 2000. *Aviation Week & Space Technol.*, vol. 151, no. 2, pp. 50–52.
- Dougherty, R. P. 1996: Nacelle Acoustic Design by Ray Tracing in Three Dimensions. AIAA-96-1773.
- Dougherty, R. P. 1999: A Parabolic Approximation for Flow Effects on Sound Propagation in Nonuniform, Softwall Ducts. AIAA-99-1822.
- Duncan, J. H. 1986: The Response of an Incompressible, Viscoelastic Coating to Pressure Fluctuations in a Turbulent Boundary Layer. *J. Fluid Mech.*, vol. 171, pp. 339–363.
- Dunn, D. W.; and Lin, C. C. 1953: On the Role of Three-Dimensional Disturbances in the Stability of Supersonic Boundary Layers. *J. Aeronaut. Sci.*, vol. 20, pp. 577–578.
- Elliott, S. J. 1999: Down With Noise. *IEEE Spectr.*, vol. 36, no. 6, pp. 54–61.
- Englar, R. J.; and Applegate, C. A. 1984: *Circulation Control—A Bibliography of DTNSRDC Research and Selected Outside References*. DTNSRDC Report 84-052.
- Envia, E. 2001: Fan Noise Reduction: An Overview. AIAA-2001-0661.

- Epstein, A. H. 2001: *MIT MicroEngine Project: Shirt-Button Sized Jet Engines, Generators, and Rocket Engines*. NASA Langley Colloquium Lecture.
- Ericsson, L. E.; and Beyers, M. E. 1999: Effect of Nose Slenderness on Forebody Flow Control. *J. Aircr.*, vol. 36, no. 5, pp. 885–889.
- Federal Aviation Administration 1974: *Noise Standards: Aircraft Type and Airworthiness Certification*. FAR Pt. 36. (Consolidated reprint Aug. 12, 1985.)
- Federal Aviation Administration 2001: FAA Aerospace Forecasts Fiscal Years 2000–2011 dated March 2000. <http://www.faa.gov> Accessed Jan. 23, 2002.
- Fein, J. A. 1998: Dolphin Drag Reduction: Myth or Magic. *Proceedings of the International Symposium on Seawater Drag Reduction*, Office of Naval Research, pp. 429–432.
- Fiedler, H. E.; and Fernholz, H. -H. 1990: On Management and Control of Turbulent Boundary Layers. *Progress in Aerospace Sciences*, Vol. 27, Pergamon Press, pp. 305–387.
- Follet, J. I.; Betts, J. F.; and Kelly, J. J. 2001: Improvements to Acoustic Liner Broadband Absorption Using Bias Flow. AIAA-2001-0823.
- Freund, J., Lele, S. K., and Moin, P. 2000: Numerical Simulation of a Mach 1.92 Turbulent Jet and Its Sound Field. *AIAA J.*, vol. 38, no. 11, pp. 2023–2031.
- Frink, N. T.; Bonhaus, D.; Vasta, V.; Bauer, S.; and Tinetti, A. 2001: A Boundary Condition for Simulation of Flow Over Porous Surfaces. AIAA-2001-2412.
- Fuller, C. R.; Johnson, M. E.; and Griffin, J. 2000: Active-Passive Control of Aircraft Interior Boundary Layer Noise Using Smart Foam. AIAA-2000-2041.
- Gad-el-Hak, M. 1986: Boundary Layer Interactions With Compliant Coatings: An Overview. *Appl. Mech. Rev.*, vol. 39, no. 4, pp. 511–523.
- Gad-el-Hak, M. 1987: Compliant Coatings Research: A Guide to the Experimentalist. *J. Fluids & Struc.*, vol. 1, no. 1, pp. 55–70.
- Gad-el-Hak, M. 1996: Compliant Coatings: A Decade of Progress. *Appl. Mech. Rev.*, vol. 49, no. 10, part 2, pp. S147–S157.
- Gad-el-Hak, M. 1998: Compliant Coatings: The Simpler Alternative. *Proceedings of the International Symposium on Seawater Drag Reduction*, Office of Naval Research, pp. 197–204.
- Gad-el-Hak, M.; Pollard, A.; and Bonnet, J.-P.; eds. 1998: *Flow Control: Fundamentals and Practices*. Springer-Verlag.
- Gallagher, J. A.; and Thomas, A. S. W. 1984: Turbulent Boundary Layer Characteristics Over Streamwise Grooves. AIAA-84-2185.
- Ganz, U. W.; Joppa, P. D.; Patten, T. J.; and Scharpf, D. F. 1998: *Boeing 18-Inch Fan Rig Broadband Noise Test*. NASA/CR-1998-208704.
- Gasljevic, K.; and Matthys, E. F. 1996: Field Test of a Drag-Reducing Surfactant Additive in a Hydronic Cooling System. ASME FED-Vol. 237, pp. 249–260.

- Gaster, M. 1988: Is the Dolphin a Red-Herring? *Turbulence Management and Relaminarisation*. H. W. Liepmann and R. Narasimha, eds., Springer-Verlag, pp. 285–304.
- Gély, D.; Elias, G.; Bresson, C.; Foulon, H.; and Radulovic, S. 2000: Reduction of Supersonic Jet Noise, Application to the Ariane 5 Launch Vehicle. AIAA-2000-2026.
- Gibbs, G. P.; Eure, K. W.; and Lloyd, J. W. 1999: Active Control of Turbulent Boundary Layer Induced Sound Radiation From Aircraft Style Panels. *Proceedings of Active 99*, Inst. Noise Control Eng.
- Gilyard, G. B.; and Bolonkin, A. 2000: *Optimal Pitch Thrust-Vector Angle and Benefits for All Flight Regimes*. NASA/TM-2000-209021.
- Glegg, S. A. L.; and Devenport, W. J. 2000: Compact Eddy Structures and Their Application to Aeroacoustics. AIAA-2000-1995.
- Glegg, S. A. L.; and Jochault, C. 1997: Broadband Self Noise From a Ducted Fan. AIAA-97-1612.
- Glick, P. A. 1939: *The Distribution of Insects, Spiders, and Mites in the Air*. Tech. Bull. No. 673, U.S. Dep. Agriculture.
- Gliebe, P. R. 1996: Fan Broadband Noise—The Floor to High Bypass Engine Noise Reduction. *Proceedings of the Fourteenth National Conference on Noise Control Engineering*, Part 1, Noise Control Foundation, pp. 133–138.
- Gliebe, P. R.; Brausch, J. F.; Majjigi, R. K.; and Lee, R. 1991: Jet Noise Suppression. *Aeroacoustics of Flight Vehicles: Theory and Practice, Vol. 2: Noise Control*, H. Hubbard, ed., NASA RP-1258, pp. 207–269.
- Gottschalk, M. A. 1996: Going With the Flow. *Design News*, Sept. 9, pp. 23–24.
- Gray, J. 1936: Studies in Animal Locomotion: The Propulsive Power of the Dolphin. *J. Exp. Bio.*, vol. 13, pp. 192–199.
- Griffin, J.; Johnson, M. E.; and Fuller, C. R. 1998: Active Control of Transmission of Turbulent Boundary Layer Noise Using Smart Foam Elements. *J. Acoust. Soc. America*, vol. 104, no. 3, p. 1851.
- Groeneweg, J. F.; Sofrin, T. G.; Rice, E. J.; and Gliebe, P. R. 1991: Turbomachinery Noise. *Aeroacoustics of Flight Vehicles: Theory and Practice, Vol. 1: Noise Sources*, H. Hubbard, ed., NASA RP-1258, pp. 151–204.
- Grosskreutz, R. 1975: An Attempt to Control Boundary-Layer Turbulence With Non-Isotropic Compliant Walls. *Univ. Sci. J. Dar es Salaam*, vol. 1, pp. 65–73.
- Guin, M. M.; Kato, H.; and Takahashi, Y. 1998: Experimental Evidence for a Link Between Microbubble Drag Reduction Phenomena and Periodically Excited Wall-Bounded Turbulent Flow. *Proceedings of the International Symposium on Seawater Drag Reduction*, Office of Naval Research, pp. 313–318.
- Gyorgyfalvy, D. 1967: Possibilities of Drag Reduction by the Use of Flexible Skin. *J. Aircr.*, vol. 4, no. 3, pp. 186–192.
- Hedges, L. S.; Travin, A.; and Spalart, P. R. 2001: Detached-Eddy Simulations Over a Simplified Landing Gear. *J. Fluids Eng.* (In press)
- Hefner, J. N.; Weinstein, L. M.; and Bushnell, D. M. 1980: Large-Eddy Breakup Scheme for Turbulent Viscous Drag Reduction. *Viscous Flow Drag Reduction, Progress in Astronautics and Aeronautics*, Vol. 72, G. R. Hough, ed., AIAA, pp. 111–127.

- Holmes, B. J.; and Obara, C. J. 1992: Flight Research on Natural Laminar Flow Applications. *Natural Laminar Flow and Laminar Flow Control*, R. W. Barnwell and M. Y. Hussaini, eds., Springer-Verlag, pp. 73–142.
- Holmes, B. J.; Obara, C. J.; and Yip, L. P. 1984: *Natural Laminar Flow Experiments on Modern Airplane Surfaces*. NASA TP-2256.
- Hoyer, K. W.; and Gyr, A. 1996: Heterogeneous Drag Reduction Concepts and Consequences. ASME FED-Vol. 237, pp. 151–158.
- Hsiao, F.-B.; Wang, T.-Z.; and Zohar, Y. 1993: Flow Separation Control of a 2-D Airfoil by a Leading-Edge Oscillating Flap. *Pacific International Conference on Aerospace Science and Technology*, Vol. 1, National Chang Kung University, ROC, pp. 250–256.
- Huff, D. L. 1998: Fan Noise Prediction: Status and Needs. AIAA-98-0177.
- Hunter, C. A.; Viken, S. A.; Wood, R. M.; and Bauer, S. X. S. 2001: Advanced Aerodynamic Design of Passive Porosity Control Effectors. AIAA-2001-0249.
- Ingard, U.; and Labate, S. 1950: Acoustic Circulation Effects and the Nonlinear Impedance of Orifices. *J. Acoust. Soc. America*, vol. 22, no. 2, pp. 211–218.
- Jacobson, S. A.; and Reynolds, W. C. 1998: Active Control of Streamwise Vortices and Streaks in Boundary Layers. *J. Fluid Mech.*, vol. 360, pp. 179–211.
- Joslin, R. D. 1998a: *Overview of Laminar Flow Control*. NASA/TP-1998-208705.
- Joslin, R. D. 1998b: Aircraft Laminar Flow Control. *Ann. Rev. Fluid Mech.*, vol. 30, pp. 1–29.
- Joslin, R. D.; Horta, L. G.; and Chen, F.-J. 1999: Transitioning Active Flow Control to Applications. AIAA-99-3575.
- Joslin, R. D.; Kunz, R. K.; and Stinebring, D. R. 2000: Flow Control Technology Readiness: Aerodynamic Versus Hydrodynamic. AIAA-2000-4412.
- Joslin, R. D.; and Morris, P. J. 1992: The Effect of Compliant Walls on Secondary Instabilities in Boundary-Layer Transition. *AIAA J.*, vol. 30, no. 2, pp. 332–339.
- Joslin, R. D.; Morris, P. J.; and Carpenter, P. W. 1991: The Role of Three-Dimensional Instabilities in Compliant Wall Boundary-Layer Transition. *AIAA J.*, vol. 29, no. 10, pp. 1603–1610.
- Kenzakowski, D. C.; Shipman, J.; Dash, S. M.; Bridges, J. E.; and Saiyed, N. H. 2000: Turbulence Model Study of Laboratory Jets With Mixing Enhancements for Noise Reduction. AIAA-2000-0219.
- Khavaran, A.; Krejsa, E. A.; and Kim, C. M. 1994: Computation of Supersonic Jet Mixing Noise for an Axisymmetric Convergent-Divergent Nozzle. *J. Aircr.*, vol. 31, no. 3, pp. 603–609.
- Khorrani, M. R.; Berkman, M. E.; Choudhari, M.; Singer, B. A.; Lockard, D. P.; and Brentner, K. S. 1999: Unsteady Flow Computations of a Slat With a Blunt Trailing Edge. AIAA-99-1805.
- Kibens, V.; Dorris, J.; Smith, D. M.; and Mossman, M. F. 1999: Active Flow Control Technology Transition—The Boeing ACE Program. AIAA-99-3507.
- Koumoutsakos, P. 1995: Simulations of Vortex Generators. *Annual Research Briefs*, Stanford Univ. Center for Turbulence Research, pp. 233–240.

- Kraft, Christopher C. Commencement Address at Virginia Polytechnic Institute and State University, Blacksburg, VA, June 1982.
- Kramer, M. O. 1957: Boundary-Layer Stabilization by Distributed Damping. *J. Aeronaut. Sci.*, vol. 24, no. 6, pp. 459–460.
- Kramer, M. O. 1965: Hydrodynamics of the Dolphin. *Advances in Hydrosience*, Vol. 2, Academic Press, pp. 111–130.
- Krothapalli, A.; Venkatakrisnan, L.; Lourenco, L.; and Elavarasan, R. 2000: Supersonic Jet Noise Suppression by Water Injection. AIAA-2000-2025.
- Lachowicz, J. T.; Yao, C.; and Wlezien, R. W. 1998: Scaling of an Oscillatory Flow Control Actuator. AIAA-98-0330.
- Lachowicz, J. T.; Yao, C.; and Wlezien, R. W. 1999: Flow Field Characterization of a Jet and Vortex Actuator. *Exp. Fluids*, vol. 27, no. 1, pp. 12–20.
- Landahl, M. T. 1962: On the Stability of a Laminar Incompressible Boundary Layer Over a Flexible Surface. *J. Fluid Mech.*, vol. 13, pp. 609–632.
- Lane, D. A. 1996: Visualizing Time-Varying Phenomena in Numerical Simulations of Unsteady Flows. AIAA-96-0048.
- Latorre, R.; and Babenko, V. V. 1998: Role of Bubble Injection Technique Drag Reduction. *Proceedings of the International Symposium on Seawater Drag Reduction*, Office of Naval Research, pp. 319–325.
- Lauchle, G. C.; Petrie, H. L.; and Stinebring, D. R. 1995: Laminar Flow Performance of a Heated Body in Particle-Laden Water. *Exp. Fluids*, vol. 19, pp. 305–312.
- Lazos, B. S. 2001: Mean Flow Features Around the Inline Wheels of a Four Wheel Landing Gear. *AIAA J.* (In press)
- Lee, C. S.; Tavella, D.; Wood, N. J.; and Roberts, L. 1986: Flow Structure of Lateral Wing-Tip Blowing. AIAA-86-1810.
- Lee, C. S.; Tavella, D.; Wood, N. J.; and Roberts, L. 1989: Flow Structure and Scaling Laws in Lateral Wing-Tip Blowing. *AIAA J.*, vol. 27, no. 8, pp. 1002–1007.
- Lee, S. 1993: Effect of Leading-Edge Porosity on Blade-Vortex Interaction Noise. AIAA-93-0601.
- Lee, T.; Fisher, M.; and Schwarz, W. H. 1995: Investigation of the Effects of a Compliant Surface on Boundary-Layer Stability. *J. Fluid Mech.*, vol. 288, pp. 37–58.
- Lighthill, J. 1954: On Sound Generated Aerodynamically: I. General Theory. *Proc. R. Soc. London*, ser. A, vol. 211, no. 1148, pp. 1–32.
- Lin, J. C. 1999: Control of Turbulent Boundary-Layer Separation Using Micro-Vortex Generators. AIAA-99-3404.
- Lin, J. C.; Robinson, S. K.; McGhee, R. J.; and Valarezo, W. O. 1994: Separation Control on High-Lift Airfoils via Micro-Vortex Generators. *J. Aircr.*, vol. 31, no. 6, pp. 1317–1323.
- Liu, C. K.; Kline, S. J.; and Johnston, J. P. 1966: *An Experimental Study of Turbulent Boundary Layer on Rough Walls*. Report MD-15, Stanford Univ.

- Macaraeg, M. G. 1998: Fundamental Investigations of Airframe Noise. AIAA-98-2224.
- Madavan, N. K.; Deutsch, S.; and Merkle, C. L. 1984: The Effect of Porous Material on Microbubble Skin Friction Reduction. AIAA-84-0348.
- Maddalon, D. V.; and Braslow, A. L. 1990: *Simulated-Airline-Service Flight Tests of Laminar-Flow Control With Perforated-Surface Suction System*. NASA TP-2966.
- Magill, J. C.; and McManus, K. R. 1998: Control of Dynamic Stall Using Pulsed Vortex Generator Jets. AIAA-98-0675.
- Malcolm, G. N. 1991: *Forebody Vortex Control. Special Course on Aircraft Dynamics at High Angles of Attack: Experiments and Modeling*. AGARD-R-776, pp. 6.1–6.40.
- Malcolm, G. N.; and Skow, A. M. 1986: Enhanced Controllability Through Vortex Manipulation on Fighter Aircraft at High Angles of Attack. AIAA-86-2277-CP.
- Mankabadi, R. R.; Hayder, M. E.; and Povinelli, A. 1994: Structure of Supersonic Jet Flow and Its Radiated Sound. *AIAA J.*, vol. 32, no. 5, pp. 897–905.
- Marble, F. E.; and Candel, S. M. 1975: Acoustic Attenuation in Fans and Ducts by Vaporization of Liquid Droplets. *AIAA J.*, vol. 13, no. 5, pp. 634–639.
- Marshall, L. 2000: Summary of Transition Results From the F-16XL-2 Supersonic Laminar Flow Control Experiment. AIAA-2000-4418.
- McLean, J. D.; Crouch, J. D.; Stoner, R. C.; Sakurai, S.; Seidel, G. E.; Feifel, W. M.; and Rush, H. M. 1999: *Study of the Application of Separation Control by Unsteady Excitation to Civil Transport Aircraft*. NASA/CR-1999-209338.
- McManus, K.; and Magill, J. 1996: Separation Control in Incompressible and Compressible Flows Using Pulsed Jets. AIAA-96-1948.
- McManus, K.; and Magill, J. 1997: Airfoil Performance Enhancement Using Pulsed Jet Separation Control. AIAA-97-1971.
- Mecham, M. 1996: 3M Thin Skin Tested by Airbus. *Aviation Week & Space Technol.*, vol. 145, no. 2, p. 34.
- Meifarth, K. U.; and Heinrich, S. 1992: The Environment for Aircraft With Laminar Flow Technology Within Airline Service. *First European Forum on Laminar Flow Technology*, AAAF, pp. 251–255.
- Meng, J. C. S.; and Uhlman, J. S., Jr. 1998: Microbubble Formation and Splitting in a Turbulent Boundary Layer for Turbulence Reduction. *Proceedings of the International Symposium on Seawater Drag Reduction*, Office of Naval Research, pp. 341–355.
- Merkle, C. L.; and Deutsch, S. 1989: Microbubble Drag Reduction. *Engineering, Volume 46: Frontiers in Experimental Fluid Mechanics*, M. Gad-el-Hak, ed., Springer-Verlag, pp. 291–335.
- Mitchell, B. E.; Lele, S. K.; and Moin, P. 1995: *Direct Computation of Sound Generated by Subsonic and Supersonic Axisymmetric Jets*. Tech. Rep. TF-66, Stanford Univ.
- Moore, W. A.; Skow, A. M.; and Lorincz, D. J. 1980: Enhanced Departure Spin Recovery of Fighter Aircraft Through Control of the Forebody Vortex Orientation. AIAA-80-0173.

- Motier, J. F.; Chou, L.-C.; and Kommareddi, N. 1996: Commercial Drag Reduction: Past, Present, and Future. ASME FED-Vol. 237, pp. 229–234.
- Murri, D. G.; and Rao, D. M. 1987: Exploratory Studies of Actuated Forebody Strakes for Yaw Control at High Angles of Attack. AIAA-87-2557.
- Nagamatsu, H. T.; and Orozco, R. D. 1984: Porosity Effect on Supercritical Airfoil Drag Reduction by Shock Wave Boundary Layer Control. AIAA-84-1682.
- Nickerson, J. D., Jr. 1986: A Study of Vortex Generators at Low Reynolds Numbers. AIAA-86-0155.
- Ng, T. T.; and Malcolm, G. N. 1991a: Aerodynamic Control Using Forebody Blowing and Suction. AIAA-91-0619.
- Ng, T. T.; and Malcolm, G. N. 1991b: Aerodynamic Control Using Forebody Strakes. AIAA-91-0618.
- Nordwall, B. D. 2000: Nanotechnology Extending Material Science Frontier. *Aviation Week & Space Technol.*, vol. 153, no. 10, pp. 89–90.
- Norris, G. 1994: Laminar Flow Control—Smooth and Supersonic. *Flight Int.*, vol. 145, no. 4421, pp. 32–33.
- North, D. M. 1998: F/A-18E/F Role Secure in Future Carrier Wings. *Aviation Week & Space Technol.*, vol. 149, no. 9, pp. 50–55.
- Novak, C. J.; Cornelius, K. C.; and Roads, R. K. 1987: Experimental Investigations of the Circular Wall Jet on a Circulation Control Airfoil. AIAA-87-0155.
- O'Rourke, M. J. 1995: Experimental Investigation of Slot Blowing for Yaw Control on a Generic Fighter Configuration With a Chined Forebody. AIAA-95-1798.
- O'Rourke, M. J.; Ralston, J. N.; Kloc, S. J.; and Langan, K. J. 1996: Development of a Conformal Pneumatic Forebody Control for Next-Generation Fighters. AIAA-96-0786.
- O'Rourke, M. J.; and Sedor, J. L. 1995: Forebody-Mounted Jet Nozzles for Yaw Control on a Generic Fighter Configuration With a Chined Forebody. AIAA-95-3490.
- Ott, J. 2001: Europe Seeks New Noise Standard. *Aviation Week & Space Technol.*, vol. 154, no. 1, pp. 53–54.
- Oyler, T. E.; and Palmer, W. E. 1972: *Exploratory Investigation of Pulse Blowing for Boundary Layer Control*. Rep. No. NR 72H-12, North American Rockwell Corp.
- Pack, L. G.; and Seifert, A. 1999: Periodic Excitation for Jet Vectoring and Enhanced Spreading. AIAA-99-0672.
- Padula, S. L.; Rogers, J. L.; and Raney, D. L. 2000: Multidisciplinary Techniques and Novel Aircraft Control Systems. AIAA-2000-4848.
- Parikh, P. G.; and Nagel, A. L. 1990: *Application of Laminar Flow Control to Supersonic Transport Configurations*. NASA CR-181917.
- Peake, D. J.; Johnson, D. A.; and Owens, F. K. 1980: Control of Forebody Vortex Orientation to Alleviate Sideforces. AIAA-80-0183.
- Petrie, H. L.; Brungart, T. A.; and Fontaine, A. A. 1996: Drag Reduction on a Flat Plate at High Reynolds Number With Slot-Injected Polymer Solutions. ASME FED-Vol. 237, pp. 3–9.

- Powell, A. G. 1987: The Right Wing of the L.E.F.T. Airplane. *Research in Natural Laminar Flow and Laminar-Flow Control*, J. N. Hefner and F. E. Sabo, eds., NASA CP-2487, pt. 1, pp. 141–161.
- Powell, A. G.; Agrawal, S.; and Lacey, T. R. 1989: *Feasibility and Benefits of Laminar Flow Control on Supersonic Cruise Airplanes*. NASA CR-181817.
- Powell, C. A.; and Preisser, J. S. 1999: Research for Quieter Skies. *Aerosp. America*, vol. 37, no. 8, pp. 26–29.
- Pugliese, A. J.; and Englar, R. J. 1979: Flight Testing the Circulation Control Wing. AIAA-79-1791.
- Raman, G. 1999: Supersonic Jet Screech: Half-Century From Powell to the Present. *J. Sound & Vib.*, vol. 225, no. 3, pp. 543–571.
- Raman, G.; and McLaughlin, D. K. 1999: Highlights of Aeroacoustics Research in the U.S.—1998. AIAA-99-1915.
- Rangwalla, A. A.; and Rai, M. M. 1993: A Numerical Analysis of Tonal Acoustics in Rotor-Stator Interaction. *J. Fluids & Struct.*, vol. 7, pp. 611–637.
- Reischman, M. M. 1984: A Review of Compliant Coating Drag Reduction Research at ONR. *Laminar-Turbulent Boundary Layers*, Vol. 11, E. M. Uram and H. E. Weber, eds., ASME, pp. 99–105.
- Reshotko, E. 1979: Drag Reduction by Cooling in Hydrogen-Fueled Aircraft. *J. Aircr.*, vol. 16, pp. 584–590.
- Riley, J. J.; Gad-el-Hak, M.; and Metcalfe, R. W. 1988: Compliant Coatings. *Ann. Rev. Fluid Mech.*, vol. 20, pp. 393–420.
- Robert, J.-P. 1992: Hybrid Laminar Flow Control—A Challenge for a Manufacturer. *First European Forum on Laminar Flow Technology*, AAAF, pp. 294–308.
- Robinson, J. H. 1999: Shape Optimization of Cylindrical Shell for Interior Noise. *OptiCON 1999*, pp. 1–8.
- Roth, J. R.; Sherman, D. M.; and Wilkinson, S. P. 1998: Boundary Layer Flow Control With a One Atmosphere Uniform Glow Discharge Surface Plasma. AIAA-98-0328.
- Roos, F. W. 1996a: Microblowing for High-Angle-of-Attack Vortex Flow Control on a Fighter Aircraft. AIAA-96-0543.
- Roos, F. W. 1996b: Microblowing for Vortex Asymmetry Management on a Hemisphere-Cylinder Forebody. AIAA-96-1951.
- Roos, F. W. 1997: Synthetic-Jet Microblowing for Vortex Asymmetry Management on a Hemisphere-Cylinder Forebody. AIAA-97-1973.
- Roos, F. W. 1998: Synthetic-Jet Microblowing for Forebody Flow-Asymmetry Management. AIAA-98-0212.
- Roos, F. W.; and Magness, C. L. 1993: Bluntness and Blowing for Flowfield Asymmetry Control on Slender Forebodies. AIAA-93-3409.
- Ross, A. J.; Jefferies, E. B.; and Edwards, G. F. 1990: *Control of Forebody Vortices by Suction at the Nose of the RAE High Incidence Research Model*. AGARD-CP-494.
- Ross, C. F.; and Purver, M. R. J. 1997: Active Cabin Noise Control. *Active 97*, Inst. Noise Control Eng., pp. 39–46.

- Rumsey, C. L.; Biedron, R. T.; Farassat, F.; and Spence, P. L. 1998: Ducted-Fan Engine Acoustic Predictions Using a Navier-Stokes Code. *J. Sound & Vib.*, vol. 213, no. 4, pp. 643–664.
- Rumsey, C. L.; Biedron, R. T.; and Thomas, J. T. 1997: *CFL3D: Its History and Some Recent Applications*. NASA TM-112861.
- Saddoughi, S. G. 1995: Preliminary Results of the “On-Demand” Vortex-Generator Experiments. *Annual Research Briefs*, Stanford Univ. Center for Turbulence Research, pp. 227–232.
- Saddoughi, S. G.; Koumoutsakos, P.; Bradshaw, P.; and Mansour, N. N. 1998: *Investigations of On-Demand Vortex Generators*. Research Man. No. 171, Stanford Univ. Center for Turbulence Research.
- Saiyed, N. H.; Bridges, J. E.; and Mikkelsen, K. L. 2000: Acoustics and Thrust of Separate-Flow Exhaust Nozzles With Mixing Devices for High-Bypass-Ratio Engines. AIAA-2000-1961.
- Salas, A. O.; and Townsend, J. C. 1998: Framework Requirements for MDO Application Development. AIAA 98-4740.
- Saric, W.; Carillo, R.; and Reibert, M. 1998: Leading Edge Roughness as a Transition Control Mechanism. AIAA-98-0781.
- Savu, G.; and Trifu, O. 1984: Porous Airfoils in Transonic Flow. *AIAA J.*, vol. 22, no. 7, pp. 989–991.
- Scott, W. B. 2000: Sandia Expands Envelope of MEMS Devices. *Aviation Week & Space Technol.*, vol. 152, no. 24, pp. 57–58.
- Seasholtz, R. G.; and Panda, J. 2000: Rayleigh Scattering Diagnostic for Simultaneous Measurements of Dynamic Density and Velocity. AIAA-2000-0642.
- Seifert, A.; Bachar, T.; Koss, D.; Shepshelovich, M.; and Wygnanski, I. 1993: Oscillatory Blowing: A Tool to Delay Boundary-Layer Separation. *AIAA J.*, vol. 31, no. 11, pp. 2052–2060.
- Seifert, A.; Bachar, T.; Wygnanski, I.; Kariv, A.; Cohen, H.; and Yoeli, R. 1998: Application of Active Separation Control to a Small Unmanned Air Vehicle. *J. Aircr.*, vol. 36, no. 2, pp. 474–477.
- Seifert, A.; Darabi, A.; and Wygnanski, I. 1996: Delay of Airfoil Stall by Periodic Excitation. *J. Aircr.*, vol. 33, no. 4, pp. 691–698.
- Seifert, A.; Eliahu, S.; Greenblatt, D.; and Wygnanski, I. 1998: Use of Piezoelectric Actuators for Airfoil Separation Control. *AIAA J.*, vol. 36, no. 8, pp. 1535–1537.
- Seifert, A.; and Pack, L. G. 1999a: Oscillatory Excitation of Unsteady Compressible Flows Over Airfoils at Flight Reynolds Numbers. AIAA-99-0925.
- Seifert, A.; and Pack, L. G. 1999b: Oscillatory Control of Separation at High Reynolds Numbers. *AIAA J.*, vol. 33, no. 9, pp. 1062–1071.
- Seiner, J. M. 1998: A New Rational Approach to Jet Noise Reduction. *Theoretical and Computational Fluid Dynamics*, Vol. 10, Springer Int., pp. 373–383.
- Seiner, J. M.; Ukeiley, L.; and Ponton, M. K. 1999: Jet Noise Source Measurements Using PIV. AIAA-99-1869.
- Shen, H.; and Tam, C. K. W. 1998: Numerical Simulations of the Generation of Axisymmetric Mode Jet Screech Tones. AIAA-98-0283.

- Simonich, J. C.; Narayanan, S.; Barber, T. J.; and Nishimura, M. 2000: High Subsonic Jet Experiments Part I: Aeroacoustic Characterization, Noise Reduction and Dimensional Scaling Effects. AIAA-2000-2022.
- Simpson, J. O.; Wise, S. A.; Bryant, R. G.; Cano, R. J.; Gates, T. S.; Hinkley, J. A.; Rogowski, R. S.; and Whitley, K. S. 1998: Innovative Materials for Aircraft Morphing. *SPIE Fifth International Symposium on Smart Structures and Materials*.
- Smith, B. L.; and Glezer, A. 1998: The Formation and Evolution of Synthetic Jets. *Phys. Fluids*, vol. 10, no. 9, pp. 2281–2297.
- Sparaco, P. 2001: Europe Embarks on \$11-Billion A380 Gamble. *Aviation Week & Space Technol.*, vol. 154, no. 1, pp. 22–25.
- Storms, B.; Jaeger, S.; Hayes, J.; and Soderman, P. 2000: Aeroacoustic Study of Flap-Tip Noise Reduction Using Continuous Moldline Technology. AIAA-2000-1976.
- Storms, B. L.; Ross, J. C.; Hayes, J. A.; Dougherty, R. P.; Underbrink, J. R.; Scharpf, D. F.; and Moriarty, P. J. 1998: *An Aeroacoustic Study of an Unswept Wing With a Three-Dimensional High Lift System*. NASA/TM-1998-112222.
- Strazisar, A. J.; Reshotko, E.; and Prah, J. M. 1977: Experimental Study of the Stability of Heated Laminar Boundary Layers in Water. *J. Fluid Mech.*, vol. 83, pt. 2, pp. 225–247.
- Streett, C. L. 1998: Numerical Simulation of a Flap-Edge Flowfield. AIAA-98-2226.
- Subaschandar, N.; Kumar, R.; and Sundaram, S. 1999: Drag Reduction Due to Riblets on a GAW(2) Airfoil. *J. Aircr.*, vol. 36, no. 5.
- Sutliff, D. L.; Curtis, A. R. D.; Heidelberg, L. J.; and Remington, P. J. 2000: Performance of an Active Noise Control System for Fan Tones Using Vane Actuators. AIAA-2000-1906.
- Tam, C. K. W. 1991: Jet Noise Generated by Large Scale Coherent Motion. *Aeroacoustics of Flight Vehicles: Theory and Practice, Volume 1: Noise Sources*, H. Hubbard, ed., NASA RP-1258, pp. 311–390.
- Tanna, H. K. 1977: An Experimental Study of Jet Noise—Part II: Shock Associated Noise. *J. Sound & Vib.*, vol. 50, no. 3, pp. 429–444.
- Tardu, S. 1998: Local Oscillating Blowing in a Turbulent Boundary Layer. *Proceedings of the International Symposium on Seawater Drag Reduction*, Office of Naval Research, pp. 241–248.
- Taylor, H. D.; and Hoadley, H. H. 1948: *Application of Vortex Generator Mixing Principle to Diffusers*. Rep. R-15064-5, United Aircraft Corp.
- Taylor, H. D.; and Hoadley, H. H. 1948: *Design Criteria for and Applications of the Vortex Generator Mixing Principle*. Rep. M-15038-1, United Aircraft Corp.
- Thibert, J. J.; Reneaux, V.; and Schmitt, V. 1990: ONERA Activities in Drag Reduction. *Proceedings of 17th Congress International Council of the Aeronautical Sciences*, Vol. 1, ICASE, pp. 1053–1064.
- Thomas, R. H.; Kinzie, K. W.; and Pao, S. P. 2001: Computational Analysis of a Pylon-Chevron Core Nozzle Interaction. AIAA-2001-2185.

- Tufo, H. M.; Fischer, P. F.; Papka, M. E.; and Blom, K. 1999: Numerical Simulation and Immersive Visualization of Hairpin Vortices. *Proceedings of the ACM/IEEE SC99 Conference on High Performance Networking and Computing*, IEEE Computer Society, CD-ROM.
- Tuttle, M. H.; and Maddalon, D. V. 1982: *Laminar Flow Control (1976–1982)—A Selected, Annotated Bibliography*. NASA TM-84496.
- Tuttle, M. H.; and Maddalon, D. V. 1993: *Laminar Flow Control (1976–1991)—A Comprehensive, Annotated Bibliography*. NASA TM-107749.
- Virk, P. S. 1975: Drag Reduction Fundamentals. *AIChE J.*, vol. 21, pp. 625–656.
- Virk, P. S.; Mickley, H. S.; and Smith, K. A. 1970: The Ultimate Asymptote and Mean Flow Structure in Toms' Phenomenon. *J. Appl. Mech.*, vol. 37, no. 2, pp. 488–493.
- Virk, P. S.; Wagger, D. L.; and Koury, E. 1996: The Asymptotic Maximum Drag Reduction Induced by Additives in Internal Flows, ASME FED-Vol. 237, pp. 261–276.
- Wagner, R. D.; Maddalon, D. V.; Bartlett, D. W.; and Collier, F. S., Jr. 1988: *Fifty Years of Laminar Flow Flight Testing*. SAE Paper 881393.
- Walsh, M. J. 1980: Drag Characteristics of V-Groove and Transverse Curvature Riblets. *Viscous Flow Drag Reduction, Progress in Astronautics and Aeronautics*, Vol. 72, Gary R. Hough, ed., AIAA, pp. 169–184.
- Walsh, M. J. 1982: Turbulent Boundary Layer Drag Reduction Using Riblets. AIAA-82-0169.
- Walsh, M. J. 1990: Riblets. *Viscous Flow Drag Reduction, Progress in Astronautics and Aeronautics*, Vol. 123, D. M. Bushnell and J. Hefner, eds., AIAA, pp. 203–261.
- Walsh, M. J.; and Lindemann, A. M. 1984: Optimization and Application of Riblets for Turbulent Drag Reduction. AIAA-84-0347.
- Walsh, M. J.; Sellers, W. L., III; and McGinley, C. B. 1988: Riblet Drag Reduction at Flight Conditions. AIAA-88-2554.
- Wentz, W. H.; Holmes, B. J.; Ahmed, A.; and Nyenhuis, R. 1985: *Further Results of Natural Laminar Flow Flight Test Experiments*. SAE Paper 850862.
- Wetzel, T. G.; and Simpson, R. L. 1998: Effects of Fin and Jet Vortex Generators on the Crossflow. *J. Aircr.*, vol. 35, no. 3, pp. 370–379.
- Wilcox, F. J. 1990: *Experimental Investigation of the Effects of a Porous Floor on Cavity Flow Fields at Supersonic Speeds*. NASA TP-3032.
- Willis, G. J. K. 1986: Hydrodynamic Stability of Boundary Layers Over Compliant Surfaces. Ph.D. Thesis, University of Exeter.
- Wiltse, J. M.; and Glezer, A. 1993: Manipulation of Free Shear Flows Using Piezoelectric Actuators. *J. Fluid Mech.*, vol. 249, pp. 261–285.
- Woan, C. J.; Gingrich, P. B.; and George, M. W. 1991: CFD Validation of a Supersonic Laminar Flow Control Concept. AIAA-91-0188.

- Wood, R. M.; Banks, D. W.; and Bauer, S. X. S. 1992: Assessment of Passive Porosity With Free and Fixed Separation on a Tangent Ogive Forebody. AIAA-92-4494.
- Wortman, A. 1987: *Alleviation of Fuselage Form Drag Using Vortex Flows*. Rep. DOE/CE/15277-T1, U.S. Dep. Energy.
- Wu, J. M.; Vakili, A.; Chen, Z. L.; and Gilliam, F. T. 1983: Investigation on the Effects of Discrete Wingtip Jets. AIAA-83-0546.
- Wu, J. M.; Vakili, A. D.; and Gilliam, F. T. 1984: Aerodynamic Interactions of Wingtip Flow With Discrete Wingtip Jets. AIAA-84-2206.
- Yaros, S. F.; Sexstone, M. G.; Huebner, L. D.; Lamar, J. E.; McKinley, R. E.; Torres, A. O.; Burley, C. L.; Scott, R. C.; and Small, W. J. 1998: *Synergistic Airframe-Propulsion Interactions and Integrations*. NASA/TM-1998-207644.
- Yeo, K. S. 1986: The Stability of Flow Over Flexible Surfaces. Ph.D. Thesis, University of Cambridge.

REPORT DOCUMENTATION PAGE

Form Approved
OMB No. 0704-0188

Public reporting burden for this collection of information is estimated to average 1 hour per response, including the time for reviewing instructions, searching existing data sources, gathering and maintaining the data needed, and completing and reviewing the collection of information. Send comments regarding this burden estimate or any other aspect of this collection of information, including suggestions for reducing this burden, to Washington Headquarters Services, Directorate for Information Operations and Reports, 1215 Jefferson Davis Highway, Suite 1204, Arlington, VA 22202-4302, and to the Office of Management and Budget, Paperwork Reduction Project (0704-0188), Washington, DC 20503.

1. AGENCY USE ONLY (Leave blank)	2. REPORT DATE April 2002	3. REPORT TYPE AND DATES COVERED Technical Memorandum	
4. TITLE AND SUBTITLE Flow and Noise Control: Review and Assessment of Future Directions		5. FUNDING NUMBERS WU 781-10-12-01	
6. AUTHOR(S) Russell H. Thomas, Meelan M. Choudhari, and Ronald D. Joslin			
7. PERFORMING ORGANIZATION NAME(S) AND ADDRESS(ES) NASA Langley Research Center Hampton, VA 23681-2199		8. PERFORMING ORGANIZATION REPORT NUMBER L-18172	
9. SPONSORING/MONITORING AGENCY NAME(S) AND ADDRESS(ES) National Aeronautics and Space Administration Washington, DC 20546-0001		10. SPONSORING/MONITORING AGENCY REPORT NUMBER NASA/TM-2002-211631	
11. SUPPLEMENTARY NOTES Thomas and Choudhari: Langley Research Center, Hampton, VA; Joslin: Pennsylvania State University, State College, PA.			
12a. DISTRIBUTION/AVAILABILITY STATEMENT Unclassified-Unlimited Subject Category 71 Availability: NASA CASI (301) 621-0390		12b. DISTRIBUTION CODE	
13. ABSTRACT (Maximum 200 words) Technologies for developing radically new aerovehicles that would combine quantum leaps in cost, safety, and performance benefits with environmental friendliness have appeared on the horizon. This report provides both an assessment of the current state-of-the-art in flow and noise control and a vision for the potential gains to be made, in terms of performance benefit for civil and military aircraft and a unique potential for noise reduction, via future advances in flow and noise technologies. This report outlines specific areas of research that will enable the breakthroughs necessary to bring this vision to reality. Recent developments in many topics within flow and noise control are reviewed. The flow control overview provides succinct summaries of various approaches for drag reduction and improved maneuvering. Both exterior and interior noise problems are examined, including dominant noise sources, physics of noise generation and propagation, and both established and proposed concepts for noise reduction. Synergy between flow and noise control is a focus and, more broadly, the need to pursue research in a more concurrent approach involving multiple disciplines. Also discussed are emerging technologies such as nanotechnology that may have a significant impact on the progress of flow and noise control.			
14. SUBJECT TERMS Flow and noise control review; Emerging aerospace technology; Synergy between flow and noise control		15. NUMBER OF PAGES 96	
		16. PRICE CODE	
17. SECURITY CLASSIFICATION OF REPORT Unclassified	18. SECURITY CLASSIFICATION OF THIS PAGE Unclassified	19. SECURITY CLASSIFICATION OF ABSTRACT Unclassified	20. LIMITATION OF ABSTRACT UL