

FLOW INDUCED SPRING COEFFICIENTS OF LABYRINTH
SEALS FOR APPLICATION IN ROTOR DYNAMICS

H. Benckert and J. Wachter
Institut für Thermische Strömungsmaschinen
Universität Stuttgart
Stuttgart, Germany

SUMMARY

Self-excited rotor vibrations which are a function of output are being increasingly observed in high-performance turbo-machinery, in particular high-pressure compressors. The labyrinth lateral force components of the rotor loadings, which are related to the unequal pressure patterns over the circumference of the contactless sealings by an eccentric shaft location, are one possible reason for the self excitation.

The investigations presented in this paper deal with the flow induced aerodynamic spring coefficients of labyrinth seals, with the restoring force in the deflection plane of the rotor and the lateral force acting perpendicularly to it. The discussion includes the effects of operational conditions on the spring characteristics of these components, such as differential pressure, speed, inlet flow conditions and the geometry of the labyrinth seals.

Estimation formulas for the lateral forces due to shaft rotation and inlet swirl, which are developed through experiments, are presented. The utilisation of the investigations is explained and results of stability calculations, especially for high pressure centrifugal compressors, are added. Remarks about possibilities to avoid the exciting forces in labyrinths will finish this report.

INTRODUCTION

Non-contacting labyrinth-type seals are conventional design elements in turbo-machinery which have proved their value for a considerable period of time. Until today, investigations of labyrinth seals gave priority to the improvement of the sealing effect. Labyrinth seals in these investigations have been considered as a series of throttling points controlling leakage flow. A comprehensive equation to determine mass flow through the labyrinth was published by "Stodola" (ref.1).

However, the user of a turbomachinery is not only affected by the economic value of the labyrinths due to leakage losses, but also has to consider the limitation of the operation range of the plant, because the rotor dynamics are influenced by forces created in labyrinth seals. These forces result from the ununiform pressure distributions on the circumference of the contact free seals, where the clearance differ on the circumference of the shaft with the shaft in a out-of-centre position. In the case of thermal turbomachinery of high energy density - energy conversion in respect to rotor mass - the forces resulting from non-symmetrical aerodynamics in the labyrinth gaps cannot be neglected in the rotor dynamic evaluation, since the lateral force components of these forces acting

vertical to the rotor eccentricity plane can be the source of self excited flexural vibrations of the shaft. Reference 2 is showing for the high pressure part of a steam turbine, how suddenly the lateral forces can change the vibration pattern of the turbomachinery. The points of attack of the exciting lateral forces are distributed over the length of the rotor, according to the positions of the sealing gaps. The self exciting mechanism of contact free seals is comparable to the gap excitation of impellers (ref.3,4). The reason for both gaps excitations is based on the aerodynamics of the fluid (aerodynamic excitation) and tend to occur as a function of load at constant speed.

DEFINITION OF THE PROBLEM

The importance of the aerodynamic forces due to eccentric seal gaps in thermal turbomachinery was underestimated until now, in respect to the effect on rotor dynamics. It was assumed that a pressure difference in the individual labyrinth chambers would equalize itself rapidly. Basing on this assumption, it would be possible to practically neglect this phenomena as a potential cause acting on the rotor.

The excitation of the rotor by aerodynamic forces from labyrinth seals was described in first time for a labyrinth seal with one sealing chamber by "Alford" (ref.5). This work yields that vibrations of the shaft induce lateral forces within the seal, which move the shaft asynchronously and therefore may start instabilities. Important for this theory is the difference in gap width between inlet and outlet labyrinth tip; circumferential flows in the chamber are neglected. Another theoretical study (ref.6) also investigated the flow through a labyrinth with one chamber and its effects on the dynamics of the rotor. Here the influence of the drag effect by the rotating shaft on the flow was not considered. Results of experiments of different labyrinths with one sealing chamber are described in reference 7. The measurements are in respect to the dynamic behavior of a whirling rotor due to the instationary forces in the flow.

Besides lateral forces in the labyrinths caused by the dynamic behaviour of the whirling rotor (Alford effect), pressure distributions also appear in the sealing chambers, when the rotor has a stationary eccentricity. The resulting lateral forces from these pressure distributions can have a destabilizing influence on the dynamic of the rotor. It could be proved that the existence of a resulting lateral force from the pressure distribution in the labyrinth chambers is related to circumferential velocities of the fluid in the seal. Due to the action of the diffusors and the rotation of the rotor, flow through the labyrinth seal is imparted a circumferential component in the direction of rotation whereby the maximum pressure in the spaces between the sealing strips is displaced in a direction opposite the direction of rotation at a point ahead of the narrowest clearance.

"Kostyuk, 1972" (ref.8) presented a theoretical approach to determine the aerodynamic forces in the labyrinth seal with a shaft not parallel to the centerline. According to this model the circumferential flows in the chambers are dependent from the friction ratio between stator and rotor. Based on this friction ratio a constant mean circumferential velocity can be calculated for each chamber. "Rosenberg a.o." (ref.9) described the dominant effect of the spiral flow on the gap flow forces. According to him, the spiral flow effect dominates the

friction effect within the seal. This model was used in ref. 10 to calculate the labyrinth gap flow induced forces on the rotor.

The present results of investigations (ref. 7,9,10), and also newer ones (ref.11), are limited however to very short labyrinth seals with 1 to 3 chambers, as they are commonly used in thermal turbomachinery for impeller sealing. The noted vibration problems at steam turbines (ref.2,12), give indication that besides the gap excitation due to ununiform energy conversion of blade cascade (ref.3) and the lateral forces due to the short impeller seals, the latter being considerably larger than the former (ref.13), also the other labyrinth seals of a turbomachinery influence the dynamic behavior of the rotor. Especially the multichamber designs of shaft end seals and balance piston seals earn attention in this respect. These problems were most pronounced in the case of high-pressure centrifugal compressors (ref.14). Because of the high density and the swirl components in such machines the labyrinths are entered with a considerable inlet swirl, while in longer seals the shaft rotation induces circumferential flows. Investigations of the dynamic behavior of such labyrinth assemblies with a large numbers of chambers, often also with a high pressure difference and considerable compressibility effect, have not been generally available for the user.

To get better know-how about the forces due to gap flow in labyrinth seals, the investigations at the "Institut für Thermische Strömungsmaschinen at the University of Stuttgart" are performed. This is done with the aim to point out the effects of operating parameters on the pressure distribution in the chambers, by investigating different non-contacting labyrinth seals. Integrating the pressure over the circumference of the chambers results in a total force, radial to the shaft, the two components of which - the restoring force opposite to the shaft displacement and the lateral force acting vertical to the shaft deflection plane - have to be investigated independently due to their different influence on the vibration behavior of the rotor. While the restoring force is of minor importance, because she does not induce self excitation, the lateral force components of the labyrinths may well be the cause for instabilities of turbomachines.

The investigations introduced in this paper result in labyrinth spring constants in relation to operational boundary conditions of the seal assemblies. In contrary to previous research work, a separate investigation was performed for multichamber labyrinths of different designs with static eccentricity of the rotor but without considering the rotor not to be parallel to the centerline. The achieved test results, first published, in part, already in 1978 (ref.15), shall contribute to a better understanding of the forces due to clearance flow in conventional labyrinth, to give a more differentiated view of the flow induced causes for self excitation in turbomachinery (ref.16).

The research work for the investigations of labyrinths have been sponsored by the "Forschungsvereinigung Verbrennungskraftmaschinen e.v., Frankfurt am Main" and the "KSB-Foundation, Stuttgart". Gratitude is also due to "Mannesmann - DEMAG, Duisburg", for the support to establish this paper.

EXPERIMENTAL SETUP

For the investigations, a test stand was needed, the design and fabrication of which was jointly done together with the manufacturers of turbomachines, engaged in these labyrinth studies. The test stand is shown in the cross section drawing of figure 1. Shown is a straight through labyrinth seal (half labyrinth) with plain shaft and mortised sealing tips in the casing. Each chamber of the labyrinth insert is equipped with twelve holes for static pressure measurements, which are arranged every 30 degrees over the circumference. The seal flow enters the test labyrinth from the top. Several inlet elements are available to vary the entry swirl at the inlet. The working fluid is air, which is expanded to the ambient conditions. The shaft circumferential speed is continuously adjustable ($u_w \text{ max}=150 \text{ m/s}$). The rotor eccentricity can be arbitrarily selected within the mean gap width Δr .

The pressure measurement is done with range calibrated differential-pressure voltage-transformers. The measured values totalling 216, of which 188 are pressures, are collected by a data acquisition system. A central process computer controls the measuring system installed on the test stand and processes the digital measured values for pressure, temperature, leakage flow through the seal and rotor speed. The data output for test evaluation on the large capacity computer is selectable.

The influence of the following operation parameters on the pressure distribution in the chambers in circumferential and axial direction have been defined in the experimental investigations:

- pressure difference ratio p_a/p_o
- entry state of the first seal strip ρ_o, c_{uo}
- rotor excentricity ϵ
- geometry $\Delta r, t, h$ and number m of chambers
- rotor circumferential speed $\pm u_w$

In this manner different labyrinth designs have been investigated. The mass flow throughput is additionally measured for every test point and was described in respect to the axial pressure distribution separably in reference 17. A detailed description of the test bed concept as well as a explanation of the measuring techniques and the testing procedures is given in reference 18.

EVALUATION

Based on the characteristic pressure distribution of figure 2, the interpretatiom method for the labyrinth investigation shall be explained. Characteristic pressure distributions for a labyrinth seal with two whirling chambers are shown in this diagram. The local pressure is related to the static pressure drop. Around the circumference of the seal, the static pressures of the chambers are measured in a distance of 30 degrees. The circumference angle $\phi = 0$ is the position of the widest gap. The centerline is parallel to the eccentric rotor. A non-parallel position of the rotor to the centerline can also be considered. The normal forces (Q and R), which act on the shaft, are the components of the force resulting from the pressure distribution. Since the pressure distributions in the chambers

($p_i(\phi)$) are periodic phenomena around the rotor circumference, the evaluation by means of a Fourier development seems to be useful. The normal forces of a whirling chamber emerge as:

$$Q = r \cdot t \cdot \int_0^{2\pi} p_i(\phi) \sin \phi \, d\phi \quad R = - r \cdot t \cdot \int_0^{2\pi} p_i(\phi) \cos \phi \, d\phi \quad (1)$$

The utilized pressure integration method proved to be useful for the tests, since in this way also minimal changes of the basic vibrations have been graphed. The resulting normal forces emerge out of the summation of all chambers. For the systematic evaluation and presentation of the results however, a related representation of forces (related force: $F_B = r \cdot m \cdot t \cdot (p_o - p_a)$) for the lateral force (\bar{Q}^*) and the restoring force (\bar{R}^*) is recommendable. For different labyrinths, the force displacements curves for both forces have been graphed by varying the rotor excentricity (lateral force in fig.3). The gradients of the "Labyrinth spring characteristic curves" result in the "labyrinth spring constants" for the application in rotor dynamics, as defined in equation 2 for the related force spring constant.

$$\bar{K}_Q^* = d \bar{Q}^* / d\epsilon \quad (2)$$

The assumption of a linear relation between the forces and the rotor deflection is a supposition for the definition of the related force sensitivities. It could be proven that this is true for relative excentricity values of the lateral force component up to $\epsilon = e/\Delta r = 0,6$ to $0,7$. The linearity of the restoring force deflection-curves is generally valid only for values $\epsilon < 0,4$. The spring constants with dimensions of both components have to be calculated by means of the related force and the mean gap width. The lateral force excitation constant emerges as

$$K_Q = \bar{K}_Q^* \cdot F_B / \Delta r \quad (3)$$

RESULTS

The exciting lateral forces are induced by the circumferential velocity components of the flow in the whirling chambers. In the labyrinths, two causes have to be considered responsible for this condition:

1. By the drag effect of the shaft a circumferential flow is caused in the chambers.
2. By an inlet condition with entry swirl at the first labyrinth tip a circumferential component is carried over into the labyrinth.

Both causes coexist with each other in a turbomachine. The separation of both effects could be achieved by separate investigations as part of this research. Whereas the speed related lateral forces exist primarily in longer labyrinths, the preswirl components dominate in short labyrinths with only few whirling chambers ($m < 5$), as used commonly as impeller seals.

Lateral forces due to shaft rotation

The effects of the lateral forces in a labyrinth seal induced by the drag effect of the shaft are dependent from the friction ratio between stator and rotor in the whirling chambers. Following equality conditions a mean circumferential velocity develops in the chamber. For a labyrinth seal without axial pressure drop ($\Delta p_{st}=0$), this c_u -component is equal in each chamber and proportional to the circumferential speed of the shaft. The lateral and restoring forces resulting from the pressure distribution of the chambers are in a relationship of the square to the rotor velocity. The influence of speed is shown in figure 3 for a straight labyrinth without axial flow. Simultaneous this figure presents the influence of height of chamber. Along the rotor displacement the lateral forces are plotted. The slopes of these curves give the lateral force spring constants in the magnitude of $K_Q = 5-50$ N/mm. The listed measuring symbols are the average values of the pressure measurements from 17 whirling chambers out of two independent tests.

Similar results have been reached with investigations about the influence of shaft-rotation on the normal forces, when the seal had an axial flow due to an axial pressure difference (figure 4). For the circumferential component of the flow in the chambers a constant value for c_u along the whole length of the labyrinth cannot be assumed. Dependent on the mass flow, the conditions of the working fluid and the friction ratio in the seal, the circumferential flow will reach a constant velocity c_u at a certain chamber of the seal. The length of the seal, i.e. the number of chambers is therefore an important factor for the induction of lateral forces by rotation. Since the maximal number of chambers of the investigated labyrinths was 23, the results comprise the summation of all forces of the c_u -components - from starting up and the constant area of c_u . The direction of lateral force is dependent from rotation, whereas the restoring force is independent from rotation. This is further explained in the following. For the analysis of the rotation dependent lateral forces a related speed-flow value E_{ow}^* was defined (equation 4), in which the axial pressure drop entered with $\Delta p_{ges} = p_o - p_a + 0,5 \cdot \rho_o \cdot c_{ax}^2$.

$$E_{ow}^* = 0,25 (\rho_o + \rho_a) u_w^2 / \Delta p_{ges} \quad (4)$$

As a function of this value, figure 5 shows the characteristic curves of the related lateral force spring constants due to shaft rotation for two types of labyrinths. The listed symbols and the equation for K_{QW}^* are for the shown interlocking labyrinth design. For the investigated comb-and-groove seal, the short design ($m=10$ and 6) resulted in a low speed sensitivity. The factor k_A in the shown equation is the ratio between the propelling surfaces of the rotor and retarding surfaces of the stator. The value $k_{\Delta r} = \Delta r / l_{mm}$ includes the different gap width of the two labyrinth types. For sufficient long, i.e. multi-chamber labyrinth seals, the constant area of the circumference flow in the chambers is dominant, so that the relation between the speed u_w and the exciting lateral forces approach the limiting value:

$$K_{QW} \sim u_w^2 \quad (5)$$

Following from equation 4 this relation is equal to $K_{QW}^* \sim E_{ow}^*$ (fig.5).

Lateral forces due to entry swirl

The lateral forces due to entry swirl ($u_w=0$) are determined by the geometry and the flow boundary conditions at the seal entrance (figures 2 a. 6). The latter are covered by the relative admission energy E_o^* of the flow, which relates the volume-related swirl energy ahead of the first labyrinth tip to the existing total pressure drop:

$$E_o^* = 0,5 \cdot \rho_o \cdot c_u^2 / \Delta p_{ges} \quad (6)$$

Without entry swirl ($E_o^*=0$) no lateral forces occur in an eccentric labyrinth seal with the shaft stationary.

The lateral force spring constants resulting from the lateral force/displacement curves are, in their related representation (equation 2) corresponding to the relationship " $\bar{k}_Q^* \sim \sqrt{E_o^*}$ ", depended on the magnitude of the related entry energy (fig.7). The proportionality factor is determined by the geometric parameters of the seal ($h, \Delta r, m, t$) and the flow coefficient μ . The calculation of the flow coefficient for the individual seals was carried out by means of the equation 7, since the mass flow was measured for each test point. Taking into account the

$$\dot{m} = \mu \cdot A \cdot \sqrt{(p_o^2 - p_a^2)} / z \cdot p_o \cdot v_o \quad (7)$$

flow coefficient, the lateral forces due to preswirl can be calculated according to the equation in figure 8 for the different labyrinth designs. The mean height of the space between sealing strips covered by the equation is $h = 5-6$ mm with the factor $k_{\Delta r}$ indicating the effect of the clearance width in respect of $\Delta r=1$ mm. The dashed straight lines represent the scatter band of ± 8 % applying to the equation stated. The symbols entered result in each case from a lateral force/displacement characteristic with 5-7 test points versus rotor eccentricity. As the height of the spaces between the sealing strips becomes less, the lateral forces tend to increase (fig.6). This geometry parameter can be included for the relative lateral force excitation constant in the relationship plotted in fig.9. In conjunction with further geometry variables, the following relationship has been established for this parameter on the strength of tests made to date:

$$\bar{k}_Q^* \sim \Delta r \cdot \mu \cdot \sqrt{E_o^*} / m \cdot h \quad (8)$$

Restoring forces of labyrinth seals

Depending on the labyrinth configuration, the restoring forces are widely different. With seals having a number of spaces $m > 6-8$, restoring forces are mainly negative, i.e. decentering. In contrast with the lateral forces, they also tend to occur without entry swirl and shaft rotation (fig.10). The amount of negative restoring forces increases as the shaft circumferential velocity increases. Independent of the direction of rotor rotation, the force provides decentering action in the direction of the shaft displacement (fig.4). In the case of the interlocking labyrinth-type seal, the relative restoring force spring constants were found to be similar to the lateral force spring constants as a function of the speed-flow index E_{ow}^* . For multichamber labyrinths, the influence of the chamber circumferential flow by rotor rotation was confirmed, since the negative restoring forces increase considerably due to inertia conditions (fig.10).

Therefore, the chamber specific c_u -component is responsible for the decentering parts of the restoring forces along the chambers. Restoring forces centering the rotor could only be detected in the first whirling chamber of the individual labyrinth designs investigated. All further whirling chambers have been slightly decentering and therefore dominating in the summation of the total seal.

APPLICATION

A general impression of the effects of the flow parameter referred to on the dynamic behaviour of labyrinths can be seen in fig. 11 by the example of an interlocking labyrinth. Normally in turbomachinery, a coexistence of lateral forces from entry swirl flow and from shaft rotation has to be accounted for. For a first evaluation of values, an addition of the swirl and speed related components can be done as an approximation. Figure 12 shows the influences of the most important values on the lateral force sensitivity for tests with shaft rotation and entry swirl. With increasing shaft circumferential speed - pressure ratio constant - the lateral force spring constants are growing. For the axial pressure drop, the following statement can be made: the inducing influence of the rotor speed on the related lateral force is growing with smaller pressure difference and therefore with smaller leakage flow while the other conditions are constant.

Makers of turbo-machinery participating in the research project are applying the results of the labyrinth studies for the stability analysis of their machines. The magnitudes of labyrinth excitation constants to be expected are widely different depending on the operational boundary conditions of the seal. The utilization of results from the investigations of this research on similar labyrinth designs is shown in the calculation of fig. 13. For short labyrinth designs with few whirling chambers, the preswirl related lateral forces dominate, whereas the speed influence cannot be neglected with growing labyrinth length.

Stability calculations have been performed for rotors with different damping characteristics (damping reserves) to receive statements about the influence of the lateral forces in seals on the vibration behavior of centrifugal compressors. The effect of the labyrinth forces on the vibration behaviour of centrifugal compressor is shown in figure 14. For demonstration purpose two different rotors (Rotor 1 and Rotor 2) have been investigated by "Mannesmann-DEMAG". They basically differ by their shaft stiffness. Compared with rotor 1, rotor 2 has two additional impellers, a larger bearing span and slightly smaller shaft diameters underneath the impeller hubs. Consequently the first "critical speed" of rotor 1 is considerably higher than of rotor 2. The operating speed is supposed to be 12 000 rpm for both rotors resulting in critical speed ratios $n_B/n_{K1} = 1.7$ for Rotor 1 and 2.7 for Rotor 2. For each rotor (1 and 2) two different impeller arrangements A ("in line") and B ("back to back") have been analysed in order to show the influence of the attack location (Pos.x) on the aerodynamic excitation. At version A the excitation acts close to the bearing, at version B in the middle of the rotor. The attack position x represents a long labyrinth taking a high differential pressure which is typical for a thrust balance drum. For simplification only at this location an aerodynamic lateral force has been taken into account whereby only the substantial Q-component was considered (R-component neglected). The influences of the different impeller seals, where large entry swirl components arise, are also neglected.

In fig. 14 the attenuation factor of the rotor-bearing system is plotted against the rotor speed. The solid lines represent the system damping without aerodynamic excitation. The dotted curves show the effect resulting from labyrinth forces with various intensities. The diminution of the system damping increases with increasing labyrinth force coefficients K_Q . In particular this is the case for the very flexible rotor 2 (version B, force acting in the middle), where the damping becomes "negative" before the operating speed range is reached. Below the threshold point ($u/\omega_K = 0$) the rotor runs strongly unstable, vibrating with large amplitudes and defined frequencies (not shown in fig.14) which are not synchronous with the rotor speed.

For rotor 1 the damping characteristics for a further eigenvalue (x-branch) of the rotor-bearing system have been plotted in addition to the determining y-branch. For this eigenvalue (which belongs to a motion dominantly directed in the x-plane) the damping factors become larger for increasing K_Q -values, but this has no effect on the stability, which is governed by the y-branches.

An important conclusion can be drawn from the examples given: The analytical results indicate that also with multistage hp-centrifugal compressors having a very flexible rotor, instability can be avoided if appropriate measures will be taken in order to minimize (or even eliminate) the trouble-some Q-forces in labyrinths.

Seeing that look-through labyrinths with few sealing strips are frequently used for impeller seals, it is possible to assume comparable lateral force spring constants in the range of 1 to 10 N/ μ m. also in the interlocking labyrinths of a steam turbine. The calculations of a turbine maker for the high-pressure element of a 600 MW steam turbine plant has shown that the speed-related components of the dummy piston are responsible for a decrease in stability of the hp-rotor by about 3%. The negative restoring forces tend to reduce the natural frequencies of the individual sections of the turbo generator. Regarding the high-pressure section, the reduction in natural frequency for the two directions amounted to about 3.3-4.4%, whereas these effects were reduced for the IP section to about 1-2%.

CONCLUDING REMARKS

The presented labyrinth investigations confirm that the lateral force component resulting out of an unsymmetrical pressure distribution in eccentric gaps of labyrinth seals, acting at a right angle to the rotor deflection plane, represents a vibration exciting force, which has to be accounted for in rotor dynamics. The utilisation of the results shows the influences on the vibration behavior of high loaded turbomachines. A knowledge of the labyrinth spring constants permits a more accurate stability analysis. This makes it possible for any critical operational conditions to be detected already during the design stage of the machine.

To reduce the lateral force sensitivity of labyrinth seals, several possibilities are at hand. Their aim has to be to eliminate the circumferential flow in the chambers of the seal. Both effects - entry swirl and shaft rotation - induce circumferential components in the chambers and are therefore dangerous for the stability of the rotor. Two possibilities to avoid the exciting lateral forces shall be indicated. By a suitable change of the entry swirl of the flow ahead of the first seal tip in opposite direction of the sense of rotation of the shaft, a seal free of lateral forces can be achieved (figure 15, $u_w = -112$ m/s).

For short impeller seals, some swirl webs in front of the first fin at the periphery of the seal are sufficient to reduce the preswirl and therefore the lateral force sensitivity (fig.16). The influence of the speed related components of the lateral force, which will develop themselves within the seal, is minor with a small number of chambers.

LIST OF SYMBOLS

- International System of Units (SI) -

A	mean clearance area	μ	flow coefficient
c	flow velocity	ϵ	relative eccentricity ($\epsilon=e/\Delta r$)
E	flow index	ρ	density
e	rotor eccentricity	ϕ	peripheral angle
F_B	reference force		
h	height of space between sealing strips	<u>Subscript</u>	
K	spring constant	o	in front of labyrinth
k	ratio factor	a	behind labyrinth
m	number of spaces between sealing strips	ax	axial direction
\dot{m}	mass flow	ges	sum
p	pressure	i	labyrinth
Q	lateral force	Q	lateral force
R	restoring force	R	restoring force
r	rotor radius	u	peripheral direction
Δr	mean clearance width	w	shaft rotation
t	labyrinth pitch		
u_w	peripheral velocity	<u>Superscript</u>	
v	specific volume	*	related value
z	number of sealing strips	-	mean value

REFERENCES

1. Stodola, A.: Dampf- und Gasturbinen. Springer Verlag Berlin, 1924.
2. Greathead, S.H. and Bastow, P.: Investigations into Load Dependend Vibrations of the High Pressure Rotor on Large Turbo-Generators. Proc.Instn.Mech.Engrs., C 220/1976, pp. 279-285.
3. Thomas, H.J.: Unstable Oscillations of Turbine Rotors Due to Steam Leakage in the Clearances of the Sealing Glands and the Buckets. Bulletin Scientifique, A.J.M. 71, 1958, pp. 1039-1063.
4. Pollmann, E.: Stabilität einer in Gleitlagern rotierenden Welle mit Spalt-erregung. Fortschrittsbericht VDI-Z. Reihe 1, Nr. 15, 1969.
5. Alford, J.S.: Protecting Turbomachinery from Self-Exited Rotor Whirl. Transactions ASME, J. of Eng. f. Power, October 1965, pp. 333-344.
6. Spurk, J.H. and Keiper, R.: Selbsterregte Schwingungen bei Turbomaschinen infolge der Labyrinthströmung. Ingenieur-Archiv 43, 1974, pp. 127-135.

7. Wright, D.V: Air Model Test of Labyrinth Seal Forces on a Whirling Rotor. ASME Gas Turbine Div., Winter Annual Meeting 1977, pp. 61-73.
8. Kostyuk, A.G.: A Theoretical Analysis of the Aerodynamic Forces in the Labyrinth Glands of Turbomachines. Teploenergetika, 19(11) 1972, pp. 29-33.
9. Rosenberg, C.S., Orlik, W.G. and Marshenko, U.A.: Untersuchung aerodynamischer Querkräfte in den Labyrinthdichtungen bei Wellenexzentrizität. Energomashinostrojenie, No. 8, 1974, pp. 15-17.
10. Urlichs, K.: Durch Spaltströmungen hervorgerufene Querkräfte an den Läufern thermischer Turbomaschinen. Dissertation TU of Munich, 1975.
11. Kostyuk, A.G. and Kirjuchin, A.V.: Eigenschwingungen und Stabilität von Turbinenläufern in den Gleitlagern unter Berücksichtigung nichtkonservativer dynamischer Kräfte. Teploenergetika 25(9) 1978, pp. 14-19.
12. Linnemann, H. and Wettmann, K.: Laufstabilität thermischer Turbomaschinen. BBC-Nachrichten, Vol. 12, 1973, pp. 396-401.
13. Thomas, H.J.: Zur Laufstabilität einfacher Rotoren, besonders bei Spalterregung. Konstruktion 30(9) 1978, pp. 339-344.
14. Aicher, W., Jenny, R. and Roduner, H.: Untersuchungen an Turbokompressoren: Rotorschwingungen, Schaufelschwingungen, Versuche mit schweren Gasen. Techn. Rundschau Sulzer, Vol. 60, Forsch. Heft 1978, pp. 11-18.
15. Benckert, H. and Wachter, J.: Studies on Vibrations Stimulated by Lateral Forces in Sealing Gaps. AGARD-CP-237, 1978, pp. 9.1-9.11.
16. Pollmann, E., Schwerdtfeger, H. and Termühlen, H.: Flow Excited Vibrations in High-Pressure Turbines (Steam Whirl). ASME Gas Turbine Div., Winter Annual Meeting 1977, pp. 75-87.
17. Benckert, H. and Wachter, J.: Investigations on the Mass Flow and the Flow Induced Forces in Contactless Seals of Turbomachines. Proceedings of the 6th Conference on Fluid Machinery, Budapest 1979, S. 57-66.
18. Benckert, H.: Spaltströmungen. Forschungsberichte Forschungsvereinigung Verbrennungskraftmaschinen Frankfurt/Main, H. 253, 1978.

APPENDIX

The appendix will give some informations about the studies on labyrinth seals furthermore done after writing the paper. The figures A1 - A9 are abridged from a publication of the institute (ref. 19).

The lateral forces due to the swirl-type entry flow of the labyrinth (rotor stationary, $u_w=0$) has been investigated separately for different look-through labyrinth configurations (fig. A1 and A2). In addition to the paper the influence of the labyrinth pitch could be proved also for this type of labyrinth. Figure A2 shows the results for the relative lateral force spring coefficients due to the entry swirl of the flow. The given geometry-factor k_G is related to the flow coefficient μ' , which is defined especially for look-through labyrinths:

$$\mu' = \mu k_{\bar{u}} \quad (9)$$

According to the paper, the factor μ in equation 7 and 8 corresponds for a look-through labyrinth to the product μ' (eq. 9). The factor $k_{\bar{u}}$ describes the different behaviour of the mass flow for comparable look-through and interlocking labyrinths. The effect of the radius of the shaft on the lateral forces differs nearly 30% from a quadratic relationship. In look-through labyrinths the "Spiral Flow Effect" is dominant for the exciting forces. The relationship for \bar{K}_Q^* and the dimensioned lateral force spring coefficient K_Q are plotted in figure A2 ($\Delta p_{st} = p_o - p_a \approx \Delta p_{ges}$). If the factor μ (in eq. 9) of the seal is not known, it is possible to estimate the lateral force spring coefficients for look-through labyrinths of usual design by using the following equation:

$$K_Q = k_G r^2 \sqrt{0,5 \varphi_o c_{uo}^2 \Delta p_{st}} / h \quad (10)$$

The lateral forces in labyrinths due to the shaft rotation are a function of the peripheral flow in the spaces between the sealing strips. In addition to the paper figure A3 shows in function of the entry swirl c_{uo} two areas for the circumferential velocities of the flow in the eddy chambers. The dominant influence of the constant c_{um} -area in long labyrinths can be demonstrated by figure A4. The lateral forces result mostly from the eddy chambers $m > 6$. Figure A5 was obtained evaluating the dimensionless force/displacement characteristics of the constant area for different running conditions. The stated function of the straight line in the figure A5 confirms equation 5. Independent from the number of eddy chambers ($m = 17$ and 23) the product " $\varphi_m c_{um}^2$ " is a criterion for the lateral forces in multi-chamber labyrinth seals (subscript m: mean value in the constant area).

In addition to the experimental studies a theoretical model has been developed for the calculation of the speed induced forces in labyrinth seals (ref. 19). In the first step of the computation the peripheral velocity of the flow is calculated in each eddy chamber of the seal. Measured and calculated c_u -velocities have been compared and the accuracy of the model could be proved. Based on these results the flow induced forces of each chamber are calculated. Figure A6 shows

Reference 19: Benckert, H.: Strömungsbedingte Federkennwerte in Labyrinthdichtungen. Mitteilung des Institutes für Thermische Strömungsmaschinen, Universität Stuttgart, Nr.8, 1980, 159 pages, 82 figures

computed results, which are comparable with the experimental lateral spring constants shown in figure A4. The influence of the density of the fluid is demonstrated in figure A7 for the same type of labyrinth. Using the theoretical model for the constant area of the c_u -components of the flow in the labyrinth, the following relationship can be stated (m_n : number of eddy chambers in this area):

$$K_Q = \pi m_n r^2 \rho_m [(k_1 - k_2) c_{um}^2 + k_2 c_{um} u_w] / h^2 \quad (11)$$

The factors $k_{1,2}$ correspond to the mean coefficients of friction of the stator (k_1) and the rotor (k_2) in the eddy chambers.

Additionally to the figures 15 and 16 of the paper the figures A8 and A9 should point out the problems in reducing speed-related lateral forces by using special constructions of labyrinth seals.

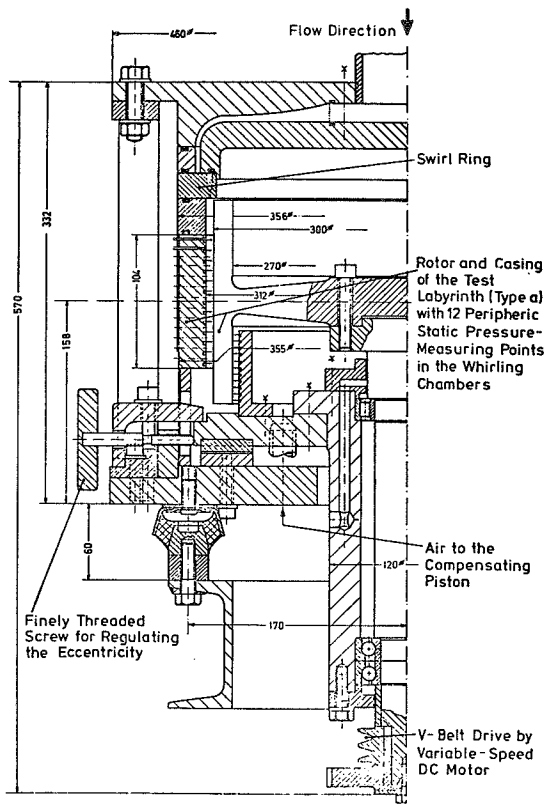

Fig. 1: Testing facility for labyrinths

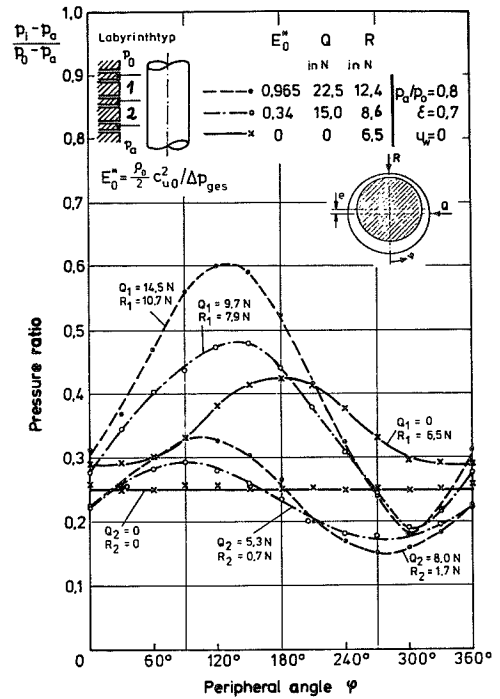

Fig. 2: Pressure distributions and forces in a half-labyrinth with eccentric rotor

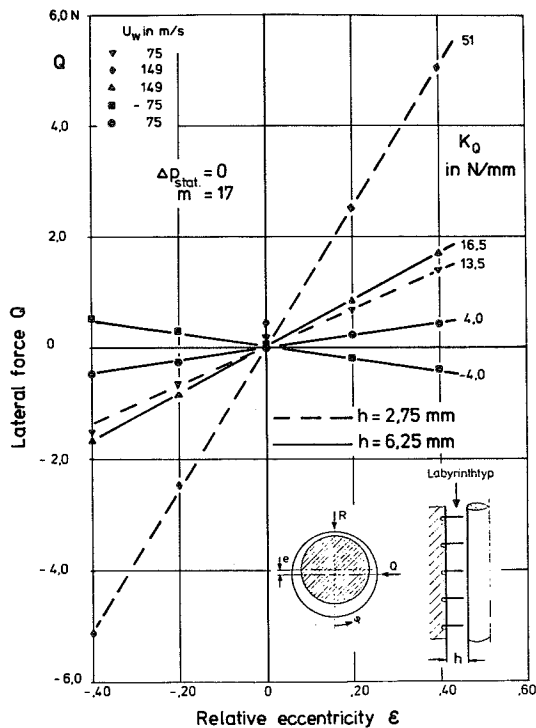

Fig. 3: Force characteristics due to height of chamber and shaft rotation without mass flow

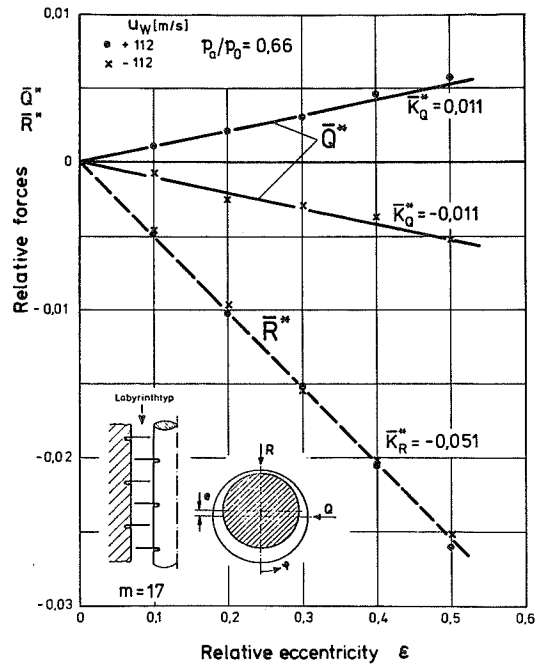

Fig. 4: Forces of an eccentric labyrinth due to reverse of shaft rotation

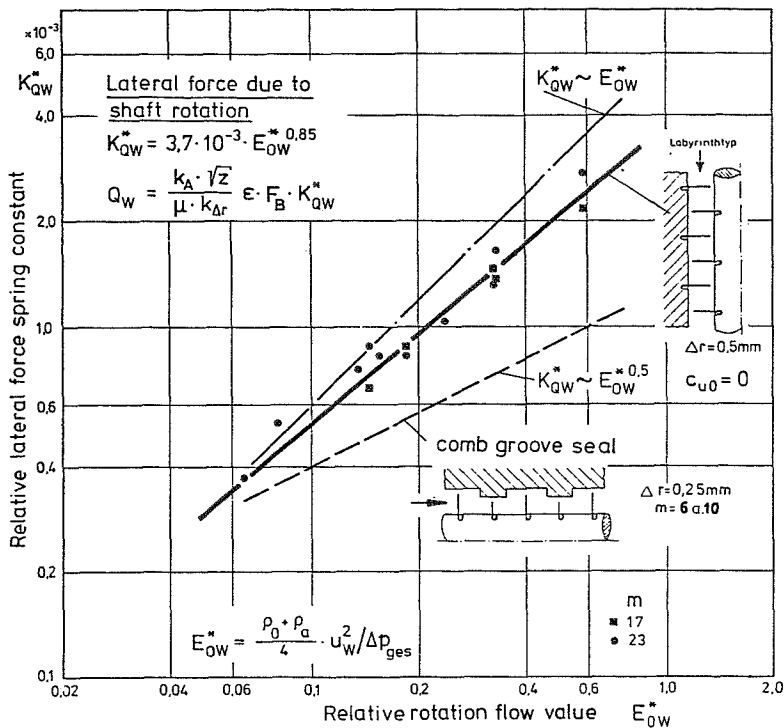

Fig. 5: Lateral force spring coefficients as function of the relative rotation flow value

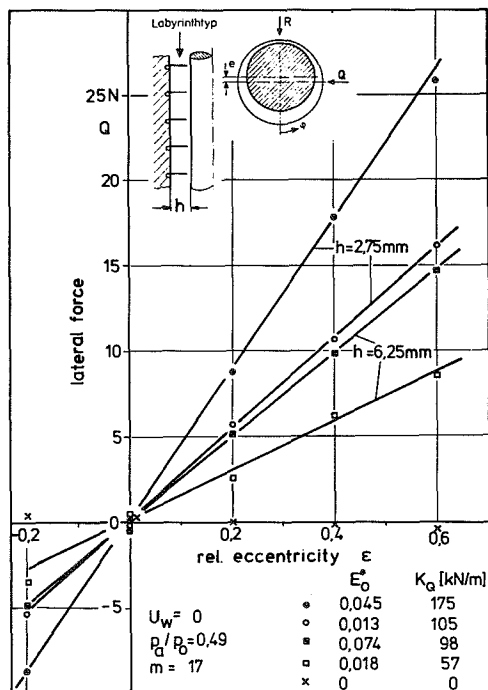

Fig. 6: Influence of height of chambers on the lateral force due to entry swirl

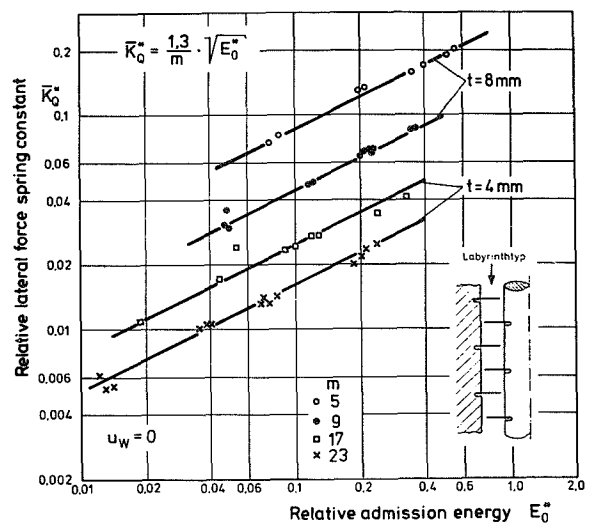

Fig. 7: Lateral force spring constants as function of the relative admission energy of the flow

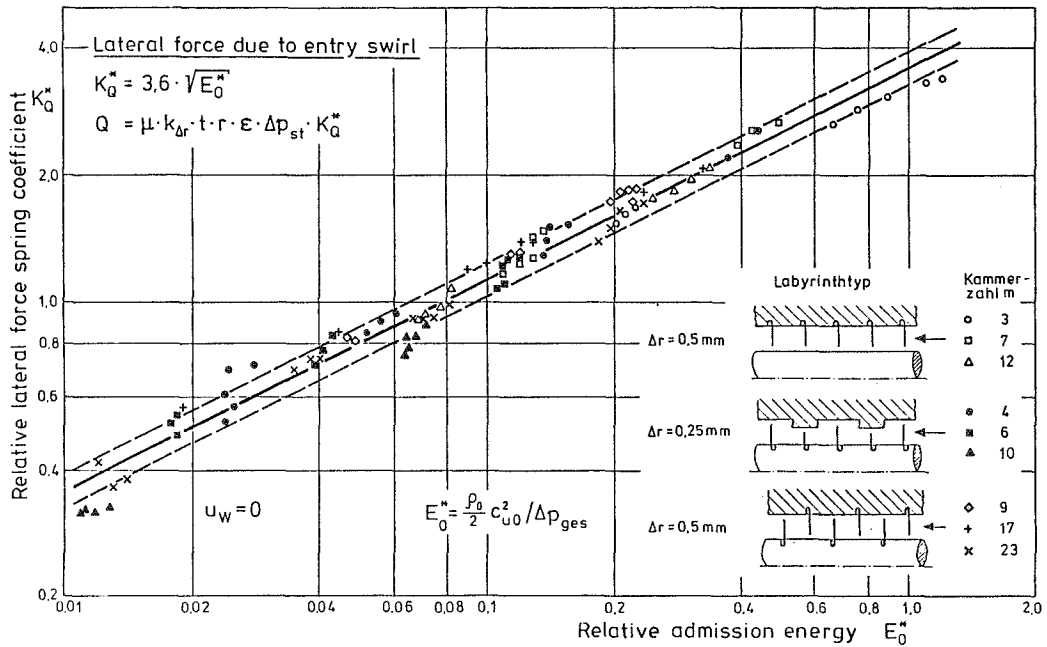

Fig. 8: Lateral force spring coefficients for different labyrinth patterns as function of the relative admission energy of the flow

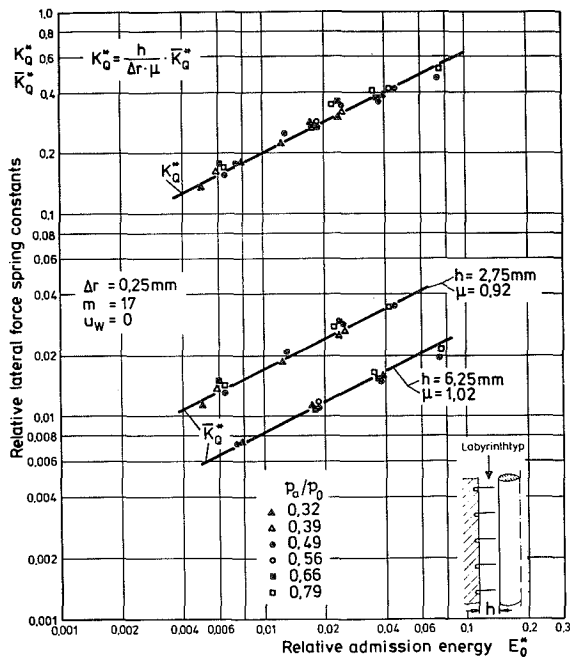

Fig. 9: Influence of height of chamber on the lateral force spring coefficients

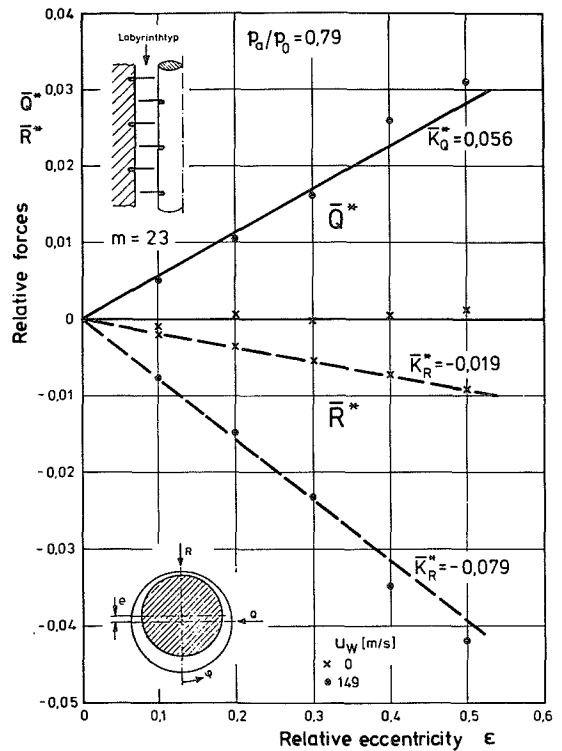

Fig. 10: Relative forces of an eccentric labyrinth without entry swirl

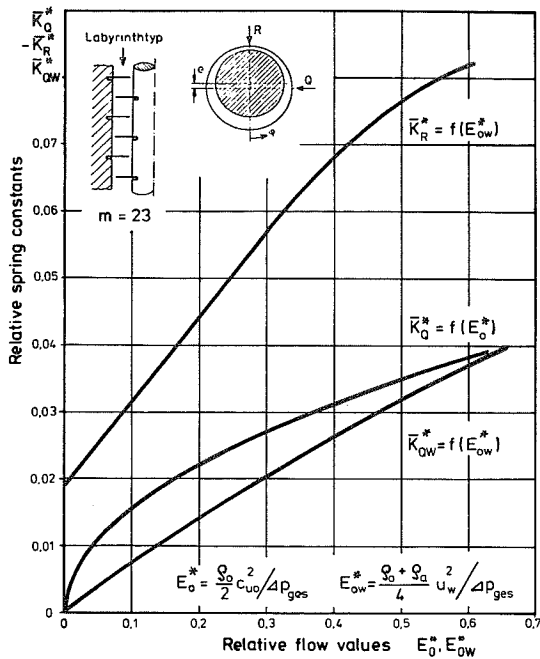

Fig. 11: Flow induced spring coefficients for the lateral and restoring force of a labyrinth as function of the relative characteristic flow values

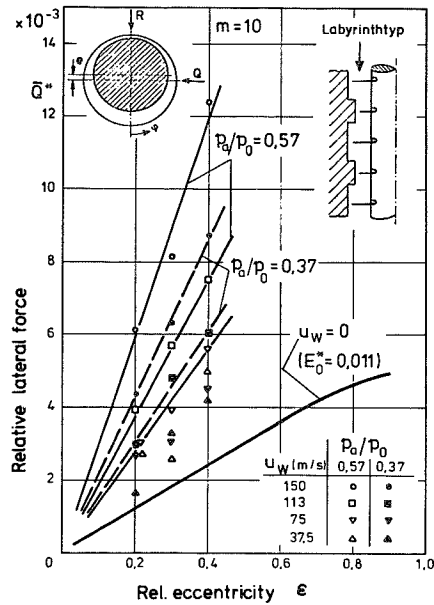

Fig. 12: Influence of rotor speed and pressure ratio on the lateral forces with entry swirl of the flow

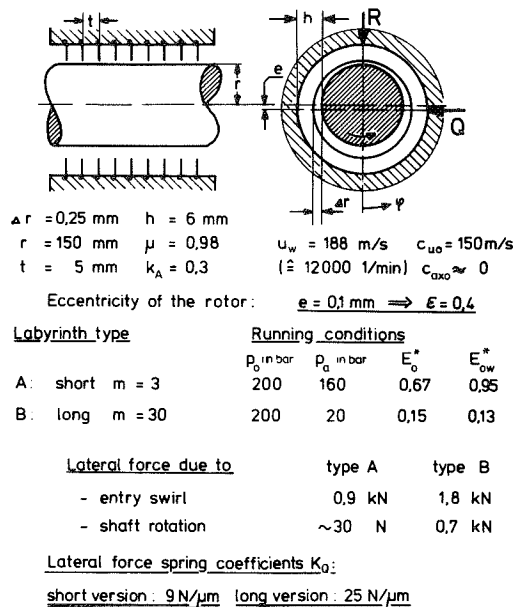

Fig. 13: Estimation of lateral force constants for two labyrinths

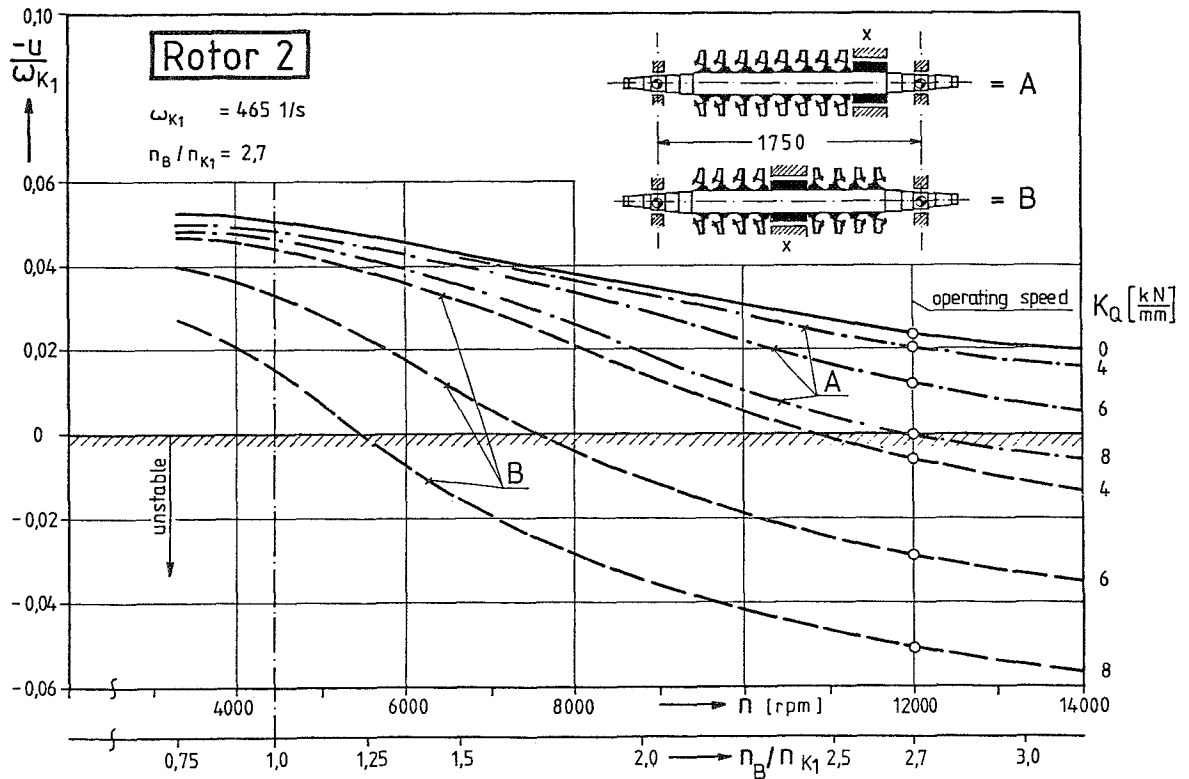
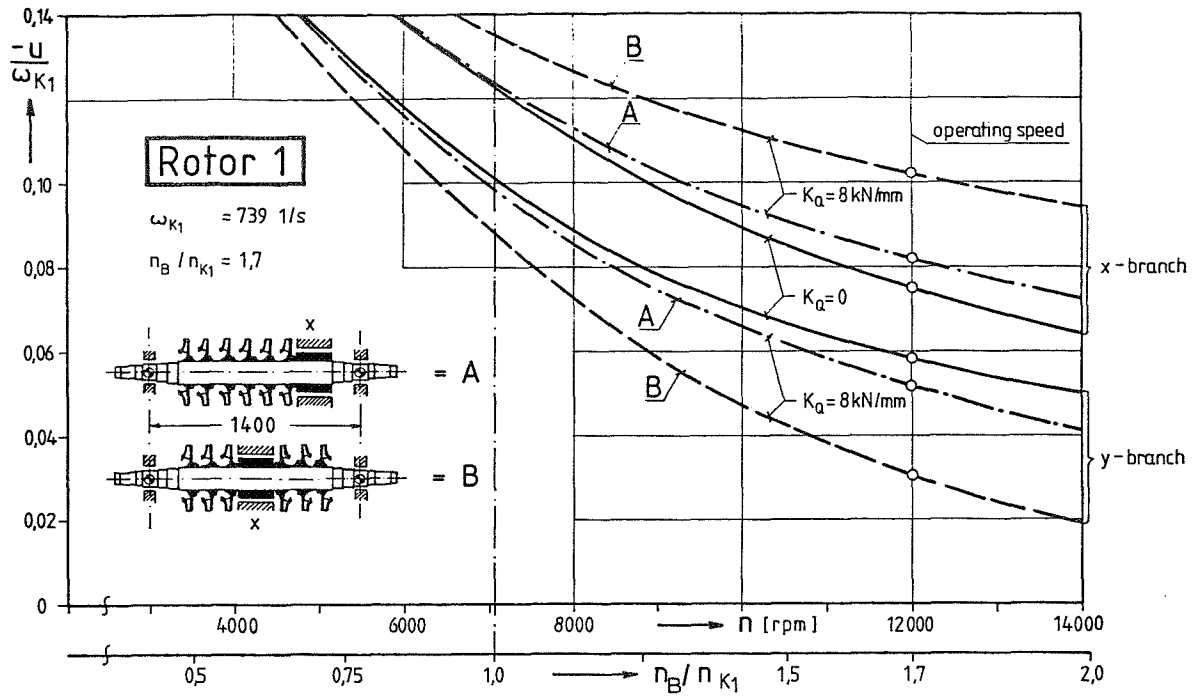

Fig. 14: Influence of lateral labyrinth forces on the damping behaviour for two rotors with different shaft stiffness (Bearings: tilting pad; $n=5$; $B/D=0,5$; $m=2,5$; $\Psi=1,5 \cdot 10^{-3}$)
 - calculated by Mannesmann-DEMAG -

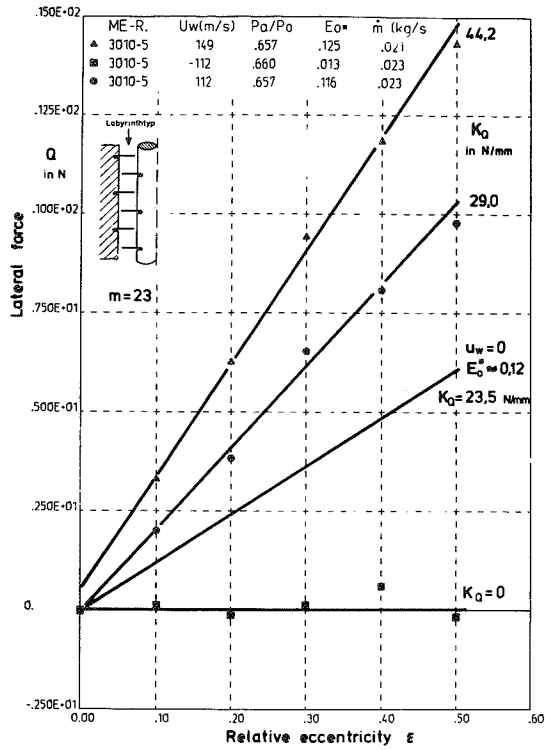

Fig. 15: Lateral force characteristics due to shaft rotation with entry swirl of the flow

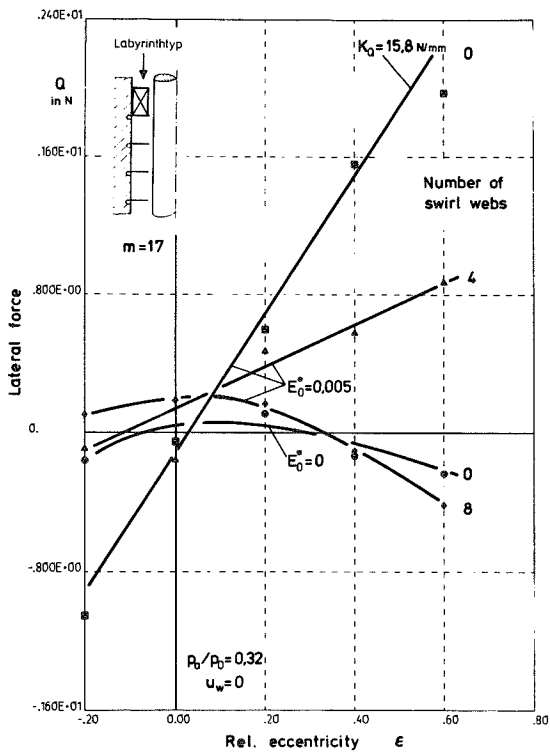

Fig. 16: Reduction of lateral forces by using swirl webs in front of the labyrinth

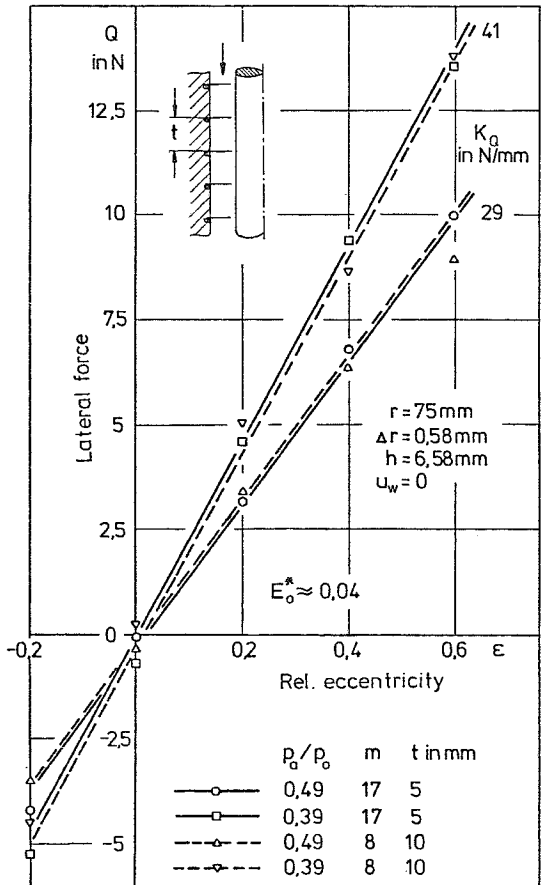

Fig. A1: Influence of the labyrinth-pitch on the lateral forces due to flow with entry swirl.

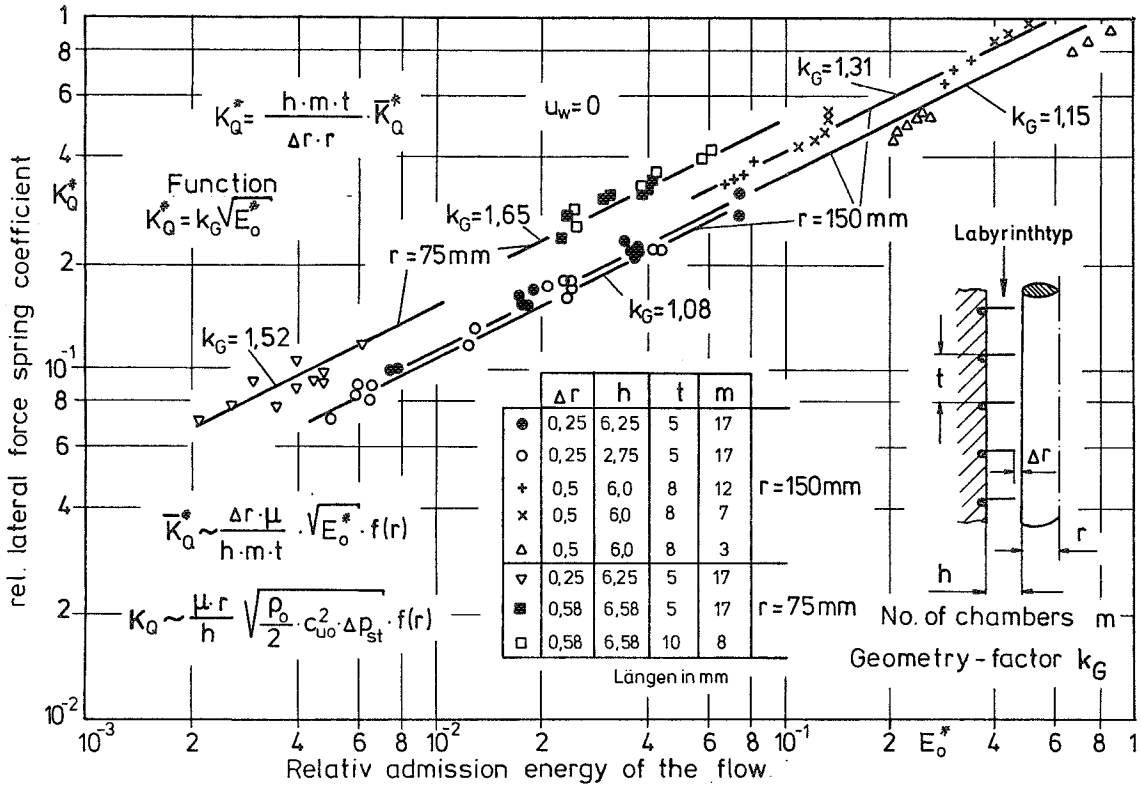

Fig. A2: Lateral force spring coefficients of look-through labyrinths with swirl type entry flow.

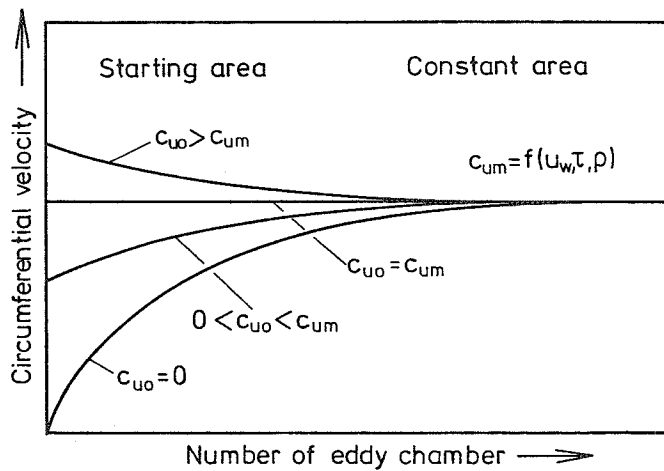

Fig. A3: Definition of two labyrinth areas for the circumferential velocity of the flow.

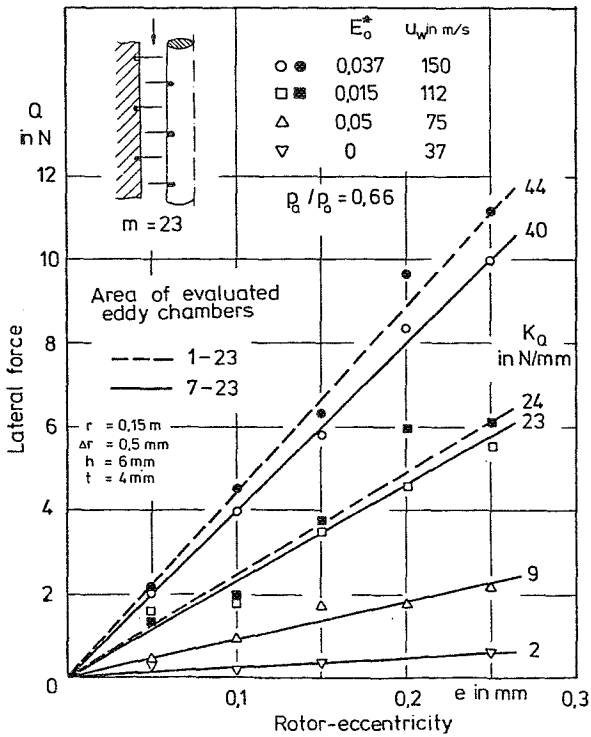

Fig. A4: Speed induced lateral forces of the total labyrinth and the area with constant peripheral flow components.

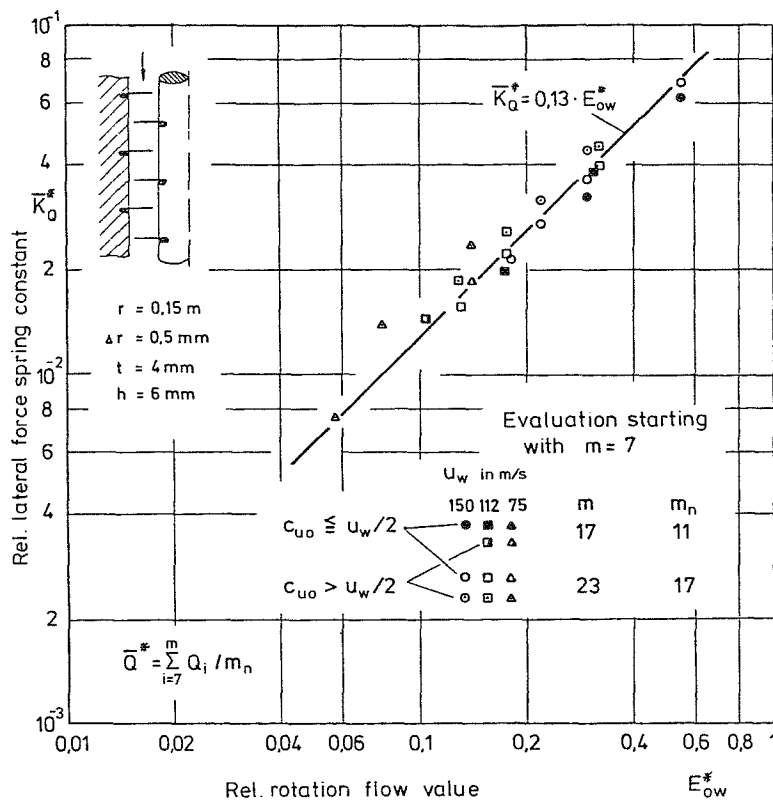

Fig. A5: Lateral force spring coefficients without evaluation of the first six eddy chambers (shaft rotation and entry swirl).

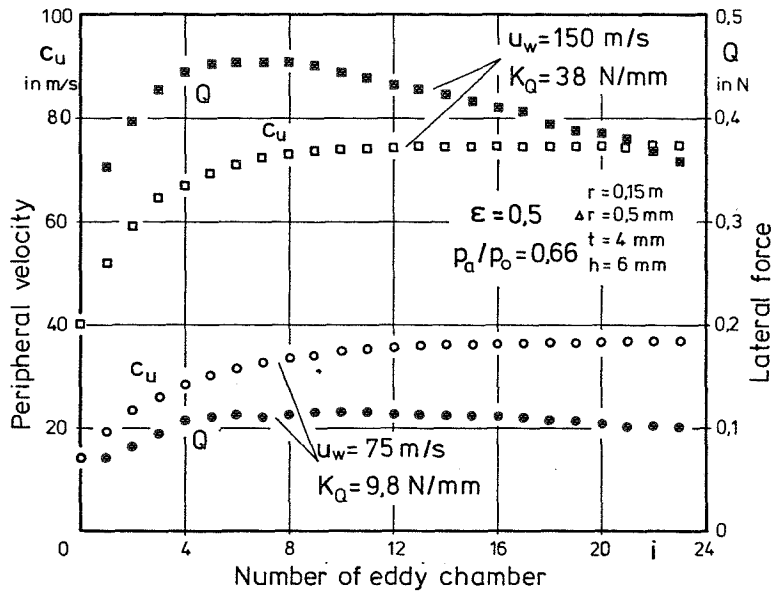

Fig. A6: Calculated distributions of the circumferential velocity of the flow and the lateral forces due to shaft rotation and entry swirl in an interlocking labyrinth seal.

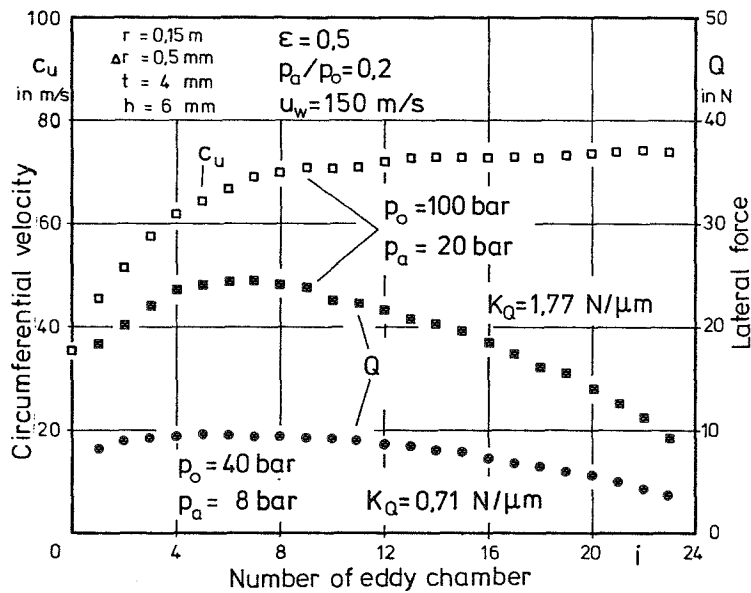

Fig. A7: Influence of density of the fluid on the peripheral velocity of the flow and on the lateral forces in an interlocking labyrinth (Calculation).

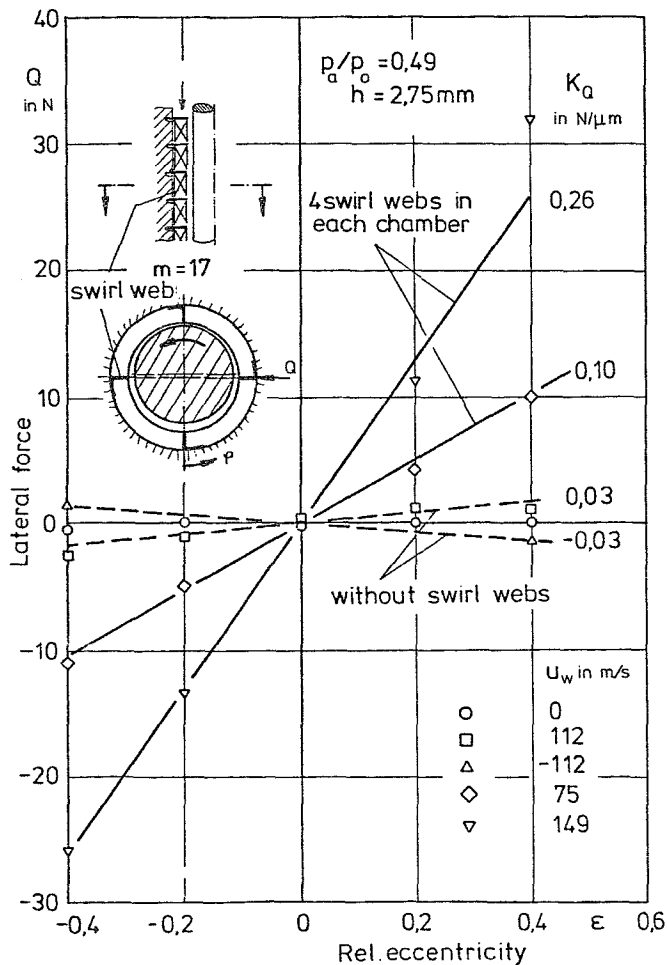

Fig. A8: Speed induced lateral forces by using swirl webs in each eddy chamber of the labyrinth.

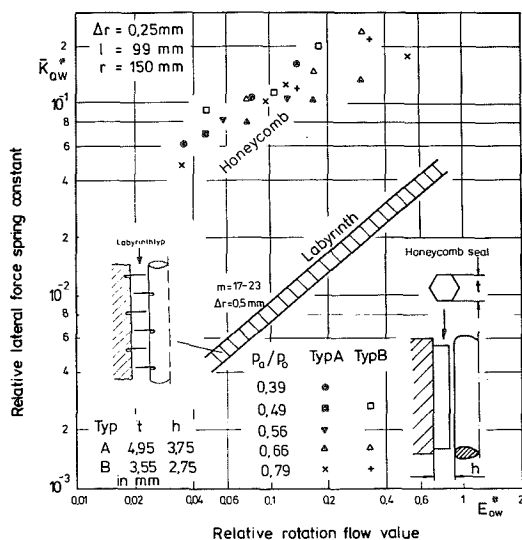

Fig. A9: Lateral force spring coefficients as function of the relative rotation flow value for two honeycomb seals.