

Formation of Chlorinated Derivatives of Bisphenol A in Waste Paper Recycling Plants and Their Estrogenic Activities

Hitoshi Fukazawa,^a Masayuki Watanabe,^a Fujio Shiraishi,^b Hiroaki Shiraishi,^b Tatsushi Shiozawa,^c Hidetsuru Matsushita,^a and Yoshiyasu Terao^{*,c}

^aShizuoka Institute of Environment and Hygiene, 4-27-2 Kitaando, Shizuoka 420-8637, Japan, ^bNational Institute for Environment Studies, 16-2 Onogawa, Tsukuba, Ibaraki 305-0053, Japan, and ^cInstitute for Environmental Sciences, University of Shizuoka, 52-1 Yada, Shizuoka 422-8526, Japan

(Received January 9, 2002; Accepted March 4, 2002)

High concentrations of bisphenol A were detected in the effluent from several pulping processes for waste paper containing thermal paper and/or other printed paper. Chlorinated derivatives of bisphenol A were found to be formed by its reaction with a low concentration of chlorine in the effluent from the bleaching process using sodium hypochlorite. Poly-chlorinated derivatives were mainly detected in the final effluents from two plants because they were not biodegraded in the water recycling process by treatment with activated sludge. The estrogenic activities of bisphenol A and its chlorinated derivatives were evaluated by an agonist assay using the yeast two-hybrid system with and without a metabolic activation test using rat liver S9. All of the chlorinated derivatives tested showed more potent activity than bisphenol A without S9. The activity of 3,3'-dichlorinated BPA was 38-fold stronger than that of bisphenol A. The activities of these compounds were almost eliminated upon treatment with S9.

Key words — bisphenol A, chlorinated bisphenol A, waste paper recycling, chlorine bleaching process, estrogenic activity, yeast two-hybrid assay

INTRODUCTION

Bisphenol A, 2,2-bis(4-hydroxyphenyl)propane (BPA), has weak acute toxicity toward aquatic organisms; LC₅₀ or EC₅₀ levels for fish and invertebrates range from 1.1 to 10 mg/l.¹⁾ Bisphenol A has also been reported to interact with estrogen receptors.²⁻⁴⁾ Currently, there is considerable interest in potential effects on fish populations with a view to developing regulatory criteria.

Bisphenol A is used in the production of polycarbonate and epoxy resins, flame retardants, and other specialty products. Final products include adhesives, protective coatings, powder paints, building materials, compact disks, thermal paper and electronic parts. In addition, bisphenol A is used in the paper industry, where it is used mainly as a developer in dyes for thermal papers. Therefore, we thought that bisphenol A might be released into wastewater from recycling plants that processed such

paper products. On the other hand, we previously demonstrated that bisphenol A readily reacted with sodium hypochlorite, which is used as a bleaching agent in paper factories, to give chlorinated derivatives of bisphenol A. Further investigation revealed that such derivatives contaminated the final effluent from waste paper recycling plants.⁵⁾ Based on these findings, we shifted our attention to clarifying of the process by which these compounds are released into the effluent and the toxicity of chlorinated derivatives. Figure 1 shows the chemical structures of bisphenol A and its chlorinated derivatives.

In the present study, we quantitatively analyzed bisphenol A and chlorinated bisphenol A in the effluent from several processes of paper recycling plants. Furthermore, we evaluated the estrogenic activities of the chlorinated derivatives of bisphenol A with an estrogenicity assay system for agonist activity using the yeast two-hybrid system.

MATERIALS AND METHODS

Bisphenol A and bisphenol A-d₁₆ were purchased from Kanto Chemical Co., Inc., Japan. Chlorinated

*To whom correspondence should be addressed: Institute for Environmental Sciences, University of Shizuoka, 52-1 Yada, Shizuoka 422-8526, Japan. Tel. & Fax: +81-54-264-5788; E-mail: terao@u-shizuoka-ken.ac.jp

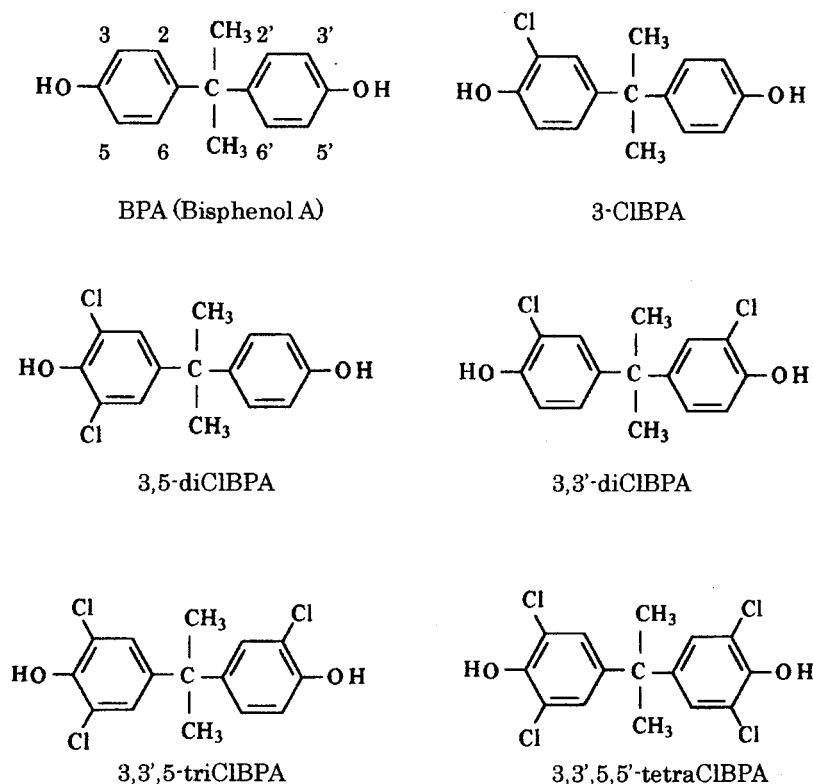

Fig. 1. Chemical Structures of Bisphenol A and Its Chlorinated Derivatives

bisphenol A [3-CIBPA: 2-(3-chloro-4-hydroxyphenyl)-2-(4-hydroxyphenyl)propane, 3,5-diCIBPA: 2-(3,5-dichloro-4-hydroxyphenyl)-2-(4-hydroxyphenyl)propane, 3,3'-diCIBPA: 2,2-bis(3-chloro-4-hydroxyphenyl)propane, 3,3',5-triCIBPA: 2-(3,5-dichloro-4-hydroxyphenyl)-2-(3-chloro-4-hydroxyphenyl)propane, 3,3',5,5'-tetraCIBPA: 2,2-bis(3,5-dichloro-4-hydroxyphenyl)propane] were synthesized and purified as described previously.⁵ *N,O*-Bis(trimethylsilyl)trifluoroacetamide (BSTFA) of GC grade was obtained from Wako Pure Chemicals Industry Ltd., Japan. All solvents used were of pesticide analysis grade and other chemicals were of chemical grade. Water was treated by a Milli-Q Water Purification System after distillation and then purified with an activated carbon column (Active carbon beads-L 20/30 mesh, GL Science Inc., Japan).

Recombinant yeast with the estrogen receptor ER α and the coactivator TIF2 was provided by Nishikawa.⁶ Modified SD (MSD) medium was prepared by changing to 0.86% dextrose. An AuroraTM GAL-XE kit (contain chemiluminescent substrate, reaction buffer and accelerator) was purchased from ICN Pharm. Inc. Zymolyase 20T was purchased from Seikagaku Co., Tokyo, Japan. Rat liver S9 was purchased from Kikkoman Co., Tokyo, Japan.

GC/MS Apparatus and Operating Conditions

— Gas chromatography/mass spectrometry (GC/MS) was performed with an HP 5890 II gas chromatograph equipped with an HP 5971A mass spectrometer (Hewlett Packard, U.S.A.). The injection temperature was 250°C and the injection mode was splitless. The carrier gas was helium and the column head pressure was 7 psi. An HP-5 Trace Analysis capillary column (30 m \times 0.25 mm i.d., 0.1 μ m d_t) was used. The oven temperature was initially 100°C, and then raised to 270°C at a rate of 15°C/min, and finally held at that temperature for 6 min. The MS transfer line temperature was 290°C. MS measurement was performed in the selected ion monitoring (SIM) mode for a quantitative analysis. Bisphenol A and its chlorinated derivatives were detected after trimethylsilylation with BSTFA, and the ions monitored were as follows: BPA, m/z 357, 372, 207; BPA- d_{16} , m/z 368, 386, 217; 3-CIBPA, m/z 392, 393, 406; 3,5- and 3,3'-diCIBPA, m/z 425, 427, 440; 3,3',5-triCIBPA, m/z 459, 461, 474; 3,3',5,5'-tetraCIBPA, m/z 495, 493, 510.

Sample Preparation for the Determination of Bisphenol A and Its Chlorinated Derivatives

— One hundred milliliters of an aqueous sample was transferred to a separatory funnel and acidified with

hydrochloric acid ($\text{pH} < 4$). The solution was extracted twice with 20 ml of dichloromethane by shaking for 10 min. The emulsion was further extracted twice with 5 ml of dichloromethane by shaking for 10 min. The dichloromethane layers were combined and dried over anhydrous sodium sulfate. The extract was then concentrated on a rotary evaporator to about 1 ml and was further concentrated to 0.3 ml under a nitrogen stream. After the addition of 200 μl of BSTFA solution, the sample solution was allowed to stand for 30 min to form the bis(trimethylsilyl) ethers. The reaction solution was concentrated again to 0.3 ml under a nitrogen stream. The sample solution diluted up to 1 ml with dichloromethane was subjected to GC/MS (SIM) analysis.

Estrogenic Activity of Bisphenol A and its Chlorinated Derivatives — The agonist activities for estrogen receptor of bisphenol A and its chlorinated derivatives were evaluated by a rapid and simple operational estrogenicity assay system using the yeast two-hybrid system.⁷⁾

Sample solutions were prepared by dissolving the chemicals in dimethylsulfoxide (DMSO) at a concentration of 2 mM. A solution (20 μl) was prepared with MSD medium (480 μl) for direct assay without S9. On the other hand, a solution (20 μl) prepared with S9 mix (S9 concentration of 4.8%, 480 μl) was treated at 37°C for 1 hr for metabolic activation assay. The yeast cells were preincubated overnight at 30°C in MSD medium lacking tryptophan and leucine. MSD medium (60 μl) was placed in each well of a 96-well of microplate. Next, 60 μl of sample treated with or without S9 was added in triplicate to the wells of the first column, and diluted. After the cell suspension (60 μl) was added to each well, the mixture was shaken with a vortex mixer and incubated for 4 hr at 30°C.

Eighty microliters of reaction solution [Lysis sol. (zymolyase 20T/Z buffer 2 mg/ml) + Aurora reaction buffer sol. (5 : 3)] was added to each well and incubated for 1 hr at 37°C. Supplementation with medium or cell suspension and dilution of sample were carried out using an automatic dilution and dispensing system (NSP-7000, NICHIRYO, Japan). Fifty microliters of light emission accelerator solution was added and the intensity of chemiluminescence by β -galactosidase was measured with a luminescencer-JNR (AB2100, ATTO, Japan). *Trans*-stilbene (0–10000 nM) and 17 β -estradiol (0–2000 pM) were used as positive control chemicals for the assay with and without S9.

Agonist activity was evaluated in terms of EC_{50} ,

which was defined as the concentration at which the ratio of the chemiluminescent signal of the sample to that of a blank control was 10.

RESULTS AND DISCUSSION

Determination of Bisphenol A and Chlorinated Bisphenol A in Final Effluents

Since wastewater from recycling contains various organic compounds, bisphenol A and its chlorinated derivatives were determined as bis(trimethylsilyl) ethers to avoid contamination and to improve their limits of detection. The characteristics of mass spectra of these derivatives have been described previously.⁵⁾ The recovery rate of BPA- d_{16} from final effluents ranged from 88 to 94% ($n = 4$) for a concentration of 5 $\mu\text{g/l}$.

We analyzed bisphenol A and its chlorinated derivatives in the final effluents from 20 paper manufacturing plants in Shizuoka prefecture, Japan. Table 1 shows the results together with the products, raw materials, bleaching agents and method of wastewater treatment in these plants.

Bisphenol A was detected in the final effluent, at concentrations from all of these plants ranging from 0.2 to 370 $\mu\text{g/l}$ (av. 59 $\mu\text{g/l}$). At two plants (Nos. 1 and 2), where only pulp was used as a raw material, bisphenol A was detected at a low level of between 0.2 and 0.4 $\mu\text{g/l}$. However, at the other plants, where waste papers were used, concentrations of bisphenol A became higher. The concentration of bisphenol A in the final effluent was affected by the waste paper being treated. It seems likely that treatment of printed paper and thermal paper increases the amount of bisphenol A released.

Production of Chlorinated Derivatives of Bisphenol A in the Bleaching Process

Chlorinated derivatives of bisphenol A were found in the final effluent at 8 plants at concentrations ranging from trace to 2.0 $\mu\text{g/l}$. Since sodium hypochlorite was used in the bleaching process in all of these plants, it is likely that the chlorination of bisphenol A involves sodium hypochlorite. However, it is unclear why poly-chlorinated derivatives were detected in preference to mono- or di-chlorinated derivatives at plants 14 and 15. To clarify this point, we further analyzed the effluent for each process in plant 15.

Figure 2 shows the manufacturing and wastewater treatment processes in plant 15. In this plant, the

Table 1. Concentration of Bisphenol A and Its Chlorinated Derivatives in the Final Effluents from 20 Paper Manufacturing Plants

Plant No.	Concentration of Bisphenol A and Its Chlorinated Derivatives ($\mu\text{g/l}$) ^{a)}						Main products ^{b)}	Raw materials ^{c)}	Bleaching agents ^{d)}	Wastewater treatment ^{e)}
	BPA	3-Cl-BPA	3,5-diCl-BPA	3,3'-diCl-BPA	3,3',5-triCl-BPA	3,3',5,5'-tetraCl-BPA				
1	0.2						To,Ti	Pu	nt	Fl
2	0.4						To,Ti	Pu	nt	Fl,Ac
3	0.4						Co,Wh,Wo	Pu,Ne,Co	H ₂ O ₂	Fl,Ac,Se
4	0.6						Bo	Ma,Co,Pu	nt	Fl
5	0.6						Wo	Pr	nt	Fl,Ac
6	1.3						To	Pr,	NaOCl	Fl,Se,Sp
7	1.5						Wh	Ca,Ne	nt	Fl
8	1.6						Ro	Ne,Ma,Li	nt	Fl
9	2.3						Wh	Pu,Ca,Ne	nt	Fl
10	7.8	0.3	0.4	tr			To	Pr,Mi	NaOCl	Se
11	13						Wo	Ne,Pr	H ₂ O ₂	Fl,Sp
12	39						To,Bo,Wo	Pu,Mi	H ₂ O ₂	Fl,Se
13	41	tr					To	Pr,Mi	NaOCl	Se
14	43	0.8	1.0	tr	1.2	1.4	To	Pr,Mi,Th	NaOCl	Se,Ac
15	63	0.5	0.4	0.5	0.9	1.3	To	Pr,Mi,Dr	NaOCl	Se,Ac
16	71						To,Ti	Pu,Pr,Dr,Mi	NaOCl	Se
17	119	2.0	tr	tr			To	Mi,Pr,Ct	NaOCl	Se
18	195	0.2					To,Ti	Pr,Mi	NaOCl	Se
19	202	tr					To	Mi,Pr,Dr	NaOCl	Se,Sp
20	370	0.3					To	Of,Mi,Dr	NaOCl	Fl,Sp
min.	0.2	tr	tr	tr	0.9	1.3				
max.	370	2.0	1.0	0.5	1.2	1.4				
ave.	59									

a) tr: < 0.2 $\mu\text{g/l}$. b) To: Toilet paper, Ti: Tissue paper, Co: Corrugated cardboards, Wh: White boards, Ro: Roofing materials, Wo: Woody paper. c) Pu: Pulp, Ne: Newspapers, Ma: Magazines, Pr: Printer's offcuts, Bo: Boards, Co: Corrugated cardboards, Of: Office records, Li: Linter, Ct: Coated papers, Dr: Milk and drink cartons, Mi: Mixed paper, Th: Thermal paper. d) nt: not used. e) Ac: Activated sludge, Se: Coagulating sedimentation, Sp: Sprinkle filtration, Fl: Pressure floatation.

effluent for each process was reused in a more polluting process to decrease the volume of wastewater. Therefore, each effluent was treated by coagulating sedimentation and/or activated sludge, and while some was discharged into the final effluent, the rest was recycled.

Table 2 shows the concentrations of bisphenol A and its chlorinated derivatives in the effluent for each process at plant 15. Bisphenol A was released from the pulping process (sampling sites S-1, S-2, S-3 and S-4, in Fig. 2) at higher concentrations from 196 to 10300 $\mu\text{g/l}$. Bisphenol A was detected at the highest concentration in the effluent from pulp-thickening process. This can be explained by the fact that the pulping was carried out under alkaline conditions, solubility of bisphenol A in aqueous solution increased consequently,⁸⁾ and the reuse of the effluent from this process resulted in the accumulation of resolved bisphenol A. In addition, if waste paper

is mixed with polycarbonate resins, bisphenol A may be released at a higher concentration into the effluent because such resins readily undergo hydrolysis under alkaline conditions to give bisphenol A.⁹⁾

In the sample water after washing of bleached pulp (sampling site S-5), bisphenol A and its chlorinated derivatives were detected at low concentrations. In this plant, deinked pulp was bleached using 12% sodium hypochlorite solution and the residual chlorine in the effluent from the washing of bleached pulp was controlled to maintain a low concentration, which was determined to range between 0.2 and 0.4 mg/l by the *ortho*-tolidine colorimetric method. Therefore, the chlorinated derivatives may have been generated by chlorination with a low concentration of residual chlorine from the washing of bleached pulp, during reuse of the effluent from this process.

In activated sludge treatment (sampling sites S-6

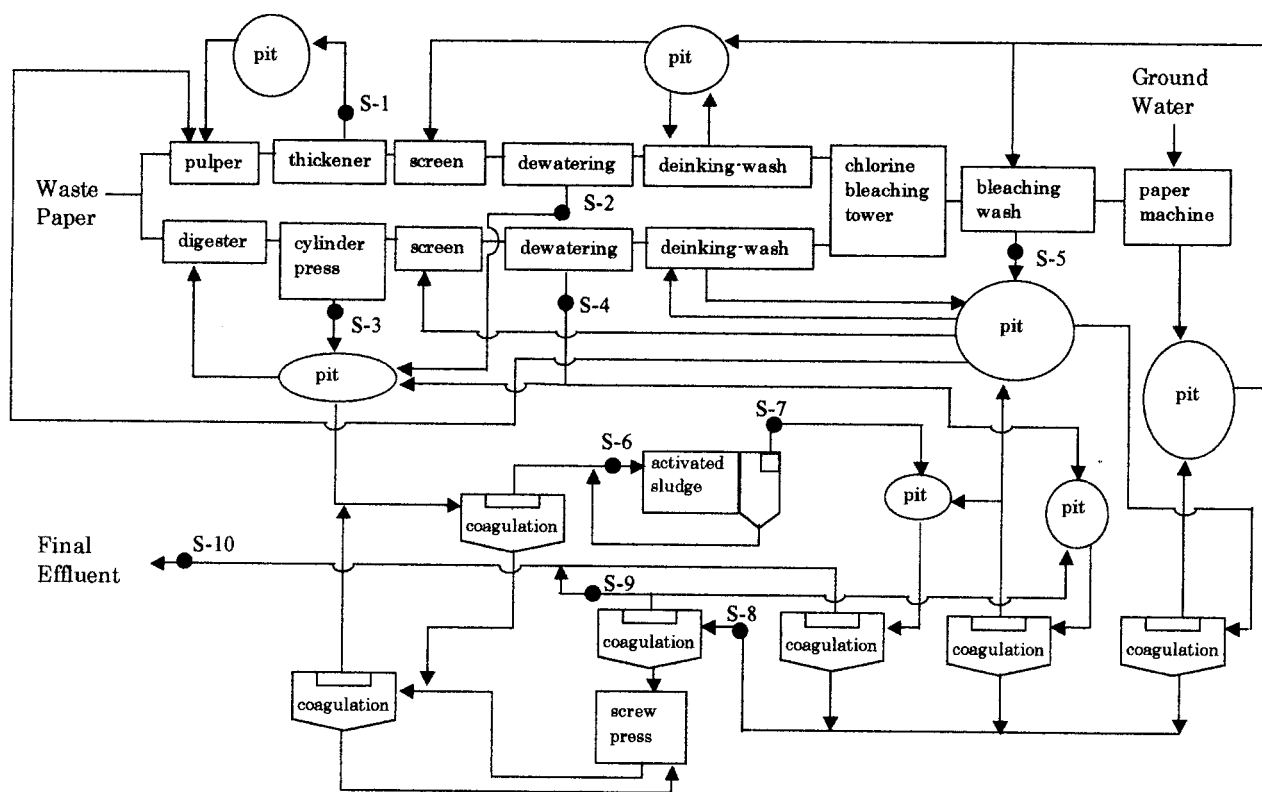

Fig. 2. Manufacturing and Wastewater Treatment Processes, and Sampling Sites at Plant 15

Table 2. Concentration of Bisphenol A and Its Chlorinated Derivatives in Process and Treatment Effluents at Plant 15

Sampling site ^{b)}	First measurement (8/31/99)							Second measurement (10/15/99)						
	pH	$(\mu\text{g/l})^{\text{a}}$						pH	$(\mu\text{g/l})^{\text{a}}$					
		BPA	3-Cl-BPA	3,5-diCl-BPA	3,3'-diCl-BPA	3,3',5-triCl-BPA	3,3',5,5'-tetraCl-BPA		BPA	3-Cl-BPA	3,5-diCl-BPA	3,3'-diCl-BPA	3,3',5-triCl-BPA	3,3',5,5'-tetraCl-BPA
S-1	> 11	10300	* ^{c)}	*	*	*	*	> 11	490	*	*	*	*	*
S-2	7.3	2620	*	*	*	*	*	8.7	1180	*	*	*	*	*
S-3	7.6	1150	*	*	*	*	*	8.0	1560	*	*	*	*	*
S-4	7.3	370	0.5	0.6	0.2	tr	tr	7.7	196	1.7	1.8	tr	0.3	0.3
S-5	7.3	50	0.5	0.4	0.3	tr	0.5	7.7	0.6	0.2	tr	tr	tr	0.9
S-6	6.5	940	1.2	1.7	0.4	tr	tr	6.8	880	0.8	0.9	tr	0.2	tr
S-7	7.5	0.9	tr	0.7	tr	0.5	0.5	7.5	0.5	tr	0.4	tr	0.3	0.6
S-8	— ^{d)}	—	—	—	—	—	—	6.9	56	*	*	*	*	*
S-9	—	—	—	—	—	—	—	6.9	60	0.9	1.0	tr	tr	tr
S-10	6.8	63	0.5	0.4	0.5	0.9	1.3	7.7	77	1.0	1.0	0.2	0.4	1.0

a) tr: < 0.2 $\mu\text{g/l}$. b) Sampling sites are shown in Fig. 2. c) *: impossible to detect because of contamination. d) —: not measured.

and S-7), where highly polluted effluents from the pulper, digester and their washing processes were treated, the concentration of bisphenol A decreased more than 99%. However, the chlorinated derivatives showed the different patterns of removal; the concentration of 3-CIBPA decreased considerably,

while those of 3,3',5-triCIBPA and 3,3',5,5'-tetraCIBPA did not change. These results are consistent with the results of our biodegradation test⁵⁾ using the supernatant of activated sludge; bisphenol A and 3-CIBPA underwent rapid biodegradation, while 3,3',5-triCIBPA and 3,3',5,5'-tetraCIBPA were

scarcely affected.

In the coagulating sedimentation process (sampling sites S-8 and S-9), the concentration of bisphenol A did not change, presumably due to fluctuation in this process. On the other hand, we observed that 21–36% of bisphenol A in the effluents was removed during the coagulating sedimentation process with water sampled from flocculation basins (data not shown).

In the final effluent (sampling site S-10), bisphenol A was found at a high concentration and all of the chlorinated derivatives were found at a similar level.

Thus, bisphenol A was released at a higher concentration from the pulping process and reacted with a low concentration of residual chlorine to give chlorinated derivatives. Although bisphenol A and 3-CIBPA underwent rapid biodegradation, 3,3',5-triCIBPA and 3,3',5,5'-tetraCIBPA were scarcely biodegraded by treatment with activated sludge. As a result of this different rate of biodegradation, the concentrations of 3,3',5-triCIBPA and 3,3',5,5'-tetraCIBPA increased relative to those of 3-CIBPA and diCIBPA during wastewater recycling.

Isomers of Dichlorinated Bisphenol A

Two isomers (3,3'-diCIBPA and 3,5-diCIBPA) of dichlorinated bisphenol A were found in the final effluents of 4 plants (Table 1), although only 3,3'-diCIBPA was produced by the reaction of bisphenol A with sodium hypochlorite under alkaline conditions.⁵⁾ To clarify the reason for this finding, we investigated the optimal conditions for the formation of 3,5-diCIBPA.

When bisphenol A is dissolved in water, three aqueous forms, undissociated BPA, monoanion and dianion, can be considered and the amount of each is dependent on the pH of the solution. At low pH, only undissociated BPA exists, and the amount of the monoanion increases with increasing pH. With a further increasing in pH, the levels of undissociated BPA and the monoanion decrease, while that of the dianion increases.⁸⁾ The formation of 3,5-diCIBPA may result from electrophilic attack on a phenolate moiety of the monoanion by two chlorines.

To confirm the sensitivity for the formation of these two isomers of diCIBPA, the reaction of bisphenol A with sodium hypochlorite was reacted in aqueous solutions adjusted to pH 3.7, 6.8 and 8.0 with phosphate buffer solution. The results of GC/MS analysis of each reaction mixture are shown in Fig. 3. 3,3'-DiCIBPA was formed preferentially at

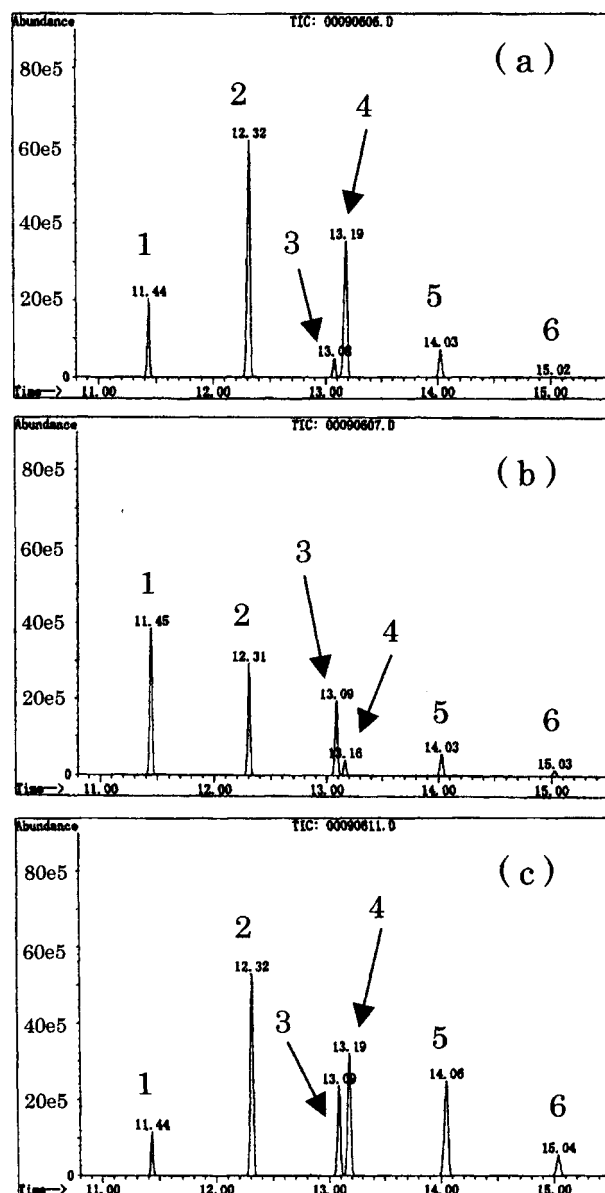

Fig. 3. Total Ion Chromatogram (TIC) of Solutions of Bis(trimethylsilyl) Ethers of Bisphenol A and Its Chlorinated Derivatives

(a) sample taken after the reaction of bisphenol A with NaOCl (10 mg/l) at pH 3.7 for 60 min, (b) at pH 6.8 for 5 min and (c) at pH 8.0 for 5 min. Peaks: (1) BPA, (2) 3-CIBPA, (3) 3,5-diCIBPA, (4) 3,3'-diCIBPA, (5) 3,3',5-triCIBPA, (6) 3,3',5,5'-tetraCIBPA.

pH 3.7 (Fig. 3 (a)), as well as in alkaline solution, as described previously.⁵⁾ 3,5-DiCIBPA was formed preferentially at pH 6.8 (Fig. 3 (b)). At pH 8.0, the intensity of the peak due to 3,3'-diCIBPA is similar to that of 3,5-diCIBPA.

These results revealed that 3,5-diCIBPA was formed in preference to 3,3'-diCIBPA under neutral conditions. In fact, the pH of the process effluent at plant 15 was neutral (pH 6.5–8.0) except for that from the pulping process.

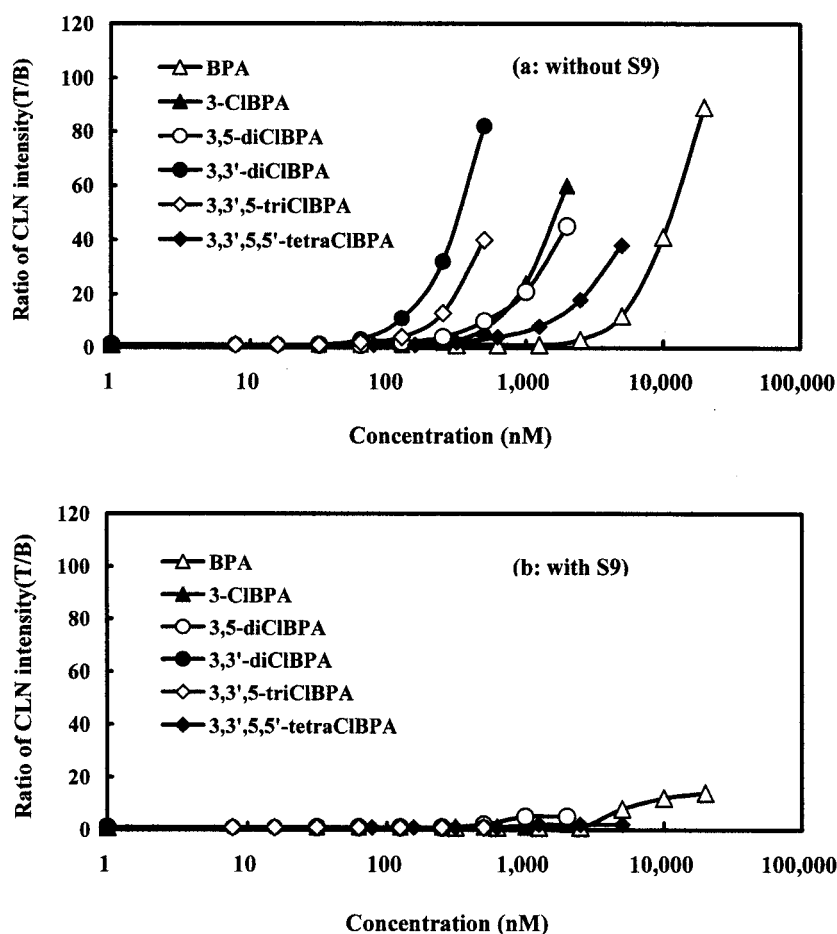

Fig. 4. Comparison of Agonist Activity of Bisphenol A and Its Chlorinated Derivatives Using the Agonist Assay (a) without and (b) with S9

The values represent the ratio (T/B) of the chemiluminescent (CLN) intensity of the treated sample (T) to that of a blank control (B).

Estrogenic Activity of Bisphenol A and its Chlorinated Derivatives

Although bisphenol A has been reported to interact with an estrogen receptor and show weak estrogenic activity,²⁻⁴⁾ the activities of the chlorinated derivatives described above have never been investigated. We attempted to evaluate the estrogenic activity of the chlorinated derivatives by the yeast two-hybrid system.

Nishikawa *et al.* developed a method for the screening for chemicals with hormonal activities using the yeast Y190 in which two expression plasmids, the pGBT9-estrogen receptor ligand-binding domain (pGBT9-ER LBD) and pGAAD424-TIF2, have been introduced.⁶⁾ Shiraishi *et al.* modified this procedure to simplify and improve the sensitivity by adapting the 96-well plate culture method and the chemiluminescent reporter gene assay method.⁷⁾

In the agonist assay without S9, the positive control compound, 17 β -estradiol, exhibited a dose-re-

sponse relationship at concentration ranging from 0 to 2000 pM, and EC_{X10} was 120 pM. In a preliminary test, all of the chlorinated derivatives had different levels of agonist activity. To evaluate of EC_{X10}, the test compounds were prepared in the following concentrations: bisphenol A ranged from 0 to 20000 nM, 3,3',5,5'-tetraCIBPA from 0 to 5000 nM, 3-CIBPA and 3,5-diCIBPA from 0 to 2,000 nM, 3,3'-diCIBPA and 3,3',5-triCIBPA from 0 to 500 nM. The assay with S9 was also carried out under the same conditions.

Figure 4 shows the results of the agonist assay test with and without S9. All of the compounds tested without S9 exhibited a dose-response relationship and all of the chlorinated derivatives were more potent than bisphenol A itself (Fig. 4 (a)). The EC_{X10} values were calculated and the results are shown in Table 3. 3,3'-DiCIBPA shows the most potent activity among these chlorinated derivatives, and its activity was 38-fold greater than that of bisphenol A.

Table 3. Estrogen-agonist Activities of Bisphenol A and Its Chlorinated Derivatives Using the Agonist Assay without S9 in the Yeast Two-hybrid System

Compound	EC _{X10} ^{a)} (nM)	Relative activity
Bisphenol A	4200	1
3-CIBPA	550	8
3,5-diCIBPA	520	8
3,3'-diCIBPA	110	38
3,3',5-triCIBPA	210	20
3,3',5,5'-tetraCIBPA	1500	3

a) EC_{X10} was defined as the concentration at which the ratio of the chemiluminescent signal of the sample to that of a blank control was 10.

3,3',5-TriCIBPA had 20-fold greater activity than bisphenol A. 3-CIBPA and 3,5-diCIBPA were nearly equipotent and 8-fold stronger than bisphenol A.

On the other hand, Fig. 4 (b) shows that the activities of all of the chlorinated derivatives were almost entirely eliminated upon treatment with S9. The activity of bisphenol A (EC_{X10} = 7600 nM) also became very weak when tested with S9 mix. In this case, it is likely that bisphenol A was not fully metabolized due to its high concentration.

Nishihara *et al.* tested the agonist activities of more than 500 chemicals by the two-hybrid assay without S9, and concluded that 64 compounds had such activity. They found that most of the positive compounds have a phenol ring with a moiety with appropriate hydrophobicity at the *para*-position, and that substitution with a bulky moiety at the *ortho*-position reduces this activity.¹⁰⁾ The chlorinated derivatives tested in this study possess chlorine(s) at the *ortho*-position and exhibited 8- to 38-fold stronger activity than bisphenol A. These results do not agree with those obtained by Nishihara *et al.*, but are very interesting. Unexpectedly, 3,3'-diCIBPA had the most potent agonist activity, and was five times more potent than 3,5-diCIBPA. The structure-activity relationship of these compounds is now under investigation.

Chlorinated derivatives of bisphenol A were produced by the reaction of bisphenol A with sodium hypochlorite used as a bleaching agent and were released in the effluent from waste paper recycling plants. From an environmental point of view, more attention should be paid to the use of papers containing bisphenol A as raw materials and to the use of sodium hypochlorite as a bleaching agent in waste paper recycling. The toxicities of other chlorinated derivatives that are likely to be formed by reacting

with sodium hypochlorite should be checked before they are released into the environment.

REFERENCES

- Alexander, H. C., Dill, D. C., Smith, L. W., Guiney, P. D. and Dorn, P. B. (1988) Bisphenol A: Acute aquatic toxicity. *Environ. Toxicol. Chem.*, **7**, 19–26.
- Routledge, E. J. and Sumpter, J. P. (1996) Estrogenic activity of surfactants and some of their degradation products assessed using a recombinant yeast screen. *Environ. Toxicol. Chem.*, **15**, 241–248.
- Coldham, N. G., Dave, M., Sivapathasundaram, S., McDonnell, D. P., Connor, C. and Sauer, M. J. (1997) Evaluation of a recombinant yeast cell estrogen screening assay. *Environ. Health Perspect.*, **105**, 734–741.
- Steinmetz, R., Brown, N. G., Allen, D. L., Bigsby, R. M. and Ben-Jonathan, N. (1997) The environmental estrogen bisphenol A stimulates prolactin release in vitro and in vivo. *Endocrinology*, **138**, 1780–1786.
- Fukazawa, H., Hoshino, K., Shiozawa, T., Matsushita, H. and Terao, Y. (2001) Identification and quantification of chlorinated bisphenol A in wastewater from wastepaper recycling plants. *Chemosphere*, **44**, 973–979.
- Nishikawa, J., Saito, K., Goto, J., Dakeyama, F., Matsuo, M. and Nishihara, T. (1999) New screening methods for chemicals with hormonal activities using interaction of nuclear hormone receptor with coactivator. *Toxicol. Appl. Pharmacol.*, **154**, 76–83.
- Shiraishi, F., Shiraishi, H., Nishikawa, J., Nishihara, T. and Morita, M. (2000) Development of simple operational estrogenicity assay system using the yeast two-hybrid system. *J. Environ. Chem.*, **10**, 57–64.
- Kosky, P. G., Silva, J. M. and Guggenheim, E. A. (1991) The aqueous phase in the interfacial synthesis of polycarbonates. 1. Ionic equilibria and experimental solubilities in the BPA-NaOH-H₂O system. *Ind. Eng. Chem. Res.*, **30**, 462–467.
- Yasuhara, A. and Yamamoto, T. (1999) Formation of bisphenol A from polycarbonate by chemical reaction or structure destruction, 8th Symposium on Environmental Chemistry Program and Abstracts, 324–325.
- Nishihara, T., Nishikawa, J., Kanayama, T., Dakeyama, F., Saito, K., Imagawa, M., Takatori, S., Kitagawa, Y., Hori, S. and Utsumi, H. (2000) Estrogenic activities of 517 chemicals by Yeast Two-Hybrid assay. *J. Health Sci.*, **46**, 282–298.