

from bromine there. no blank value to bother about.

The ashing procedure as described here would obviously not be satisfactory for volatile bromine compounds; nor has it been adequately tested for non-volatile organically bound bromine. In such circumstances it would seem that the bromine might be fixed by heating in sealed tubes with alkali as used by Hardwick (1942).

The method has been found to be useful where the amount of material available for analysis is very limited. It may be regarded as 100 times more sensitive than the titration method described earlier (Hunter, 1953), and it would appear from preliminary observations that it is unnecessary to administer bromide to patients to test the permeability of the barrier between blood and cerebrospinal fluid (see Taylor, Smith & Hunter, 1954), as the method can determine satisfactorily the bromide normally circulating in these fluids. It may further be allowed that the distribution of bromide in plant and animal tissues has not been adequately studied for lack of a precise micro method, and it would appear that the method described here might be adapted to such purposes.

The method has been used to determine bromide in many hundreds of samples of serum and cere-

brospinal fluid and has given rise to no difficulties. We commonly carry out twelve to eighteen determinations in a batch in a few hours.

#### SUMMARY

1. Details are given for the application of the method of Hunter & Goldspink (1954) to the determination of bromide in body fluids.
2. As little as 1  $\mu$ g. Br is enough for analysis, so that less than 1 ml. of serum from people who have received no medicinal bromide, is adequate.
3. The standard deviation of the method is less than 5%, and the extreme range of variation less than 10% of mean values.
4. It is suggested that the method might be useful in the determination of bromine in plant and animal tissues.

I am indebted to Mr J. G. Bowser for technical assistance.

#### REFERENCES

- Francis, A. & Harvey, C. O. (1933). *Biochem. J.* **27**, 1545.  
 Hardwick, P. J. (1942). *Analyst*, **67**, 223.  
 Hunter, G. (1953). *Biochem. J.* **54**, 42.  
 Hunter, G. & Goldspink, A. A. (1954). *Analyst*, **79**, 467.  
 Taylor, L. M., Smith, H. V. & Hunter, G. (1954). *Lancet*, p. 700.

## Fractionation of Phosphates by Paper Ionophoresis and Chromatography

BY H. E. WADE AND D. M. MORGAN

*Microbiological Research Department (Ministry of Supply) Porton, Wiltshire*

(Received 20 December 1954)

Since the importance of phosphorus to cell metabolism was established, several schemes have been described for the fractionation of acid-soluble phosphates. Those most widely used depend upon the different solubilities of the alkaline earth and heavy metal salts in water and ethanol (LePage & Umbreit, 1945; Kaplan & Greenberg, 1944; Sacks, 1949). Even in mixtures of known composition, however, such schemes are liable to give imperfect separations owing to the solubility of some salts being influenced by the presence of others. Another disadvantage of such methods is the relatively large quantity of material required, a disadvantage they share with methods based upon ion exchange (Cohn, 1950; Cohn & Carter, 1950; Volkin, Khym & Cohn, 1951), solvent distribution (Plaut, Kuby & Lardy, 1950) and conventional ionophoresis (Bock & Alberty, 1951).

To overcome these disadvantages the fractionation of phosphates on filter paper is used, but most of the schemes reported are designed for the fractionation and analysis of phosphates of similar constitution, e.g. nucleotides (Magasanik, Vischer, Doniger, Elson & Chargaff, 1950; Davidson & Smellie, 1952; Deutsch & Nilsson, 1953) sugar phosphates (Cohen & McNair Scott, 1950), polyphosphates (Ebel & Volmar, 1951) or for the analysis of adenosine phosphates and phosphates concerned in glycolysis (Hanes & Isherwood, 1949; Bandurski & Axelrod, 1951; Mortimer, 1952). The increasing number of reports of newly discovered phosphates occurring in living material, emphasizes the need for a scheme of analysis which, in addition to giving a good general separation of known phosphates, would facilitate the location, recovery and identification of unknown ones. The following fractiona-

tion of acid-soluble phosphates based upon a combination of paper ionophoresis and chromatography has been designed to accommodate these requirements.

### MATERIALS AND METHODS

Fractionations of phosphate mixtures were carried out on Whatman no. 3 paper purified by washing with *n* formic acid as previously described (Wade & Morgan, 1954). The removal of interfering substances was particularly important in paper ionophoresis where the movement of polyphosphates was otherwise severely retarded. Its importance was demonstrated by comparing the ionophoreses of a mixture of adenosine 5-phosphate, inosine 5-phosphate, adenosine diphosphate (ADP), adenosine triphosphate (ATP), orthophosphate and pyrophosphate on washed (Fig. 1*A*) and unwashed (Fig. 1*B*) paper.

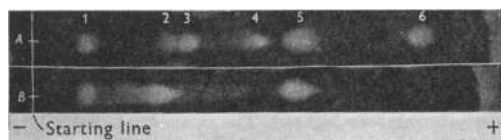

Fig. 1. Ionophoresis of six phosphates on *A*, washed and *B*, unwashed paper. Each spot contained the equivalent of 2–5  $\mu\text{g}$ . P. Phosphates were detected by  $\text{FeCl}_3$ -sulphosalicylic acid spraying. 1, Adenosine 5'-phosphate; 2, inosine 5'-phosphate; 3, ADP; 4, ATP; 5, orthophosphate; 6, pyrophosphate.

The method of paper ionophoresis used was described previously for the analysis of ATP preparations (Wade & Morgan, 1954), but the following modifications were made for the fractionation of more complex mixtures. The ionophoreses were carried out on sheets of paper ( $38 \times 15.5$  cm.) impregnated with an aqueous solution of 9.2% (v/v) *n*-butyric acid and 0.1% (w/v) NaOH exposed to a potential of 400 v (applied across their lengths) for 4.5 hr. at an ambient temp. of 20°. Care was taken to ensure that excess solution was not applied to the anode since, in this event, the superficial solution takes up NaCl from the agar and carries it unevenly down the sheet prejudicing the uniform flow of current over the width of the paper. The impurities present in the agar used made the following purification necessary. Oxoid agar (Oxo Ltd.) was soaked in 0.1 N-HCl for 1 hr. and washed with resin-purified water until no further acid leaked out. It was then suspended in water and treated with NaOH until a drop of the water just turned phenolphthalein indicator pink. It was finally washed thoroughly with water and dried. The machine direction of the paper did not influence ionophoresis.

Ascending chromatography was carried out on sheets of paper  $38 \times 55$  cm. Mixtures of phosphates were applied to points across the width of each sheet 2.5 cm. from one edge. The sheet was then formed into a cylinder by bringing together the longer edges and securing them in the middle and at the top with 'Sellotape' (Adhesive Tapes Ltd., Herts). The form of cylinder was maintained at the base by a large Petri-dish cover into which the solvent, an aqueous solution of 69% (v/v) *n*-butyric acid and 0.85% (w/v)

NaOH, was delivered. The chromatogram was run in a water saturated atmosphere at 20° for 3 days; it was then removed and dried in a current of warm air.

A two-dimensional fractionation of phosphates was carried out by a combination of paper ionophoresis and chromatography. A sheet of paper ( $58 \times 46$  cm.) was wired for a distance of 7.7 cm. along its length (Fig. 2) and supported in a 5.1 cm. deep Perspex frame at one end by the electrode wires (which passed through holes drilled through the Perspex) and at the other by four Perspex hooks which engaged holes pierced across the width of the paper. Mixtures of phosphates were applied to a pencil line (Fig. 2*A*) drawn

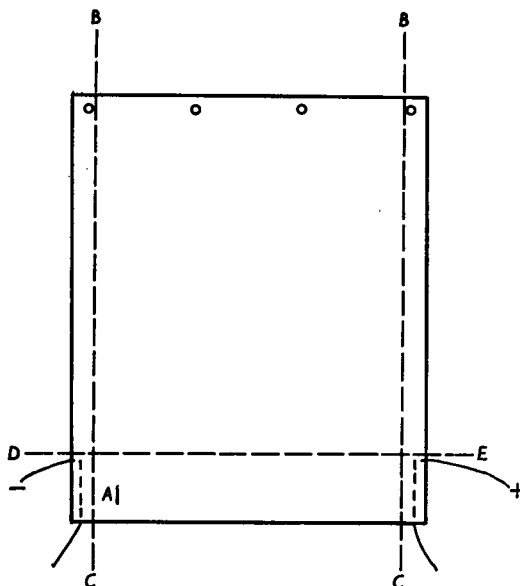

Fig. 2. Construction of a sheet, wired for ionophoresis. *A*, line to which phosphates are applied; *BC*, cutting line for removal of the sheet from the frame; *DE*, folding line for the condensation of phosphate bands that have separated during ionophoresis.

between two points situated 2.5 and 5 cm. from the edge of the paper at a distance of 5 cm. from the cathode electrode and parallel to it. The wires were then treated with agar as previously described (Wade & Morgan, 1954) but particular care was taken to ensure that the inward borders of the agar were parallel to the electrode wires. The paper was sprayed with the ionophoresis solution for a distance of approx. 20 cm. from this edge of the paper. The frame was fixed over a Perspex trough containing sufficient water to maintain a saturated atmosphere and covered with a sheet of plate glass. Several frames were so constructed that they fitted into one another and over a common trough permitting several two-dimensional fractionations to be carried out at one time (Fig. 3).

Ionophoresis was carried out at 400 v for 6 hr. The paper was dried in its frame in a current of warm air and removed from it by cutting along the lines *BC* (Fig. 2). It was then folded along the line *DE* about 3 cm. from the end of the starting line *A* and the fold brought into contact with the

surface of water in a dish in order to condense the bands of phosphates which had separated during ionophoresis and were now distributed between the two electrodes. When the position of the water front indicated that this was almost complete further movement of the phosphates was arrested by bringing the edge of the paper into contact with water and allowing this second water front to meet the first. The phosphates were now situated along a line approximately 2.5 cm. from the edge of the sheet. The sheet was dried, formed into a cylinder and a chromatographic separation carried out as described above. The phosphate spots which result from a two-dimensional separation are almost as compact as those which result from ionophoresis or chromatography alone.

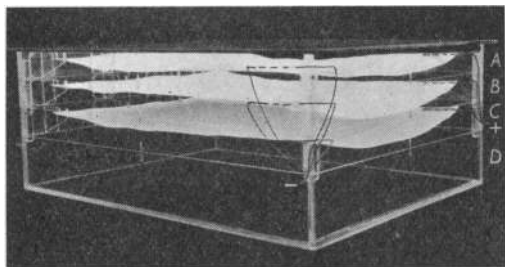

Fig. 3. Construction of the ionophoresis cabinet. Three frames (A-C), constructed as shown in Fig. 2, are supported over a common chamber D. The electrode wires of each pole are joined together at points + and -.

A simple mixture comprised of only a few phosphates can be applied as a spot for two-dimensional fractionation and the condensation process thus avoided, but for the fractionation of complex mixtures the application of the mixture to a line was found more satisfactory (see below).

Most of the phosphate preparations available were in the form of their barium salts. It was found that although the presence of a small concentration of this metal did not interfere with ionophoresis (thus permitting the direct analysis of barium-salt preparations of ATP), serious interference was caused by the high concentration existing in mixtures comprised of several barium-salt preparations. It was necessary in such instances to remove the barium by the gradual addition of cation-exchange resin IR 120 (British Drug Houses Ltd.) to a thick suspension of the salts until dissolution (see below) was obtained. The solution was finally adjusted to approx. pH 4.5 with 5*N*-NaOH. It was necessary to allow at least 3 min. after each addition of NaOH for equilibration to take place. Other metal salt preparations can be conveniently converted into their sodium salts by this method for the purpose of filter-paper analysis.

The following procedure was satisfactory for the preparation of phosphates from 5% trichloroacetic acid extracts. Ethanol (4-6 vol.) was added to the extract to precipitate polysaccharide and similar acid-soluble compounds of high molecular weight. The precipitate was removed and for every mg. phosphorus present in the solution 0.05 ml. 25% (w/v) barium acetate was added (LePage & Umbreit, 1945) together with sufficient NaOH to bring the pH above 8.3. An internal indicator can be used for this purpose. The solution was chilled and the precipitated phosphates were

centrifuged down, washed once in ethanol, dried and made into a thick paste with water. Cation-exchange resin was gradually added until dissolution was complete (or almost complete since some free phosphates are themselves not very soluble in water). The pH was adjusted to approx. pH 4.5 with 5*N*-NaOH and the solution applied to the filter paper for analysis. The use of cation-exchange resin for this conversion is satisfactory for all the phosphates listed in Table 1 but it should be appreciated that a phosphate having more than one strong basic group per molecule may be absorbed on to the resin under the conditions described. It is advisable therefore to test the resin for phosphorus after its use to determine whether or not this has occurred.

The barium salts of most acid-soluble phosphates of biological interest are precipitated by 80% (v/v) ethanol; a very few, e.g. propan-2:3-diol  $\alpha$ -phosphate, are not. In instances where ethanol-soluble barium phosphates are present it is necessary to precipitate such phosphates as lead salts after the manner of Kaplan & Greenberg (1944).

A method of locating phosphates on paper which has proved convenient has been described by Wade & Morgan (1953). Although less specific than that of Hanes & Isherwood (1949), it has the advantage of permitting the recovery and subsequent identification of the phosphate or phosphate mixture located. The concentration of sulphosalicylic acid was varied to suit the widely different concentrations of *n*-butyric acid employed. The location of phosphates after ionophoresis was carried out by spraying first with 0.1% (w/v)  $\text{FeCl}_3 \cdot 6\text{H}_2\text{O}$  in 80% (v/v) ethanol and secondly, after drying, with 1% (w/v) sulphosalicylic acid in 75% (v/v) ethanol. After chromatographic separation the phosphates were detected by spraying with a mixture of 0.1% (w/v)  $\text{FeCl}_3 \cdot 6\text{H}_2\text{O}$  and 7% (w/v) sulphosalicylic acid in 75% (v/v) ethanol.

Reducing substances were conveniently detected by spraying first with 0.5% (w/v) potassium ferricyanide and 10% (v/v) ammonia (sp.gr. 0.88) in 70% (v/v) ethanol and secondly, after drying in a current of warm air, with 1% (w/v)  $\text{FeCl}_3 \cdot 6\text{H}_2\text{O}$  in water.

**Preparation of phosphates.** Sodium triphosphate was prepared by the fusion of 1 mol.  $\text{NaH}_2\text{PO}_4$  with 4 mol.  $\text{Na}_2\text{HPO}_4$  and the purification of the product by ethanol precipitation (Quimby, Mabis & Lampe, 1954).

Glycolaldehyde phosphate was prepared by the reaction of periodic acid upon  $\alpha$ -glycerophosphate (Fleury & Courtois, 1941). Glycollic acid phosphate was prepared by the oxidation of glycolaldehyde phosphate with hypiodite (Fleury & Courtois, 1941). The glycolaldehyde phosphate preparation contained glycollic acid phosphate. The two were easily distinguished, however, by the reducing activity of the former towards ferricyanide.

Glyceraldehyde phosphate and dihydroxyacetone phosphate were prepared by the action of aldolase, prepared by the method of Taylor, Green & Cori (1948), on fructose 1:6-diphosphate in the presence of hydrazine (Meyerhof, 1938). The product was shown by ionophoresis and chromatography to be composed of unchanged fructose 1:6-diphosphate and approximately equal proportions of what were assumed to be the two triose phosphates. The ionophoretic mobilities of all three were sufficiently dissimilar to permit their complete separation by ionophoresis alone, and enable the identities of the trioses to be established from the  $pK_a$  values determined by Kiessling (1934), which show that at pH 3.2 dihydroxyacetone phosphate is the more highly charged of the two.

Propan-2:3-diol  $\alpha$ -phosphate was prepared by the fusion of propylene oxide with  $K_2HPO_4$  (Lampson & Lardy, 1949) and enolpyruvic acid phosphate by the interaction of chlorolactic acid and phosphorus oxychloride (Baer, 1952a). Choline phosphate was prepared by the method of Baer (1952b) and creatine phosphate by the interaction of creatine and phosphorus oxychloride (Lehninger, 1945). Inosine 5'-diphosphate and inosine 5'-triphosphate were prepared by the reduction with nitrous acid of the corresponding adenosine derivatives, purified from commercial samples by ion-exchange (Cohn & Carter, 1950). Pyridoxal phosphate was prepared by the interaction of pyridoxal hydrochloride and phosphorus oxychloride (Heyl, Luz, Harris & Folkers, 1951) and pyridoxamine phosphate by the interaction of pyridoxamine dihydrochloride and  $H_3PO_4$  (Petterson, Sober & Meister, 1952). Flavin-adenine dinucleotide was prepared from baker's yeast by the method of Dimant, Sanadi & Huennekens (1952).

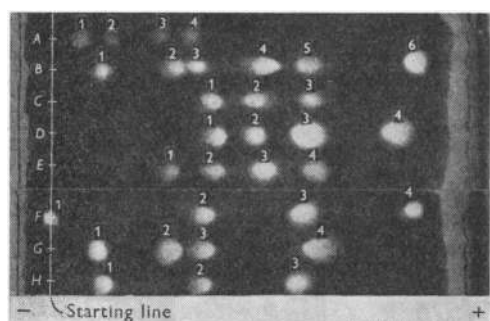

Fig. 4. Ionophoresis of eight mixtures of phosphates. *A*, ribonucleoside 2- and 3-phosphates: 1, cytidylate; 2, adenylate; 3, guanylate; 4, uridylate. *B*, 1, adenosine 5'-phosphate; 2, inosine 5'-phosphate; 3, ADP; 4, ATP; 5, orthophosphate; 6, pyrophosphate. *C*, 1, glucose 6-phosphate; 2, gluconic acid 6-phosphate; 3, orthophosphate. *D*, 1, glucose 1-phosphate; 2,  $\alpha$ -glycerophosphate; 3, fructose 1:6-diphosphate; 4, glyceric acid 2:3-diphosphate. *E*, 1, trehalose phosphate; 2, fructose 6-phosphate; 3,  $\beta$ -glycerophosphate; 4, orthophosphate. *F*, 1, thiamine pyrophosphate; 2, galactose 6-phosphate; 3, orthophosphate; 4, pyrophosphate. *G*, 1, adenosine 5'-phosphate; 2, inosine 5'-phosphate; 3, mannose 6-phosphate; 4, glyceric acid 3-phosphate. *H*, 1, adenosine 3'-phosphate; 2, sedulose 7-phosphate; 3, orthophosphate. Each spot contained the equivalent of 2-5  $\mu$ g. P. Phosphates were detected by  $FeCl_3$ -sulphosalicylic acid spraying.

## RESULTS

The ionophoresis and chromatography techniques described carry out useful separations functioning alone.

Fig. 4 illustrates the paper ionophoresis of eight mixtures of phosphates. The spots produced by paper ionophoresis are quite compact, but where material is scarce the sensitivity and the resolution of the method can be substantially improved by

applying the mixture as a narrow band along the starting line, not as a spot.

Fig. 5 illustrates the chromatography of four mixtures of phosphates. Mixture *D* comprises six ultraviolet-absorbing phosphates, the mono-, di- and tri-phosphates of adenosine and inosine; the position of these phosphates is revealed by taking an ultraviolet contact print of the chromatogram on reflex document paper (Ilford no. 50).

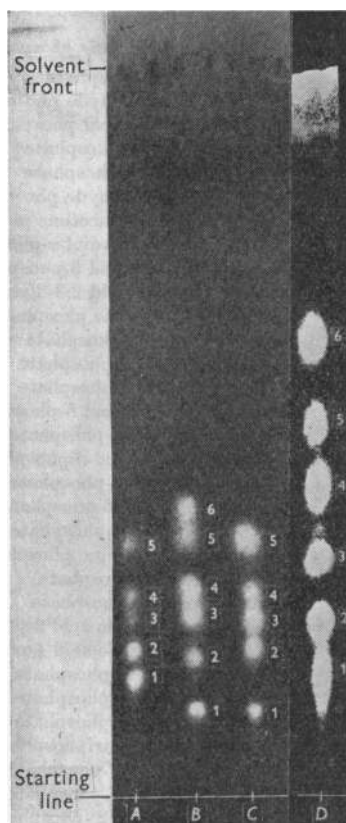

Fig. 5. Chromatography of four mixtures of phosphates. Mixtures *A*, *B* and *C* contained the equivalent of approx. 10  $\mu$ g. P/spot and were detected by  $FeCl_3$ -sulphosalicylic acid. Mixture *D* contained approx. 5  $\mu$ g. P/spot, and its constituents, all of which were ribonucleotides, were detected by making an ultraviolet contact print. *A*, 1, glyceric acid 2:3-diphosphate; 2, glucose 6-phosphate; 3, fructose 6-phosphate; 4, glyceric acid 3-phosphate; 5,  $\alpha$ -glycerophosphate. *B*, 1, fructose 1:6-diphosphate; 2, gluconic acid 6-phosphate; 3, mannose 6-phosphate; 4, ribose 5-phosphate; 5, orthophosphate; 6,  $\beta$ -glycerophosphate. *C*, 1, triose phosphate; 2, sedulose 7-phosphate; 3, glucose 1-phosphate; 4, glyceric acid 3-phosphate; 5, orthophosphate. *D*, 1, inosine 5'-triphosphate; 2, inosine 5'-diphosphate; 3, inosine 5'-phosphate; 4, adenosine 5'-triphosphate; 5, adenosine 5'-diphosphate; 6, adenosine 5'-phosphate.

Table 1. *The movement of phosphates during ionophoresis and chromatography*

$M_o$  indicates the movement of phosphate relative to orthophosphate after ionophoresis. The sources of the phosphates, unless obtained privately, are indicated in the last column: Bd, British Drug Houses Ltd.; Bo, Boehringer & Son Ltd.; Bp, Boots Pure Drug Co.; Lab, prepared in the laboratory; Lg, Light and Co. Ltd.; Pa, Pabst Laboratories; Sw, Schwartz Laboratories Inc.

<i>Inorganic phosphates</i>	$M_o$	$R_F$	Source
1. Orthophosphate	1.00	0.36	Bd
2. Pyrophosphate	1.42	0.25	Bd
3. Triphosphate ( $\text{Na}_5\text{P}_3\text{O}_{10}$ )	1.63	0.16	Lab
4. Trimetaphosphate ( $\text{Na}_4\text{P}_3\text{O}_9$ )	2.05	0.10	—
5. Tetrametaphosphate ( $\text{Na}_4\text{P}_4\text{O}_{12}$ )	1.63	0.10	—
<i>Nitrogen-free organic phosphates</i>			
6. Acetyl phosphate	0.80*	0.52*	Sw
7. Glycolaldehyde phosphate	1.05	0.13	Lab
8. Glycollic acid phosphate	1.23	0.09	Lab
9. $\alpha$ -Glycerophosphate	0.78	0.35	Bp
10. $\beta$ -Glycerophosphate	0.81	0.38	Bp
11. Glyceraldehyde phosphate	0.74	0.36	Lab
12. Dihydroxyacetone phosphate	0.81	0.36	Lab
13. Propan-2:3-diol- $\alpha$ -phosphate	0.83	0.53	Lab
14. Glyceric acid 3-phosphate	1.07	0.26	—
15. Glyceric acid 2:3-diphosphate	1.32	0.15	—
16. Enolpyruvic phosphate	1.20	0.35	Lab
17. Ribose 5-phosphate	0.70	0.27	Sw
18. Glucose 1-phosphate	0.64	0.23	—
19. Glucose 6-phosphate	0.64	0.20	—
20. Gluconic acid 6-phosphate	0.80	0.19	—
21. Fructose 6-phosphate	0.62	0.24	—
22. Fructose 1:6-diphosphate	1.00	0.12	—
23. Mannose 6-phosphate	0.64	0.24	—
24. Galactose 6-phosphate	0.64	0.19	—
25. Sedulose 7-phosphate	0.64	0.20	—
26. Ethanolamine phosphate	0.00	1.58	—
27. Choline phosphate	0.00	0.73	Lab
28. Creatine phosphate	0.61*	0.50*	Lab
29. Pantothenic acid 2-phosphate	0.64	0.62	—
30. Pantothenic acid 4-phosphate	0.64	0.57	—
31. Uridine 2'-phosphate	0.55	0.38	—
32. Uridine 3'-phosphate	0.55	0.39	—
33. Uridine 5'-phosphate	0.55	0.28	—
34. Uridine 5'-triphosphate	1.12	0.16	Pa
35. Cytidine 2'-phosphate	0.13	0.65	—
36. Cytidine 3'-phosphate	0.13	0.59	—
37. Guanosine 2'-phosphate	0.42	0.38	—
38. Guanosine 3'-phosphate	0.42	0.36	—
39. Adenosine 2'-phosphate	0.23	0.72	—
40. Adenosine 3'-phosphate	0.23	0.70	—
41. Adenosine 5'-phosphate	0.21	0.63	—
42. Adenosine 5'-diphosphate	0.58	0.50	Sw
43. Adenosine 5'-triphosphate	0.86	0.41	Sw
44. Inosine 5'-phosphate	0.49	0.33	Sw
45. Inosine 5'-diphosphate	0.82	0.23	Lab
46. Inosine 5'-triphosphate	1.00	0.17	Lab
47. Pyridoxal phosphate	0.32	0.45	Lab
48. Pyridoxamine phosphate	-0.20	0.78	Lab
49. Thiamine pyrophosphate	0.00	0.89	Lg
50. Flavin mononucleotide	0.36	0.43	Lg
51. Flavin-adenine dinucleotide	0.36	0.52	Lab
52. Diphosphopyridine nucleotide	0.13	0.56	Bo
53. Dihydrodiphosphopyridine nucleotide	0.48†	0.40†	Bo

\* Dephosphorylates slowly during separation.

† Oxidizes slowly during separation.

The movement of acid-insoluble phosphates during ionophoresis and chromatography is given in Table 1. The  $M_o$  value (movement of phosphate/movement of orthophosphate) indicates the position of the phosphate relative to orthophosphate after ionophoresis. The  $M_o$  values of triphosphate, tetrametaphosphate, and pyridoxamine phosphate were measured after an ionophoresis of 3 hr. duration. For the measurement of pyridoxamine phosphate the starting line was moved 6 cm. towards the anode. The  $M_o$  value of trimetaphosphate was measured after an ionophoresis of 1.5 hr. duration. A trehalose monophosphate had the characteristics  $M_o=0.47$ ,  $R_f=0.15$ . As the position of the phosphate radical was not known this phosphate has also been omitted from the table.

Three phosphates decompose slowly during their movement on filter paper under the conditions described. Creatine phosphate and acetyl phosphate slowly dephosphorylate resulting in 'streaking' between these esters and orthophosphate; dihydrodiphosphopyridine nucleotide slowly becomes oxidized to diphosphopyridine nucleotide resulting in 'streaking' between these phosphates.

#### DISCUSSION

Two-dimensional filter-paper analyses are carried out by different combinations of chromatography and ionophoresis, of these two-dimensional chromatography is the most extensively used. It has been used for the analysis of acid-soluble phosphates by Bandurski & Axelrod (1951), Mortimer (1952) and Cohen & Oosterbaan (1953). A combination of chromatography and ionophoresis has been used for the fractionation of amino acids by Haugaard & Kroner (1948), and more recently for the fractionation of sugars and protein-polysaccharide hydrolysates by Consden & Stanier (1952). Two-dimensional paper ionophoresis has been used for protein analysis by Kunkel & Tiselius (1951) and by Dicastro (1954). The main deterrents to the wider use of ionophoresis in two-dimensional filter-paper analysis are probably the complicated apparatus required in comparison with chromatography and the existence of variables such as the water loss from the paper and the mass movement of buffer, both of which adversely affect the reproducibility of results; any inconvenience caused by the relief or remedy of these complications is, however, more than compensated by the clean separations usually obtained.

Probably the most convenient method of separating phosphates is by two-dimensional chromatography. Phosphate esters as a group, however, are not very soluble in organic solvents, and the most useful separations are obtained with water-containing solvent systems (Hanes & Isherwood, 1949;

Bandurski & Axelrod, 1951). The water-free system recently used by Mortimer (1952) composed of ethyl acetate, pyridine and formamide, although giving a satisfactory dispersion of phosphates, gave more compact spots when the formamide was replaced by water. For the same reason differences in pH are relied upon to provide the high degree of dissimilarity in behaviour of two solvent systems necessary for a satisfactory resolution by two-dimensional chromatography. The importance of this can be gauged by comparing the two-dimensional fractionation obtained by Bandurski & Axelrod (1951) using a combination of basic and acidic solvent systems with that obtained by Cohen & Oosterbaan (1953) using two acidic solvent systems. The most suitable basic solvent systems contain nitrogenous constituents and their use would hinder subsequent attempts at identification. Ionophoresis at pH 3.2, however, was found to produce a separation sufficiently different from that produced by chromatography with an acid solvent for it to work well in combination with the latter in a two-dimensional fractionation.

An aqueous solution of *n*-butyric acid and sodium butyrate at pH 3.2 provided a satisfactory liquid phase for ionophoresis. At this pH the *n*-butyric acid is only slightly ionized and is below the limits of its most useful buffering range. The strength of acid used, however, has a buffering capacity equivalent to that of a 0.1 N buffering system, which is higher than that normally used for paper ionophoresis. The weakly ionized *n*-butyric acid moves very slowly during ionophoresis and therefore no reservoir of butyrate ions is necessary at the cathode; sodium ions which are lost from the paper are replaced by a reservoir of these ions at the anode in the form of sodium chloride incorporated into the agar. The elimination in this way of reservoirs of buffer lessens the practical difficulties that exist in carrying out ionophoresis on the large sheets of filter paper used in two-dimensional fractionations.

A solvent system comprising an aqueous solution of *n*-butyric acid and sodium butyrate at pH 3.5 was found to give a satisfactory chromatographic separation of phosphates. In deciding the water content of the system it was necessary to compromise the low  $R_f$  values, and compact spots produced by systems with low water contents with the high  $R_f$  values but diffuse spots produced by systems with high water contents. The low water content of the solvent system finally adopted reflects the importance attached to the need for compact spots. It is for the same reason that the initial separation of phosphates as bands and their subsequent condensation with water into spots is recommended in the two-dimensional fractionation instead of the direct separation of the phosphates as spots.

The difficulty of obtaining compact spots by two-dimensional chromatography could probably be relieved by adopting a similar procedure. The nature of the spots, however, is mainly determined by the solvent system, the composition of which must be governed primarily by the usefulness of the separation it produces. Consequently, although a good distribution of phosphates may be obtained by two-dimensional chromatography diffuse spots may be produced. Mortimer (1952) criticized the separations described by Bandurski & Axelrod (1951) on this point and recommends the substitution of the alcohol for organic esters or ketones to improve this, but one of the two schemes he recommends suffers from this fault (Mortimer, 1952).

The method of filter-paper analysis described in this report overcomes some of the disadvantages of previous methods by combining a good general fractionation of acid-soluble phosphates with the production of compact spots and facilitating the recovery and identification of the fractions separated. By providing for the fractionation of the majority of the known phosphates of biological interest it has not, however, been possible to accommodate the extreme lability of creatine phosphate and acetyl phosphate; individual techniques are therefore necessary for the detection and estimation of these esters.

#### SUMMARY

1. Methods are described for the fractionation of mixtures of acid-soluble phosphates by paper ionophoresis and paper chromatography and by a combination of these processes. The techniques used provide for the location and recovery of the fractions separated and facilitate their identification by avoiding the use of nitrogenous reagents.

2. Data are given for the behaviour of fifty-three acid-soluble phosphates of biological interest when subjected to the methods described.

We are indebted to Dr J. Baddiley, Dr C. E. Dent, Dr J. P. Ebel, Dr D. Herbert, Dr S. H. Lipton, Dr Majorie G. Macfarlane, Professor W. T. J. Morgan, Dr A. L. Morrison and Professor A. R. Todd for generous specimens of phosphates, to Mr R. E. Strange for the preparation of phosphate no. 28, and to Mr S. Lovett for the preparation of phosphates nos. 3, 7, 8, 13, 16, 27, 28, 45, 46, 47 and 48. We are also indebted to Dr D. Herbert for his advice during the course of this work. Acknowledgement is made to the Chief Scientist, Ministry of Supply, for permission to publish this paper.

#### REFERENCES

Baer, E. (1952a). *Biochem. Prep.* **2**, 25.  
Baer, E. (1952b). *Biochem. Prep.* **2**, 96.

Bandurski, R. S. & Axelrod, B. (1951). *J. biol. Chem.* **193**, 405.  
Bock, R. M. & Alberty, R. A. (1951). *J. biol. Chem.* **193**, 435.  
Cohen, J. A. & Oosterbaan, R. A. (1953). *Chemisch. Weekblad.* **49**, 308.  
Cohen, S. S. & McNair Scott, D. B. (1950). *Science*, **111**, 543.  
Cohn, W. E. (1950). *J. Amer. chem. Soc.* **72**, 1471.  
Cohn, W. E. & Carter, C. E. (1950). *J. Amer. chem. Soc.* **72**, 4273.  
Conden, R. & Stanier, W. M. (1952). *Nature, Lond.*, **169**, 783.  
Davidson, J. N. & Smellie, R. M. S. (1952). *Biochem. J.* **52**, 594.  
Deutsch, A. & Nilsson, R. (1953). *Acta chem. scand.* **7**, 858.  
Dicastro, G. (1954). *Experientia*, **10**, 27.  
Dimant, E., Sanadi, D. R. & Huenekens, F. M. (1952). *J. Amer. chem. Soc.* **74**, 5440.  
Ebel, J. P. & Volmar, Y. (1951). *C.R. Acad. Sci., Paris*, **233**, 415.  
Fleury, P. & Courtois, J. (1941). *Bull. Soc. chim. Fr.* v, **8**, 69.  
Hanes, C. S. & Isherwood, F. A. (1949). *Nature, Lond.*, **164**, 1107.  
Haugaard, G. & Kroner, T. D. (1948). *J. Amer. chem. Soc.* **70**, 2135.  
Heyl, D., Luz, E., Harris, S. A. & Folkers, K. (1951). *J. Amer. chem. Soc.* **73**, 3430.  
Kaplan, N. O. & Greenberg, D. M. (1944). *J. biol. Chem.* **156**, 511.  
Kiessling, W. (1934). *Biochem. Z.* **273**, 103.  
Kunkel, H. G. & Tiselius, A. (1951). *J. gen. Physiol.* **35**, 89.  
Lampson, G. P. & Lardy, H. A. (1949). *J. biol. Chem.* **181**, 697.  
Lehninger, A. L. (1945). *Manometric Techniques and Related Methods for the Study of Tissue Metabolism*, p. 180. Ed. by Umbreit, W. W., Burris, R. H. & Stauffer, J. F. Minneapolis: Burgess Publishing Co.  
LePage, G. A. & Umbreit, W. W. (1945). *Manometric Techniques and Related Methods for the Study of Tissue Metabolism*, chap. 15. Ed. by Umbreit, W. W., Burris, R. H. & Stauffer, J. F. Minneapolis: Burgess Publishing Co.  
Magasanik, B., Vischer, E., Doniger, R., Elson, D. & Chargaff, E. (1950). *J. biol. Chem.* **186**, 37.  
Meyerohof, O. (1938). *Bull. Soc. Chim. biol., Paris*, **20**, 1033.  
Mortimer, D. C. (1952). *Canad. J. Chem.* **30**, 653.  
Petterson, E. A., Sober, H. A. & Meister, A. (1952). *J. Amer. chem. Soc.* **74**, 570.  
Plaut, G. W. E., Kuby, S. A. & Lardy, H. E. (1950). *J. biol. Chem.* **184**, 243.  
Quimby, O. T., Mabis, A. J. & Lampe, H. W. (1954). *Analyt. Chem.* **26**, 661.  
Sacks, J. (1949). *J. biol. Chem.* **181**, 655.  
Taylor, J. F., Green, A. A. & Cori, G. T. (1948). *J. biol. Chem.* **173**, 591.  
Volkin, E., Khym, J. X. & Cohn, W. E. (1951). *J. Amer. chem. Soc.* **73**, 1533.  
Wade, H. E. & Morgan, D. M. (1953). *Nature, Lond.*, **171**, 529.  
Wade, H. E. & Morgan, D. M. (1954). *Biochem. J.* **56**, 41.