

Research Article

Free Vibration of Layered Circular Cylindrical Shells of Variable Thickness Using Spline Function Approximation

**K. K. Viswanathan, Kyung Su Kim, Kyung Ho Lee,
and Jang Hyun Lee**

Department of Naval Architecture & Ocean Engineering, Inha University, 253 Yonghyun-dong, Nam-gu, Incheon 402-751, Republic of Korea

Correspondence should be addressed to K. K. Viswanathan, visu20@yahoo.com

Received 2 February 2010; Revised 9 July 2010; Accepted 10 August 2010

Academic Editor: Paulo Batista Gonçalves

Copyright © 2010 K. K. Viswanathan et al. This is an open access article distributed under the Creative Commons Attribution License, which permits unrestricted use, distribution, and reproduction in any medium, provided the original work is properly cited.

Free vibration of layered circular cylindrical shells of variable thickness is studied using spline function approximation by applying a point collocation method. The shell is made up of uniform layers of isotropic or specially orthotropic materials. The equations of motions in longitudinal, circumferential and transverse displacement components, are derived using extension of Love's first approximation theory. The coupled differential equations are solved using Bickley-type splines of suitable order, which are cubic and quintic, by applying the point collocation method. This results in the generalized eigenvalue problem by combining the suitable boundary conditions. The effect of frequency parameters and the corresponding mode shapes of vibration are studied with different thickness variation coefficients, and other parameters. The thickness variations are assumed to be linear, exponential, and sinusoidal along the axial direction. The results are given graphically and comparisons are made with those results obtained using finite element method.

1. Introduction

Circular cylindrical shells are used in various fields like aviation, missiles, ship buildings, and chemical industries. Shells made of composite materials with variable thickness are used increasingly, since composite structures are having high specific stiffness, better damping, and shock absorbing characters over the homogeneous ones. The study of vibrational behavior of such shells is very important. The effect of variation of thickness on frequency parameter of the shell, which is made up of different layered materials, has been studied by very few researchers. Baker and Herrmann [1] analysed three layered (Sandwich) shells, including the effects of shear deformation, rotary inertia, and initial stress. Sivadas and

Ganesan [2] studied the vibration of circular cylindrical shells having the thickness variations of linear and quadratic along the axial direction. A series of studies has been made on vibration of cylindrical shells by Tonin and Bies [3], Takahashi et al. [4], Suzuki et al. [5] and Sivadas and Ganesan [6]. Hinton et al. [7] presented free vibration analysis of variable thickness of plates and curved shells using a finite strip formulation. The fundamental frequencies of laminated anisotropic circular cylindrical shells are presented by Sun et al. [8] using finite element method (FEM). Zhang [9] used a propagation approach to analyse the cross-ply laminated composite cylindrical shells. Hufenbach et al. [10] presented a study on vibration and damping behaviour of multilayered composite cylindrical shells using analytic calculation method. Sakiyama et al. [11] and Tsuiji and Sueoka [12] analysed the vibration of cylindrical panel using the Raleigh-Ritz method. Recently, Tizzi [13] applied the Ritz procedure for optimization of cylindrical shell profile under a frequency constraint, and Toorani and Lakis [14] studied the vibrations of nonuniform composite shells applying the combination of hybrid finite element analysis and shearable shell theory.

Mizusawa and Kito [15] applied the spline strip method to study the vibration of cross-ply laminated cylindrical panels. This method involved expressing displacement functions in a strip element as the product of basic function series in the axial direction and B-spline functions in the circumferential direction. However, there seems to be no work carried out so far on vibration of symmetric angle-ply layered cylindrical shells with variable thickness using Bickley spline function, which is done in the present study.

The present work analyses the flexural free vibration of layered circular cylindrical shells of variable thickness. The equations of motion are derived using Love's first approximation theory for homogeneous shells. The layers are considered to be thin, elastic, specially orthotropic, or isotropic and assumed to be perfectly bonded together and move without interface slip. Three different thickness variations (linear, exponential, and sinusoidal) are considered along the axial direction of the cylinder. The governing coupled differential equations are obtained in terms of the reference surface displacements which are in longitudinal, circumferential, and transverse directions. Assuming the displacement functions in a separable form, they reduce to a system of ordinary differential equations on a set of displacement functions which are functions of meridional coordinate only. Two sets of boundary conditions are imposed and two types of materials are used to analyse the problem. In general, the equations have no closed form solution, so that the numerical solution techniques have to be resorted to.

The spline function technique is adopted to solve the coupled differential equations which are in three displacement functions. Bickley [16] successfully tested the spline collocation method over a two-point boundary value problem with cubic spline. Viswanathan and Navaneethakrishnan [17] and Viswanathan and Kim [18] have also demonstrated this, along with its attractive features of elegance in handling and convergence. Recently, Viswanathan et al. [19] studied the vibration of cross-ply cylindrical shell walls including shear deformation theory using the spline function techniques. The advantage of this method is that a chain of lower-order approximations than the global higher order approximation.

The three displacement functions are approximated using cubic and quintic splines. Collocation with these splines yields a set of field equations which, along with the equations of boundary conditions, reduce to a system of homogeneous simultaneous algebraic equations on assumed spline coefficients which results in a generalized eigenvalue problem. This eigenvalue problem is solved using eigensolution technique to obtain as many frequencies as required, starting from the least. From the eigenvectors, the spline coefficients can be found to construct the mode shapes.

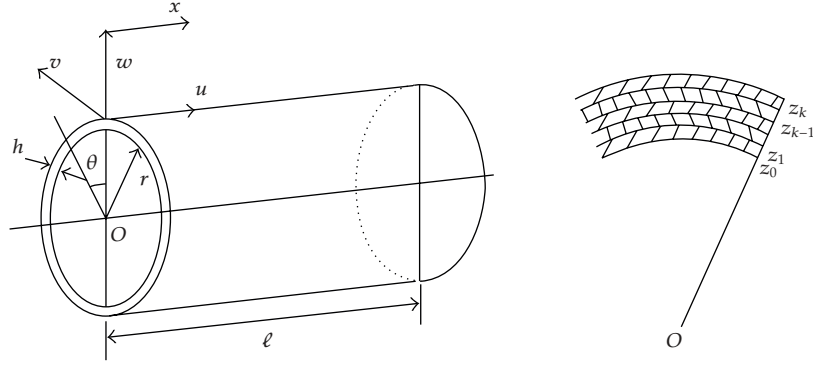

Figure 1: Layered circular cylindrical shell of constant thickness: geometry.

2. Formulation of the Problem

The system of differential equations in terms of longitudinal, circumferential, and transverse displacements components is derived, which characterise the vibration of a thin shell of revolution. The general line of procedure of Ambartsumyan [20] for the classical theory of thin shell is adopted. The development is based on the Love's first approximation theory in which the rotatory inertia and transverse shear deformation are neglected. Such an approach results in an analytically simpler procedure, by way of less number of equations of motion and avoidance of nonlinear terms, thereby conveniencing the application of spline function method. The coordinate system and the geometric parameters of the laminated cylindrical shells of constant thickness are shown in Figure 1.

In general, the thickness of the k th layer of the shell is assumed in the form

$$h_k(x) = h_{0k}g(x), \quad (2.1)$$

where h_{0k} is a constant thickness and

$$g(x) = 1 + C_\ell \frac{x}{\ell} + C_e \exp\left(\frac{x}{\ell}\right) + C_s \sin\left(\frac{\pi x}{\ell}\right). \quad (2.2)$$

Here ℓ is the length of the cylinder, C_ℓ , C_e , and C_s are the coefficients of linear, exponential, and sinusoidal variations, respectively.

The thickness of the layers is not completely independent. Their dependence is given by

$$\sum_k (z_k^2 - z_{k-1}^2) \rho_k = 0, \quad (2.3)$$

where ρ_k is the mass density of the k th layer and z_k is the distance of the outer boundary of the k th layer from the reference surface. This may be interpreted as determining one of the z_k

in terms of the rest of z_k . If the shell wall has only two layers, in particular, one can obtain

$$\begin{aligned} z_0(x) &= z_{00}g(x), \\ z_1(x) &= z_0(x) + h_1(x) = z_{01}g(x), \\ z_2(x) &= z_1(x) + h_2(x) = z_{02}g(x). \end{aligned} \quad (2.4)$$

Here $z_{0k} = z_{0k-1} + h_{0k-1}$. It may be noted that for linear and sinusoidal variation of thickness $z_{0k} = z_k(0)$.

The stress resultants and moment resultants are expressed in terms of the longitudinal, circumferential, and transverse displacements u , v , and w of the reference surface. The displacements are assumed in a separable form given by

$$\begin{aligned} u(x, \theta, t) &= U(x) \cos n\theta e^{i\omega t}, \\ v(r, \theta, t) &= V(r) \sin n\theta e^{i\omega t}, \\ w(r, \theta, t) &= W(r) \cos n\theta e^{i\omega t}, \end{aligned} \quad (2.5)$$

where x and θ are the longitudinal and rotational coordinates, t is the time, ω is the angular frequency of vibration and n is the circumferential node number. Using (2.5) in the constitutive equations and the resulting expressions for the stress resultants and the moment resultants in the equilibrium equations, the governing differential equations of motion are obtained in the form

$$\begin{bmatrix} L_{11} & L_{12} & L_{13} \\ L_{21} & L_{22} & L_{23} \\ L_{31} & L_{32} & L_{33} \end{bmatrix} \begin{bmatrix} U \\ V \\ W \end{bmatrix} = [0]. \quad (2.6)$$

The operators L_{ij} ($i, j = 1, 2, 3$) are defined in Appendix A.

3. Method of Solution

The differential equations on the displacement functions of (2.6) contain derivatives of third order in U , second order in V , and fourth order in W . Therefore, the present form is not suitable to the solution procedure we propose to adopt. Hence, the equations are combined within themselves and a modified set of equations is derived. The modified equations now become as 2nd order in U , 2nd order in V , and 4th order in W , and is given by

$$\begin{bmatrix} L_{11} & L_{12} & L_{13} \\ L_{21} & L_{22} & L_{23} \\ L_{31}^* & L_{32}^* & L_{33}^* \end{bmatrix} \begin{bmatrix} U \\ V \\ W \end{bmatrix} = [0]. \quad (3.1)$$

The new operators L_{31}^* , L_{32}^* , and L_{33}^* are given in Appendix B.

The parameters are nondimensionalised as

$$\begin{aligned}
 \lambda &= \ell\lambda', \quad \text{a frequency parameter,} \\
 \delta_k &= \frac{h_k}{h}, \quad \text{a relative thickness ratio of the } k\text{th layer,} \\
 L &= \frac{\ell}{r}, \quad \text{a length parameter,} \\
 H &= \frac{h}{r}, \quad \text{ratio of total thickness to radius,} \\
 X &= \frac{x}{\ell}, \quad 0 \leq x \leq \ell, \quad \text{a distance coordinate and } X \in [0, 1].
 \end{aligned} \tag{3.2}$$

Here r is the radius of the cylinder and h is the total thickness of the shell. Also we define $\delta = \delta_1$ and $\delta_2 = 1 - \delta_1$, since we consider only two layers.

The displacement functions $U(X)$, $V(X)$, and $W(X)$ are approximated by the cubic and quintic spline functions $U^*(X)$, $V^*(X)$, and $W^*(X)$ as stated below

$$\begin{aligned}
 U^*(X) &= \sum_{i=0}^2 a_i X^i + \sum_{j=0}^{N-1} b_j (X - X_j)^3 H(X - X_j), \\
 V^*(X) &= \sum_{i=0}^2 c_i X^i + \sum_{j=0}^{N-1} d_j (X - X_j)^3 H(X - X_j), \\
 W^*(X) &= \sum_{i=0}^4 e_i X^i + \sum_{j=0}^{N-1} f_j (X - X_j)^5 H(X - X_j).
 \end{aligned} \tag{3.3}$$

The boundary conditions are used as follows: (i) both the edges are clamped (C–C) and (ii) both the edges are hinged (H–H). The resulting field and boundary conditions give rise to the generalized eigenvalue problem of the form

$$[M]\{q\} = \lambda^2[P]\{q\}, \tag{3.4}$$

where $[M]$ and $[P]$ are matrices of order $(3N+7) \times (3N+7)$, $\{q\}$ is a matrix of order $(3N+7) \times 1$, and $N + 1$ is the number of knots of the splines on axial direction. The parameter λ is the eigenparameter and $\{q\}$ the eigenvector whose elements are the spline coefficients. Only two-layer shells are considered with $\delta =$ ratio of thickness of the first mentioned layer to the total thickness, at the one edge of the cylinder.

4. Results and Discussion

Convergence study is made for the frequency parameter value to fix the number of knots N of the spline function. As mentioned earlier, only two-layered shells are considered and it is tested for High strength graphite (HSG) and S-glass epoxy (SGE) material combinations.

Table 1: Material properties of HSG and SGE.

Material	Density $\rho \times 10^3 \text{ N} - \text{s}^2/\text{m}^4$	Young's Modulus $E_x \times 10^{10} \text{ N}/\text{m}^2$	Young's Modulus $E_\theta \times 10^{10} \text{ N}/\text{m}^2$	Shear Modulus $\times 10^{10} \text{ N}/\text{m}^2$	Poisson Ratio $\nu_{x\theta}$
HSG	1.5892	12.40	1.03	0.54933	0.27
SGE	2.0431	5.17	1.17	0.55060	0.25

Table 2: Comparison of natural frequencies for free vibration of cylindrical shell of exponential variation in thickness under C–C boundary condition; $h = h_0 e^{-kx}$ and $n = 2$.

k	Length parameter, L	Takahashi et al. [4]	Sivadas and Ganesan [2]	Present value
0.4	0.6768	1.2	1.2652	1.1522
0.6	0.6608	1.2	1.2606	1.1632
0.8	0.6460	1.2	1.2564	1.1816
1.0	0.6321	1.2	1.2528	1.2037

Table 1 shows the material properties of High strength graphite (HSG) and S-glass epoxy (SGE).

After a number of trials, it is found that the number of knots N could be taken as 14, since for the next value of N the percent change in values of λ are very low, the maximum being 0.35%. The results are not furnished here due to space constraints.

Comparative studies are next made for homogeneous cylindrical shells of exponential variation in thickness. Table 2 presents the natural frequencies obtained for the shell with C–C boundary conditions and compared with the results obtained by Takahashi et al. [4] and Sivadas and Ganesan [2]. The present frequency parameter $\lambda = \omega \ell \sqrt{R_0/A_{11}^c}$ converted into the parameter α that has been given by Sivadas and Ganesan [2], where $\alpha^4 = \rho a^2 (1 - \nu^2) \omega^2 / E$. The percentage changes between the present results and Sivadas and Ganesan [2] for $k = 0.4, 0.6, 0.8,$ and 1.0 are 9.8%, 8.4%, 6.3%, and 4%, respectively. It shows that, when the value of k increases the difference in percentage decreases. This may be due to the method we adopted. In this paper the value of k is taken as 1 in all the cases since the difference in percentage is minimum for $k = 1$ when compared with results obtained by Sivadas and Ganesan [2]. This indicates that the correctness of the analysis and accuracy of the results by using spline function techniques.

In this work, asymmetric free vibration of layered circular cylindrical shells of variable thickness is studied. Only two-layered materials with HSG and SGE combinations are used in this analysis, and the first three meridional modes are considered in all the analyses that follow.

In Figure 2, the variation of frequency parameter $\lambda_m (m = 1, 2, 3)$ with respect to the increase of the relative thickness ratio δ for the layered cylindrical shells under linear variation in thickness ($C_\ell \neq, C_e = C_s = 0$) is displayed. In this case, it can be assumed that $C_\ell = 1/\eta - 1$, where η is the taper ratio $h_k(0)/h_k(1)$. The values of the ratio of the shell's constant thickness to radius (H) and the ratio of the shell length to the radius (L) are fixed as 0.02 and 1.5, respectively. The value of taper ratio is fixed as $\eta = 0.75$. The two layers of the shell are arranged in the order of HSG and SGE materials. Thus, when $\delta = 0$, the inner layer disappears, and the shell is homogeneous, which is made of SGE material. When $\delta = 1$, the outer layer disappears, again the shell is homogeneous, made of HSG material. Figures 2(a) and 2(b) correspond to the node number $n = 4$, with C–C and H–H boundary conditions,

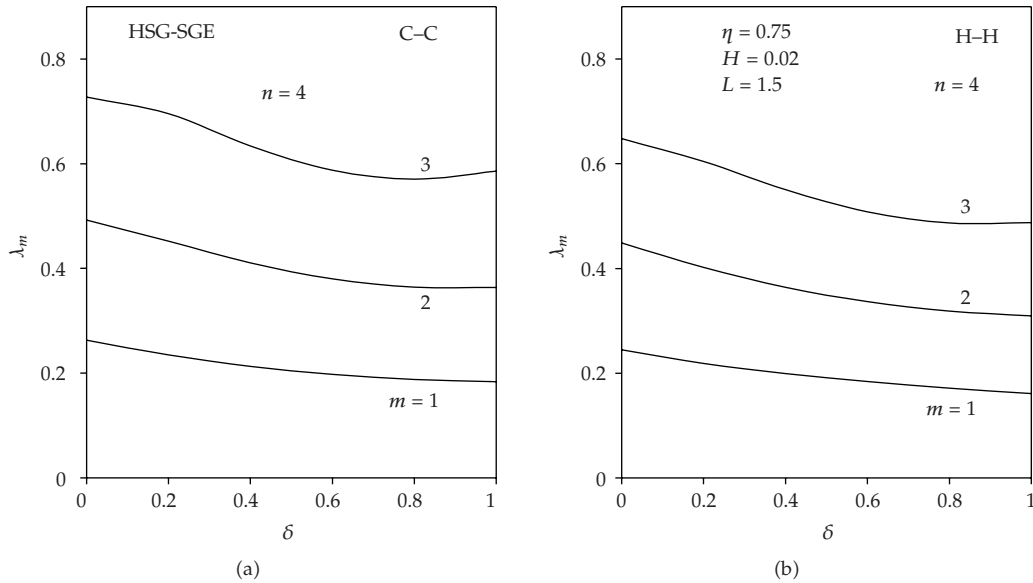

Figure 2: Variation of frequency parameter with relative layer thickness: linear variation in thickness of layers.

respectively. It is clearly seen that as δ increase, λ_m decreases for a $m = 1, 2$ for all values of δ and $\lambda_m (m = 3)$ decrease for $\delta \leq 0.8$ and a small increase for $\delta > 0.8$. If the order of the materials are inverted (SGE-HSG) then the frequency parameter λ_m increases as δ increase for all $m = 1, 2, 3$.

The results are not shown here for want of space. For the extreme values of δ , equal to 0 or 1, the shell becomes homogeneous, with the material of either of the two layers. It is seen that it is possible to attain a desired frequency, between these two extreme values by suitably choosing the value of δ . This is interesting from a design point of view.

Figure 3 presents the variation of frequency parameters with relative thickness of layer δ for HSG-SGE materials by fixing $H = 0.02$ and $L = 1.5$ under C-C and H-H boundary conditions. The thickness varies exponentially ($C_\ell = C_s = 0$; $C_e \neq 0$) and coefficient C_e is fixed as 0.2. Figures 3(a) and 3(b) correspond to the node number $n = 4$, with C-C and H-H boundary conditions, respectively. In Figure 4, the nature of the frequency parameter for sinusoidal variation in thickness ($C_\ell = C_e = 0$; $C_s \neq 0$) is depicted. The other parameters H and L are fixed with $C_s = 0.25$. The effect of frequency parameters presented in Figures 3 and 4 almost has the similar pattern as discussed in Figure 2 (linear variation).

Figures 5(a)–5(f) show the manner of variation of the frequency parameter with reference to the circumferential node number n . The range of n is considered between 0 and 10. A shell of HSG-SGE lamination under C-C and H-H boundary conditions is considered with $H = 0.02$, $L = 1.5$, and $\delta = 0.4$. Figures 5(a)–5(c) show the effect of n on λ_m for C-C conditions and Figures 5(d)–5(f) show the effect of n on λ_m for H-H conditions. All the three types of variation in thickness of layers are considered, as indicated in the diagrams. It is seen that all the frequency parameter values decrease upto $n = 5$ and then increase. The curvature at the turning points seems to be greater for lower modes. The absolute and relative differences between the maximum and minimum values of λ_m , caused in the range of values of n considered, is more in the case of C-C boundary conditions than with that of

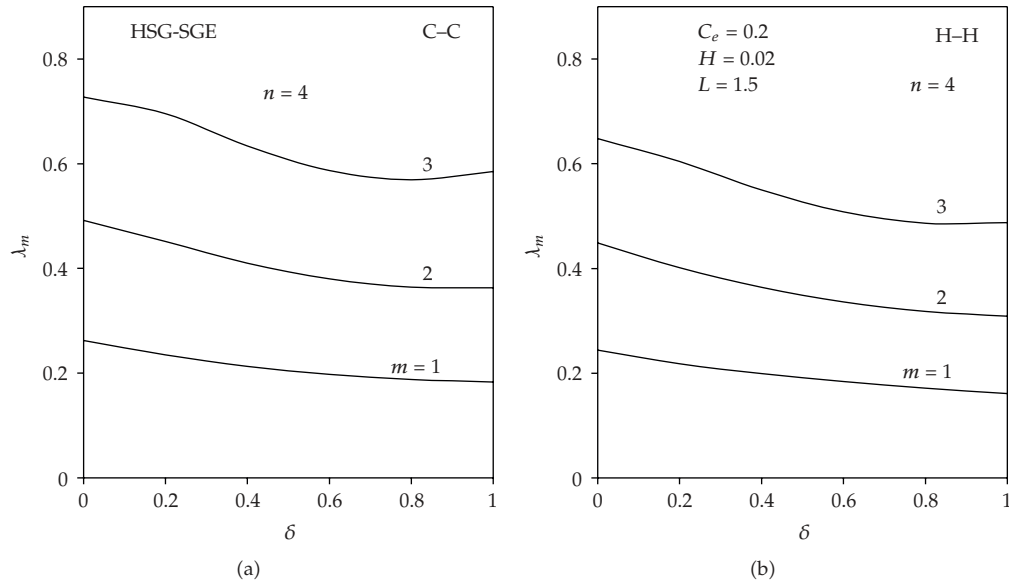

Figure 3: Variation of frequency parameter with relative layer thickness: exponential variation in thickness of layers.

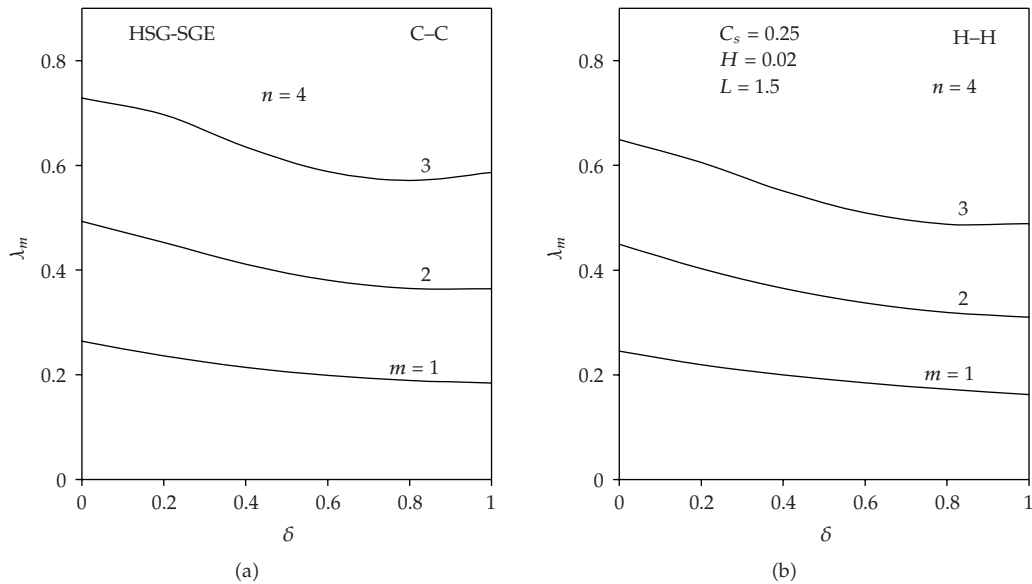

Figure 4: Variation of frequency parameter with relative layer thickness: sinusoidal variation in thickness of layers.

H-H boundary conditions. The kind of thickness variation in layers does not seem to greatly affect the nature of variation of λ_m with n .

The frequency parameter λ_m is explicitly a function of the length ℓ of the cylinder. Hence, when studying the influence of the length of the cylinder on its vibrational behaviour, the actual frequency ω_m ($m = 1, 2, 3$), and not λ_m , is considered. Figures 6(a)–6(c) depict

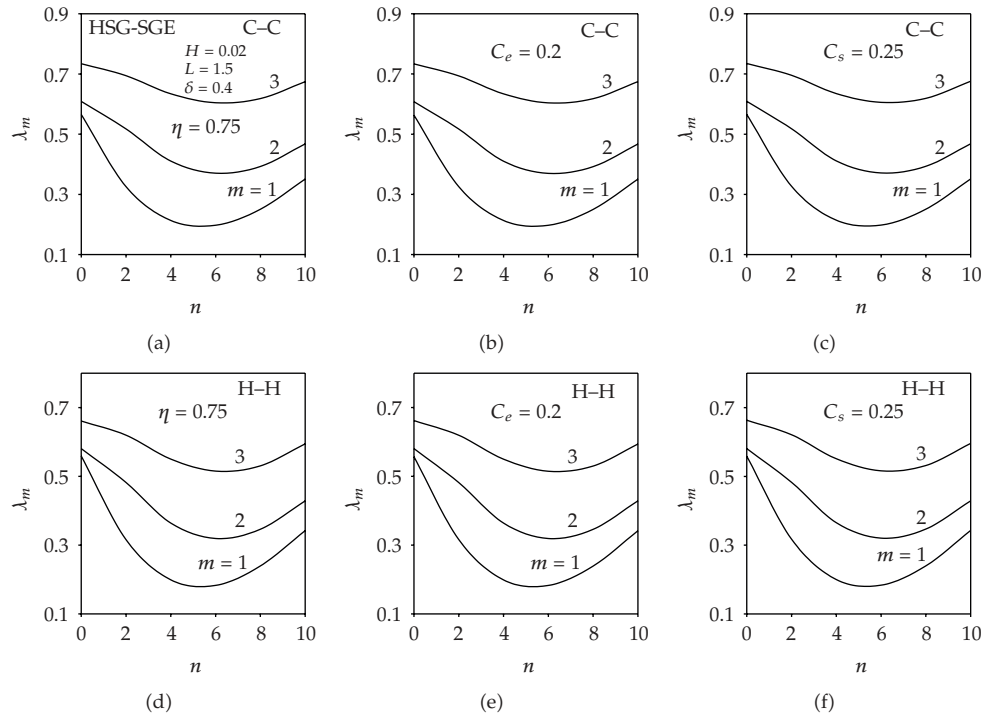

Figure 5: Effect of circumferential node number on frequency parameter for different types of variation in thickness of layers.

the manner of variation of the actual frequency ω_m (in 10^3 Hz) with respect to the length parameter L for HSG-SGE layered cylinders under C–C boundary conditions with $H = 0.02$, $\delta = 0.4$, and $n = 4$. All the three types of variation in thickness of layers are considered. As L increases, ω_m is observed to decrease, in general. The decrease is fast for very short shells (for $0.5 < L < 0.75$ herein), the rate of decrease increasing with higher modes and then the decrease is very low for $L > 0.9$. The percent changes in ω_1 over the range of $0.5 < L < 2.0$ for three cases (linear, exponential and sinusoidal variations) depicted are, respectively: (a) 452.034%, (b) 450.476%, and (c) 453.573% for C–C conditions. Similar phenomenon is observed in the case of layered cylindrical shells of variable thickness under H–H boundary conditions shown in Figure 7. The percent changes in ω_1 over the range of L considered, for three different variations, are (a) 272.268%, (b) 270.533%, and (c) 273.858% for H–H conditions.

In Figure 8, the influence of the nature of variation of thickness of the layers of the shell on its vibrational behaviour is studied. A HSG-SGE shell held under C–C boundary conditions with the three types of variation in thickness of layers is considered, with $H = 0.02$, $L = 1.5$, $\delta = 0.4$, and $n = 4$. Figure 8(a) relates to linear variation in thickness of layers. The thickness is constant when the taper ratio $\eta = 1$. Variation of λ_m ($m = 1, 2, 3$) with respect to η for $0.5 \leq \eta \leq 2.1$ is studied. It is seen that λ_m is almost constant for all the values of η . The effect of exponential variation in thickness of layers is analysed in Figure 8(b). When $C_e = 0$, the thickness is uniform. The thickness at the end $x = \ell$ of the cylinder is higher or lower than the thickness at the other end $x = 0$ according to $C_e \leq 0$. The effect of sinusoidal variation in thickness of layers on frequency parameters is studied in Figure 8(c). These effects are almost

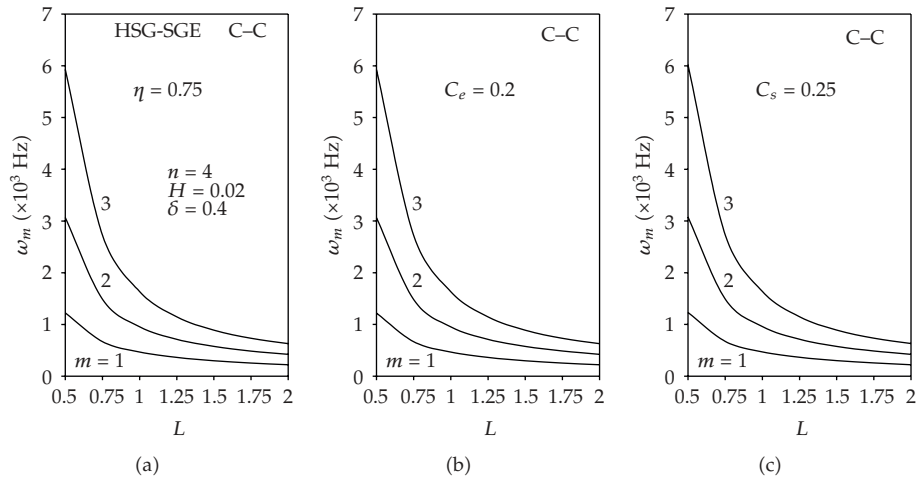

Figure 6: Effect of length of the shell on frequency parameter for different types of variation in thickness of layers under C–C boundary conditions.

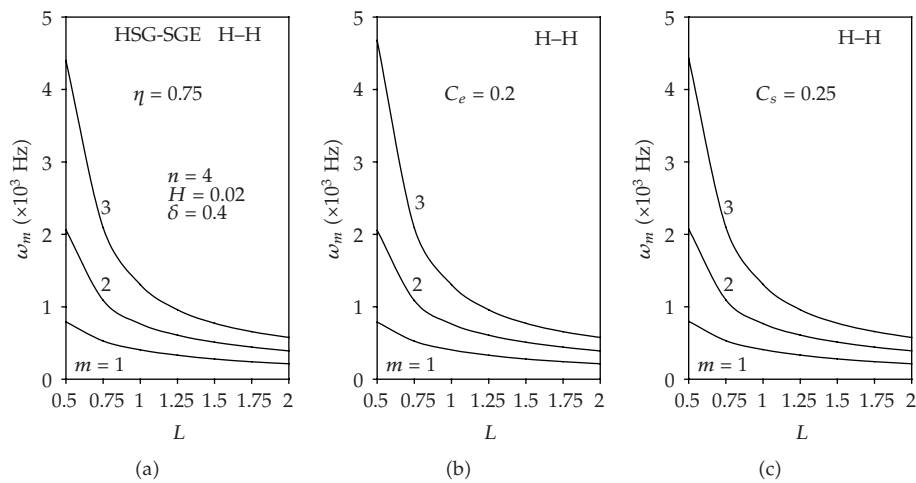

Figure 7: Effect of length of the shell on frequency parameter for different types of variation in thickness of layers under H–H boundary conditions.

similar to those due to the exponential variation discussed above. Here, the coefficient of thickness variation is considered over the range $[-0.5, 0.5]$. The thickness of the shell is the same at $x=0$ and $x=\ell$; the surface of the shell is convex or concave for $0 < x < \ell$.

In Figure 9, the influence of the taper ratio η , the coefficient of exponential variation of thickness C_e and the coefficient of sinusoidal variation C_s on λ_m are depicted, along with the effect of the H–H boundary conditions. The effect of λ_m is almost same for all the cases of linear and exponential variation, as described in Figure 8. In this variation, the C–C boundary conditions contribute slightly higher values to the influence of the coefficients of thickness variation on frequencies than the H–H conditions contributing values to the influence of the coefficients of thickness variation on frequencies.

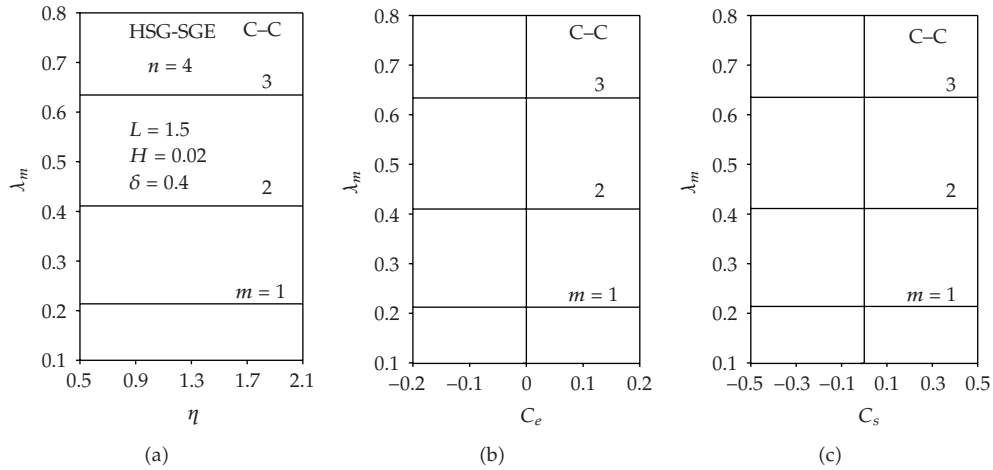

Figure 8: Effect of taper ratio, coefficient of exponential variation, and coefficient of sinusoidal variation on frequency parameter under C–C boundary conditions.

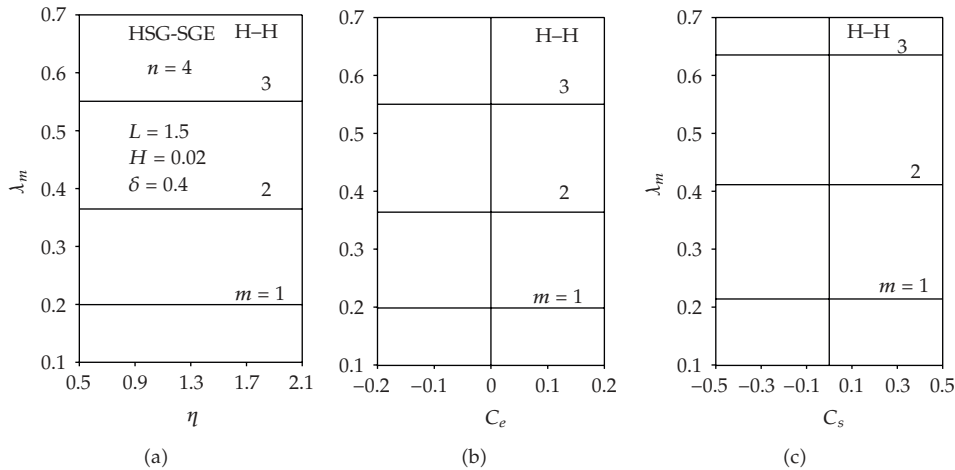

Figure 9: Effect of taper ratio, coefficient of exponential variation and coefficient of sinusoidal variation on frequency parameter under H–H boundary conditions.

5. Conclusion

The influence of the natural frequencies of the vibration of layered cylindrical shells of variable thickness has been analysed. The materials of the layers, length of the shell, and coefficients of variable thickness affect the frequency. A desired frequency of vibration may be obtained by a proper choice of the relative thickness of the layers, length parameter, and the coefficient of thickness variations. The clamped-clamped (C–C) boundary conditions give rise to higher frequencies in comparison with hinged-hinged (H–H) boundary conditions. The nature of variation in thickness of layers considerably affects the natural frequencies. When the circumferential node number is increased, the frequencies initially decrease and then increase. The effect of increasing the length of the cylinder is a decrease in frequencies, for all kinds of variation in thickness of layers. This study also shows the elegance and usefulness of the spline functions with application of the collocation method for boundary value problems.

Appendices

A. The operators $L_{ij}(i, j = 1, 2, 3)$ are:

The differential operators $L_{ij}(i, j = 1, 2, 3)$ appearing in (2.6) are

$$\begin{aligned}
L_{11} &= \frac{d^2}{dx^2} + \frac{g'}{g} \frac{d}{dx} - s_{10} \frac{n^2}{r^2} + \lambda'^2, \\
L_{12} &= \frac{n}{r} \left[s_2 + s_{10} + \frac{1}{r} (s_5 + s_{11}) \right] \frac{d}{dx} + \frac{n}{r} \left[s_2 + s_5 \frac{1}{r} \right] \frac{g'}{g}, \\
L_{13} &= -s_4 \frac{d^3}{dx^3} - s_4 \frac{g'}{g} \frac{d^2}{dx^2} + \left[\frac{n^2}{r^2} (s_5 + 2s_{11}) + s_2 \frac{1}{r} \right] \frac{d}{dx} + \frac{g'}{gr} \left[s_2 + s_5 \frac{1}{r} \right], \\
L_{21} &= -\frac{n}{r} \left[s_2 + s_{10} + \frac{1}{r} (s_5 + s_{11}) \right] \frac{d}{dx} - \frac{n}{r} \left[s_{10} + s_{11} \frac{1}{r} \right] \frac{g'}{g}, \\
L_{22} &= \left[s_{10} + \frac{2s_{11}}{r} + \frac{s_{12}}{r^2} \right] \frac{d^2}{dx^2} + \frac{g'}{g} \left[s_{10} + \frac{2s_{11}}{r} + \frac{s_{12}}{r^2} \right] \frac{d}{dx} - \frac{n^2}{r^2} \left[s_3 + \frac{2s_6}{r} + \frac{s_9}{r^2} \right] + \lambda'^2, \\
L_{23} &= \frac{n}{r} \left[2s_{11} + s_5 + \frac{2s_{12}}{r} + \frac{s_8}{r} \right] \frac{d^2}{dx^2} + \frac{n}{r} \frac{g'}{g} \left[2s_{11} + \frac{2s_{12}}{r} \right] \frac{d}{dx} - \frac{n}{r^3} \left[(1+n^2)s_6 + n^2 \frac{s_9}{r} \right] - \frac{n}{r^2} s_3, \\
L_{31} &= s_4 \frac{d^3}{dx^3} + 2s_2 \frac{g'}{g} \frac{d^2}{dx^2} + \left[s_4 \frac{g''}{g} - \frac{s_2}{r} - \frac{n^2}{r^2} (s_5 + 2s_{11}) \right] \frac{d}{dx} - 2s_{11} \frac{n^2}{r^2} \frac{g'}{g}, \\
L_{32} &= \frac{n}{r} \left[s_5 + 2s_{11} + \frac{1}{r} (s_8 + 2s_{12}) \right] \frac{d^2}{dx^2} + 2 \frac{n}{r} \frac{g'}{g} \left[s_5 + s_{11} + \frac{1}{r} (s_8 + s_{12}) \right] \frac{d}{dx} \\
&\quad - \frac{n^3}{r^3} \left(s_6 + \frac{s_9}{r} \right) - \frac{n}{r} \left(\frac{s_3}{r} + \frac{s_6}{r^2} - s_5 \frac{g''}{g} - \frac{s_8}{r} \frac{g''}{g} \right), \\
L_{33} &= -s_7 \frac{d^4}{dx^4} - 2s_7 \frac{g'}{g} \frac{d^3}{dx^3} + \left[\frac{2s_5}{r} - s_7 \frac{g''}{g} + \frac{2n^2}{r^2} (s_8 + 2s_{12}) \right] \frac{d^2}{dx^2} \\
&\quad + \frac{g'}{g} \left[\frac{2s_5}{r} + \frac{2n^2}{r^2} (s_8 + 2s_{12}) \right] \frac{d}{dx} - \left[\frac{n^4}{r^4} s_9 + \frac{s_3}{r^2} - \frac{s_5}{r} \frac{g''}{g} + \frac{n^2}{r^2} \left(\frac{2s_6}{r} - s_8 \frac{g''}{g} \right) \right] + \lambda'^2,
\end{aligned} \tag{A.1}$$

where

$$\begin{aligned}
s_2 &= \frac{A_{12}^c}{A_{11}^c}, & s_3 &= \frac{A_{22}^c}{A_{11}^c}, & s_4 &= \frac{B_{11}^c}{A_{11}^c}, & s_5 &= \frac{B_{12}^c}{A_{11}^c}, & s_6 &= \frac{B_{22}^c}{A_{11}^c}, & s_7 &= \frac{D_{11}^c}{A_{11}^c}, \\
s_8 &= \frac{D_{12}^c}{A_{11}^c}, & s_9 &= \frac{D_{22}^c}{A_{11}^c}, & s_{10} &= \frac{A_{66}^c}{A_{11}^c}, & s_{11} &= \frac{B_{66}^c}{A_{11}^c}, & s_{12} &= \frac{D_{66}^c}{A_{11}^c}, \\
\lambda'^2 &= \frac{R_0 \omega^2}{A_{11}^c} \quad \text{is a frequency parameter,} \\
R_0 &= \sum_k \rho^{(k)} [z_k(0) - z_{k-1}(0)] = \sum_k \rho_k h_k(0) \quad \text{is the inertial coefficient,}
\end{aligned} \tag{A.2}$$

and A_{ij}^c , B_{ij}^c , and D_{ij}^c are the elastic coefficients of constant thickness, which are extensional rigidities, the bending-stretching coupling rigidities and the bending rigidities, respectively.

B. The operators L_{3j} ($j = 1, 2, 3$) are:

The differential operators L_{31}^* , L_{32}^* , and L_{33}^* appearing in (3.1) are

$$\begin{aligned}
L_{31}^* &= s_4 \frac{g'}{g} \frac{d^2}{dx^2} + \left[s_4 \left(\frac{g'^2}{g^2} + s_{10} \frac{n^2}{r^2} \right) - \frac{s_2}{r} - \frac{n^2}{r^2} (s_5 + 2s_{11}) - \lambda'^2 s_4 \right] \frac{d}{dx} - 2s_{11} \frac{g'}{g} \frac{n^2}{r^2}, \\
L_{32}^* &= \frac{n}{r} \left[s_5 + 2s_{11} + \frac{1}{r} (s_8 + 2s_{12}) - s_4 \left(s_2 + s_{10} + \frac{1}{r} (s_5 + s_{11}) \right) \right] \frac{d^2}{dx^2} \\
&\quad + \frac{n}{r} \frac{g'}{g} \left[2 \left(s_5 + s_{11} + \frac{s_8}{r} + \frac{s_{12}}{r} \right) - s_4 \left(s_2 + \frac{s_5}{r} \right) \right] \frac{d}{dx} \\
&\quad - \frac{n}{r} \left[\frac{n^2}{r^2} \left(s_6 + \frac{s_9}{r} \right) + \frac{s_3}{r} + \frac{s_6}{r^2} - s_5 \frac{g''}{g} - \frac{s_8}{r} \frac{g''}{g} + s_4 \left(s_2 + \frac{s_5}{r} \right) \left(\frac{g''}{g} - \frac{g'^2}{g^2} \right) \right], \\
L_{33}^* &= (s_4^2 - s_7) \frac{d^4}{dx^4} + (s_4^2 - 2s_7) \frac{g'}{g} \frac{d^3}{dx^3} \\
&\quad + \left[\frac{2s_5}{r} - s_7 \frac{g''}{g} + \frac{n^2}{r^2} (4s_{12} + 2s_8) - s_4 \left\{ \frac{n^2}{r^2} (s_5 + 2s_{11}) + \frac{s_2}{r} - s_4 \left(\frac{g''}{g} - \frac{g'^2}{g^2} \right) \right\} \right] \frac{d^2}{dx^2} \\
&\quad + \frac{g'}{g} \left[\frac{2s_5}{r} + \frac{2n^2}{r^2} (2s_{12} + s_8) - s_4 \left(s_5 \frac{n^2}{r^2} + \frac{s_2}{r} \right) \right] \frac{d}{dx} \\
&\quad - \left[\frac{n^2}{r^2} \left(\frac{2s_6}{r} - s_8 \frac{g''}{g} \right) + \frac{n^4}{r^4} s_9 + \frac{s_3}{r^2} - \frac{s_5}{r} \frac{g''}{g} + s_4 \left(s_5 \frac{n^2}{r^2} + \frac{s_2}{r} \right) \left(\frac{g''}{g} - \frac{g'^2}{g^2} \right) \right] + \lambda'^2.
\end{aligned} \tag{B.1}$$

Acknowledgment

This work was supported by Inha University Research grant.

References

- [1] E. H. Baker and G. Herrmann, "Vibrations of orthotropic cylindrical sandwich shells under initial stress," *AIAA Journal*, vol. 29, pp. 963–975, 1966.
- [2] K. R. Sivasdas and N. Ganesan, "Free vibration of circular cylindrical shells with axially varying thickness," *Journal of Sound and Vibration*, vol. 147, no. 1, pp. 73–85, 1991.
- [3] R. F. Tonin and D. A. Bies, "Free vibration of circular cylinders of variable thickness," *Journal of Sound and Vibration*, vol. 62, no. 2, pp. 165–180, 1979.
- [4] S. Takahashi, K. Suzuki, T. Kosawada, and E. Anzai, "Vibration of cylindrical shells with variable thickness," *Bulletin of Japan Society of Mechanical Engineers*, vol. 24, pp. 1826–1836, 1981.
- [5] K. Suzuki, E. Anzai, and S. Takahashi, "Vibration of cylindrical shells with varying thickness," *Bulletin of Japan Society of Mechanical Engineers*, vol. 25, pp. 1108–1119, 1982.
- [6] K. R. Sivasdas and N. Ganesan, "Axisymmetric vibration analysis of thick cylindrical shell with variable thickness," *Journal of Sound and Vibration*, vol. 160, no. 3, pp. 387–400, 1993.
- [7] E. Hinton, M. Özakça, and N. V. R. Rao, "Free vibration analysis and shape optimization of variable thickness plates, prismatic folded plates and curved shells. Part 1: finite strip formulation," *Journal of Sound and Vibration*, vol. 181, no. 4, pp. 553–566, 1995.
- [8] G. Sun, P. N. Bennett, and F. W. Williams, "An investigation on fundamental frequencies of laminated circular cylinders given by shear deformable finite elements," *Journal of Sound and Vibration*, vol. 205, no. 3, pp. 265–273, 1997.
- [9] X. M. Zhang, "Vibration analysis of cross-ply laminated composite cylindrical shells using the wave propagation approach," *Applied Acoustics*, vol. 62, no. 11, pp. 1221–1228, 2001.
- [10] W. Hufenbach, C. Holste, and L. Kroll, "Vibration and damping behaviour of multi-layered composite cylindrical shells," *Composite Structures*, vol. 58, no. 1, pp. 165–174, 2002.
- [11] T. Sakiyama, X. X. Hu, H. Matsuda, and C. Morita, "Vibration of twisted and curved cylindrical panels with variable thickness," *Journal of Sound and Vibration*, vol. 254, no. 3, pp. 481–502, 2002.
- [12] T. Tsuiji and T. Sueoka, "Free vibrations of twisted thin cylindrical panels (numerical analysis by using the Rayleigh-Ritz method)," *Transactions of the Japan Society of Mechanical Engineers, Part C*, vol. 55, no. 514, pp. 1325–1329, 1989.
- [13] S. Tizzi, "A Ritz procedure for optimisation of cylindrical shells, formed by a nearly symmetric and balanced angle-ply composite laminate, with fixed minimum frequency," *Computers & Structures*, vol. 84, no. 31-32, pp. 2159–2173, 2006.
- [14] M. H. Toorani and A. A. Lakis, "Free vibrations of non-uniform composite cylindrical shells," *Nuclear Engineering and Design*, vol. 236, no. 17, pp. 1748–1758, 2006.
- [15] T. Mizusawa and H. Kito, "Vibration of cross-ply laminated cylindrical panels by the spline strip method," *Computers and Structures*, vol. 57, no. 2, pp. 253–265, 1995.
- [16] W. G. Bickley, "Piecewise cubic interpolation and two-point boundary problems," *Computer Journal*, vol. 11, pp. 206–208, 1968.
- [17] K. K. Viswanathan and P. V. Navaneethakrishnan, "Free vibration study of layered cylindrical shells by collocation with splines," *Journal of Sound and Vibration*, vol. 260, no. 5, pp. 807–827, 2003.
- [18] K. K. Viswanathan and K. S. Kim, "Free vibration of antisymmetric angle-ply-laminated plates including transverse shear deformation: spline method," *International Journal of Mechanical Sciences*, vol. 50, no. 10-11, pp. 1476–1485, 2008.
- [19] K. K. Viswanathan, K. S. Kim, J. H. Lee, H. S. Koh, and J. B. Lee, "Free vibration of multi-layered circular cylindrical shell with cross-ply walls, including shear deformation by using spline function method," *Journal of Mechanical Science and Technology*, vol. 22, no. 11, pp. 2062–2075, 2008.
- [20] S. A. Ambartsumyan, "Theory of anisotropic shells," Tech. Rep. NASA TTF-118, 1964.



Hindawi

Submit your manuscripts at
<http://www.hindawi.com>

