

# Frequency response based multivariable control design for motion systems

**Citation for published version (APA):**

Boerlage, M. L. G., Steinbuch, M., & Angelis, G. Z. (2005). Frequency response based multivariable control design for motion systems. In *Proceedings of the 2005 IEEE Conference on Control Applications (CCA 2005), 28-31 August 2005, Toronto, Canada* (pp. .-). Institute of Electrical and Electronics Engineers. <https://doi.org/10.1109/CCA.2005.1507257>

**DOI:**

[10.1109/CCA.2005.1507257](https://doi.org/10.1109/CCA.2005.1507257)

**Document status and date:**

Published: 01/01/2005

**Document Version:**

Accepted manuscript including changes made at the peer-review stage

**Please check the document version of this publication:**

- A submitted manuscript is the version of the article upon submission and before peer-review. There can be important differences between the submitted version and the official published version of record. People interested in the research are advised to contact the author for the final version of the publication, or visit the DOI to the publisher's website.
- The final author version and the galley proof are versions of the publication after peer review.
- The final published version features the final layout of the paper including the volume, issue and page numbers.

[Link to publication](#)

**General rights**

Copyright and moral rights for the publications made accessible in the public portal are retained by the authors and/or other copyright owners and it is a condition of accessing publications that users recognise and abide by the legal requirements associated with these rights.

- Users may download and print one copy of any publication from the public portal for the purpose of private study or research.
- You may not further distribute the material or use it for any profit-making activity or commercial gain
- You may freely distribute the URL identifying the publication in the public portal.

If the publication is distributed under the terms of Article 25fa of the Dutch Copyright Act, indicated by the "Taverne" license above, please follow below link for the End User Agreement:

[www.tue.nl/taverne](http://www.tue.nl/taverne)

**Take down policy**

If you believe that this document breaches copyright please contact us at:

[openaccess@tue.nl](mailto:openaccess@tue.nl)

providing details and we will investigate your claim.

# Frequency response based multivariable control design for motion systems

Matthijs Boerlage\*, Maarten Steinbuch \*, Georgo Angelis\*\*

**Abstract**—In this paper, we discuss the design of multivariable motion controllers exploiting crosscouplings in the controller for open loop decoupling, disturbance rejection and feedforward decoupling. Using specific properties of motion systems, we illustrate that frequency response design methods can be extended to handle several multivariable control problems. Application to high performance motion systems shows significant improvement.

## I. INTRODUCTION

Multivariable electro-mechanical motion systems are common practice in today's industry. Typical applications are XY-stages, vibration isolation platforms, robotics and many master-slave positioning devices. As modern control software offers the possibility to implement multivariable controllers and specifications become tighter, industry has a desire to exploit multivariable control design freedom where possible.

In control design for SISO electromechanical servo systems, loopshaping in the frequency domain is a well proven methodology as straightforward relations between open loop and closed loop responses hold [18]. This allows for clear interpretation of the physical properties of the control problem. It is well known that in the general MIMO control problem, there are no one-to-one relations between the terms of the multivariable controller and the resulting closed loop transfer. A  $n \times n$  square control problem, then results in a control problem with  $n^2$  highly interacting control terms. Also, design for stability (as governed by the generalized Nyquist criterium, [16]) and design for performance (in terms of principal gains) need not necessarily be expressed in the same framework.

Industrial solutions to handle multivariable control problems build strongly on reducing the MIMO problem to a set of independent (decoupled) SISO control problems. SISO control design techniques are then facilitated. A typical procedure for multivariable control design for electromechanical servo systems is as follows:

- 1) Identification
- 2) Interaction analysis
- 3) Static decoupling
- 4) Interaction analysis
- 5) Multiloop SISO control

\* Eindhoven University of Technology Faculty of Mechanical Engineering, Control Systems Technology Group P.O. Box 513, 5600 MB Eindhoven, The Netherlands Email: m.l.g.boerlage@tue.nl, m.steinbuch@tue.nl

\*\* Philips Applied Technologies, Mechatronics Technologies, Acoustics & Control, SAQ-2122 P.O. Box 218, 5600 MD Eindhoven, The Netherlands Email: georgo.angelis@philips.com

where parts of the procedure are iterated until specifications are met.

In Step 1, frequency response measurements of several loop transfers are obtained to derive the frequency response functions (FRFs) of the plant. Subsequently Step 2 is undertaken to study interaction and possibly study the possibility to reduce the general control problem to a subset which is smaller. The *relative gain array* (RGA), evaluated per frequency, is very useful for this application as the RGA is a measure for two-sided interaction and has the powerful property that it is scaling independent [4],[17]. Other measures, as the *measure of skewness* [10] or the *interaction number* [17], may also prove useful. When interaction is present, static decoupling techniques can be used to decouple (parts of) the control problem, Step 3. Numerical decoupling procedures can be applied, although procedures preserving physical insight (e.g. modal decoupling) are often preferred. When interaction has been reduced, decentralized control or sequential loop closing is used (Step 5) [13],[17]. Note that in all the steps sketched above, no model is required other than the frequency response measurements. Also, all design steps only focus on interaction of the plant and do not take in to account interaction of disturbances.

If one of the steps sketched above fails, specifications may not be met. Industry often has no other choice then to apply norm based control design techniques as  $H_2$ ,  $H_\infty$  and  $\mu$ -synthesis for more advanced multivariable control. Usage of these techniques requires detailed models, controller/model reduction and therefore has large implications for industrial usage. Implementation can be cumbersome, especially because resulting controllers are difficult to interpret and understand. Hence, further fine tuning during experiments is not possible, yet preferred by industrial control engineers. One line of research is to combine model-based and classical loopshaping ideas such as QFT [9] into one design paradigm as described in [12] and used in [5].

We show that for many (electro) mechanical systems, multivariable control design freedom is maximally exploited using the design steps 1 – 5 sketched above. We present two methods to handle interaction that are not captured in this design procedure. In both cases physical insight is preserved and it is not necessary to rely on norm based control design techniques. All techniques have been tested on industrial applications. A common two degrees of freedom industrial

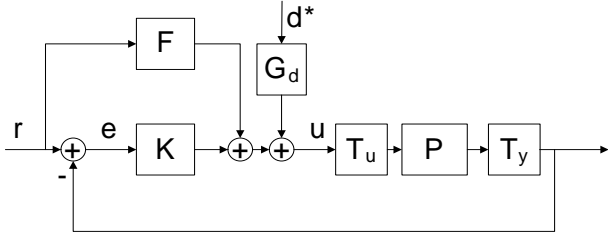

Fig. 1. Multivariable control configuration used in this work.

control architecture is depicted in Figure 1. Herein,  $P$  denotes the plant with possible input  $T_u$  and output  $T_y$  transformations. The feedback controller and feedforward controller are denoted by  $K$  and  $F$  respectively. The disturbance model is denoted by  $G_d$ . Signals of interest are the servo error  $e$ , the plant input  $u$ , the disturbance source signal  $d^*$  and the reference trajectory  $r$ .

In Section II, we will first show how to find  $T_u$  and  $T_y$  using frequency response data only. Then, using the same data, we show how to improve performance by using a multivariable feedforward controller. Finally, in Section IV we will discuss the disturbance directionality problem. Throughout the work, we consider square plants only.

## II. DECOUPLING ELECTROMECHANICAL MOTION SYSTEMS

In this section, we discuss the design of the input/output transformations  $T_u, T_y$  which are used to decouple the open loop transfer function. When the open loop transfer function is decoupled, the  $n \times n$  MIMO control problem reduces to  $n$  independent SISO control problems. We focus on electro-mechanical motion systems where dynamics are dominated by mechanics and flexible modes result from limited mechanical stiffness which we assume proportionally damped. The dynamics can be described as a sum of second order modal contributions;

$$P(s) = \underbrace{\sum_{j=1}^{N_{rb}} \frac{u_j^T v_j}{s^2}}_{\text{rigid body}} + \underbrace{\sum_{i=N_{rb}+1}^N \frac{u_i^T v_i}{(s^2 + 2\zeta_i \omega_i s + \omega_i^2)}}_{\text{flexible body}} \quad (1)$$

Where  $N_{rb}$  denotes the number of rigid body modes,  $N - N_{rb}$  are the number of flexible modes with resonance frequency  $\omega_i$  and relative damping  $\zeta_i$ . The corresponding eigenvectors are denoted by  $u_i, v_i$ . A different notation of (1) is;

$$P(s) = \frac{1}{s^2} P_{rb} + P_{flex}(s) \quad (2)$$

Where  $P_{rb}$  is a constant matrix. Since we only discuss square plants, the number of inputs (actuators) equals the number of outputs (sensors). Hence,  $P_{rb}, P_{flex}(s)$  are square. When modes are both controllable and observable, modes can be perfectly decoupled using input and output transformations. A system property that is closely related is the *dyadic*

property of systems [14]. A dyadic system, has the property that it can be transformed such that

$$P(s) = U \Sigma(s) V^T \quad (3)$$

where  $U, V$  are constant for all frequencies, but not necessarily unitary.  $\Sigma(s)$  is diagonal and its entries are SISO transfer functions. Decoupling is possible by using  $V^{-T}$  and  $U^{-1}$  as input ( $T_u$ ) and output ( $T_y$ ) transformations of the plant so that

$$P_{dec}(s) = U^{-1} P(s) (V^T)^{-1} \quad (4)$$

is diagonal and approximately equal to  $\Sigma(s)$ . In [2] it was shown that this is the case when modes can be both actuated and measured independently (hence when they are both observable and controllable).

We illustrate the application of dyadic decoupling by means of the belt drive system depicted in Figure 2. The

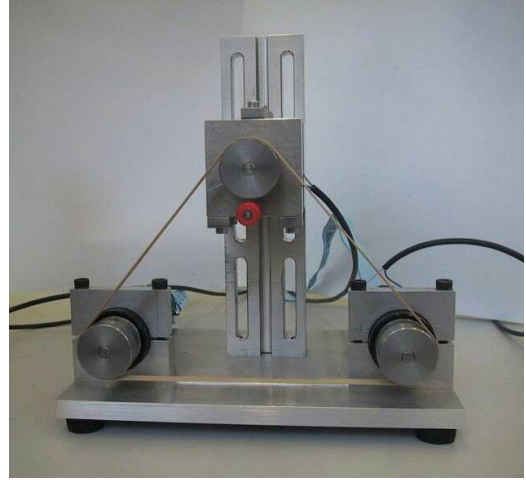

Fig. 2. MIMO belt drive system as used to illustrate dyadic and modal decoupling. Two rolls at the bottom of the system are used for actuation (DC motors) and position measurement (encoders).

system has two actuators and two sensors, at both sides of the flexibility. It is hence possible to isolate the flexible mode from the rigid body mode. We start controlling the system in the physical variables; that is, the motor current and the encoder signals. The frequency response in these coordinates is given in Figure 3. Next, we choose two points of the frequency response function ( $\omega_2 > \omega_1$ ) in the frequency band of interest. We now use [14],[19] to obtain,

$$\begin{aligned} P(j\omega_1) &= U \Sigma(j\omega_1) V^T \\ P(j\omega_2) &= U \Sigma(j\omega_2) V^T \\ P(j\omega_1) P(j\omega_2)^{-1} &= U \Sigma(j\omega_1) V^T V^{-T} \Sigma(j\omega_2)^{-1} U^{-1} \\ \rightarrow P(j\omega_1) P(j\omega_2)^{-1} U &= U \Sigma(j\omega_1) \Sigma(j\omega_2)^{-1}. \end{aligned}$$

Hence  $U$  can be found solving this eigenvalue problem.  $V$  can be determined in similar fashion. With this, no modal analysis is required to obtain partial modal decoupling. We obtain the following  $T_u, T_y$ :

$$T_u = \begin{bmatrix} 0.71 & 0.71 \\ 0.70 & -0.70 \end{bmatrix}, T_y = \begin{bmatrix} 0.71 & 0.70 \\ 0.71 & -0.70 \end{bmatrix} \quad (5)$$

We see that, except for some scaling, this equals the mode shapes of the system and we found the modal decoupling transformations using the dyadic property of this system. The frequency response function for the decoupled plant  $P_{dec} = T_y P T_u$  is also depicted in Figure 3 (labelled "DTM": thick line). We see that we can control the flexible mode and the rigid body mode independently, since off-diagonal terms are relatively low. Choosing a bandwidth greater than  $5\text{hz}$  results in increasing stiffness of the flexible mode. Hence, in more practical applications, structural design requirements can be relieved.

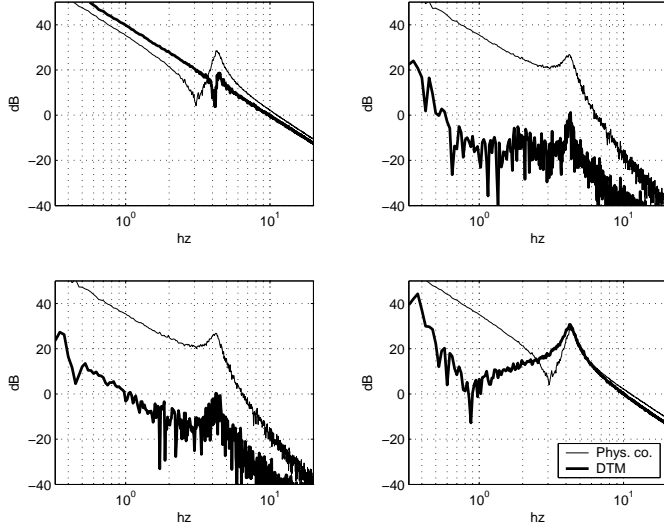

Fig. 3. Static decoupling of the belt drive system (thin in measured variable coordinates,  $P(j\omega)$ ), using Dyadic transformation matrix (DTM, solid,  $P_{dec}(j\omega)$ )

### III. MULTIVARIABLE FEEDFORWARD

In many tracking control applications, the reference trajectory can be considered as the largest disturbance in the controlled system. Using feedforward control, most of the tracking performance of industrial systems is obtained. The feedforward controller can not affect stability of the closed loop system as long as the feedforward controller itself is stable. This creates design freedom in decoupling especially in the case where perfect decoupling is not allowed in feedback (e.g. leads to unstable feedback controller). The following case illustrates how dynamic decoupling of the plant can be contained in feedforward control. We also present a new result for feedforward design. We study tracking of an industrial XY-manipulator, see Figure 4 and [20]. Each of the six degrees of freedom is controlled and we study the  $z$  and the  $R_z$  axis. This plant has the same number of actuators and sensors as rigid body modes and is decoupled in the coordinates of the rigid body modes. In that case, flexible modes can not be controlled independently as in Section II. As the rigid body modes are dominant over the flexible modes, in the region of the bandwidth, the open loop is diagonal dominant [16] and the system can be robustly stabilized with a diagonal feedback controller. For

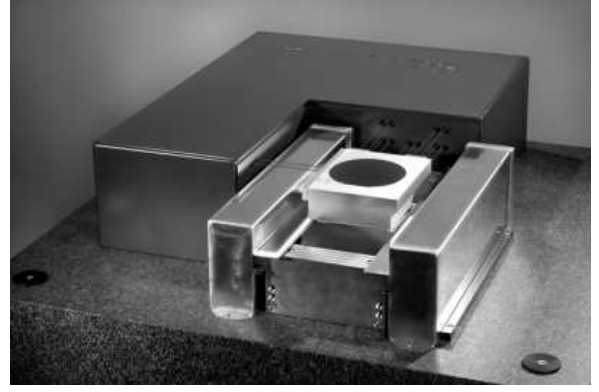

Fig. 4. An example industrial XY-manipulator controlled in six degrees of freedom.

decoupling, only an actuator transformation  $T_u = P_{rb}^{-1}$ ;  $T_y = I$  is required. The plant 'as seen' by the feedback controller now equals;

$$P(s)T_u = \frac{1}{s^2}I + P_{flex}(s)P_{rb}^{-1}. \quad (6)$$

It is visible that the flexible modes are still not decoupled when  $P_{flex}(s)P_{rb}^{-1}$  is not diagonal. Low frequency tracking errors (cross-coupling) occur due to these non-diagonal terms in the open loop. As these tracking errors are directly related to the reference trajectory, multivariable feedforward control is considered.

The objective is to let this plant track reference profiles with high accelerations and jerks, typically step and scanning profiles. In these cases, the energy of the reference profile is high in low frequencies and a significant factor (100dB) lower for frequencies around and above the resonance frequencies of the flexible modes. When only low frequency behavior is of interest for feedforward design, it is not the best choice to approximate the plant only with the first term in Equation 6, which is mostly done. As a new result we consider a plant model where the low frequency contribution of flexible modes is described with a matrix of real values, the residual stiffness matrix:

$$P_{flex}(s)P_{rb}^{-1}|_{s \rightarrow 0} \approx \tilde{P}, \quad \tilde{P} \in \mathbb{R}^{n \times n}. \quad (7)$$

Therefore, the plant in rigid body coordinates is now modeled as:

$$P^*(s) = P(s)T_u = \frac{1}{s^2}I + \tilde{P} \quad (8)$$

With the design of the feedforward controller, the transfer between the servo error  $e$  and the reference trajectory  $r$  is to be minimized. This transfer is easily derived from Figure 1 leading to:

$$e = S_o(I - P^*F)r \quad (9)$$

where  $S_o$  is the output sensitivity  $S_o = (I + P^*K)^{-1}$ ,  $K$  is the feedback controller and  $F$  is the feedforward controller. In order to reduce this transfer function, we design the feedforward controller to be the inverse of the plant

$F = P^{*-1}$  which we require to be exact at  $s = 0$ . Using the Taylor expansion at  $s = 0$  we find the following;

$$\begin{aligned} F &= \left(\frac{1}{s^2}I + \tilde{P}\right)^{-1} = (I + s^2\tilde{P})^{-1}s^2 \\ F &= s^2I - s^4\tilde{P} + \mathcal{O}(6) \end{aligned} \quad (10)$$

We recognize acceleration feedforward (terms of  $s^2$ ) and a *jerk derivative feedforward controller* (terms of  $s^4$ ). A SISO controller of this fashion was derived in [3] and [11]. Note that only the jerk derivative term contains interaction. Hence, we have isolated dynamic decoupling from the reference trajectory to the servo error in only one block which can be tuned independently from acceleration feedforward. Hence it is possible to (re)tune the feedforward controller online, monitoring the servo error in the time domain. In Figure 5, simulation results for the industrial XY manipulator with only acceleration feedforward  $F(s) = s^2I$  are shown. Using the multivariable feedforward controller, following (10), results in reduction of cross-coupling and significantly improved low frequency tracking performance, see Figure 6 (different scale!). The residual tracking errors are caused as resonance dynamics are excited with little remaining energy at high frequencies. This is because the (multivariable) jerk derivative feedforward controller only compensates for low frequency modal contributions and does not invert high frequency resonance dynamics.

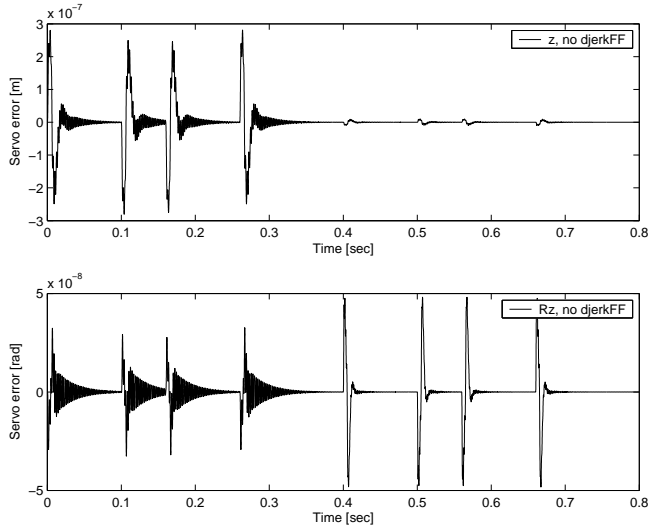

Fig. 5. Servo error in  $z$  axis (top) and  $R_z$  axis (bottom) during motion in  $z$  axis and  $R_z$  axis subsequently using acceleration feedforward only. Due to low frequency modal contributions, tracking errors appear during jerk phases of a motion. As these modal contributions are coupled, cross-talk occurs.

#### IV. DISTURBANCE DECOUPLING

When the open loop is perfectly decoupled, there may still be a need to introduce coupling in the feedback controller. Often disturbances are highly coupled as they relate to the same underlying physical process, e.g. floor vibrations, pumps, reaction forces on metrology frames,

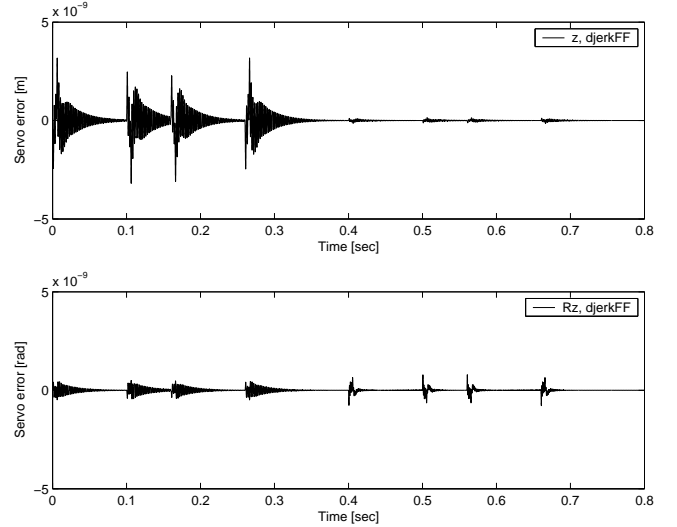

Fig. 6. Servo error during motion in  $z$  axis and  $R_z$  axis subsequently using acceleration and MIMO jerk derivative feedforward. The coupled low frequency modal contributions are compensated, resulting in a significant reduction of the tracking error and cross-talk.

etc. [1]. A multivariable property of these disturbances is that they have a fixed *direction*, the ratio in which they are distributed among controlled variables. The direction of the disturbance can then be incorporated in multivariable control design.

Use of interaction of disturbance models goes back to the work of [21]. In the work of [15], interaction in the multivariable controller was found to be very beneficial because of strong coupling of disturbances. Here, we combine the two methods and use multivariable control design freedom to decouple the disturbance model. Hence, interaction is created in the open loop transfer function, which contradicts diagonalizing design approaches as that of [16].

An example of this is the problem where two disturbances originate from the same source and excite two decoupled loops. When the direction of the disturbance vector (the ratio between the disturbances) is fixed, a single off-diagonal term may be introduced in the controller to cancel the disturbance in one of the loops. Consider a linear time invariant disturbance model  $G_d$  as follows;

$$\underbrace{\begin{bmatrix} d_1 \\ d_2 \end{bmatrix}}_{d_i} = \underbrace{\begin{bmatrix} 1 & 0 \\ \alpha & 1 \end{bmatrix}}_{G_d} \underbrace{\begin{bmatrix} d \\ 0 \end{bmatrix}}_{d^*} \quad (11)$$

So that the disturbance source  $d^*$  is mixed with a linear time invariant system  $G_d$ . We assume that the directionality (the ratio in which the disturbance source is distributed among the control loops) is fixed and known. Off-diagonal control terms in  $K$  can be used to take advantage of this. The controller for this situation is the product of a diagonal frequency dependent controller  $K_d$  and a static transformation  $K^*$  yet

to be determined. So that

$$K(s) = K^* K_d(s). \quad (12)$$

We use the relation between the closed loop servo error  $e$  and the input disturbance source to design  $K^*$ . Here, we make use of the fact that at low frequencies the high gain property holds ( $PK \gg I$ ) and we assume invertible plant data;

$$\begin{aligned} e &= S_o P G_d d^* \\ &= (I + PK^* K)^{-1} P G_d d^* \\ &\approx (PK^* K)^{-1} P G_d d^* = K^{-1} (K^*)^{-1} G_d d^* \end{aligned}$$

Therefore, choosing  $K^* = G_d$ , directly decouples the disturbance model. We restrict ourselves to triangular  $K^*$  so that interaction in the open loop can not change the characteristic gain loci (hence stability) of the controlled system. In fact, this one sided interaction, can be seen as *disturbance feedforward* from one loop to the other, where the disturbance is "measured" in the  $k_{11}p_{11}$  loop, see Figure 7. Hence, when the disturbance direction is not equal to

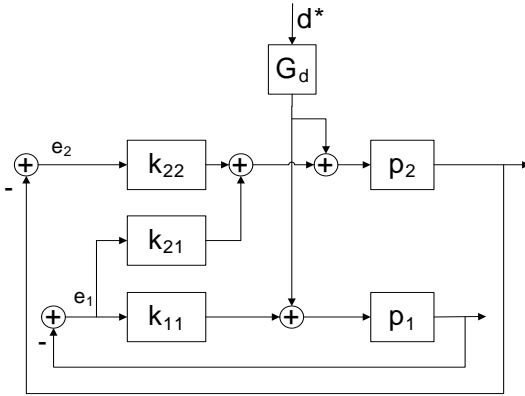

Fig. 7. Disturbance decoupling control using triangular  $K^*$  in the two by two case equals disturbance feedforward from one loop to the other.

that of the model, performance may be worse than in the case of  $K^* = I$ .

An industrial example, closely resembling that of Section III, was studied where all (decoupled) controlled axes suffer from the same 24 Hz floor disturbance. The decoupled axes are regulated with a diagonal controller, resulting in a bandwidth of 150 Hz. The source of the disturbance is machinery operating in a neighboring factory, which leads to harmonic floor vibrations of exactly 24 Hz. The fixed direction was determined using disturbance identification techniques [8]. Using the triangular disturbance decoupling control technique resulted in a factor 2 reduction of the servo error at 24 Hz, see Figure 8. Note that herein, solely multivariable control design freedom is used. Hence, there are no associated SISO costs using this technique.

## V. CONCLUSIONS

In this paper, three techniques are presented showing how to exploit multivariable control design freedom. It

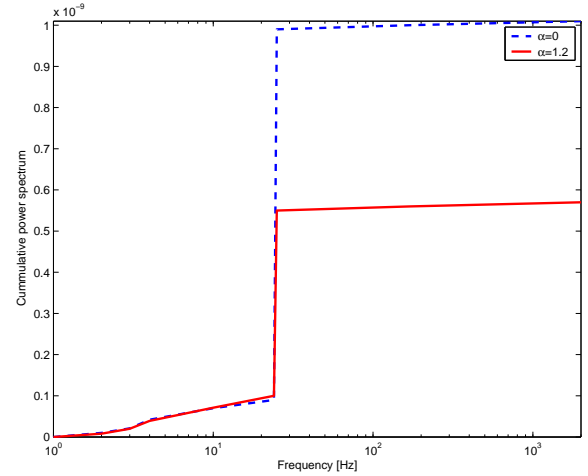

Fig. 8. Cumulative power spectrum (CPS) of the servo error in  $p_2$ -axis with ( $\alpha = 1.2$ ) and without ( $\alpha = 0$ ) disturbance decoupling control.

is illustrated how bandwidth limitations due to flexible modes can be eliminated with the use of decoupling control. Instead of using modal control techniques, results of dyadic control system theory can directly be applied to achieve this. Possible independent control of flexible modes stresses the need to exploit synergy between system design and control.

When only rigid body decoupling is possible, flexible mode contributions, resulting in cross-coupling, can be reduced using multivariable feedforward design. Here, a multivariable extension of jerk derivative feedforward is used which decouples the transfer from reference trajectories to the servo error. Also, an example is given where interaction in the open loop may result in improved disturbance control. With a fixed disturbance direction, it is demonstrated that multivariable control design freedom can be exploited. Hence it is demonstrated that diagonalizing the open loop transfer function may not always lead to the best control design. The question rises how interaction in disturbance models can be compared with interaction of plant dynamics as both models may require a different decoupling technique. Development of tools to quantify this, is subject for future research.

It is important to develop more insight in the possibilities of multivariable control and what can be achieved using this kind of additional design freedom. Examples of industrial multivariable control play an important role in justifying application other than decentralized control in industrial practice. Herein, it is important not to underestimate the necessity of physical insight in control problems. Therefore, tools may be developed to assist the control designer in choosing a specific control structure in multivariable design. With this, physical interpretation can be preserved while, gradually, more multivariable control design freedom can be used. Future research will focus on this.

## REFERENCES

- [1] D. Abramovitch, T. Hurst, D. Henze, 'An Overview of the PES Pareto Method for Decomposing Baseline Noise Sources in Hard Disk Position Error Signals', *IEEE Transactions on Magnetics*, Vol. 34, No. 1, 1998 pp. 17-23.
- [2] J. Anthonis, H. Ramon, 'Linear mechanical systems and dyadic transfer function matrices', *Automatica*, Vol. 39, pp. 1353-1363, 2003.
- [3] M. Boerlage, R. Tousain, M. Steinbuch, 'Jerk derivative feedforward control for motion systems', *Proceedings of the American Control Conference*, 2004, pp. 4843-4848.
- [4] E. Bristol, 'On a new measure of interactions for multivariable process control', *IEEE Transactions on Automatic Control*, ACC-11, 1966, pp.133-134.
- [5] R. Draï, M. Steinbuch, D. Hoekstra, S. Salehi, 'Robust QFT/Hinf Attitude Control of a Small Solar Thermal Transfer Vehicle', *Proceedings of the 16th IFAC Symposium on Automatic Control in Aerospace*, 6p. 2004.
- [6] J. Edmunds, B. Kouvaritakis, 'Extensions of the frame alignment technique and their use in the characteristic locus design method', *International Journal of Control*, 1979, Vol. 29, No. 5, pp.787-796.
- [7] W. Gawronski, 'Advanced Structural Dynamics and Active Control of Structures', Springer-Verlag, 2004.
- [8] H. Hindi, 'Identification of Power Spectra from Frequency Domain Data and Disturbance Models in Control Systems', *Technical report*, <http://www.parc.com/hhindi/reports/DiskSpecID.pdf>, 2000.
- [9] I. Horowitz, 'Survey of quantitative feedback theory (QFT)', *International Journal of Robust and Nonlinear Control*, Vol 11, pp. 887-921, 2001.
- [10] Y.S. Hung, A. MacFarlane, 'Multivariable feedback: A Quasi-Classical Approach', *Lecture notes in control and information sciences*, Vol. 40, Springer-Verlag, 1982.
- [11] P. Lambrechts, M. Boerlage, M. Steinbuch, 'Trajectory planning and feedforward design for electromechanical motion systems', *Control Engineering Practice*, 13(2), 145-157, 2005.
- [12] J. Lee, Y. Chait, M. Steinbuch, 'On QFT tuning of multivariable mu controllers', *Automatica*, 36, 1701-1708, 2000.
- [13] J. Maciejowski, 'Multivariable feedback design', Addison-Wesley, 1989.
- [14] D. Owens, 'Feedback and multivariable systems', Peter Peregrinus Ltd., 1978.
- [15] J. Pukrushpan, et. al., 'Control of Natural Gas Catalytic Partial Oxidation for Hydrogen Generation in Fuel Cell Applications', *IEEE Control Systems Technology*, 13(1), 3-14, 2005.
- [16] H. Rosenbrock, 'Computer-aided control system design', Academic Press, 1974.
- [17] S. Skogestad, I. Postlethwaite, 'Multivariable feedback control, analysis and design', John Wiley & Sons, 1996.
- [18] M. Steinbuch, M.L.Norg, 'Advanced motion control: an industrial perspective', *European Journal of Control*, 1998, pp.278-293.
- [19] D. Vaes, J. Swevers, P. Sas, 'Optimal decoupling for MIMO-controller design with robust performance', *Proceedings of the American Control Conference*, 2004, pp. 4601-4606.
- [20] M. van de Wal, G. van Baars, F. Sperling, O. Bosgra, 'Multivariable  $H_\infty / \mu$  feedback control design for high-precision wafer stage motion', *Control Engineering Practice*, Vol. 10, pp. 739-755, 2002.
- [21] W. Wonham, 'Linear multivariable control: A geometric approach', Springer-Verlag, 1979.