

Frequency-Selective Homodyne Coherent Receiver with an Optical Injection Phase Lock Loop

M. J. Fice and A. J. Seeds

Department of Electronic and Electrical Engineering, University College London, Torrington Place, London, WC1E 7JE, United Kingdom.

Email: m.fice@ee.ucl.ac.uk, a.seeds@ee.ucl.ac.uk

Abstract: The first homodyne coherent receiver with optical injection phase lock loop is reported, achieving phase-error variance of $5 \times 10^{-3} \text{rad}^2$ (1.5MHz linewidth). 10Gb/s ASK data was demodulated with $\text{BER} < 10^{-9}$ with an equal-power interfering signal at 25GHz offset.

©2007 Optical Society of America

OCIS Codes: (060.1660) Coherent communications; (060.2920) Homodyning

1. Introduction

Agile optical networks will require rapidly tuneable frequency-selective receivers to enable fast reconfiguration and to select from broadcast channels. Coherent detection, used in conjunction with fast tuneable lasers, provides a suitable frequency selection mechanism. Channel selection has been demonstrated using heterodyne detection [1], but this requires wide bandwidth electronics and the channels must be relatively widely separated (by more than twice the intermediate frequency). A frequency-selective intradyne receiver has been demonstrated [2], but required analogue squarers to recover the ASK data, adding complexity to the data signal path. In these experiments, separation between the selected and interfering channels was 100 GHz or more. A digital coherent receiver [3] could also be used, but requires complex electronics which would add to power consumption.

Synchronous homodyne detection requires opto-electronic and electronic components with lower bandwidth than other coherent techniques, gives demodulation directly to the baseband without further processing, and allows closely spaced channels to be demultiplexed. However, an optical phase lock loop (OPLL) is required, which is difficult to implement using conventional approaches. One reason for this is the difficulty of achieving an OPLL with a low loop delay, which limits the loop bandwidth and thus imposes a constraint on the summed linewidth of the transmitter and local oscillator (LO) lasers. To achieve the low phase error variance required for a robust optical transmission system, lasers with linewidths of at most a few hundred kHz must be used, even assuming that loop delays of a few nanoseconds can be achieved [4].

The Optical Injection Phase Lock Loop (OIPLL) combines optical injection locking with low-bandwidth electronic feedback to give a low-delay, wide-bandwidth OPLL with large locking range [5]. It has been used in a rapidly tuneable source with switching time < 10 ns, demonstrating its suitability for agile applications [6]. In this paper we demonstrate, for the first time, a homodyne coherent optical receiver using an OIPLL, enabling the receiver LO to be phase locked to the transmitter laser with very low phase-error variance, even when lasers with summed linewidths of a few MHz are employed. Frequency-selectivity is demonstrated by demultiplexing and demodulating 10 Gb/s amplitude shift keyed (ASK) data with channel separation down to 17.5 GHz.

2. Experimental system

The experimental configuration used for demonstrating the OIPLL receiver is shown in Fig. 1.

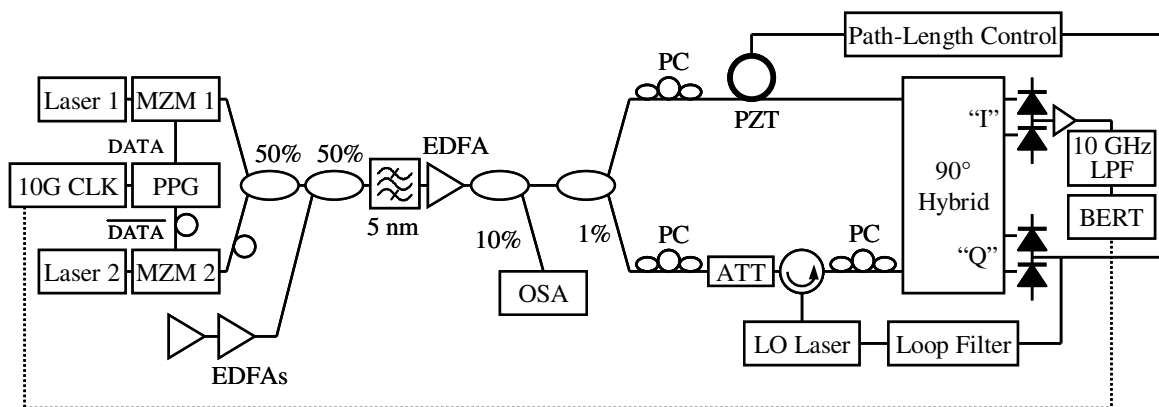

Fig. 1. Experimental arrangement

The outputs of two external cavity tunable lasers were intensity (binary ASK) modulated by a 10 Gb/s $2^{31}-1$ PRBS using Mach-Zehnder modulators and combined to form a 2-channel WDM signal. One channel, at 1566.34 nm, was the ‘wanted’ signal to be demultiplexed and demodulated by the coherent receiver, while the other channel provided an ‘interfering’ signal at a variable wavelength offset. The two channels were adjusted to be co-polarised and to have equal power at the input to the receiver. The WDM signal was noise loaded with variable levels of ASE noise from two EDFAs and passed through a 5 nm optical filter (representing a band filter).

In the receiver, a small portion of the input signal was tapped off and used to injection lock the LO laser. The input signal and LO were combined in a lithium niobate integrated optics 90° hybrid, one output of which gave the demodulated data (“I”), while the quadrature (“Q”) output gave a phase error signal that was passed through a loop filter and used to tune the frequency of the LO laser, thus forming an OPLL which ensured that the LO laser remained locked to the incoming signal. Changes in fibre path lengths in the input section of the receiver arising from thermal and other environmental changes were tracked by a low-bandwidth control loop driving a piezo-electric fibre stretcher (PZT).

The LO was a three-section DBR laser operated at an output power of approximately 9 dBm. Control of the LO laser frequency, required for signal acquisition and OPLL tracking, was performed via the gain section current. The LO laser was operated with the phase and grating sections un-biased, and the wavelength of the wanted channel was adjusted to match that of the LO laser, although in principle the grating and phase sections could be adjusted to select any wavelength within the tuning range of the LO laser. Injection locking to the wanted signal was achieved by injecting signal through the circulator into the LO laser at a power of approximately -34 dBm and manually adjusting the frequency difference between the two lasers. The optical injection locking range for these conditions was 0.5 GHz. Once the LO laser was locked, the automatic control loops were closed, giving a tracking range of around 30 GHz, limited only by the tuning range over which the LO power is sufficient for the receiver to operate.

Balanced photo-detectors, combined with careful adjustment of the splitting ratio of the output couplers of the optical hybrid, allowed a high common-mode rejection ratio to be obtained (≥ 25 dB), suppressing direct-detection signals and common-mode noise contributions. A phase shifter in the data signal arm of the optical hybrid was adjusted to give quadrature outputs. The excess loss of the optical hybrid (i.e. excluding the splitting losses in the couplers) was about 6 dB, so the input signal was boosted to 13 dBm per channel at the input to the receiver in order to achieve an adequate electrical signal to receiver noise ratio for data detection. Optical powers at the data path outputs of the hybrid were approximately -2 dBm for the data signal and -1 dBm for the local oscillator. Under these conditions, the coherent gain is small, so frequency selectivity is achieved through the high common-mode rejection of the receiver architecture. A higher power LO laser and/or lower hybrid loss would allow operation at a higher coherent gain and hence allow additional suppression of direct-detection signals.

3. Phase noise measurements

The locking performance of the OIPLL was assessed by measuring the phase error spectrum with a CW input (Fig. 2). Above 100 MHz, the spectrum rolls off as $1/f^2$, corresponding to untracked laser phase noise outside the injection locking bandwidth. Fitting the theoretical phase noise spectrum for a Lorentzian linewidth to this section of the experimental spectrum (shown dashed) gives an estimate of the combined linewidth of transmitter and LO lasers as around 1.5 MHz, dominated by the LO laser (the transmitter laser has a specified linewidth of 100 kHz).

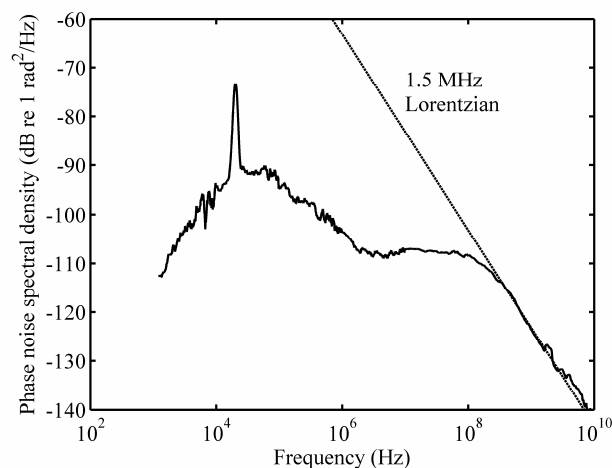

Fig.2. Phase error spectrum with receiver locked to CW input

At frequencies below a few hundred MHz, the measured phase noise is considerably lower than the theoretical spectrum, showing that the lasers are phase locked. Below 1 MHz, noise and the low frequency roll-off of the RF amplifier dominate. The strong peak at 20 kHz is a dither signal used for the path-length control loop. The integral of the phase noise spectrum over the frequency range 1 kHz to 10 GHz gives a phase error variance of $5 \times 10^{-3} \text{ rad}^2$.

4. Data demultiplexing and demodulation

The ASK data is demodulated directly to the baseband when the OIPLL is in lock. BER measurements as a function of OSNR are shown in Fig. 3 for demodulation of the wanted channel alone, and with the interfering channel at various channel separations. Operation with $\text{BER} < 10^{-9}$ was achieved for channel separations of 25 GHz and 50 GHz, with a penalty of less than 2 dB compared to single channel operation. For channel separations of 20 GHz and lower, an error floor was observed at high OSNR. The receiver remained in lock even when the OSNR was reduced to below 10 dB (0.1 nm noise bandwidth). The required OSNR for $\text{BER} = 10^{-3}$ was approximately 10.5 dB for single channel operation and with channel separations of 50 GHz and 25 GHz. At a channel separation of 17.5 GHz, the OSNR penalty for $\text{BER} = 10^{-3}$ was around 1.5 dB. These results suggest that demultiplexing of ultra-dense WDM channels should be possible if forward error correction techniques were applied.

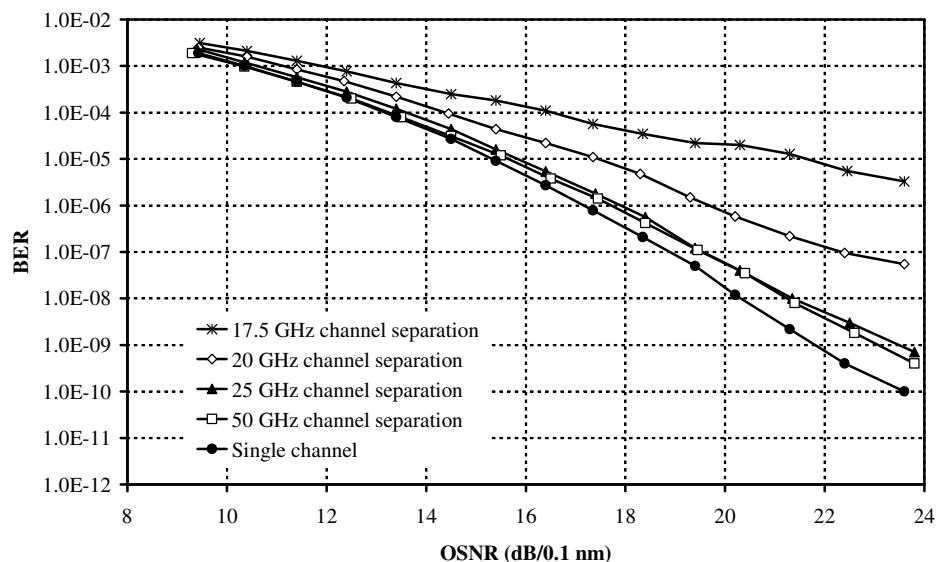

Fig.3. BER vs OSNR for various channel separations

5. Conclusions

A novel homodyne coherent optical receiver has been demonstrated that uses an optical injection phase lock loop, which combines optical injection locking with low-bandwidth electronic feedback to give a low-delay, wide-bandwidth OPLL. Demodulation direct to the baseband without additional processing gives a simpler, lower bandwidth data path than other coherent receiver architectures, and allows very closely spaced wavelength channels to be demultiplexed. Phase noise variance of $5 \times 10^{-3} \text{ rad}^2$ over the frequency range 1 kHz to 10 GHz was measured for a combined linewidth of 1.5 MHz. Frequency-selective operation was realised through the high common-mode rejection of the receiver architecture, enabling demodulation of 10 Gb/s ASK data (2^{31} -1 PRBS) to be achieved with a $\text{BER} < 10^{-9}$ in the presence of an equal-power interfering signal at frequency offsets ≥ 25 GHz. At a BER of 10^{-3} , the OSNR penalty due to the interfering channel was less than 1.5 dB for channel separations ≥ 17.5 GHz.

Acknowledgement

This work was funded by the European Office of Aerospace Research & Development.

References

1. L. Möller, M. Kauer, A. Adamiecki, J. Sinsky and L. Buhl, *Photonics Technol. Lett.*, 16(1), pp. 272–274, 2004.
2. P. J. Anslow, C. R. S. Fludger, S. Savory, I. Hardcastle and J. Fells, ECOC'06, vol. 1, pp. 61–62, paper Mo4.2.4.
3. M. G. Taylor, *IEEE Photonics Technol. Lett.*, 16(2), pp. 674–676, 2004.
4. R. T. Ramos and A. J. Seeds, *Electronics Lett.*, 26(6), pp. 389–391, 1990.
5. A. C. Bordonalli, C. Walton, and A. J. Seeds, *J. Lightw. Technol.*, 17(2), pp. 328–342, 1999.
6. C. C. Renaud *et al.*, *Photonics Technol. Lett.*, 16(3), pp. 903–905, 2004.