

FUEL CONSUMPTION DUE TO SHAFT POWER OFF-TAKES FROM THE ENGINE

Dieter Scholz*¹, Ravinka Seresinhe², Ingo Staack³, Craig Lawson²

¹Aircraft Design and Systems Group (AERO)
Hamburg University of Applied Sciences
Berliner Tor 9, 20099 Hamburg, Germany

²Department of Aerospace Engineering, Cranfield University
College Road, Cranfield, Bedfordshire, MK43 0AL, England

³Division of Fluid and Mechatronic Systems, Linköping University
581 83 Linköping, Sweden

info@ProfScholz.de

The conference CD contains the 19-page long version of this paper!

Abstract

This paper looks at fuel consumption due to shaft power off-takes from the engine and the related increase in the aircraft's fuel consumption. It presents a review and comparison of published and unpublished data on this kind of consumption. The paper presents results from the TURBOMATCH engine simulation model, calibrated to real world engine data. A generic equation is derived for the calculation of fuel consumption due to shaft power extraction. Main result is the shaft power factor k_p found to be in the order of 0.002 N/W for a typical cruise flight. This yields an amazingly high efficiency for power generation by shaft power extraction from a turbo fan engine of more than 70 %.

1 INTRODUCTION

1.1 Trade-Offs

Many technical options exist for the design of an aircraft system under investigation. Safety aspects allow no compromise because certification regulations have to be closely followed. The best alternative is hence found from trade-off studies considering system price, maintainability, reliability, and the system's fuel consumption. An aircraft system consumes fuel due to transportation of the system's mass during flight (fixed or variable mass), shaft

power off-takes from the engines (by electrical generators or hydraulic pumps), bleed air off-takes (for the pneumatic system), ram air off-takes (e.g. cooling air for the air conditioning system), and additional aircraft drag caused by the presents of parts sticking out into the flow field (e.g. due to drain masts or antennas) [17]. This paper limits the investigation to considering fuel consumption due to shaft power off-takes from the engines.

1.2 Shaft Power from the Accessory Gearbox

Figure 1 shows the principle of how shaft power is taken from the high and/or low pressure shaft of the engine. Required is an internal gearbox that couples the engine shaft(s) to a radial driveshaft that drives an external accessory gearbox (AGB). Figure 1 shows further that bleed air is taken from the engine compressor. Note: Bleed air is not considered in this paper.

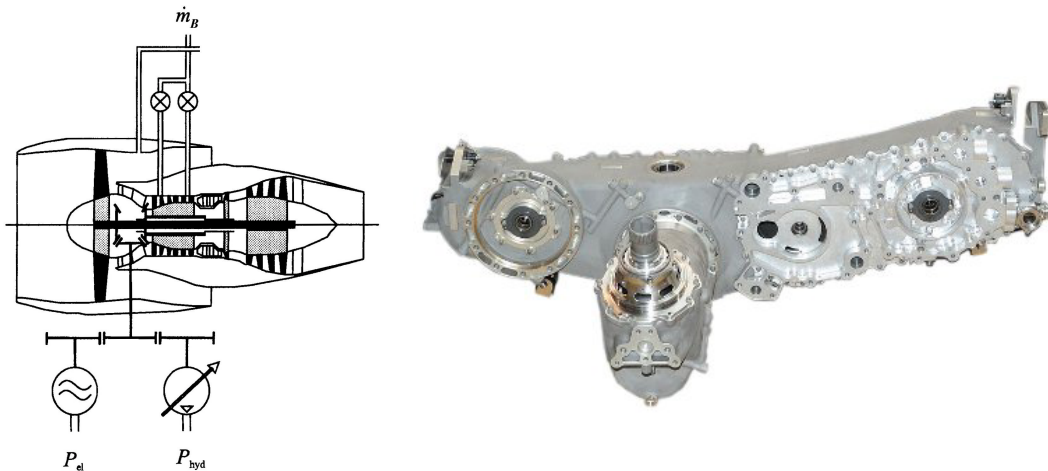

Figure 1(left) – Principle of bleed air off-takes and shaft power off-takes from the engine accessory gearbox [6], [3]

Figure 2 (right) – Hispano-Suiza accessory gearbox and power transmissions for the Rolls-Royce's Trent family of engines powering the Airbus A340-500/600, Airbus A330, and Boeing 777. Visible are the connection for the radial drive shaft and the mounting pads for the accessories [14]

The *internal gearbox* is usually located between the low pressure and the high pressure compressor. In case of modern two-shaft designs, power is taken by the internal gearbox from the high pressure shaft [4] (p. 143). i.e. the outer and shorter of the two concentric shafts. But the drive may also take power from each engine shaft, so as to distribute the loads onto both shafts. Aircraft systems may in this case be driven from the low-pressure shaft [11] (p. 67). The high-pressure shaft rotates faster than the low-pressure shaft, which may also influence the choice of where to attach which accessory.

The *drive shaft* runs through the air ducts of the engine (see Figure 1). To limit the disruption to the airflow through the engine due to the drive shaft and the hollow fairing that encloses it, the shaft is designed as small as possible and hence runs at high speed [11].

The *accessory gearbox* (AGB) is usually arranged as a curved casing so that the various accessories are mounted close to the engine. Separate mounting pads are provided for each accessory (Figure 2). The drive within the casing is provided by a train of spur gears. Idler gears are commonly used between them, to increase the spacing between accessories. The accessories are arranged on both sides of the driveshaft entry, in reducing order of their speed.

Accessories for aircraft systems can be generators as Variable Speed Constant Frequency (VSCF) generators, Integrated Drive Generators (IDG) consisting of a Constant Speed Drive (CSD) and a generator, hydraulic variable displacement axial piston pumps, and high (e.g. for landing gear actuation) and/or low pressure compressors (e.g. for air conditioning; if not provided by the engine compressor) [11] (page 70 ff).

2 PRESENT TRENDS

Besides the introduction of new materials and new engines, the focus in civil aviation is on more efficient systems. These new systems and subsystems are generally “more electric” replacing some or all hydraulic and/or pneumatic systems by electric systems with the following improvements:

- higher engine efficiency (partly due to optimized compressor layout),
- better controllability and hence higher subsystem efficiency,
- absence of hot bleed air system with its maintenance demanding components,
- absence of hydraulic system with its tendency to hydraulic leakages.

But still three years after the maiden flight of the Boeing 787 – the first civil transport aircraft with electrical based, bleed less subsystem design – advantages and disadvantages of such a design [18] are not clear yet. One reason is that the effects of the different forms of off-takes (bleed air and shaft power off-takes) and their effect on engine fuel consumption are still not sufficiently discussed in the aviation community.

3 SECONDARY POWER THEORY

Secondary power on board an aircraft comprises of electrical power, hydraulic power, and pneumatic power. Electrical power and hydraulic power are generated from shaft power taken from the accessory gearbox of the aircraft’s engine. The required fuel consumption for secondary power generation first of all depends on the fuel consumption of the engine for aircraft propulsion. Chapter 3.1 presents a generic method to calculate the basic thrust specific fuel consumption (SFC) of a jet engine for propulsion. Chapter 3.2 presents the theory to calculate fuel consumption due to shaft power off-takes which is based on the basic SFC of the engine.

3.1 The Engine’s Specific Fuel Consumption

A typical value for the thrust specific fuel consumption (SFC) of today’s jet engines in cruise flight is $SFC = 16 \text{ mg}/(\text{Ns})$. Very advanced jet engines may have an $SFC = 14 \text{ mg}/(\text{Ns})$. Note that SFC is not a constant, but rather increases with aircraft speed or Mach number. Data is published for the SFC in normal cruise conditions [12] [13]. If published data is not available SFC may be calculated from an equation given by MATTINGLY converted in [12] to SI units:

$$SFC = (1.13 \cdot 10^{-5} + 1.25 \cdot 10^{-5} M) \sqrt{T/T_0} \text{ kg}/(\text{Ns}) \quad (1)$$

M is the flight Mach number. $T = T(h)$ is the temperature at altitude h . $T_0 = 288 \text{ K}$. A more details model for SFC is presented in [8] based on [20] (see also CD version of this paper).

3.2 Theory for Shaft Power Off-Takes

A fuel mass flow $\dot{m}_{F,P}$ provides the energy per unit of time to sustain shaft power off-takes P .

$$\dot{m}_{F,P} = SFC_P \cdot P \quad (2)$$

SFC_P is the power specific fuel consumption in kg/(Ws). Jet engines produce thrust T to propel an aircraft. It is custom to calculate the fuel flow of a jet engine \dot{m}_F based on the thrust delivered

$$\dot{m}_F = SFC \cdot T \quad (3)$$

SFC is the thrust specific fuel consumption in kg/(Ns) – sometimes also named SFC_T . Off-takes cause a change in SFC called ΔSFC . Therefore the fuel mass flow due to off-takes can also be expressed as

$$\dot{m}_{F,P} = \Delta SFC \cdot T \quad (4)$$

with (2)

$$\Delta SFC \cdot T = SFC_P \cdot P \quad (5)$$

$$\frac{\Delta SFC}{SFC} \cdot T = \frac{SFC_P}{SFC} \cdot P \quad (6)$$

Aim is to find a generic value describing shaft power off-takes varying only little with other parameters. It was observed that

- ΔSFC due to shaft power off-takes is roughly proportional to the SFC of the engine,
- ΔSFC is rather proportional to P/T than to P ; i.e. the same shaft power taken from a large engine does not consume as much fuel as taken from a small engine.

For these reasons it makes sense to define a *shaft power factor* k_p in this way:

$$\frac{\Delta SFC}{SFC} = k_p \cdot \frac{P}{T} \quad (7)$$

$$k_p = \frac{SFC_P}{SFC} \quad (8)$$

k_p has units of N/W and is determined from engine simulation tools (see Chapter 5) with

$$k_p = \frac{\Delta SFC / SFC}{P/T} \quad (9)$$

It is the aim of this paper to provide generic equations with which to calculate the shaft power factor k_p . Data and equations are given in Chapter 4 and 5. With known k_p the fuel consumption – the fuel mass flow – can be calculated from

$\dot{m}_{F,P} = k_p \cdot SFC \cdot P \quad (10)$
--

The *efficiency of shaft power generation* from a jet engine is calculated with help of the heating value of jet fuel (JET A-1) $H = 42.5 \cdot 10^6$ Nm/kg

$$\eta_P = \frac{P}{\dot{m}_{F,P} \cdot H} = \frac{1}{k_P \cdot SFC \cdot H} = \frac{1}{0.002 \cdot 16 \cdot 42.5} = 74 \% \quad (11)$$

The efficiency for shaft power off-takes with $k_P = 0.002$ N/W (Table 2), $SFC = 16$ mg/(Ns) (Chapter 3.1) is with 74 % a much higher value than for any other thermal process!

Shaft power P is known from data going along with the accessory device powered by the accessory gear box. This can be a generator, a hydraulic pump or whatever is connected. In the equations above $P = P_{in}$. This is the required input power into the accessory devices. Usually only the nominal output power P_{out} is know and the required input power has to be calculated from $P_{in} = P_{out} / \eta_{dev}$. With η_{dev} being the efficiency of the device as given in Table 1. [22] gives an efficiency of 0.7 for an IDG, [6] a value of 0.75.

Table 1 – Efficiencies of devices connected (directly or indirectly) to an accessory gearbox [16]

No	Device	Efficiency, η_{dev} [-]
1	generator and Variable Frequency (VF) generator	0.83
2	axial piston pump	0.87
3	electronic conversion unit	0.93
4	gear	0.95
5	Variable Speed Constant Frequency (VSCF) generator, consisting of 1 and 3	0.77
6	Integrated Drive Generator (IDG), consisting of 1, two units 2, and 4	0.72

4 PREVIOUS WORK

Little data is published on fuel consumption due to shaft power off-takes from the engine. Data from published and unpublished previous work is collected and presented in Table 2.

4.1 Data on Shaft Power Off-Takes

SAE with [19] (page 12) proposes with respect to shaft power off-takes $SFC_P = 0.5$ lb/(hp · h) = 0.304 kg/(kW·h) and $SFC = 1.5$ lb/(lb · h). With (8) this converts to $k_P = 0,00199$ N/W.

The turboprop engine EPI TP400-D6 for the A400M is said to have $SFC_P = 0.167$ kg/(kW·h) for shaft power extraction [2]. For propulsion this engine has a $SFC_P = 0.213$ kg/(kW·h) [13]. According to this data the engine is more efficient in producing shaft power than propulsive power. This fact confirms results from (11).

Table 2 – Summary of literature data for fuel consumption due to shaft power off-takes from the engine in cruise flight

Author / organization / engine	Source	Shaft power Specific Fuel Consumption SFC_P [kg/(kW·h)]	Engine Specific Fuel Consumption SFC [kg/(N·s)]	Shaft power factor k_P [N/W]
SAE	[19]	0.304	$4.25 \cdot 10^{-5}$	0.00199
CF6-80C2	[2] [12]	0.125	$1.64 \cdot 10^{-5}$	0.00212
EPI TP400-D6	[2] [13]	0.167	$1.07 \cdot 10^{-5}$	0.00434
SCHOLZ ^{1,4}	[15]			≈ 0.00188
YOUNG ²	[22]			
Trent 775 ⁴	[21]			0,00204
CF6-80C2-A2 ⁴	[21]			0,00177
CFM-56-5C-2 ⁴	[21]			0,00182
RB211-22 ⁴	[10]			0,00182
RB211-535E4 ⁵	[22]			0,00177
Trent 772 ⁵	[22]			0,00147
AHLEFELDER ^{3,5}	[1]			new evaluation:
3 shafts, mixed nozzle				0.00296
3 shafts, unmixed nozzle				0,00213
2 shafts, mixed nozzle				0,00226
2 shafts, unmixed nozzle				0,00308
DOLLMAYER ³	[6]			LP shaft: 0.00256 HP shaft: 0.00320
LAWSON	[9]			
BR 715-38				0.00175
Adour				0.00175
Average		0.199		0.00226
1	data from engine decks, average of different altitudes and Mach numbers			
2	data generated with TURBOMATCH (Chapter 5)			
3	data generated with GasTurb [7]			
4	data generated at maximum cruise thrust			
5	data generated at normal cruise thrust			

4.2 Engine Characteristics under Shaft Power Off-Takes

Shaft power extraction, no matter if taken from the HP shaft or the LP shaft will reduce the speed (rpm) of this shaft. This reduces the mass flow in that section of the engine and the thrust of the engines is reduced. Constant thrust regulation applied to the engine (achieved today by the Full Authority Digital Engine Control, FADEC [3]) will primarily result in an increase of fuel flow, increasing the Turbine Entry Temperature, TET. Higher pressure in the combustion chamber and higher turbine load together with a reduced shaft speed will enlarge the angle of attack at the compressor blades and therewith slightly lift the pressure rise achieved at each stage. In this way, shaft power off-takes also result in closer operation to the surge line. With higher pressure ratio and an increase in the speed of the turbine and the compressor and their mass flow a new equilibrium develops at the original thrust level.

5 ENGINE SIMULATION WITH SHAFT POWER OFF-TAKES

The effect of shaft power off-takes on the engine operating point cannot be generalized because of the complexity of a gas turbine. The location of the operating point within a wide operating range of an aircraft propulsion system to the design point of the engine and each of its components need to be considered. During simulation and model based engine performance investigations (at a certain operating point), the limiting factors like TET, spool velocities and stall/surge margins have to be observed. For this paper the simulation based investigations are done with TURBOMATCH.

5.1 Introduction to TURBOMATCH

The TURBOMATCH Scheme has been developed at Cranfield University to analyze design point and off-design point calculations for gas turbines. The different stages of the engine are simulated by means of pre-programmed routines referred to as “bricks” which are operated with the use of “code words”. The different stages are calculated individually and then the overall performance is calculated and presented in the form of thrust, SFC and other key engine parameters. The program has pre-loaded compressor maps and turbine maps that can be chosen according to the requirement.

5.2 Validation of the Baseline Engine in TURBOMATCH

Engine specifications are [5]:

- Engine Designation: RB211-524-D4
- Application: Boeing 747-200, Boeing 747-300
- By-Pass Ratio, BPR: 5
- Overall Pressure Ratio, OAPR: 29.5 (nominal sea level conditions)
- Maximum take-off thrust rating, T_{TO} : 51980 lbf
- Maximum continuous thrust rating, T : 47230 lbf
- Specific Fuel Consumption, SFC: 0.392 lb/lbf/h

The simulation model could be validated as shown in Table 3. The simulation model shows a deviation from published data in the design point of less than 5 % .

Table 3 – Design point simulation results

	Published value	Simulation result	Deviation	Simulation conditions
Maximum Take-off thrust rating, T_{TO} [N]	231207	241302	4.4%	The engine was simulated under the following conditions: 1. International standard atmospheric conditions at sea level 2. All optional bleed air closed 3. Aircraft accessory drives unloaded, hence no shaft power extraction 4. 100 % intake recovery
Thrust specific fuel consumption at max. take-off thrust ratio, T [kg/(Ns)]	$1.11 \cdot 10^{-5}$	$1.06 \cdot 10^{-5}$	4.7%	

5.3 Simulating Shaft Power Off-Takes with TURBOMATCH to yield k_P

As discussed previously the engine performance is penalized by extracting shaft power. For the case of the RB211-524-D4 engine analyzed with TURBOMATCH, the shaft power was extracted from the Low Pressure (LP) shaft. Many variables were used to create an engine performance database with shaft power off-takes to analyze the trends. The research focused on three altitudes h : 0 m, 5000 m, and 10000 m. The Mach number M was varied from 0 to 0.8 with an interval of 0.1 and the power off-take P was varied between 0 kW and 1600 kW in 10 steps. The net thrust was varied in the simulation by using the Turbine Entry Temperature (TET) as a handler from 1100 K to 1600 K with an interval of 100 K.

To study the penalties caused by the power off-takes, the SFC at each power off-take needed to be compared to the SFC at the same condition but without any power extraction. The problem is however, that as power is extracted thrust is reduced. A true and fair comparison can only be done with the same level of thrust. Also in real aircraft operation engine control (FADEC) would ensure thrust to be constant no matter what the power off-takes are. Engine control would allow burning more fuel to increase the TET in order to maintain the original thrust level.

Now instead of asking the simulation program to control the thrust (like a FADEC) for each power off-take under investigation rather a fine “no off-take grid” of thrust levels was created beforehand with TURBOMATCH giving the specific fuel consumption for no off-take conditions (Figure 3)¹. This grid was created for each of the 3 different altitudes and the 9 different Mach numbers studied in the research. For each of these 27 points 64 different TETs were used between 1000 K and 1600 K to generate the fine grid of 64 thrust levels.

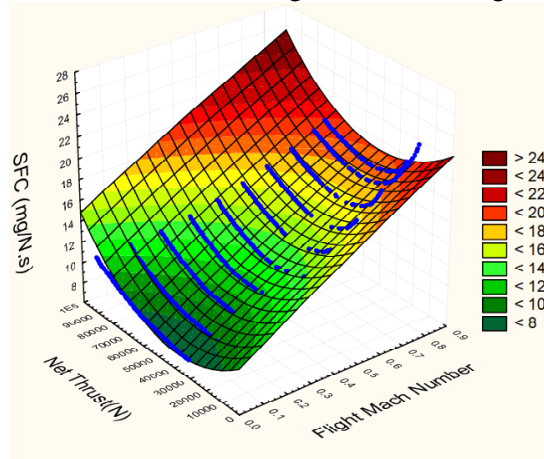

Figure 3 –Thrust specific fuel consumption SFC of the RB211-524-D4 engine plotted against net thrust and Mach number (data shown here is for 10000 m)

By using the appropriate point in the grid (as per altitude and Mach number), each of the 10 power off-take conditions with 6 different thrust levels (generated from 6 different TETs called TET_1) was matched to an equivalent thrust level in the “no off-take grid” (with thrust from that $TET_0 < TET_1$ yielding the best thrust fit). No matter how fine such a “no off-take grid” is created there will always be a small deviation in the thrust matching. This deviation is calculated from $[T(P, TET_1) - T(P=0, TET_0)] / T(P=0, TET_0)$. Except for very few cases the deviation in this thrust matching process was less than 7 %.

¹ No equation is given to represent Figure 6 for the SFC of the RB211-524-D4. Exact data was only necessary for the evaluation of the fuel consumption due to shaft power. If the reader needs an SFC value – as for use in (10) – he is referred to (1).

Now the relative change in specific fuel consumptions in each case was calculated with $\Delta SFC/SFC = [SFC(P, TET_i) - SFC(P=0, TET_0)] / SFC(P, =0, TET_0)$ comparing SFC with and without power extracted at approximately the same thrust. In Figure 4 $\Delta SFC/SFC$ was plotted against Mach number and values of relative power off-takes P/T (which is the power extracted, divided by the thrust of the engine at this condition). It can be observed that $\Delta SFC/SFC$ changes linearly with P/T . Since the slope of $\Delta SFC/SFC = f(P/T)$ is a constant the description can be simplified by just plotting this slope called k_p as defined in (7) and (9) (Figure 5). However, k_p is not a constant throughout the flight envelope. Figure 4 already shows that k_p decreases with Mach number. Figure 5 shows that this decrease is nonlinear. Figure 5 furthermore shows an increase of k_p with altitude.

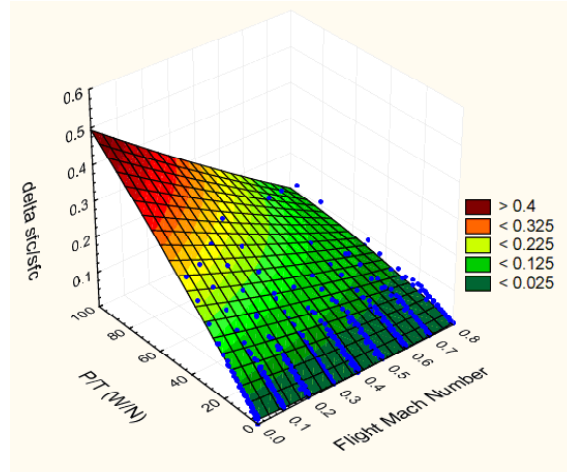

Figure 4 – Relative change in thrust specific fuel consumption of the RB211-524-D4 engine plotted against relative power off-takes (P/T) and flight Mach number (data is for a flight altitude of 5000 m)

Figure 6 shows a little more detail and reveals that k_p is about constant if P/T is sufficiently large. k_p taken as the average slope in Figure 6 is a good average value for k_p . For the evaluation with TURBOMATCH this also means, data is based on an average thrust level as obtained with a TET between 1100 K and 1600 K. At $h = 10000$ m and $M = 0.8$ the average thrust for which the evaluation is done is 18.7 % of take-off thrust. In other words $T/T_{TO} = 0.187$. So the evaluation is done at a typical cruise thrust level. k_p from Figure 5 can be represented by

$$k_p = 0.0057 + 4.60 \cdot 10^{-8} \frac{1}{m} h - 0.0106 M - 4.44 \cdot 10^{-13} \frac{1}{m^2} h^2 + 1.85 \cdot 10^{-7} \frac{1}{m} h \cdot M + 0.0049 M^2 \quad (12)$$

Since all turbo fan engines show similar behavior (see Figure 5 in the CD version of this paper) and the dependency on Mach number and altitude causes larger changes of k_p than a change of engines (operating at the same Mach number and altitude), (12) may be used as an approximation for all turbo fan engines as long as no other more specific data is available.

The values of k_p for $M = 0.8$ and $h = 10000$ m is 0.00225 N/W. This compares favorable with the average k_p from Table 2 which is 0.00226 N/W!

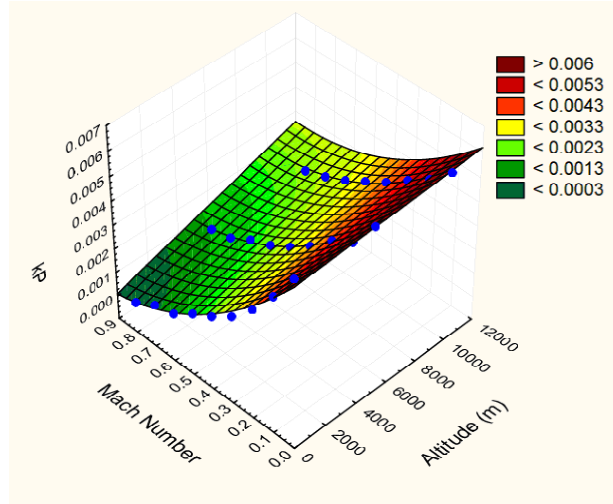

Figure 5 – Shaft power factor k_p of the RB211-524-D4 engine plotted against flight Mach number and altitude. Actual thrust T is used for this evaluation.

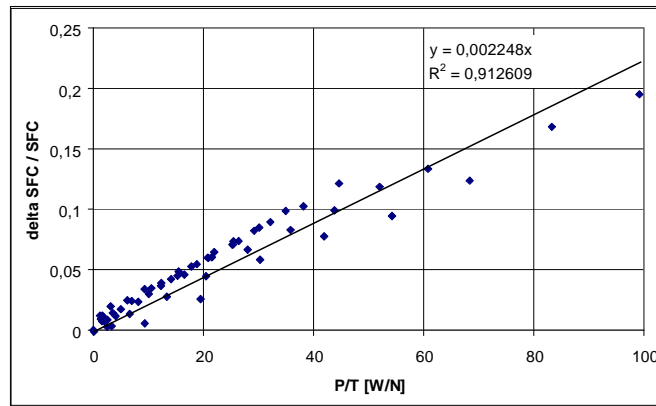

Figure 6 – Shaft power factor k_p of the RB211-524-D4 engine obtained as the slope of the function $\Delta SFC/SFC = f(P/T)$ with 0.002248 N/W . Actual thrust T is used for this evaluation.
Mach number: 0.8 and altitude: 10000 m

6 SUMMARY AND CONCLUSIONS

Fuel consumption due to shaft power off-takes can be calculated with

$$\dot{m}_{F,P} = k_p \cdot SFC \cdot P .$$

Equations for the shaft power factor k_p were derived from a data set generated with the engine simulation package TURBOMATCH of Cranfield University. k_p was found to be in the order of 0.00225 N/W for a typical cruise flight. This yields an amazingly high efficiency for the power generation by shaft power extraction from a turbo fan engine of more than 70 %.

More research is also necessary on bleed air off-takes. Only if bleed air off-takes are understood as well as shaft power off-takes it is possible to make a true comparison between the conventional aircraft and the more electric aircraft.

7 REFERENCES

- [1] AHLEFELDER, Sebastian: *Kraftstoffverbrauch durch Entnahme von Zapfluft und Wellenleistung von Strahltriebwerken*. Hamburg University of Applied Sciences, Department of Automotive and Aeronautical Engineering, Project, 2006
- [2] AIRBUS INDUSTRIE – Conversation with the aircraft manufacturer
- [3] AIRBUS INDUSTRIE: Flight Crew Operating Manual : A320. – Company Publication
- [4] BRÄUNLING, Willy J.G.: *Flugzeugtriebwerke*. Berlin : Springer, 2004
- [5] CIVIL AVIATION AUTHORITY: *Engine Type Certificate Data Sheet No.1043* (Issue 36). London : UK CAA, 12 October 1988. – URL: http://www.caa.co.uk/docs/1419/SRG_PRO_1043%20iss36.pdf (2013-02-18)
- [6] DOLLMAYER, Jürgen: *Methode zur Prognose des Einflusses von Flugzeugsystemen auf die Missionskraftstoffmasse*. Aachen : Shaker, 2007. – ISBN: 978-3-8322-6603-5
- [7] KURZKE, Joachim: GasTurb 8.0, 1998 – Software
- [8] HERRMANN, Steffen: *Untersuchung des Einflusses der Motorenzahl auf die Wirtschaftlichkeit eines Verkehrsflugzeuges unter Berücksichtigung eines optimalen Bypassverhältnisses*. Berlin, Technical University, Institute for Aerospace Sciences, Department of Aircraft and Lightweight Design, Thesis, 2010
- [9] LAWSON, Craig: *The Effects of Systems Power Off-Takes on Jet Engine Design and Performance*. Cranfield University, AVD Lecture Notes, 2011 (AVD 0439/1)
- [10] ROLLS-ROYCE: *Performance Specification and Installation Notes RB-211-22*. Derby, UK : Rolls-Royce, 1968
- [11] ROLLS-ROYCE: *The Jet Engine*. Derby, UK : Rolls-Royce, 1986. – ISBN 0-902121-04-9
- [12] ROUX, Élodie: Modèles Moteur : Réacteurs double flux civils et réacteurs militaires à faible taux de dilution avec PC. In : *Thèse : Pour une Approche Analytique de la Dynamique du Vol*, SupAéro, Toulouse, 2002. – URL: <http://www.elodieroux.com/ReportFiles/ModelesMoteurVersionPublique.pdf> (2013-02-13)
- [13] ROUX, Élodie: *Turboshaft, Turboprop & Propfan*. Blagnac : Éditions Élodie Roux, 2011. – ISBN 978-2-9529380-3-7
- [14] SAFRAN: *Hispano-Suiza teams up with Rolls-Royce on the Trent engine family*. URL: <http://www.hispano-suiza-sa.com/spip.php?rubrique20&lang=en> (2013-02-16)
- [15] SCHOLZ, Dieter: *Entwicklung eines CAE- Werkzeuges zum Entwurf von Flugsteuerungs-und Hydrauliksystemen*. Fortschritt-Berichte VDI, Reihe 20, No. 262, Düsseldorf : VDI, 1997. – Download from: URL: <http://publications.ProfScholz.de>
- [16] SCHOLZ, Dieter: *Direct Operating Costs of Systems with Bi-directional Hydraulic - Electric Power Conversion Units (HEPCU) & Direct Operating Cost Comparison : IDG versus VSCF Generator*. Neu Wulmstorf : Applied Science, 1998 (Report 4-98)
- [17] SCHOLZ, Dieter: DOCSys - A Method to Evaluate Aircraft Systems. In: Schmitt, D. (Ed.): *Bewertung von Flugzeugen* (Workshop: DGLR Fachausschuß S2 - Luftfahrtsysteme, München, 26./27. Oktober 1998). Bonn : Deutsche Gesellschaft für Luft- und Raumfahrt, 1998. – Download from: URL: <http://publications.ProfScholz.de>
- [18] SLINGERLAND, Ronald; ZANDSTRA, Sijmen: Bleed Air versus Electric Power Off-takes from a Turbofan Gas Turbine over the Flight Cycle (7th AIAA Aviation Technology, Integration and Operations Conference,ATIO, 18 – 20 September 2007, Belfast Northern Ireland), AIAA, 2007
- [19] SOCIETY OF AUTOMOTICE ENGINEERS: *Aerospace Information Report 1168/8 : Aircraft Fuel Weight Penalty due to Air Conditioning*. Warrendale, USA : SAE, 1989
- [20] TORENBEEK, Egbert: *Synthesis of Subsonic Airplane Design*. Dordrecht, NL : Kluwer, 1990
- [21] WILSON, R. A. L.: *The Introduction of Laminar Flow to the Design and Optimisation of Transport Aircraft*. Cranfield University, UK, Ph.D. Thesis 1997
- [22] YOUNG, T.M.: *Investigations into the Operational Effectiveness of Hybrid Laminar Flow Control Aircraft*. Cranfield University, UK, Ph.D. Thesis, 2002