

## Fundamental Limits on the Repetition Rate of Photomagnetic Recording

K. Szerenos,<sup>1,2</sup> A.V. Kimel,<sup>1</sup> A. Maziewski,<sup>2</sup> A. Kirilyuk,<sup>1,3</sup> and A. Stupakiewicz<sup>2,\*</sup>

<sup>1</sup>*Institute for Molecules and Materials, Radboud University, 6525 AJ Nijmegen, Netherlands*

<sup>2</sup>*Faculty of Physics, University of Białystok, 15-245 Białystok, Poland*

<sup>3</sup>*FELIX Laboratory, Radboud University, 6525 ED Nijmegen, Netherlands*

 (Received 20 June 2019; revised manuscript received 15 September 2019; published 25 October 2019)

The recently discovered phenomena of photomagnetic recording using femtosecond laser pulses in magnetic dielectrics opens up intriguing opportunities for ultrafast least-dissipative magnetic writing. Fundamental questions remain, however, about the processes, which limit the repetition rate of such writing. We report the magnetization dynamics and switching caused by a double-pulse excitation with various orientations of pump polarization. In particular, we study write and erase sequences, showing that mutual interference of the effects caused by two laser pulses can occur if the pulses are temporally separated by less than 60 ps. This imposes the fundamental limit for the repetition rate of writing (20 GHz), but this could be increased even further by strengthening the photoinduced magnetic anisotropy.

DOI: [10.1103/PhysRevApplied.12.044057](https://doi.org/10.1103/PhysRevApplied.12.044057)

### I. INTRODUCTION

The ever increasing demand for faster data processing fuels substantial efforts to search for ever faster ways to control matter. The idea to change structural, electronic, or magnetic properties of media using light has long intrigued researchers and motivated fundamental studies of photoinduced phase transition in magnetism [1], ferroelectricity [2], and superconductivity [3]. The field of photoinduced phase transitions became especially appealing after the development of lasers that can generate sub-100 fs pulses of light—the fastest stimuli in experimental condensed matter physics [4]. It was shown that coupling such a pulse to a specific mode of collective excitation in a medium represents the way forward to achieving the fastest ever switching of ferroelectric polarization [5], and even to induce superconductivity at room temperature [6]. The recently discovered phenomena of ultrafast photomagnetic recording in Co-doped yttrium iron garnet (YIG:Co) shows that femtosecond laser pulses facilitate not only one of the fastest write-read cycles in magnetic recording, but also the least dissipative [7]. A substantial breakthrough in the understanding of ultrafast light-induced magnetic recording was achieved with the development of femtosecond sources of x-ray radiation [8] and free-electron lasers [9]. Naturally, these experiments, being appealing for the future development of information technologies, raise questions about the fundamental limits of repetition rates at which light can switch matter between different stable bit states. Revealing the fundamental interactions

that limit this repetition rate, as well as aiming to achieve the highest frequency possible, should be seen as the next challenge in the field of ultrafast photoinduced phase transitions.

Although the possibility of controlling magnetism with light has been known for almost 50 years [10], before the development of femtosecond laser pulses, it was believed that photomagnetic recording was a slow process taking at least 100 ns [1]. Recent discoveries of all-optical magnetic switching of magnetization with the help of femtosecond laser pulses open up an alternative route for magnetic writing with light [11–13]. Using ultrafast laser-induced heating, one can write magnetic bits on metallic ferromagnetic (Gd,Fe)Co alloy within 30 ps [11,14]. It was further demonstrated that the switching can be repeated at frequencies up to 1 MHz [15]. While it has been suggested that the fundamental upper limit of this switching repetition rate should exceed tens of GHz, it is also obvious that the frequency is practically limited by the time required for cooling of the laser-excited area. In realistic magnetic metallic structures, this time is well in excess of 100 ps [16], resulting in the repetition rate being capped at <10 GHz. In contrast, femtosecond linearly polarized laser pulses can switch the magnetization in thin garnet films between stable states without relying on heat. Instead, the light changes the magnetic anisotropy of the medium via selective pumping of  $d-d$  electronic transitions in Co ions [17]. This recording is accompanied by a negligibly small temperature increase (on the order of 1 K), thus promising a dramatic increase in the repetition rate. Being inspired by this opportunity, our work aims to reveal the fundamental processes that define the

\*and@uwb.edu.pl

upper limit for the repetition rate of such photomagnetic writing.

In this work, we report about magnetization dynamics and switching caused by double-pulse excitation in YIG:Co. In particular, we use a sequence of pump pulses with different polarizations to write, erase, or rewrite magnetic bits. By varying the time delay between the consecutive pulses, we aim to reveal the minimum separation time between the pulses that enables reliable switching between stable bit states. The mutual inference of the effects caused by two laser pulses is observed if the separation time between the pulses drops below 60 ps. This finding demonstrates a tremendous increase of the repetition rate of the magnetic recording events up to 20 GHz. This is the highest frequency of magnetic recording demonstrated so far. We show that, in our case, the maximum repetition rate is defined by the period of the ferromagnetic resonance in the magnetic medium in combination with sufficiently large damping. This finding, therefore, suggests that the upper limit of the repetition rate can be increased even further by strengthening the photoinduced magnetic anisotropy. The paper is organized as follows. In Sec. II, we introduce the experimental details of the sample studied and the double-pulse excitation scheme of magnetization reversal. In Sec. III, we present the experimental results of coherent magnetization recording in different scenarios using two laser pump pulses. The conclusions are in Sec. IV.

## II. EXPERIMENTAL DETAILS

The garnet studied here is a single-crystalline 7.5- $\mu\text{m}$ -thick film grown by liquid phase epitaxy on GGG(001) substrate [7]. The YIG : Co domain structure in zero magnetic field consists of domains with both perpendicular and in-plane magnetization components [18]. This is due to an interplay of the dominant cubic magnetocrystalline and a small growth-induced uniaxial anisotropy yielding four easy magnetization axes near the body diagonals of the garnet cubic unit cell ( $\langle 111 \rangle$  axes). Additionally, using a film grown on a substrate with a miscut of  $4^\circ$  toward the [100] axis, it is possible to distinguish domains with different in-plane magnetization in a polarizing microscope [7,18].

Before starting measurements, the domain pattern in the sample is initialized by an external magnetic field applied in-plane along the [1–10] direction for several seconds. It results in a uniform domain pattern consisting of a large domain magnetized in a direction close to the [1–11] axis, filled with small labyrinth-like domains magnetized in a direction close to the [1-1-1] axis (similarly to Ref. [7]). These two types of domains are seen with the help of a magneto-optical microscope in Faraday geometry as white and black areas. Upon excitation with a single femtosecond laser pulse, an inversion of the magnetic contrast is

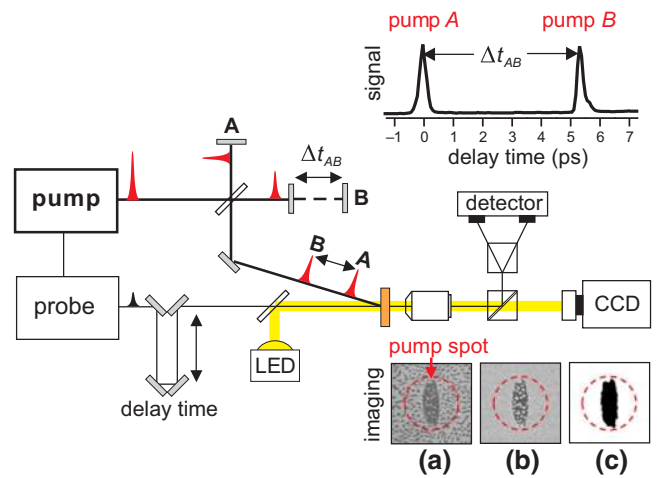

FIG. 1. The geometry of the double-pump experiment. Two pump laser pulses labeled “A” and “B” with the central wavelength  $\lambda = 1300$  nm and controlled polarizations are used to trigger magnetization precession or switching (a). The separation time  $\Delta t_{AB}$  between the two pump pulses is the experimental variable. The pump pulses are obtained via splitting the initial laser pulse in an interferometer. The separation time between the pumps can be varied by changing the length of one of the arms. The normalized switched area is calculated as the ratio of the recorded domain area [the large black domain in Fig. 1(c)] to the area of the laser spot  $\pi d^2/4$  (spot is shown by dashed red circle). (b) Magneto-optical difference image between images obtained after and before the double-pump excitation. The size of the images is  $200 \times 200 \mu\text{m}^2$ .

observed showing that the domains are switched, that is, the magnetization component perpendicular to the sample plane is reversed [see Fig. 1(a)]. Using light of different linear polarizations, it is possible to restore the initial contrast thus erasing the written magnetic domains. The thickness and the absorption coefficient of the studied garnet film allow us to claim that magnetic switching of the domains is uniform along sample depth [7].

Laser pulses with a duration of 50 fs and a repetition rate of 1 kHz are generated by Ti:Sapphire amplifier. We employ a combined setup allowing both imaging of microscopic magnetic domains and stroboscopic time-resolved Faraday rotation measurements (see Fig. 1). An optical parametric amplifier is used to tune the wavelength of the pump pulses to 1300 nm, matching an absorption peak of Co ions [19]. The probe wavelength is kept at 800 nm. The pump beam is focused to a spot with the full width at half maximum equal to  $d = 130 \mu\text{m}$ . An interferometer is used to generate a pair of pump pulses labeled as pumps A and B. Pump B arrives at the sample with a delay  $\Delta t_{AB}$  with respect to pump A and the delay can be controlled with picosecond resolution by changing the length of one of the interferometer arms (see Fig. 1). The polarization plane of the pump pulse is set at an angle  $\phi$  with respect to the [100] axis. The polarization plane of the probe beam is along the

[1–10] axis. The pulse intensities and their polarizations are adjustable separately. All measurements are performed without any applied external magnetic field and at room temperature.

### III. COHERENT CONTROL OF PHOTOMAGNETIC RECORDING

Previous time-resolved studies of laser-induced spin dynamics showed that the mechanism of photomagnetic recording in Co-doped iron garnet proceeds via a heavily damped precession of the magnetization in the field of photoinduced magnetic anisotropy. This finding suggests that the maximum repetition rate of the photomagnetic recording must be primarily defined by the period of the magnetic precession. However, the experimental evidence that no other effect is limiting the repetition rate has so far been missing. As a matter of fact, the highest frequency magnetic recording with light demonstrated so far has been limited to 1 MHz [15].

The switching mechanism relies on laser excitation of specific  $d-d$  transitions in cobalt ions [17,19–21]. Such an excitation lifts the degeneracy between otherwise stable magnetic states and launches heavily damped spin precession resulting in a deterministic switching to the state with lower energy. It was shown that the switching dynamics can be described by an exponential function with a characteristic time of 20 ps [7]. Moreover, these findings naturally raise questions about mutual interference of the effects caused by two laser pulses separated by time periods less than the lifetime of electrons in the excited state or the spin precession time. To answer this question and to reveal the characteristic time scale, which limits the repetition rate in photomagnetic recording, we perform double-pump experiments.

#### A. Writing cycle

To reveal interference between the effects of “write” pulses, we perform experiments when the single pump pulse intensity is about 25% less than the threshold intensity of the switching. This means that excitation with only one of the pulses is insufficient to write a domain. The results of the experiment are shown in Fig. 2. The image in the top panel of [Fig. 2(a)] shows the result of excitation with only  $A$  (or only  $B$ ) pulse. The difference image confirms that a single pulse excitation does not lead to writing a magnetic domain. Figure 2(b) shows the result of excitation with two overlapping pulses  $A$  and  $B$  ( $\Delta t_{AB} = 0$  ps). The image reveals that such an excitation records a magnetic domain. Further separation of the  $A$  and  $B$  pulses in time results in a decrease and eventual disappearance of the recorded domain at  $\Delta t_{AB} > 47$  ps. From the images, we estimate the switched area. The normalized switched area as a function of the delay between the pulses is shown in Fig. 2. It is seen that the effects of the pulses indeed

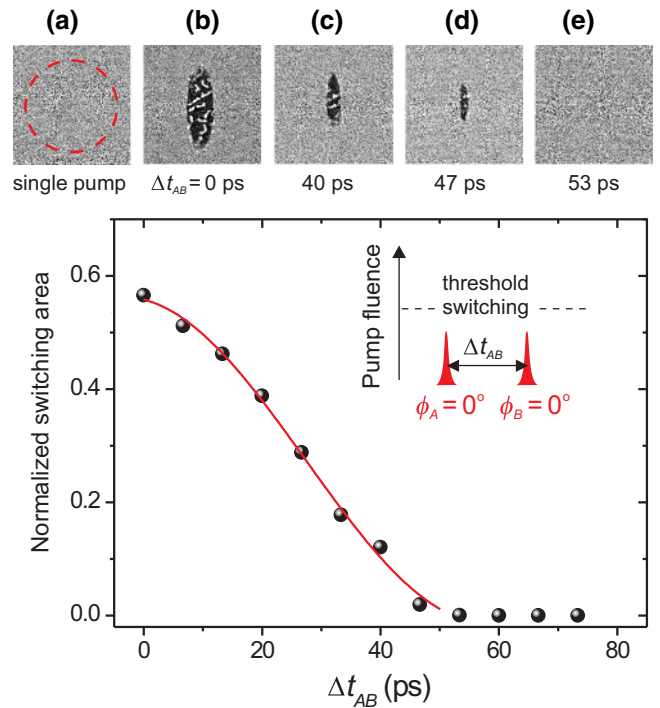

FIG. 2. Photomagnetic “write-write” sequence with two identical pulses linearly polarized along the [100] ( $\phi_A = \phi_B = 0^\circ$ ) crystallographic axis. The fluence is 25% less than the minimum required for single-pulse switching (see inset). The magneto-optical difference images (top panel) show the laser-induced changes of domain structure after excitation with (a) single  $A$  (or  $B$ ) pulse, (b) fully overlapping  $A$  and  $B$  pulses ( $\Delta t_{AB} = 0$  ps), (c)–(e) separated pulses when pulse  $B$  arrives after pulse  $A$ . The plot shows the switched area as a function of delay time between  $A$  and  $B$  pulses. The solid red line is a fit with  $\cos(2\pi \Delta t_{AB}/T)$  function where  $T/2 = 62 \pm 1$  ps. The fitting range is limited to the range with nonzero values of normalized switching area.

correlate up to 50 ps. For longer delays,  $\Delta t_{AB}$ , no switching is visible (see Fig. 2). In order to minimize the number of fit parameters, the experimental data are fitted with a periodic function without damping. The period of such function is then the direct measure of the correlation time between the pulses. The data in Fig. 2 suggests that the effective field of light-induced anisotropy decays within 50 ps after excitation. Note that this time is shorter than the quarter period of spin precession in YIG:Co (60 ps). However, if the lifetime of light-induced anisotropy is longer, it could become another limiting parameter for the repetition rate of recording.

To reveal the dynamics in the time interval between the two pump pulses, we further reduce the intensity of the pulses such that even two pulses together are not strong enough to switch the magnetization. This allows one to run the experiment in a stroboscopic pump-probe mode with a significant improvement of the signal-to-noise ratio. Figure 3(a) shows the dynamics of the time-resolved

magneto-optical Faraday effect triggered by two pump pulses separated in time by  $\Delta t_{AB}$ . One can notice that for short delays,  $\Delta t_{AB}$ , the excitations add up so that the precession amplitude is amplified. For longer delays,

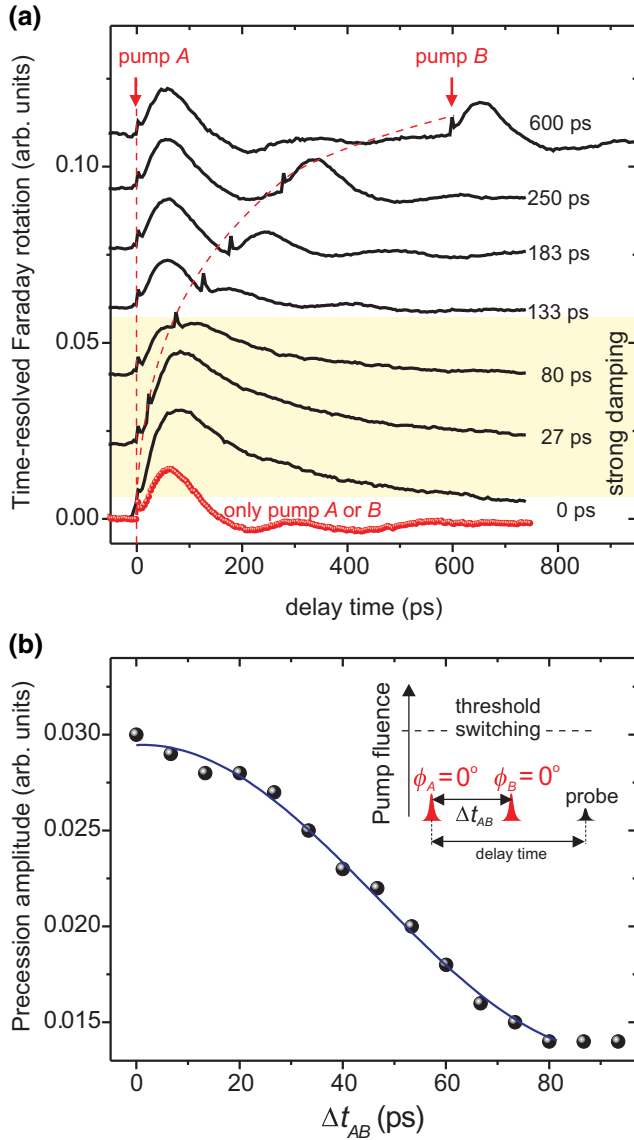

FIG. 3. Time-resolved magneto-optical Faraday rotation induced by two weak “write”-“write” pulses linearly polarized along [100] axis ( $\phi_A = \phi_B = 0^\circ$ ) with intensities of  $8 \text{ mJ/cm}^2$ . Even fully overlapping pump pulses cannot write a domain. (a) Shows time traces of the magneto-optical signal measured for different delays between the pump pulses  $\Delta t_{AB}$ . The filled red circles show magnetization dynamics for single pump *A* pulse. Pulse *B* alone triggers the same dynamics. The curves are shifted vertically without rescaling of the plots. (b) Shows the amplitude of magnetization precession as a function of  $\Delta t_{AB}$  deduced from data on panel (a). The solid blue line is a fit with  $\cos(2\pi \Delta t_{AB}/T)$  function where  $T/2 = 91 \pm 4 \text{ ps}$ . The fitting is limited to the range where the amplitude of the oscillations triggered by two pulses exceeds the amplitude of the oscillations triggered by pulse *A* alone.

excitation events become mutually independent and the magnetization dynamics triggered separately by *A* and *B* pulses are very much the same [see Fig. 3(a)]. It is also directly visible that the oscillations acquire stronger damping upon increasing the amplitude of the magnetic precession. In Fig. 3(a), the signals for  $\Delta t_{AB} = 0, 27$ , and  $80 \text{ ps}$  all show highly anharmonic magnetization precession. Thus, we confirm that the effective damping parameter also observed in stroboscopic experiments can depend on the amplitude of spin precession and thus on the pump fluence if the spin precession amplitude becomes large [22,23].

The signals in Fig. 3(a) show damping of the magnetization precession back to the initial state. However, note that the single pump intensity is  $8 \text{ mJ/cm}^2$ , which is only 25% of the threshold fluence required for switching. Thus, even if the two pumps overlap perfectly ( $\Delta t_{AB} = 0 \text{ ps}$ ), only 50% of the threshold fluence can be achieved. This means the magnetization cannot overcome the potential barrier and must relax back to the initial state. Figure 3(b) shows the amplitude of the laser-induced magnetization precession, defined as the maximum deviation of the magneto-optical signal from the initial value at a negative time delay. The amplitude decreases with an increase of the delay time  $\Delta t_{AB}$  and the dependence is very similar to that observed for the efficiency of switching in the imaging experiments (see Fig. 2).

As the measurements are performed without any applied magnetic field, the observed oscillations, if any, must be assigned to spin resonance in the field of magnetic anisotropy. Performing the measurements with a lower intensity than in the case of imaging, one induces a weaker magnetic anisotropy and thus the period of spin precession increases. Moreover, as observed above, the value of damping decreases with a decrease of the precession amplitude. In this case, the effective damping is close to the value obtained from ferromagnetic resonance ( $\alpha_{\text{FMR}} = 0.2$ ) [24]. In Fig. 3(a), for the high-amplitude precession regime when  $\Delta t_{AB} < 100 \text{ ps}$ , the damping value is approaching  $\alpha = 0.3$  [17]. As a result of these both effects, in the case of a stroboscopic experiment with less intense pump pulses, the interference between effects of the pulses is observed for longer separation times,  $\Delta t_{AB}$ , that is, up to  $80 \text{ ps}$  [Fig. 3(b)]. Figure 3 shows that the amplitude of spin precession triggered by two pump pulses increases when the pulses are separated by less than the quarter period of spin precession [7]. From data shown in Figs. 2 and 3, we conclude that in order to exclude mutual interference between two write pulses, one has to separate them for longer than a quarter of the period of ferromagnetic resonance.

## B. Write-erase sequence

Here, we examine a write-erase sequence triggered by two orthogonally polarized pump pulses as shown in



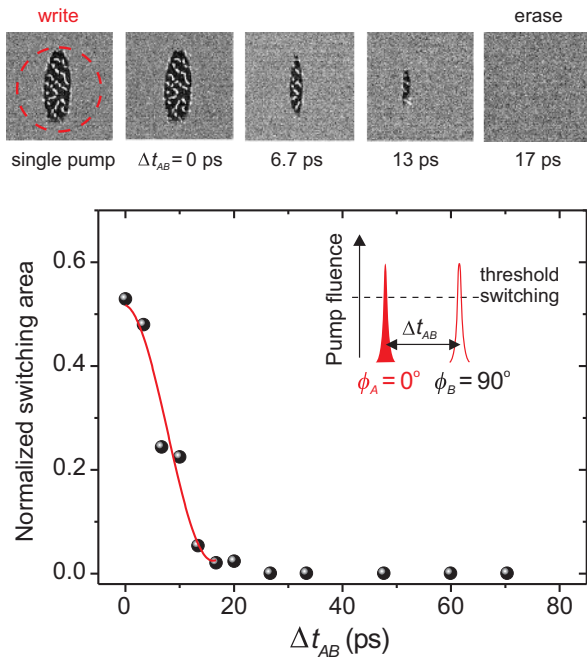

FIG. 4. The effect of a write-erase sequence. Top panel – magneto-optical difference images obtained after pumping with two pulses at different times of pump-pulses separation. The write-pulse  $A$  is linearly polarized along the  $[100]$  crystallographic axis ( $\phi = 0^\circ$ ). The erase pulse  $B$  is linearly polarized along the  $[010]$  axis ( $\phi_B = 90^\circ$ ). The graph shows the efficiency of switching as a function of separation between two pump pulses. The solid red line is a fit using  $\cos(2\pi \Delta t_{AB}/T)$  function where  $T/2 = 18 \pm 5$  ps. Fitting is limited to the range with nonzero values of normalized switching area.

Fig. 4. The first pump  $A$  launches a write process. The second  $B$  pulse steers the magnetization back to the initial state. The top panel in Fig. 4 shows magneto-optical difference images of the domains after  $A$ - $B$  pumps as a function of delay between pump pulses  $\Delta t_{AB}$ .

In the case of YIG:Co film with the nonzero miscut angle, the orthogonal polarizations along  $[100]$  and  $[010]$  directions have slightly different efficiencies of the magnetization switching. From Ref. [24], it is seen that pump with the polarization along the  $[110]$  axis that can be seen as a superposition of two pulses orthogonally polarized along the  $[100]$  and the  $[010]$  axes, triggers magnetization precession. The images show a perfect erasure already at the delay  $\Delta t_{AB} = 20$  ps. Results of stroboscopic pump-probe measurements using the two orthogonal pump pulses are shown in Fig. 5(a). In order to emphasize the effects of mutual interference and compare the result with Fig. 4, we plot the difference between the amplitudes of the oscillations triggered by both pulses and by pulse  $A$  alone. The dependence of the difference on  $\Delta t_{AB}$  is shown in Fig. 5(b) and reveals that the difference vanishes at a delay of about 30 ps. This time delay is close to the minimum separation time required as deduced from Fig. 4. In order to

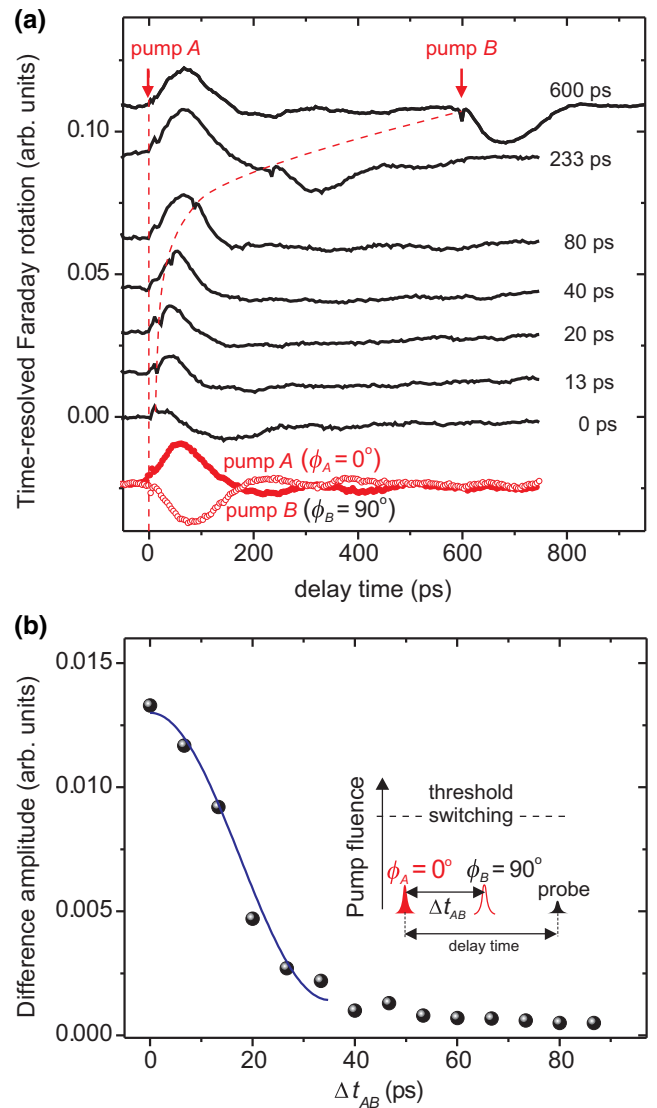

FIG. 5. Time-resolved magneto-optical Faraday rotation induced by two weak “write-erase” pulses. The write pulse is linearly polarized along the  $[100]$  ( $\phi_A = 0^\circ$ ) axis, while the erase pulse is polarized along the  $[010]$  ( $\phi_B = 90^\circ$ ). The pulse intensities are  $8 \text{ mJ/cm}^2$ , that is, at the level of 25% of the minimum fluence required for the switching. (a) Shows time traces of the magneto-optical signal measured at different delays between the pump pulses  $\Delta t_{AB}$ . The filled red circles show magnetization dynamics for single pump pulse  $A$ . Pulse  $B$  alone triggers the same dynamics. The curves are shifted vertically without rescaling of the plots. (b) Shows the difference between the amplitudes of the oscillations triggered by the double-pulse excitation and pulse  $A$  only. The solid blue line is a fit using  $\cos(2\pi \Delta t_{AB}/T)$  function where  $T/2 = 35 \pm 3$  ps.

compare the results of imaging and stroboscopic measurements shown in Figs. 4 and 5, one should note that the period of spin precession in the field of photoinduced magnetic anisotropy does depend on the intensity of the pump [24]. Higher pump fluences used in imaging experiments imply faster spin precession compared to the experiment

with stroboscopic measurements. Therefore, from Figs. 4 and 5, we also conclude that in order to exclude mutual interference between write and erase pulses, one has to separate them for longer than a quarter of the period of ferromagnetic resonance.

### C. Rewriting cycle

To further explore the dynamics of photomagnetic switching, we perform ultrafast write-erase-rewrite experiments using orthogonally polarized laser pulses. This experiment allows one to determine the minimum delay time between erasure and rewrite events for which a rewriting is still possible. The diagram in Fig. 6(a) shows the experimental steps. The initial pump “0” is linearly polarized along the [100] axis ( $\phi_0 = 0^\circ$ ). It prepares a switched domain. The pump “0” is prereleased from the interferometer with one of the arms blocked. Afterward,

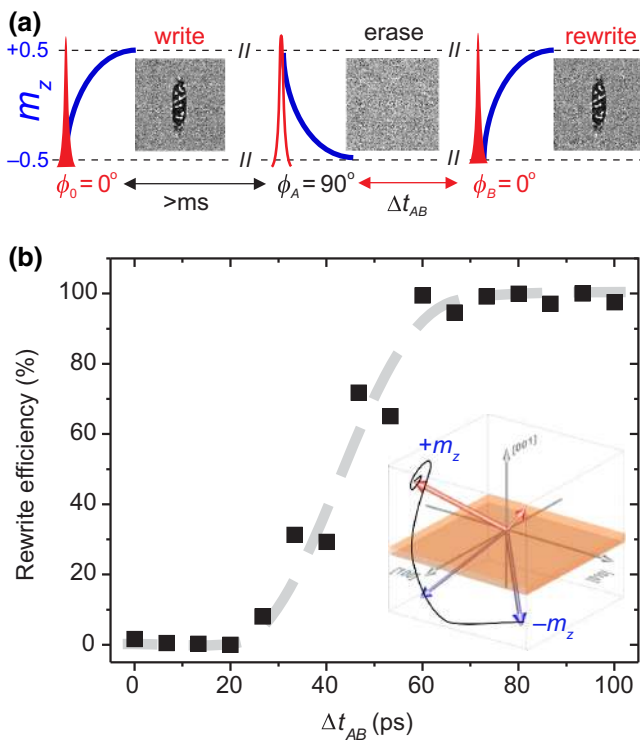

FIG. 6. The effect of write-erase-write sequence. (a) Magneto-optical difference images obtained after pumping with three pulses. After a domain is written by “0” pump, the medium is excited by a sequence of erase-write ( $A$ - $B$ ) pulses. The experiments are performed for a different time of separation between  $A$  and  $B$  pulses  $\Delta t_{AB}$ . The “0” pump write pulse is linearly polarized along the [100] crystallographic axis ( $\phi_0 = 0^\circ$ ). The erase-pulse  $A$  is linearly polarized along the [010] axis ( $\phi_B = 90^\circ$ ). The write pulse  $B$  is linearly polarized along the [100] axis. (b) Efficiency of switching as a function of separation between pump pulses’ separation. The dashed red line is a guide to the eye. The inset (b) shows the trajectory of magnetization switching calculated using the model from Ref. [17].

both arms are opened and two pump pulses  $A$  and  $B$  are prepared with the help of the interferometer. Pump  $A$  is now an erase pulse. It is linearly polarized along the [010] axis ( $\phi_B = 90^\circ$ ). Pump  $B$  is the writing pulse and it is linearly polarized along the [100] axis. Such a sequence mimics erasure and rewriting of a previously written domain (write-erase-rewrite cycle).

Figure 6(a) shows the idea of the experiment and how the domain pattern is expected to change after each pulse provided there is no interference between the effects of the pulses. By analyzing these images for different separation times  $\Delta t_{AB}$ , one can extract the dependence of the efficiency of rewriting. We define this efficiency as the ratio of the size of the domain by pump  $B$  to the size of the domain written by pump “0.” The efficiency as a function of  $\Delta t_{AB}$  is shown in Fig. 6(b). The figure reveals that rewriting is possible only for  $\Delta t_{AB} > 20$  ps. The efficiency increases up to 100% upon increasing  $\Delta t_{AB}$  from 20 to 60 ps. We would like to mention that the erase-rewrite process can be cycled multiple times. It is achieved simply by keeping the interferometer open and continuously feeding it with a 1-kHz sequence of pulses from the laser. From each laser pulse, that is, every ms, the interferometer produces a pair of  $A$  and  $B$  pump pulses. Even after 20 000 cycles, the domain is still rewritten with the exact same shape and size. Figure 6(b) implies that the minimum time between write, erase, rewrite events is equal to 60 ps. It corresponds to the maximum repetition rate of 20 GHz, which is the highest frequency demonstrated in magnetic recording until now.

## IV. CONCLUSIONS

Using linearly polarized single femtosecond laser pulses and transparent dielectric YIG : Co garnet, we demonstrate a proof-of-concept of high-frequency magnetic recording. It is shown that pulses separated by 60 ps can write and rewrite magnetic bits, avoiding the effects of mutual influence. These results underline the importance of the period of spin precession and demonstrate the feasibility of coherent control in the photomagnetic recording. Taking 60 ps as the minimum separation time between writing pulses, one concludes that the photomagnetic can operate at frequencies up to 20 GHz. The case considered here shows that the highest frequency of writing is practically defined by the frequency of spin resonance. Therefore, finding electronic or phononic excitations, as well as alternative media with even stronger effects of light on magnetic anisotropy, can pave the way to ultrafast, least-dissipative magnetic recording at unprecedentedly high frequencies far beyond the state of the art.

## ACKNOWLEDGMENTS

We acknowledge support from Grant No. TEAM/2017-4/40 of the Foundation for Polish Science cofinanced

by the EU within the ERD Fund and the Netherlands Organization for Scientific Research (NWO).

- 
- [1] V. F. Kovalenko and E. L. Nagaev, Photoinduced magnetism, *Sov. Phys. Usp.* **29**, 297 (1986).
- [2] V. M. Fridkin, *Photoferroelectrics*, Vol. 9 (Springer-Verlag, New York, 1979).
- [3] V. I. Kudinov, A. I. Kirilyuk, N. M. Kreines, R. Laiho, and E. Lähderanta, Photoinduced superconductivity in YBaCuO films, *Phys. Lett. A* **151**, 358 (1990).
- [4] C. Dornes, *et al.*, The ultrafast Einstein–de Haas effect, *Nature* **565**, 209 (2019).
- [5] R. Mankowsky, A. von Hoegen, M. Först, and A. Cavalleri, Ultrafast Reversal of the Ferroelectric Polarization, *Phys. Rev. Lett.* **118**, 197601 (2017).
- [6] D. Fausti, R. I. Tobey, N. Dean, S. Kaiser, A. Dienst, M. C. Hoffmann, S. Pyon, T. Takayama, H. Takagi, and A. Cavalleri, Light-induced superconductivity in a stripe-ordered cuprate, *Science* **331**, 189 (2011).
- [7] A. Stupakiewicz, K. Szerenos, D. Afanasiev, A. Kirilyuk, and A. V. Kimel, Ultrafast nonthermal photo-magnetic recording in a transparent medium, *Nature* **542**, 71 (2017).
- [8] I. Radu, K. Vahaplar, C. Stamm, T. Kachel, N. Pontius, H. A. Dürr, T. A. Ostler, J. Barker, R. F. L. Evans, R. W. Chantrell, A. Tsukamoto, A. Itoh, A. Kirilyuk, Th. Rasing, and A. V. Kimel, Transient ferromagnetic-like state mediating ultrafast reversal of antiferromagnetically coupled spins, *Nature* **472**, 7342 (2011).
- [9] C. E. Graves, *et al.*, Nanoscale spin reversal by non-local angular momentum transfer following ultrafast laser excitation in ferrimagnetic GdFeCo, *Nat. Mater.* **12**, 293 (2013).
- [10] R. W. Teale and D. W. Temple, Photomagnetic Anneal, A New Magneto-Optic Effect, in Si-Doped Yttrium Iron Garnet, *Phys. Rev. Lett.* **19**, 904 (1967).
- [11] A. Kirilyuk, A. V. Kimel, and Th. Rasing, Ultrafast optical manipulation of magnetic order, *Rev. Mod. Phys.* **82**, 2731 (2010).
- [12] C. D. Stanciu, F. Hansteen, A. V. Kimel, A. Kirilyuk, A. Tsukamoto, A. Itoh, and Th. Rasing, All-Optical Magnetic Recording with Circularly Polarized Light, *Phys. Rev. Lett.* **99**, 047601 (2007).
- [13] C.-H. Lambert, S. Mangin, B. S. D. Ch. S. Varapasad, Y. K. Takahashi, M. Hehn, M. Cinchetti, G. Malinowski, K. Hono, Y. Fainman, M. Aeschlimann, and E. E. Fullerton, All-optical control of ferromagnetic thin films and nanostructures, *Science* **345**, 1337 (2014).
- [14] T. A. Ostler, *et al.*, Ultrafast heating as a sufficient stimulus for magnetization reversal in a ferrimagnet, *Nat. Commun.* **3**, 666 (2012).
- [15] J.-Y. Chen, Li He, J.-P. Wang, and Mo Li, All-Optical Switching of Magnetic Tunnel Junctions with Single Subpicosecond Laser Pulses, *Phys. Rev. Appl.* **7**, 021001 (2017).
- [16] M. H. Kryder, E. C. Gage, T. W. McDaniel, W. A. Challenor, R. E. Rottmayer, G. Ju, Y.-T. Hsia, and M. Fatih Erden, Heat assisted magnetic recording, *Proc. IEEE* **96**, 1810 (2008).
- [17] A. Stupakiewicz, K. Szerenos, M. D. Davydova, K. A. Zvezdin, A. K. Zvezdin, A. Kirilyuk, and A. V. Kimel, Selection rules for all-optical magnetic recording in iron garnet, *Nat. Commun.* **10**, 612 (2019).
- [18] A. Maziewski, Unexpected magnetization processes in YIG + Co films, *J. Mag. Magn. Mater.* **88**, 325 (1990).
- [19] Z. Simsa, Optical and magneto-optical properties of Co-doped YIG films, *Czech. J. Phys.* **34**, 78 (1984).
- [20] D. L. Wood and J. P. Remeika, Optical Absorption of Tetrahedral  $\text{Co}^{3+}$  and  $\text{Co}^{2+}$  in Garnets, *J. Chem. Phys.* **46**, 3595 (1967).
- [21] B. Antonini, M. Marinelli, E. Milani, A. Paoletti, P. Paroli, J. Daval, and B. Ferrand, Site occupancy and valence state of optically active cobalt ions in yttrium iron garnet, *Phys. Rev. B* **39**, 13442 (1989).
- [22] C. S. Davies, K. H. Prabhakara, M. D. Davydova, K. A. Zvezdin, T. B. Shapaeva, S. Wang, A. K. Zvezdin, A. Kirilyuk, Th. Rasing, and A. V. Kimel, Anomalous Damped Heat-Assisted Route for Precessional Magnetization Reversal in an Iron Garnet, *Phys. Rev. Lett.* **122**, 027202 (2019).
- [23] Th. Gerrits, M. L. Schneider, A. B. Kos, and T. J. Silva, Large-angle magnetization dynamics measured by time-resolved ferromagnetic resonance, *Phys. Rev. B* **73**, 094454 (2006).
- [24] F. Atoneche, A. M. Kalashnikova, A. V. Kimel, A. Stupakiewicz, A. Maziewski, A. Kirilyuk, and Th. Rasing, Large ultrafast photoinduced magnetic anisotropy in a cobalt-substituted yttrium iron garnet, *Phys. Rev. B* **81**, 214440 (2010).