

DOCUMENT RESUME

ED 051 786

24

HE 002 324

AUTHOR Busching, Herbert W.
TITLE Fundamentals of Composite Materials for Undergraduate Engineering--A Filmed Presentation. Final Report.
INSTITUTION Clemson Univ., S.C.
SPONS AGENCY National Center for Educational Research and Development (DHEW/CE), Washington, D.C.
BUREAU NO BR-9-D-043
PUB DATE May 71
GRANT OEG-4-9-500043-0061-057
NOTE 27p.

EDRS PRICE MF-\$0.65 HC-\$3.29
DESCRIPTORS Curriculum Enrichment, *Engineering Education, *Film Production, Higher Education, *Instructional Films, *Student Participation, *Undergraduate Study
IDENTIFIERS *Composite Materials

ABSTRACT

Curricula in undergraduate engineering have not adequately reflected present usage and knowledge of composite materials (types of rock and organic matter in which structurally dissimilar materials are combined). Wide usage of composites is expected to increase the importance of this class of materials and the need for more substantive exposure to the uses and mechanics of composite materials at the undergraduate level. The purpose of the project described in this report was to produce a 22-minute instructional film that would enhance curricula in composite materials and to involve students in a mission-oriented project. Classes divided into 3-man teams assumed major responsibility for planning, researching, filming, and narrating parts of the film. Two semesters and 2 summer sessions were used for filming and initial editing. Evaluation of the project will continue as the film is shown, but most of the students and the instructor already consider the experience worthwhile and rewarding. The Appendix contains the substance of the film. (JS)

ED051786

DE/NCES

BE 9-D-043

PA 24

HE

Final Report

Project No. 9-D-043

Grant No. OEC-4-9-500043-0061-057

Herbert W. Busching
Department of Civil Engineering
Clemson University
Clemson, South Carolina 29631

FUNDAMENTALS OF COMPOSITE MATERIALS FOR UNDERGRADUATE ENGINEERING - A FILMED PRESENTATION

May 1972

U.S. DEPARTMENT OF HEALTH,
EDUCATION, & WELFARE
OFFICE OF EDUCATION
THIS DOCUMENT HAS BEEN REPRO-
DUCED EXACTLY AS RECEIVED FROM
THE PERSON OR ORGANIZATION ORIGIN-
ATING IT. POINTS OF VIEW OR OPIN-
IONS STATED DO NOT NECESSARILY
REPRESENT OFFICIAL OFFICE OF EDU-
CATION POSITION OR POLICY.

U.S. DEPARTMENT OF HEALTH, EDUCATION, AND WELFARE

Office of Education

National Center for Educational Research and Development
(National Research Program)



ED051786

AUTHOR'S ABSTRACT

Curricula in undergraduate engineering have not adequately reflected present usage and knowledge of composite materials. Disciplines in which knowledge of composites is important, however, include civil engineering, architecture, mechanical engineering, metallurgy and materials engineering. Wide usage of composites is expected to increase the importance of this class of materials and the need for more substantive exposure to the uses and mechanics of composite materials at the undergraduate level.

This research project was undertaken primarily to produce a short instructional film that would enhance curricula in composite materials. The instructional film was produced by undergraduate engineering students assisted by the principal investigator. Two semesters and two summer sessions were used for filming and initial editing of the film.

A secondary objective of the research was the involvement of students in a mission-oriented project. This was achieved by having the classes, after being divided into three-man teams, assume major responsibility for planning, researching, filming and narrating a two to three minute portion of the motion picture. Hence the project involved the students as learners as well as teachers. The project also provided the students with a novel opportunity to communicate more effectively by means of visual arts. Staff members from the Communications Center at Clemson University assisted the principal investigator in final editing of the film.

Final Report

Project No. 9-D-043
Grant No. OEG-4-9-500043-0061-057

FUNDAMENTALS OF COMPOSITE MATERIALS FOR UNDERGRADUATE ENGINEERING -
A FILMED PRESENTATION

Herbert W. Busching
Department of Civil Engineering
Clemson University
Clemson, S.C. 29631

May, 1971

The research reported herein was performed pursuant to a grant with the Office of Education, U. S. Department of Health, Education, and Welfare. Contractors undertaking such projects under Government sponsorship are encouraged to express freely their professional judgment in the conduct of the project. Points of view or opinions stated do not, therefore, necessarily represent official Office of Education position or policy.

U. S. DEPARTMENT OF
HEALTH, EDUCATION, AND WELFARE

Office of Education
National Center for Educational Research and Development

PREFACE

The principal investigator gratefully acknowledges the assistance of Dr. Michael Eitel, Dr. Jack Lemons, and Dr. Gilbert Robinson who reviewed and criticized the film. Special thanks go to Mr. Harry Durham of the Communications Center, Clemson University, for his capable support in producing the educational film which was a principal product of this project.

TABLE OF CONTENTS

	Page
Introduction	1
Methods	2
Results	5
Conclusions	6
Typical References	7
Appendix	8

INTRODUCTION

Composite materials are as old as nature. Some types of rock (e.g. sandstone) and organic material in which structurally dissimilar materials are combined are examples of natural composite materials. Synthetic composite materials have also been used for many years. For example, the Israelites used straw in their bricks to increase the tensile competence of the material and to permit the brick to dry faster.

At present, synthetic composite materials are gaining wide usage in engineering and architectural applications. Much of the literature and theory pertinent to composite materials has appeared within the last decade as a result of technological progress in the aircraft, synthetic fibers and plastics industries.

Because the technological importance of composite materials is relatively recent, however, little use or description of these materials is currently made in undergraduate engineering curricula. Studies of mechanical properties of composites have appeared predominantly in professional journals and technical proceedings which have limited circulation and therefore are not readily available to undergraduate students. The content of these publications has not been incorporated into undergraduate engineering curricula or typical materials texts.

Consequently, a principal objective of this project was the production of a short educational film on the fundamentals of composite materials. The film was to be of general interest but of special applicability in undergraduate engineering classes. The planning and production of the film was accomplished by students in civil engineering classes in concrete and bituminous materials.

Secondary objectives of the project included involving students in a novel and worthwhile learning experiment. Students were involved in the project as both learners and teachers. This novel approach to a portion of a traditional course was well received by the students. Junior and senior students in civil engineering and architecture were participants in the course which met each week for a one-hour lecture and a three-hour laboratory. One graduate teaching assistant was also assigned to the course and the film-making project.

Another objective of the course was to involve students in a significant project to improve communication skills. Employers of engineering graduates have expressed concern over lack of effective communication in graduate-employer relationships and in written reports. It was apparent that additional effort at the undergraduate level to improve communications skills was important. Engineers and technologists will be expected to be more vocal and more communicative outside their field of specialty as technological progress becomes more widespread. Evidence of this trend is apparent from public hearings in which engineers participate and in increased emphasis on developing empathy with client groups, especially in the public sector.

Utilization of fibers in composite materials is regionally important at Clemson University because the university is located in an area where synthetic fiber and fabric production are principal industrial activities. Major fiber industries located near Clemson University include Owens-Corning Fiberglas, Celanese Corporation, J. P. Stevens Company, American Enka Corporation, Phillips Fibers, and others.

METHODS

The major portion of the film was produced, in preliminary form, in two semesters of the 1969-70 academic year. The principal investigator spent some time prior to this evaluating ideas and materials that could be used by students.

When the semester began, the class was divided voluntarily into three-man laboratory groups. Students selected the groupings which were retained throughout the semester unless it was felt that regrouping would augment special skills that were needed to complete a segment of the film. Topics on normal course materials, concrete and bituminous materials, were deleted or shortened to provide additional time for producing the film.

The project began with the principal investigator and students discussing the goals of the film-making experiment. This was necessarily a brief exposure to the objectives that the film would fulfill in future curricula. Several orientation lectures and reading assignments were given to introduce students to composite materials. Representative reading assignments were either taken from some of the references listed at the end of this report or they were synthesized from several sources. Kelly's (10) "The Nature of Composite Materials" was one of the general reading assignments. Other references on composite materials were reserved and made available to class members in the civil engineering building. Students were also encouraged to read independently about composites in general and advanced references at the main library.

Lecture topics included mechanical principles such as stress concentrations around small holes in two-dimensional continua and mechanical properties of whiskers and fibers. Mechanical principles were summarized briefly in lecture material which was distributed to the class. Sample handouts are included in the appendix of this report. Other topics covered during familiarization lectures on composite materials included: fiber properties, including high specific properties; production of fibers, philosophy of fiber-reinforced composite materials; distribution of shearing and tensile stresses in a single fiber; functions of fiber and matrix; elastic-elastic and elastic-plastic modes of fiber-composite response; continuous and discontinuous fiber reinforcement; the law of mixtures.

Guest lectures were presented twice during each semester. An introduction to film making was presented to the class by the director of the Communications Center at Clemson University. A faculty member from the Division of Interdisciplinary Studies also lectured to the

class on composite materials used in dental fillings. Each laboratory group was responsible for producing a film treatment which is a sequence outline of the film where the main points to be covered in each sequence are described in a paragraph format.

Several films illustrating different visual aids and instructional techniques were shown to students. Students and instructor commented on the films and criticized techniques that were used in the films. The films included the following topics: construction procedures; filament-wound composites; concrete and bituminous materials; softening rock with a laser.

Topics for the film were discussed informally and then each member of the class was asked to submit a treatment of the film. Audio and visual portions of the film were submitted together with a list of suggested topics.

During the second semester of film making, students were shown the sequences that were made during the first semester. Suggestions were solicited from students in letter form. The letter was addressed to the student as though he were a consultant and was requested by his client to prepare part of an educational film on composite materials. The students replied individually by letter to the instructor outlining plans for their treatment of the film. The instructor replied by letter to each student to advise him of possible difficulties or advantages inherent in his treatment.

Topics that were eventually used in the film were suggested by class members. After the topics had been compiled, they were distributed to all students in the class and each three-man laboratory group was permitted to bid up to 1,000 points on one or more of the topics. In this way, students assigned the topics to themselves by interest level rather than by more arbitrary criteria. If a laboratory group's first choice was not bid high enough, that group had to accept its second choice or negotiate with other class members for the topic it wished to illustrate in the film.

Emphasis was placed on avoiding complex mathematical expressions in the film. The vocabulary used in the film was to be elementary and no technical terms were to be used without prior definition.

Supplies for some scenes were purchased in advance of film making by the instructor. Some groups purchased and made posters and models (Figure 1) for use in their presentations. The services of a departmental technician were made available to those students who needed them and minor expenses incurred by laboratory groups or individual students were paid from project funds on presentation of receipts. Figure 2 shows one of the devices designed by students.

Students were given unassigned laboratory time to experiment and refine their ideas and to do additional reading from the list of references. The instructor and graduate assistant conferred with individuals and laboratory groups regarding the treatment and feasibility of each of the topics.

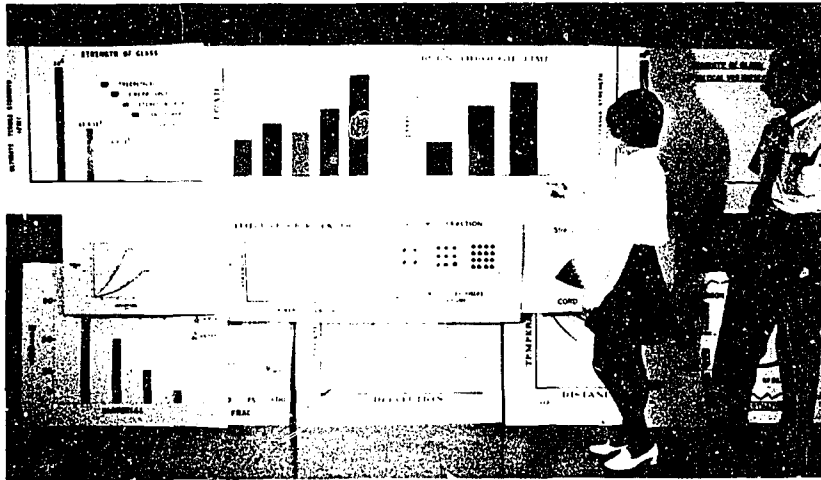

Figure 1. A number of student teams utilized charts and posters to enhance their presentations on principles of composite materials. This figure shows some of the posters made during the second semester of the project.

At midterm each laboratory group submitted a detailed narration and visual plan for the sequence for which that group was responsible. Groups were encouraged to utilize to the fullest extent possible the group and individual talents that could contribute most to an effective presentation.

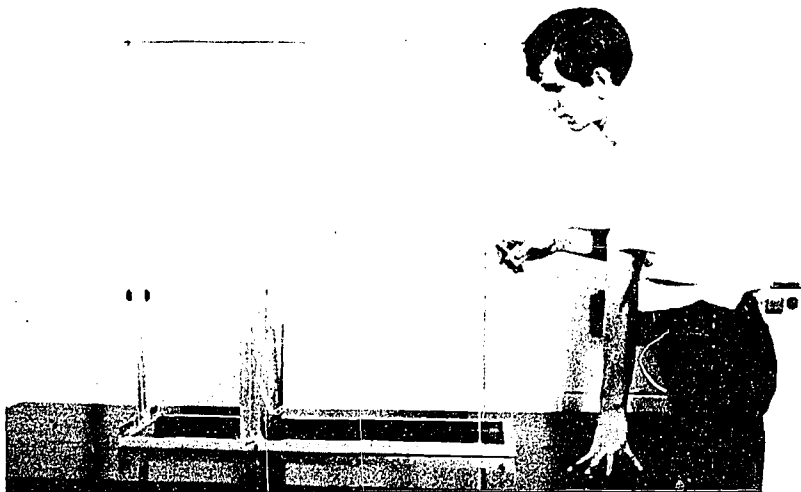

Figure 2. This device was designed by students and built by the departmental technician. The apparatus employs a pendulum that can be used to illustrate the impact resistance of planar composite materials.

One particularly useful device that assisted students and photographers was the preparation of a sequence of photographs taken by polaroid or conventional cameras. The photographs were assembled on posterboard (Figure 3) and assisted the cinematographer in previewing the scenes he was to photograph and the ideas he was to convey.

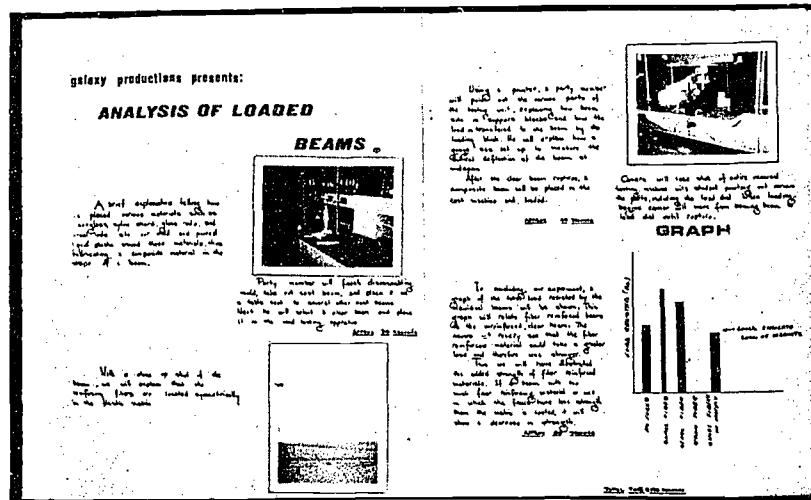

Figure 3. Posters with polaroid snapshots and suggested film topics were used to assist the photographer in previewing the scenes he was to photograph.

Final editing of the film was initiated by a group of students who rearranged several sequences and rewrote much of the script for narration. During one six-week summer session, a member of the class had several scenes rephotographed. Photos of graphs and charts were particularly difficult to photograph.

A variety of colors, textures and lighting conditions were encountered in filming and, consequently, it was inevitable that some sequences had to be rephotographed. Students accepted this additional work without inordinate dissatisfaction.

Additional editing of the film was continued during the remainder of the summer. All changes were made while using the workprint of the film.

RESULTS

A twenty-two minute educational film for undergraduate engineering students was the principal result of the project. The first edition of the film was shown at the Second Interamerican Conference on Materials Technology in late August in Mexico City. This meeting exposed the film two times to materials technologists from several countries. The reception of the film was favorable and some additional editorial changes were suggested.

The film was also reviewed critically by a group of persons from Clemson University's Department of Ceramic Engineering and from the Division of Interdisciplinary Studies. Changes suggested by these reviewers were incorporated into the final version of the film.

Evaluation of the project will continue as the film is shown in subsequent semesters to students in materials courses. In addition to submitting the teacher evaluation forms that are normally used at Clemson University, students were asked to evaluate their film-making experience. Evaluation of the class project on an individual, anonymous basis was made during the first semester. Approximately eighty percent of the students indicated that they thought the film-making experience was a good one. After completion of the project, there was evidence (Figure 4) that some student groups continued with film making. Most students thought that their classmates' participation in the laboratory group was adequate.

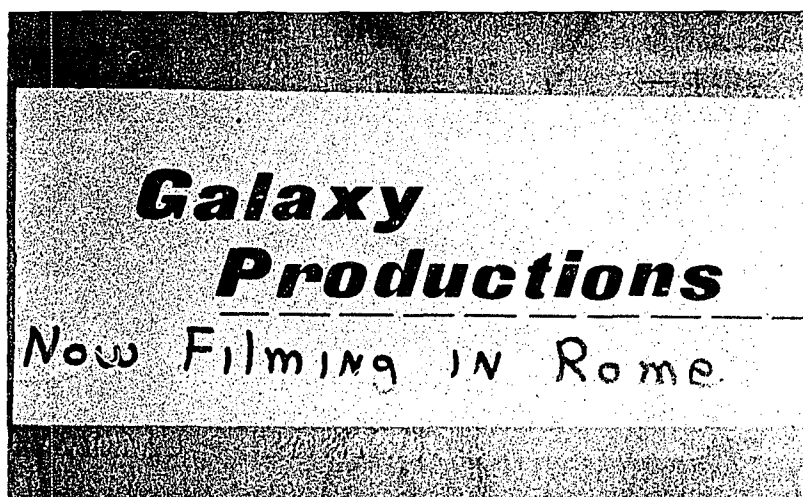

Figure 4. Graffiti such as that illustrated here indicated substantial identification of students with the project. Several student groups developed their own trademarks and letterheads during filming.

CONCLUSIONS

The project was considered to be worthwhile by students and instructor although the project could have been completed with less abbreviation of normal course content if it had been completed in a three-credit course. Copies of the film will be used in other materials-oriented courses in the future.

A copy of this film may be obtained on free loan from:

Dr. Herbert W. Busching, Head
Department of Civil Engineering
Clemson University
Clemson, South Carolina 29631

Although the project was considered worthwhile, it was probably too time consuming for inclusion in a two-credit course without serious abbreviation of normal course content. Use of similar mission-oriented projects in the undergraduate curriculum is advisable, however, for development of new concepts and involvement of students in significant learning and communications assignments.

TYPICAL REFERENCES

1. Sonneborn, Ralph H., "Fiberglas Reinforced Plastics," Reinhold Publishing Corporation, New York, 1954.
2. Hill, R., "Theory of Mechanical Properties of Fiber-Strengthened Materials: I. Elastic Behavior; II. Inelastic Behavior," J. Mech. Phys. Solids, Vol. 12, 1964.
3. Hashin, Z., "On Elastic Behavior of Fiber Reinforced Materials of Arbitrary Transverse Phase Geometry," J. Mech. Phys. Solids, Vol. 13, 1965.
4. Schapery, R. A., "Stress Analysis of Viscoelastic Composite Materials," Journal of Composite Materials, Vol. 1, No. 3, 1967.
5. Kelly, A., Davies, G. J., "The Principles of the Fiber Reinforcement of Metals," Metallurgical Reviews, Vol. 10, No. 37, 1965.
6. Carrarra, Anthony S. and McGarry, Frederick J., "The Effect of Fiber End Geometry on the Stresses in a Resin-Glass Composite," MIT Research Report R67-43, September, 1967.
7. Fujiwara, Motozo, "Resin-fiber Load Transfer in Fiber-reinforced Plastics," MIT Research Report R67-8, February, 1967.
8. Haslett, William H. and McGarry, Frederick J., "Shrinkage Stresses in Glass Filament-resin Systems," Modern Plastics, Dec., 1962.
9. Jones, Russell C., "Structural Metal Composite," Civil Engineering, February, 1967.
10. Kelly, A., "The Nature of Composite Materials," W. H. Freeman and Company, San Francisco, 1967, pp. 96-110.
11. Holliday, Leslie, "Composite Materials," Elsevier Publishing Company, New York, 1966.
12. Kelly, A., "Strong Solids," Clarendon Press, Oxford, 1966.
13. Polakowski, N. H. and Ripling, E. J., "Strength and Structure of Engineering Materials," Prentice-Hall, Inc., Englewood Cliffs, New Jersey, 1966.
14. Cox, H. L, British Journal of Applied Physics, Vol. 3, 1952, p. 72.

APPENDIX

Exhibit A-1. Notes on fiber-reinforced composites distributed to all students participating in the project.

Fiber-Reinforced Composites

Used because

- a. High strength form of most materials is fibers or whiskers.
- b. Can use materials with high specific properties.
- c. Can improve elevated temperature resistance, stiffness and ultimate tensile strength
- d. Crack propagation resistance greatly enhanced by presence of fibrous reinforcement.
- e. Controlled anisotropy and complex shapes possible with composite materials, at least in theory.

Disadvantages

- a. Problems of bonding and adhesion.
- b. Stress concentrations and residual stresses.
- c. Fatigue resistance problems--both mechanical and thermal.
- d. Control over distribution and orientation of fibers.
- e. Connections, discontinuities and changes in section.
- f. Cost and quality control.

Composite Properties and Behavior

Dependent upon properties and behavior of components.

Fibers

Ductile or brittle?
Continuous or discontinuous?
Oriented or randomly distributed?
Volume fraction present?

Matrix

Ductile or brittle?
Work hardens or ideally plastic?

Exhibit A-2. Equations for the stress field around a small circular hole in a large elastic plate.

Circular Hole in a Loaded Plate

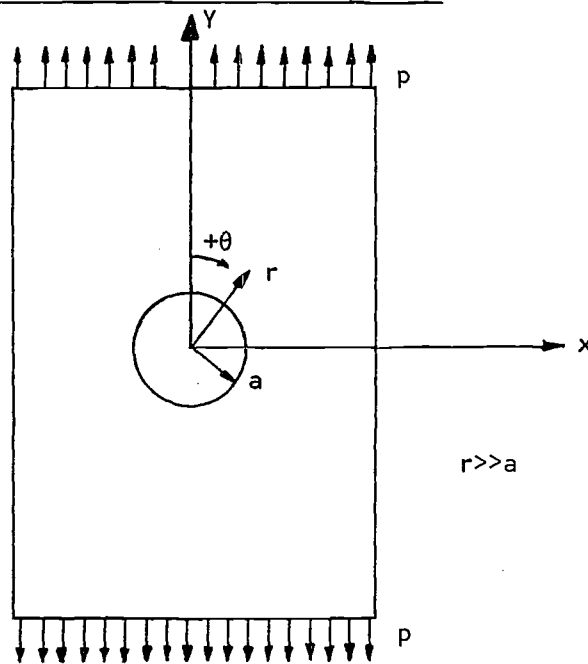

$$\sigma_r = \frac{p}{2} \left(1 - \frac{a^2}{r^2}\right) \left[1 + \left(1 - 3\frac{a^2}{r^2}\right) \cos 2\theta\right]$$

$$\sigma_\theta = \frac{p}{2} \left[1 + \frac{a^2}{r^2} - \left(1 + 3\frac{a^4}{r^4}\right) \cos 2\theta\right]$$

$$\tau_{r\theta} = \frac{p}{2} \left(1 - \frac{a^2}{r^2}\right) \left(1 + 3\frac{a^2}{r^2}\right) \sin 2\theta$$

$$\text{@ } r = a$$

$$\sigma_\theta = p(1 - 2 \cos 2\theta)$$

Exhibit A-3. Introductory notes on mechanical properties of composite materials.

Mechanical Properties of Composite Materials

Any combination of two or more materials can be considered to be a composite; however, the combination must have its own distinctive properties. Generally, composite materials have high modulus-to-weight and high strength-to-weight ratios. In addition, the composite may have other distinctive properties such as a high melting point or high resistance to fatigue. Resins and polymers, in particular, have high strength-to-weight ratios and can be combined effectively with other materials to produce structural composites.

The presence of holes and cracks within materials has been shown to have a detrimental effect on the strength of all materials. This is particularly true for the tensile strength of materials which is more noticeably flaw-dominant than is compressive strength. The flaw-dominant tensile strength phenomena is sometimes referred to as the weakest-link hypothesis.

The production of very thin filaments which began with commercial production of fiberglass and synthetic fibers approximately forty years ago has done much to increase the ultimate tensile strength of many materials. Decreasing the diameter of a fiber, decreases the probability of large flaws being present and thereby increases the tensile strength of the material. Very thin filaments of noncrystalline or polymeric materials have been manufactured in which the ultimate tensile strength approaches the theoretical ultimate tensile strength. Single crystals of materials, or whiskers, also have high ultimate tensile strengths.

In general, the high strength materials in filamentary or crystalline form are included as reinforcement in other materials. The material in which the reinforcement is incorporated is called the matrix. Kelly (1) notes that the matrix carries out several functions:

"(1) it protects the surface of the individual fibers so that the strength is not lost by abrasion of the surface either by extraneous matter or by other fibers. (2) It separates the individual fibers and prevents a brittle crack passing completely across a section of the compact entirely in the strong and usually brittle phase. (3) It provides a means by which load is applied to the strong phase."

The relationship between fiber diameter and ultimate tensile strength is shown in Fig. E-1. Taking advantage of the high tensile strength of thin fibers requires that matrix and reinforcement be bonded together firmly so that the high tensile stresses in the fibers can be dissipated along the periphery of the fiber as shearing stresses in the matrix.

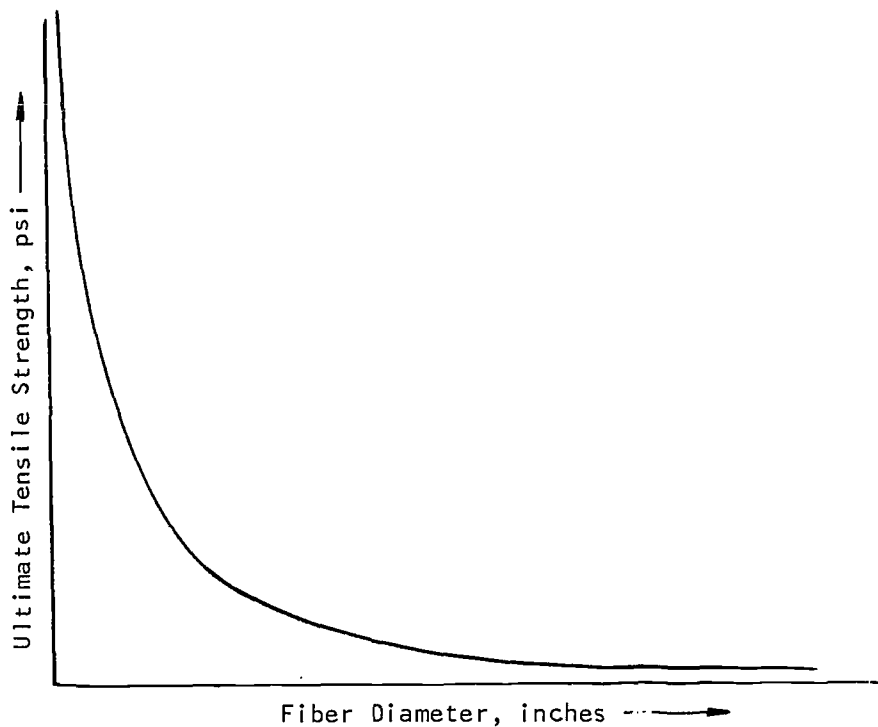

Figure E-1. Relationship Between Ultimate Tensile Strength and Fiber Diameter.

Continuous as well as discontinuous fibers can be incorporated into matrices to form strong composites. Although the state of stress and strain within fibers and matrices is complex, useful approximations of the mechanical response of fiber-matrix composites can be made. We shall consider, first of all, a single fiber of length l completely embedded in a continuous matrix. Fig. E-2 shows the fiber within a homogeneous matrix. The entire composite element is subjected to a strain ϵ_i in the direction of the fiber and P is the load in the fiber at a distance x from the end. Now we assume that

$$\frac{dP}{dx} = H(u - v) \quad (1)$$

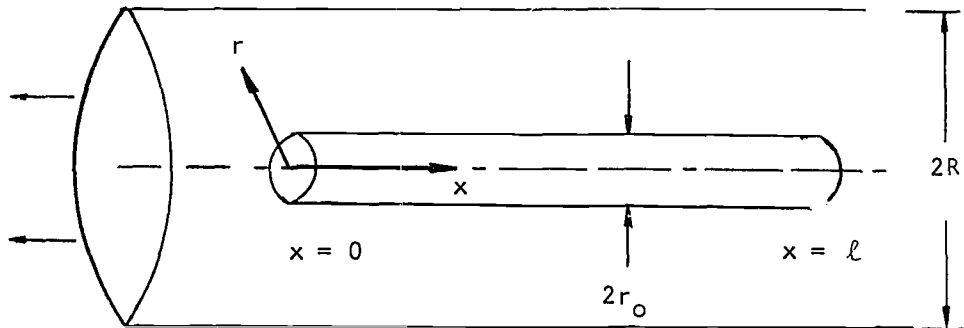

Figure E-2. A Long, Thin, Straight Fiber Completely Embedded in a Continuous, Homogeneous Matrix. (Elastic-Elastic System)

where u is the longitudinal displacement in the fiber and v is the corresponding displacement the matrix would undergo at the same point if the fiber were not present. H may be a function of time, but in this case we consider it to be a constant, the value of which depends on the geometrical arrangement of the fibers and matrix and on their respective elastic moduli.

If E_f is Young's modulus and A_f is the area of cross section of the fiber, then

$$P = E_f A_f \frac{du}{dx} \quad (2)$$

Since $\frac{dv}{dx} = \epsilon_{ii} = \text{constant}$, differentiation of (1) and its substitution in (2) yields

$$\frac{d^2P}{dx^2} = H \left[\frac{P}{E_f A_f} - \epsilon_{ii} \right] \quad (3)$$

The solution of this equation is

$$P = E_f A_f \epsilon_{ii} + R \sinh \beta x + \beta x \quad (4)$$

where R and S are constants. The end conditions are $P = 0$, at $x = 0$ and at $x = l$. We then obtain for the distribution of tensile stress

$$\text{in the fiber, } \sigma = E_f \epsilon_{ii} \left[1 - \frac{\cosh \beta(l/2 - x)}{\cosh \frac{\beta l}{2}} \right] \quad (5)$$

where $\beta = \frac{H}{E_f A_f}$.

The variation of tensile stress, σ , along the fiber is shown in Fig. E-3. No load is transferred across the end faces of a fiber and hence the tensile stress builds up from the ends to some maximum value. Equation (5) shows that only infinitely long fibers can be strained to the strain of the composite.

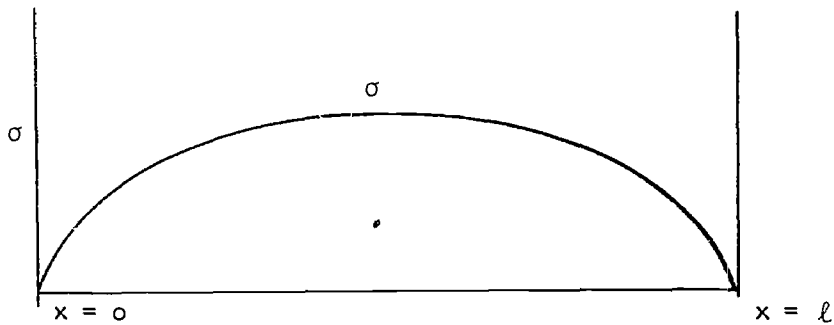

Figure E-3. The variation of Tensile Stress, σ , along a Fiber of Length, l , According to Equation (5).

The average tensile stress in the fiber is

$$\sigma = E_f \epsilon_{ii} \left[1 - \frac{\tan h \beta l / 2}{\beta l / 2} \right] \quad (6)$$

Based on this simple model of a composite element, Young's modulus of the composite will be

$$E_c = E_f V_f \left[1 - \frac{\tan h \beta l / 2}{\beta l / 2} \right] + E_m (1 - V_f) \quad (7)$$

where V_f is the fractional area of the cross-section occupied by the fibers and E_m is Young's modulus of the matrix. V_f is often referred to as the volume fraction of the fiber phase.

Calculations of stress transfer in the composites with parallel fibers must also include consideration of shear stresses. Again, we consider reinforcing fibers of length l and constant circular cross-section of radius r_0 . The mean center-to-center separation of the fibers is $2R$ and, in general, one would expect the shear stress $\tau(r)$ to be a function of the fiber radius. At the surface of the fiber $r = r_0$, and

$$\begin{aligned} \frac{dP}{dx} &= -2\pi r_0 \tau(r_0) \\ &= H(u-v) \end{aligned} \quad (8)$$

Hence,

$$H = \frac{2\pi r_o \tau(r_o, 0)}{(u-v)} \quad (9)$$

If w is the actual displacement in the matrix close to the fiber, then at the fiber-matrix interface, assuming there is no slippage between fiber and matrix, $w = u$. At a distance R from the central fiber we have $w = v$. Equilibrium of the matrix between r_o and R requires

$$2\pi r \tau(r) = \text{constant} = 2\pi r_o \tau(r_o) \quad (10)$$

and hence the shear strain in the matrix is given by

$$\frac{dw}{dr} = \frac{\tau(r)}{G_m} = \frac{\tau(r_o) r_o}{G_m r} \quad (11)$$

where G_m is the shear modulus of the matrix.

Integrating from r_o to R yields

$$\Delta w = \frac{\tau(r_o) r_o}{G_m} \ln \left(\frac{R}{r_o} \right) \quad (12)$$

Since $\Delta w = u - v$, equation (9) yields

$$H = \frac{2\pi G_m}{\ln \left(\frac{R}{r_o} \right)} \quad (13)$$

and therefore a new definition of β results.

$$\beta = \sqrt{\frac{G_m}{E_f}} \left(\frac{2\pi}{A_f \ln \left(\frac{R}{r_o} \right)} \right) \quad (14)$$

As G_m/E_f becomes larger, stress in the fiber increases more rapidly with distance from the fiber ends. All expressions have been derived with the following assumptions being implicit:

- (a) no tensile stress is assumed transmitted across a fiber end.
- (b) stress-concentrating effects of fiber ends are neglected.
- (c) effects on the stress in one fiber of a nearby fiber end are neglected.
- (d) materials are homogeneous and continuous.

Equations (5) and (8) can be used to find the shear stress, τ , in the matrix at the fiber-matrix interface. For circular fibers

$$P = \pi r_o^2 \sigma \quad (15)$$

and hence

$$\tau = E_f \epsilon_{ii} \sqrt{\frac{G_m}{E_f 2 kb (R/r_o)}} \cdot \frac{\sinh \beta (\ell/2 - x)}{\cosh \beta \ell/2} \quad (16)$$

The variation of shear stress with fiber length is shown in Fig. E-4. The shear stress is a maximum at the fiber ends and a minimum at the center of the fiber.

The ratio of the maximum value of τ to the maximum value of the tensile stress in the fiber is,

$$\frac{\tau_m}{\sigma_m} = \sqrt{\frac{G_m}{2E_f \ln R/r_o}} \cdot \frac{\sinh \beta \ell/2}{\cosh \beta \ell/2 - 1} \quad (17)$$

For a very long fiber

$$\frac{\tau_m}{\sigma_m} = \sqrt{\frac{G_m}{2E_f \ln R/r_o}} \quad (18)$$

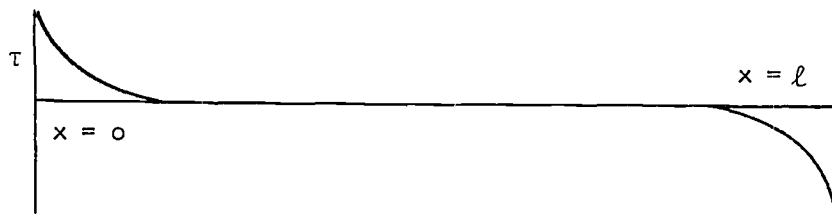

Figure E-4. The Variation of Shear Stress, τ , Along a Fiber of Length ℓ , According to Equation (16).

Exhibit A-4. List of topics suggested for inclusion in the film on composite materials (Spring, 1970, class).

TOPICS SUGGESTED FOR FILM

<u>Topic</u>	<u>Name</u>
1. Glass and glass with wire in it	Griffith
2. Natural composites	Ross
3. Breakaway traffic sign post	Dunn
4. Demonstration of high specific strength	Tillotson
5. Ultimate tensile strength	Ritch
6. Flaws decrease UTS/bending strength of glass	Lee
7. -	Rowell
8. Cross lamination related to strength	McCullough
9. -	Shannon
10. Thermal conductivity	Finley
11. Lucite, photoelastic demonstration	Koss
12. Photoelastic fracture/audio editing	Wilson
13. Introduction/tire structure	McCoy
14. Golf ball/waterproofing	Page
15. Rapid sequence/waterproofing	Davis
16. Bamboo and concrete/glass with wires	Groover
17. Properties of composite materials	Longshore
18. Weakest link hypothesis/lamination	Eck
19. Natural composites (celery, etc.)	Kwist
20. Strength of glued joints	Werts
21. Chopped strand and continuous strand materials	Smith
22. Strength of glass	Harvey
23. Photoelastic experiment/resonance	Lynch
24. Photoelastic models	Froneberger
25. Glass strengthening through quenching	McArdle
26. Composites as beam flanges	Bopp
27. Future uses of composites	Bridwell
28. Cross-section of a tire	Williams
29. Glass behavior	Cribb
30. Effect of different sizes and types of reinforcing	Adamo
31. Thermal characteristics of composites	Arrington
32. " " " "	Wicker
33. Strength-volume fraction relationship	Whittington
34. Breakaway sign posts	Jones
35. Strength relationships, tension, heat transfer	Fisher
36. Plane landing/jello	Roeser
37. Laminated beam/breakaway sign standards	Holder
38. Lamination/narration	Laubach
39. Natural composites	Wilfinger
40. -	Sweeney

CLEMSON UNIVERSITY
CLEMSON, SOUTH CAROLINA 29631

COLLEGE OF ENGINEERING
DEPARTMENT OF CIVIL ENGINEERING

February 6, 1970

TELEPHONE 656-3001
AREA CODE 803

CE 320 Students, Inc.
Department of Civil Engineering
Clemson University
Clemson, South Carolina 29631

Dear Student:

Our department is involved in making an educational film on composite materials and I am particularly glad that you have been retained as a consultant on this project. The purpose of the thirty-minute film is to demonstrate the nature and mechanics of composite materials to undergraduate students in engineering and science. Naturally, I am interested in your treatment of this topic.

I am therefore requesting that you prepare in paragraph format your original treatment of the film. Please indicate in detail the topics that you feel should be included in the film. Order the topics in the sequence that would best develop the subject matter and tell me which topic you would like your group to work on. You will have an opportunity to work on one of the scenes in detail at a later date.

Please return your reply to me at the address shown above by next Friday, February 13. Your assistance will be greatly appreciated.

Very truly yours,

Herbert W. Busching

Herbert W. Busching
Associate Professor and Head

HWB/fw

Exhibit A-5. Letter assignment sent to each class member, Spring, 1970.

ce 320 students, inc.

ROOM 100
LOWRY HALL
Clemson University
Clemson, South Carolina

Dr. Herbert W. Busching
Associate Professor and Head
Department of Civil Engineering
Clemson University
Clemson, South Carolina 29631

February 10, 1970

Re: Composite Materials Film Project

Dear Dr. Busching:

Thank you for your letter of February 6 retaining our firm to work with you on your composite materials film project. I am delighted that you chose our group for this project; I am certain that we will be able to produce a very satisfactory and educational film.

Following your request, I am listing below the sequence I feel should be utilized to best develop the subject matter.

The first point which comes to my mind is a definition of exactly what a composite material is; this could lead naturally into some examples. Composites found in nature would be listed first: bamboo (or any wood), and bone would suffice as examples of these. Next, man-made composites which the audience may be familiar with could be discussed. Plywood, rubber hose found on the radiator and heater of most American automobiles, fiberglass chairs, golf balls, and telephone transmission lines are examples well known to everyone. Photographs, or the materials themselves, could be shown to illustrate exactly what composite materials are. This discussion leads naturally to why composites are important. The advantages of using composites would now be brought up.

First, it should be pointed out that the high-strength form of a material is in fibers or whiskers. (The definition of a whisker would be necessary at this time.) A graph of tensile strength versus fiber diameter could be used to show the inverse relationship which exists.

Exhibit A-6. Reply to letter assignment (Exhibit A-5) from Mr. McArdle, civil engineering undergraduate student

Tests of different diameter fibers could be run on the universal testing machine to illustrate the results shown plotted on the graph. Only one test should be run on film, due to the time involved. The other tests could be run before filming, and only the results shown in the movie.

Second, how resistance to crack propagation is enhanced by fibers could be illustrated. Several tests could be made showing beams with and without fibers. Plastic beams with a crack "built into" the material could be used to show how cracks advance through a substance. Next, beams with fibers would be used to show how the fiber retards crack propagation.

A third point would be how two materials are combined to improve certain properties. A nonconductor may be combined with a conductor to improve electrical properties. Two materials may be combined to produce a third material that is higher in strength than either material alone, and yet it is relatively lightweight. As a side note, pictures or drawings could be presented to show future structural possibilities using composite materials. The Architecture Department could be of some help along this line.

After illustrating the advantages of composites, I think it only appropriate to mention some of the disadvantages, or rather, the problems presently associated with composite materials.

Certainly, one problem associated with composites is concerned with making the material a composite to begin with; there are problems of bonding and adhesion which must be overcome. One good example which is probably familiar to most people is plywood. The piece of plywood one purchases at the local hardware store is only as good as the glue holding the sheets together. Illustrations would be helpful here.

Secondly, holes, notches, discontinuities, and so forth are difficult to form in composite materials.

Third, control over orientation and distribution of fibers in the matrix is important, and a problem with composites.

Fourth, cost and quality control is a problem; fibers are very expensive to produce, especially whiskers, and quality control is very difficult to obtain. The last three topics above would be discussed by the narrator with charts or graphs to make the points clear.

The above outline is rather sketchy, I realize. Basically, I believe the film should remain as simple as possible with three major parts: 1) Introduction. Composites are defined and examples are given. 2) Advantages. Reasons are given as to why composites have become so popular recently. Tests or experiments illustrate this. 3) Problems encountered with composites are given. Parts 1 and 3 above should be about 4-5 minutes each, with part 2 comprising the bulk of the film.

There are two topics our group would be interested in. The first is photoelastic stress analysis, especially the study of stress concentrations around holes; however, I understand another group has already been contracted to carry out this particular phase of the project. An alternate project would be to take glass rods and perform three basic operations to strengthen them: quenching, fire polishing, and treatment with acid. The beams will be tested before and after treatment. The test would be a flexure test using a universal testing machine. (Tension tests would not be possible because the jaws required to clamp the glass rods would induce cracks in the glass.) I have discussed this with Mr. G. C. Robinson, Head of the Ceramic Engineering Department at Clemson University. He says he has the equipment to do all the tests, and he also informs me that he can procure the glass rods necessary. On this, however, he will need two weeks advance notice. The tests, of course, would illustrate the surface flaws present in all glass. These are what reduces the strength. An analogy could then be drawn for glass fibers in composite materials. We could discuss why these are coated before being placed in the matrix. I would like to discuss this with you further at a later date, and in considerable more detail than is presented here. Perhaps you could meet with our group during the afternoon of February 13.

Again, I appreciate your invitation to work with you on this project. I hope you will consider our proposals, and let us hear from you at the earliest possible date, so we can proceed with our plans for setting up the proper testing equipment.

Very truly yours,

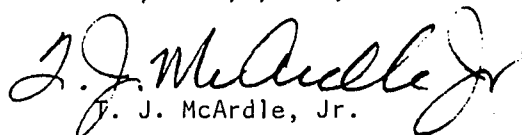
F. J. McArdle, Jr.

TJM/fw

CLEMSON UNIVERSITY
CLEMSON, SOUTH CAROLINA 29631

COLLEGE OF ENGINEERING
DEPARTMENT OF CIVIL ENGINEERING

February 17, 1970

TELEPHONE 656-3001
AREA CODE 803

Mr. T. J. McArdle, Jr.
CE 320 Students, Inc.
Department of Civil Engineering
Clemson University
Clemson, South Carolina 29631

Dear Mr. McArdle:

Thank you for your letter of February 10 advising me of your firm's interest in working on our film project. I certainly appreciate your comments and suggestions regarding the overall treatment of the film.

The topics which your group wishes to work on were well documented and I believe your firm would do a professional job in filming these topics. I hope you will be able to obtain the glass rods which you need for experimental work and I am glad you have discussed problems that may arise with Prof. Robinson.

I am looking forward to working with your firm and I hope you will feel free to contact Mr. Kammoun or me if we can be of assistance to you.

Very truly yours,

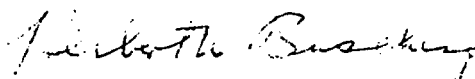

Herbert W. Busching
Associate Professor and Head

HWB/fw

Exhibit A-7. Individual reply similar to those sent to students who answered the letter assignment (Exhibit A-5).