

NBSIR 82-2532

Further Development of A Test Method for the Assessment of the Acute Inhalation Toxicity of Combustion Products

**U.S. DEPARTMENT OF COMMERCE
National Bureau of Standards
National Engineering Laboratory
Center for Fire Research
Washington, DC 20234**

June 1982

Report



**U.S. DEPARTMENT OF COMMERCE
NATIONAL BUREAU OF STANDARDS**



NBSIR 82-2532

**FURTHER DEVELOPMENT OF A TEST
METHOD FOR THE ASSESSMENT OF THE
ACUTE INHALATION TOXICITY OF
COMBUSTION PRODUCTS**

Barbara C. Levin, Andrew J. Fowell, Merritt M. Birky,
Maya Paabo, Alan Stolte, Dolores Malek

U.S. DEPARTMENT OF COMMERCE
National Bureau of Standards
National Engineering Laboratory
Center for Fire Research
Washington, DC 20234

June 1982

Report

U.S. DEPARTMENT OF COMMERCE, Malcolm Baldrige, *Secretary*
NATIONAL BUREAU OF STANDARDS, Ernest Ambler, *Director*

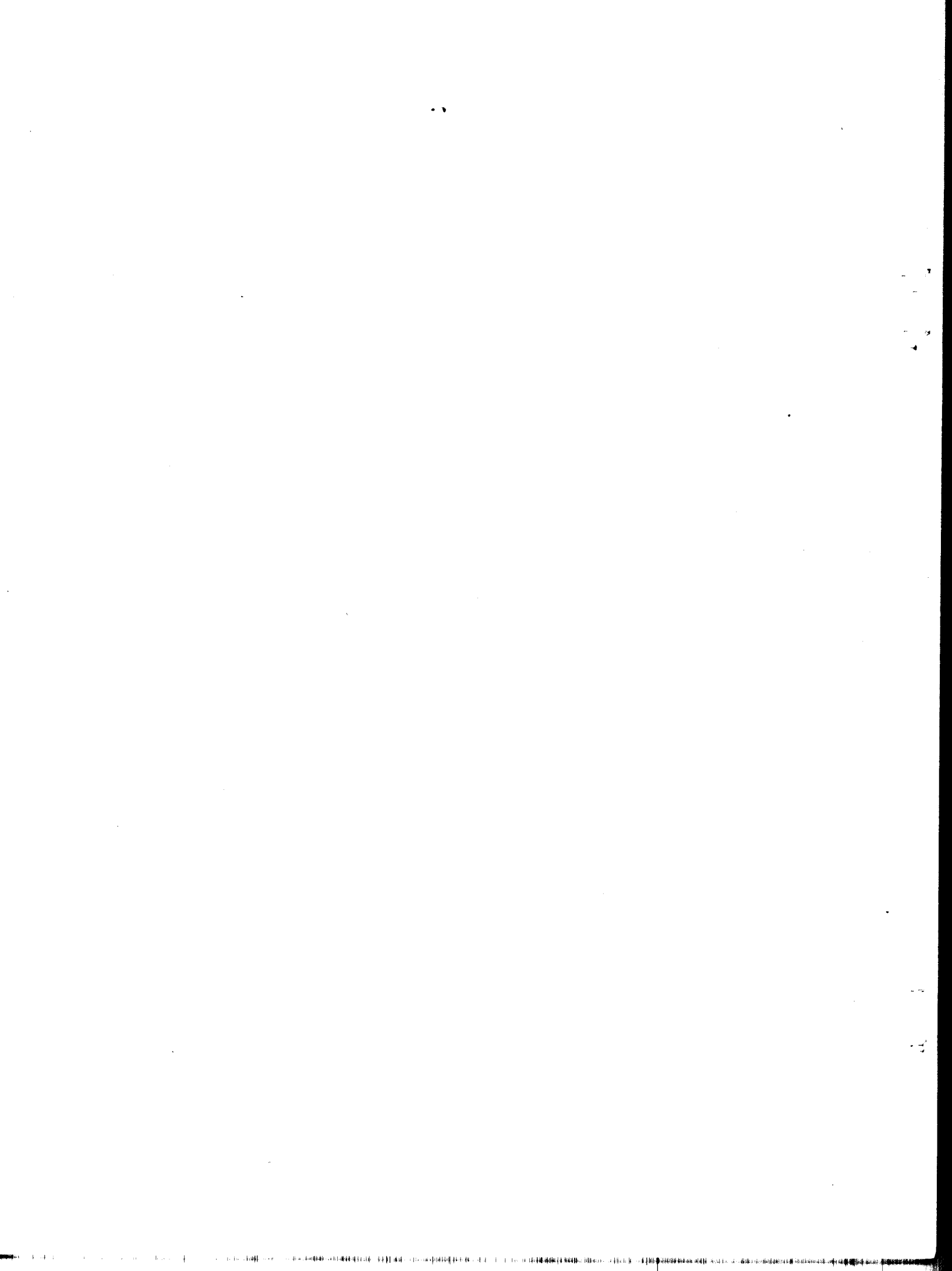



UNITED STATES DEPARTMENT OF COMMERCE
National Bureau of Standards
Washington, D.C. 20234

MEMORANDUM FOR Recipients of NBSIR 82-2532, Further Development of
A Test Method for the Assessment of the Acute
Inhalation Toxicity of Combustion Products

Subject: Clarification

NBSIR 82-2532, Further Development of A Test Method for the Assessment of the Acute Inhalation Toxicity of Combustion Products, notes that this test method *is primarily intended for research and preliminary screening purposes*. The phrase *preliminary screening purposes* refers to use by product researchers and materials manufacturers in developing and evaluating materials. The test method is not intended to be used by itself in evaluating the fire safety of a material since additional factors must be considered for a given situation. The report specifically notes these factors in sections 2.2.2 and 2.2.3:

2.2.2 Additional factors that must be considered in evaluating the toxic hazard posed by a material in a given situation include, among others: the quantity of material present, its configuration, the proximity of other combustibles, the volume of the compartments to which the combustion products may spread, the ventilation conditions, the ignition and combustion properties of the material(s) present, the presence of ignition sources, the presence of fire protection systems, and the building occupancy.

2.2.3 Therefore, the results of this test method must be combined with other pieces of information if making decisions about the suitability of materials for specified uses.



CONTENTS

	Page
LIST OF FIGURES	v
LIST OF TABLES.viii
Abstract.	x
1.0 INTRODUCTION	1
2.0 A TEST METHOD FOR THE ASSESSMENT OF THE ACUTE INHALATION TOXICITY OF COMBUSTION PRODUCTS.	4
2.1 Scope	4
2.2 Significance and Use.	5
2.3 Definitions	6
2.4 Applicable Documents.	7
2.5 Summary of Test Method.	8
2.6 Apparatus	8
2.7 Calibration	13
2.8 Animal Care	13
2.9 Test Specimen	13
2.10 Test Procedure.	15
2.11 Reporting	19
2.12 Test Method Sensitivity and Limitations	21
2.13 Safety Considerations	22
3.0 COMBUSTION SYSTEM.	23
3.1 Introduction.	23
3.2 Static Versus Dynamic Combustion System	23
3.3 Radiant Versus Convective Heat.	24
3.4 Preset Exposure Temperatures or Ramped Temperatures	26
3.5 One Temperature or Different Temperatures for all Materials	27
3.6 Flaming and Non-Flaming Conditions.	28
3.7 Sample Preparation.	30
3.8 Pressure-Relief Panel	32
3.9 Summary of Combustion System.	32
4.0 ANIMAL EXPOSURE SYSTEM	33
4.1 Criteria for an Exposure System	33
4.2 Whole Body Versus Head-Only Exposure of the Animals	33
4.3 Static Exposure Versus Dynamic Exposure	34
4.4 Exposure Chamber Design	37
4.5 Exposure Duration	39
4.6 Summary of Animal Exposure System	39
5.0 CHEMICAL MEASUREMENTS.	40

	Page
5.1 Need	40
5.2 Instrumentation.	41
5.3 NBS Results.	44
5.4 Summary of Chemical Measurements	46
6.0 ANIMAL MEASUREMENTS	47
6.1 Need for Animals	47
6.2 Test Animals	48
6.3 Biological Endpoints	50
6.4 Assessment of Materials that Release Toxicants Rapidly	60
6.5 Summary of Animal Measurements	62
7.0 BIOLOGICAL MEASUREMENTS	63
7.1 Blood Analysis	63
7.2 Correlation of COHb, CO, and Toxicity.	65
8.0 SUMMARY OF CHANGES TO THE TEST METHOD	66
9.0 FUTURE WORK	68
10.0 ACKNOWLEDGMENTS	69
11.0 REFERENCES.	70

LIST OF FIGURES

	Page
Figure 1. Exposure chamber.	74
Figure 2. Details of exposure chamber.	75
Figure 3. Pyrolysis/combustion furnace.	76
Figure 4. Schematic of animal restrainer.	77
Figure 5. Exposure chamber with separate furnace.	78
Figure 6. Radiant furnace cone.	79
Figure 7. Animal restrainer.	80
Figure 8. NBS exposure chamber temperatures at animal nose levels. Top: maximum temperatures. Bottom: average temperatures.	81
Figure 9. Chamber temperature at animal nose positions during 30 minute exposure to flaming wool and Douglas fir. (NBS data. Furnace temperature for flaming wool was 675°C and for flaming Douglas fir was 490°C.)	82
Figure 10. Schematic of NBS gas analysis system.	83
Figure 11. Carbon monoxide measurements averaged over the 30 minute <u>flaming</u> material decomposition plotted against the mass loading/chamber volume. The length of least squares linear regression line denotes the range of mass loadings tested.	84
Figure 12. Carbon monoxide measurements averaged over the 30 minute <u>non-flaming</u> material decomposition plotted against the mass loading/chamber volume. The length of the least squares linear regression line denotes the range of mass loadings tested.	85
Figure 13. Hydrogen cyanide measurements averaged over the 30 minute <u>flaming</u> material decomposition plotted against the mass loading/chamber volume. The length of the least squares linear regression analysis line denotes range of mass loadings tested.	86
Figure 14. Hydrogen cyanide measurements averaged over the 30 minute <u>non-flaming</u> material decomposition plotted against the mass loading/chamber volume. The length of the least squares linear regression analysis line denotes range of mass loadings tested.	87

	Page
Figure 15. Overloading of furnace capacity as seen with non-flaming decomposition of Douglas fir in the NBS large furnace. Small furnace had similar results.	88
Figure 16. Overloading of furnace capacity as seen with flaming decomposition of Douglas fir in the NBS small furnace. Similar results were seen with large furnace.	89
Figure 17. Carbon monoxide generation from ILE materials decomposed in the non-flaming mode at various mass loadings (NBS results).	90
Figure 18. Hydrogen cyanide generation from ILE nitrogen-containing materials decomposed in the non-flaming mode at various mass loadings (NBS results).	91
Figure 19. Hyperbola depicting asymptotes approaching a threshold mass loading at 30 minutes and a threshold time-to-incapacitation.	92
Figure 20. Time-to-incapacitation vs mass loading/chamber volume hyperbolas for Douglas fir in the non-flaming mode from six laboratories. (Symbols refer to the mean and standard deviation of the times-to-incapacitation of the 6 animals tested at each mass loading.)	93
Figure 21. Concentration-response curves resulting from animal incapacitation, death within exposure (30 min) and death both within and post-exposure (30 min + 14 days) from the thermal decomposition of wool in the flaming mode.	94
Figure 22. Concentration-response curves depicting importance of slope information, i.e., LC ₅₀ data are the same, but the effective concentration range differs.	95
Figure 23. Comparison of materials by their EC ₅₀ , LC ₅₀ (30 min) and LC ₅₀ (30 min + 14 days) after <u>flaming</u> decomposition (NBS data). (Symbols referring to the same material are connected by lines for easier identification and not to imply a mathematical functional relationship.)	96

	Page
Figure 24. Comparison of materials by their EC ₅₀ , LC ₅₀ (30 min) and LC ₅₀ (30 min + 14 days) after <u>non-flaming</u> decomposition (NBS data). (Symbols referring to the same material are connected by lines for easier identification and not to imply a mathematical functional relationship.)	97
Figure 25. Three dimensional representation of the relationship between concentration, time, and lethality. (Figure modified after Packham and Hartzell [24].)	98
Figure 26. Within- and post-exposure changes in carboxy-hemoglobin and oxyhemoglobin in live cannulated rats after a 30 minute exposure to an average concentration of 4100 ppm of carbon monoxide.	99
Figure 27. Effect of blood sampling before end of exposure (cannulated animals) and after exposure (non-cannulated animals). Results from Douglas fir in the non-flaming mode from seven laboratories.	100
Figure 28. Determination of percent carboxyhemoglobin at EC ₅₀ , LC ₅₀ (30 min), and LC ₅₀ (30 min + 14 days) from blood values obtained at various mass loadings. (NBS data from flaming red oak.)	101
Figure 29. Relationship between carboxyhemoglobin and carbon monoxide at the LC ₅₀ (30 minutes + 14 days) for eleven materials (NBS data).	102

LIST OF TABLES

	Page
Table 1. Participants of the Ad Hoc Working Group.	103
Table 2. List of Materials.	105
Table 3. Interlaboratory Evaluation of Douglas Fir.	106
Table 4. Modification of the Experimental Procedure.	107
Table 5. Toxicity of Modacrylic at Different Temperatures.	108
Table 6. Single Versus Multiple Pieces of Douglas Fir.	109
Table 7. Maximum Chamber Temperatures During Animal Exposures.	110
Table 8. NBS Carbon Monoxide Production per Unit $\frac{\text{Mass Loading}}{\text{Chamber Volume}}$.	111
Table 9. NBS Carbon Dioxide Production per Unit $\frac{\text{Mass Loading}}{\text{Chamber Volume}}$.	112
Table 10. NBS Hydrogen Cyanide Production per Unit $\frac{\text{Mass Loading}}{\text{Chamber Volume}}$.	113
Table 11. Minimum Average Oxygen Concentrations.	114
Table 12. Incapacitation Times After Exposure to Non-Flaming PVC.	115
Table 13. Constants for Time-Concentration Hyperbolas ($Y = Q + R/X$).	116
Table 14. EC_{50} Values in mg/l.	117
Table 15. Slopes of EC_{50} Concentration-Response Curves.	118
Table 16. LC_{50} (30 minutes) values in mg/l.	119
Table 17. LC_{50} (30 minutes + 14 days) in mg/l (95% Confidence Limits).	121
Table 18. Slopes of LC_{50} , 30 Minutes (95% Confidence Limits of Slope).	123
Table 19. Slopes of LC_{50} , 30 Minutes + 14 Days (95% Confidence Limits of Slope).	125

	Page
Table 20. Comparison of NBS EC ₅₀ and LC ₅₀ Values.	127
Table 21. Comparison of the Normalized Flaming LC ₅₀ and EC ₅₀ Data from all Laboratories.	128
Table 22. Comparison of the Normalized Non-Flaming LC ₅₀ and EC ₅₀ Data from all Laboratories.	129
Table 23. Comparison of the Normalized LC ₅₀ and EC ₅₀ Data at 440°C from all Laboratories.	130
Table 24. NBS 10 Minute Test @ 30 mg/l.	131
Table 25. Carboxyhemoglobin and Gas Concentration Values at LC ₅₀ (30 min + 14 days) - Flaming Combustion.	132
Table 26. Carboxyhemoglobin and Gas Concentration Values at LC ₅₀ (30 min + 14 days) - Non-Flaming Combustion.	133

FURTHER DEVELOPMENT OF A TEST METHOD FOR THE ASSESSMENT OF
THE ACUTE INHALATION TOXICITY OF COMBUSTION PRODUCTS

Barbara C. Levin, Andrew J. Fowell, Merritt M. Birky*,
Maya Paabo, Alan Stolte, Dolores Malek**

Abstract

This report describes the development of a test method for the assessment of acute inhalation toxicity of combustion products of materials. The procedure is primarily intended for research and screening purposes. It provides: 1) a method for determining, under flaming and non-flaming conditions, an LC₅₀ (the concentration of combustion products which causes 50% lethality in the test animals (rats) exposed for 30 minutes and observed for 14 days following exposure); 2) an optional procedure to examine materials which rapidly produce combustion products which cause death of test animals within a 10 minute exposure and a 14 day post-exposure observation period; and 3) a description of analytical and physiological measurements which can provide more detailed information on the nature of the toxic effects of combustion products. Limitations of the test method are identified and future work to address them is proposed.

The participation through the direct exchange of technical information of organizations representing academia, industry, and other agencies of the United States Government is acknowledged.

Key Words: combustion products; flaming combustion; inhalation;
materials; non-flaming combustion; test method; toxicity.

* Current address: The Foundation for Fire Safety, Suite 1508, 1700
North Moore Street, Rosslyn, VA 22209.

**Guest Worker: Physiology Dept., School of Medicine and Health Sciences,
The George Washington University, Washington, D.C. 20006.
Current address: Graduate School of Public Health, University of
Pittsburgh, Pittsburgh, PA 15261.

FURTHER DEVELOPMENT OF A TEST METHOD FOR THE ASSESSMENT OF
THE ACUTE INHALATION TOXICITY OF COMBUSTION PRODUCTS

1.0 INTRODUCTION

The United States and Canada have higher fire fatality rates than any of the other industrialized countries from which comparable data are collected [1]¹. In 1979, the U.S. had 7800 reported fatalities, 31,000 people injured and over 5 billion dollars in property damage due to fires [2].

Most fire deaths occur in homes from either smoldering combustion or a large, flaming room fire. Eighty percent of these deaths are due to the inhalation of smoke or hot gases and are not a result of burns. Carbon monoxide has been imputed to be the primary cause of these fatalities. However, the production of other toxicants in addition to carbon monoxide during the thermal decomposition of materials prompted the National Bureau of Standards to develop a method of assessing the toxicity of combustion products. Requests to develop a test method came from model code officials who had provisions in their codes controlling production of fire gases but no test methods to assess the toxicity of combustion products, and from industry which had no means of screening their products.

Extensive state-of-the-art reviews of the hazards of smoke inhalation were sponsored by the National Aeronautics and Space Administration in 1977 [3] and by the National Academy of Sciences in 1978 [4]. Also in 1977, the National Academy of Sciences published a review of factors to be considered when evaluating the toxicity of pyrolysis and combustion products [5]. These reviews have been influential in the evolution of this test method.

¹Numbers in brackets refer to the literature references listed at the end of this report.

The early development of this test method was supported by the Products Research Committee (PRC) which was formed in 1974 by the Federal Trade Commission and twenty-five representatives from the cellular plastics industry [6]. The committee consisted of members with expertise in the scientific, engineering, and commercial aspects of cellular plastics and were selected from academia, industry, and government. The mission of the PRC was to administer a research program through grants to investigate the behavior of cellular plastics in fire, especially in areas of fundamental research, small and large scale testing, and toxicity of combustion products. Under the sponsorship of the PRC, a small-scale test procedure consisting of a combustion system, a chemical analysis system, and an animal exposure system was designed and tested. The results of this early work have been published as a report of the National Bureau of Standards [7].

An interagency governmental meeting was held by NBS in January 1976 to examine the concerns and programs of various agencies in the area of combustion toxicology. The objective of this initial planning meeting was to focus on the needs of the agencies and to avoid unnecessary duplication of efforts within the government. Agencies represented at this initial meeting were the Consumer Product Safety Commission (CPSC), Department of Defense (DOD), Department of Transportation (DOT), Environmental Protection Agency (EPA), Energy Research and Development Administration (ERDA), Federal Aviation Administration (FAA), National Aeronautics and Space Administration (NASA), National Bureau of Standards (NBS), National Center for Toxicological Research (NCTR), National Institute of Environmental Health Services (NIEHS), and the National Institute for Occupational Safety and Health (NIOSH).

An ad hoc working group was formed by NBS in November 1977 consisting of members from approximately 20 academic, industrial, or government organizations engaged in work relevant to the subject area. The purpose of this group was to provide a forum for exchanging technical information to assist the National Bureau of Standards in the development

of a small-scale laboratory test to assess the inhalation toxicity of combustion products. The organizations that participated and their representatives are listed in table 1. The National Bureau of Standards is grateful for the helpful advice, time, and expense that the members of the working group donated in their efforts towards the development of this test method. The acknowledgment, however, of the participating organizations is not intended to imply endorsement of the test method by those organizations.

Seven members of the ad hoc working group participated in an inter-laboratory evaluation (ILE) of the test method proposed originally. (The original method, in Appendix A of reference [7], should be distinguished from the method presented in section 2 of the present report. The earlier method was evaluated in the ILE and resulted in the procedure of section 2. (See section 8 for a summary of the changes.) The objectives of the ILE were to determine the operability of the procedure and to determine the reproducibility of the test results from different laboratories. Twelve materials (table 2), representing a wide variety of products (both natural and synthetic), were examined by the participants in the ILE. The detailed description and results of the ILE will be presented in a report titled "The Interlaboratory Evaluation of the NBS Toxicity Test Method" (NBS report, in preparation). Some of the ILE data are also presented in this report for illustrative purposes.

Throughout the development of the test method, the experimental results from the participants of the ILE were presented at the ad hoc working group meetings to help solve technical issues pertaining to the methodology of the test. In addition, other members of the ad hoc working group who were using other experimental systems also tested many of the 12 materials. The consequence of this continuous input of data on the identical materials was that the proposed method being tested by the ILE was not a static procedure, but rather an evolving one.

The resulting test method, which is presented in section 2 of this document, provides a means of assessing the acute inhalation toxicity of the combustion products of materials under specified laboratory conditions and is primarily intended for research and preliminary screening purposes. Additional factors must be considered in evaluating the potential toxic hazard posed by a material in a given situation. Some of these factors are listed in the section of the test method pertaining to significance and use. Therefore, the results of this test method must be combined with other information when making decisions about the suitability of materials for specified uses.

In what follows, the resultant test method is described in section 2 and the rationale for the key provisions is discussed in detail in the following sections.

2.0 A TEST METHOD FOR THE ASSESSMENT OF THE ACUTE INHALATION TOXICITY OF COMBUSTION PRODUCTS

2.1 SCOPE

2.1.1 This laboratory test method is designed to assess the acute inhalation toxicity of products resulting from the combustion or other thermal degradation of materials.

2.1.2 Measurements are made under conditions of flaming combustion and non-flaming pyrolysis, which are two key degradation modes encountered in fires.

2.1.3 The test procedure provides a method for determining an LC_{50} , the amount of material which produces sufficient combustion products to cause 50% lethality in the test animals (rats) during a 30 minute exposure and a 14 day post-exposure observation period. The experimental results include the concentration-response curve and its slope.

2.1.4 The test method also describes an optional means to examine materials which at a 30 mg/l mass loading/chamber volume produce concentrations of combustion products that cause death within a 10 minute exposure and a 14 day post-exposure observation period.

2.1.5 Additional analytical and physiological measurements are described which can provide more detailed information on the nature of the toxic effect.

2.2 SIGNIFICANCE AND USE

2.2.1 The test method provides a means of assessing the acute inhalation toxicity of the combustion products of materials under specified laboratory conditions and is primarily intended for research and preliminary screening purposes.

2.2.2 Additional factors that must be considered in evaluating the toxic hazard posed by a material in a given situation include, among others: the quantity of material present, its configuration, the proximity of other combustibles, the volume of the compartments to which the combustion products may spread, the ventilation conditions, the ignition and combustion properties of the material(s) present, the presence of ignition sources, the presence of fire protection systems, and the building occupancy.

2.2.3 Therefore, the results of this test method must be combined with other pieces of information if making decisions about the suitability of materials for specified uses.

2.2.4 The analytical and biological measurements can provide improved understanding of the mechanisms of toxic action. Such information will be helpful in determining the need for further research on specific materials.

2.2.5 The test procedure provides a uniform method of reporting combustion toxicity data developed under laboratory conditions. This will facilitate communication between workers in the field, promote progress in research, and aid in the establishment of a self-consistent data base of combustion product toxicity information.

2.2.6 The thermal exposure conditions employed in the test represent severe fire situations but do not simulate all possible fire scenarios.

2.3 DEFINITIONS

Definitions specific for this test:

2.3.1 Acute Toxicity: harmful effects of a single short exposure to combustion products generated by the thermal degradation of materials.

2.3.2 Toxic Hazard: material and environmental conditions which increase the probability that a toxic atmosphere will occur and an injury will result.

2.3.3 Mass Loading: amount of material loaded in furnace in grams.

2.3.4 Concentration: mass loading per unit of exposure chamber volume, expressed in mg/l.

2.3.5 Concentration-response: concentration plotted against the percentage of animals that die during the 30 minute exposure and 14 day post-exposure period.

2.3.6 LC₅₀: concentration that is determined statistically to produce death in 50% of the test (animal) population exposed for 30 minutes and observed for a period of 14 days.

2.3.7 Auto-ignition Temperature: the lowest furnace temperature at which a material sample introduced into the test furnace will spontaneously ignite within 30 minutes.

2.4 APPLICABLE DOCUMENTS

2.4.1 Birky, M.M.; Paabo, M.; Levin, B.C.; Womble, S.E.; Malek, D. Development of a recommended test method for toxicological assessment of inhaled combustion products. (U.S.) NBSIR 80-2077; 1980, Sept. 63p.

2.4.2 Good Laboratory Practices. Federal Register, 43: 59986; 1978, Dec. 22.

2.4.3 Irwin, S. Comprehensive observational assessment: IA. A systematic, quantitative procedure for assessing the behavioral and physiologic state of the mouse. Psychopharmacologia, 13: 222-257; 1968.

2.4.4 Litchfield, J.T., Jr; Wilcoxon, F. A simplified method of evaluating dose-effect experiments. J. Pharmacol. and Exp. Therapeut, 96: 99-113; 1949.

2.4.5 Lyons, J.W.; Fristrom, R.M.; Becker, W.E.; Clayton, J.W.; Emmons, H.W.; Glassman, I.; Graham, D.L.; Long, R.; McDonald, D.W.; Nadeau, H.G. Fire research on cellular plastics: The final report of the Products Research Committee. Washington, D.C., 1980, 213p.

2.4.6 MacFarland, H.N. Respiratory toxicology, chapter 5 in Essays in Toxicology, W. Hayes, ed. New York: Acad. Press; 7: 121-154; 1976.

2.4.7 Packham, S.C.; Frens, D.B.; McCandless, J.B.; Petajan, J.H.; Birky, M.M. A chronic intra-arterial cannula and rapid microtechnique for carboxyhemoglobin determination. J. Comb. Tox. 3: 471-478; 1976.

2.4.8 Potts, W.J.; Lederer, T.S. A method for comparative testing of smoke toxicity. J. Comb. Tox. 4: 114-162; 1977.

2.4.9 Standard guide for measurement of gases present or generated during fires. ASTM Standard E 800-81; 1981.

2.4.10 Committee on Fire Toxicology. Fire toxicology: methods for evaluation of toxicity of pyrolysis and combustion products. Report No. 2, Nat. Acad. Sci., Washington, D.C., 1977 August, 34 p.

2.5 SUMMARY OF TEST METHOD

2.5.1 A small scale laboratory test method has been developed to assess the acute toxicity resulting from the inhalation of the products of materials combusted or thermally degraded under specified conditions.

2.5.2 The test apparatus consists of 3 major components: (1) a combustion system, (2) a chemical analytical system, and (3) an animal exposure system. The toxicity of the combustion products is determined after pyrolyzing or burning small samples of materials at two decomposition temperatures, one flaming mode and one non-flaming mode. The temperature and the oxygen concentration in the chamber are monitored and kept within specified limits in order to prevent an additional significant contribution to the toxicological insult. An additional test at a specified temperature under non-flaming conditions may be used.

2.5.3 Lethality is the principal biological end-point obtained from these experiments, and results are expressed as: (1) the LC_{50} calculated from the percent lethality which occurs during a 30 minute exposure and a 14 day post-exposure observation period and, optionally, (2) the percent lethality which occurs during a 10 minute exposure and 14 day post-exposure period which results from a specific concentration of combustion products of 30 mg/l.

2.6 APPARATUS

2.6.1 Animal Exposure Chamber.

2.6.1.1 A nominal two hundred liter animal exposure chamber including a small combustion furnace, as shown schematically in figure 1, shall be used.

2.6.1.2 The exposure chamber shall be made of 1.2 cm (0.5 inch) clear polymethylmethacrylate with inside dimensions of 122 x 36 x 46 cm (48 x 14 x 18 inches). Six animal ports are positioned, as shown in figure 1, and are constructed of polymethylmethacrylate tubing 6.3 cm (2.5 inch) I.D. having a 0.3 cm (1/8 inch) wall thickness.

2.6.1.3 A blow-out panel should be provided in the top of the exposure chamber on the right side away from the furnace to provide pressure relief in case of an explosion (fig. 1).

2.6.2 Cup Furnace (Note 1).

2.6.2.1 The furnace must be capable of operating up to 800°C and be controlled to $\pm 10^\circ\text{C}$. The furnace is connected to the bottom of the exposure chamber under the stainless steel plate (fig. 2) which contains a cooling coil through which cold water is continuously run throughout all experiments. Details of the furnace are shown in figure 3 (Note 2).

2.6.2.2 A quartz beaker, 9 cm I.D. by 15 cm high, is inserted into the furnace after the furnace is connected to the exposure chamber.

2.6.2.3 For flaming combustion an electrically heated wire or other electrical ignition source is used to ignite the products as they exit from the furnace. The ignition coil is only used to insure ignition of

Note 1: For composite materials and some end use products with layered construction where exposed surface area is a major factor, a radiant heating system including a load cell to measure sample weight loss may have a number of advantages over the cup furnace. Such a radiant heating system is currently being explored as an alternative combustion module. See section 2.9.2.2.

Note 2: A furnace and controller meeting this requirement are commercially available from Thermcraft, Inc., Winston Salem, N.C., as model no. 375-A-1183.*

*Certain commercial equipment, instruments, or materials are identified in this paper in order to adequately specify the experimental procedure. In no case does such identification imply recommendation or endorsement by the National Bureau of Standards, nor does it imply that the equipment or material identified is necessarily the best available for the purpose.

the sample during animal exposure and is not used to establish the auto-ignition temperature of the material. This ignition system is at the top of the quartz beaker.

2.6.3 Analytical Apparatus.

2.6.3.1 Continuous measurements for oxygen (O_2), carbon dioxide (CO_2) and carbon monoxide (CO) are to be made and recorded. (See section 2.4.9 for reference to applicable procedures.) A non-dispersive infrared (IR) technique is suggested for CO and CO_2 . The CO and CO_2 measurement instrumentation should be capable of measuring a range of 0-10,000 ppm with an accuracy of 200 ppm and 0-50,000 ppm with an accuracy of 700 ppm, respectively. Oxygen measurements are to be made with an instrument operating on the magnetic susceptibility or the electrolytic cell principle; it should be capable of measuring a range of 0-25% and an accuracy of $\pm 0.1\%$ O_2 . Alternatively, a gas chromatographic sampling technique may be used, in which case measurements of O_2 , CO_2 , and CO are to be made every two minutes. The average oxygen level in the chamber shall not fall below 16% during the exposure. Oxygen is to be supplied to the chamber as needed to maintain the concentration between 16-21%.

2.6.3.2 The continuous monitoring of O_2 , CO_2 and CO is accomplished by the removal of some of the products from the chamber. A flow of approximately 0.5 liters/min is required for each instrument for analysis of CO_2 , CO, and O_2 . During a 30 minute exposure, this amounts to 15 liters per analyzer that is removed, analyzed, and pumped back into the chamber. Oxygen should be added as needed depending on the degree of O_2 depletion. One must correct the total volume for this addition when calculating the mass loading of combustion products (chamber volume plus added volume at room temperature).

2.6.3.3 The gas sampling port shall be at the animal nose level in the geometric center of the exposure chamber, as shown in figure 2. The gases for the CO, CO_2 , and O_2 analyses are returned to the left side of

the chamber above the furnace. The return tubes should be disconnected during calibration of analytical instruments to prevent the inadvertent accumulation of calibration gases (CO, CO₂, etc.) in the animal chamber.

2.6.4 Temperature Measurements.

The environmental temperature of the chamber should be recorded continuously during the 30 minute exposure. The temperature sensor must be placed in the air at the level of the animals and within 5.0 cm (2 in.) of one animal's nose. (A chromel-alumel thermocouple is recommended for this measurement).

2.6.5 Animal Restrainers.

Animal restrainers designed to permit head only exposures shall be used. A detailed description of one type of animal restrainers meeting this requirement is given in figure 4.

2.6.6 Biological Measurements.

2.6.6.1 During the 30 minute exposure period, observations of the animal behavior should be noted and recorded. Any unusual behavioral activity should be recorded along with the time.

2.6.6.2 The percent carboxyhemoglobin (COHb) is to be measured in two of the six exposed animals. If the animals are cannulated, the blood should be taken before the exposure (0 time, control blood) and just before the end of the exposure (approximately 29 minutes). Cannulation must be done 24 hours prior to exposure according to the procedure of Packham et al. (see section 2.4.7 for reference). If non-cannulated animals are used to measure COHb, the blood must be taken within 5 minutes of death or the end of the 30 minute exposure. The blood may be obtained via cardiac puncture, intraorbital venous puncture or from the dorsal aorta. Any animals used to obtain blood must be sacrificed following the exposure and not kept for the 14 day post-exposure period.

2.6.6.3 Lethality, which include deaths during the 14 day post-exposure period, is evaluated as a function of the mass loading to construct a concentration-response curve from which the LC_{50} and slope of the concentration-response curve are calculated. The LC_{50} with the 95% confidence limits and the slope of the concentration-response curve should be obtained via an appropriate published statistical method, such as that of Litchfield and Wilcoxon (Note 3) [see section 2.4.4 for reference].

2.6.6.4 For materials that have an LC_{50} of 2 mg/l or greater, lethality resulting from a 10 minute exposure to the decomposition products of materials at a mass loading/chamber volume of 30 mg/l may be measured. This optional 10 minute test is to identify materials which rapidly produce concentrations of combustion products that cause death within the 10 minute exposure and a 14 day post-exposure period.

Note 3: To calculate a statistically valid LC_{50} , at least three concentrations producing responses between 0% and 100% must be tested. To determine these three concentrations may require more than three experiments. For some materials, the investigator may be unable to determine three concentrations producing effects between 0 and 100%, i.e., a 0.5 mg/l difference in concentration changes the percent response from 0 to 100%. In this case, the LC_{50} may be estimated from the linear graph of the percent lethality for each concentration for a given thermal condition versus the concentration of the combustion products. All deaths that occur during the exposure and 14 day post-exposure period must be included in this estimate. The results should indicate the concentrations used to estimate the LC_{50} .

Post-exposure deaths which occur seven or more days following the exposure may be due to a pulmonary infection. If this is suspected, pathological examination of lung tissues should be performed on both exposed and unexposed animals to ascertain whether or not the post-exposure deaths are a result of an infection in the animal colony and not the toxicological insult.

2.7 CALIBRATION

2.7.1 Instrumentation for the measurement of CO, CO₂ and O₂ is to be calibrated before each test using standard gas mixtures of a combination of CO, CO₂ and O₂ in nitrogen.

2.7.2 Instruments used for measurement of carboxyhemoglobin should be calibrated according to manufacturer directions and checked daily.

2.8 ANIMAL CARE

2.8.1 Adult male rats weighing 225-325 grams that are 3-4 months of age shall be used (Note 4). In all cases, normal steps shall be taken to assure that healthy animals are used in testing. It is recommended that 1 rat in 10 be used as a control. Weight change during the 10 day pre-exposure period and 14 day post-exposure period should be measured and recorded. At the end of the 14 day post-exposure period, it is recommended that the control animal be sacrificed and a pathological inspection of the pulmonary system be conducted.

2.8.2 Animals shall be maintained on ad libitum food and water schedules and treated in accordance with Good Laboratory Practices published in the Federal Register (see section 2.4.2 for reference). Animals received from a supplier shall be housed at the testing laboratory for a minimum of 10 days before being used in testing.

2.9 TEST SPECIMEN

2.9.1 Sample Conditioning.

2.9.1.1 Material samples to be evaluated for toxicity should be conditioned in a constant humidity chamber maintained at 50% \pm 10% relative humidity at a room temperature of 22 \pm 3°C for a period of

Note 4: Fischer 344 rats or equivalent are suggested.

48 hours prior to testing. The sample specimen is to be tested in one piece if possible.

2.9.2 Sample Size and Configuration.

2.9.2.1 The size of the test specimen for the initial test will vary depending on the expected toxicity of its combustion products, but will normally be about 5 grams. For example, 5 grams of material thermally degraded leads to a concentration of combustion products of 25 mg/l. Sample sizes for subsequent tests will be selected, based on the results of the initial test, to provide a range of mortalities sufficient to construct a concentration-response curve.

2.9.2.2 Test specimens shall be representative of the materials from which they are taken. Therefore, only pure materials or composite materials of a uniform structure, such as filled materials, can be studied. (Assemblages of non-uniform structure such as carpets or layered wall structures where the response of the material will depend on orientation and the direction of the fire exposure can not be evaluated by the present test.) Whenever possible, the test specimen should be a single piece of the same thickness as the material being tested.

2.9.2.3 Paints, adhesives, etc. shall be applied to glass, allowed to dry and scraped off the glass before weighing and testing.

2.9.2.4 Fabrics, thin films, and flexible cellular materials shall be lightly rolled up and, if necessary, bound with a thin stainless steel wire to maintain a size appropriate for the furnace diameter and depth.

2.10 TEST PROCEDURE

2.10.1 All tests should be conducted in a room or enclosed space having an ambient temperature of $22^{\circ}\text{C} \pm 3^{\circ}$ and relative humidity of $50\% \pm 10\%$ at the time of test.

CAUTION: Provisions must be made for removing combustion products from the exposure chamber without contaminating the work space of the test operators. The exposure chamber should be housed in a chemical hood.

2.10.2 Inside chamber wall surfaces should be cleaned when changing the test material, or temperature of decomposition, or following test runs where toxicologically significant combustion products are suspected of accumulating as particulates, or as visual inspection may indicate.

2.10.3 Combustion Conditions

2.10.3.1 The toxicity of combustion products from the test material is to be determined separately for two conditions: (a) 25°C below auto-ignition (non-flaming) and (b) 25°C above auto-ignition (flaming). An extra, optional test at 440°C (non-flaming) may be used if one desires to compare materials at a single temperature. (The 440°C is 25°C below the average auto-ignition temperature of Douglas fir.) The maximum temperature at which the material is to be tested is 800°C regardless of whether it is flaming or non-flaming.

2.10.3.2 Since the auto-ignition temperature may be dependent on sample size, it is recommended that the sample size used to determine the auto-ignition temperature be the maximum that one anticipates using for toxicity tests since a large size may ignite at a lower temperature.

CAUTION: One should not exceed an 8 gram sample to reduce the risk of creating an explosive mixture.

To determine the auto-ignition temperature, the temperature of the furnace is set at 500°C and when this temperature is attained, the material is introduced into the furnace. If auto-ignition does not occur, the process is repeated at 50°C intervals until the auto-ignition temperature is located. The auto-ignition temperature should be finally determined within 25°C. If auto-ignition does occur at 500°C, the furnace temperature should be decreased in increments until the auto-ignition temperature is bracketed within 25°C. The ignition system mentioned in paragraph 2.6.2.3 should not be used for finding the auto-ignition temperature. When the auto-ignition temperature of the material has been established, the furnace temperature is decreased by 25°C for testing the non-flaming condition (Note 5).

2.10.4 Test Procedure - 30 Minute Exposure.

2.10.4.1 Prior to experiments involving animal exposures, the system should be checked out to determine that the analytical and combustion systems are all operating correctly.

2.10.4.2 To check the entire system, a standard material should be run. This standard should be Douglas fir for which the LC₅₀ data from 7 laboratories for the 30 minute exposure and 14 day post-exposure observation period is shown in table 3. If the LC₅₀ results for the non-flaming and flaming conditions fall within the 95% confidence limits of the mean of these laboratories, the performance of the system will be considered acceptable.

2.10.4.3 Each new material to be tested for toxicity should be used in the system before animals are exposed. This check-out procedure is to determine:

Note 5: Douglas fir has an auto-ignition temperature, as found by the above procedure, of approximately 465°C. As the determination of the auto-ignition temperature depends upon the apparatus and procedure, the auto-ignition temperatures determined by this procedure may differ from those measured according to ASTM D 1929.

- (1) the degree of oxygen depletion during combustion of the sample,
- (2) that the average chamber temperature over the 30 minute exposure period measured at the nose position of the animal does not exceed 40°C (Note 6),
- (3) that the proper conditions have been established for carrying out either non-flaming or flaming combustion exclusively, and
- (4) the estimated mass loading required to produce any deaths (Note 7).

For the flaming test exposure two drops of ethanol can be added to the sample and an electrically heated wire or electric spark used to insure early ignition of the test material. Once these conditions have been established, an experiment involving animals can be initiated.

2.10.4.4 The instruments for CO₂ and CO measurements are zeroed and a base line established during the checkout procedure. Oxygen concentration is also recorded prior to initiation of the exposure.

2.10.4.5 Sample mass loss may be determined by weighing the charged quartz beaker before and after an experiment.

2.10.4.6 The furnace is brought up to the desired temperature and the system allowed to reach equilibrium 10 minutes before the start of the experiment. During this warm-up period and the recording of pre-exposure data, the door of the exposure chamber is left open.

Note 6: The limitation of an average 30 minute temperature not exceeding 40°C is based on results from 12 materials in the NBS chamber. Brief excursions to higher temperatures may occur during periods of active flaming of the sample. At this time, the synergistic or additive effects of temperature and toxicants are not known for animals exposed head only in this system.

Note 7: A CO dose (average CO concentration times 30 minutes) of approximately 100,000 ppm-min is a reasonable rule of thumb to use in estimating the mass loading of a material that leads to lethality. If other toxicants play a significant role in lethality, such as HCN from a nitrogen containing polymer, a 100,000 ppm-min dose will be too high.

2.10.4.7 After these conditions are established, the animals are placed in their positions. To initiate the experiment, the weighed sample is placed in the furnace and the door of the chamber is immediately closed. Placement of the sample into the furnace designates the starting time of the exposure. The animals are then exposed for 30 minutes.

2.10.4.8 If preliminary experiments show that the average temperature in the exposure chamber will exceed the specification in 2.10.4.3, the electrical power to the furnace may be cut off when the sample is completely degraded. The length of time required to degrade a sample which produces CO can be determined by monitoring the increase of CO concentration. For those materials that do not produce CO, another degradation product can be analytically monitored. When the concentration reaches a steady state for 2 minutes, the heater should be shut off.

2.10.4.9 Blood samples are obtained from two animals as rapidly as possible (within 5 minutes) at the end of the exposure (Note 8). The pathological examination of any animals that die during the exposure or are sacrificed immediately after the termination of the exposure is optional. If conducted, it should focus on the condition of the respiratory tract with visual observations recorded of soot deposits, pulmonary edema, and hemorrhagic lungs.

2.10.4.10 Clinical examination of live animals following exposure is optional. While still in the restrainer, the animal's eyes may be examined for reflexes, redness, tearing, corneal opacity; the animal's nose and mouth can be examined for any discharge, and respiratory difficulties (gasping, wheezing, rapid or slow breathing) should be

Note 8: COHb values are a good guide for assessing the significance of CO as the primary toxic agent. Values of COHb \geq 75% generally lead to lethality in some fraction of the animal population. When deaths occur below 75% COHb, the presence of an additional toxicant(s) is indicated.

noted. After removal of the animal from the restrainer, the investigator may examine the animal's exploratory behavior (does the animal explore his surroundings and try to escape), righting reflex (animal is placed on his back and the ability to right himself is scored as rapid, slow or non-existent), and posture (animal is lifted from table by his tail and placed back on table noting irregularities such as limp hind legs).

2.10.4.11 The animals are to be kept for a period of 14 days post-exposure. Any deaths during this time period should be included in the LC_{50} calculations. In addition, note and record any unusual behavior during these days and daily animal weights.

2.10.5 Test Procedure - 10 Minute Exposure

2.10.5.1 The objective of this additional optional test is to determine if materials with a statistically calculated LC_{50} (30 min and 14 days) of greater than 2 mg/l rapidly produce concentrations of combustion products that cause death within a 10 minute exposure and a 14 day post-exposure period when decomposed at a concentration of 30 mg/l. Materials with an $LC_{50} < 2$ mg/l are quite toxic and as a safety precaution should not be tested at 30 mg/l.

2.10.5.2 The procedure in 2.10.4.3 to 2.10.4.6 is repeated.

2.10.5.3 Two separate 10 minute exposures of animals at 30 mg/l are performed using whichever condition (flaming or nonflaming) that gives the lowest LC_{50} concentration. After the 10 minute exposure, the animals are removed from the restrainers and lethality within the exposure or during a 14 day post-exposure observation period is noted. If 50% or more of the animals die during the 10 minutes or 14 days following exposure, this material is considered to produce toxic concentrations of combustion products rapidly.

2.11 REPORTING

2.11.1 Sample:

2.11.1.1 Product description and generic components.

2.11.1.2 Weight before and after test.

2.11.1.3 Temperature and humidity at time of test.

2.11.1.4 Determination of auto-ignition temperature.

2.11.2 Exposure Chamber.

2.11.2.1 Temperature at nose of rats, prior to and during test at two minute intervals.

2.11.2.2 Measurements of the chamber concentration of CO, CO₂, and O₂ continuously or at two minute intervals.

2.11.3 Average temperature of furnace during test.

2.11.4 Animals.

2.11.4.1 Strain of rat and identity of the commercial supplier if one is used.

2.11.4.2 Weight of each animal when received, prior to test, following test, and during post-exposure period (weight to be determined daily).

2.11.5 Observations made during and after exposure, for example, observations on animal posture, righting reflex, exploratory behavior, respiratory function (gaspings, wheezing), grooming, eye and nasal discharge.

2.11.6 For the 10 minute exposure test (if conducted), note percentage of animals who died during test or within 14 days.

2.11.7 Concentration-response curves and LC_{50} for combustion modes of paragraph 2.10.3.1. This includes a concentration-response curve from which a statistically determined LC_{50} value, 95% confidence limits on the LC_{50} , the slope, and 95% confidence limits on the slope are calculated.

2.11.8 COHb, at end of each exposure.

2.12 TEST METHOD SENSITIVITY AND LIMITATIONS

2.12.1 The effectiveness of the test method to determine the acute toxicity of combustion products will depend on the overall reproducibility and repeatability of the test method. A limited interlaboratory study of the operability and reproducibility of the test method has been carried out.

2.12.2 Seven laboratories evaluated the toxicity of the combustion products of Douglas fir in the flaming and non-flaming modes. The resulting LC_{50} values and their 95% confidence limits for each laboratory are recorded in table 3. The mean value and 95% confidence limits for all the laboratories are also given. For Douglas fir in the non-flaming mode, the mean LC_{50} and 95% confidence limits were 22.8 (13.4-32.2) mg/l. In the flaming mode, the mean value was 36.0 (21.1-50.8) mg/l. The Douglas fir results in table 3 should be used as a guide against which laboratories can check the operability of their experimental system.

2.12.3 If a laboratory's LC_{50} results for non-flaming and flaming Douglas fir fall within the 95% confidence limits of the mean values for Douglas fir calculated for the seven laboratories (table 3), the performance of their experimental system should be considered acceptable.

2.12.4 The use of rats to measure the acute inhalation toxicity of combustion products does not imply that a correlation has been established between rats and humans for all toxicants. In spite of this limitation,

which is a limitation in all areas of toxicity testing, an evaluation of toxic effects using animals is the best method available at this time.

2.12.5 The limitations of the cup furnace are:

- (1) the size of the quartz beaker which fits into the furnace limits the quantity of low density materials that can be tested,
- (2) no means is provided for continuously measuring the mass loss of material during the experiment,
- (3) the effect of sample orientation cannot be assessed,
- (4) assemblages of non-uniform structure can not be evaluated, and
- (5) the thermal exposure conditions employed do not represent all possible fire conditions.

2.13 SAFETY CONSIDERATIONS

2.13.1 The test procedure involves the generation of a potentially flammable mixture and toxic products. To prevent the generation of an explosive mixture, no more than 8 grams of material should be degraded by heat in the 200 l chamber. In the case of materials which contain inert fillers and leave non-combustible residues, the sample size may be increased if necessary as long as the weight of combustible fraction charged to the furnace does not exceed 8 grams.

2.13.2 A pressure-relief panel should be provided in the chamber cover opposite the furnace.

2.13.3 The chamber should be operated in a chemical hood (or equivalent) to prevent the contamination of the worker space. Exhausting of the chamber after a test should be carried out in the hood and not by venting into the laboratory environment.

3.0 COMBUSTION SYSTEM

3.1 INTRODUCTION

Generation of combustion products from a wide variety of materials requires a heat source which is controllable over a wide range of temperatures. Ideally, the heat source would simulate the type of thermal energy and temperature exposure that a material would experience in a real fire situation. During the course of a fire, a material may undergo a non-flaming pyrolysis, a self-propagating smoldering decomposition, and/or a flaming combustion. In addition it may be subjected to a varying heat flux. As no single laboratory test could possibly duplicate the infinite number of real fire variations, which are due to both changes in heat flux and available oxygen, only the following alternatives and issues were explored: (1) combustion within the animal exposure chamber (static system) or in a separate chamber (dynamic system), (2) radiant or convective heat, (3) preset exposure temperatures or ramped temperatures, increasing at some fixed rate, (4) a single temperature for every material or various temperatures depending upon the material, (5) flaming and/or non-flaming conditions, (6) the amount of heat generated in the animal exposure chamber by the furnace and (7) the decrease in oxygen concentration during the exposure. As this test is designed only to assess the toxicity of the material's combustion products, issues 6 and 7 are important to insure that the exposed animals do not experience undue heat stress or oxygen deprivation.

3.2 STATIC VERSUS DYNAMIC COMBUSTION SYSTEM

In a static combustion system, the furnace is located such that all the combustion products are generated in the animal exposure chamber where they remain for the duration of the experiment. In a dynamic system, the furnace is located some distance away from the animal exposure chamber and the combustion products are transferred via a pump or a blower. A completely dynamic system allows the products to flow through the chamber and to escape. Examples of dynamic systems are the DIN apparatus which has been described by Kimmerle [8] and the system of Alarie and Anderson [9].

The decision to utilize a static rather than a dynamic combustion system was based on the disadvantages of the larger sample size required by a dynamic system and possible loss of toxicants during transfer. The location of the furnace is shown in figure 2. However, it is important to note that even in the chosen static system at NBS, a continuous sample of the combustion products is transferred from the exposure chamber at a rate of 2 liters per minute through the analytical equipment and returned to the chamber. Water (and possibly some toxicants) and particulates are removed via an ice trap and glass wool filter before the gases are analyzed and returned to the exposure chamber. The animals experience all the combustion products prior to the transfer, but some loss will be experienced during the transfer to and from the analytical equipment (Note 9). One participant in the ILE used a semi-dynamic combustion system, i.e., the furnace was separated from the exposure chamber (fig. 5). Also, in a series of large scale (room-size) smoldering fire tests performed at NBS for comparison with the small-scale toxicity tests, a modification of the semi-dynamic system was used. In this case, when the gas concentration in the room reached a particular predetermined level, the smoke was transferred via a pump from the room of origin to the animal exposure chamber where it was contained for the duration of the exposure. The transfer tubes were kept as short as possible--124 cm long by 10 cm wide. The details of this comparison of the small scale tests with the large smoldering fire tests are to be published soon (Smith, et al., NBS report, in preparation).

3.3 RADIANT VERSUS CONVECTIVE HEAT

Preliminary experiments on two radiant furnaces were conducted at NBS before the start of the ILE. This early work tested a radiant panel furnace consisting of quartz-iodide lamps placed on top of the exposure chamber with the radiation directed through a quartz window at the

Note 9: In the worst case, where all toxicants are removed in the ice trap, the average concentration over the 30 minutes in the exposure chamber would be reduced by 14%.

sample located within the chamber. At the full wattage rating of the lamps, a heat flux of 5 watts/cm² was measured at a distance of 4.5 cm below the quartz window by a radiometer. A disadvantage of this system was that the quartz window accumulated soot which reduced the transfer of heat.

The second radiant furnace was based on the ISO ignitability cone [10]. The furnace consisted of a truncated pyrex cone coated with a reflective silver-plated layer and contained a resistance coil wrapped around the inside surface (fig. 6). The cone, which was located on the floor of the chamber above the cup furnace, produced unacceptable temperature levels within the chamber.

Because of the poor results from the preliminary experiments with radiant energy furnaces (Note 10), a convective heat furnace similar to the one designed and described by Potts and Lederer [11] was selected. In this system, a quartz beaker with a thermocouple well fits snugly into a stainless steel cup surrounded by ceramic and wrapped with nichrome wire. This cup furnace is surrounded by fire brick and encased in galvanized steel sheet (fig. 3). The quartz beaker in which the sample is degraded is heated to a predetermined temperature which is monitored by an automatic temperature controller.

In the interlaboratory evaluation of the proposed test method, the convective cup furnace was used by all the laboratories. However, different sizes of furnaces and quartz cups were used. They ranged from

Note 10: During the course of these studies, a radiant furnace which fits below the exposure chamber was developed by the Weyerhaeuser Company. Preliminary experiments with this furnace at NBS and two other laboratories indicate that this furnace location may prevent overheating of the chamber. The NBS work on this system will be published as an NBSIR (Packham et al., NBS report in preparation).

79 ml to 954 ml (table 4). Most of the laboratories used a cup of approximately 300 ml; however, NBS also tested a cup furnace with a capacity approximately three times greater (954 ml). Good reproducibility of the Douglas fir toxicological results across laboratories and the repeatability of these results by NBS using two different size furnaces (table 3) indicates that the exact size of the cup furnace is not critical. The larger size, however, is recommended as it can accommodate larger mass loadings of low density materials.

The decision on whether to replace the cup furnace with the radiant furnace or some other combustion module will require additional study. NBS plans to continue research on this issue, but in the present test method recommends the cup furnace because of the greater amount of information and data already obtained on this system from the seven laboratories that participated in the ILE.

3.4 PRESET EXPOSURE TEMPERATURES OR RAMPED TEMPERATURES

In a real fire situation, a material may experience slow or rapid increases in temperature until it ignites in flames, or it may be exposed to temperatures which cause a non-flaming pyrolytic decomposition. Both of these conditions can be approximated in a small-scale test. A third situation, self-propagating smoldering, is not easily simulated under small-scale laboratory conditions. The first scenario can be simulated by a ramped combustion system like that designed by Alarie and Anderson [9] in which a temperature controller is programmed to increase the temperature of the furnace at 20°C per minute and the material bursts into flames at its auto-ignition point. Problems associated with a ramped system are (1) the time necessary to reach the temperature needed to decompose the materials and produce the toxicants, (2) a realistic rate of temperature increase must be chosen, and (3) toxicants from both non-flaming and flaming combustion are combined.

Non-flaming pyrolysis can be approximated by the exposure of a material to a cup furnace heated to a predetermined temperature. The test sample undergoes a very rapid rise of temperature until it

equilibrates with the furnace temperature. In other words, the material experiences a very rapid ramped temperature, but, below the auto-ignition point, stabilizes at the preset temperature, thus permitting the separate investigation of non-flaming pyrolysis. Flaming combustion can be investigated in the same manner, but, in this case, the furnace is fixed at a temperature above that of the auto-ignition temperature of the material. The advantage of this rapid temperature rise is that the combustion products are produced rapidly and the animals are exposed to the highest possible concentration of toxicants for a single loading for the greatest length of time. As the total exposure is relatively short--30 minutes--maximum exposure to the toxicants during that time period becomes important. Thus the decision was made to use preset rather than ramped exposure temperatures.

3.5 ONE TEMPERATURE OR DIFFERENT TEMPERATURES FOR ALL MATERIALS

Good experimental practice prescribes keeping as many variables constant as possible. Therefore, the inclination is to examine all materials at one temperature or perhaps at a set number of constant temperatures. Toxicologists prefer to examine the effects of materials under the potentially most toxic conditions with the assumption that knowledge of the worst case will prevent false negatives, i.e., a material or product that appears safe, even though, under some untested conditions, it may be extremely toxic.

In real fires, a material is subjected to a large number of exposure conditions and the problem is which temperature(s) should be selected for examination in the test method. Examination of all materials at one temperature or even a number of prescribed temperatures does not insure the avoidance of false negatives. It is therefore imperative that the temperature which produces the most toxic combustion products, both in quantity and in intensity, be chosen for evaluation.

Prior research indicated that the higher the temperature the greater the decomposition of the material, with the most decomposition in the

non-flaming mode occurring close to the auto-ignition temperature [11]. Above the auto-ignition temperature, the higher the temperature (under good ventilation conditions), the more complete the combustion, where complete combustion means total conversion to CO_2 and H_2O . Therefore, the greatest quantity of, and most toxic, combustion products in the non-flaming mode are generated just below the auto-ignition temperature of a material. Research performed during the ILE supported this hypothesis. One laboratory examined modacrylic at many temperatures (table 5), and showed that as the temperature approached the auto-ignition point, the combustion products became more toxic as defined by a lower LC_{50} value (for a discussion of LC_{50} values, see section 6.3.3).

Likewise, the greatest quantity of, and most toxic, combustion products in the flaming mode should be generated just above the auto-ignition temperature, since higher temperatures would lead to more complete combustion. However, the effect of furnace temperature is overshadowed by the flame temperature and little difference has been seen in toxic effects.

Therefore, the test method requires the examination of materials 25°C above and below their auto-ignition temperature. If a material is assessed under these temperature conditions and shown not to produce highly or unusually toxic combustion products, it is assumed that other thermal conditions will produce less toxic effects.

3.6 FLAMING AND NON-FLAMING CONDITIONS

3.6.1 Need for Both Flaming and Non-Flaming Conditions. The proposed test method examined by the ILE participants required the evaluation of materials at one flaming temperature-- 25°C above the auto-ignition temperature--and two non-flaming temperatures-- 25°C below the auto-ignition temperature and at 440°C , the temperature at which Douglas fir (the reference material) is evaluated in the non-flaming mode. 440°C was not required if the material's auto-ignition point was within 50°C of 440°C . The 440°C was required initially to satisfy those who believe all materials should be evaluated at the same temperature. The issue is whether all three exposure temperatures are necessary.

Results from the ILE showed that some materials were more toxic in the flaming mode and others were more toxic in the non-flaming mode. All laboratories found acrylonitrile butadiene styrene (ABS), modacrylic (MOD), polystyrene (PSTY), poly(vinyl chloride) (PVC) and rigid polyurethane (RPU) more toxic in the flaming mode. Most laboratories found Douglas fir (DFIR), flexible polyurethane (FPU), polyphensylsulfone (PPS), polytetrafluoroethylene (PTFE), PVC with zinc ferrocyanide (PVCZ), red oak (REDO), and wool more toxic in the non-flaming mode (see section 6.3.3). One disagreement was noted--one laboratory found Douglas fir more toxic in the flaming mode. However, the flaming and non-flaming LC₅₀ (for a 30 minute exposure and 14 day post-exposure period) values were close and fell within the 95% confidence limits of each other.

The above results demonstrate that it is necessary to test each material under both flaming and non-flaming conditions as it will not be clear at the outset which mode produces the more toxic conditions. In no case did the 440°C pyrolysis temperature cause a greater degree of toxicity than the most toxic condition (see section 6.3.2.2 and 6.3.3). As examination of the concentration-response curves at 440°C does not add toxicological information necessary to the assessment of any of the ILE materials and since requirement of this additional temperature significantly increases the expense and time required for the test, NBS decided to make examination at the 440°C temperature optional.

3.6.2 Determination of Auto-Ignition Temperature. The test method requires that the auto-ignition temperature of a given material be determined experimentally before the material is evaluated toxicologically. One problem that became apparent during the determination of the auto-ignition point was the importance of sample size. Initially, a rather small sample was used to find the temperature of auto-ignition. Later, during the actual toxicological testing, larger samples were decomposed and on some occasions, the larger samples underwent an exothermic reaction generating enough heat that the furnace temperature rose above the set

temperature and eventually the material auto-ignited. When this occurred, the auto-ignition and non-flaming temperatures were lowered. Therefore, after determination of the auto-ignition temperature, it is advisable to test a larger sample size (the size determined by the predicted amount that will be decomposed during the tests) at the proposed non-flaming temperature to insure that inadvertent flaming does not occur.

Composite materials pose additional problems with regard to determination of their auto-ignition temperatures which may reflect that component with the lowest ignition point. The non-flaming temperature may then be close to the most toxic condition for that portion of the composite material but may be far enough away from the auto-ignition temperatures of the other components of the composite that those portions decompose less. Therefore, a limitation of this combustion system with regard to composite materials is that the non-flaming toxicological assessment may reflect to a greater degree the component of the composite with the lowest temperature of ignition. The components should not be tested separately as the separate constituents may not exhibit the potential toxicological interaction of the totality, i.e., it is possible that the component parts of the composite material will produce combustion products that act in an additive, synergistic, or antagonistic manner. As was stated earlier, further work on the radiant combustion system may provide a more suitable method for the evaluation of composite structures, such as carpets or layered wall panels.

3.7 SAMPLE PREPARATION

3.7.1 Single or Multiple Pieces. The test method recommends that the sample specimen be tested in one piece if possible (section 2.9.1.1). Materials that were pellets, resins, or powders obviously were tested in that form. NBS tested Douglas fir in one piece and in several pieces. Results showed more CO was generated from two pieces than one piece at the same mass loading of 20 mg/l; however, the toxicity results including time-to-incapacitation were the same (table 6). Three pieces equaling

30 mg/l produced the same amount of CO as one piece of the same weight. Toxicological data was the same in both cases. Four pieces of Douglas fir equal to 40 mg/l produced about the same CO as the 30 mg/l loading and may be indicative of overloading the cup furnace. However, four pieces produced more deaths during exposure and a slightly shorter mean time to incapacitation. These results, although limited, indicated that an increase in the number of pieces from one to four did not produce a significantly different picture either analytically or toxicologically. The decision to use a single piece, if possible, was again based on the perception that materials should be examined in a condition as close as possible to that found in normal use.

3.7.2 Mass Loaded or Mass Consumed. Material of a known mass is placed in the cup furnace. In many cases, a residue remains after the experiment. Should the toxicological findings be based on the amount of material initially placed in the cup furnace or the amount of material that was actually thermally decomposed? Combustion products generated during thermal degradation are diluted with the chamber atmosphere and the amount inhaled by the animals depends upon their respiratory rate and depth of breathing. This test method does not allow the calculation of the actual concentration of combustion products which each animal inhales. The concentration of combustion products in the exposure chamber can be expressed as either the mass of material loaded into the furnace (grams of material divided by the volume of the exposure chamber) or the mass consumed during the exposure (grams of material consumed divided by the volume of the exposure chamber).

When estimating the fire risk associated with the use of a material, the total mass of the material present is usually considered. It seems appropriate to base the test results on the total mass of the sample charged to the furnace. This simplifies the procedure and avoids ambiguities that might result since the weight loss from the sample may depend on furnace temperature. Therefore, the test method specifies that the concentration of material is defined as the amount of material placed into the furnace (mass loaded) divided by the exposure chamber volume.

3.8 PRESSURE-RELIEF PANEL

The generation of combustion products in a static, air-tight system produces an increase in pressure in the exposure chamber and has the potential of causing an explosion. The members of the ILE did not experience any explosions with any of the test materials. However, one member of the ad hoc working group with a different test system did experience an explosion in his laboratory. As a safety precaution, therefore, it is important to build a pressure-relief panel into the exposure chamber. At NBS, this panel was a circle of 8.9 cm cut into the right side of the chamber cover. There are many acceptable ways of covering the opening so as to provide the necessary pressure relief.

3.9 SUMMARY OF COMBUSTION SYSTEM

3.9.1 Decisions. The combustion system in the test method described in section 2 incorporates the results of many decisions based on both experimental evidence and available information. It is not a perfect system and will require future research to resolve some of the still outstanding issues. Briefly, the following decisions were made in arriving at the combustion system used in the current test method:

- (1) the combustion system should be a static system rather than a dynamic one,
- (2) the heating system should be convective rather than radiant,
- (3) exposure temperatures should be preset not ramped,
- (4) the material should dictate the temperature chosen for decomposition,
- (5) both flaming and non-flaming conditions, 25°C above and below auto-ignition temperature, respectively, are required,
- (6) the heat and depletion of oxygen during the exposure should not cause additional stress to the animals (see sections 4.3 and 5.3),
- (7) materials should be examined in a state as close to their normal use as possible, i.e., single pieces, and
- (8) the assessment of materials should be based on the mass loaded into the furnace, not the mass consumed.

3.9.2 Modifications. As a result of the ILE and subsequent tests at NBS, the combustion system described in the test method has been modified from that originally proposed [7, appendix A] in the following ways: (1) a larger cup furnace, approximately 1000 ml instead of 300 ml is now recommended, (2) the examination of materials at 440°C is now optional and (3) the chamber design has been modified to provide for pressure relief.

3.9.3 Future Studies on the Combustion System. Additional studies are needed to resolve the difficulties experienced in handling composite materials. The radiant furnace may be more suitable for evaluating composites, but more research is required on the radiant furnace before a decision can be made as to whether it should replace the cup furnace or be considered an alternate combustion system.

4.0 ANIMAL EXPOSURE SYSTEM

4.1 CRITERIA FOR AN EXPOSURE SYSTEM

Many factors have to be considered in the design of an animal exposure system. A review by MacFarland on respiratory toxicology explored in detail the advantages and disadvantages of various exposure systems [12]. Many decisions made during the development of this test method are based on MacFarland's review. The options and issues examined were (1) whole body exposure of the animals or head-only exposure, (2) static exposure versus dynamic exposure, (3) size of chamber, (4) shape, (5) construction material and (6) exposure duration.

4.2 WHOLE BODY VERSUS HEAD-ONLY EXPOSURE OF THE ANIMALS

Although whole body exposure is the more common approach in most inhalation toxicological studies, it is considered less advantageous in the study of combustion products for the following reasons: (1) considerable heat may be produced during the thermal decomposition of materials and the potential for heat stress of the animal is far greater in whole body exposure than in a head-only exposure mode, (2) smoke obscuration

of the animals contained within the chamber prevents visual observation of biological endpoints such as incapacitation or death, (3) inaccessibility of the animals exposed via whole body prevents monitoring of physiological parameters, such as incapacitation, respiratory rate, EKG, EEG, body temperature, if examination of these functions is desired, (4) blood samples may be taken during the exposure from cannulated animals in the head-only mode or, if not cannulated, animals may be removed rather easily for blood sampling at any time during the exposure with little disturbance to the gaseous atmosphere of the chamber, (5) thermal decomposition of materials produces a large amount of soot and particulates which may be deposited on the fur of the animals exposed via whole body and could be a source of additional toxicants if subsequently ingested during preening.

A disadvantage of the head-only exposure is the necessity of using a restrainer to hold the animals (fig. 7). In addition to the stress that the animals experience being placed into the restrainer, the normal activity of the animals is also restricted. This restriction can affect the animals' respiratory rate and thus the amount of toxic products that the animals inhale, i.e., an animal that is free to exercise will have a greater respiratory rate than an animal prevented from movement.

4.3 STATIC EXPOSURE VERSUS DYNAMIC EXPOSURE

The description of both static and dynamic combustion systems and the reasons for preferring a static system in the NBS toxicity test method are explained in section 3.2 of this report. However, a static system produces some additional constraints that must be considered in the examination of combustion product toxicity in exposed animals. Both the combustion process and the exposed animals consume O_2 and produce CO_2 (the latter is true for the combustion of most materials, although not all). Water vapor is also produced by both combustion and the animals, and thus the relative humidity in the chamber may increase during the static exposure. The amount of CO_2 produced by six animals exposed in a head-only mode for 30 minutes under control static conditions

(no heat, no material decomposition) was 2900 ppm. It was not possible to estimate the CO_2 produced by the combustion of a material by subtracting the concentration of CO_2 produced under control conditions because some toxic atmospheres will change the respiratory rates of the animals.

Thus the rate of CO_2 generation depends upon the material's decomposition products and how these products affect the production of CO_2 by the animals. The same considerations are true for O_2 depletion. These changes in O_2 and CO_2 , which are related to the animals' respiratory rates, cannot be separately analyzed and the total gaseous products have to be analyzed when determining the toxic atmospheres. (Actual results on CO_2 production and O_2 depletion are discussed in section 5.0 of this report). However, by limiting the duration of the exposure to no more than 30-60 minutes and by making the size of the exposure chamber as large as possible (see section 4.4.1), the animal contribution is minimized. For example, 8 grams of Douglas fir in the flaming mode produces about 10 times the amount of CO_2 produced by the 6 rats in 30 minutes.

The distribution of the decomposition products throughout the static system was another factor that was investigated thoroughly. Both analytical measurements on CO , CO_2 , hydrogen chloride (HCl), and hydrogen cyanide (HCN) in various locations of the exposure chamber at different times and a statistical analysis to determine if the order of incapacitation of the animals was related to their location were examined to evaluate the mixing characteristics of the exposure system. These results, which are published in an NBS report [7], demonstrated uniform distribution of the gaseous combustion products.

A static exposure system also retards the dissipation of heat generated by the furnace during the thermal decomposition of materials. As the test method is designed to assess the "chemical" toxicity of combustion products, the temperature of the chamber was monitored to assure that the animals did not have to contend with the additional physiological problem of heat stress. Following a recommendation of the

NAS study [5], the originally proposed test method specified that the chamber temperature should not exceed 35°C for any time period during the 30 minute exposure [7, appendix A]. NBS measured the temperature at the center of the chamber and at animal positions 1, 3, and 6. Both average temperatures over the 30 minute experiment and the maximum temperatures were recorded. Temperatures measured close to the heads of the animals were usually lower than that measured in the center of the exposure chamber. NBS data on the maximum temperatures recorded at the animal positions for each material regardless of mass loaded in the furnace are shown in figure 8. In the flaming mode, these maximum temperatures rose above 35°C for all materials. In the non-flaming mode, the maximum temperature exceeded 35°C for Douglas fir (41°C), modacrylic (38°C), polyphenylsulfone (39°C), polystyrene (36°C), PVC with zinc ferrocyanide (40°C) and wool (36°C). The only material decomposed at 440°C at NBS that caused a chamber temperature greater than 35°C was wool and in this case, the maximum temperature recorded was 36°C.

The maximum chamber temperatures for all the laboratories participating in the ILE are shown in table 7. The variation in chamber temperatures between laboratories is a reflection of the flaming conditions, i.e., the flame temperature, the duration of flaming, the packing of the material into the cup furnace, the available oxygen, and the mass of material loaded into the furnace. This table shows the maximum temperature regardless of the weight of material burned.

The material which produced the greatest increase in chamber temperature was wool decomposed in the flaming mode. NBS found a 41 mg/ℓ concentration caused an initial rise to 109°C during the first minute (fig. 9). Five minutes after initiation of the test, flaming had subsided and the chamber temperature had decreased to 38°C and reached 33°C by 30 minutes. Three animals died during this exposure. However, a 22 mg/ℓ concentration of wool also decomposed in the flaming mode showed a very similar temperature profile reaching 100 °C in one minute and caused no deaths within the exposure (fig. 9). Although more study is needed to determine the synergistic effects of temperature and combustion products,

it appears in this case that the resultant deaths are more likely due to the increased loading and not the increased temperature. For comparison purposes, the chamber temperature profile for Douglas fir decomposed in the flaming mode at a concentration of 52.2 mg/l is also shown in figure 9. In this case, an initial rise to 42°C occurred in 4 minutes and was followed by a gradual decrease to 32°C by the end of the experiment.

Based on the experimental results from NBS and the other laboratories, the average chamber temperature for the 30 minute exposure at the nose position of the animals is not to exceed 40°C. As only the heads and not the whole body of the animals are exposed, it is not believed that these temperatures add a significant thermal stress to the animals. However, more experiments are necessary to determine the additive or synergistic effects of increasing the heat in the chamber in combination with sub-lethal concentrations of toxic combustion products.

4.4 EXPOSURE CHAMBER DESIGN

4.4.1 Size of Chamber. In a real fire situation, the occupants are not expected to remove a significant amount of toxicants or O₂ from the atmosphere nor are they expected to contribute a significant amount of CO₂. In a static exposure system, the size of the chamber must be sufficiently large for the animal contribution to or depletion from the atmosphere to be also insignificant. According to the review by MacFarland, if the animals do not occupy more than 5% of the chamber volume their contribution is not significant [12]. A 300 gram rat occupies approximately 0.3 liters, therefore, to hold 6 rats, the chamber must have a minimum volume of 36 liters. However, the larger the chamber, the less the possibility that the animals will significantly affect the atmospheric concentrations of thermal decomposition products and modify the normal O₂ and CO₂ concentrations. Also a larger chamber reduces the possibility of large increase in temperature. Therefore, a chamber size of approximately 200 liters was proposed for the test method.

4.4.2 Shape of Chamber. Uniform distribution of the combustion products depends upon the shape of the chamber. The NBS toxicity test method exposure chamber is a rectangular box with inside dimensions of 119.4 cm long by 35.6 cm wide by 45.7 cm high (figs. 1 and 2). The cup furnace is located below the left side and six portholes are positioned across the front to hold the animals. This chamber provides good mixing characteristics (see section 4.3). In addition, the chamber allows easy access to the animals and fits in a chemical exhaust hood, a necessary safety feature for testing toxic combustion products.

4.4.3 Construction Material. The chamber is constructed of 1.25 cm polymethylmethacrylate sheet. This material permits good visibility into the chamber and is resistant to the variety of chemical combustion products generated and the heat produced in this series of experiments. The adsorption of hydrogen chloride by the polymethylmethacrylate was tested and presented no problems [7].

Periodic cleaning of the exposure chamber is required to prevent cross contamination of toxicants and to reduce carbonaceous material from acting as a scavenger for various reactive chemical species. The chamber was always cleaned between experiments on different materials as well as between different temperature modes. Ethanol applied with disposable towels proved to be the best method for removing the various decomposition products that had deposited on the inside surface of the chamber.

The only means of access to the NBS exposure chamber is to remove its top. This may not be the best design as it makes the chamber difficult to clean. A chamber designed with several removable sections would facilitate cleaning. However, more removable sections increases the possibility of leakage of the gaseous products of the chamber's atmosphere.

The quartz sample beaker which fits into the furnace was washed and the remaining products removed by a propane torch after each experiment. It is advantageous to have several quartz beakers on hand.

4.5 EXPOSURE DURATION

In most experiments, the animals are exposed to the combustion atmosphere for 30 minutes. This time was chosen as representative of a reasonable time for an occupant to escape a burning building or to be rescued. In addition, 30-60 minutes is about the maximum time that the animals could remain in a static exposure system without significantly influencing the atmosphere (depletion of O₂, increase of CO₂) as described in section 4.3 of this report.

Additional optional exposures of only 10 minutes in length are also described. These shorter experiments in which the animals are exposed to relatively high concentrations (30 mg/l) were designed to distinguish materials that rapidly produce effective concentrations of toxicants. After both the 10 minute tests and the 30 minute tests, the animals are kept for a 14 day post-exposure observation period. The rationale for these tests will be further explained in section 6.4.

At NBS, the exposure began with the dropping of the sample into the preheated cup furnace and closing the door of the chamber. The exposure ended with very rapid exhausting of the chamber atmosphere.

4.6 SUMMARY OF ANIMAL EXPOSURE SYSTEM

The following decisions were made in arriving at the animal exposure system used in the current test method:

- (1) the animals should be exposed head only, not whole body,
- (2) a static animal exposure system rather than a dynamic exposure system should be used,
- * (3) the average chamber temperature for the 30 minute exposure at the nose position of the animals should not exceed 40°C,

* New procedures or procedures that have been modified from those proposed in the original test method [7, Appendix A].

- (4) the exposure chamber should be a polymethylmethacrylate rectangular box of approximately 200 liters,
- (5) the animals are exposed for 30 minutes to the combustion atmosphere in most experiments, and
- * (6) in some cases, an optional animal exposure of only 10 minutes to a concentration of 30 mg/l may be used.

5.0 CHEMICAL MEASUREMENTS

5.1 NEED

Thermal degradation can produce hundreds of gaseous compounds, including for example, carbon monoxide, carbon dioxide, oxides of nitrogen and sulfur, hydrogen cyanide, hydrogen chloride, simple hydrocarbons, oxygenated organic products (aldehydes, ketones and acids) and nitrogen-containing organic products (amines and nitriles). A detailed analysis of these products requires sophisticated analytical equipment, e.g., a gas chromatograph-mass spectrometer (GC-MS) in conjunction with an on-line data reduction system. Such an analytical scheme is costly and impractical for a routine test method. Therefore, the test method is limited to the identification and quantification of selected gaseous products of recognized toxicological importance.

According to a review of toxicological and fire accident data [3], the three most important combustion products are CO, CO₂, and HCN. CO and CO₂ are produced during most combustion processes, since all organic compounds contain carbon. Materials that contain nitrogen are potential producers of HCN.

CO is an important toxicant because of its ability to combine with hemoglobin and displace oxygen in the blood. The main physiological effect of CO₂ at concentrations generated in this study is to increase

* New procedures or procedures that have been modified from those proposed in the original test method [7, Appendix A].

respiration of the animals. Furthermore, production of CO_2 is an indication of completeness of the combustion process and the relationship between CO_2/CO ratios and O_2 concentration can be used to illustrate changes in the combustion process, if desired. HCN has a relatively high toxicity as it acts by inhibiting cellular respiration. Even though the increased use of polymeric materials containing nitrogen has focused attention on the potential involvement of HCN in fire environments, measurement of HCN during the proposed test method is optional. This is mainly because of the lack of a suitable automated technique for measuring HCN in fire atmospheres and in biological samples. Three laboratories in the ILE measured chamber concentrations of HCN when nitrogen-containing materials were degraded. Recently, a guide for measuring various combustion products has been published which can serve as a useful reference for the selection of appropriate measurement techniques for gaseous toxicants, including inorganic halides, HCN, oxides of sulfur and nitrogen, and aldehydes [13].

5.2 INSTRUMENTATION.

5.2.1 Sampling System at NBS. The system used by NBS for sampling combustion products from the exposure chamber was designed to obtain a representative sample, maximize recovery, and to avoid introduction of errors due to sampling techniques.

Figure 10 is a schematic of the continuous sampling system chosen for the determination of the time dependence of CO , CO_2 , and O_2 concentrations. At NBS, the gaseous products are pumped at a rate of 2ℓ/min through the main sampling line. Approximately 0.5ℓ/min pass through each instrument and are returned to the chamber to avoid alteration of the combustion product concentration in the exposure chamber. Any excess gaseous products which do not pass through the instruments are returned to the box via the pressure relief valve (PRV) in the pump (fig. 10). Sample transfer flow rates were measured using rotameters.

To collect a representative sample, a sampling probe is introduced through the top, between the third and fourth animal position, about 15 cm into the chamber. Pretreatment of the gas sample is done by a glass wool filter and an ice trap for the removal of particulates and water vapor to avoid their interference with analytical measurements. Invariably, the removal of particulate matter was found to be necessary as the smoke particles caused malfunctioning of the sampling pump and deposits in the analytical apparatus.

The sample transfer lines are constructed of non-permeable polyethylene tubing. PTFE tubing is used in some interconnections of instruments. These materials are usable with essentially all types of combustion products. A small stainless steel diaphragm type compressor pump is used.

To assure the retention of sample integrity by minimizing adsorption and condensation on surfaces, it is usually recommended that filters and transfer lines be heated [13]. However, since an ice trap is inserted into the sampling system to remove moisture, heating of sample lines is not considered necessary. During a 30 minute exposure period a total of 60 ℓ (about one-third of the total volume) passes through the sampling system at NBS. Some condensation of combustion products occurs in the ice trap and cannot be avoided (see Note 9, page 24). Lowering of the trap temperature, e.g., with dry ice, was found to decrease the overall toxicity of the combustion atmosphere, presumably by more effective condensation of combustion products, and is therefore not recommended.

On occasion, the investigator may wish to measure hydrogen cyanide concentrations in the chamber atmosphere. For determination of time dependence of HCN concentration in NBS tests, a batch sampling technique is used for immediate analysis by gas chromatography. The combustion atmosphere is sampled with a gas-tight syringe through a septum in the front wall of the chamber at the level of animal noses. The sampling frequency depends on the retention time of HCN and the chromatographic profile of the nitrogen-containing products which are determined for each material tested. Sampling times are selected so that the eluting

HCN peak does not encounter any interference. The volume of gases removed by the syringe sampling technique (100 μl each time) is insignificant when compared to the total volume.

5.2.2 Carbon Monoxide and Carbon Dioxide. Commercial nondispersive infrared analyzers based on the Luft cell principle are employed for continuous monitoring of CO and CO₂ in the combustion mixture. The analyzers are specific for single gases and CO₂ concentrations up to 200,000 ppm do not interfere with the CO measurements. In most cases, the CO concentration is low in comparison to CO₂ and its interference with CO₂ measurements need not be considered. The cold trap minimizes any likely interference by water vapor.

To cover the concentration ranges encountered in the exposure over the loading ranges studied for all the materials, it is necessary to outfit the analyzers with cells of several lengths. During the test method development, the following ranges were needed:

CO	CO ₂
0-1000 ppm	0-5000 ppm
0-5000	0-25,000
0-10,000	0-50,000
0-50,000	0-200,000

To assure the accuracy of measurements, calibration of the infrared instrumentation is carried out before each experiment using appropriate certified gas mixtures (CO and CO₂ in nitrogen) available commercially. Since the exhaust from the analyzers is normally returned to the exposure chamber, it is necessary that the line be disconnected from the chamber during calibration, e.g., by using a 3-way valve, to avoid buildup of calibration gases in the exposure chamber.

5.2.3 Oxygen. The continuous monitoring of O₂ in the exposure chamber was carried out using an oxygen cell in which O₂ diffused through a membrane into KCl electrolyte where an electrochemical reaction between

two electrodes took place. The strength of the current generated was directly related to the amount of O_2 introduced. The cell was calibrated with ambient air assuming 20.9% O_2 content.

5.2.4 Hydrogen Cyanide. The analysis of HCN in the combustion atmosphere was determined by a gas chromatographic method utilizing an alkali flame (or thermionic) detector in conjunction with Porapak Q column at $110^\circ C$. The details of development of the technique have been described by Paabo *et al.* [14]. Under the experimental conditions the retention time for HCN was about 2 minutes, allowing HCN samples to be taken every 2-5 minutes. The thermionic detector was tuned with H_2 and air (flow rates of 3 and 100 ml/min, respectively), so that no interference by low molecular weight hydrocarbon compounds would be observed. Calibration of the gas chromatographic system was performed with certified reference gas of HCN in nitrogen, available commercially. The concentration of HCN gas mixtures in new tanks was verified by titration with standard $AgNO_3$ solutions. Since the HCN reference gas is somewhat unstable, the concentration of HCN gas mixtures in old tanks was checked periodically by titration and gas chromatographic techniques. All cylinders of HCN should be used and stored in a chemical hood as a safety precaution.

5.3 NBS RESULTS

The following information is presented to illustrate how analytical measurements can provide additional information on the nature of the toxic effect. The test method requires that CO , CO_2 , and O_2 be measured during animal exposures. During the development of the test method, analyses were carried out for all materials except for polytetrafluoroethylene (because of the possibility of fluorides damaging the instrumentation). For the six nitrogen-containing materials, ABS, flexible polyurethane, modacrylic, poly(vinyl chloride) with zinc ferrocyanide, rigid polyurethane, and wool, HCN measurements also were made during animal exposures.

The data obtained during animal exposures as well as data obtained during analytical runs are included in the following summary. As noted in section 3.3, NBS used two furnaces of different sizes designated as furnace a (small - 300 ml cup) and furnace b (large - 954 ml cup). The auto-ignition temperatures found by NBS are listed in table 25.

CO, CO₂, and HCN are reported as the mean and standard deviation of the ratios of the concentrations (ppm) of the gas (averaged over the 30 minute exposure) to the mass loading/chamber volume (mg/l) for each test of a material. These results are shown in tables 8, 9, and 10, respectively. Data for O₂ are reported as minimum average percentages (the experiment that produced the lowest average oxygen concentration) in table 11. The average concentrations of a species for an experiment was obtained by integrating the area under the instrument response curve and dividing by the duration of the experiment, 30 minutes. Graphic representations and least squares linear regression analyses of the generation of CO and HCN versus mass loading in the non-flaming and flaming modes are shown in figures 11, 12, 13, and 14.

In the case of Douglas fir, the production of CO was found not to be linearly proportional to mass loading over the total range of concentrations studied. The upper limit of linearity was 30 mg/l in the non-flaming mode and 50 mg/l in the flaming mode. This apparent overloading of the cup is illustrated graphically in figures 15 and 16. The CO concentrations for Douglas fir above 30 mg/l (non-flaming) and 50 mg/l (flaming) were not included in the slope calculations. No overloading of the cup was observed for the other materials examined in this study.

The CO₂ concentrations recorded by the infrared analyzer include the CO₂ produced by material degradation and animal respiration, as well as the CO₂ content in the ambient air. In analytical runs without animals, CO₂ generation was always found to be lower than that found in the animal experiments; only the latter are shown in table 9.

According to the test method proposed at the start of the ILE, the O_2 level should not fall below 18% during the exposure. Although both the average and the minimum percent O_2 for the 30 minute exposure period were recorded, only the average reading was used to meet the 18% qualification. The average O_2 concentration remained above 18% for all materials in the non-flaming mode and at 440°C. In the flaming mode, the average O_2 concentration fell below 18% for six materials. In five out of six experiments in which O_2 deficiency was observed, the average O_2 level remained above 16%. In the exception, the lowest average O_2 level recorded was 14.2%. Recent studies reported by Matijak-Schaper and Alarie [15] show that their animals (mice) were essentially unaffected by a reduction of the oxygen level from 20.9% (normal atmospheric) to 10%. Only slight decreases in the average respiratory rate were observed at 9% oxygen. Based on this information, the criterion for the minimum average O_2 level in the toxicity test method as described in section 2 was changed to 16%. The test method requires that O_2 be introduced into the exposure box whenever the O_2 concentration decreases below 16% during the 30 minute experiment.

Of the six nitrogen-containing ILE materials examined, modacrylic produced the largest amount of HCN in both the flaming and the non-flaming modes. Flexible polyurethane generated the lowest amount of HCN. Three materials, rigid polyurethane, PVC with zinc ferrocyanide, and wool, generated significantly more HCN in the non-flaming mode than in the flaming mode. Time-dependence curves for CO and HCN (figs. 17 and 18) illustrate the rate of release of the two gases.

5.4 SUMMARY OF CHEMICAL MEASUREMENTS

The following decisions were made in arriving at the current chemical analysis system:

- (1) measurements of CO, CO_2 , and O_2 should be continuous or every two minutes,

- * (2) the average O₂ level during the 30 minute exposure should not fall below 16%, and
- (3) measurement of HCN is optional.

6.0 ANIMAL MEASUREMENTS

6.1 NEED FOR ANIMALS

In addition to atmospheric chemical measurements, animal exposures are necessary to assess the toxicity of combustion products. Although sampling and analytical methods have been developed for many of the known toxicants produced in a combustion atmosphere, chemical analysis of all the suspected toxicants would be a formidable task. Even if such a task could be routinely accomplished, the possibility of missing an unknown or unsuspected toxicant always exists. In addition, the toxicological properties of many of the combustion products are not known and knowledge of possible interactions is almost non-existent. An animal, on the other hand, will respond to all the individual toxicants present and also will respond to the additive, synergistic, or antagonistic metabolic interactions that the various combinations of chemicals can produce within the body. At the present time, the assessment of the toxicological effects of material decomposition products does not distinguish between the effects of individual toxicants and the combination of effects that may occur when a multitude of toxicants is produced. However, an animal will integrate the combination of effects and react with a visible or measurable biological response. First, the animal's reaction demonstrates that a material produces toxic products, then atmospheric chemical analysis is used to identify the toxicants and to determine if they are present in sufficient quantities to account for the observed toxicity.

* New procedures or procedures that have been modified from those proposed in the original test method [7, Appendix A].

6.2 TEST ANIMALS

6.2.1 Animal Species. Experiments may be performed using one or more animal species. The use of a single inbred animal species is more likely to produce better repeatability of quantitative results between experiments and greater reproducibility between laboratories. The observation of similar experimental effects in different animal species increases the probability that the same effect will occur in humans as well. The decision to use one inbred animal species rather than multiple species was based primarily on economics. Testing materials at three different temperatures (flaming, non-flaming, and 440°C) and examining both incapacitation and lethality would be costly enough without compounding the expense by repeating all the experiments with more than one animal species.

The rat was chosen as the experimental animal because (1) a significant amount of the research in toxicology in general, and combustion toxicology in particular, has used rodents, either rats or mice; (2) the available literature constituted a considerable source of valuable information; (3) the greater size and blood volume of the rat (compared to the mouse) permitted arterial cannulation and blood samples for quantitative analysis to be taken during and following the exposures; and (4) other physiological parameters could be more easily monitored in the larger animal. The choice of rats does not imply that a correlation exists between the effects in rats and humans.

6.2.2 Animal Sex, Weight, Age, and Strain. The use of adult male rats weighing between 225 grams and 325 grams and 3-4 months of age is designated in the test method (section 2). The decision to use males rather than females was based on the desire to reduce all sources of possible variability, as for example, the female estrus cycle. The elimination of the female gender, however, introduces the possibility that a toxic response peculiar to females may be overlooked.

The size of the rat was important for two reasons. First, the animals should be in a growing stage as a weight profile can be used to determine experimental effects on post-exposure health. Weight loss is obvious, but subtle changes in rate of weight gain would only be noticeable in animals whose controls are still gaining weight daily. Second, excessively small or excessively large animals presented problems of restrainer fit. As a variety of strains are permitted by the test method, the age of the rats (3-4 months) as well as the weight is specified.

Investigators may choose the rat strain. The test method recommends Fischer 344 rats as they are easy to handle and grow at a slower rate than other strains. A slower rate of growth permits a longer period of time during which the animals can be kept before they outgrow the capacity of the restrainer. Although Fischer 344, Sprague-Dawley, and Long-Evans rats were used by different laboratories in the interlaboratory evaluation of the test method, the differences in strains did not affect the reproducibility of results (NBS report of ILE, in preparation). It is advisable, however, to consult the Catalogue of NIH Rodents [16] to insure that the rat strain chosen does not have a particular susceptibility to disease or potential lung problem which would cause that strain to be unsuitable for acute inhalation toxicity studies.

6.2.3 Animal Maintenance and Care. Animal care should be performed according to the procedures in the "Guide for the Care and Use of Laboratory Animals" [17]. In addition, it is recommended that the animals should be received and kept at least 10 days prior to experimentation to allow acclimation to the laboratory conditions and to insure the health of the animals. Normal growth, as determined by daily weighing, is a good indication of proper care and health. Randomly selected animals from each batch should be designated as controls, weighed daily, and kept as long as any of the experimental animals of the same batch. Animals should be housed individually in a temperature ($\sim 22^{\circ}\text{C}$) and humidity ($\sim 50\%$) controlled room. Twelve hours of lighting per day should be provided, preferably by an automatic timer. Food and water should be supplied ad libitum. The six experimental animals for each

experiment should be chosen randomly from the same batch. If blood samples are desired during the exposure, cannulation of two of the six experimental animals should be performed 24 hours prior to the test [18].

On the day of the experiment, the animals should be weighed and then placed into their restrainers, two of which are modified to provide access to the cannulae. The animals should not be placed in the exposure chamber until immediately before the start of the test, since once the animals are positioned in the chamber, CO₂ due to respiration may increase in the chamber. Any increase in CO₂ prior to the test can be prevented by adequate aeration of the chamber. Blood sampling, and the biological endpoints of incapacitation and lethality will be covered in sections 7 and 6.3, respectively. All animals not used for blood sampling which survive the exposure are kept and weighed daily for a 14 day post-exposure observation period. Animals which provide blood samples are sacrificed following the exposure.

6.3 BIOLOGICAL ENDPOINTS

Toxicity tests measure the effects of a compound upon a living organism. These effects occur at the molecular, cellular, organ, and/or whole body level and depend upon the concentration of the compound, the method of exposure, and the exposure duration. Although mechanism of action is of interest, such information is not necessary for a first level screening test designed to assess the relative toxicity of the combustion products from various materials. Living organisms are necessary to absorb the toxicant, react in some fashion either to the toxicant directly or to the secondary metabolic products of the toxicant, and exhibit a biochemically determinable, measurable, or visible endpoint. This endpoint, which has to be quantitative, repeatable, and reproducible, is then used to compare the relative toxicity of one material to another or to a reference material.

The NBS toxicity test method employs the rat as the living organism for the reasons detailed in section 6.2.1. The biological endpoints

monitored during the development of this test method and its interlaboratory evaluation were incapacitation, lethality during the exposure, and lethality during the exposure plus a 14 day post-exposure observation period. In addition, changes in blood carboxyhemoglobin content were monitored to assess whether the primary or sole toxic combustion product was carbon monoxide (see section 7.0). Questions of the necessity of all these endpoints and which endpoint provides sufficient information to assess the relative toxicity of materials were experimentally investigated by NBS and the other participants during the development of the test procedure. Another issue that received much attention questioned whether setting the exposure time and measuring the effect of varying concentrations was preferred experimentally over setting a concentration and measuring the time-to-effect. The results of an extensive evaluation of these issues were (1) lethality within the 30 minute exposure time plus the 14 day post-exposure observation period provided more information with which to assess the relative toxicity of the combustion products of materials than either incapacitation or lethality within the exposure period only, and (2) data across laboratories were more reproducible if the exposure time was set and the weight of material varied than if time-to-effect was the endpoint. In addition, time-to-incapacitation did not include the post-exposure effects and thereby failed to provide this additional, necessary information. The following sections provide the experimental justification for these decisions.

6.3.1 Incapacitation Models. One recommendation of the Committee on Fire Toxicology working under the auspices of the National Research Council [5] stated that animal incapacitation be considered the most important experimental endpoint as it is directly related to escape capability. They also recommended that the animals be observed for two weeks following exposure and that the relative toxicity of materials be determined by comparison of endpoints with those of reference materials. They emphasized that simple reproducible techniques should be developed for assessing incapacitation.

A number of animal incapacitation models, none of which are simple, have been developed to study the toxicity of combustion products. Examples of behavioral models are: (1) the rotating activity wheel, (2) the lever actuation conditioned avoidance response developed by Annau, (3) the rotarod, (4) the greased pole, (5) Alarie's respiratory rate model, and (6) hind-leg flexion conditioned avoidance response.

The rotating activity wheel, a round mesh cage which is mechanically rotated, forces the animal to walk or run continuously depending on the speed of rotation [19]. Experiments at NBS with this model indicated many difficulties. The main disadvantage stems from the location of the system within the exposure chamber where: (1) smoke will obscure observation of the animals, (2) the animals are more likely to experience heat stress due to whole body exposure, (3) blood samples or other physiological monitoring during the exposure are extremely difficult, or impossible to obtain, and (4) the toxicants will be deposited on the fur of the animals with the possibility of subsequent ingestion by the animals while grooming.

Annau developed a conditioned response behavioral model in which the animals learned to press a lever to avoid a shock [20]. As the whole body of the animal was also exposed in this system, many of the problems of the rotating activity wheel were also experienced with this method. Visual observation of the animal was not necessary as a computer registered all shocks received by the animals, an indication of failure to perform. An additional disadvantage of this system is the long period of time necessary for training.

In another behavioral model, the rotarod technique, an animal learns to stay on a rotating rod in order to avoid falling onto an electric grid and receiving a shock [21]. Training is accomplished in one hour per day for two days prior to the experiments. Again, whole body exposure is the main disadvantage of this model.

The "greased pole" model, developed by SRI International, involves teaching rats to prevent an electrical shock by responding to auditory and visual stimuli and seeking refuge on a pole suspended from the ceiling of the cage [22]. The shocking mechanism is turned off by the animal's weight on the pole which is greased to prevent the rat from staying on it. This system measures both avoidance (the animal responds to the sensory indicators and prevents the occurrence of the shock) and escape (the animal responds to the shock by jumping on the pole) mechanisms. The disadvantages are those related to whole body exposure as described above for the rotating activity wheel and the long training period (four days of intensive training is required).

Alarie has developed a biological endpoint based on changes in body movements (escape movements) and change in respiratory rate due to inhalation of irritants present in smoke [9]. In this model, only the heads of the animals (mice) are exposed. Since both the escape movements and respiratory measurements are measured by computerized outputs of pressure changes in the plethysmograph where each animal is placed, the animals are inaccessible for blood measurements during the exposures. Furthermore, in a recent report [15], Matijak-Schaper and Alarie concluded that measurement of escape movement was not significantly more sensitive than measurement of asphyxiation or death in detecting the effect of asphyxiants such as CO or HCN.

The behavioral model examined most extensively by NBS and the participants in the interlaboratory evaluation is the hind-leg flexion conditioned avoidance response developed by Packham [23]. In this model, one of the rat's hind feet is attached to an electrode such that when the foot touches a metal plate located below the restrainer, the animal receives a small electrical shock. The animals learn quickly (approximately 15 minutes) to avoid the shock by keeping the instrumented limb raised above the metal plate. During the experiments, the animals are considered incapacitated when they no longer respond to the shock. This model was chosen by NBS as it exposes the rats in a head-only position which permits blood and other physiological parameters to be monitored

as well as incapacitation. Heat stress is minimized since the whole body is not exposed. A disadvantage of this behavioral system over whole body exposure is the stress the animals undergo when being placed in the necessary restrainers. A criticism of this model is that no conscious effort is needed by the animal, i.e., the response to the shock is merely a reflex action and the animal will be close to death before this response will fail.

Since these models have not been examined under the same conditions with the same materials, it is not possible to decide on the basis of experimental evidence which is the best model to assess the incapacitating effect of materials. As each method has both advantages and disadvantages, the choice of one over the other appears to be a matter of personal preference. It is clear, however, that no single animal incapacitation or behavioral model will be equally sensitive or responsive to the broad spectrum of compounds produced from polymer thermal degradation. With the exception of the respiratory model of Alarie which measures sensory and pulmonary irritants, all of the above models monitor the loss of neuro-muscular functions. Ideally, the behavioral model should measure the overall ability of an animal to escape and should be a significantly more sensitive indication of toxic combustion products than a lethality measurement.

6.3.2 Measurement of Incapacitation by the Hind-Leg Flexion Behavior Model.

6.3.2.1 Time-to-Incapacitation. In the experiments performed at NBS and the other laboratories in the interlaboratory evaluation of the test procedure, time-to-incapacitation was measured for each animal and a mean time with a standard deviation was calculated for the six animals exposed in each experiment. In early experiments at NBS, the mass loading was kept constant and the times-to-incapacitation of all six animals were measured. In this manner, the mean time-to-incapacitation could be compared for the same mass loading of materials. This procedure worked better for some materials than for others. Those materials whose

combustion products caused post-exposure effects rather than within-exposure effects produced extremely variable results when examined by this method. Poly(vinyl chloride) is an example of such a material. Upon thermal decomposition, PVC produces HCl, a potent toxicant and highly irritating acid gas. The animals start reacting immediately by touching the plate repeatedly and soon appear incapacitated (failure to respond to the shock). If they appear incapacitated, the shocking mechanism is turned off. However, when the animals are removed from the chamber at the end of the 30 minute test, it is obvious that they are still fully capable of moving and reacting. The irritating effects of the combustion products from this material are so intense that the animals fail to react to the shock. If, on the other hand, the shocking mechanism is not turned off when the animals appear incapacitated, they soon start reacting again. This seemingly incapacitated state will recur repeatedly during the exposure. Within the same experiment the actual time of incapacitation varied widely (table 12) and some animals died before others were incapacitated. Other materials, mainly those which produced within exposure effects, showed good repeatable results with the method.

Time-to-incapacitation can be examined in another manner. The exposure duration can be set (for example, at 30 minutes) and the mean and standard deviation of the time-to-incapacitation for the exposed animals can be calculated for different mass loadings of material. The lower the mass loading, the more time needed to incapacitate the animals. These points will be represented by a function which asymptotically approaches a threshold time-to-incapacitation on one axis and a concentration of material needed to produce incapacitation in the specified time limit on the other axis (fig. 19)[24]. It is important to note, however, that built into this threshold time and concentration is the time necessary for the decomposition of the material. Wood, for example, takes longer to decompose than some thermoplastics.

In section 4.3 of this report, the reasons for not having the exposure exceed 30 minutes are noted. With the exposure time set at 30 minutes, however, some concentrations of combustion products cause

incapacitation in less than the total six animals. Therefore, the mean and standard deviation of the time-to-incapacitation of all six animals can not be calculated. In these cases, where two to five animals are incapacitated, a statistical treatment called the Best Linear Unbiased Estimate of Censored Data (BLUE) is used to estimate the mean and standard deviation [25]. Even this statistical treatment of the data, however, can not provide many data points at the lower mass loadings where the mean time-to-incapacitation is longer than 30 minutes.

The mean times-to-incapacitation that were obtained experimentally or via the BLUE estimate for each material in each mode were used to best fit a hyperbolic curve ($Y = Q + R/X$). Six examples of these hyperbolic curves for Douglas fir in the non-flaming mode are shown in figure 20. The hyperbolic equations are shown on each graph. Similar time-concentration hyperbolas were generated for all the materials in both flaming and non-flaming modes from the NBS data and that supplied to NBS by the other laboratories. The Q and R coefficients calculated for each material in each mode from all the laboratories are presented in table 13. Visual inspection and comparison of the coefficients indicate the differences between the curves. The problems that arise with the use of the hyperbolic curves for the analysis of relative toxicity of the combustion products of materials are: (1) differences in time to incapacitation of 5-10 minutes are equivalent to 16-30% of the total 30 minute time frame, i.e., experimental scatter is inevitable, (2) the 30 minute exposure time limits the number of data points at lower mass loadings, and (3) comparison of the various curves to determine relative toxicity of materials is difficult.

6.3.2.2 EC_{50} . Another means of analyzing the incapacitation data was to determine the EC_{50} , the concentration (mass loading of material divided by the exposure chamber volume) which was necessary to incapacitate 50% of the rats in the 30 minute exposure. The percent of animals incapacitated at each mass loading tested was plotted on logarithmic probability paper to obtain a concentration-response curve. The slopes of these curves, their 95% confidence limits, the EC_{50} 's, and

their 95% confidence limits were statistically determined by the method of Litchfield and Wilcoxon [26]. For the statistical analysis of these curves, three data points were needed between 0% effect and 100% effect, e.g., 17% (1/6 incapacitated), 50% (3/6), 83% (5/6). In some cases, however, a small change in concentration (e.g., 0.5 mg/l) would cause the number of animals incapacitated to change from 0% to 100%. In these cases, the EC_{50} was estimated from the linear plot of the data (fig. 21). Whenever a value was estimated, the approximate sign (\sim) is placed before that value and the extremes used to estimate that value are placed in brackets. Table 14 shows the EC_{50} values (those statistically determined and those estimated) with their 95% confidence limits in parenthesis. The slopes of the concentration-response curves and their 95% confidence limits are shown in table 15.

The slope of the curves are important for the toxicological analysis of the materials. The EC_{50} of two materials may be the same but one slope may be much steeper than the other (fig. 22). The steep slope indicates that a threshold concentration is needed before any effect occurs and that a small increase in concentration will cause all the animals to react. A less steep slope indicates that the measurable biological response will occur over a wider concentration range.

6.3.3 Lethality. The most common biological endpoint in toxicology is the LC_{50} --the concentration which is necessary to cause 50% of the animal population to die in a set period of time. The proposed test method required that lethality be monitored during the 30 minute exposure and a 14 day post-exposure observation period. The animals were to be exposed to different concentrations in order to generate a concentration-response curve similar to that described for the EC_{50} in section 6.3.2.2 (fig. 21).

The data on each material in each mode (flaming and non-flaming) were used to calculate an LC_{50} for the 30 minute exposure and an LC_{50} for the 30 minute exposure plus a 14 day post-exposure observation period using the statistical method of Litchfield and Wilcoxon [26].

Tables 16 and 17 show the LC_{50} values and their 95% confidence limits for the 30 minute data and the 30 minute plus 14 day data, respectively. Tables 18 and 19 show the slopes and 95% confidence limits of the concentration-response curves for the LC_{50} for the 30 minute exposure and those for the LC_{50} for 30 minutes and 14 days, respectively. Those LC_{50} values that could not be determined statistically were estimated in the same manner as described for the EC_{50} in section 6.3.2.2, where the importance of the slope information is also discussed.

Some of the advantages of using lethality as an endpoint are: (1) LC_{50} calculations have been traditionally used in toxicology, (2) the statistics for handling the data are well documented, (3) the determination of the endpoint is simple, (4) the results are repeatable within a laboratory and reproducible across laboratories, (5) the concentrations tested are only limited by furnace size and the explosion limit, and (6) due to the wider range of concentrations which may be tested, relative LC_{50} values of materials can be compared over several orders of magnitude.

6.3.4 Comparison of Incapacitation and Lethality Results. The purpose of the toxicity test method and the interlaboratory evaluation has been to develop a test which can be used to assess the toxicity of combustion products. In the interlaboratory evaluation, both incapacitation and lethality data were collected, analyzed, and compared to determine whether both types of measurements were necessary. Table 20 and figures 23 and 24 compare the NBS results on the EC_{50} , LC_{50} (30 minutes) and LC_{50} (30 minutes + 14 day) data in the flaming and non-flaming modes and at 440°C. An examination of that table and those figures show that most of the materials produced combustion products with toxicity similar to that of Douglas fir. The perceived toxicities of the combustion products of most materials did not change their relative positions regardless of whether incapacitation (EC_{50}), the within exposure lethality (LC_{50} , 30 minutes) or the lethality for within exposure plus the 14 day post-exposure period (LC_{50} , 30 minutes + 14 day) data were used for the comparison. However, the combustion products of ABS (flaming mode), FPU (non-flaming mode), PTFE (flaming and non-flaming modes), and PVC

(non-flaming mode) caused significant post-exposure mortality. The within-exposure incapacitation and lethality determinations result in a less sensitive measurement of toxicity, i.e., the animals were not incapacitated or killed during the 30 minute exposure period until the concentration was considerably larger than the concentration which produced lethality during the post-exposure period. Therefore, the LC₅₀ results for the 30 minute exposure plus the 14 day post-exposure period, which provided information on the delayed effects, supplied a more complete picture of the toxic effects of the combustion products of a material than the within-exposure endpoints.

This conclusion was also reached in a comparison of EC₅₀, LC₅₀ (30 minutes) and LC₅₀ (30 minutes + 14 day) data from all the participating laboratories. To make this cross laboratory comparison, the value from each laboratory for each material in each mode was normalized to its Douglas fir data in that same mode. Then the mean of the normalized values from all the laboratories for each mode was determined. The results from NBS, which had two sets of Douglas fir data, were kept internally consistent, i.e., the results of a material which had been thermally decomposed in furnace "a" were normalized with the Douglas fir data from furnace "a". In those few cases where data were used from both NBS furnaces to calculate the EC₅₀ or LC₅₀ values, an average value of the Douglas fir results from both furnaces was used for normalization. All the normalized values for the LC₅₀ (30 minutes + 14 day) data were then ordered from the least toxic to the most toxic. Tables 21, 22, and 23 show this ordering of materials for the flaming, non-flaming, and 440°C modes, respectively. The average normalized values for the LC₅₀ (30 minutes) and EC₅₀ are all listed on these tables for comparison purposes. The listing of materials in this manner was not to rank order the materials but rather to compare methods of analysis (Note 11).

Note 11: It is important to note that the results shown in tables 21, 22, and 23 pertain to the particular samples tested during this study. The materials used were selected to represent a wide range of properties. No attempt was made to provide statistically valid samples of a given material. Therefore, the results should not be used to judge any particular class of material.

These results show that the various means of determining toxicity [LC_{50} (30 minutes + 14 days), LC_{50} (30 minutes), and EC_{50}] provide the same relative ranking of materials (especially if the standard deviation of those normalized values is considered) with the exception of PVC. When compared with Douglas fir, PVC is less toxic if the EC_{50} in the non-flaming and 440°C modes are considered; it is more toxic if the LC_{50} (30 minutes + 14 day) data are considered. In other words, since most animals die during the post-exposure period, PVC appears less toxic when only the within exposure results are examined.

The above results show that, in most cases, the LC_{50} (30 minutes), and EC_{50} provide the same degree of sensitivity in distinguishing the toxicity of combustion products. However, the LC_{50} values that include the 30 minute exposure plus the 14 day post-exposure observation period increase the sensitivity of the test to detect those materials that produce toxic products which are primarily respiratory tract irritants and cause post-exposure deaths.

In summary, two different methods of comparing the incapacitation and lethality experimental results have been examined. In both cases, the lethality results which include the post-exposure effects provide more information with which to compare and assess the toxicity of the combustion products of materials than the incapacitation data. It was on the basis of this experimental evidence that the decision was made to eliminate incapacitation from the test method and to require the determination of the LC_{50} based on the 30 minute exposure plus 14 day post-exposure observation period.

6.4 ASSESSMENT OF MATERIALS THAT RELEASE TOXICANTS RAPIDLY

The percent lethality due to a toxicant is dependent on both the exposure time and concentration. The relationship between these factors may be represented by a three dimensional concentration-time-lethality figure (fig. 25)[24]. The percent lethality is represented on the

vertical axis (z), concentration and time are represented on the horizontal axes, x and y. The surface can be determined by performing a series of tests at fixed times with varying concentrations or at fixed concentrations with varying exposure times as suggested by the lines on the surface in figure 25.

The maximum exposure time to which the animals should be subjected was set at 30 minutes in this test method. This 30 minute exposure is shown as a bold line in figure 25. The 50% lethality line drawn on the surface represents the combinations of time and concentration at which 50% of the animals die. The LC_{50} is the point of intersection of the 50% lethality line and the 30 minute exposure line. For large values of time, the distance between the lethality surface and the zero concentration plane (x') asymptotically approaches the concentration threshold and is an indication of the toxicity of the combustion products for long exposure times.

If the shape of the response surfaces were the same for all materials, then one could assume that the rank-order of materials would not change in moving up or down from 30 minutes. In fact, the surfaces are likely to be somewhat different and the rank-order may indeed change. If there is a question about toxicity for a different time, the LC_{50} should be redetermined for that time. If characterization of a large portion of the response surface is desired, LC_{50} data should be obtained at several additional times. The cost of doing these experiments will be higher than for just the 30 minute test; the increased assurance that false negatives will not occur must be weighed against that increase in cost.

As an optional procedure in this test method, a single 10 minute exposure was chosen at the approximate maximum capacity of the furnace for most materials (30 mg/l). This 10 minute exposure was performed on PVC and PVC with zinc ferrocyanide to illustrate the capability of the test to further differentiate between the combustion toxicity of materials

which had comparable LC_{50} 's for the 30 minute exposure and 14 day observation period. Table 24 shows the results of this test. PVC with zinc ferrocyanide produced 100% incapacitation (measured by righting reflex of the animals) in the 10 minutes at all three temperatures, flaming, non-flaming and 440°C. Although some deaths occurred during the 10 minute exposures, 100% of the animals were dead by the end of the 14 days following this 10 minute insult. In all cases, sufficient hydrogen cyanide was produced to account for deaths in a 30 minute exposure, but whether these concentrations of hydrogen cyanide were sufficient to cause the 10 minute deaths is not known.

The PVC tested in this study, on the other hand, caused no incapacitation or death during the exposure. Only one out of the 30 animals tested died during the 14 day post-exposure period. This PVC did not produce effective concentrations of toxicants as rapidly as the PVC with zinc ferrocyanide.

On the basis of these experiments, the decision was made to add this additional 10 minute experiment at a 30 mg/l concentration as an optional supplement to the test method to provide a qualitative indication of the performance of materials that produce toxicants rapidly. This additional test may be performed on materials except those with an LC_{50} (30 minutes and 14 days) of less than 2 mg/l. Because of the possible hazard to laboratory personnel, these materials, which are toxic at very low concentrations, should not be examined at the 30 mg/l concentration. The 10 minute exposure test should be run at least twice at the temperature condition (flaming or non-flaming) which proved to be most toxic in the LC_{50} determinations. If 50% or more of the animals from all the 10 minute exposure tests die, the material would be considered capable of rapidly producing toxicants.

6.5 SUMMARY OF ANIMAL MEASUREMENTS

The following list summarizes the major decisions regarding the animal measurements:

- (1) one inbred animal species should be used,
- * (2) adult male rats weighing between 225 and 325 grams and 3-4 months of age are designated,
- (3) the choice of rat strain is not specified, but Fischer 344 is recommended,
- (4) animals should be kept 10 days before experiments and weighed daily from day of arrival to the end of the 14 day post-exposure observation period,
- * (5) animals used for blood measurements should not be kept for the 14 day post-exposure observation period,
- * (6) the biological endpoint should be the LC_{50} calculated for the 30 minute exposure and 14 day post-exposure observation period; the biological endpoint should not be the EC_{50} , which is based on percent of animals incapacitated, nor the time-to-incapacitation, and
- * (7) a 10 minute animal exposure to 30 mg/l has been added to the test procedure as an optional supplement to provide a qualitative indication of the performance of materials that produce effective concentration of toxicants rapidly.

7.0 BIOLOGICAL MEASUREMENTS

7.1 BLOOD ANALYSIS

Carbon monoxide has been implicated as the primary toxicant responsible for fire deaths [27, 6]. Our experimental results on animals presented here show that levels of carboxyhemoglobin (COHb) found in the blood in many smoke inhalation cases are not sufficient to account totally for the resultant deaths. While CO is definitely a contributing agent in many of these fire fatalities, other toxicants and/or factors, such as heat stress, oxygen deficiency, and prior health problems, also need to be considered.

*New procedures or procedures that have been modified from those proposed in the original test method [7, Appendix A].

Hemoglobin, the oxygen-carrying protein of red blood cells, has a reversible affinity for CO which is approximately 200-250 times its affinity for O₂ [28]. The binding of CO to hemoglobin results in the rapid formation of COHb and the prevention of the formation of oxyhemoglobin (O₂Hb), the means whereby oxygen is normally transported to the cells. In the presence of CO both the oxygen carrying capacity of the blood and its oxygen releasing capacity are reduced, producing an oxygen deficiency at the cellular level greater than that produced by an equivalent reduction in the concentration of atmospheric oxygen or concentration of hemoglobin.

Each laboratory participating in the interlaboratory evaluation of the test method analyzed the animal blood for COHb and O₂Hb. These blood values are influenced by the method and the time of sampling.

Various methods were used to obtain blood. If the animals were cannulated, arterial blood was taken during the exposure without removing the animals from the exposure chamber. If the animals were not cannulated, the method of sampling blood was left to the discretion of the investigator. Post-exposure cardiac puncture, intraorbital venous puncture, or the dorsal aorta were used to obtain blood. The values of O₂Hb will depend on whether the blood sample is arterial, venous or a mixture. Also, anesthesia supplied to the animal before surgery to obtain blood from the dorsal aorta or the heart causes a decrease in the respiratory rate and a lower O₂Hb value. Therefore, unless arterial cannulation is required by the test method, the O₂Hb will not be reproducible across laboratories. Consequently, the test method was modified to require only COHb measurements which show only minor differences between arterial and venous blood.

The time at which blood is taken also influences blood COHb and O₂Hb values. Blood from live cannulated animals should be taken just before the end of the exposure. Non-cannulated animals have to be removed and some recovery can occur in live animals before the blood is sampled. The animals recover rapidly from carbon monoxide exposure and

the levels of COHb reflect this recovery. Figure 26 shows the NBS results on the formation of COHb and reduction of O₂Hb during a 30 minute exposure to an average concentration of 4100 ppm of pure CO. The very rapid recovery rate following the exposure is also shown and emphasizes the need for rapid blood sampling procedures. Figure 27 shows the percent COHb determined at the end of each exposure to non-flaming Douglas fir plotted against the average concentration of CO integrated over the 30 minute exposure for cannulated and non-cannulated animals from seven laboratories. The solid and dashed lines represent the least squares linear regression analyses of all the points from cannulated and non-cannulated animals, respectively, until the loading where COHb levels off. The animals did not load more than 86% COHb. For cannulated animals, COHb values are higher because these animals experience no recovery period. COHb values are generally lower for non-cannulated animals because the animals must be removed from the chamber before blood is taken, allowing some recovery to occur.

The test method, therefore, provides that when blood is taken from non-cannulated animals, it must be obtained within five minutes of the end of the exposure. Regardless of cannulation, all animals that are used for blood sampling are not to be kept for the 14 day observation period as both the process of cannulation and the removal of blood have added to the toxicological insult.

7.2 CORRELATION OF COHb, CO, AND TOXICITY

Pure gas experiments using the NBS equipment (except the furnace) have shown that an average concentration of 5000 ppm of CO is necessary to kill 50 percent of the rats in 30 minutes. This CO concentration results in an average COHb level of 89 percent in the blood immediately prior to the end of the 30 minute exposure (cannulated animals). The COHb level immediately prior to the end of the 30 minute exposure at the LC₅₀ mass loading should then be an indicator of the extent to which CO contributes to the overall combustion product toxicity of a material. Figure 28 illustrates how this COHb level can be determined. The COHb

levels that are obtained at the end of each exposure are plotted against the mass loading/chamber volume. Then the LC_{50} (30 minutes + 14 day) value is superimposed on the graph and the percent COHb at that mass loading is determined. The COHb values for the EC_{50} and LC_{50} (30 minute) values can be obtained from this curve in a similar manner.

Tables 25 and 26 show the COHb levels obtained in this way using the NBS test results and corresponding average CO, average HCN, and LC_{50} (30 minutes + 14 days) for flaming and non-flaming combustion for eleven of the materials used in the ILE. The NBS pure CO study showed no post-exposure deaths. When post-exposure deaths are observed, there are almost certainly other contributing factors.

Within-exposure deaths occurring at the LC_{50} (30 minutes + 14 days) together with COHb levels below 89 percent and CO concentrations less than 5000 ppm also indicate that factors in addition to CO must be considered when one is evaluating the toxicity of combustion products.

Figure 29 shows, for NBS measurements, the relationships between COHb and average CO concentration at the LC_{50} (30 minutes + 14 day) values of the eleven materials under both flaming and non-flaming conditions. The results for materials which produce HCN or HCl are identified in figure 29. This further illustrates that the COHb measurement required in the test method can be a useful indicator of the likely presence of other toxic gases, although it should not be used to rule out the presence of other gases.

8.0 SUMMARY OF CHANGES TO THE TEST METHOD

The results of early work, sponsored by the Products Research Committee, on the design of a test procedure were published as a report of the National Bureau of Standards [7]. Subsequent work at NBS and technical information provided by an ad hoc working group representing academia, industry, and government resulted in the following changes to the earlier procedure:

- °examination of materials at 440°C is now optional,
- °the recommended size of the cup furnace has been increased from 300 ml to 1000 ml,
- °the average chamber temperature in the vicinity of the noses of the animals for the 30 minute exposure must be below 40°C,
- °the minimum average oxygen level permitted in the chamber is 16%,
- °the weight range of the rats has been increased from 200-300 grams to 225 to 325 grams and an age restriction to between 3 and 4 months has been introduced,
- °for the 30 minute exposures, the only biological endpoint now required is an LC₅₀ (the concentration which causes lethality in 50% of the animals in the 30 minute exposure including a 14 day post-exposure observation period). The incapacitation endpoint has been eliminated,
- °an optional animal exposure at a concentration of 30 mg/l for 10 minutes followed by a 14 day post-exposure observation period has been added for some situations,
- °blood from non-cannulated animals must be taken in the first 5 minutes after the end of the exposure,
- °oxyhemoglobin and total hemoglobin measurements are no longer required, and
- °pathological examination of the animals that die during exposure or are sacrificed is now optional.

9.0 FUTURE WORK

The test method presented in this report can be used to assess the toxicity of combustion products of materials under specified laboratory conditions and is just a first step towards predicting the toxic hazard that a material would pose in an actual fire. To evaluate the toxic hazard, a technique must be developed to combine information on the quantity of material, its configuration, the proximity of other combustibles, the volume of the compartment to which the combustion products may spread, the ventilation conditions, the ignition and combustion properties of the material, the presence of ignition sources, the presence of fire protection systems, the occupancy of the building, and other pertinent factors.

The test method itself has certain limitations resulting from the use of the cup furnace. These limitations relate to the testing of low density materials, many composite materials, and some products with layered construction. A radiant heating system as an alternate combustion module may be better able to address these problems and will be studied further at NBS.

In assessing the overall toxic hazard posed by a material or combination of materials the rate of release of toxicants is an important factor in the determination of the time available for egress from a burning structure. A system to measure the continuous weight loss of a sample during a test would provide some additional information on this subject. NBS plans to study this system as a part of its work on a radiant furnace.

The temperature of the gases in the exposure chamber can influence the effect on the animals. Improved control of this temperature would enable the test method to be used to determine temperature effects alone and in conjunction with toxicants.

A base of information on the toxic effects of known concentrations of pure gases and combinations of gases at different atmospheric temperatures in this system is needed as background for the evaluation of total toxic hazard.

Additional study of the 10 minute test or other means for assessing the rapid evolution of effective concentrations of toxic combustion products is necessary.

In the evaluation of total toxic hazard generated by a fire situation, an incapacitation model should provide additional information necessary to the prediction of safe egress. At the present time, the behavioral incapacitation models that have been studied are not significantly more sensitive than the measurement of lethality. Additional research in the area of incapacitation models is needed.

10.0 ACKNOWLEDGMENTS

We gratefully acknowledge the help of Mr. Emil Braun and Mr. Richard Peacock for designing and writing the many computer programs which improved the efficiency of data collection and analysis. We also acknowledge Dr. James J. Filliben for the many helpful discussions and guidance with regard to statistics in general and the BLUE technique in particular. In addition, we thank Ms. Mary Diephaus and Ms. Alison Durham for their expert use of computer graphics in preparing many of the figures.

11.0 REFERENCES

1. Highlights of fire in the United States, 2nd Edition. Federal Emergency Management Agency, U.S. Fire Administration; 1981 April 26 p.
2. Preview, Residential Fires in the United States, Federal Emergency Management Agency, U.S. Fire Administration, 1979.
3. Birky, M. M. Hazard characteristics of combustion products in fires: the state-of-the-art review. Nat. Bur. Stand. (U.S.) NBSIR 77-1234; 1977 May. 48 p.
4. Committee on Fire Safety Aspects of Polymeric Materials. Smoke and toxicity (combustion toxicology of polymers). Vol. 3, Publication NMAB 318-3, Nat. Acad. Sci., Westport, CT: Technomic Publishing Co.; 1978. 55 p.
5. Committee on Fire Toxicology. Fire Toxicology: methods for evaluation of toxicity of pyrolysis and combustion products. Report No. 2, Nat. Acad. Sci., Washington, D.C. 1977 August. 34 p.
6. Lyons, J. W.; Fristrom, R. M.; Becker, W. E.; Clayton, J. W.; Emmons, H. W.; Glassman, I.; Graham, D. L.; Long, R.; McDonald, D. W.; Nadeau, H. G.; Products Research Committee. Fire research on cellular plastics: the final report of the Products Research Committee. [Washington, D.C.], 1980, 213 p.
7. Birky, M. M.; Paabo, M.; Levin, B. C.; Womble, S. E.; Malek, D. Development of recommended test method for toxicological assessment of inhaled combustion products. Nat. Bur. Stand. (U.S.) NBSIR 80-2077; 1980 September. 63 p.

8. Kimmerle, M.G., Aspects and methodology for the evaluation of toxicological parameters during fire exposure. J. Comb. Tox. 1: 4-51; 1974.
9. Alarie, Y. C.; Anderson, R. C. Toxicologic and acute lethal hazard evaluation of thermal decomposition products of synthetic and natural polymers. Tox. Appl. Pharm. 51: 341-362; 1979.
10. Fire tests - reaction to fire - ignitability of building products. Draft Technical Report DTR 5657, ISO/TC 92 SC 1 N36, 1981 June.
11. Potts, W. J.; Lederer, T.S. A method for comparative testing of smoke toxicity. J. Comb. Tox. 4: 114-162; 1977.
12. MacFarland, H. N. Respiratory toxicology, chapter 5 in Essays in Toxicology, W. Hayes, ed. New York: Acad. Press; 7: 121-154; 1976.
13. Standard guide for measurement of gases present or generated during fires. ASTM Standard E 800-81; 1981.
14. Paabo, M.; Birky, M. M.; Womble, S. E. Analysis of hydrogen cyanide in fire environments. J. Comb. tox. 6: 99-108; 1979.
15. Matijak-Schaper, M.; Alarie, Y. A. Toxicity of carbon monoxide, hydrogen cyanide and low oxygen. J. Comb. Tox. 9: 21-61; 1982.
16. Hansen, C. T.; Potkay, S.; Watson, W. T.; Whitney, R. A. NIH rodents, 1980 catalogue. Dept. Health and Human Services, Public Health Service, NIH Publication No. 81-606. 1981 April. 253 p.
17. Committee on Care and Use of Laboratory Animals; Guide for the care and use of laboratory animals. DHEW publication No. (NIH) 78-23. U.S. Dept. of HEW, Public Health Service, National Institutes of Health. 1978.

18. Packham, S. C.; Frens, D. B.; McCandless, J. B.; Petajan, J. H.; Birky, M. M. A chronic intra-arterial cannula and rapid technique for carboxyhemoglobin determination. *J. Comb. Tox.* 3: 471-478; 1976.
19. Smith, P. W.; Crane, C. R.; Sanders, D. C.; Abbott, J. K.; Endecott, B. Effects of exposure to carbon monoxide and hydrogen cyanide. Proceedings of symposium on Physiological and Toxicological Aspects of Combustion Products; 1974 March 18-20; Salt Lake City, Utah. *Nat. Acad. Sci. Washington, D.C.*, 1976, pp. 75-88.
20. Annau, Z. Behavioral toxicity of cellular plastics. Final report to Products Research Committee, Nat. Bur. Stand. 1979 June. 23 p.
21. Hartung, R.; Ball, G. L.; Boettner, E. A.; Rosenbaum, R.; Hollingsworth, Z. R. The performance of rats on a rotarod during exposure to combustion products of rigid polyurethane foams and wood. *J. Comb. Tox.* 4: 506-522; 1977.
22. Pryor, G. T.; Dilley, J. V.; McKee, R. G.; Martin, S. B. Behavioral techniques in fire toxicology. Proceedings of First California Conference on fire toxicity, 1979 August 21-22, San Francisco, California, pp. 1-27.
23. Packham, S. C.; Jeppsen, R. B.; McCandless, J. B.; Blank, T. L.; Petajan, J. H. The toxicological contribution of carbon monoxide as a component of wood smoke. *J. Comb. Tox.* 5: 11-24; 1978.
24. Packham, S. C.; Hartzell, G. E. Fundamentals of combustion toxicology in fire hazard assessment. *J. Test. & Eval.* 9: 341-347; 1981.
25. Sarhan, A. E.; Greenberg, B. G. Contributions to order statistics. New York, London: John Wiley & Sons, Inc.; 1962.

26. Litchfield, J.T., Jr.; Wilcoxon, F. A simplified method of evaluating dose-effect experiments. *J. Pharmacol. and Exp. Therapeut.* 96: 99-113; 1949.
27. Birky, M.M.; Halpin, B.M.; Caplan, Y.H.; Fisher, R.S.; McAllister, J.M.; Dixon, A.M. Fire fatality study. *Fire and Materials* 3: 211-217; 1979.
28. Ginsberg, M.D. Carbon monoxide, Chapter 26 in *Experimental and Clinical Neurotoxicology*. P.S. Spencer and H.H. Schaumburg, eds. Baltimore, London: Williams & Wilkins; 1980. pp. 374-394.
29. Products Research Committee. Materials bank compendium of fire property data. *Nat. Bur. Stand. (U.S.)*, [Washington, D.C.] 1980 February.

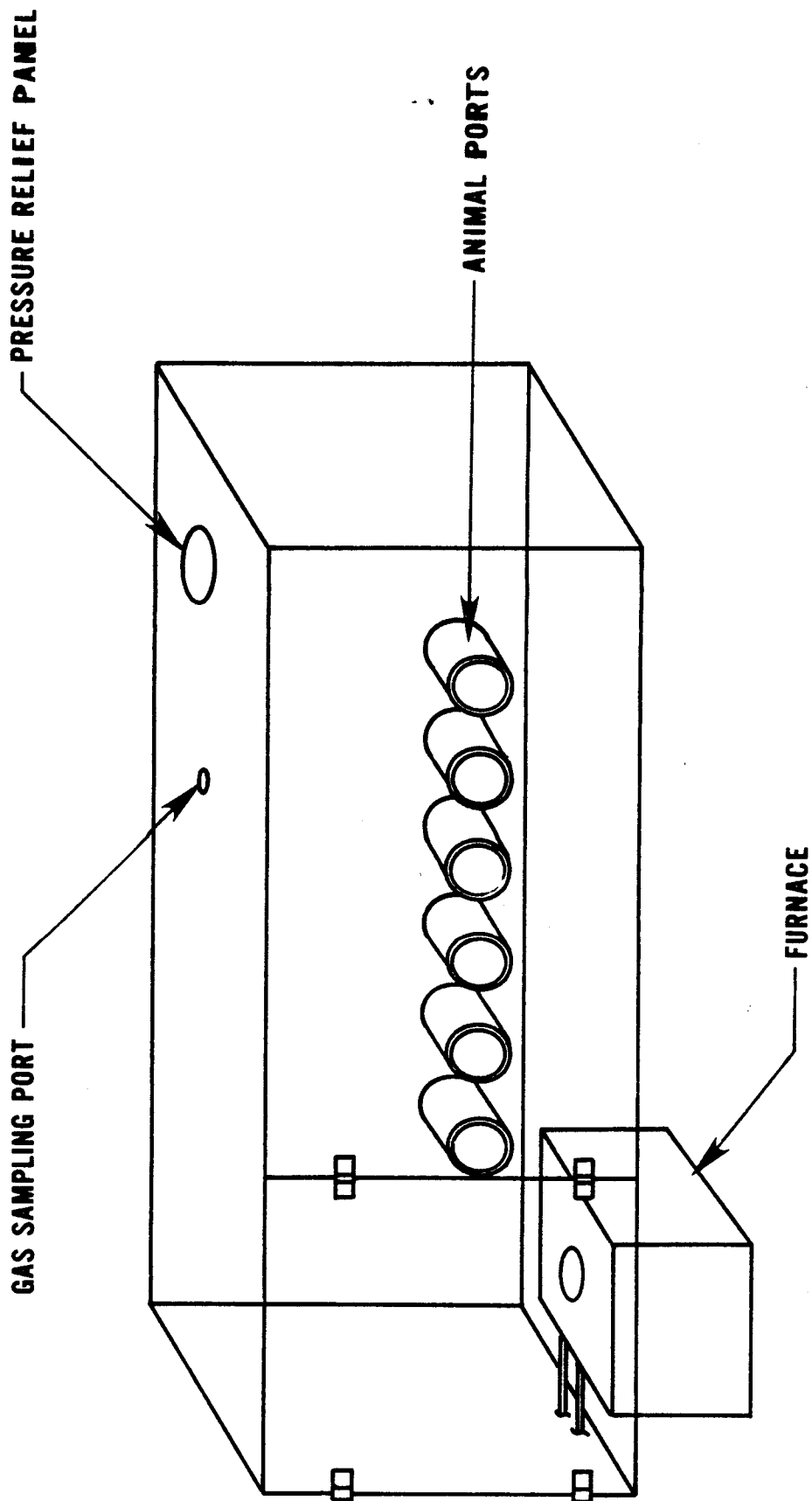
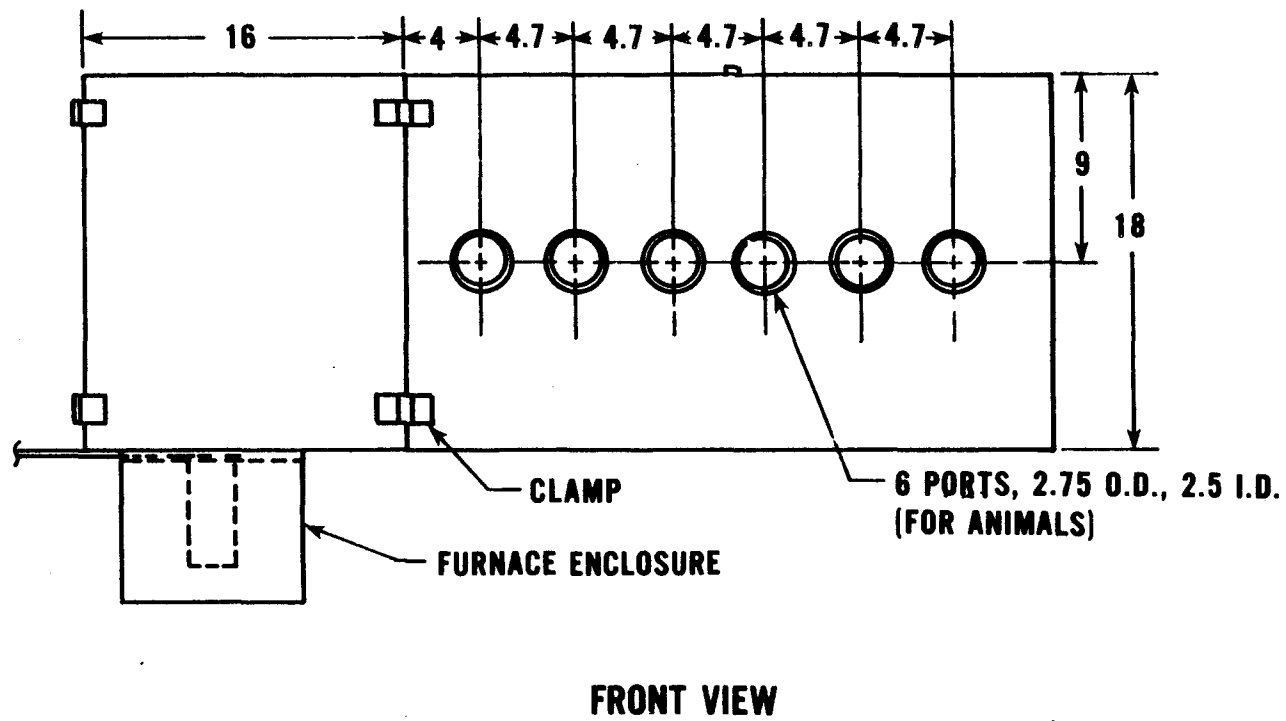
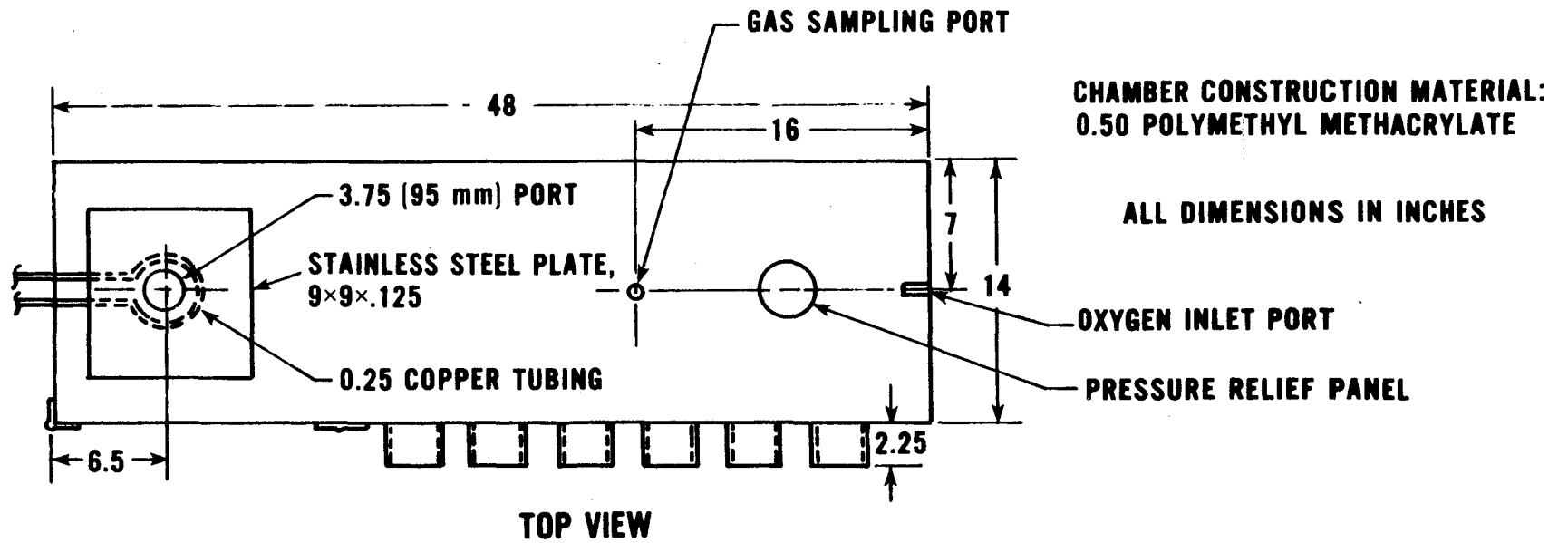

Figure 1. Exposure chamber.



75

Figure 2. Details of exposure chamber.

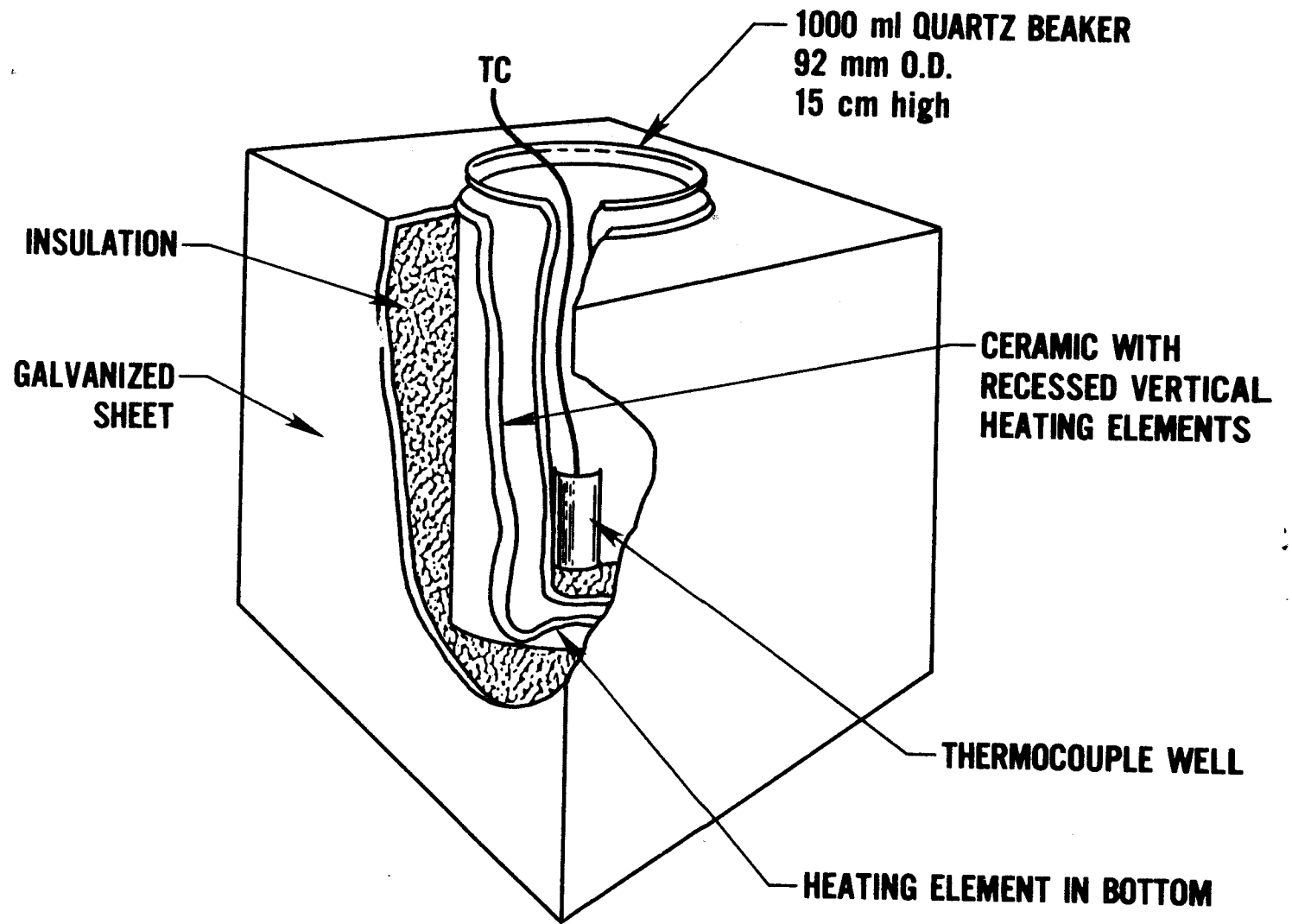
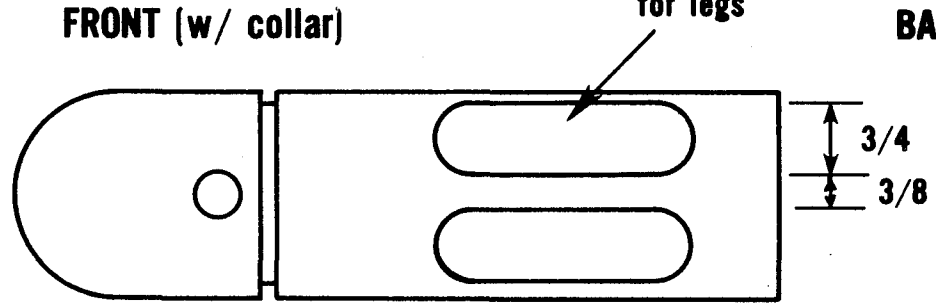
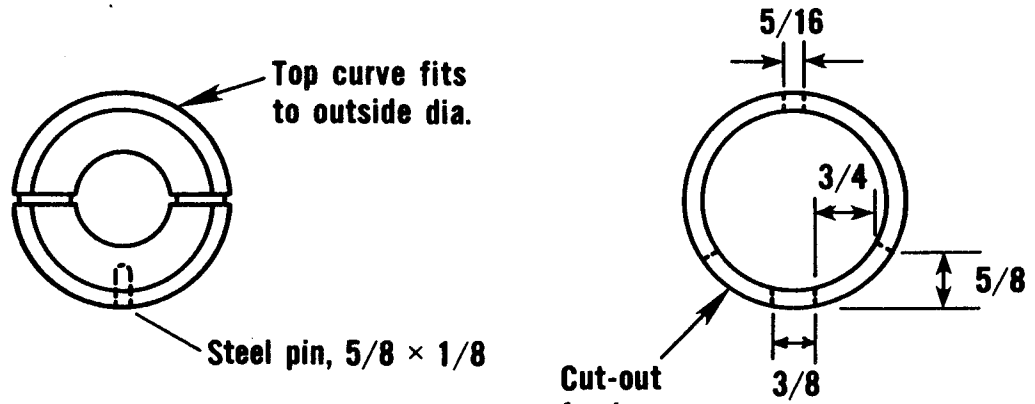
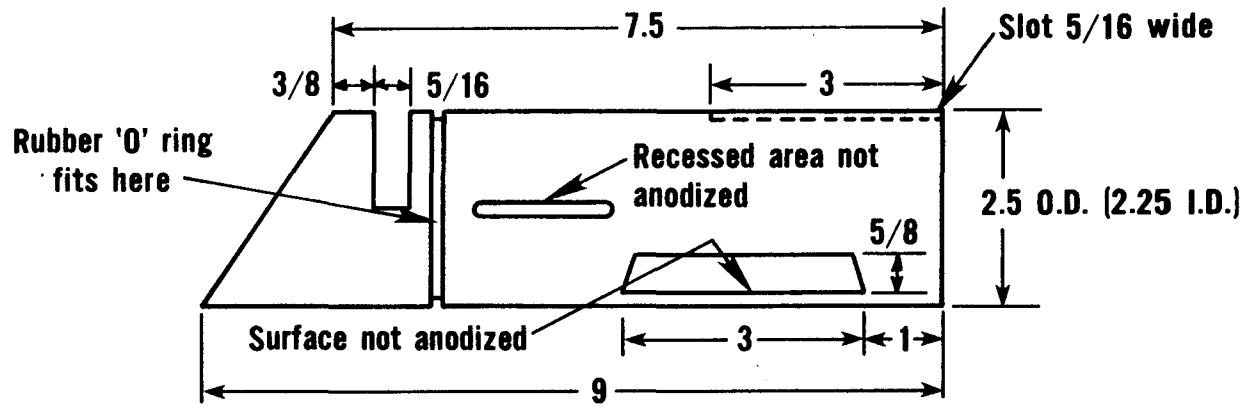
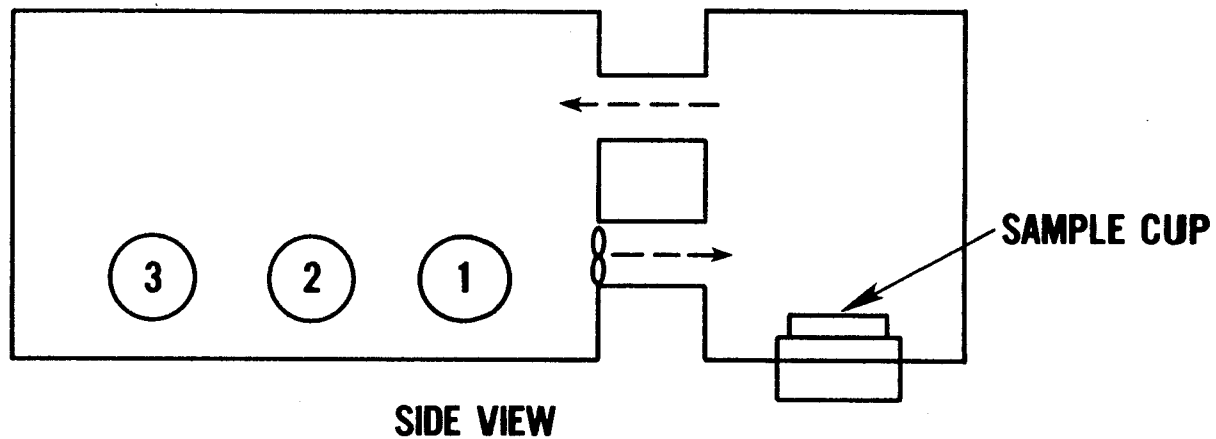

Figure 3. Pyrolysis/combustion furnace.



All dimensions in inches.

Figure 4. Schematic of animal restrainer.



78

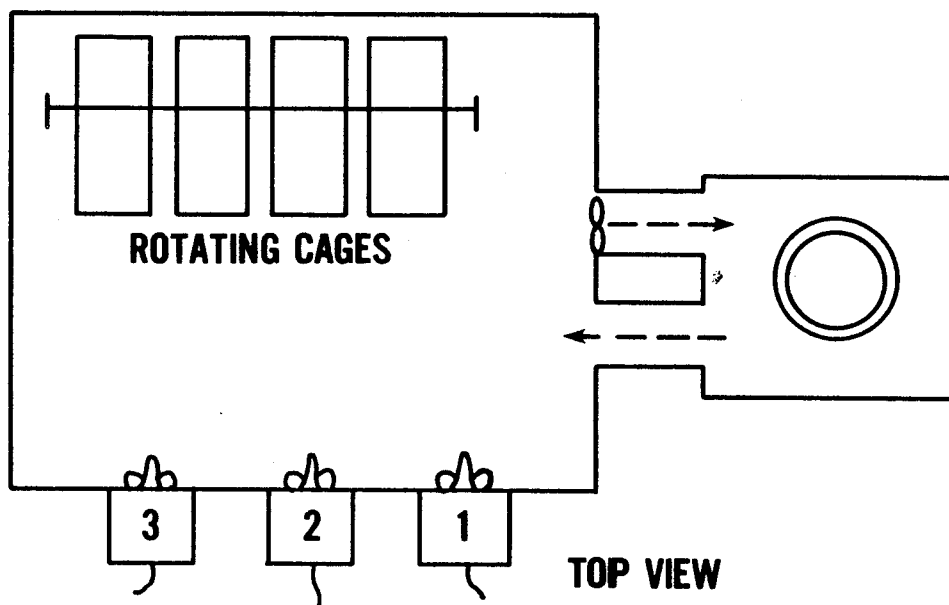

Figure 5. Exposure chamber with separate furnace.

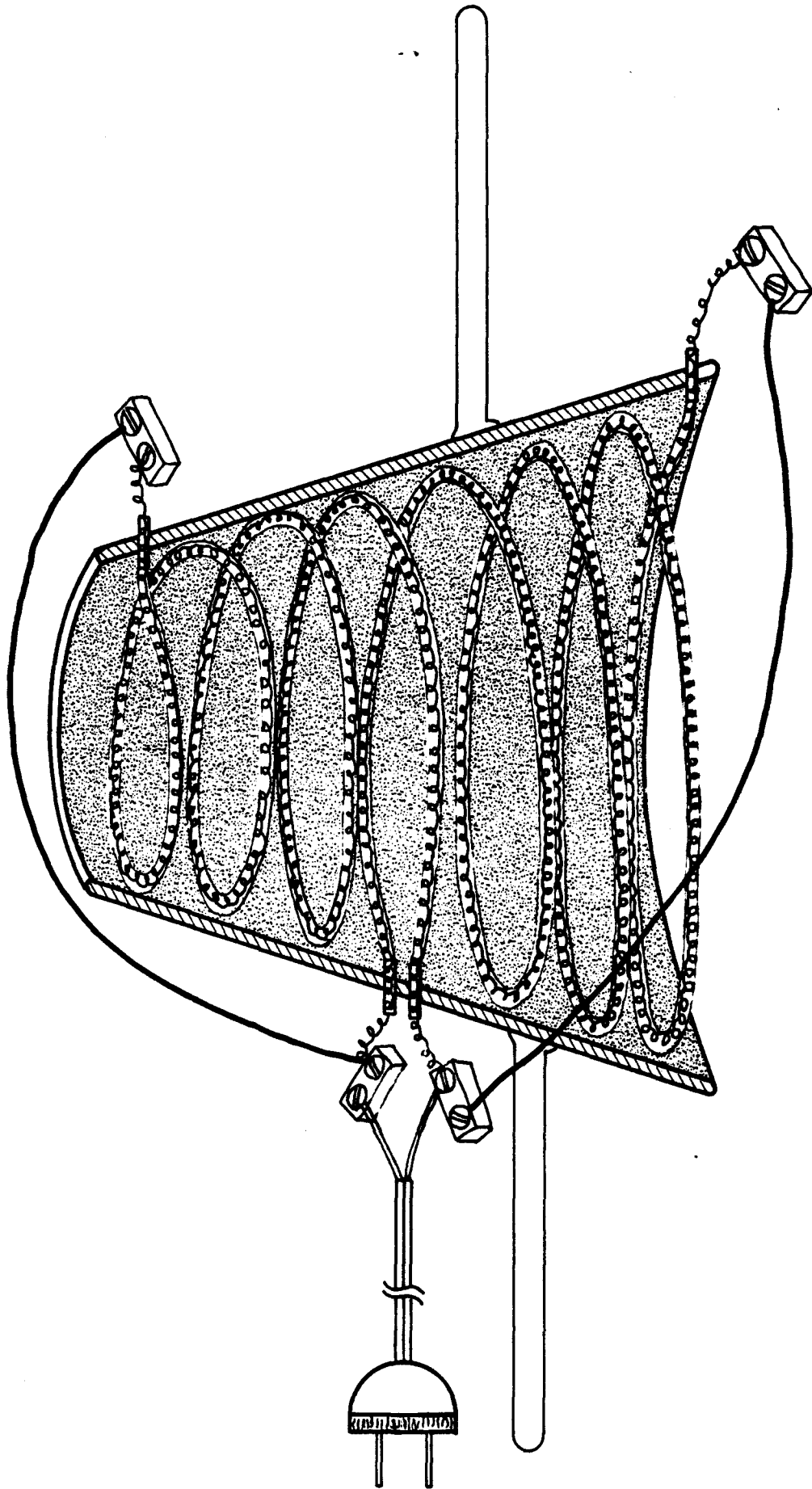

Figure 6. Radiant furnace cone.

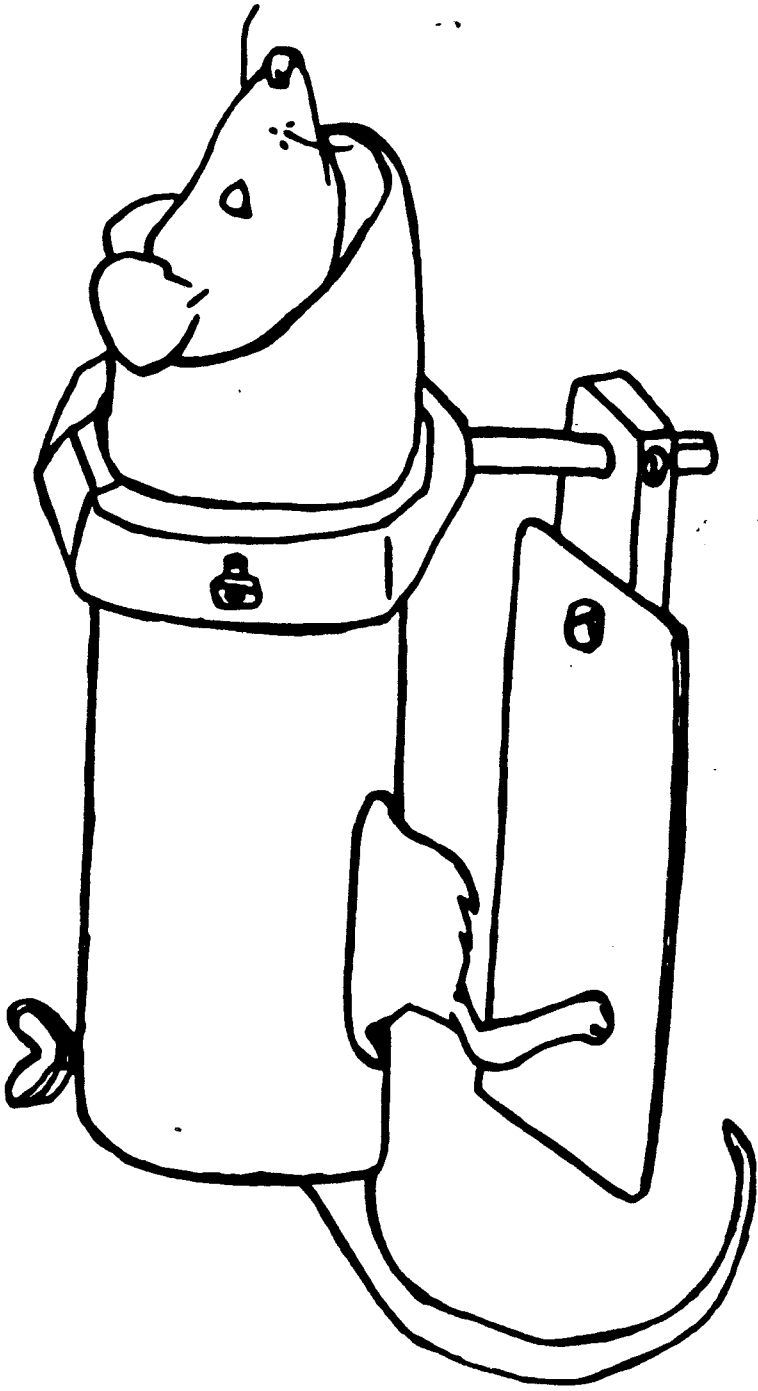

Figure 7. Animal restrainer.

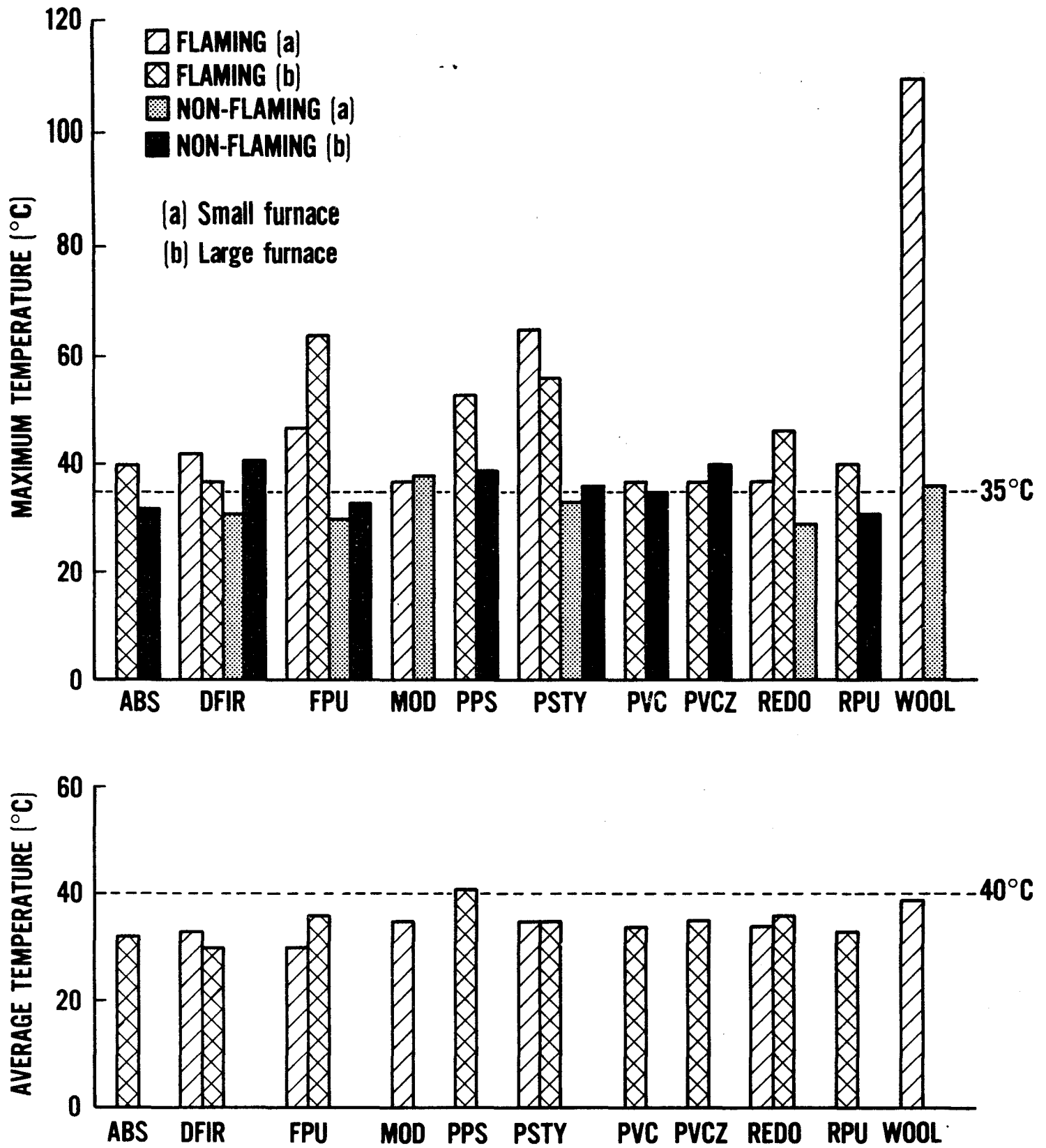

Figure 8. NBS exposure chamber temperatures at animal nose levels.
 Top: Maximum temperatures.
 Bottom: Average temperatures.

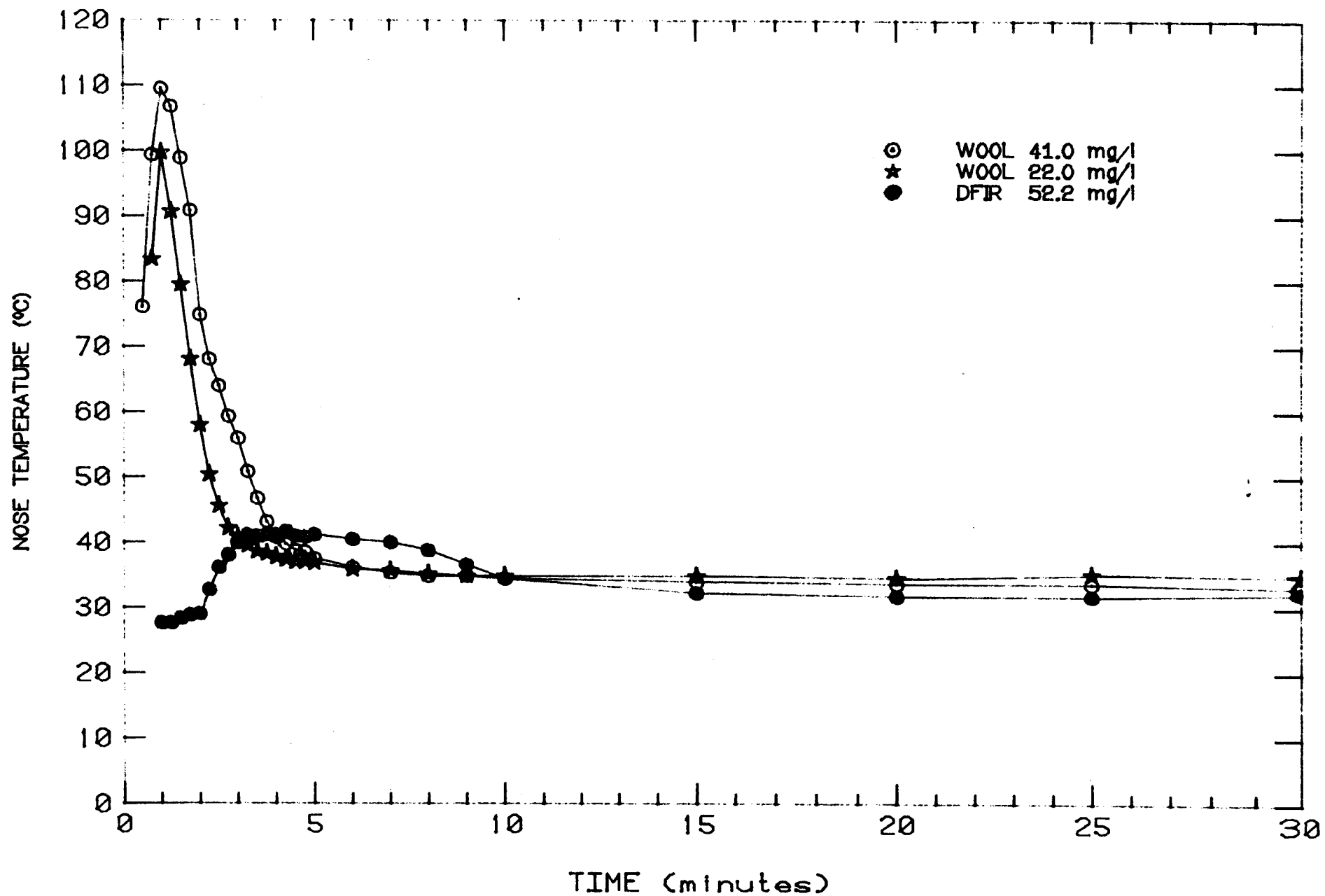

Figure 9. Chamber temperature at animal nose positions during 30 minute exposure to flaming wool and Douglas fir. (NBS data. Furnace temperature for flaming wool was 675°C and for flaming Douglas fir was 490°C.)

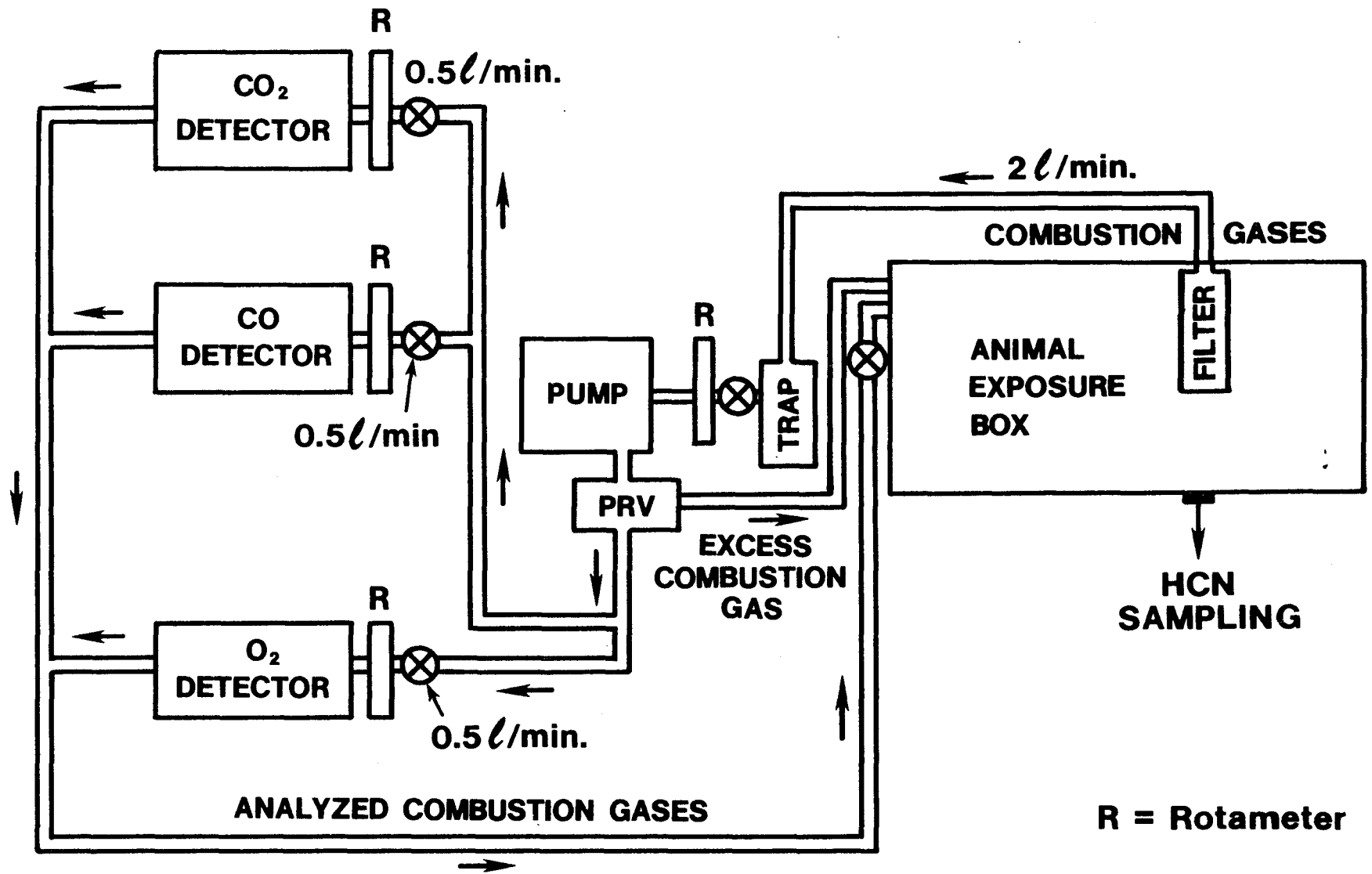

Figure 10. Schematic of NBS gas analysis system.

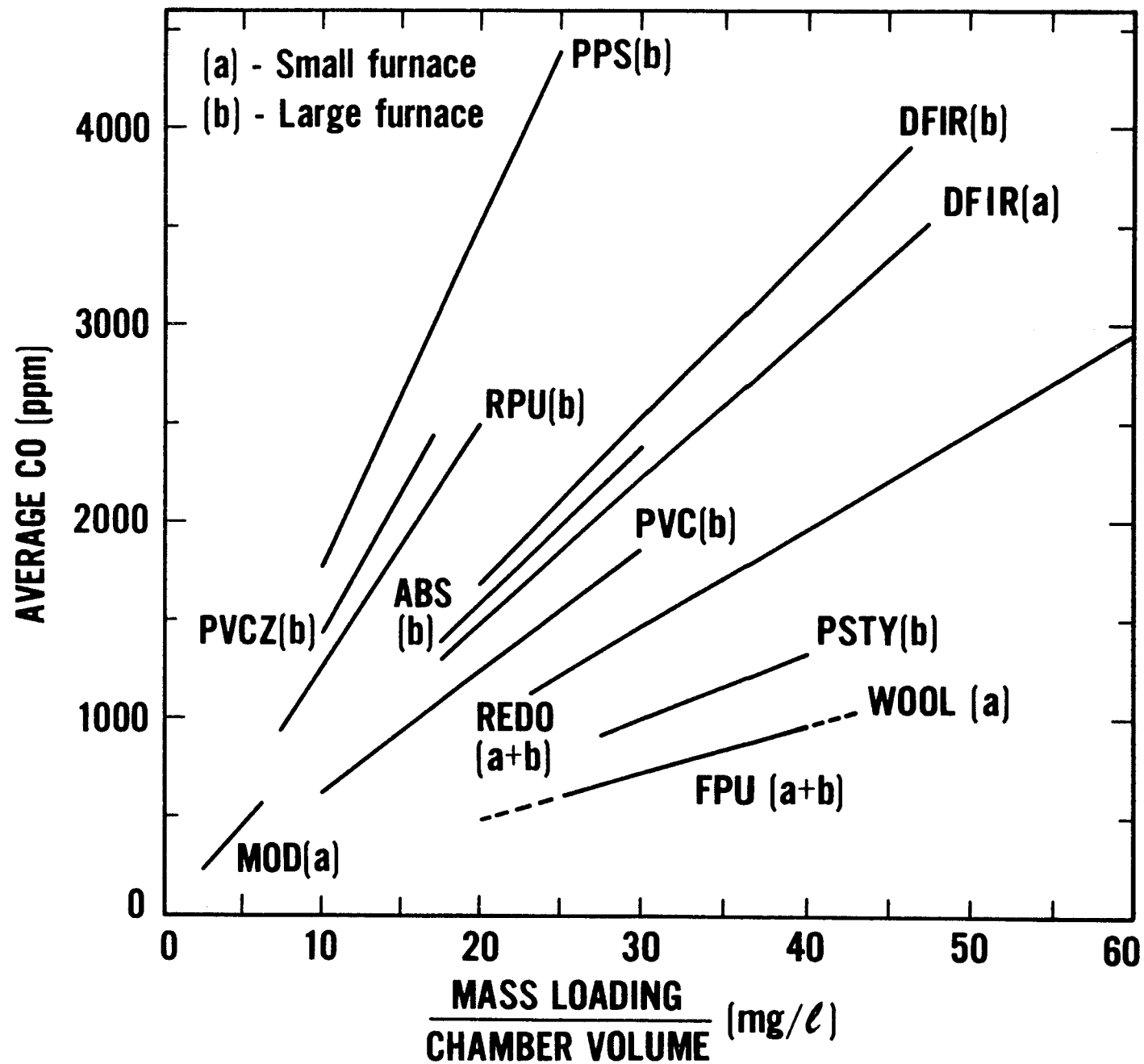

Figure 11. Carbon monoxide measurements averaged over the 30 minute flaming material decomposition plotted against the mass loading/chamber volume. The length of least squares linear regression line denotes the range of mass loadings tested.

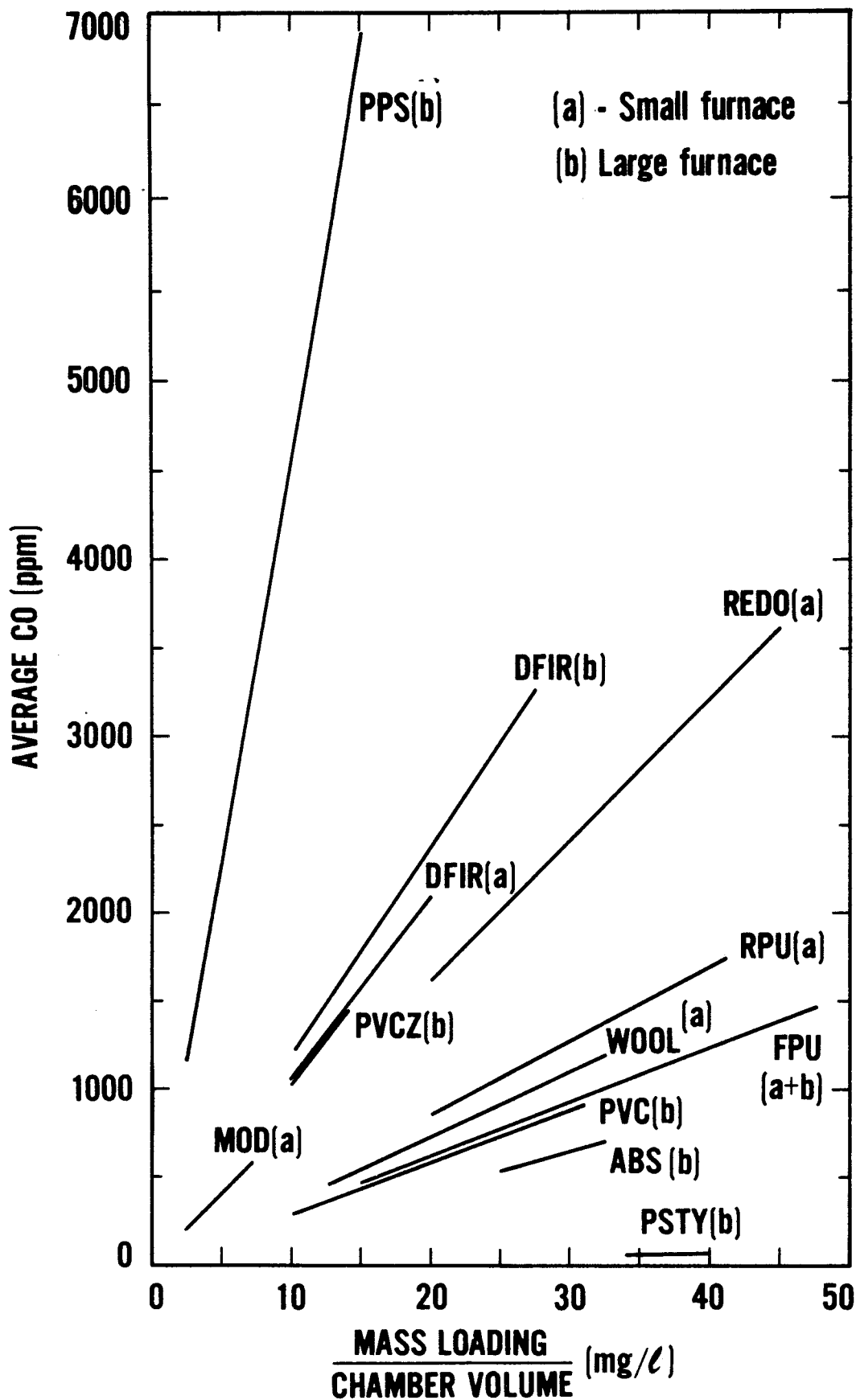

Figure 12. Carbon monoxide measurements averaged over the 30 minute non-flaming material decomposition plotted against the mass loading/chamber volume. The length of the least squares linear regression line denotes the range of mass loadings tested.

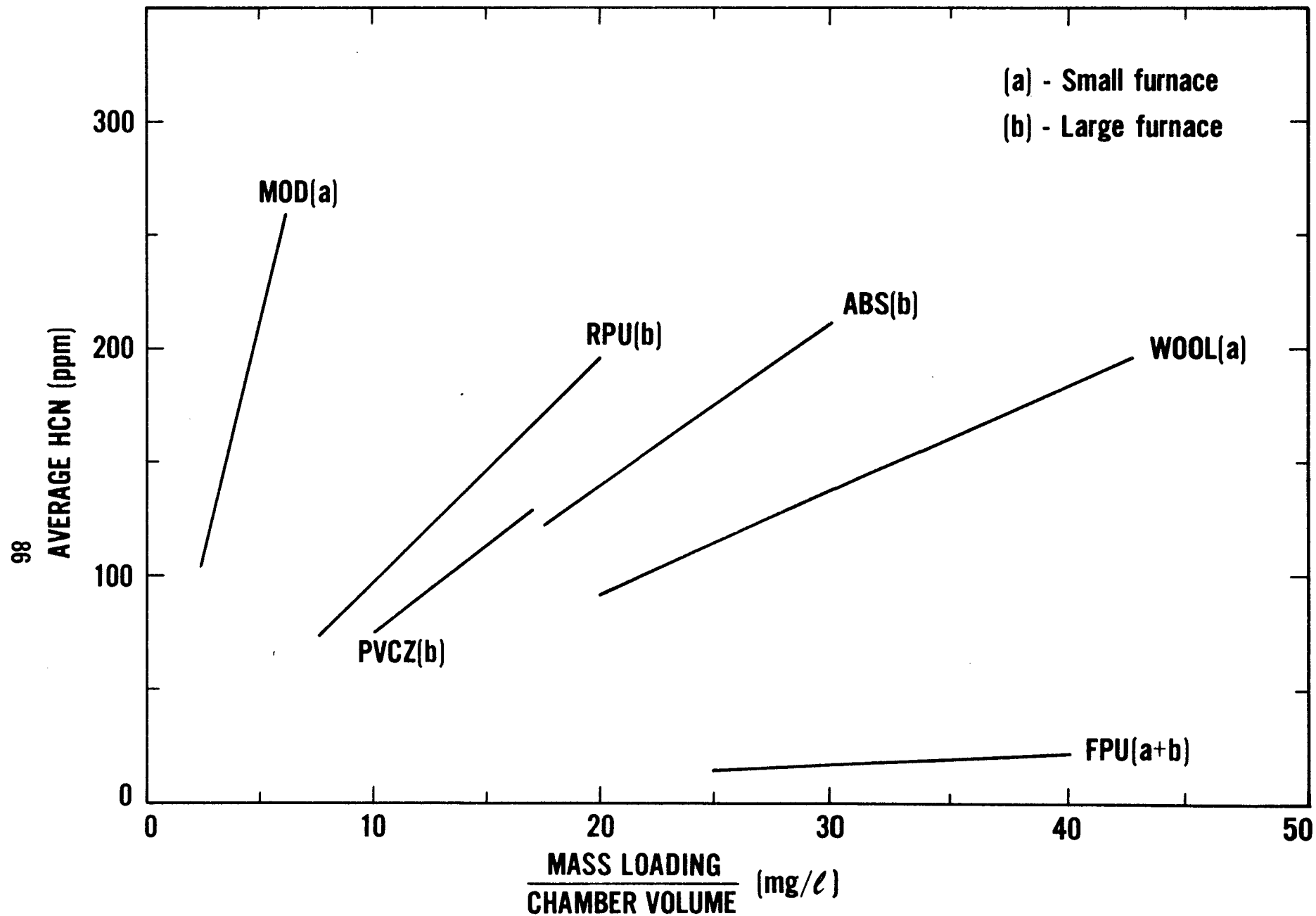

Figure 13. Hydrogen cyanide measurements averaged over the 30 minute flaming material decomposition plotted against the mass loading/chamber volume. The length of the least squares linear regression analysis line denotes range of mass loadings tested.

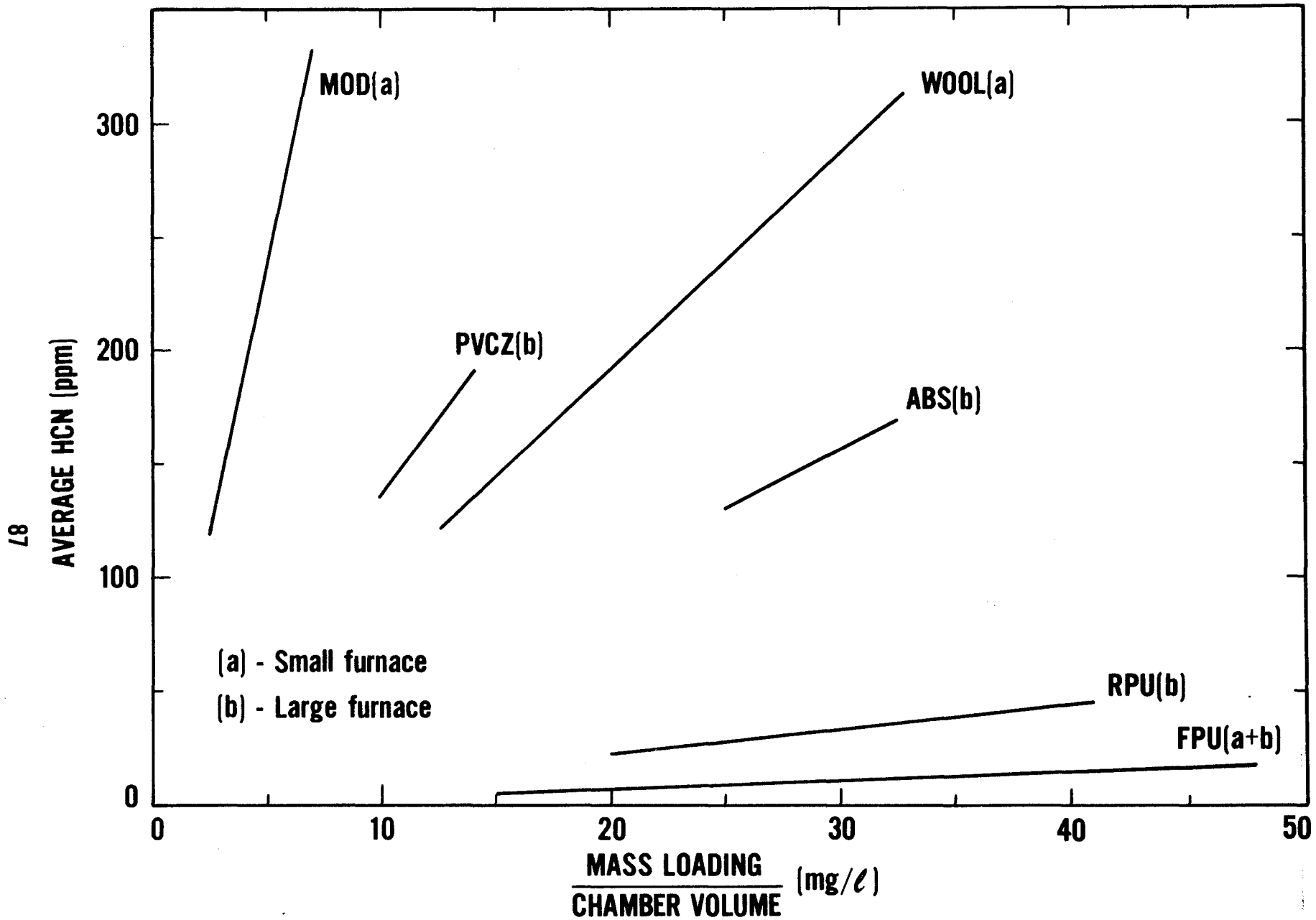

Figure 14. Hydrogen cyanide measurements averaged over the 30 minute non-flaming material decomposition plotted against the mass loading/chamber volume. The length of the least squares linear regression analysis line denotes range of mass loadings tested.

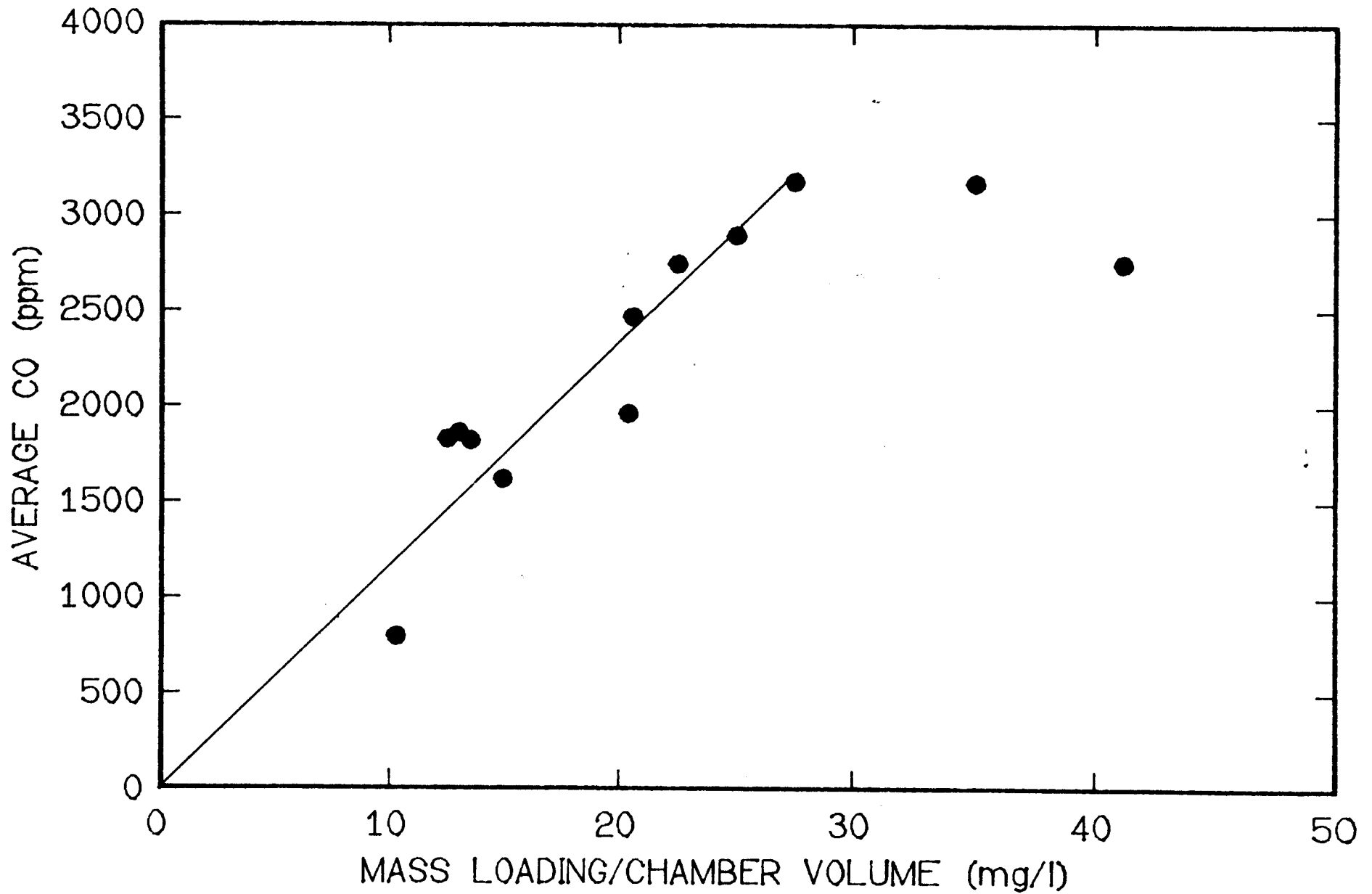

Figure 15. Overloading of furnace capacity as seen with non-flaming decomposition of Douglas fir in the NBS large furnace. Small furnace had similar results.

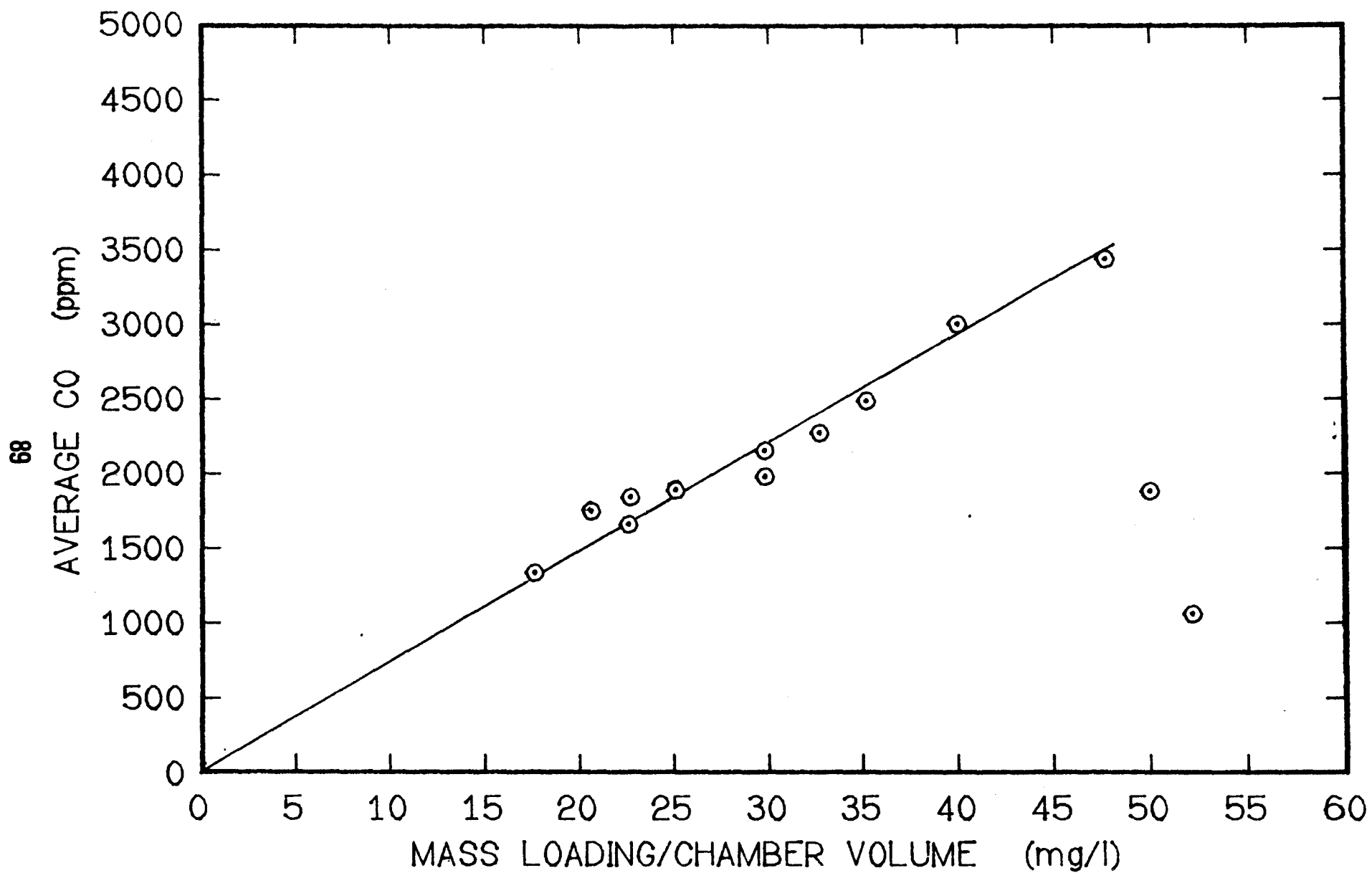

Figure 16. Overloading of furnace capacity as seen with flaming decomposition of Douglas fir in the NBS small furnace. Similar results were seen with large furnace.

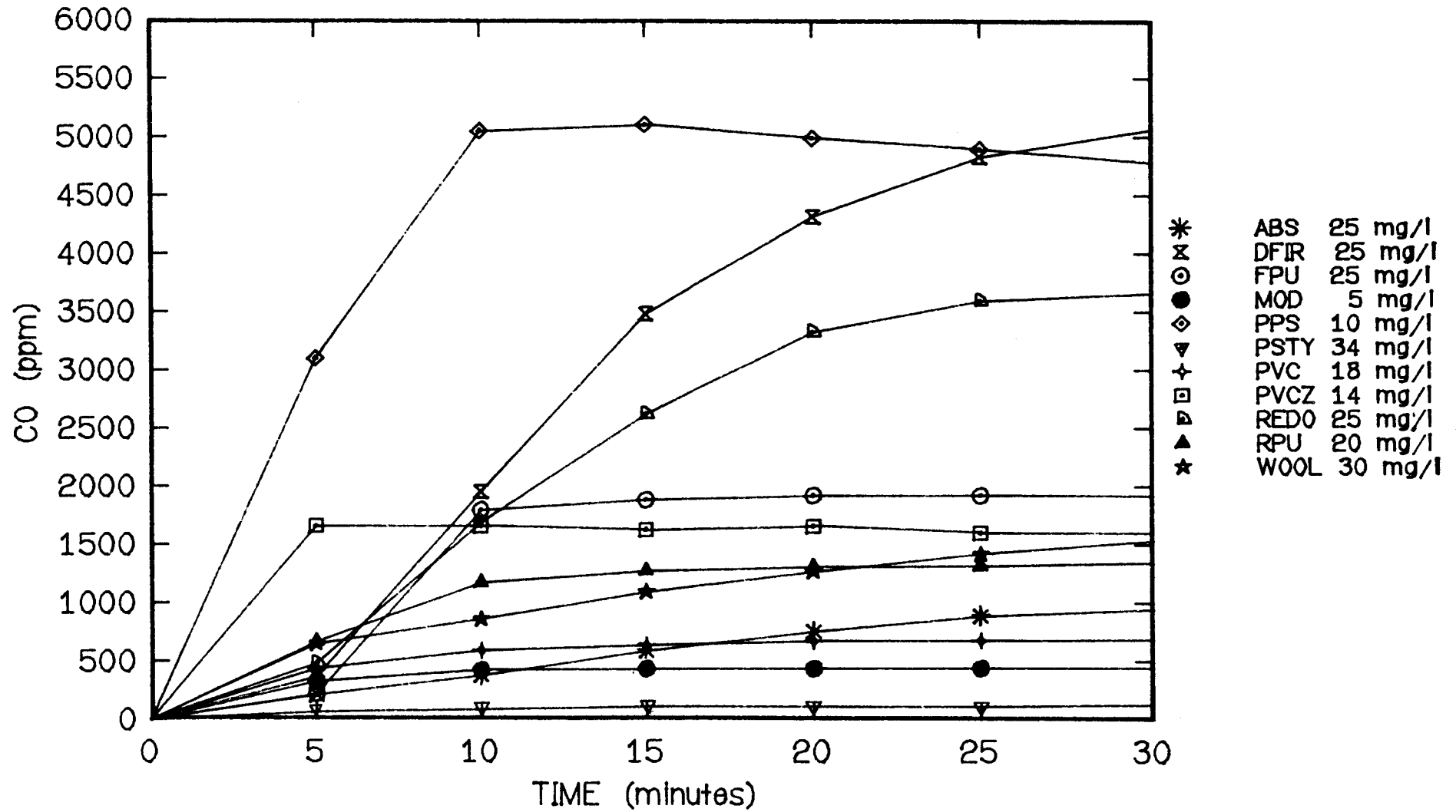

Figure 17. Carbon monoxide generation from ILE materials decomposed in the non-flaming mode at various mass loadings (NBS results).

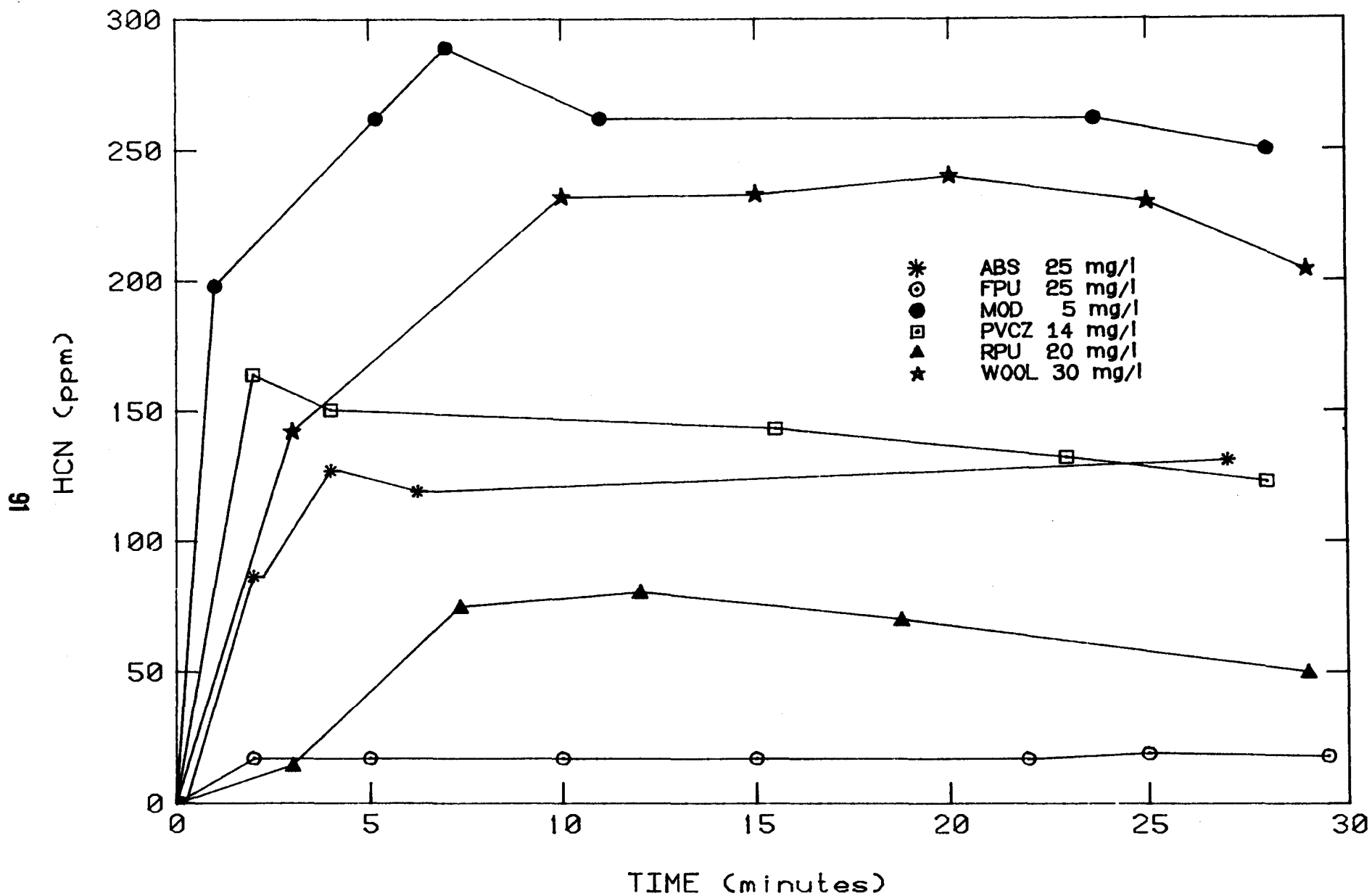

Figure 18. Hydrogen cyanide generation from ILE nitrogen-containing materials decomposed in the non-flaming mode at various mass loadings (NBS results).

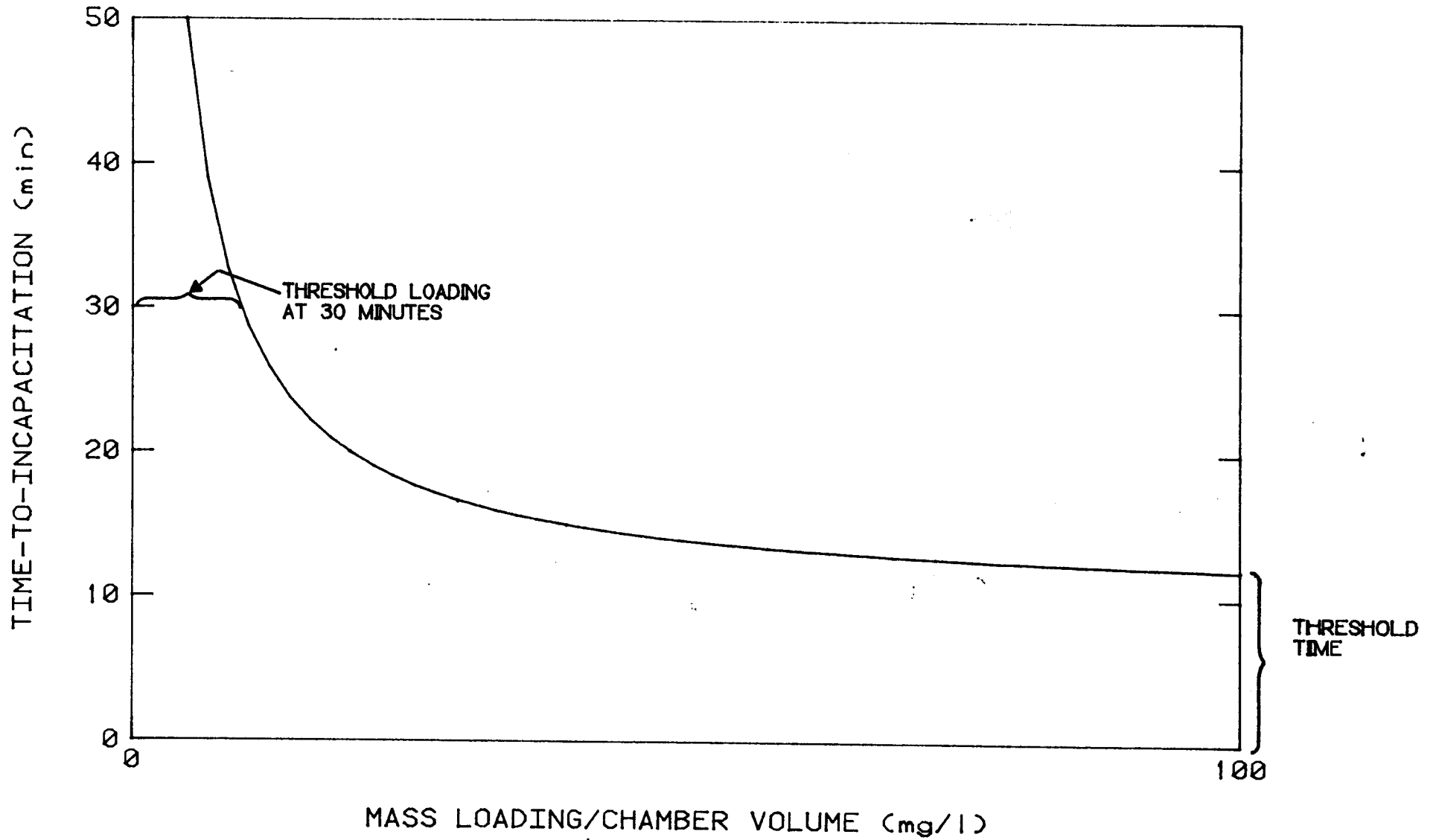

Figure 19. Hyperbola depicting asymptotes approaching a threshold mass loading at 30 minutes and a threshold time-to- incapacitation.

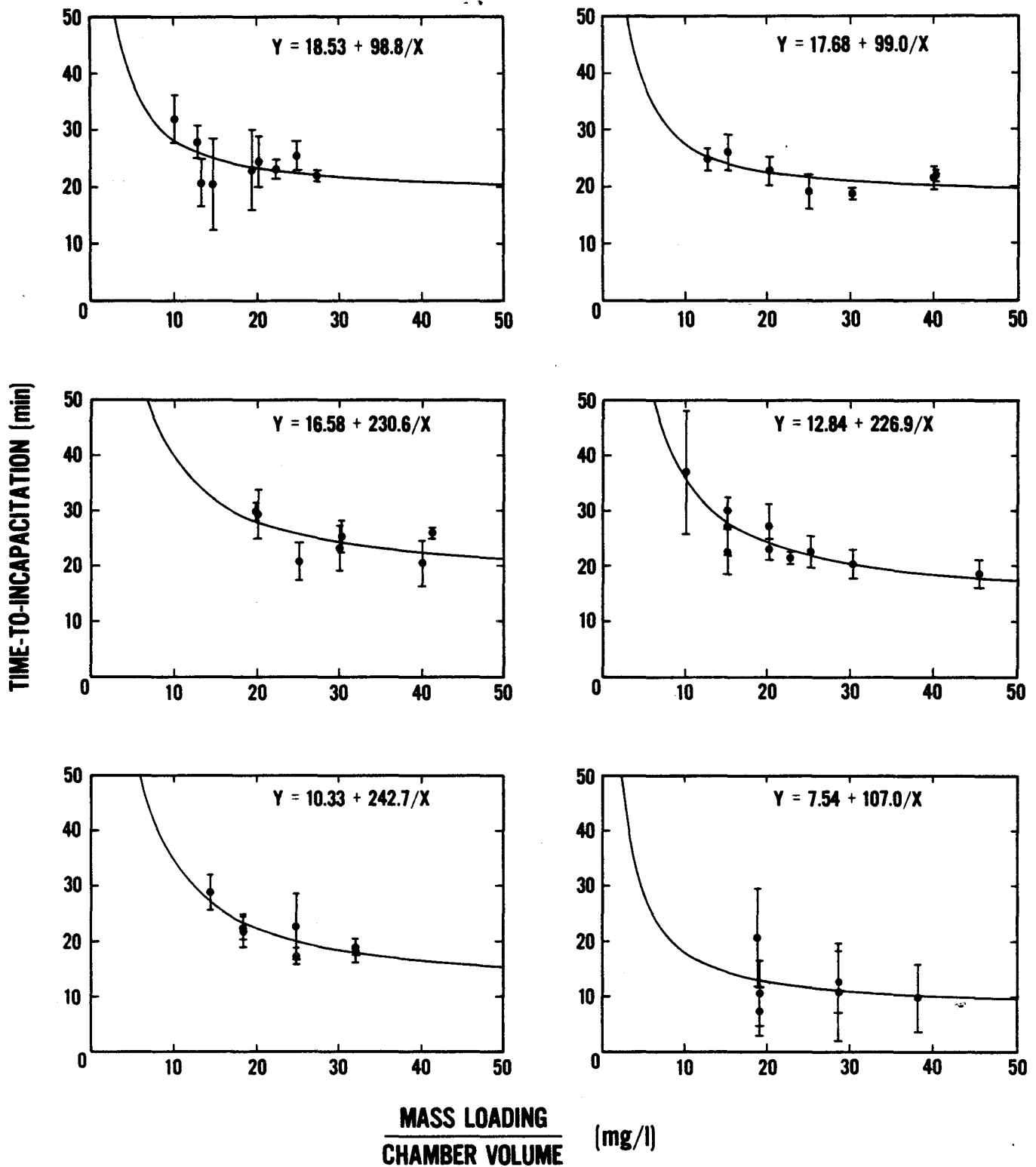

Figure 20. Time-to-incapacitation vs mass loading/chamber volume hyperbolas for Douglas fir in the non-flaming mode from six laboratories. (Symbols refer to the mean and standard deviation of the times-to-incapacitation of the 6 animals tested at each mass loading.)

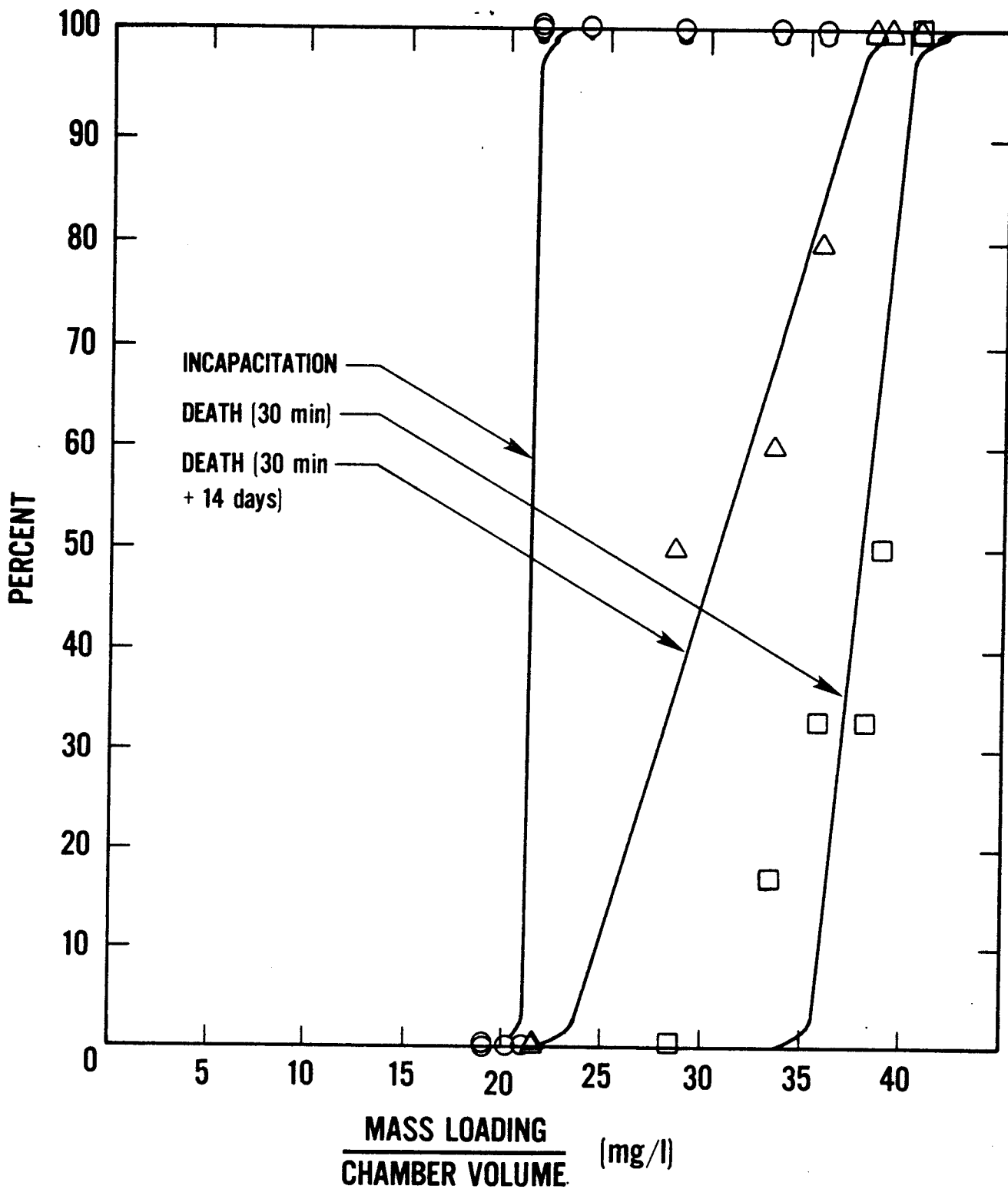

Figure 21. Concentration-response curves resulting from animal incapacitation, death within exposure (30 min) and death both within and post-exposure (30 min + 14 days) from the thermal decomposition of wool in the flaming mode.

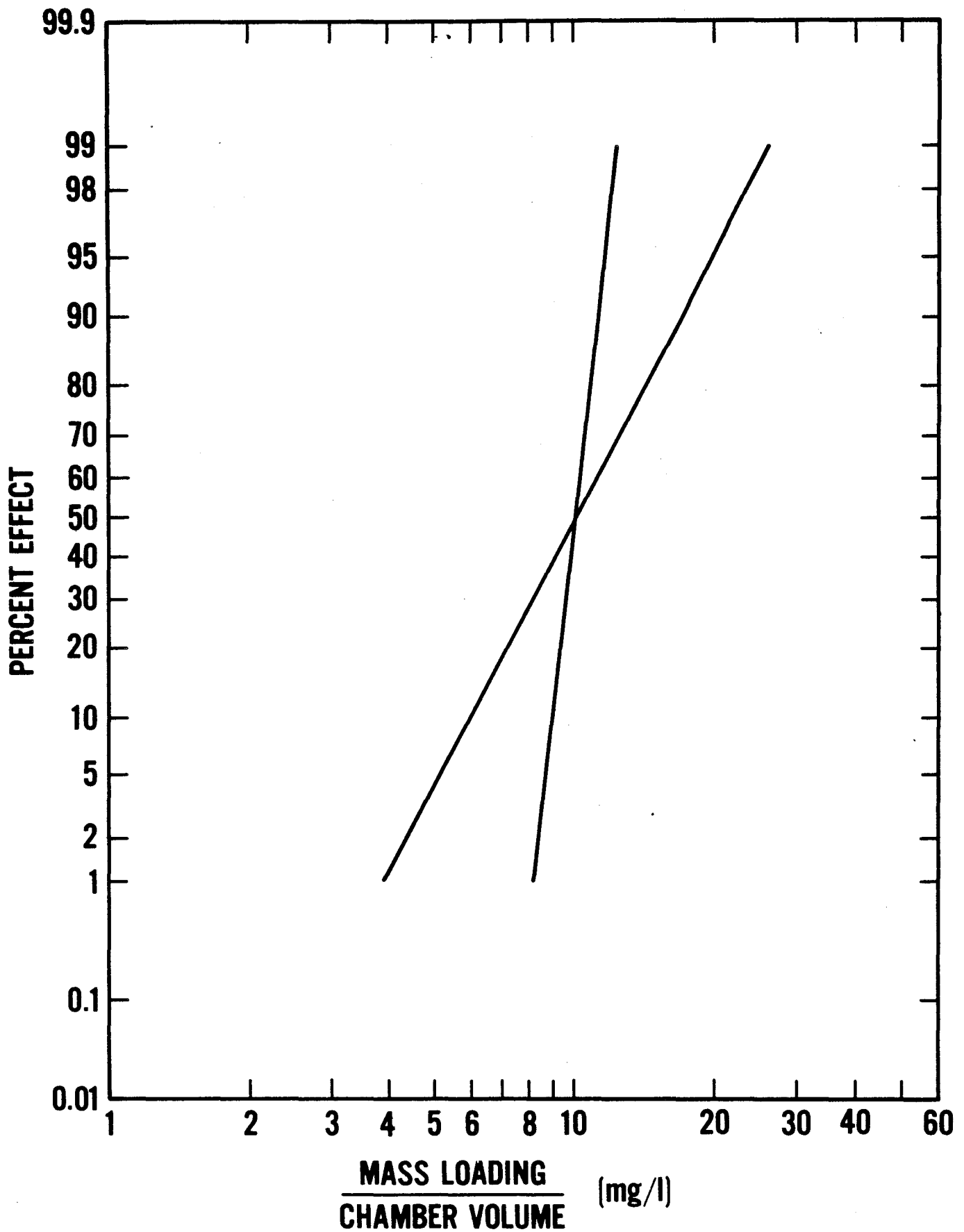

Figure 22. Concentration-response curves depicting importance of slope information, i.e., LC₅₀ data are the same, but the effective concentration range differs.

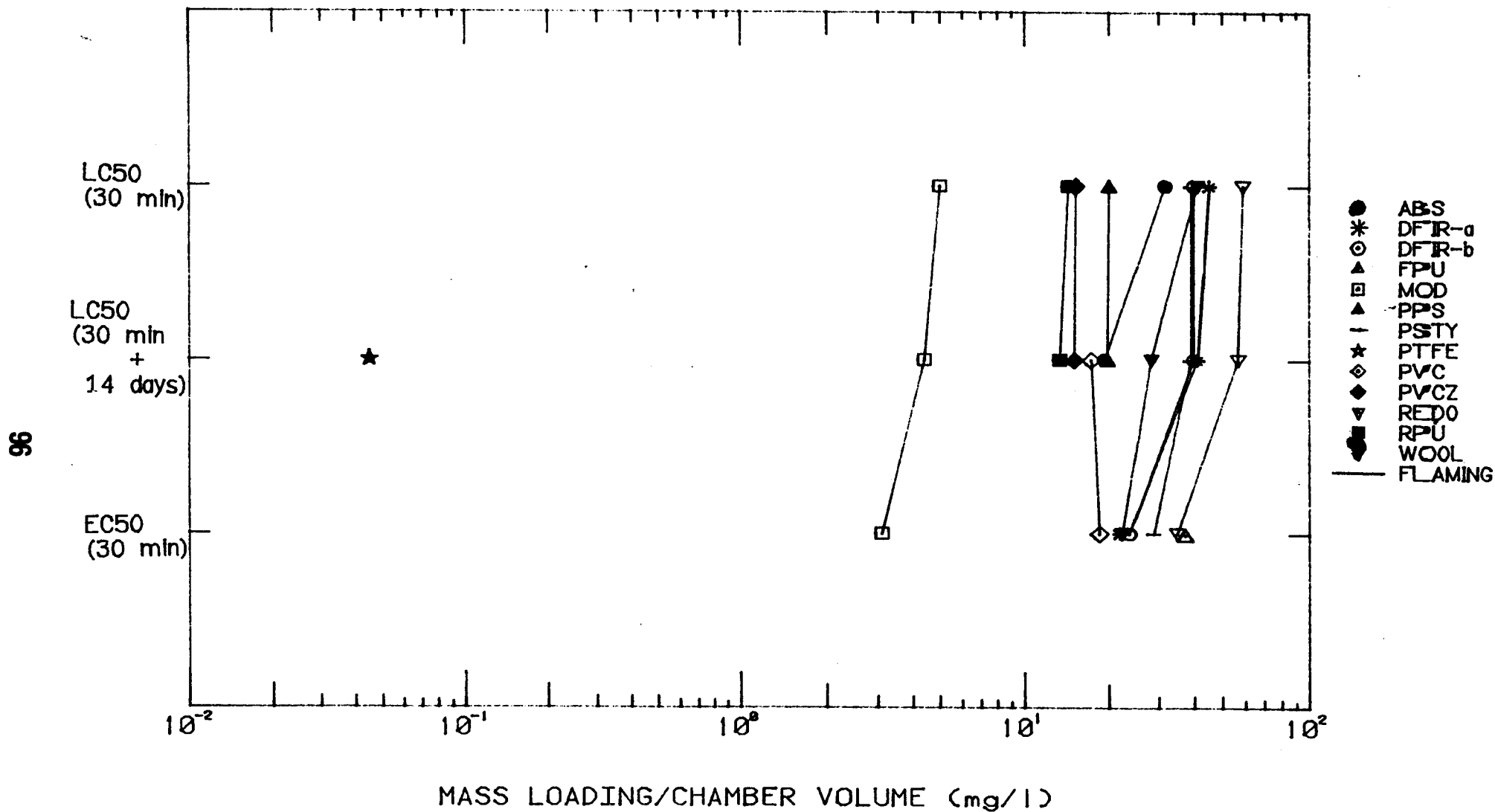

Figure 23. Comparison of materials by their EC₅₀, LC₅₀ (30 min) and LC₅₀ (30 min + 14 days) after flaming decomposition (NBS data). (Symbols referring to the same material are connected by lines for easier identification and not to imply a mathematical functional relationship.)

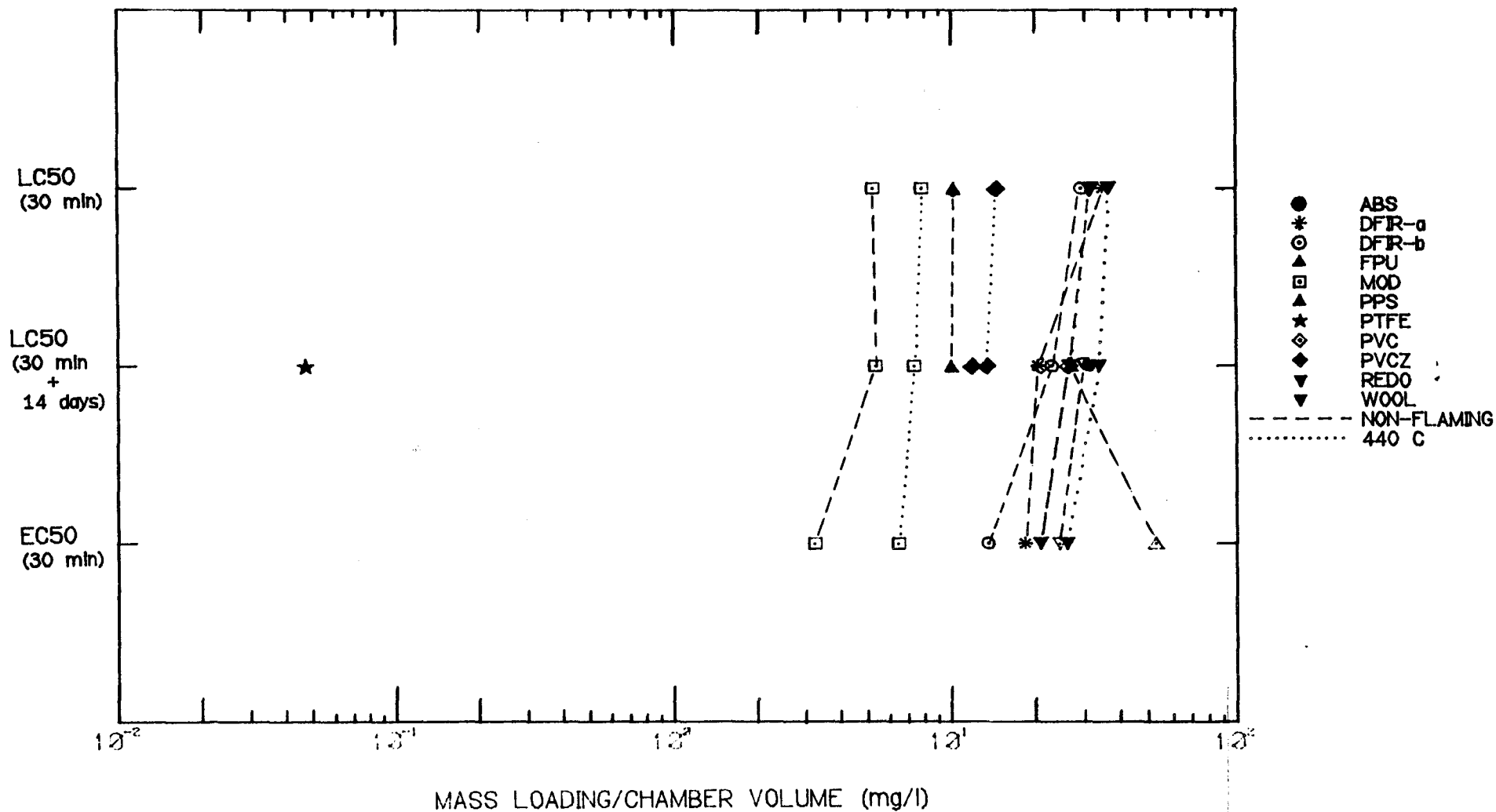

Figure 24. Comparison of materials by their EC50, LC50 (30 min) and LC50 (30 min + 14 days) after non-flaming decomposition (NBS data). (Symbols referring to the same material are connected by lines for easier identification and not to imply a mathematical functional relationship.)

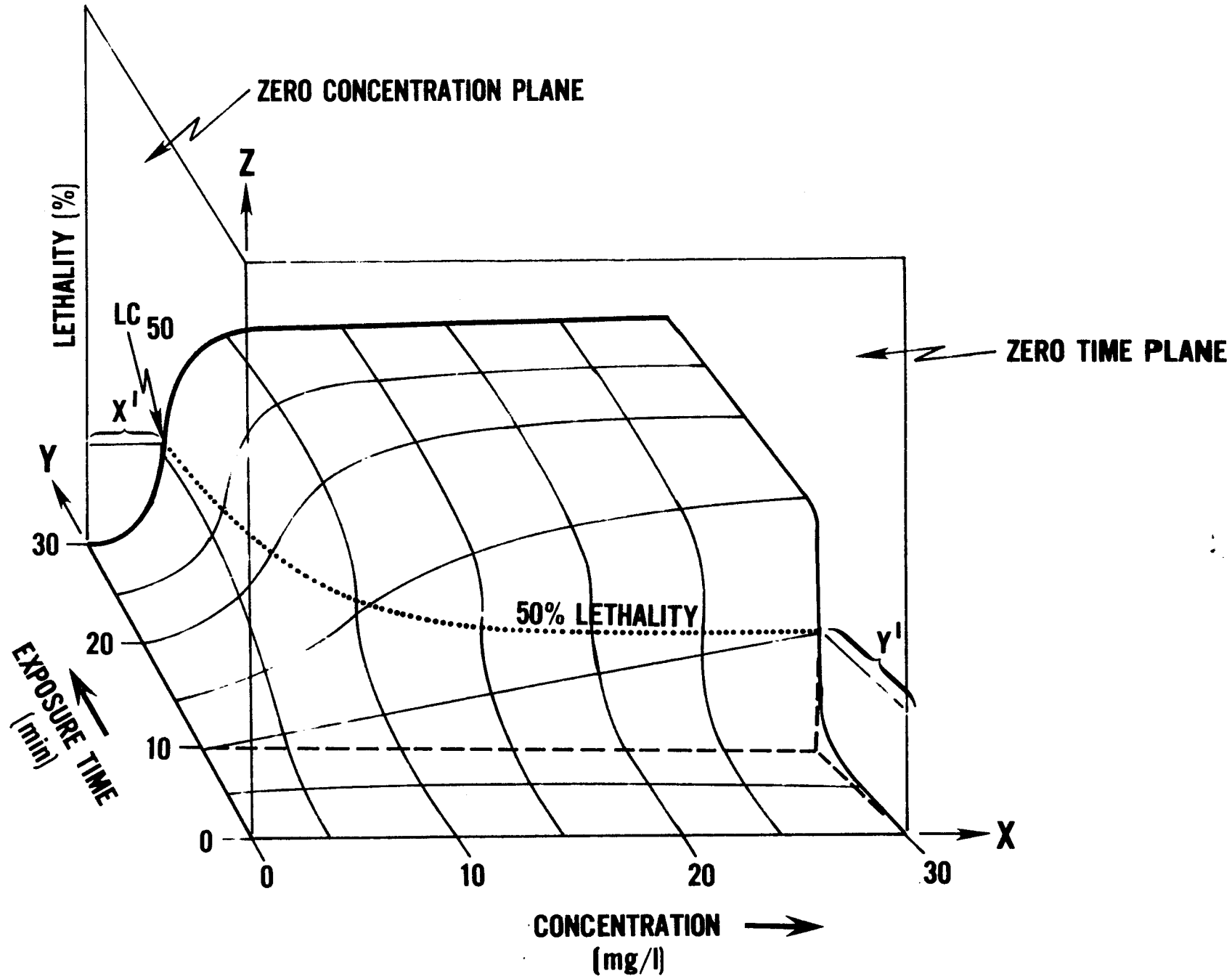

Figure 25. Three dimensional representation of the relationship between concentration, time, and lethality. (Figure modified after Packham and Hartzell (24).

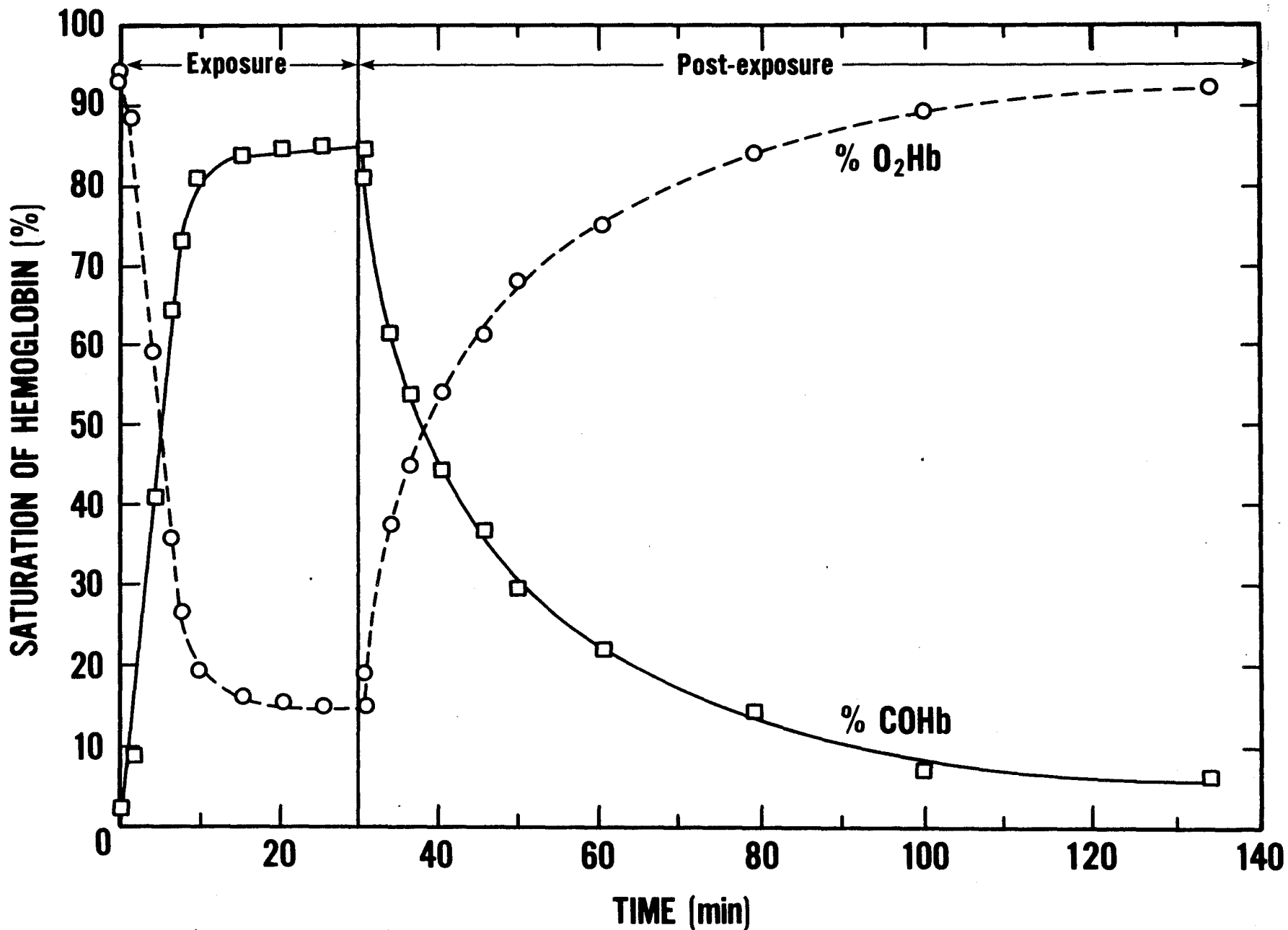

Figure 26. Within- and post-exposure changes in carboxyhemoglobin and oxyhemoglobin in live cannulated rats after a 30 minute exposure to an average concentration of 4100 ppm of carbon monoxide.

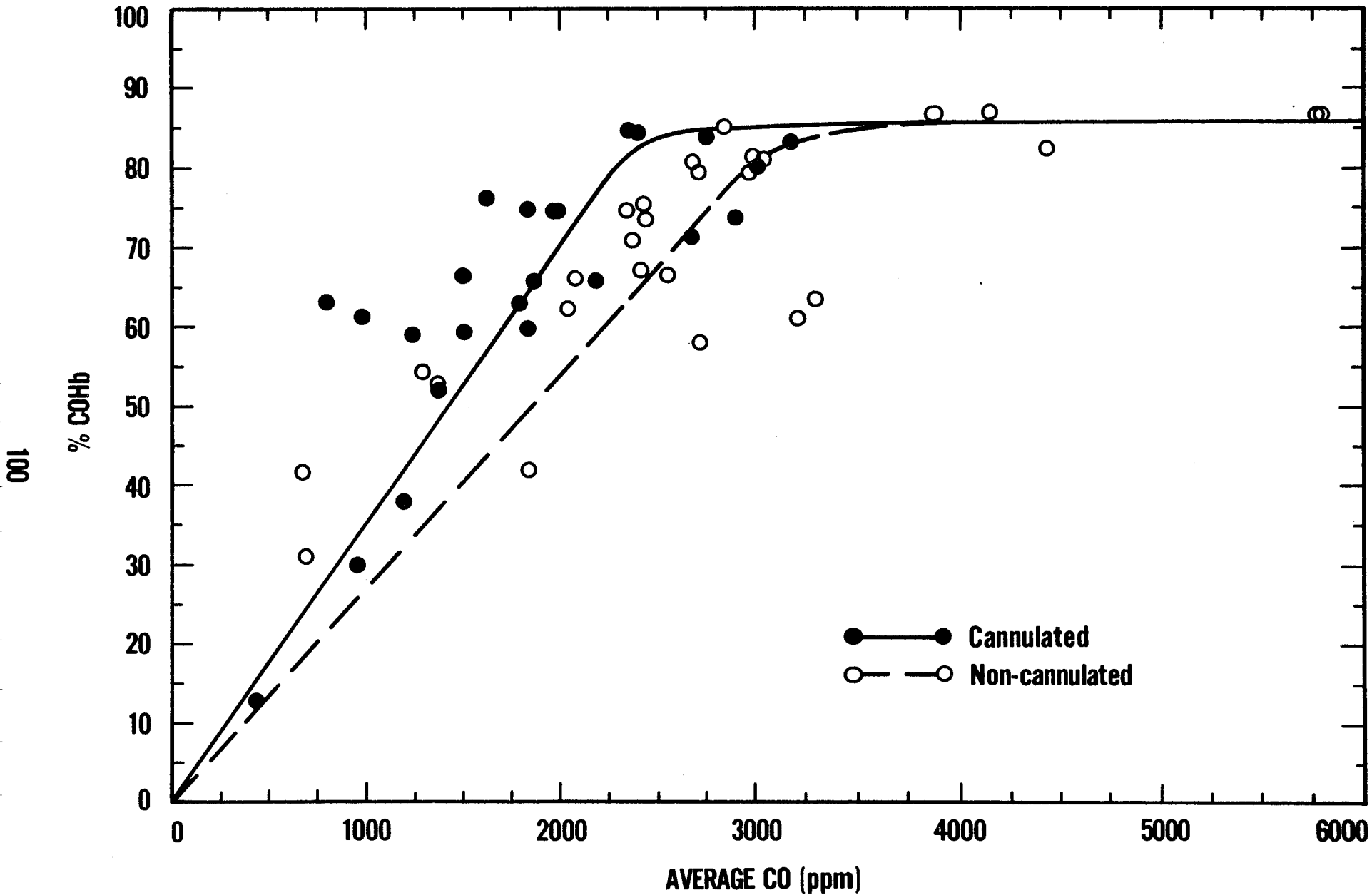

Figure 27. Effect of blood sampling before end of exposure (cannulated animals) and after exposure (non-cannulated animals). Results from Douglas fir in the non-flaming mode from seven laboratories.

DETERMINATION OF COHb AT EC50 AND LC50

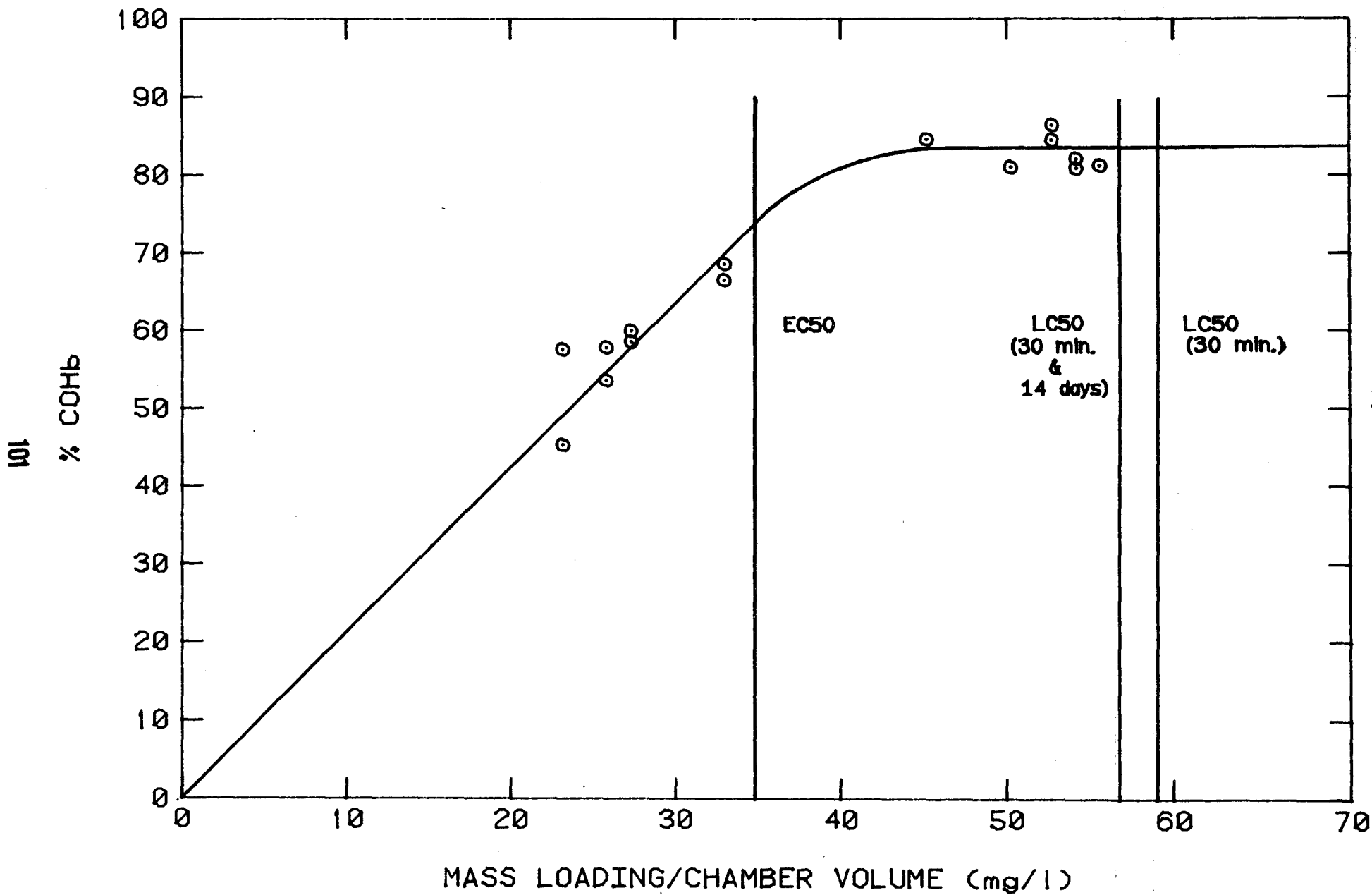

Figure 28. Determination of percent carboxyhemoglobin at EC50, LC50 (30 min), and LC50 (30 min + 14 days) from blood values obtained at various mass loadings. (NBS data from flaming red oak.)

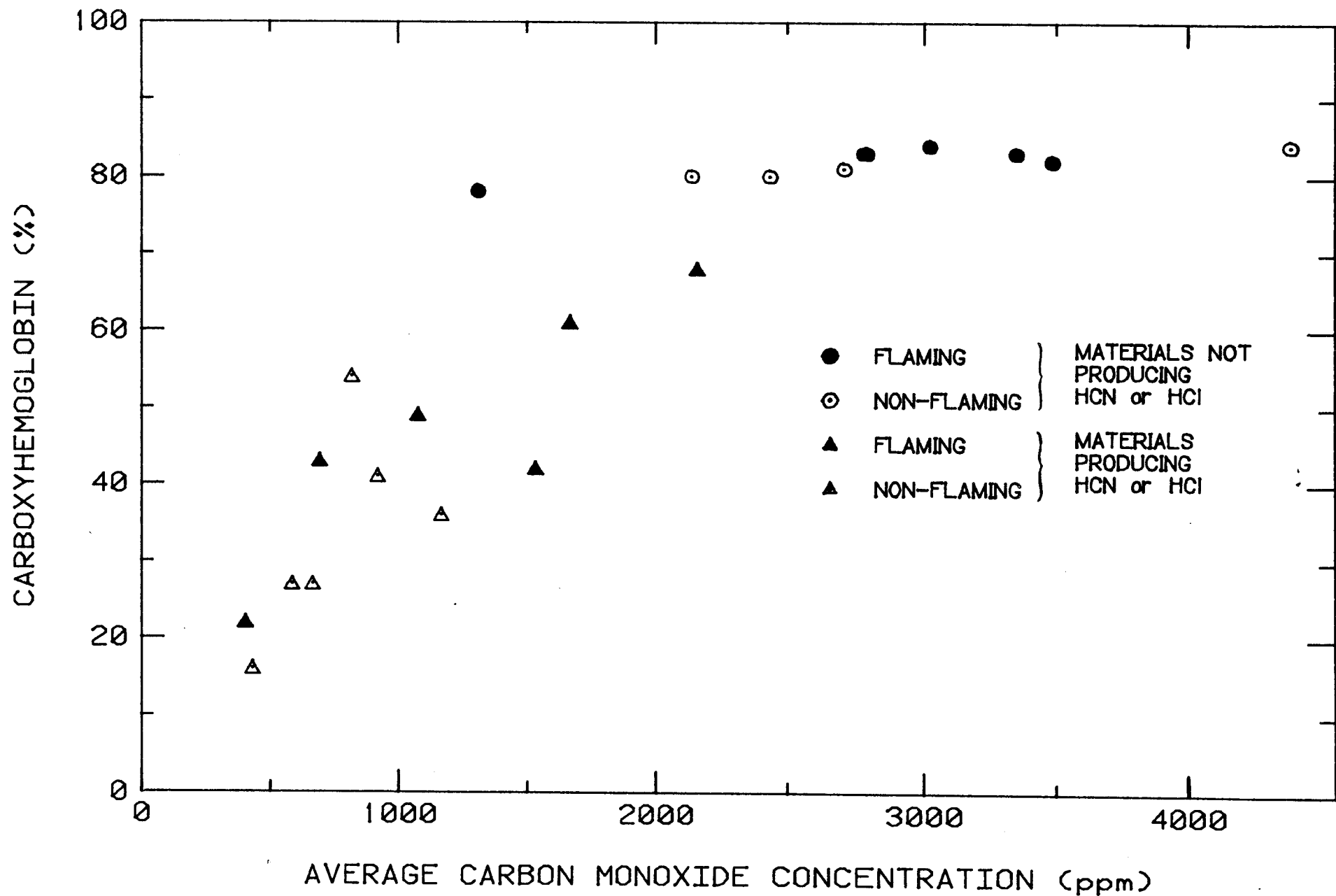

Figure 29. Relationship between carboxyhemoglobin and carbon monoxide at the LC₅₀ (30 minutes + 14 days) for eleven materials (NBS data).

TABLE 1

Participants of the Ad Hoc Working Group

<u>Organization</u>	<u>Representatives</u>
Armstrong World Industries, Inc.	H. J. Roux
BETR Sciences Incorporated	S. Packham
The B. F. Goodrich Co.	M. M. O'Mara
Carnegie-Mellon University	S. Gad J. Dorko
Consumer Product Safety Commission (U.S. Government)	J. McLaughlin R. Orzel S. Womble
Dow Chemical Co.	W. Potts
E.I. duPont de Nemours & Co.	B. Burgess R. W. Hartgrove, Jr. C. Lapin C. Reinhardt S. Williams
Federal Aviation Administration (U.S. Government)	C. Crane D. Sanders E. Podolak
Harvard University	D. Dressler R. Sprenger
The Johns Hopkins University	Z. Annau P. McGuire
Johnson Space Center (U.S. Government)	H. Kaplan
Monsanto Co.	W. Fitzgerald
National Aeronautics and Space Administration (U.S. Government)	T. Halstead
National Bureau of Standards (U.S. Government)	M. Birky A. Fowell B. Levin M. Paabo

Table 1 (continued)

<u>Organization</u>	<u>Representatives</u>
Owens-Corning Fiberglas Corporation	J. Hadley J. Prusaczyk D. Thomson
Southwest Research Institute	G. Hartzell
Weyerhaeuser Co.	R. R. McNeil H. Stacy
University of Arizona	J. W. Clayton
University of Michigan	R. Hartung
University of Pittsburgh	Y. Alarie R. Anderson
University of Utah	D. Farrar

TABLE 2

List of Materials

Material	Description	Abbreviations
Acrylonitrile butadiene styrene	pellets	ABS
Douglas fir	slabs 10" x 10" x 1"	DFIR
Flexible polyurethane ^{P,a}	flexible foam	FPU
Modacrylic	knit fabric	MOD
Polyphenylsulfone	pellets	PPS
Polystyrene ^{P,b}	rigid foam	PSTY
Polytetrafluorethylene	resin	PTFE
Poly(vinyl chloride)	pellets	PVC
Poly(vinyl chloride) with zinc ferrocyanide	pellets	PVCZ
Red oak	flooring boards	REDO
Rigid polyurethane ^{P,c}	rigid foam	RPU
Wool	unbleached unwoven fibers	WOOL

p: PRC material was obtained from the Products Research Committee, Office of Standard Reference Materials, National Bureau of Standards, Washington, D.C. 20234 [29]. a: GM-21; b: GM-51; c: GM-30.

It is important to note that the results shown in tables 21, 22, and 23 pertain to the particular samples tested during this study. The materials used were selected to represent a wide range of properties. No attempt was made to provide statistically valid samples of a given material. Therefore the results should not be used to judge any particular class of material.

TABLE 3*

Interlaboratory Evaluation of Douglas Fir

<u>Laboratory</u>	LC ₅₀ (30 minutes + 14 days)	
	<u>Non-flaming</u>	<u>Flaming</u>
1	16.7(14.5 - 19.3) ^c	35.8(28.6 - 44.9)
2	27.6(22.9 - 33.3)	45.3(39.0 - 52.7)
3	26.8(21.3 - 33.7)	28.0 ^d
4	24.0(19.9 - 29.0)	29.6(22.7 - 38.6)
5	25.9(20.0 - 33.5)	38.4(35.2 - 41.9)
NBS ^a	20.4(16.4 - 25.3)	41.0(33.0 - 50.9)
NBS ^b	22.8(20.2 - 25.8)	39.8(38.2 - 41.4)
8	18.5(17.3 - 19.8)	29.8(23.9 - 37.1)
Mean \pm 95% confidence limits ^e	22.8(13.4 - 32.2)	36.0(21.1-50.8)

a: NBS small furnace

b: NBS large furnace

c: mg/l (95% confidence limits)

d: estimated

e: eight data sets included

*In this table and subsequent tables, the numbers quoted are as calculated from the data provided by various laboratories. The 95% confidence limits reflect only statistical variations.

TABLE 4

Modifications of the Experimental Procedure

Laboratory	Furnace			Exposure Chamber		Gas Samp. Rate (liter/ min.)	Animal Information							
	Type	Dia. (cm)	Depth (cm)	Vol. (ml)	L x W x H (cm)		Volume (liters)	Strain	Age (months)	#Exposed Test	Pre-exposure Observation (days)	Cannulation (#)	Shock Current (ma)	Restrainer Material
1	Potts	5.49	12.7	300	121.9 x 35.6 x 45.7	198.2	0.75	Sprague-Dawley	-	6	7	No	5	plastic
2	Potts	5.0	12.0	236	121.9 x 35.6 x 45.7	200.6	0.5	Fischer 344	4	6	14	No ^c	3	aluminum
3	Potts	5.5	12.0	285	130 x 35.4 x 42	193	0.15	Long Evans	3-4	6	14	Yes (3) ^d	1-3	plastic
4	Potts	5.6	12.5	308	120 x 33.5 x 44	176.9	1	Sprague-Dawley	2	6	10	No ^e	1-10	plastic
5.	Potts	5.5	11.7	278	119.4 x 35.5 x 43.2	182	-	Sprague-Dawley	2-3	6	5-10	Sometimes (1-2)	4.6	aluminum
6a	Potts	6.1	12.4	362	121.9 x 35.6 x 45.8	199	2	Fischer 344	2	6	>10	Yes (2) ^f	12.5-13.5	aluminum
6b	Therm- craft	9.0	15.0	954	119.4 x 35.6 x 45.7	194	2	Fischer 344	2	6	>10	Yes (2) ^f	12.5-13.5	aluminum
b	Other	10.0	1.0	79	75 x 60.8 x 44.8 33.6 x 28.4 x 45.3 12.8 x 7.5 (diam.)	249	every 5 min.	Sprague-Dawley	2	3	8	No	8	plastic

a. NBS Smaller furnace

b. NBS larger furnace

c. Blood samples via cardiac puncture, open chest.

d. Cannulated animals kept through 14 day post-exposure period.

e. Blood samples via cardiac puncture.

f. Cannulated animals sacrificed following exposure.

TABLE 5
 Toxicity of Modacrylic at Different Temperatures

Mode	Temperature(°C)	LC ₅₀ , 30 minutes + 14 days ^a mg/l (95% confidence limits)
Flaming	760 - 775	7.1(6.4 - 7.9)
Non-Flaming	710 - 720	7.8(6.3 - 9.7)
	445 - 460	10.0(6.9 - 14.4)
	390 - 400	13.6(10.7 - 17.3)
	295 - 305	21.8(18.4 - 25.8)
	250 - 260	~23.8[17.0 - 28.3 ¹²] ^b
	200	>22.6 ¹

a: data from laboratory 4.

b: for explanation of superscripts, see legend to table 16.

TABLE 6

Single Versus Multiple Pieces of Douglas Fir^a

Mass Loaded Chamber Vol. (mg/l)	Number Pieces	CO (ppm-min)	Incapacitation 30 min (%)	Lethality		Time to Incapacitation ^b
				30 min (%)	30 min + 14 days (%)	
20.25	1	50100	60	0	50	29:23 ± 4:27
20.05	2	68300	60	0	50	29:45 ± 1:38
30.35	1	70400	100	16.7	100	25:16 ± 2:57
30.15	3	71800	100	16.7	80	23:09 ± 4:08
41.41	1	-	100	50	100	25:55 ± 1:01
40.20	4	71100	100	83.3	100	20:26 ± 4:10

a: NBS data from non-flaming mode, 440°C.

b: Mean time (min:sec) ± standard deviation

TABLE 7

Maximum Chamber Temperatures During Animal Exposures*

Material	Laboratory #	Flaming (°C)	Non-flaming (°C)	440°C
ABS	5	33	29	26
	6b	40	32	
DFIR	2	40		
	3	32		
	4	41	35	
	6a	42	31	
	6b	37	41	
FPU	6a	47	30	
	6b	64	33	
MOD	2		37	
	4	40	38	34
	5	40	36	31
	6a	37	38	28
	6b			33
PPS	2	43	39	30
	4		49	34
	5	31	32	24
	6b	53	39	
PSTY	2	45	30	
	6a	65	33	
	6b	56	36	
PTFE	4			38
PVC	6b	37	35	35
PVCZ	2	43	40	30
	6b	37	40	33
REDO	5	34	30	
	6a	37	29	
	6b	46		
RPU	4	29		
	6b	40	31	
WOOL	2	50	34	31
	6a	109	36	
	6b			36

*Temperatures were taken at the level of the animals' noses.

a: NBS small furnace

b: NBS large furnace

c: For abbreviations of materials, see table 2.

TABLE 8

Material	NBS Carbon Monoxide Production Per Unit				<u>Mass Loading*</u> <u>Chamber Volume</u>	
	Flaming		Non-Flaming		440°C	
	Mean	Std. Dev.	Mean	Std. Dev.	Mean	Std. Dev.
	<u>ppm</u> mg/l		<u>ppm</u> mg/l		<u>ppm</u> mg/l	
ABS (b)	75	16	22	2.5	-	
DFIR (a)	76	6.7	110	19	-	
(b)	83	7.2	118	21	-	
FPU (a)	19	1.8	39	18	-	
(b)	26	1.5	30	19	-	
MOD (a)	77	34	82	2.4	35	1.8
(b)	-		-		27	10
PPS (b)	183	17	470	26	-	
PSTY (b)	34	3.6	1.8	0.3	-	
PVC (b)	54	19	32	5.2	14	3.7
PVCZ (b)	146	12	101	10	35	6.0
REDO (a)	57	9.4	83	7.5	-	
(b)	37	2.4	-		-	
RPU (b)	127	12	45	8.8	-	
WOOL (a)	25	4.1	39	7.8	-	
(b)	25	4.3			12	1.9

*Mean of Average gas concentration (ppm) for each 30 minute exposure
Mass loading/chamber volume (mg/l)

(a) small furnace

(b) large furnace

TABLE 9

NBS Carbon Dioxide Production Per Unit $\frac{\text{Mass Loading}^*}{\text{Chamber Volume}}$

Material	Flaming		Non-Flaming		440°C	
	Mean	Std. Dev.	Mean	Std. Dev.	Mean	Std. Dev.
	$\frac{\text{ppm}}{\text{mg/l}}$		$\frac{\text{ppm}}{\text{mg/l}}$		$\frac{\text{ppm}}{\text{mg/l}}$	
ABS (b)	550	58	170	15	-	
DFIR (a)	690	83	260	88	-	
(b)	930	71	300	70	-	
FPU (a)	-		115	53	-	
(b)	1200	17	130	27	-	
MOD (a)	900	400	1000	240	450	160
(b)	-		-		490	78
PPS (b)	1100	59	540	120	-	
PSTY (b)	500	84	52	5.8	-	
PVC (b)	320	98	230	87	130	21
PVCZ (b)	650	79	470	20	370	30
REDO (a)	650	62	240	43	-	
(b)	780	11	-		-	
RPU (b)	900	82	230	60	-	
WOOL (a)	-		280	90	-	
(b)	-		-		160	19

*Mean of $\frac{\text{Average gas concentration (ppm) for each 30 minute exposure}}{\text{Mass loading/chamber volume (mg/l)}}$

(a) small furnace

(b) large furnace

TABLE 10

NBS Hydrogen Cyanide Production Per Unit $\frac{\text{Mass Loading}^*}{\text{Chamber Volume}}$

Material	Flaming		Non-Flaming		440°C	
	Mean	Std. Dev.	Mean	Std. Dev.	Mean	Std. Dev.
	$\frac{\text{ppm}}{\text{mg/l}}$		$\frac{\text{ppm}}{\text{mg/l}}$		$\frac{\text{ppm}}{\text{mg/l}}$	
ABS (b)	6.4	2.6	5.3	0.5	-	
FPU (a+b)	0.6	0.2	0.4	0.2	-	
MOD (a)	41	5.3	47	4.8	-	
(b)	-		-		27	4.8
PVCZ (b)	7.6	1.0	13	2.2	13	0.8
RPU (b)	9.5	1.8	1.2	1.0	-	
WOOL (a)	4.1	1.4	12	4.7	-	
(b)	-		-		7.3	

*Mean of $\frac{\text{Average gas concentration (ppm) for each 30 minute exposure}}{\text{Mass loading/chamber volume (mg/l)}}$

(a) small furnace

(b) large furnace

TABLE 11

Minimum Average Oxygen Concentrations

Material	Percent Oxygen					
	Flaming		Non-flaming		440°C	
	a	b	a	b	a	b
ABS		18.9		20.1		
DFIR	17.8	16.3	19.9	19.2		
FPU	17.4	14.2	19.3	19.9		
MOD	18.7		18.5		20.3	19.9
PPS		17.7		19.7		
PSTY	18.8	17.9	20.7	20.2		
PVC		19.2		19.3		19.7
PVCZ		19.3		19.9		19.5
REDO	17.2	16.8	19.6			
RPU		18.8		19.7		
WOOL	16.2	17.5	19.3			19.8

a: NBS small furnace

b: NBS large furnace

TABLE 12

Incapacitation Times After Exposure to Non-Flaming PVC

Mass Loading Chamber Volume (mg/l)	Test Duration (min)	Animal Number	Incapacitation Time	
			Actual (min:sec)	Mean \pm Standard Deviation (min:sec)
30.9	90	1	9:15	44:59 \pm 32:31
		2	19:45	
		3	21:00	
		4	62:45	
		5	71:50	
		6	86:20	
46.4	60	1	12:15	36:39 \pm 12:41
		2	33:50	
		3	40:40	
		4	42:30	
		5	44:40	
		6	46:00	

TABLE 13

Constants for Time-Concentration Hyperbolas ($y = Q + R/x$)

Material	Laboratory	Flaming		Non-flaming		440°C	
		Q	R	Q	R	Q	R
ABS	1	3.2	188.0	-6.1	738.0	-13.8	1011.5
	5	12.6	56.7	0.7	492.5	d	
DFIR	1	13.3	231.4	12.8	226.9	H	
	2	5.0	389.2	17.7	99.0	H	
	3	7.2	265.8	7.5	107.0	H	
	6a	13.2	317.3	16.6	230.6	H	
	6b	13.8	246.2	18.5	98.7	H	
	8	9.3	230.3	10.3	242.7	H	
FPU	6a,b	-42.9	2739.0	G		H	
MOD	2	N.D.		-7.7	161.3	N.D.	
	5	-2.3	79.8	-0.5	62.9	4.5	78.4
	6	-2.8 ^a	82.9 ^a	-18.6 ^a	149.9 ^a	-3.4 ^{a,b}	157.4 ^{a,b}
PPS	2	10.5	259.8	7.4	212.0	C	
	4	e		17.11	205.9	C	
	5	12.1	92.5	9.2	99.8	N.D.	
PSTY	2	-25.3	1689.4	G		H	
	6b	-6.4	649.2	d		H	
PTFE	1	6.5	27.0	4.9	16.7	d	
PVC	3	e		2.8	161.4	C	
PVCZ	1	-3.8	347.9	2.1	78.6	6.5	130.0
	2	15.0	1.9	-51.7	888.9	d	
REDO	5	9.2	441.5	16.8	172.5	H	
	6	12.0 ^{a,b}	385.3 ^{a,b}	5.8 ^a	480.0 ^a	H	
	8	5.0	856.6	12.0	299.2	H	
RPU	8	4.5	139.3	-3.9	940.6	G	
WOOL	2	2.2	586.0	4.4	272.6	d	
	3	-10.9	517.0	e		e	
	6	5.7 ^a	409.9 ^a	-12.0 ^a	867.9 ^a	11.2 ^b	332.3 ^b
	8	11.0	497.1	-9.5	891.1	-61.9	2595.9

a: NBS small furnace

b: NBS large furnace

C: No data points

d: One data point

e: Two data points

G: No incapacitation

N.D. Not determined

H: Non-flaming temperature within 50°C of 440°C

TABLE 14
EC₅₀ Values¹⁹ in mg/l

Material	Laboratory	Flaming	Non-flaming	440°C
ABS	1	10.6(7.4 - 15.2) ^{c*}	~21.0[15.1 ¹ - 25.2 ¹²] ^d	~20.2[15.1 ¹ - 25.2 ¹³]
	3	6.0(4.1 - 8.9)	5.8(2.8 - 8.4)	9.0(4.7 - 17.3)
	5	~17.0[15.0 ⁷ - 20.0 ¹³]	~23.0[18.5 ¹ - 27.5 ¹³]	< 37.6 ¹³
DFIR	1	20.0(16.4 - 24.3)	15.0(12.3 - 18.2)	H
	2	18.4(14.0 - 24.1)	10.1(7.2 - 14.2)	H
	3	~14.5[10.0 ¹ - 19.1 ¹³]	5.6(3.1 - 9.9)	H
	4	N.D.	22.0(13.2 - 36.7)	H
	5	14.0(10.5 - 18.6)	19.2(14.3 - 25.8)	H
	6a	21.8(15.5 - 30.7) ¹⁷	18.3(14.5 - 23.0)	H
	6b	~23.5[23.0 ¹ - 24.0 ¹³]	13.5(12.9 - 14.2)	H
	8	~20.9 ^{3,13}	14.7(13.3 - 16.2)	H
FPU	3	9.6(4.1 - 22.1)	7.0(3.6 - 13.6)	H
	4	~49.5 ^{10,15}	20.2(8.6 - 47.3)	H
	6a, b	37.5(35.8 - 39.3)	53.0(40.1 - 69.9)	H
MOD	2	N.D.	2.7(2.1 - 3.4)	N.D.
	5	~2.8[2.0 ¹ - 3.0 ⁹⁺]	~3.0[2.0 ¹ - 4.0 ¹³]	~5.0[4.0 ¹ - 6.0 ¹³]
	6	3.1(2.2 - 4.3) ^{a,17}	3.2(2.8 - 3.7) ^a	6.4(5.8 - 7.0) ^{a,b}
PPS	2	< 15 ¹²	8.8(6.8 - 11.2)	> 19.9 ¹
	4	21.8(12.9 - 36.7)	19.0(10.2 - 35.3)	N.D.
	5	< 10 ¹³	< 7.0 ¹³	> 40.0 ¹
PSTY	2	~30.0 ¹⁰	> 50.0 ¹	H
	6b	~28.7[27.5 ¹ - 30.4 ¹³]	> 40.0 ¹	H
PTFE	1	~0.80[0.063 - 1.514 ¹³]	0.68(0.31 - 1.49)	~15.2[15.1 ¹ - 25.2 ¹³]
	6a	> 0.25 ¹	> 5.03 ¹	N.D.
PVC	3	6.0(4.0 - 8.9)	~9.4 ^{10,16}	13.5(4.9 - 36.8)
	6b	~18.5[17.5 ⁵ - 19.8 ¹³]	> 30.0 ⁵	> 30.0 ⁵
PVCZ	1	11.8[10.1 ⁸ - 15.1 ¹³]	~5.4[5.1 ¹ - 10.1 ¹³]	7.6(4.5 - 12.7)
	2	13.2(11.3 - 15.4)	11.7(10.3 - 13.2)	~12.4 ^{10,15}
REDO	5	< 40.6 ¹³	< 25.0 ¹³	H
	6	34.8(31.1 - 39.0) ^{a,b}	~23.0[22.5 ¹ - 24.2 ¹³] ^a	H
	8	51.0(46.1 - 56.5)	~24.1 ^{3,13}	H
RPU	8	8.9(5.1 - 15.6)	~29.3 ⁶ [29.3 ¹ - 35.1 ¹³]	> 35.2 ¹
WOOL	2	23.8(16.0 - 35.3)	~17.0[15.0 ⁵ - 20.0 ¹³]	> 27.0 ⁷
	3	~17.2[9.7 ⁸ - 19.0 ¹³]	6.8(4.2 - 11.1)	~23.3[19.3 ⁴ - 30.1 ¹³]
	6	~22.3[22.1 ¹ - 22.6 ¹³] ^a	19.7(16.2 - 24.0) ^a	24.5(23.0 - 26.1) ^b
	8	< 45.0 ¹³	24.0(20.3 - 28.3)	~29.3 ⁶ [29.3 ¹ - 35.2 ¹³]

*For explanation of superscript letters and numbers, see legend to table 16.

TABLE 15
Slopes of EC₅₀ Concentration-Response Curves^{19,20}

Material	Laboratory	Flaming	Non-flaming	440°C
ABS	1	1.34(1.09 - 1.64)	E	E
	3	1.63(1.02 - 2.59)	2.00(1.15 - 3.47)	2.71(0.78 - 9.38)
	5	E	E	D
DFIR	1	1.35(1.08 - 1.70)	1.58(1.26 - 1.98)	H
	2	1.50(0.89 - 2.52)	1.41(1.16 - 2.29)	H
	3	E	2.80(1.09 - 7.18)	H
	4	N.D.	2.09(0.41 - 10.78)	H
	5	1.43(1.07 - 1.91)	1.68(1.12 - 2.52)	H
	6a	1.13(0.86 - 1.48) ^{17*}	1.45(1.11 - 1.89)	H
	6b	E	1.09(1.01 - 1.17)	H
	8	E	1.09(0.98 - 1.21)	H
FPU	3	4.40(0.71 - 27.1)	2.76(1.26 - 6.03)	H
	4	E	7.32(0.94 - 56.8)	H
	6a,b	1.07(1.04 - 1.11)	1.73(1.07 - 2.79)	H
MOD	2	N.D.	1.40(1.11 - 1.77)	N.D.
	4	N.D.	N.D.	N.D.
	5	E	E	E
	6	1.25(0.69 - 2.28)	1.28(1.08 - 1.51)	1.20(1.03 - 1.41)
PPS	2	D	1.37(1.03 - 1.82)	C
	4	2.22(1.00 - 4.94)	2.59(1.58 - 4.23)	N.D.
	5	D	D	C
PSTY	2	E	C	H
	6b	E	C	H
PTFE	1	E	3.31(0.59 - 18.71)	E
	6a	C	C	N.D.
PVC	3	1.65(1.24 - 2.20)	E	5.90(0.29 - 120.59)
	6b	E	C	C
PVCZ	1	E	E	2.49(0.60 - 10.46)
	2	1.35(1.08 - 1.68)	1.28(1.01 - 1.61)	E
REDO	5	D	D	H
	6a,b	1.30(1.11 - 1.52)	E	H
	8	1.10(0.94 - 1.27)	E	H
RPU	8	2.18(0.28 - 17.21)	E	C
WOOL	2	1.41(0.33 - 5.93)	E	C
	3	E	2.13(0.96 - 4.74)	E
	6	E	1.35(1.08 - 1.69)	1.10(1.05 - 1.16)
	8	D	1.23(0.91 - 1.66)	E

*For explanation of superscript numbers and letters, see legend to table 18.

TABLE 16

LC₅₀ (30 minutes)¹⁹ Values in mg/l

Material	Laboratory	Flaming	Non-flaming	440°C
ABS	1	17.4(13.9-21.9) ^c	22.0(17.6-27.5)	30.3(26.5-34.7)
	3	15.6(13.2-18.4)	>38.0 ¹	>37.9 ¹
	5	20.8(18.9-22.9)	33.0(22.8-47.8)	>37.6 ⁴
	6b	22.1(20.0-24.4)	>32.5 ¹	N.D.
DFIR	1	35.0(29.0-42.2)	21.7(19.7-23.9)	H
	2	50.1(43.1-58.3)	42.9(38.9-47.3)	H
	3	~24.9[19.1 ¹ -28.8 ¹³] ^d	37.3(26.7-51.9)	H
	4	30.6(28.4-33.0)	24.9(19.4-31.9)	H
	5	38.4(33.2-44.4)	>46.5 ¹	H
	6a	45.0(38.5-52.6)	34.8(29.1-41.7)	H
	6b	39.8(38.2-41.4)	29.0(23.4-36.0)	H
	8	30.0(20.4-44.0)	20.5(15.8-26.6)	H
FPU	3	>38.0 ¹	>37.9 ¹	H
	4	>49.5 ¹	>50.9 ¹	H
	6a,b	>40.0 ⁵	>47.7 ⁵	H
MOD	2	N.D.	5.2(4.9-5.5)	N.D.
	4	7.3(6.6-8.1)	8.9(6.5-12.3)	10.4(7.1-15.3)
	5	5.0(3.5-7.0)	~7.5[4.8 ¹ -10.0 ¹³]	~5.6[4.0 ¹ -6.0 ⁹]
	6	5.0(4.2-5.9) ^a	5.2(4.4-6.2) ^a	7.8(6.9-8.8) ^{a,b}
PPS	2	50.0(30.2-82.9)	18.7(15.7-22.3)	>19.9 ¹
	4	~39.6[24.9 ¹ -39.6 ¹⁰]	32.2(27.6-37.6)	>9.9 ¹
	5	15.2(13.4-17.2)	11.0(8.4-14.3)	>40.0 ¹
	6b	20.0(16.8-23.8)	9.7(9.2-10.2)	N.D.
PSTY	2	53.5(41.8-68.5)	>50.0 ¹	H
	4	33.0(30.9-35.2)	>46.2 ¹	N.D.
	6b	38.9(37.9-39.9)	>40.0 ¹	H
PTFE	1	1.01(0.33-3.13)	0.90(0.46-1.75)	~21.9[5.1 ¹ -25.2 ⁹]
	4	2.60(1.15-5.89)	>0.99 ¹	~17.3[9.9 ⁵ -28.4 ¹³]
	6a	>0.251 ¹	>5.025 ¹	N.D.

TABLE 16 (Continued)

Material	Laboratory	Flaming	Non-flaming	440°C
PVC	3	>38.1 ¹	>28.5 ¹	>38.2 ¹
	6b	>30.0 ¹	>25.0 ⁵	>30.0 ¹
PVCZ	1	13.4(10.9-16.5)	9.6(7.3-12.7)	~13.0[10.1 ¹ -15.1 ¹²]
	2	15.4(13.4-17.6)	15.3(13.8-17.0)	>12.4 ¹
	6b	15.2(13.5-17.1) ¹⁷	>14.0 ⁸	13.9(13.2-14.6)
REDO	5	45.3(38.6-53.1)	40.0(35.8-44.7)	H
	6	59.0(54.5-63.9)	>45.0 ¹	H
	8	~65.0[60.3 ³ -72.3 ¹³]	35.2(29.9-41.4)	H
RPU	4	>38.4 ¹	>33.9 ¹	>39.6 ¹
	6b	14.3(13.4-15.3)	>39.6 ¹	N.D.
	8	14.4(11.7-17.8)	>35.1 ¹	>35.2 ¹
WOOL	2	>50.0 ¹	45.1(37.9-53.6)	>27.2 ¹
	3	~23.8[19.0 ¹ -28.6 ¹³]	15.8(13.4-18.6)	~27.4[19.3 ¹ -30.1 ¹¹]
	6	40.9(38.1-43.8) ^a	29.5(27.8-31.3) ^a	35.0(29.0-42.2) ^b
	8	58.3(50.7-67.0)	29.1(22.4-37.7)	~35.2[29.3 ¹ -35.2 ²]

a: NBS small furnace

b: NBS large furnace

c: (95% confidence limits)

d: Estimated EC₅₀ or LC₅₀ (values used to determine estimate)

H: 440°C is equal to or within 50°C of non-flaming temperatures

N.D. Not determined

1 0% affected

Superscripts 2-12 refer to number of animals affected/number of animals tested

2 1/2

3 1/3

4 1/5

5 1/6

6 2/3

7 2/5

8 2/6

9 3/5

9+ 4/5

10 3/6

11 4/6

12 5/6

13 100% affected

14 No data points between 0% effect and 100% effect

15 One data point only

16 One data point between 0% effect and 100% effect

17 Significantly heterogeneous data

18 Late post-exposure deaths not counted

19 Litchfield, J.T. and Wilcoxon, F., reference 26.

TABLE 17

LC₅₀ (30 minutes + 14 days) in mg/l (95% confidence limits)¹⁹

Material	Laboratory	Flaming	Non-flaming	440°C
ABS	1	15.0(12.3-18.3)	19.3(13.9-26.9)	30.0(26.5-34.0) ^{18*}
	3	15.6(13.2-18.4)	>38.4 ⁵	>38.0 ⁸
	5	20.8(15.9-27.2)	33.3(23.1-47.9)	>37.6 ⁴
	6b	19.3(16.7-22.3)	30.9(21.2-45.0)	N.D.
DFIR	1	35.8(28.6-44.9) ¹⁸	16.7(14.5-19.3)	H
	2	45.3(39.0-52.7)	27.6(22.9-33.3)	H
	3	~24[19.0 ¹ -29.0 ¹²] ¹⁶	26.8(21.3-33.7)	H
	4	29.6(22.7-38.6)	24.0(19.9-29.0)	H
	5	38.4(35.2-41.9)	25.9(20.0-33.5)	H
	6a	41.0(33.0-50.9)	20.4(16.4-25.3)	H
	6b	39.8(38.2-41.4)	22.8(20.2-25.8)	H
	8	29.8(23.9-37.1)	18.5(17.3-19.8)	H
FPU	3	>38.0 ¹	27.8(16.9-45.8)	H
	4	>49.5 ¹	40.0(31.2-51.3)	H
	6a&b	>40.0 ⁵	26.6(15.3-46.2) ¹⁷	H
MOD	2	N.D.	5.2(4.9-5.5)	N.D.
	4	7.1(6.4-7.9)	7.8(6.3-9.7)	10.0(6.9-14.4)
	5	4.7(3.2-6.9)	7.0(5.0-9.7)	~5.7[4 ¹ -6 ⁹] ¹⁶
	6	4.4(3.9-5.0) ^a	5.3(4.0-7.1) ^a	7.3(6.3-8.5) ^{a, b}
PPS	2	25.3(22.0-29.2)	18.7(15.2-23.0)	>19.9 ¹
	4	~36[24.9 ¹ -39.6 ¹¹] ¹⁶	32.2(27.7-37.5)	>9.89 ¹
	5	11.7(9.1-15.0)	10.7(8.4-13.6)	>40.0 ¹
	6b	19.8(14.8-26.5)	9.5(9.1-10.1)	N.D.
PSTY	2	53.5(41.4-69.1)	>50.0 ¹	H
	4	32.6(30.5-34.8)	>46.2 ¹	N.D.
	6b	38.9(37.9-39.9)	>40.0 ¹	H

TABLE 17 (Continued)

Material	Laboratory	Flaming	Non-flaming	440°C
PTFE	1	0.164(0.073-0.367)	0.125(0.083-0.188)	$\sim 15[5.0^1-25.0^{13}]^{14}$
	4	0.400(0.02-6.81)	0.235(0.05-1.20)	N.D.
	6a	0.045(0.039-0.054)	0.045(0.017-0.120)	N.D.
PVC	3	$\sim 15[10^1-19^{12}]^{16}$	$\sim 16[14^8-19^{13}]^{16}$	20.7(14.0-30.7)
	6b	17.3(14.8-20.2)	20.0(14.7-27.2)	25.0(20.2-31.0)
PVCZ	1	9.4(7.2-12.3)	7.6(5.5-10.5)	8.5(6.1-11.9)
	2	14.3(12.5-16.3)	13.3(11.5-15.4)	$>12.4^4$
	6b	$\sim 15[15.0^1-15.5^{13}]$	11.3(8.5-14.9)	12.8(12.1-13.6)
REDO	5	45.0(39.9-50.8)	25.0(18.7-35.5)	H
	6	56.8(51.6-62.5) ^{a,b}	30.3(26.0-35.4) ^a	H
	8	60.0(56.6-63.6)	35.0(24.5-50.1)	H
RPU	4	$>38.4^1$	$>34.0^1$	$>39.6^1$
	6b	13.3(12.2-14.5)	$>39.6^1$	N.D.
	8	11.3(7.6-16.8)	$>35.1^2$	$>35.2^1$
WOOL	2	42.8(36.6-50.1)	25.2(18.4-34.6)	$>27.2^1$
	3	$\sim 23[19^1-24^{13}]^{14}$	15.8(13.5-18.6)	$\sim 25[19^1-30^{11}]^{16}$
	6	28.2(23.0-34.5) ^a	25.1(22.3-28.3) ^a	32.1(30.2-34.1) ^b
	8	60.0(46.6-77.3)	28.5(23.5-34.6)	32.6(28.7-37.0)

*For explanation of superscript numbers and letters, see legend to Table 16.

TABLE 18

Slopes of LC₅₀, 30 Minutes,
(95% confidence limits of slope)^{19,20}

Material	Laboratory	Flaming	Non-flaming	440°C
ABS	1	1.63(1.36 - 1.96)	1.41(1.12 - 1.77)	1.18(1.05 - 1.33)
	3	1.23(1.08 - 1.39)	C	C
	5	1.14(1.11 - 1.18)	2.08(0.85 - 5.10)	C
	6b	1.24(1.11 - 1.37)	C	N.D.
DFIR	1	1.39(1.08 - 1.79)	1.17(1.08 - 1.26)	H
	2	1.25(1.01 - 1.55)	1.17(1.06 - 1.30)	H
	3	E	1.66(0.76 - 3.61)	H
	4	1.16(1.08 - 1.25)	2.01(1.19 - 3.40)	H
	5	1.29(1.11 - 1.50)	C	H
	6a	1.48(0.99 - 2.21)	1.43(1.06 - 1.93)	H
	6b	1.05(1.02 - 1.08)	1.39(0.71 - 2.72)	H
	8	1.83(0.19 - 17.54)	1.54(0.74 - 3.19)	H
FPU	3	C	C	H
	4	C	C	H
	6a,b	C	C	H
MOD	2	N.D.	1.11(1.01 - 1.21)	N.D.
	4	1.18(1.00 - 1.38)	1.62(1.13 - 2.33)	1.80(1.01 - 3.21)
	5	1.76(1.24 - 2.51)	E	E
	6	1.49(0.99 - 2.25) ^a	1.25(1.09 - 1.44) ^a	1.23(1.01 - 1.51) ^{a,b}
PPS	2	2.58(0.39 - 16.97)	1.30(1.05 - 1.61)	C
	4	E	1.21(0.97 - 1.51)	C
	5	1.19(1.09 - 1.30)	1.45(1.06 - 1.97)	C
	6b	1.24(0.88 - 1.75)	1.09(1.04 - 1.14)	N.D.
	PSTY	2	1.41(0.84 - 2.38)	C
	4	1.12(1.06 - 1.19)	C	N.D.
	6b	1.03(1.00 - 1.07)	C	H
PTFE	1	14.10(1.61 - 123.62)	4.76(2.17 - 10.42)	E
	4	2.06(1.25 - 3.40)	C	E
	6a	C	C	N.D.

TABLE 18. (Continued)

PVC	3	C	C	C
	6b	C	C	C
PVCZ	1	1.51(1.31 - 1.72)	1.51(1.08 - 2.12)	E
	2	1.29(1.09 - 1.53)	1.14(0.99 - 1.30)	C
	6b	1.10(0.91 - 1.35)	C	1.08(1.02 - 1.14)
REDO	5	1.41(0.99 - 2.01)	1.22(1.08 - 1.39)	H
	6	1.17(1.08 - 1.27)	C	H
	8	E	1.33(0.98 - 1.80)	H
RPU	4	C	C	C
	6b	1.11(1.06 - 1.16)	C	N.D.
	8	1.38(0.97 - 1.97)	C	C
WOOL	2	C	1.19(1.02 - 1.40)	C
	3	E	1.23(1.10 - 1.37)	E
	6	1.13(0.98 - 1.30)	1.09(1.04 - 1.15)	1.40(0.82 - 2.36)
	8	1.33(1.09 - 1.63)	1.66(0.46 - 6.00)	E

a: NBS small furnace

b: NBS large furnace

C: No slope as EC_{50} or LC_{50} > highest concentration tested

D: No slope as EC_{50} or LC_{50} < lowest concentration tested

E: EC_{50} or LC_{50} estimated

H: 440°C is equal to or within 50°C of non-flaming temperature

N.D. Not determined

17: Significantly heterogeneous data

19: Litchfield and Wilcoxon - reference 26.

20: Units are $\frac{\% \text{ effect (incapacitation or lethality)}}{\text{mg/l}}$

TABLE 19

Slopes of LC₅₀, 30 min. + 14 days. (95% confidence limits of slope)¹⁹

Material	Laboratory	Flaming	Non-flaming	440°C
ABS	1	1.58(1.34-1.85)	1.80(1.02-3.16)	1.20(1.07-1.36)
	3	1.23(1.08-1.40)	C	C
	5	1.46(1.13-1.89)	2.06(0.86-4.92)	C
	6b	1.37(1.09-1.72)	1.23(0.99-1.54)	N.D.
DFIR	1	1.41(1.06-1.89)	1.38(1.05-1.81)	H
	2	1.30(1.00-1.69)	1.26(1.04-1.53)	H
	3	E	1.64(0.0-3.85)	H
	4	1.69(0.66-4.30)	1.69(1.29-2.22)	H
	5	1.14(1.01-1.28)	1.73(1.25-2.41)	H
	6a	1.66(0.81-3.39)	1.43(1.09-1.88)	H
	6b	1.05(1.02-1.08)	1.25(1.10-1.42)	H
	8	1.51(0.61-3.73)	1.08(1.04-1.12)	H
FPU	3	C	1.87(1.19-2.94)	H
	4	C	2.37(1.46-3.84)	H
	6a&6b	C	2.37(0.93-6.01) ¹⁷	H
MOD	2	N.D.	1.11(1.02-1.21)	N.D.
	4	1.14(1.00-1.30)	1.40(1.18-1.66)	1.91(1.04-3.52)
	5	1.88(1.22-2.89)	1.70(1.23-2.36)	E
	6	1.30(1.10-1.53) ^a	1.67(0.99-2.81) ^a	1.35(1.09-1.68) ^{a, b}
PPS	2	1.23(1.09-1.38)	1.35(1.02-1.78)	C
	4	E	1.21(0.98-1.49)	C
	5	1.41(1.00-2.00)	1.31(1.07-1.61)	C
	6b	1.50(0.50-4.47)	1.07(1.04-1.11)	N.D.
PSTY	2	1.51(0.71-3.20)	C	H
	4	1.14(1.07-1.23)	C	N.D.
	6b	1.03(1.00-1.07)	C	H

TABLE 19 (Continued)

Material	Laboratory	Flaming	Non-flaming	440°C
PTFE	1	4.15(1.67-10.28)	2.07(1.29-3.31)	E
	4	5.10(1.80-14.43) ¹⁷	5.27(0.79-35.17) ¹⁷	N.D.
	6a	1.33(0.98-1.81)	7.94(1.28-49.31)	N.D.
PVC	3	E	E	1.63(1.18-2.26)
	6b	1.22(1.12-1.34)	1.47(1.03-2.09)	1.36(0.90-2.06)
PVCZ	1	1.51(1.19-1.91)	1.88(1.04-3.41)	1.52(1.19-1.93)
	2	1.24(1.08-1.43)	1.30(1.07-1.58)	C
	6b	E	1.42(0.65-3.1)	1.09(1.01-1.17)
REDO	5	1.30(1.00-1.70)	1.78(0.69-4.62)	H
	6a	1.15(1.07-1.24)	1.32(1.06-1.65)	H
	8	1.07(1.03-1.11)	2.29(0.49-10.69)	H
RPU	4	C	C	C
	6b	1.10(0.95-1.28)	C	N.D.
	8	1.83(0.15-21.68)	C	C
WOOL	2	1.39(0.97-1.99)	1.62(0.89-2.95)	C
	3	E	1.22(1.10-1.36)	E
	6	1.60(0.91-2.83) ^a	1.17(1.06-1.29) ^a	1.39(0.82-2.36) ^b
	8	1.86(0.83-4.14)	1.47(0.89-2.41)	1.15(0.87-1.52)

For explanation of superscript numbers and letters, see legend to table 18.

TABLE 20
Comparison of NBS EC₅₀ and LC₅₀ Values

Material	Mode	EC ₅₀ 30 min. (mg/l)	LC ₅₀ 30 min. + 14 days (mg/l)	LC ₅₀ 30 min. (mg/l)
ABS	F	ND	19.3(16.7 - 22.3)	31.5(24.7 - 40.2)
	NF	ND	30.9(21.2 - 45.0)	>32.5 ¹
DFIR-a	F	21.8(15.5 - 30.7) ¹⁷	41.0(33.0 - 50.9)	45.0(38.5 - 52.6)
	NF	18.3(14.5 - 23.0)	20.4(16.4 - 25.3)	34.8(29.1 - 41.7)
DFIR-b	F	~23.5[23.0 ¹ -24.0 ¹³]	39.8(38.2 - 41.4)	39.8(38.2 - 41.4)
	NF	13.5(12.9 - 14.2)	22.8(20.2 - 25.8)	29.0(23.4 - 36.0)
FPU	F	37.5(35.8 - 39.3)	>40 ⁵	>40 ⁵
	NF	53.0(40.1 - 69.9)	26.6(15.3 - 46.2) ¹⁷	>47.7 ⁵
MOD	F	3.1(2.2 - 4.3) ¹⁷	4.4(3.9 - 5.0)	5.0(4.2 - 5.9)
	NF	3.2(2.8 - 3.7)	5.3(4.0 - 7.1)	5.2(4.4 - 6.2)
	440	6.4(5.8 - 7.0)	7.3(6.3 - 8.5)	7.8(6.9 - 8.8)
PPS	F	ND	19.8(14.8 - 26.5)	20.0(16.8 - 23.8)
	NF	ND	9.5(9.1 - 10.1)	9.7(9.2 - 10.2)
PSTY	F	~28.7[27.5 ¹ -30.4 ¹³]	38.9(37.9 - 39.9)	38.9(37.9 - 39.9)
	NF	>40 ¹	>40 ¹	>40 ¹
PTFE	F	>0.251 ¹	0.045(0.039 - 0.054)	>0.251 ¹
	NF	>5.025 ¹	0.045(0.017 - 0.120)	>5.025 ¹
PVC	F	~18.5[17.5 ⁵ -19.8 ¹³]	17.3(14.8 - 20.2)	>30.0 ¹
	NF	>30.0 ⁵	20.0(14.7 - 27.2)	>25.0 ⁵
	440	>30.0 ⁵	25.0(20.2 - 31.0)	>30.0 ¹
PVCZ	F	ND	~15.0[15.0 ¹ -15.5 ¹³]	15.2(13.5 - 17.1) ¹⁷
	NF	ND	11.3(8.5 - 14.9)	>14.0 ⁸
	440	ND	12.8(12.1 - 13.6)	13.9(13.2 - 14.6)
REDO	F	34.8(31.1 - 39.0)	56.8(51.6 - 62.5)	59.0(54.5 - 63.9)
	NF	~23.0[22.5 ¹ -24.2 ¹³]	30.3(26.0 - 35.4)	>45 ¹
RPU	F	ND	13.3(12.2 - 14.5)	14.3(13.4 - 15.3)
	NF	ND	>39.6 ¹	>39.6 ¹
WOOL	F	~22.3[22.1 - 22.6 ¹³]	28.2(23.0 - 34.5)	40.9(38.1 - 43.8)
	NF	19.7(16.2 - 24.0)	25.1(22.3 - 28.3)	29.5(27.8 - 31.3)
	440	24.5(23.0 - 26.1)	32.1(30.2 - 34.1)	35.0(29.0 - 42.2)

*For explanation of superscript numbers and letters, see legend to table 16.

TABLE 21

Comparison of the Normalized Flaming LC₅₀ and EC₅₀ Data from all Laboratories

Material	$\frac{\text{LC}_{50} \text{ Material}}{\text{LC}_{50} \text{ DFIR}}$ (30 min. + 14 days)	$\frac{\text{LC}_{50} \text{ Material}}{\text{LC}_{50} \text{ DFIR}}$ (30 min.)	$\frac{\text{EC}_{50} \text{ Material}}{\text{EC}_{50} \text{ DFIR}}$ (30 min.)
REDO	1.53 ± 0.43 ^a (3) ^b	1.58 ± 0.52(3)	1.99 ± 0.64(2)
FPU	-	-	1.16 ± 0.70(2)
WOOL	1.15 ± 0.59(4)	1.27 ± 0.58(3)	1.17 ± 0.14(3)
PSTY	1.09 ± 0.10(3)	1.04 ± 0.06(3)	1.43 ± 0.29(2)
DFIR	1.00(8)	1.00(8)	1.00(7)
PPS	0.64 ± 0.40(4)	0.79 ± 0.42(4)	-
PVC	0.53 ± 0.13(2)	-	0.60 ± 0.26(2)
ABS	0.53 ± 0.10(4)	0.56 ± 0.05(4)	0.72 ± 0.43(3)
RPU	0.36 ± 0.03(2)	0.42 ± 0.09(2)	0.43(1)
PVCZ	0.32 ± 0.06(3)	0.36 ± 0.04(3)	0.65 ± 0.09(2)
MOD	0.16 ± 0.07(3)	0.16 ± 0.07(3)	0.17 ± 0.04(2)
PTFE	0.006 ± 0.006(3)	0.057 ± 0.040(2)	0.04(1)

a: Mean ± standard deviation calculated from values that were normalized to Douglas fir.

b: Number of data sets used to calculate mean.

It is important to note that the results shown in tables 21, 22, and 23 pertain to the particular samples tested during this study. The materials used were selected to represent a wide range of properties. No attempt was made to provide statistically valid samples of a given material. Therefore the results should not be used to judge any particular class of material.

.. TABLE 22

Comparison of the Normalized Non-flaming LC₅₀ and EC₅₀ Data from all Laboratories

Material	$\frac{\text{LC}_{50} \text{ Material}}{\text{LC}_{50} \text{ DFIR}}$ (30 min. + 14 days)	$\frac{\text{LC}_{50} \text{ Material}}{\text{LC}_{50} \text{ DFIR}}$ (30 min.)	$\frac{\text{EC}_{50} \text{ Material}}{\text{EC}_{50} \text{ DFIR}}$ (30 min.)
RPU	-	-	1.99(1)
REDO	1.45 ± 0.46 ^a (3) ^b	1.72(1)	1.45 ± 0.27(2)
FPU	1.31 ± 0.32(3)	-	1.83 ± 1.31(3)
ABS	1.27 ± 0.10(3)	1.01(1)	1.21 ± 0.18(3)
WOOL	1.07 ± 0.41(4)	0.94 ± 0.42(4)	1.40 ± 0.30(4)
DFIR	1.00(8)	1.00(7)	1.00(8)
PVC	0.74 ± 0.20(2)	-	1.68(1)
PPS	0.71 ± 0.44(4)	0.69 ± 0.53(3)	0.87 ± 0.01(2)
PVCZ	0.48 ± 0.02(3)	0.40 ± 0.06(2)	0.76 ± 0.56(2)
MOD	0.26 ± 0.06(4)	0.21 ± 0.13(3)	0.20 ± 0.06(3)
PTFE	0.006 ± 0.004(3)	0.04(1)	0.045(1)

a: Mean ± standard deviation calculated from values that were normalized to Douglas fir.

b: Number of data sets used to calculate mean.

It is important to note that the results shown in tables 21, 22, and 23 pertain to the particular samples tested during this study. The materials used were selected to represent a wide range of properties. No attempt was made to provide statistically valid samples of a given material. Therefore the results should not be used to judge any particular class of material.

TABLE 23

Comparison of the Normalized LC₅₀ and EC₅₀ Data at 440°C from All Laboratories

Material	$\frac{\text{LC}_{50} \text{ Material}}{\text{LC}_{50} \text{ DFIR}}$	$\frac{\text{LC}_{50} \text{ Material}}{\text{LC}_{50} \text{ DFIR}}$	$\frac{\text{EC}_{50} \text{ Material}}{\text{EC}_{50} \text{ DFIR}}$
	(30 min. + 14 days)	(30 min.)	(30 min.)
ABS	1.80 ^a (1) ^b	1.40(1)	1.48 ± 0.18(2)
REDO	1.45 ± 0.46(3)	1.72(1)	1.45 ± 0.27(2)
WOOL	1.37 ± 0.42(3)	1.22 ± 0.49(3)	2.66 ± 1.31(3)
DFIR	1.00(8)	1.00(7)	1.00(8)
PVC	0.93 ± 0.23(2)	-	2.41(1)
PTFE	0.90(1)	0.85 ± 0.22(2)	1.01(1)
PVCZ	0.54 ± 0.04(2)	0.54 ± 0.08(2)	0.87 ± 0.51(2)
MOD	0.32 ± 0.10(3)	0.33 ± 0.12(2)	0.33 ± 0.10(2)

a: Mean ± standard deviation calculated from values that were normalized to Douglas fir.

b: Number of data sets used to calculate mean.

It is important to note that the results shown in tables 21, 22, and 23 pertain to the particular samples tested during this study. The materials used were selected to represent a wide range of properties. No attempt was made to provide statistically valid samples of a given material. Therefore the results should not be used to judge any particular class of material.

TABLE 24

NBS 10 Minute Test @ 30 mg/l

Material	Mode	Temp. (°C)	Percent Incapacitation	Percent Death			COHb Highest	Maximum HCN, ppm
				10 min.	10 min. post-exp.	10 min. + 14 days		
PVC-ZnFeCN	F	700	100	16.7	16.7	100	-	446
			100	0	16.7	100	46.3	330
	NF	650	100	50	16.7	100	-	858
			100	16.7	16.7	100	14.1	1095
	NF	440	100	0	0	100	2.9	396
PVC	F	625	0	0	0	0	27.5	
			0	0	0	20	22.8	
			0	0	0	0	14.4	
	NF	575	0	0	0	0	-	
			0	0	0	0	-	

TABLE 25

NBS Carboxyhemoglobin and Gas Concentration Values at
 LC₅₀ (30 min + 14 days) - Flaming Combustion

<u>Material</u>	<u>Deaths</u>	<u>Auto Ignition Temp(°C)</u>	<u>LC₅₀ † (mg/l)</u>	<u>COHb (%)</u>	<u>CO (ppm)</u>	<u>HCN (ppm)</u>
PPS	W,P	650	19.8	82	3500	-
DFIR b	W	465	39.8	83	3400	-
DFIR a	W	465	41.0	84	3000	-
REDO	W	480	56.8	83	2800	-
PVCZ	W,P	675	~15.0	~68	~2200	~110
RPU	W	550	13.3	61	1700	130
ABS	W	575	19.3	42	1500	130
PSTY	W	490	38.9	78	1300	-
PVC	P	600	17.3	49	1100	-
FPU	W	370	>40	>65	>960	>22
WOOL	W,P	650	28.2	43	700	130
MOD	W,P	725	4.4	22	400	180

a: NBS small furnace

b: NBS large furnace

W: Within exposure

P: Post-exposure

†: For 95% confidence limits, see Table 17, laboratory 6

TABLE 26

NBS Carboxyhemoglobin and Gas Concentration Values at
 LC₅₀ (30 min + 14 days) -Non-Flaming Combustion

<u>Material</u>	<u>Deaths</u>	<u>Auto Ignition Temp (°C)</u>	<u>LC₅₀ † (mg/l)</u>	<u>COHb (%)</u>	<u>CO (ppm)</u>	<u>HCN (ppm)</u>
PPS	W	650	9.5	84	4400	-
DFIR b	W,P	465	22.8	81	2700	-
REDO	P	480	30.3	80	2400	-
DFIR a	P	465	20.4	80	2100	-
RPU	*	550	>39.6	>47	>1700	>44
PVCZ	P	675	11.3	36	1200	150
WOOL	W,P	650	25.1	41	920	240
FPU	P	370	26.6	54	820	10
ABS	P	575	30.9	27	670	160
PVC	P	600	20.0	27	590	-
MOD	W	725	5.3	16	430	250
PSTY	*	490	>40.0	>6	>72	-

*No deaths in range studied.

a: NBS small furnace

b: NBS large furnace

W: Within exposure

P: Post-exposure

†: For 95% confidence limits, see Table 17, laboratory 6

U.S. DEPT. OF COMM. BIBLIOGRAPHIC DATA SHEET	1. PUBLICATION OR REPORT NO. NBSIR 82-2532	2. Gov't Accession No.	3. Recipient's Accession No.
4. TITLE AND SUBTITLE Further Development of a Test Method for the Assessment of the Acute Inhalation Toxicity of Combustion Products		5. Publication Date June 1982	
7. AUTHOR(S) Barbara C. Levin, Andrew J. Fowell, Merritt M. Birky, Maya Paabo, Alan Stolte, Dolores Malek		6. Performing Organization Code	
9. PERFORMING ORGANIZATION NAME AND ADDRESS NATIONAL BUREAU OF STANDARDS DEPARTMENT OF COMMERCE WASHINGTON, DC 20234		8. Performing Organ. Report No.	
12. SPONSORING ORGANIZATION NAME AND COMPLETE ADDRESS (Street, City, State, ZIP)		10. Project/Task/Work Unit No.	
15. SUPPLEMENTARY NOTES <input type="checkbox"/> Document describes a computer program; SF-185, FIPS Software Summary, is attached.		11. Contract/Grant No.	
16. ABSTRACT (A 200-word or less factual summary of most significant information. If document includes a significant bibliography or literature survey, mention it here.) This report describes the development of a test method for the assessment of acute inhalation toxicity of combustion products of materials. The procedure is primarily intended for research and screening purposes. It provides: 1) a method for determining, under flaming and non-flaming conditions, the LC ₅₀ (the concentration of combustion products which causes 50% lethality in the test animals (rats) exposed for 30 minutes and observed for 14 days following exposure); 2) an optional procedure to examine materials which rapidly produce combustion products which cause death of test animals within a 10 minute exposure and a 14 day post-exposure observation period; and 3) a description of analytical and physiological measurements which can provide more detailed information on the nature of the toxic effects of combustion products. Limitations of the test method are identified and future work to address them is proposed. The participation through the direct exchange of technical information of organizations representing academia, industry, and other agencies of the United States Government is acknowledged.		13. Type of Report & Period Covered	
17. KEY WORDS (six to twelve entries; alphabetical order; capitalize only the first letter of the first key word unless a proper name; separated by semicolons) combustion products; flaming combustion; inhalation; materials; non-flaming combustion; test method; toxicity.		14. Sponsoring Agency Code	
18. AVAILABILITY <input checked="" type="checkbox"/> Unlimited <input type="checkbox"/> For Official Distribution. Do Not Release to NTIS <input type="checkbox"/> Order From Sup. of Doc., U.S. Government Printing Office, Washington, DC 20402, SD Stock No. SN003-003- <input checked="" type="checkbox"/> Order From National Technical Information Service (NTIS), Springfield, VA. 22161	19. SECURITY CLASS (THIS REPORT) UNCLASSIFIED	21. NO. OF PRINTED PAGES 143	
	20. SECURITY CLASS (THIS PAGE) UNCLASSIFIED	22. Price \$13.50	