

Future for Offshore Wind Energy in the United States

Preprint

W. Musial
S. Butterfield

*To be presented at EnergyOcean 2004
Palm Beach, Florida
June 28-29, 2004*



NREL

National Renewable Energy Laboratory
1617 Cole Boulevard, Golden, Colorado 80401-3393
303-275-3000 • www.nrel.gov

Operated for the U.S. Department of Energy
Office of Energy Efficiency and Renewable Energy
by Midwest Research Institute • Battelle

Contract No. DE-AC36-99-GO10337

NOTICE

The submitted manuscript has been offered by an employee of the Midwest Research Institute (MRI), a contractor of the US Government under Contract No. DE-AC36-99GO10337. Accordingly, the US Government and MRI retain a nonexclusive royalty-free license to publish or reproduce the published form of this contribution, or allow others to do so, for US Government purposes.

This report was prepared as an account of work sponsored by an agency of the United States government. Neither the United States government nor any agency thereof, nor any of their employees, makes any warranty, express or implied, or assumes any legal liability or responsibility for the accuracy, completeness, or usefulness of any information, apparatus, product, or process disclosed, or represents that its use would not infringe privately owned rights. Reference herein to any specific commercial product, process, or service by trade name, trademark, manufacturer, or otherwise does not necessarily constitute or imply its endorsement, recommendation, or favoring by the United States government or any agency thereof. The views and opinions of authors expressed herein do not necessarily state or reflect those of the United States government or any agency thereof.

Available electronically at <http://www.osti.gov/bridge>

Available for a processing fee to U.S. Department of Energy and its contractors, in paper, from:

U.S. Department of Energy
Office of Scientific and Technical Information
P.O. Box 62
Oak Ridge, TN 37831-0062
phone: 865.576.8401
fax: 865.576.5728
email: <mailto:reports@adonis.osti.gov>

Available for sale to the public, in paper, from:

U.S. Department of Commerce
National Technical Information Service
5285 Port Royal Road
Springfield, VA 22161
phone: 800.553.6847
fax: 703.605.6900
email: orders@ntis.fedworld.gov
online ordering: <http://www.ntis.gov/ordering.htm>



FUTURE FOR OFFSHORE WIND ENERGY IN THE UNITED STATES

Walt Musial
Sandy Butterfield
National Renewable Energy Laboratory
1617 Cole Boulevard
Golden, CO 80401 USA
walter_musial@nrel.gov
sandy_butterfield@nrel.gov

Abstract

Until recently, the offshore wind energy potential in the United States was ignored because vast onshore wind resources have the potential to fulfill the electrical energy needs for the entire country. However, the challenge of transmitting the electricity to the large load centers may limit wind grid penetration for land-based turbines. Offshore wind turbines can generate power much closer to higher value coastal load centers. Reduced transmission constraints, steadier and more energetic winds, and recent European success, have made offshore wind energy more attractive for the United States. However, U.S. waters are generally deeper than those on the European coast, and will require new technology. This paper presents an overview of U.S. coastal resources, explores promising deepwater wind technology, and predicts long-term cost-of-energy (COE) trends. COE estimates are based on generic 5-MW wind turbines in a hypothetical 500-MW wind power plant. With sufficient R&D technology improvements and volume production, analysis shows that costs could reach \$0.051/kWh for deployment of deepwater offshore wind turbines by 2015, and \$0.041/kWh by 2012 for shallow water in class 6 winds. Offshore wind systems can diversify the U.S. electric energy supply and provide a new market for wind energy that is complementary to onshore development.

Background

The worldwide installed capacity of grid-connected wind power has now exceeded 40 GW, corresponding to an investment of approximately \$40 billion [1]. The global wind energy installed capacity has increased exponentially over a 25-year period, and in the process the cost of energy (COE) from wind power plants has been reduced by an order of magnitude.

Wind energy installations in the United States have grown during the past decade from about 1800 MW in 1990 to more than 6,000 MW at the end of 2003. Development has mainly focused on Class 6 (high wind sites with an annual average wind speed of 15 mph) in remote areas of the West, and on a few ridgelines in the East. To take advantage of much broader resources closer to load centers, the U.S. Department of Energy (DOE) is conducting the Low Wind Speed Technology Project, which targets development of cost-effective wind turbines for Class 4 sites (13-mph average annual wind speed) that can produce electricity onshore for \$0.03/kWh and offshore for \$0.05/kWh by the end of 2012. This will open up 20 times more land in the United States for wind energy development, and since many of these sites tend to be closer to urban load centers, the problem of transmission line expansion will be greatly simplified. However, many

large East Coast load centers will never be able to benefit from the energetic winds that sweep the Midwest. For those regions, offshore wind is the logical solution.

Offshore wind turbines have a number of advantages over onshore ones. The size of onshore turbines is constrained by capacity limitations of the available transportation and erection equipment. Transportation and erection problems are mitigated offshore where the size and lifting capacities of marine shipping and handling equipment still exceed the installation requirements for multimegawatt wind turbines. Onshore, particularly in Europe or on the East Coast of the United States, the visual appearance of massive turbines in populated areas may be undesirable. At a sufficient distance from the coast, visual intrusion is minimized and wind turbines can be larger, thus increasing the overall installed capacity per unit area. Similarly, less attention needs to be devoted to reduce turbine noise emissions offshore, which adds significant costs to onshore wind turbines. Also, the wind tends to blow faster and more uniformly at sea than on land. A higher, steadier wind means less wear on the turbine components and more electricity generated per square meter of swept rotor area. Onshore turbines are often located in remote areas, where the electricity must be transmitted by relatively long power lines to densely populated regions, but offshore turbines can be located close to high-value urban load centers, simplifying transmission issues.

On the negative side of offshore development, investment costs are higher and accessibility is more difficult, resulting in higher capital and maintenance costs. Also, environmental conditions at sea are more severe: more corrosion from salt water and additional loads from waves and ice. And obviously, offshore construction is more complicated.

Despite the difficulties of offshore development, it holds great promise for expanding wind generation capacity. In Europe and the eastern United States, the amount of space available for offshore wind turbines is many times larger than for onshore ones. A sizable fraction of the future growth in Europe will likely happen offshore [2]. Indeed, the European wind industry has already begun to shift its focus offshore. At the end of 2003, the total installed capacity of offshore wind energy was 529 MW [3].

Offshore Resource

Mesoscale weather prediction models have recently been refined and are used to map the wind resource potential on land. This resource estimation methodology has been validated for onshore applications against actual anemometer data for several U.S. geographic regions. Although these models are new and have not been fully validated in all climatological situations, they are more accurate than the earlier boundary layer prediction methods used in conjunction with measured data. Mesoscale modeling used to determine the onshore wind resource for many of the coastal states has also provided preliminary estimates of wind resources out to 50 nautical miles (nm) offshore for recently mapped regions of the United States [4]. The new resource maps indicate immense areas of Class 5, 6, and some Class 7 winds at distances from 5 nm offshore to 50 nm offshore (see Figure 1). Table 1 gives the annual average wind speed at 50-m height above the ground for the various wind speed classes determined for offshore sites. This table includes the effects of wind shear referenced to a 50-m elevation.

**Table 1 – Reference Table for Wind Speed Classes at Offshore Sites
(Ranges are given in m/s)**

WS m/s 50 M	Class
5.6-6.4	Class 2
6.4-7	Class 3
7-7.5	Class 4
7.5-8	Class 5
8-8.8	Class 6

Although the modeling is not fully validated for offshore conditions, and modeling of the entire U.S. coastline has not been completed, the data provide the best current estimate of the offshore wind potential for the United States. Table 2 provides a summary of the estimated offshore resource by region and water depth. Deep water is defined as greater than 30 m.

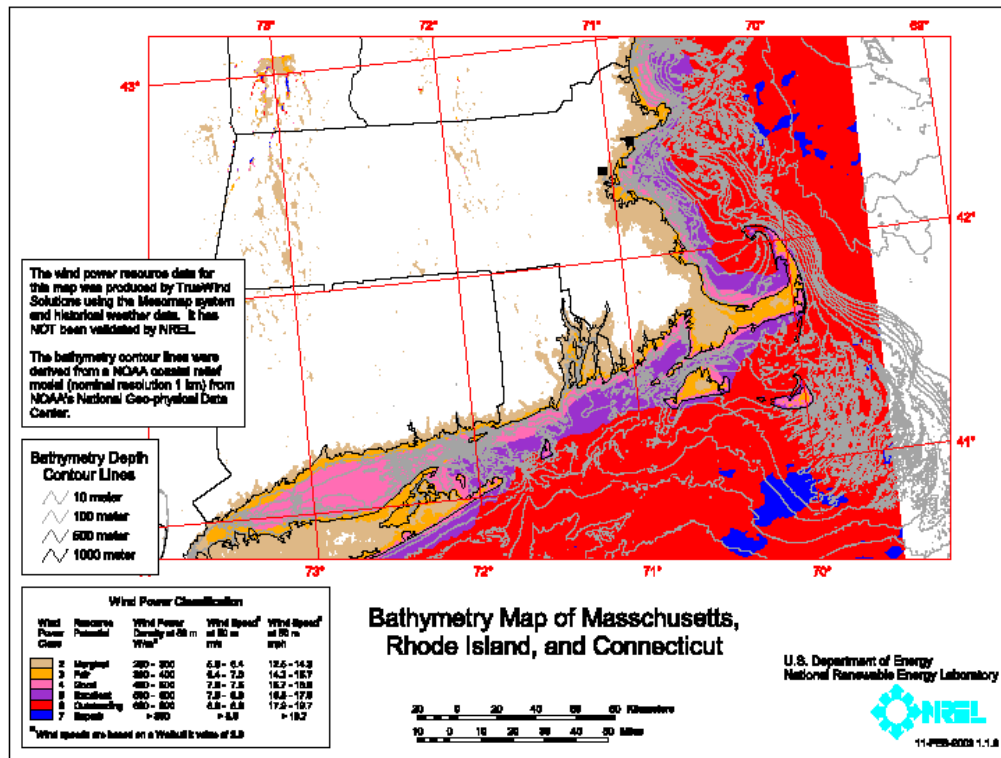

Figure 1 – Offshore Wind Energy Resource for New England

Table 2 – U.S. Offshore Wind Energy Resource by Region for Shallow and Deep Water

Offshore Resource Estimates						
Resource in MW						
Region	5-20 Nautical Miles			20 - 50 Nautical Miles		
	Shallow <30 m	Deep	% Exclusion	Shallow <30 m	Deep	% Exclusion
New England	9,900	41,600	67%	2,700	166,300	33%
Mid Atlantic States	46,500	8,500	67%	35,500	170,000	33%
California	2,650	57,250	67%	0	238,300	33%
Pacific Northwest	725	34,075	67%	0	93,700	33%
Totals	59,775	141,425	67%	38,200	668,300	33%

In the analysis it was assumed that the offshore zone from the shoreline to 5 nm is 100% excluded to reduce viewshed issues and to avoid the rich ecosystem near shore, where environmental concerns are likely to be of primary concern. Furthermore, for the estimates in the offshore zone from 5 nm to 20 nm, where there are more avian, marine mammal, fish, and view shed concerns, 67% of the potential area is excluded. The reduction of 67% represents the most severe constraint previously used for onshore estimates. The reductions need to be refined by developing overlay maps of the wind resource and the restricted areas to eliminate environmentally sensitive areas, shipping routes, fisheries, various animal habitats, and other restricted areas. For the zone from 20 nm to 50 nm, where there are fewer environmental concerns and wind farms are not visible, the exclusion was reduced to 33%, which again represents onshore experience for situations with moderate restrictions. These are the best available estimates of offshore wind resource, but the results were compiled from computer runs made with different versions of the model as it was improved over time. Some of the earlier runs may have to be verified. In addition, the exclusions need to be established more rigorously. The models also need to be validated from wind speed measurements made at sea. Methods are under development to measure wind speed over the water at elevations where turbines operate.

All told, areas between 5 nm and 50 nm off the coast of the United States contain about 907 GW of wind potential; an amount greater than current installed U.S. electrical capacity. Additional resources in the Gulf Coast and Great Lakes regions have yet to be fully characterized and have not yet been quantified. Much of this resource lies close to major urban load centers with high energy costs, and can be brought to market with less new transmission construction.

Water Depth

Offshore wind development has been limited to waters shallower than 30 m in the North and Baltic Seas. At depths less than 30 m, the established monopile foundation technologies can be deployed without significant R&D effort. For many European countries, such as Denmark, the Netherlands, Germany, and the United Kingdom, these shallow water sites appear to be abundant, and should allow offshore wind installations to proliferate rapidly in the near term. In the United States, approximately 500 MW of shallow water development is underway, but to date, no installations have been permitted. Our estimates indicate that of the 907 GW offshore wind resource outside 5 nm, a little more than 10% or 98 GW is over shallow water (depth of less than 30 m). The remaining 810 GW of offshore wind resource is over water 30 m and deeper. New technologies will need to be developed to take advantage of this vast resource.

Current Offshore Turbine Technology

Present-day offshore wind power plants are located in very shallow water of 5 m to 12 m. Turbine manufacturers have taken conventional land-based turbine designs, upgraded their electrical and corrosion control systems to marinize them, and placed them on concrete bases or steel monopiles to anchor them to the seabed. An offshore substation boosts the collection system voltage, and a buried undersea cable carries the power to shore where another substation provides a further voltage increase for transmission to the loads.

Operating experience has shown that there is much to be learned about deployment of offshore wind turbines in terms of achieving the same reliability and low COE as their land-based

counterparts. Increased complexity of offshore construction and operation and maintenance (O&M) has begun to bring in a higher regimen of new technologies derived from the marine and offshore industries. Offshore projects must be larger, in terms of both turbine size and project scale, to pay for the added turbine seabed support structures and cabling costs. In addition, turbine structural dynamics and fatigue loadings are much more complex and difficult to analyze offshore. All these complexities add uncertainty and cost that must be reduced through supporting R&D and demonstrative experience, to validate to investors the turbine designs and prove the viability and profitability of offshore wind. The application-specific experience now being gained on the proving grounds of these early installations will be essential as the wind industry expands offshore technology to other oceans and greater depths.

Future Deepwater Wind Turbine Technology

When offshore wind installations arrive in the United States, more severe ocean conditions and greater water depths will challenge designers. Wind, wave, tide, and current conditions are less well defined in the Atlantic than for the shallower and more sheltered Baltic and North Seas. New wind and wave interaction models will need to be developed. As the shallowest sites are developed, installations will naturally progress into deeper water that will require alternative substructures to support the turbines. These structures may require a more complicated subsea tripod or truss tower arrangement for fixed bottom systems. The 98 GW of shallow water wind energy potential (5 to 50 nm offshore) offers an early market for the wind industry to develop technical capabilities, experience, and sales. At some depth, the development of floating platforms for wind turbines will be necessary to deploy wind turbines in even deeper waters. This progression is illustrated in Figure 2.

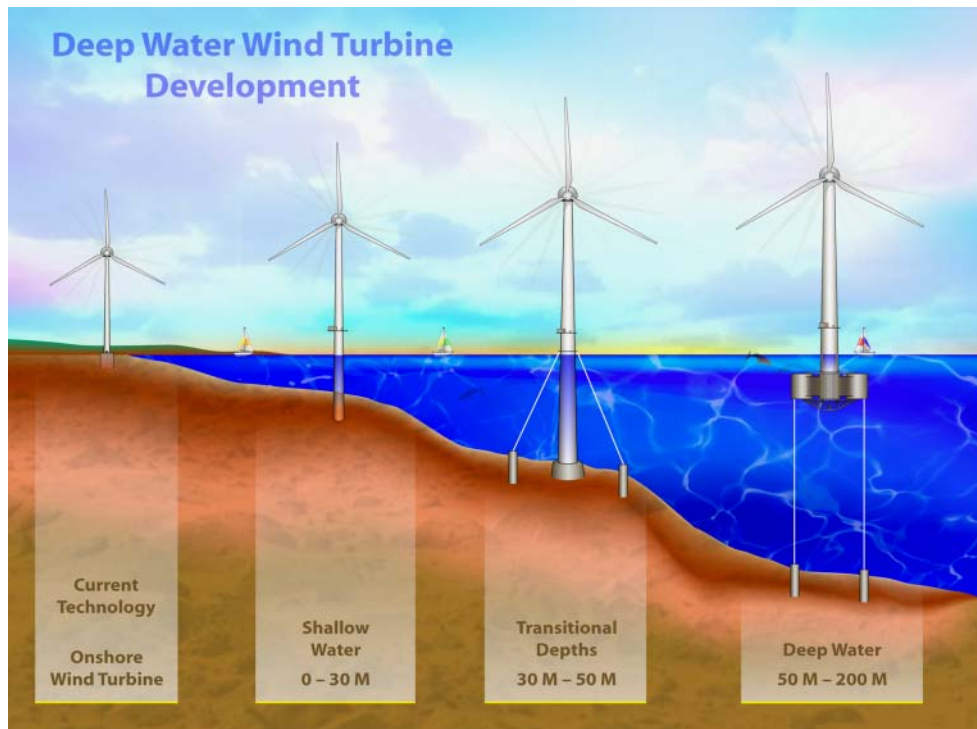

Figure 2 – Progression of Expected Wind Turbine Evolution to Deeper Water

This deepwater technology will require a more extensive development effort because of the added complexity of dynamic floating platforms and other design conditions at the more exposed sites further from shore. Floating structures have already been successfully demonstrated by the marine and offshore oil industries. However, the technical requirements and economics that allowed the deployment of thousands of offshore oilrigs have yet to be demonstrated for floating wind turbine platforms.

Basically, a floating structure will replace conventional steel monopiles or concrete bases. The additional capital costs for the wind turbines will not be significantly higher than current maritized turbines in shallow water. Therefore, the economics of deepwater wind turbines will be determined primarily by the additional cost of the floating structure and power distribution system. The floating structure must provide enough buoyancy to support the weight of the turbine and to restrain pitch, roll, and heave motions caused by the wind and wave forces.

The proven offshore floating platforms used by the oil and gas industry have characteristics similar to those being considered for floating wind turbine platforms, but their differences will allow the necessary cost reductions.

- Oil platforms' safety margins are higher to provide permanent residences for personnel.
- Oil platforms must allow for personnel evacuation. Wind platforms are mostly unmanned.
- Oil platforms must provide additional safety margins and stability for spill prevention. These are not concerns with wind platforms.
- Wind platforms need only be deployed in water as deep as 600 ft. Floating oil tension leg platforms range in depths from 1500 ft to 8000 ft.
- Wind turbine platforms can be submerged to minimize the structure exposed to wave loading. Oil platforms maximize above-water deck area and payload.

The biggest challenge for deepwater wind turbines will be to merge the mature but expensive technologies borne of the oil and gas industry with the experience and low-cost economic drivers fueling the shallow water offshore wind energy industry.

Estimated Cost of Energy

The approach that was taken for this cost study was to assume a nominal 500-MW wind plant composed of 100 machines, each with a 5-MW rating. The cost of the machines, including maritization and industry data, was scaled from WindPACT studies [5,6,7,8]. Two platform concepts were used, as described by Musial and Butterfield [9]. One was a concept developed by NREL; the other under a European study [10]. Costs were scaled over time with learning curves, which are typical of wind industry experience [14,15,18]. These costs were compared to long-term cost expectations for shallow water. This allowed a tangible starting point for cost estimates.

First the cost estimates for shallow water technology, taken from a number of European offshore project papers, are provided in Table 3 [15,16,17,18,19]. These estimates are based on water shallower than 30 m, consistent with the deepest European experience. Foundations are based on steel monopile foundations. Because the turbines in this study are larger than those currently

used in Europe (2- to 2.5-MW units), the foundation costs were scaled to match the increased loading for a 5-MW unit. The wind farm is 15-nm offshore, out of site from land. It is assumed to be a Class 6 wind site, which is consistent with the resource estimates described earlier. Cost projections have been made at 6 intervals from 2006 through 2025.

Table 3 – Shallow Water Cost Estimates for Offshore Wind – Class 6 Winds

Shallow Water Wind COE Estimates - Class 6 - <30-m depth, 15-miles from shore						
(\$ in Thousands)						
	Year of Installation					
	2006	2009	2012	2015	2020	2025
Turbine Size	5	5	5	5	5 MW	5 MW
Wind Farm Size	500 MW	500 MW	500 MW	500 MW	500 MW	500 MW
Rotor Diameter	128	128	128	128	128 M	128 M
Hub Height	80	80	80	80	80 M	80 M
Assumed Water Depth	<30-m	<30-m	<30-m	<30-m	<30-m	<30-m
Turbine Cost (total plant)	\$338,730	\$308,244	\$289,750	\$258,746	\$237,184	\$229,278
Monopile foundations (total plant)	\$99,200	\$87,296	\$76,820	\$67,602	\$61,969	\$59,903
Electrical Infrastructure	\$159,300	\$144,963	\$136,265	\$128,089	\$117,415	\$113,501
ICC / Rating (\$/kw)	\$1,194	\$1,081	\$1,006	\$909	\$833	\$805
O&M (\$/kwh)	\$0.0150	\$0.0132	\$0.0116	\$0.0102	\$0.0092	\$0.0083
LRC (Yr/total plant)	\$5,000	\$5,000	\$5,000	\$5,000	\$5,000	\$5,000
Capacity Factor (%)	0.42	0.44	0.47	0.47	0.47	0.47
Availability (%)	0.85	0.9	0.95	0.95	0.95	0.95
Shallow water COE - \$/kWh	\$0.054	\$0.046	\$0.041	\$0.037	\$0.034	\$0.032

All costs are estimated at the point of onshore delivery to the utility bus bar and are assumed to be unsubsidized. Future cost projections account for improvements in technology, increased production volume at current growth rates, learning curve effects, and improvements in operational proficiency.

A range of turbine design options that have been restricted in land-based units may have the potential for reducing offshore costs. Studies have shown that very high tip-speed designs and reduced blade chord can reduce loads throughout a wind turbine structure and reduce costs. These designs have been restricted on land because of increased aero-acoustics noise emissions, but offshore installations would not be subject to the same limitations. Based on the WindPACT rotor study [5], these improvements can reduce the COE by as much as 15%. Design modifications such as downwind operation and the possibility of using high-tip speed flexible designs could further reduce capital cost. Such design improvements are assumed in the model to yield a 5% cost improvement in the year 2015.

Another major factor, which must be included in any projections of offshore development, is the production learning curve. This is often expressed as a reduction in cost for each doubling in installed capacity. It is based on the fact that increased production volume results in improvements in manufacturing, assembly, and installation techniques, which in turn lower the per-unit costs. Higher volumes mean costs from suppliers are also reduced. The International Energy Agency estimates that learning curve cost reductions for wind turbines are 18% per doubling of installed capacity. In a 2002 study Milborrow determined using worldwide production data that wind turbine prices have been declining at a rate of 15.3% [18]. This same study indicates lower rates of 12.4% for an individual supplier. Milborrow forecasts that larger

machines and improved production techniques will cause an onshore wind turbine's cost to fall by 15% for every doubling of global installed capacity – and historically doubling has occurred about every 2.88 years. Milborrow contends that if these trends continue, costs will fall about 40% by 2012 [14]. Based on these reports, a learning curve factor of 12% cost reduction for each doubling in production appears reasonable. Further, since installed wind energy capacity has doubled every 3 years since 1990, offshore installation rates would presumably follow a similar trend for the early stages of development. However, if the existing world capacity of 40-GW doubles every three years over the next two decades, installed wind capacity will exceed the demand. To address this, two learning curves were used for the analysis; one to cover the turbine and electrical infrastructure, and one to cover the foundations and O&M costs. Turbines and electrical infrastructure are more mature and costs will be an extension of the learning curve already in progress for land-based wind systems. The less mature offshore foundation and O&M technologies will experience more rapid declines and start from a smaller base of machines. For the near term, both trends were assumed to use the 12% learning curve factor. The rate of doubling for turbines and infrastructure was assumed to ramp quickly to 6 years, while the doubling rate for foundations and O&M stayed at 3 years. O&M costs for offshore turbines is likely to remain significantly higher than for onshore systems due to the added complexities of working at sea. A baseline variable O&M rate of \$.015/kWh was used for the shallow water turbines. This is up to three times higher than typical onshore rates [20].

Deepwater Cost of Energy – Results

For deepwater systems, costs have been calculated for a 600-ft water depth, although studies show that significant resources can be developed in much shallower water with correspondingly lower costs. The deepwater turbine and tower are assumed to be the same for shallow and deep water, with an initial marinization cost premium of 11% higher than the land-based value. The major differences between deep and shallow water were due to the higher cost of floating platforms and the additional electrical cabling in deeper water. In addition, baseline O&M costs for deepwater turbines were assumed to be higher (\$.018/kWh) than shallow water turbines due to the added platform hardware and nominally greater distances to shore. Most other assumptions remain the same.

Electrical infrastructure costs were based on an unpublished NREL report [21]. These costs were higher for the deep-water cases because of greater distances offshore and riser designs necessary to reach from the bottom to the floating platforms. In both cases 34.5-kV service was used for distribution among the wind plant and 138 kV was used for interconnection from the plant to shore. Redundancy was incorporated in the distribution system to allow for full power transmission with a single fault within the system.

Musial et al. [9] estimated platform costs for two 5-MW floating platform configurations, one designed by NREL (Figure 3) and a Dutch Tri-Floater concept (Figure 4) designed under a European Union-funded study on floating platforms [10]. NREL's design was less detailed than the Dutch Tri-Floater, but NREL used the Dutch study to attain similar levels of conservatism and estimates for miscellaneous hardware. These assumptions are described by Musial et al. [9].

This study focuses on the NREL TLP concept. Musial et al. estimate that low volume TLP production costs would be \$2.88 to \$6.50 million. The midrange cost of \$4.69 million was

chosen as the mean baseline deepwater platform cost, with the upper and lower costs estimates taken as conservative and optimistic values to define a range of reasonable baseline platform costs. These costs are shown in Table 4.

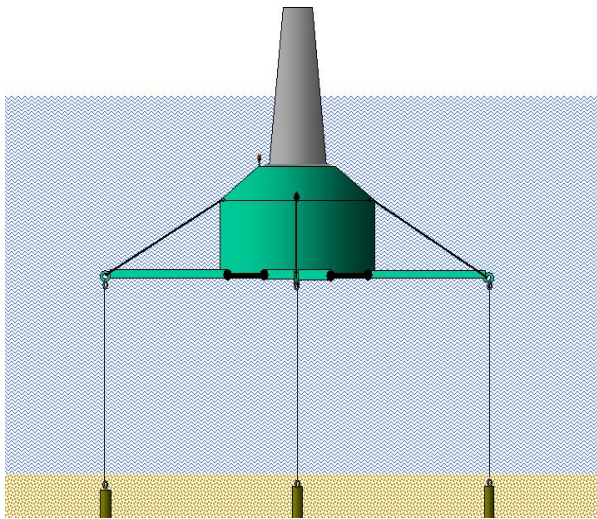

Figure 3 – NREL TLP Concept



Figure 4 – Dutch Trifloater Concept

With the assumptions stated earlier, and if research, design, and production begin in the near future, results shown in Table 4 indicate that class 6 baseline deepwater COE estimates for wind energy will range from \$0.095/kWh to \$0.071/kWh. The mean baseline for class 6 winds is \$0.083/kWh. By 2020, mean costs drop below \$0.045 for the NREL TLP. These costs put deepwater offshore wind energy solidly in competition with onshore electrical energy generating sources, but they are not possible without research to initiate the technology.

Table 4 – NREL TLP Cost of Energy Projections – Class 6 Winds

NREL Deep Water Wind COE Estimates - Class 6 (\$ in Thousands)						
	Year of Installation					
	2006	2009	2012	2015	2020	2025
Turbine Size	5	5	5	5	5 MW	5 MW
Wind Farm Size	500 MW	500 MW	500 MW	500 MW	500 MW	500 MW
Rotor Diameter	128	128	128	128	128 M	128 M
Hub Height	80	80	80	80	80 M	80 M
Assumed Water Depth	600 ft	600 ft	600 ft	600 ft	600 ft	600 ft
Turbine Cost (total plant)	\$338,730	\$308,244	\$289,750	\$245,128	\$224,701	\$217,211
Mean Floating Platform (total plant)	\$469,000	\$384,580	\$329,200	\$289,696	\$231,757	\$185,406
Electrical Infrastructure	\$194,200	\$176,722	\$166,119	\$156,152	\$143,139	\$138,368
ICC / Rating (\$/kw)	\$2,004	\$1,739	\$1,570	\$1,382	\$1,199	\$1,082
O&M (\$/kwh)	\$0.0180	\$0.0148	\$0.0126	\$0.0111	\$0.0102	\$0.0099
LRC (Yr/total plant)	\$5,000	\$5,000	\$5,000	\$5,000	\$5,000	\$5,000
Capacity Factor (%)	0.42	0.44	0.47	0.47	0.47	0.47
Availability (%)	0.85	0.90	0.95	0.95	0.95	0.95
COE - Mean Estimate \$/kWh	\$0.083	\$0.068	\$0.058	\$0.051	\$0.045	\$0.041
COE - Conservative Estimate \$/kWh	\$0.095	\$0.077	\$0.066	\$0.058	\$0.050	\$0.046
COE - Optimistic Estimate \$/kWh	\$0.071	\$0.059	\$0.051	\$0.045	\$0.040	\$0.037

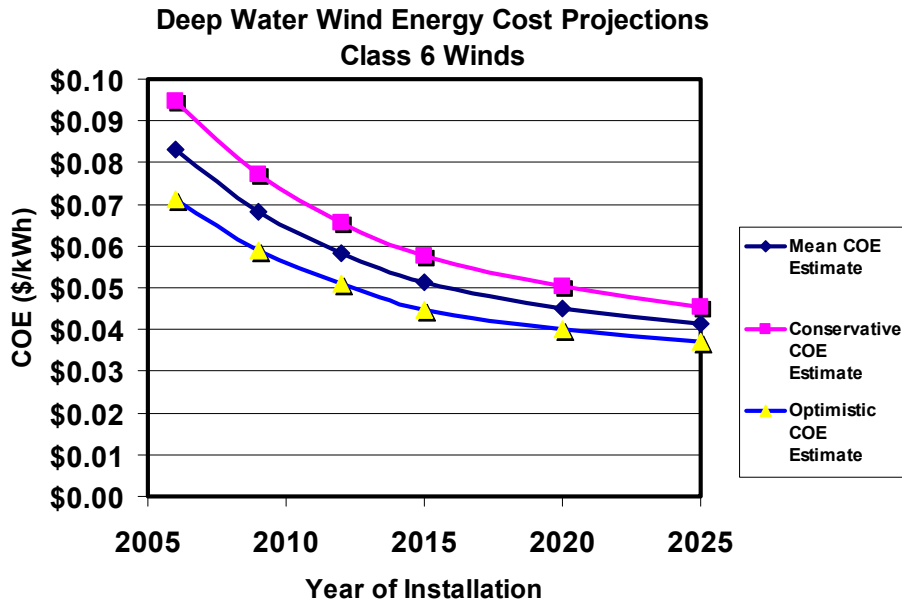

Figure 5 – COE Projections for NREL TLP Concept in Class 6 Winds

Deepwater Research and Development Strategy

In the arena of floating wind energy platforms, a pathway composed of a comprehensive R&D program, commercial demonstration, and subsequent mass production can probably reduce costs by 50% or more. Significant research is needed in the areas of anchoring, platform/turbine interactions, and understanding wind and wave loading on structures. Use of cheaper materials, such as concrete with composites, may further reduce the cost of buoyancy tanks and pontoons. Wind turbine design optimization for offshore conditions is also expected to reduce total operating costs in multiple ways. Lighter turbines and support structures will reduce system weight and hence the buoyancy requirements for floating platforms. To reduce system weight, wind turbines are expected to take advantage of higher tip speeds, advanced lightweight materials for blades, smaller and lighter weight generators, and perhaps new rotor configurations with two blades instead of three. Furthermore, the system cost can be reduced through improved rotor designs that increase energy capture. The need for greater machine reliability in these remote locations may drive turbine designs toward simpler, lighter weight drive trains, such as direct-drive generators without mechanical gearboxes. But to achieve these ends, design and implementation must use a total systems approach that assesses each design step according to its impact on the total system’s weight and cost.

To successfully achieve cost-competitive deepwater technologies, key collaborations must take place between three critical groups:

- 1) The oil and gas/marine industry
- 2) The present shallow water offshore wind energy industry
- 3) A targeted deepwater wind energy research community

The first group possesses generations of experience in building and operating large structures and vessels at sea. Oil and gas companies have deployed thousands of offshore oil platforms.

Demonstrably, the technology to make floating structures survive at sea under extreme conditions is understood. But these industries work under a different set of market constraints that involve a higher degree of human and environmental safety. The competitive wind energy markets need to redefine these technologies in terms of their own risk and reliability criteria specified by the wind energy experts.

Thus, the second group will develop and transfer essential experience in offshore wind turbine operation that is directly applicable to deep water. These issues include O&M experience, safety and reliability specifications, turbine marinization, wind and wave interactions, array effects, permitting and ecological issues, and standardization models. Without question, many of these areas will have to be taken to a new level of sophistication for deepwater deployments, but the technical foundations will be formed through this shallow water experience. Without wind energy experience in shallow water, the risk to deepwater wind projects may be too great, and oil and gas cost drivers may result in noncompetitive pricing.

The experience gained from the petroleum and the offshore wind industries together is essential—but not sufficient—to achieve cost-competitive deepwater wind energy in the next decade. Most countries that are actively engaged in the development of offshore wind, such as Denmark, Netherlands, and Germany, may be satisfied with shallow water technology for the near term, because the North Sea has an abundance of shallow water wind sites. To activate the deepwater wind energy resource in the United States, a concerted R&D effort must be commissioned to address the issues specific to this technology, including dynamic modeling of the turbine and floating platform, floating platform optimization, low-cost mooring and anchor development, floating wind turbine COE optimization strategies, deepwater erection and decommissioning, standards governing floating wind turbines, deepwater resource assessment, and other specific deepwater concerns. These relationships are shown in Figure 6.

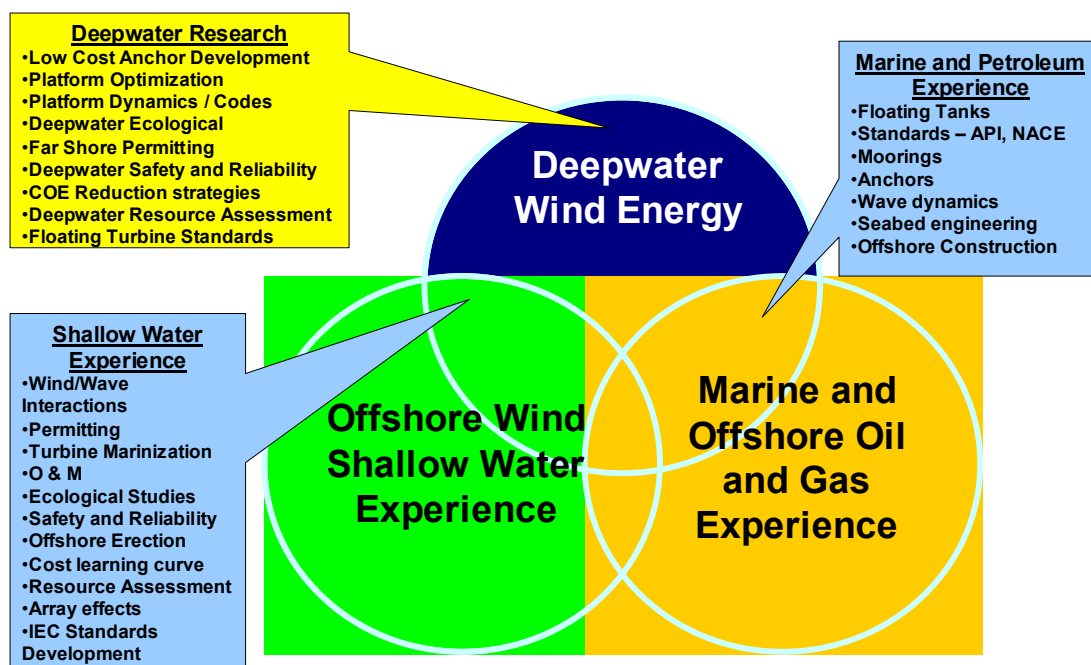

Figure 6 – Deepwater Research and Development Strategy

Summary

Offshore wind energy development is an unexplored U.S. domestic power resource that is estimated to be economically developable using megawatt-scale wind turbines in large offshore wind farms within a decade. Taking into account significant exclusions for shipping lanes, environmental easements, and viewshed concerns, areas off the coast of the United States, within a 50-nm limit, contain resources of almost 907 GW; an amount greater than current installed U.S. electrical capacity. When additional resources in the Gulf Coast and Great Lakes regions are determined, this number will grow. Much of the offshore wind resource lies close to major urban load centers with high-energy costs, and can be brought to market with minimal new transmission construction.

With 98 GW of this resource located in waters shallower than 30 m, a near-term market is available for the industry to gain experience and mature the technology. This analysis shows that deepwater offshore wind development is practical with a proactive R&D agenda involving close collaborations between the oil and gas industry, and the offshore wind community. Demonstrations that prove the viability and cost effectiveness of this new technology for large-scale offshore applications will be critical to securing financing and insurance in the earlier stages. As the first projects are deployed over the next few years, the permitting process will become better defined and more streamlined to ensure that offshore wind projects are deployed with care and consideration to all ocean stakeholders without adding undue risk.

New wind technology can be developed that could make floating wind turbines economical, at energy costs as low as \$0.051/kWh in Class 6 winds by 2015, given sufficient volume production. Though current technologies can be deployed today in shallow water, improvements in wind turbine design and installation methods are essential to minimize the COE and make offshore wind electricity competitive with conventional generation technology.

Acknowledgments

The authors would like to recognize Alan Laxson, Marc Schwartz, Donna Heimiller, Bob Thresher, Bonnie Ram, and Brian Smith for their contributions to the content of this paper. In addition, the U.S. Department of Energy is recognized for its support of this project.

References

1. Web site for the European Wind Energy Association accessed May 19, 2004.
<http://www.ewea.org/>
2. Snodin, H., "SeaWind Europe," Greenpeace, March 2004. www.greenpeace.org, ISBN 1 903907 08 x.
3. Web site for Offshore Wind Energy, accessed May 19, 2004.
<http://www.offshorewindenergy.org/>
4. Web site for AWS Truewind, Accessed May 19, 2004.
<http://www.awstruwind.com/inner/windmaps/windmaps.htm>
5. Malcolm, D.J., Hansen, A.J., "WindPACT Turbine Rotor Design Study," National Renewable Energy Laboratory, NREL/SR-500-32495, August 2002.

6. Shafer, D.A., et al., "WindPACT Turbine Design Scaling Studies: Technical Area 4 – Balance-of-Station Cost," National Renewable Energy Laboratory, NREL/SR-500-29950, July 2001.
7. Smith, K., "WindPACT Turbine Design Scaling Studies Technical Area 2: Turbine, Rotor, and Blade Logistics," National Renewable Energy Laboratory, NREL/SR-500-29439, June 2001.
8. Poore, R.Z., Lettenmaier, T., "Alternative Design Study Report: WindPACT Advanced Wind Turbine Drive Train Designs Study," National Renewable Energy Laboratory, August 2003.
9. Musial W.D, Butterfield, C. P., and Boone, A., "Feasibility of Floating Platforms Systems for Wind Turbines," NREL/CP-500-34874, November 2003.
10. Studie naar haalbaarheid van en randvoorwaarden voor drijvende offshore windturbines. ECN, MARIN, Lagerwey the Windmaster, TNO, TUD, MSC, Dec. 2002.
11. "Opti-OWECS" (5 Volumes), Institute for Wind Energy, Delft University, August 1998.
12. Jamieson, P., Workshop Presentation "Upscaling Issues for Large Turbines & Experience with Design of Floating Offshore Turbines," Workshop on Deep Water Offshore Wind Energy Systems, Washington DC, October 15-16, 2003.
13. Henderson, A.R., Leutz, R., and Fujii, T., "Potential for Floating Offshore Wind Energy in Japanese Waters," *Proceedings of The Twelfth (2002) International Offshore and Polar Engineering Conference*, Kitakyushu, Japan, May 26–31, 2002, ISBN: 1-880653-58-3; ISSN: 1098-6189.
14. Milborrow, D., "Offshore Wind Rises to the Challenge," *Windpower Monthly*, April 2003.
15. Millborrow, D., "Size Matters – Getting Cheaper," *Windpower Monthly*, January, 2003.
16. De Vries, E., "Multi-Megawatt Turbines Taking Hold," *WindStats Newsletter*, Autumn 2002.
17. Milborrow, D., "No Size Constraints in Sight for Wind Turbines," *WindStats Newsletter*, Autumn 2002.
18. Milborrow, D. "Will Downward Trends in Wind Prices Continue?" *WindStats Newsletter*, Summer 2002.
19. "Offshore Wind Energy: Ready to Power a Sustainable Europe, Concerted Action on Offshore Wind Energy in Europe," NNE5-1999-562, Final Report, Supported by the European Commission, December 2001.
20. Rademakers, L.W.M.M., et al. "Assessment and Optimisation of Operation and Maintenance of Offshore Wind Turbines", *Proceedings of the European Wind Energy Conference*, Madrid, Spain, June 2003.
21. Electrotek Concepts, Poseidon Engineering, "Preliminary Design Study of Electrical Collection System for Ocean Current Energy System," Unpublished Report, National Renewable Energy Laboratory, April 2002.

REPORT DOCUMENTATION PAGE

Form Approved
OMB No. 0704-0188

The public reporting burden for this collection of information is estimated to average 1 hour per response, including the time for reviewing instructions, searching existing data sources, gathering and maintaining the data needed, and completing and reviewing the collection of information. Send comments regarding this burden estimate or any other aspect of this collection of information, including suggestions for reducing the burden, to Department of Defense, Executive Services and Communications Directorate (0704-0188). Respondents should be aware that notwithstanding any other provision of law, no person shall be subject to any penalty for failing to comply with a collection of information if it does not display a currently valid OMB control number.

PLEASE DO NOT RETURN YOUR FORM TO THE ABOVE ORGANIZATION.

1. REPORT DATE (DD-MM-YYYY) June 2004			2. REPORT TYPE Conference Paper			3. DATES COVERED (From - To)		
4. TITLE AND SUBTITLE Future for Offshore Wind Energy in the United States: Preprint					5a. CONTRACT NUMBER DE-AC36-99-GO10337			
					5b. GRANT NUMBER			
					5c. PROGRAM ELEMENT NUMBER			
6. AUTHOR(S) W. Musial and S. Butterfield					5d. PROJECT NUMBER NREL/CP-500-36313			
					5e. TASK NUMBER WER4 3512			
					5f. WORK UNIT NUMBER			
7. PERFORMING ORGANIZATION NAME(S) AND ADDRESS(ES) National Renewable Energy Laboratory 1617 Cole Blvd. Golden, CO 80401-3393					8. PERFORMING ORGANIZATION REPORT NUMBER NREL/CP-500-36313			
9. SPONSORING/MONITORING AGENCY NAME(S) AND ADDRESS(ES)					10. SPONSOR/MONITOR'S ACRONYM(S) NREL			
					11. SPONSORING/MONITORING AGENCY REPORT NUMBER			
12. DISTRIBUTION AVAILABILITY STATEMENT National Technical Information Service U.S. Department of Commerce 5285 Port Royal Road Springfield, VA 22161								
13. SUPPLEMENTARY NOTES								
14. ABSTRACT (Maximum 200 Words) Until recently, the offshore wind energy potential in the United States was ignored because vast onshore wind resources have the potential to fulfill the electrical energy needs for the entire country. However, the challenge of transmitting the electricity to the large load centers may limit wind grid penetration for land-based turbines. Offshore wind turbines can generate power much closer to higher value coastal load centers. Reduced transmission constraints, steadier and more energetic winds, and recent European success, have made offshore wind energy more attractive for the United States. However, U.S. waters are generally deeper than those on the European coast, and will require new technology. This paper presents an overview of U.S. coastal resources, explores promising deepwater wind technology, and predicts long-term cost-of-energy (COE) trends. COE estimates are based on generic 5-MW wind turbines in a hypothetical 500-MW wind power plant. Technology improvements and volume production are expected to lower costs to meet the U.S. Department of Energy target range of \$0.06/kWh for deployment of deepwater offshore wind turbines by 2015, and \$0.05/kWh by 2012 for shallow water. Offshore wind systems can diversify the U.S. electric energy supply and provide a new market for wind energy that is complementary to onshore development.								
15. SUBJECT TERMS wind energy; wind turbines; offshore wind								
16. SECURITY CLASSIFICATION OF:			17. LIMITATION OF ABSTRACT UL	18. NUMBER OF PAGES	19a. NAME OF RESPONSIBLE PERSON			
a. REPORT Unclassified	b. ABSTRACT Unclassified	c. THIS PAGE Unclassified			19b. TELEPHONE NUMBER (Include area code)			